

Gas evolution and pressure increase during undesirable chemical reactions.

A survey of the experimental methods to detect gas evolution and pressure increase

Bernhard Hentschel ^{a,*}, Volker Schliephake ^b

^a Hüls Aktiengesellschaft, FEZ/Verfahrenstechnik, Marl, 45764, Germany

^b BASF Aktiengesellschaft, ZET/ES, Ludwigshafen, 67056, Germany

(Received 22 June 1992; accepted 29 January 1993)

Abstract

The methods of measurement presented enable gas evolution and pressure build-up to be ascertained in constant volume or constant pressure mode. Conversion of these results to match other pressures, however, is only possible given very precise knowledge of gas solubility and the real behaviour of the gas concerned. Consequently, it is advisable to carry out measurements under the conditions actually presupposed by the question at issue.

1. OUR INTENTION

Before considering how pressure can be determined during chemical reactions, we should first clarify why pressure and gas evolution should be investigated during chemical reactions. There are four main reasons for doing this: for the proper and safe construction of chemical process plants; to prevent accidents; to evaluate the reaction mechanism of a reaction; and to optimize process plants.

Investigations into pressure and gas evolution affect the safety and economic viability of a process. There is a golden rule

A safe process is also an economic process.

It is well known what disastrous consequences may ensue from chemical reactions if they encounter unintended or uncontrollable conditions. The reason for any destruction of a process plant is rarely the thermal event entailed by these incidents but the pressure event combined with it. It is possible for a variety of chemical reactions to build up pressure. This may

* Corresponding author.

be intended in some cases, but pressure constituting a source of damage arises either if the rate of pressure increase is very high or if high final pressures exceeding the limits of the plant are reached. The aim of this paper is to present some tools for detecting cases in which these limits are possibly exceeded.

In an open apparatus, violent pressures can only arise in the context of explosions or detonations, because the entire opening in the apparatus works as a vent area. But in closed apparatus or in those with small orifices, pressure exceeding the stability limits of the apparatus may be produced.

2. DIFFERENT TYPES OF PRESSURE BUILD-UPS DURING CHEMICAL REACTIONS, CLASSIFIED ACCORDING TO SOURCE

When assessing chemical reactions, three different types of pressure rise have to be distinguished, the criterion for this being their source. These three types are:

1. The pressure build-up occurs within a desired chemical reaction. This concerns all kinds of reactions involving a desired gas evolution. A typical reaction of this kind is the decomposition of a diazonium salt or the decarboxylation of malonic acid esters.

2. The pressure build-up arises within an undesired chemical reaction. This especially concerns decomposition reactions. A typical example is the decomposition of organic nitro compounds at elevated temperatures.

3. The pressure is built up solely as a result of vapour pressure. This is a very common situation in closed reactors. Provided that the gas phase and the liquid phase can exist in thermodynamic equilibrium in the reactor, the vapour pressure will depend only on the temperature and the composition of the liquid phase.

In practical applications, all of these kinds of pressure coexist to varying extents. A diagram illustrating this is shown in Fig. 1. In the following section, the experimental devices most widely used for assessing pure

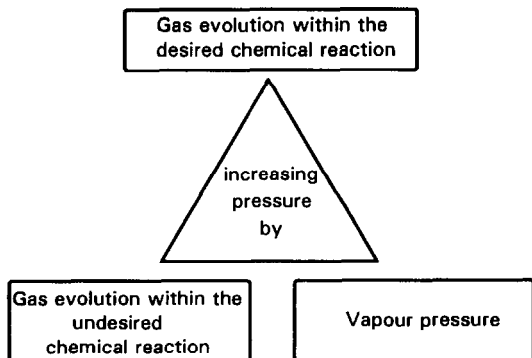

Fig. 1. The different types of pressure build-ups occurring during chemical reactions.

substances and chemical reaction mixtures in terms of their pressure evolution are surveyed. This survey cannot be exhaustive. None of the methods presented is “the best” one, but all of them have their merits under certain conditions.

3. EXPERIMENTAL METHODS

Two different classes of experimental methods are distinguished in this paper: isobaric and isochoric methods. With isobaric methods, the pressure around the sample is kept constant and the measured parameter is the volume of gas emitted by the sample as a function of time or temperature. In isochoric methods, the volume is kept constant and the measured parameter is the pressure within the sample volume. The advantage of the former is the simplicity of maintaining a constant pressure of 1 bar; the advantage of the latter is the simplicity of the experimental devices used.

The selection of the most suitable method has always to be governed by the question as to what information the measurement result is intended to yield, because, as explained below, a result is only valid for the conditions under which it was obtained in the experiment.

3.1. *Methods involving constant pressure (isobaric methods)*

The method that is the basis of all the experimental methods mentioned here is the one that involves direct measurement of a gas flow released during a chemical reaction. The experiments are either carried out in an enclosed space, the pressure being maintained constant by means of some regulatory equipment, or they are carried out under atmospheric pressure as described in ref. 1. With the first method, the gas volume is measured as it escapes from the closed vessel.

3.1.1. *Burette apparatus*

A very simple but efficient apparatus for measuring gas evolution at 1.0 bar is shown in Fig. 2. This apparatus is particularly useful for testing the thermal stability of heat transfer oils.

A tube approx. 50 cm in length, constructed in such a fashion as to enable the condensate running down it to be removed, is attached to the sample vessel which is kept at a precise temperature. Gases are measured in the glass burette, the readings obtained thus indicating the mass of the condensable substances and the volume of the released gases as a function of experimental time.

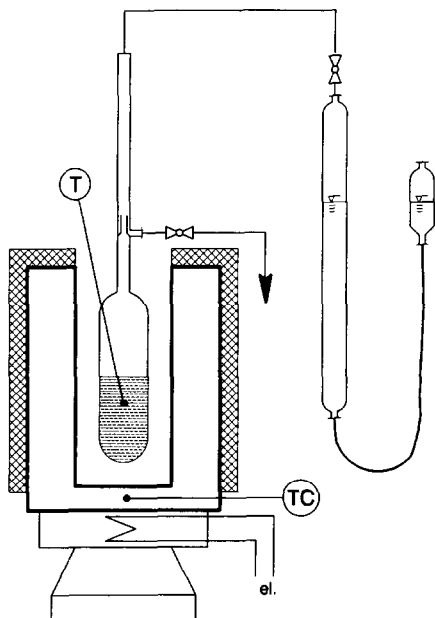

Fig. 2. Burette apparatus. Key: T, temperature indicator; TC, temperature controller; el., electrical heater.

A typical measurement curve obtained using this apparatus, showing the quantity of gas generated as a function of time, is presented in Fig. 3(a). The velocity of gas evolution v can be computed from the slope of the curve. If readings are made at various temperatures, then the activation energy of the decomposition reaction can be ascertained from the gas evolution velocity as a function of temperature, as shown in Fig. 3(b).

The question arises as to whether the results obtained using this ap-

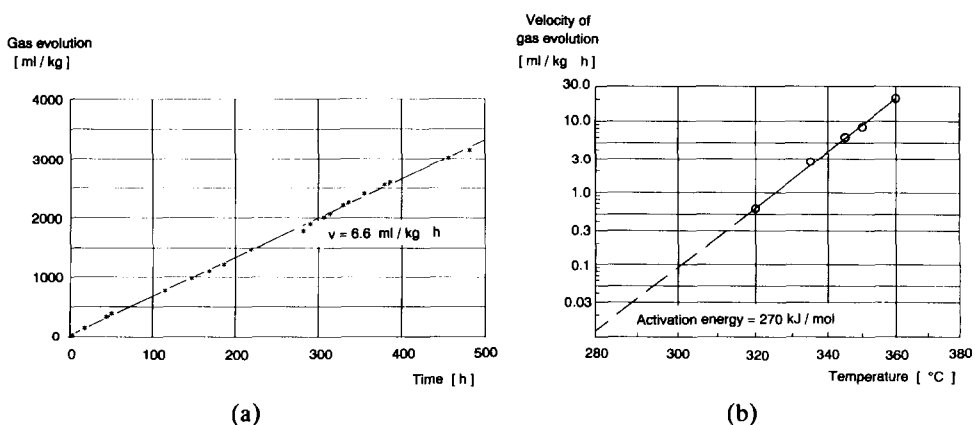

Fig. 3. (a) Gas evolution obtained using the burette apparatus. (b) Gas evolution at various temperatures.

paratus can be converted, for example to determine the pressure increase in a closed vessel that is 80% full.

Two problems present themselves here.

1. The gas. If the gas volume established experimentally is converted to a value for an ideal gas filling the unoccupied gas space in the vessel, an excessively high pressure is certain to be obtained because the gas can dissolve in the product. It would be possible for this problem to be eliminated by applying solubility theories such as UNIFAC, provided the compositions of both the gas and the fluid are known.

2. The condensate. Problems may arise if the composition of the condensate is not the same as that of the sample. Some of the condensate can exist in the form of vapour in the gas phase. For calculations, the molecular weight and the solubility in the liquid phase must be known.

Both these computations require a great deal of effort being put into the chemical analysis and calculation.

The results obtained using this very simple method cannot be converted to other pressures. Results obtained using an isobaric measuring procedure can only describe the behaviour of the substance under the experimental conditions.

3.1.2. *Isobaric, completely closed apparatus*

Another apparatus designed to measure gas evolution under any constant pressure is shown in Fig. 4. The sample is introduced into the apparatus, which has been pre-heated to match the reaction temperature, and poured onto the reactor base, e.g. by rotating the sample holder. To

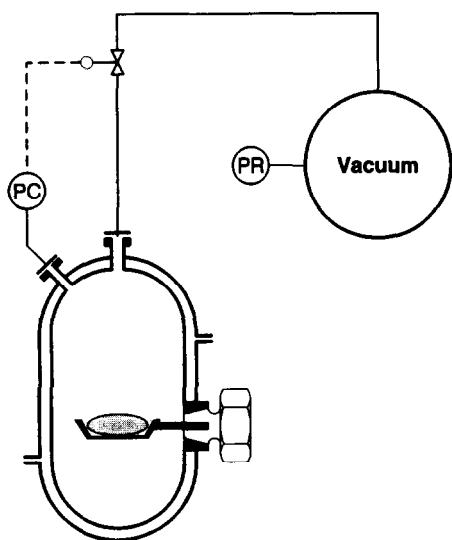

Fig. 4. Isobaric, completely closed apparatus. Key: PC, pressure controller; PR, pressure registration.

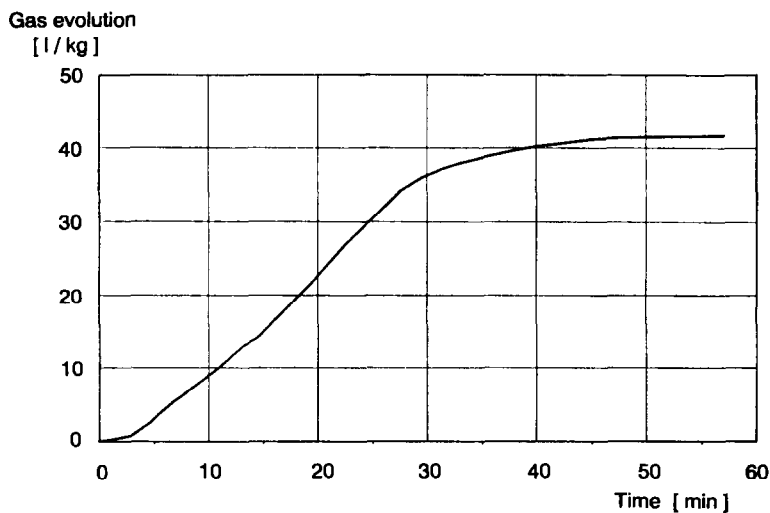

Fig. 5. Gas evolution obtained using the closed apparatus.

enhance heat transfer, the base can be covered with a layer of high-boiling liquid; the sample thus reaches the reaction temperature immediately. The sample must not be soluble in this heat-transfer liquid. The bulb of known volume attached to the apparatus was evacuated prior to the start of the experiment. If a gas is generated, then it is sucked into this bulb by means of a pressure maintenance device, the pressure increase in the bulb being proportional to the quantity of gas evolved.

A typical measurement curve for the amount of gas evolved as a function of time is reproduced in Fig. 5. It can be seen that only slight fluctuations occur, these being caused by the pressure maintenance device.

In the same manner, a reaction calorimeter with pressure regulation may be used, if the gas flowing out of the reactor is measured.

3.1.3. *Thermobalance and the DTG method*

The principle of thermogravimetry is the measurement of a mass or a change in mass as a function of temperature or time. The equipment used is the so-called thermobalance. The temperature is usually increased linearly and the decomposition of the material under investigation is measured. The signal corresponds to the sum of all the volatilizing components: no simple distinction can be made between gases and evaporating liquids. This method is a very good screening test. Thermobalances often have a facility for also measuring the thermal signal from the sample, so that a correlation is given between thermal and mass signals. This method is the most widespread isobaric method [2, 3].

As an example for this method, we present the decomposition of

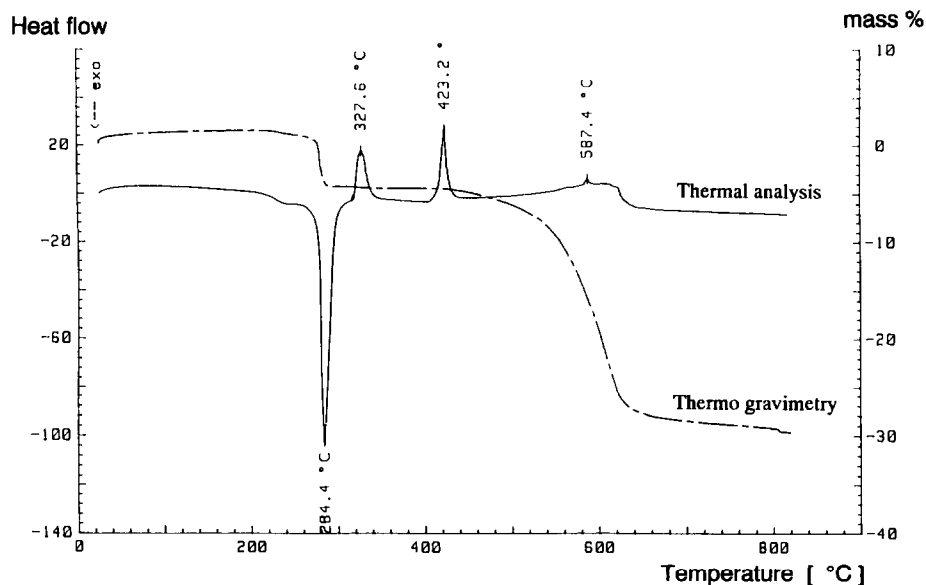

Fig. 6. Thermogravimetry and differential thermoanalysis of $K_2S_2O_8$.

potassium peroxodisulphate. This is shown in Fig. 6 where two different stages of decomposition can be distinguished.

3.2. Methods involving constant volume (isochoric methods)

Measurements involving constant volume imply that the sample is inside a heatable pressure vessel. Pressure evolution as a function of time is the variable under consideration. With these experiments, a distinction has to be made between measurements carried out at a low [4] or at a high [5] fill level in the test reactor, i.e. distinction between a relatively small and a relatively large gas volume.

3.2.1. Pressure vessel apparatus

The most simple device for measurements of this type is shown in Fig. 7. Such a device provides representative results if the question at issue is the pressure inside the reactor. However, it can yield no statement about the amount of gas actually liberated, because there is no information either as to whether the gas will behave as an ideal gas or a real gas, or as to whether it will dissolve in the product.

If the measurement is made at a low fill level, the amount of gas dissolved in the liquid may be neglected and the gas may be calculated on the basis of the ideal gas law. But it is impermissible to extrapolate the pressure at a higher fill level from these results by multiplying the actual pressure reading by the ratio of the gas volumes, because solubility is pressure-dependent

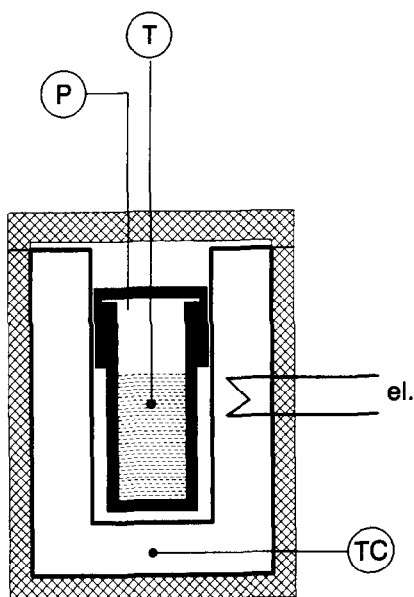

Fig. 7. Pressure vessel apparatus. Key: T, temperature registration; P, pressure registration; TC, temperature controller; el., electrical heater.

and equilibria may be altered if chemical reactions have taken place in the reactor.

As an example, again, the decomposition of 100 g of potassium peroxodisulphate is presented here (Fig. 8). A direct measurement of the gas volumes is impossible because the reaction is too fast, the rate of pressure rise being greater than 10 bar s^{-1} in the 340 ml vessel. But a

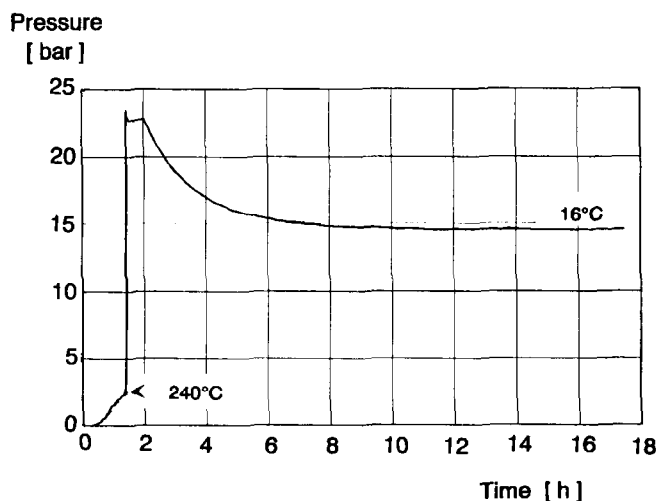

Fig. 8. Decomposition of $\text{K}_2\text{S}_2\text{O}_8$ in the pressure vessel apparatus.

calculation of the quantity of gas evolved, assuming that the ideal gas law holds, shows that half a mole of oxygen is formed per mole of peroxodisulphate.

However, the following problem may arise: rapid exothermic reactions no longer proceed isothermally. The thermal capacity of the sample is small compared to that of the sample receptacle. If the liberated substance is not only a permanent gas but also a volatilizing component, it may condense on the walls of the vessel; the pressure increase will then be smaller than that occurring in an industrial-scale reactor heated up by the reaction.

3.2.2. *VSP apparatus*

This commercially-manufactured apparatus [6] is designed to monitor the temperature and pressure of an exothermic reaction proceeding adiabatically. There are options for working in “constant volume mode” or in “constant pressure mode”; in the latter mode, the gas evolution can be monitored as a volumetric rate of flow by means of an externally attached instrument.

The testing chamber is a sample receptacle with very thin walls, approx. 120 ml in volume, inserted into an electrical heating device. This arrangement is thermally insulated and surrounded by a guard heater. As a result of the extremely small mass of the receptacle, the arrangement is almost adiabatic in terms of the thermal balance, and any temperature increase will correspond to that which would actually occur in an industrial-scale vessel. The phi factor is approx 1.07.

Tests using an electrical heating device have shown that the electrical energy input reappears as an adiabatic temperature increase. The testing chamber together with the heating devices is inserted into a pressure vessel. There are open and closed testing chambers. If a pressure is built up in the closed testing chamber, then it will be automatically compensated for by a pressure of equal magnitude on the enclosing pressure vessel, so that the walls of the sample receptacle will have to absorb practically no forces. An appropriately designed pressure-monitoring device can make adjustments for rates of pressure increase of up to 40 bar s^{-1} . In operation, the VSP uses an automatic heat, wait-search step-scanning mode to determine the onset of the exothermic reaction. On detecting the reaction, the caloric and pressure data are monitored.

3.2.3. *Confined-pressure heat accumulation calorimeter (DWSt)*

This apparatus is a small 200 ml capacity reactor with thin reactor walls and with an option for adding one of the educts at any time. The wall heater is regulated by the internal reactor temperature so as to maintain adiabatic conditions. The pressure inside the oven is kept at the same level as that inside the reactor, so that the reactor walls are not exposed to any pressure difference between the inside and the outside. The temperature and

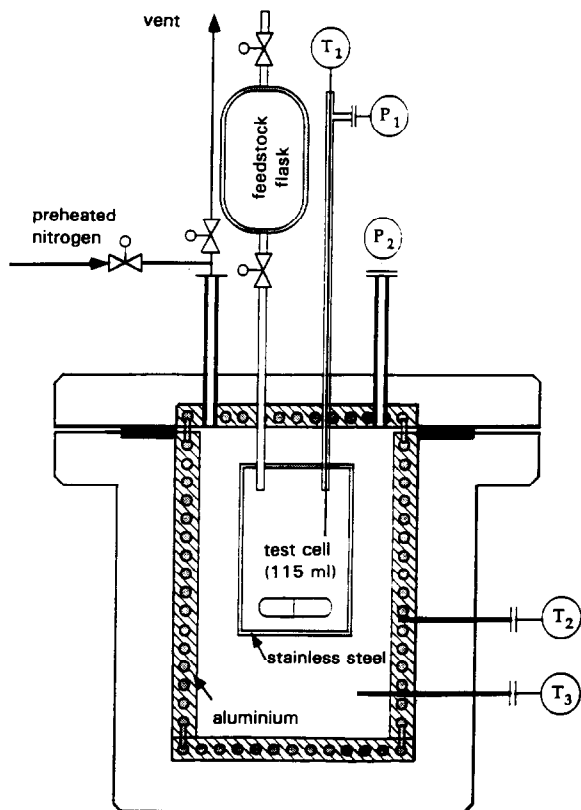

Fig. 9. Confined-pressure heat accumulation calorimeter (DWSt).

pressure curves for this small reactor system show that the system is a very good model for simulating the behaviour of very large industrial-scale reactors, which often behave almost adiabatically. The apparatus is shown in Fig. 9.

If the test reactor is filled in the same way as the real reactor under consideration, this equipment will give the exact pressure curve obtained in the event of an adiabatic runaway.

3.2.4. ARC

In the ARC [7] (accelerating rate calorimeter, a commercially manufactured apparatus), a sample of a few grams is held in a spherical bomb. In operation, the ARC uses an automatic heat, wait-search step-scanning mode to determine the onset of the exothermic reaction. On detecting the reaction, the calorimeter will monitor caloric and pressure data.

The bomb has to withstand the pressure of the gases generated, which is why it has a large mass compared with that of the sample, thus

necessitating considerable corrections during the execution and evaluation of the tests (ϕ factor, 1.3–1.5).

3.2.5. Pressure DTA

If the use of small quantities of reactants is required and if the investigation is not meant to be conducted adiabatically or isoperibolically but under isothermic or dynamic conditions, then the pressure DTA method is the one that appears most suitable. This is the normal DTA method carried out using pressure-proof housings, the internal pressure of which is also recorded as a measurable variable [7]. In the case of this small-volume method, precise determination of the fill percentage presents a difficulty, but it is especially suitable for tests carried out on valuable products and is a most suitable screening method.

3.2.6. Reaction calorimeter

The pressure reactor of a reaction calorimeter can also be used to determine the gas evolved and the pressure evolution over the course of a chemical reaction. The decomposition of a phenyl diazonium salt is presented in Fig. 10. In this example, 800 ml of the diazonium solution, which is stable at 0°C, was stored at this temperature in a 1.8-l reactor belonging to a reaction calorimeter. Then the reactor contents were heated up to 78°C within 100 min. While the temperature increases in a markedly linear fashion, the pressure curve exhibits pronouncedly non-linear behaviour, as expected, because the rate of gas evolution depends on the reaction rate constant of the decomposition process. This reaction rate constant obeys Arrhenius's law of temperature dependence. The final

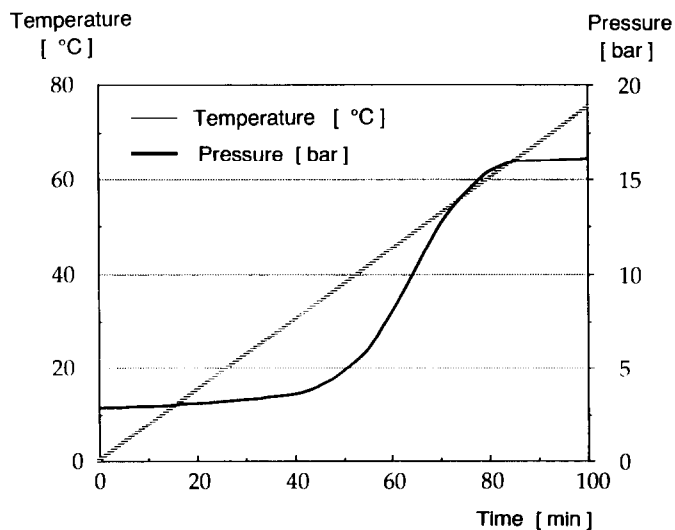

Fig. 10. Decomposition of a diazonium salt in a reaction calorimeter.

pressure, 16 bar in this example, is closely correlated with the degree of fill of the reactor and the total amount of pure diazonium salt in the reactor when the decomposition process is complete.

4. CONCLUSIONS

The methods of measurement presented enable gas evolution and pressure build-up to be ascertained. Conversion of these results to match other pressures, however, is only possible given very precise knowledge of gas solubility and the real behaviour of the gas concerned.

The chemical mechanism of decomposition reactions is hardly ever known. What is known is that, as a result of the pressure built up by the decomposition gases, the course of these reactions is different to those of reactions running at normal pressure. Reactions running at elevated pressure are usually accelerated.

Consequently, it is advisable to carry out measurements under the conditions actually presupposed by the question at issue.

REFERENCES

- 1 Directive 84/449/EG, Official Journal of the European Communities, L251, 27 A.12, 1984.
- 2 H.G. Wiedemann and G. Bayer, Trends and applications of thermogravimetry, in Fortschritte der chemischen Forschung 77, Springer, Berlin, 1978, p. 68.
- 3 W. Hemminger and H. Cammenga, Methoden der therm. Analyse, Springer, Berlin, 1989, p. 57.
- 4 T.M. Groothuisen, Jh.W. Hartgerink and H.J. Pasman, 1st Int. Loss Prevention Symposium, Elsevier, Amsterdam, London, New York, 1974 p. 239.
- 5 O. Klais and T. Grewer, 4th Int. Loss Prevention Symposium, Inst. Chem. Eng. Symp. Ser., 82 (1983) C24.
- 6 H.K. Fauske, Hazards from Pressure, Inst. Chem. Eng. Symp. Ser., 102 (1987) 133.
- 7 D.I. Townsend, Thermochim. Acta, 37 (1980) 1.