

Development of a new thermogravimetric system for performing constant rate thermal analysis (CRTA) under controlled atmosphere at pressures ranging from vacuum to 1 bar

M.D. Alcalá, J.M. Criado *, F.J. Gotor, A. Ortega, L.A. Perez Maqueda and C. Real

Departamento de Química Inorgánica e Instituto de Ciencias de Materiales de Sevilla, Centro Mixto C.S.I.C. — Universidad de Sevilla, Apdo. 1.115, 41080 Sevilla, Spain

(Received 30 July 1993; accepted 5 January 1994)

Abstract

A CI electronic microbalance which allowed sample weights up to 5 g to be measured with a maximum sensitivity of 1 μg has been used to develop a new constant rate thermal analysis (CRTA) technique. This permitted a constant rate of change of weight $|C| \geq 10 \mu\text{g min}^{-1}$. Moreover, it has been extended to constant rate jump thermal analysis (CRJTA). The microbalance is attached to a conventional system of vacuum and gas storage that allowed work to be carried out under vacuum or under controlled atmosphere.

The performance of the equipment was checked by studying both the thermal decomposition of CaCO_3 and the recombination reaction of silicon and nitrogen, producing Si_3N_4 .

INTRODUCTION

The ICTAC council has recently approved [1] the term “Controlled Rate Thermal Analysis” (CRTA) for those techniques which monitor the temperature versus time profile needed to maintain a chosen, fixed rate of change of a property of a sample in a specified atmosphere. This method was first developed by Rouquerol [2] and Paulik and Paulik [3] who applied it to controlled rate thermogravimetry. Rouquerol used a high-vacuum microbalance and the temperature was monitored by controlling the pressure increase associated with the gases generated during the thermal decomposition of a solid. Paulik and Paulik’s [4] quasi-isothermal technique used the derivative unit of a microbalance for controlling the reaction rate. This microbalance was designed to work under a pressure of 1 atmosphere of the gases generated in the reaction. After the pioneering work of Rouquerol and Paulik and Paulik, a series of techniques applying CRTA in different experimental arrangements were described [5–8].

* Corresponding author.

It has been pointed out that CRTA methods have a higher resolution than conventional methods for discriminating overlapping processes. This explains why different CRTA techniques have been introduced by manufacturers of dilatometers and electrobalances [9–13] and are now available on the market. However, these techniques operate under flowing gases, not under a vacuum.

The scope of the present work is to develop a new controlled-rate thermogravimetric system which works either under vacuum or under controlled atmosphere and, maintains a large sensitivity even when using a large amount of sample (up to 5 g). This feature is required when using the equipment to synthesize materials. It has been reported that CRTA produces solids with homogeneous structures and low particle sizes [14–16].

EXPERIMENTAL

A CI electronic microbalance which allowed sample weights up to 5 g with a maximum sensitivity of 1 μg , was used for developing the new CRTA technique. The balance was attached to the support frame of a vertical furnace (1500°C) provided with a raising/lowering mechanism. The balance was connected to both a conventional vacuum system which reduced the pressure to 10^{-2} mbar and a system of flowing gases up to a total pressure of 1 atmosphere. The partial pressure of a reactive gas can be selected by mixing it with an inert gas using coupled flowmeters. The hanging wire supporting the crucible was centered inside an 8 mm inner diameter ceramic tube. This minimized the buoyancy effects working under flowing gases as shown in Fig. 1.

The controlled unit of the balance was equipped with a microprocessor which stored 29 continuously updated weights collected over 37.4 s. The time derivative system provided with the equipment uses a least-squares method to fit the best line through the succession of weights stored in the microprocessor.

The set of points of weight change ΔW stored as a function of the time t are fitted to the straight line

$$\Delta W = A + Bt \quad (1)$$

in such a way that the sum of the squares Q of the distances of the points from the straight line is a minimum. The distance is measured in the vertical direction

$$Q = \sum_{j=1}^n (\Delta W_j - A - Bt_j)^2 \quad (2)$$

For Q to be a minimum

$$\frac{dQ}{dA} = -2 \sum (\Delta W_j - A - Bt_j) = 0 \quad (3a)$$

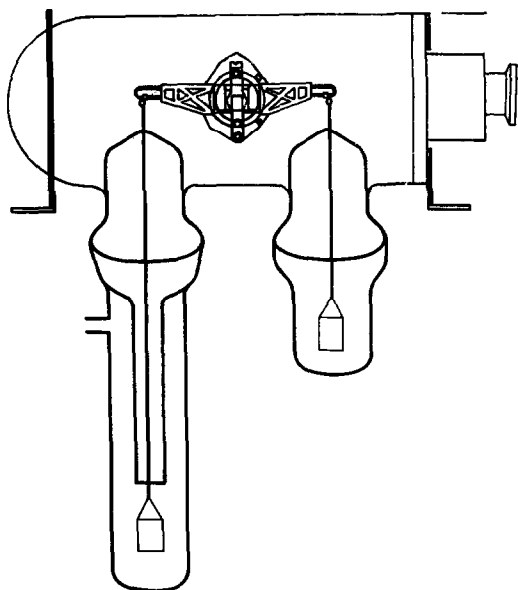

Fig. 1. A detail of the head of the CI microbalance.

$$\frac{dQ}{dB} = -2 \sum t_j (\Delta W_j - A - B t_j) = 0 \quad (3b)$$

and this can be rearranged to

$$AN + B \sum t_j = \sum \Delta W_j \quad (4a)$$

$$A \sum t_j + B \sum t_j^2 = \sum t_j \Delta W_j \quad (4b)$$

If the t_j values are taken symmetrically about zero then $\sum t_j = 0$ and

$$B = \frac{dW}{dt} = \frac{\sum t_j \Delta W_j}{\sum t_j^2} \quad (5)$$

The reaction rate B is converted into an analogue output through a D/A converter. The sensitivity can be selected in such a way that a full scale of 10 mV corresponded with a reaction rate ranging from 0.1 to 80 mg min⁻¹. The analogue output was interfaced to a PID controller, a Coreci model Microcor III, which monitored the temperature of the furnace in such a way that the rate of weight change was maintained constant at a value $|C| \geq 10 \mu\text{g min}^{-1}$, arbitrarily selected. An inverse or direct proportional band can be selected from the controller keyboard allowing a choice of C values, positive or negative depending on whether the reaction being controlled involves either a weight increase, e.g. solid–gas recombination reactions, or a decrease, e.g. solid decomposition reactions, respectively. Moreover, a device was developed which introduced an external electrical signal into the controller that allowed the reaction rate to be changed between two preset

values. These can alternatively be maintained constant during pre-selected periods of time in a cyclical way by means of an asynchronous temporizer. This device allowed constant jump rate thermal analysis (CRJTA).

RESULTS

The performance of the equipment described above was checked, firstly by studying the thermal decomposition kinetics of CaCO_3 under a vacuum of 2×10^{-3} mbar using both CRTA and CRJTA and, secondly, by studying the nitridation of silicon powders under flowing nitrogen at a total pressure of 1 atmosphere according to the reaction



Figure 2 shows the CRTA curve obtained for the thermal decomposition of CaCO_3 at a pressure of 2×10^{-3} mbar and a constant decomposition rate of $C = 3 \times 10^{-3} \text{ min}^{-1}$. The convex shape of this curve is characteristic of an n th order reaction as shown in a previous reference [17] and, therefore, it can be fitted by the equation

$$\frac{d\alpha}{dt} = A \exp(-E/RT)(1-\alpha)^n \quad (7)$$

where α is the reacted fraction at time t , A is the pre-exponential Arrhenius factor, E is the activation energy and n the reaction order.

If the experiment is carried out at a constant reaction rate, $C = d\alpha/dt$, eqn. (7) becomes, after rearranging in logarithmic form

$$\frac{1}{\ln(1-\alpha)} = \frac{1}{n} \ln \frac{A}{C} - \frac{E}{nRT} \quad (8)$$

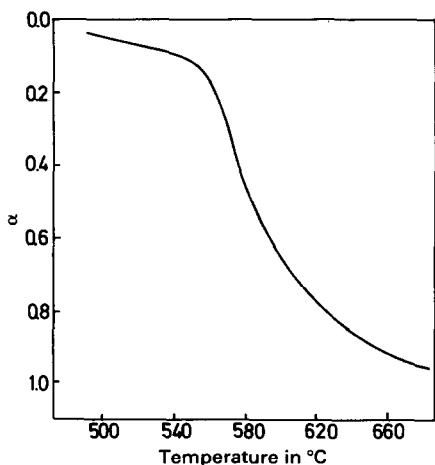

Fig. 2. CRTA curve obtained for the thermal decomposition of CaCO_3 at a vacuum of 2×10^{-3} mbar and a constant reaction rate C of $3.1 \times 10^{-3} \text{ min}^{-1}$.

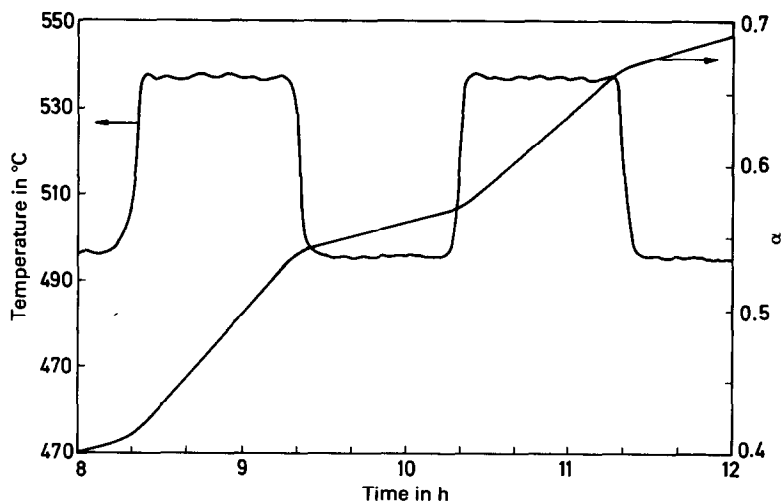

Fig. 3. A detail of the jump CRTA experiment carried out under a vacuum of 2×10^{-3} mbar for determining the activation energy of the thermal decomposition of CaCO_3 .

The plot of the left-hand side of eqn. (8) against the reciprocal of the temperature leads to a straight line whose slope gives the value of E/n . It is not possible to discriminate simultaneously E and n from a single CRTA curve.

The analysis of the data of Fig. 2 according to eqn. (8) gives a value of $E/n = 60 \pm 3 \text{ kcal mol}^{-1}$. The n value can be accurately determined if the activation energy is known. The activation energy of the thermal decomposition of CaCO_3 has been determined by means of the constant jump rate thermal analysis (CRJTA). Figure 3 shows, as an example, two of the above 20 cycles recorded in the CRJTA experiment carried out using a sample weight of 120 mg and a pressure of 2×10^{-3} mbar. The two states of the sample to be compared have almost the same reacted fraction. Thus, the activation energy can be calculated without previous knowledge of the actual reaction mechanism [18] according to the equation

$$\ln \frac{C_1}{C_2} = -\frac{E}{R} \left[\frac{1}{T_1} - \frac{1}{T_2} \right] \quad (9)$$

where C_1 and C_2 are the two rates in the cycle corresponding to the temperatures T_1 and T_2 , respectively.

The analysis of the CRJTA data by means of eqn. (9) indicates that the activation energy is independent of α in the range $0.1 \leq \alpha \leq 0.9$ giving a mean value of $E = 41 \pm 3 \text{ kcal mol}^{-1}$. The value previously reported for E/n was $60 \pm 3 \text{ kcal mol}^{-1}$; thus a reaction order n of 0.68 ± 0.1 is obtained. Therefore, it can be concluded that the reaction of the thermal decomposition of CaCO_3 follows an R_3 kinetic model. These results are in good

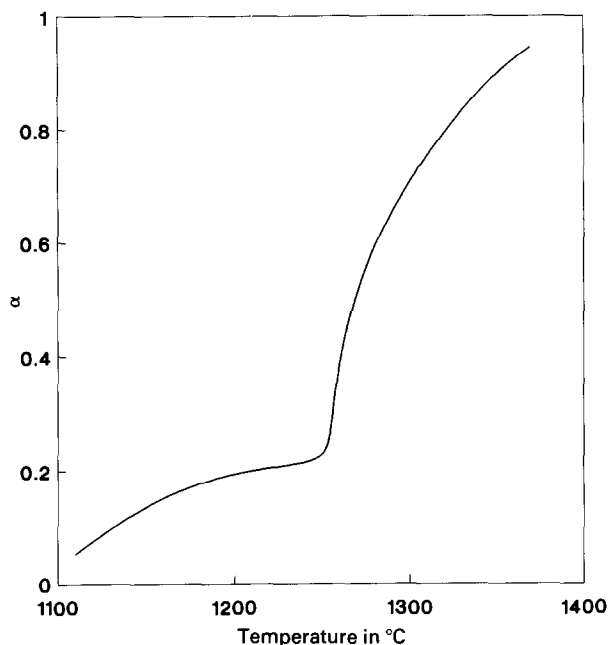

Fig. 4. CRTA curve of the nitridation of silica under a nitrogen flow of $170 \text{ cm}^3 \text{ min}^{-1}$ at a total pressure of 1 atm and a constant reaction rate C of $3.71 \times 10^{-4} \text{ min}^{-1}$.

agreement with those obtained from a detailed kinetic analysis carried out in a previous paper [18] using the same CaCO_3 sample (D'Hemio a.r.).

However, it was considered of interest to check the applicability of the experimental system developed here for recording CRTA curves of reactions that proceed with an increase in weight. Figure 4 shows the CRTA curve obtained for the nitridation of pure silicon (supplied by Aldrich) at a constant rate C of $3.71 \times 10^{-4} \text{ min}^{-1}$ using a starting weight of silicon of 300 mg. These results indicate that the reaction takes place in two steps. The first probably corresponds [19] to the devitrification of the layer of natural silica covering the silicon surface, followed by the reaction with the metal according to the scheme



The second step mainly corresponds to the direct nitridation of silicon.

ACKNOWLEDGEMENT

The financial support by DGICYT of the project PB90-130 is acknowledged.

REFERENCES

- 1 J.O. Hill, *For Better Thermal Analysis and Calorimetry*, ICTA, Victoria, Australia, 1991.
- 2 J. Rouquerol, *J. Therm. Anal.*, 2 (1970) 123.
- 3 J. Paulik and F. Paulik, *Anal. Chim. Acta*, 56 (1971) 328.
- 4 F. Paulik and J. Paulik, *Thermochim. Acta*, 100 (1986) 23.
- 5 M.H. Stacey, *Anal. Proc.*, 22 (1985) 43.
- 6 M. Reading and J. Rouquerol, *Thermochim. Acta*, 85 (1985) 299.
- 7 J. Arellano, J.M. Criado and C. Real, *Thermochim. Acta*, 135 (1988) 219.
- 8 C. Real, M.D. Alcalá and J.M. Criado, *J. Therm. Anal.*, 38 (1992) 797.
- 9 M. Uptmor, *The TA Hotline*, TA Instruments, New Castle (USA), 1991, Vol. 2, p. 1–3.
- 10 F. Leclerc, *J. Therm. Anal.*, 38 (1992) 515.
- 11 S. Winkler, P. Davies and J. Janoschek, *J. Therm. Anal.*, 40 (1993) 999.
- 12 P. Davies, W.D. Emmerich and S. Knoppe, *J. Therm. Anal.*, 40 (1993) 1205.
- 13 Instruction manuals of the following microbalances: Setaram, model TGA 92; Netzsch, model STA 409; TA Instruments, model Hi-Res TGA 2950.
- 14 J. Rouquerol and M. Gantaume, *J. Therm. Anal.*, 11 (1977) 201.
- 15 J.L. García-Fierro, S. Mendioroz and J. Sainz, *J. Colloid Interface Sci.*, 93 (1983) 487.
- 16 J.M. Criado, F.J. Gotor, C. Real, F. Jimenez, S. Ramos and J. del Cerro, *Ferroelectrics*, 115 (1991) 43.
- 17 J.M. Criado, A. Ortega and F. Gotor, *Thermochim. Acta*, 157 (1990) 171.
- 18 F. Rouquerol and J. Rouquerol, in G.H. Wiedeman (Ed.), *Thermal Analysis*, Vol. 1, Verlag, Bassel and Stuttgart, 1972, p. 473.
- 19 M. Barsoum, P. Kangutkar and M.J. Koczac, *J. Am. Ceram. Soc.*, 74 (1991) 1248.