



ELSEVIER

Thermochimica Acta 264 (1995) 173–183

thermochimica
acta

Development of the simultaneous thermal analysis/X-ray scattering measurement system

Hirohisa Yoshida ^{a,*}, Ryoichi Kinoshita ^b, Yoshihiko Teramoto ^b

^a *Department of Industrial Chemistry, Tokyo Metropolitan University, Hachioji, Tokyo 192-03, Japan*

^b *Scientific Instruments Division, Seiko Instruments Ltd., Oyamacho, Shizuoka 410-13, Japan*

Received 10 October 1994; accepted 3 February 1995

Abstract

A new simultaneous DSC/X-ray measurement system was developed for the purpose of combining X-ray scattering data and calorimetric data. The DSC/X-ray measurement system was equipped with a conventional wide-angle X-ray diffractometer (WAXD). The phase transition behavior of pure hexatriacontane was measured by the DSC/WAXD, both on heating and cooling. The accuracy and reproducibility of the simultaneous DSC/X-ray instrument were comparable with the conventional DSC.

Keywords: DSC; Thermal analysis; Wide angle X-ray diffractometer; X-ray scattering

1. Introduction

Differential thermal analysis (DTA) and differential scanning calorimetry (DSC) are well-established methods with which to determine the phase transitions of materials. In particular, DSC is widely used in both scientific and industrial fields because of the conventional instrument's ability to observe phase transition behaviors. DSC data can be used to describe the bulk thermodynamic properties of a system. However, it is not a suitable technique for characterizing thermodynamic phenomena on a molecular level. Furthermore, a careful and exact analysis of DSC data is required to understand what occurs during a phase transition, since DSC measurement essentially uses the dynamic method. When we compare DSC results with data obtained by other techniques suggesting micro-structural change, such as the wide-angle X-ray diffrac-

* Corresponding author.

tion (WAXD) method and spectroscopic methods, we notice that these data may not be comparable with the DSC data concerning the time scale of the measurement and the thermal history of the sample. In order to remove these problems, it is proposed that the DSC method be combined with light transmittance, microscopic observation and WAXD.

Recently, several attempts at simultaneous DSC/X-ray measurement utilizing synchrotron radiation have been reported [1–7]. In most cases, the conventional Mettler hot-stage DSC system was modified for the simultaneous DSC/X-ray measurement [1–4]. We have designed an exclusive simultaneous DTA and X-ray measurement system [8]. This simultaneous system is also aimed at combining calorimetry and spectroscopic measurements such as FT-IR and FT-Raman. We have applied the simultaneous DTA/small-angle X-ray scattering (SAXS) technique utilizing synchrotron radiation in order to analyze the phase transition behaviors of polymeric materials [9, 10] and *n*-alkanes [11], and to perform a conformational analysis of xanthan gum [12] and gellan gum [13]. Although the simultaneous DTA/SAXS instrument showed highly accurate temperature control and operational capability, the DTA signal sensitivity was not sufficient to obtain quantitative thermodynamic information. In this study, we developed an exclusive simultaneous DSC/X-ray instrument which could be integrated to both a synchrotron radiation source and a conventional rotating-anode-type X-ray instrument, and provides a high level of DSC sensitivity.

2. Instrument

A diagram of the simultaneous DSC/X-ray instrument's sample cell is shown in Fig. 1. The basic structure of this instrument is almost the same as the conventional DSC, a Seiko DSC 200. Fig. 2 shows a detailed inside view of the sample cell. One sample holder and one reference holder (inside diameter, 7.4 mm; outside diameter, 7.8 mm; thickness, 0.2 mm; diameter of the hole for the X-ray beam, 3.0 mm) made of platinum are located symmetrically within the cell, opposite to each other with the center being the heat sink. The heat sink, made of silver, (outside diameter, 40 mm; inside diameter, 20 mm) is surrounded by a furnace. Heat flux from the sample and reference are each detected by four pairs of thermocouples (SUS sheathed thermocouple type E with an outside diameter of 1.0 mm). The sample temperature is detected by a type K SUS sheathed thermocouple (1.0 mm diameter). The furnace temperature is detected by another type K thermocouple located inside the furnace. Cooling measurements are carried out by flowing vaporized nitrogen gas into the cooling unit connected with the outside of the furnace. The sample holder in the DSC cell has a 2-mm-diameter hole for transmission of the X-ray beam. The collimated X-ray, with a diameter of less than 1 mm, passes through this hole in order to eliminate parasitic scattering. Each sample and reference holder (8 mm in diameter) are connected with the bottom of the heat sink through four pairs of thermocouples. Therefore, the heat flux always flows through the thermocouples. The sample and reference holders are separated from the outside of the heat sink by a 2-mm-thick lid made of silver in order to minimize heat scattering and to prevent atmosphere convection. The sample cell, including the furnace and cooling

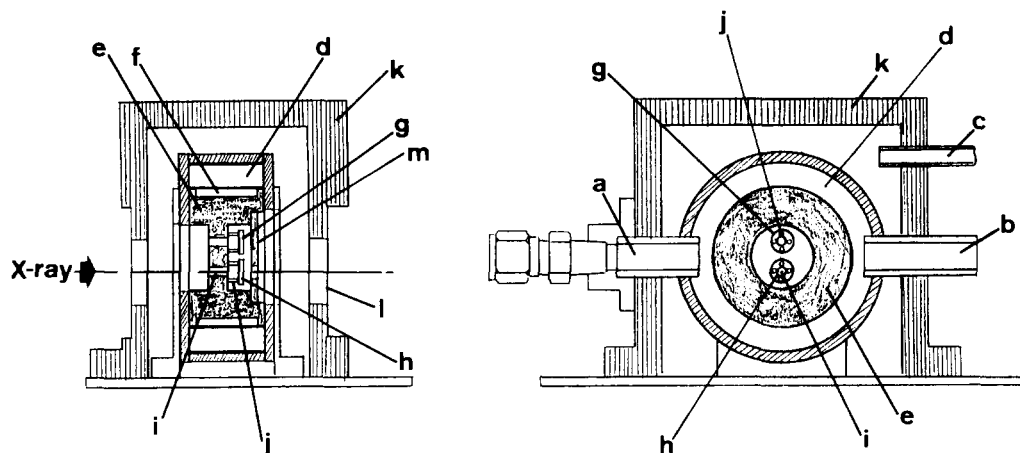

Fig. 1. Sample cell configuration of the simultaneous DSC/X-ray diffraction instrument: a, cooling gas inlet; b, cooling gas outlet; c, gas inlet; d, cooling unit; e, heat sink; f, furnace; g, reference holder; h, sample holder; i, hole for X-ray beam transmission; j, thermocouple; k, bakelite vessel; l, window for X-ray beam transmission; m, silver lid.

unit, is placed in a bakelite vessel making the atmosphere around the sample cell controllable.

3. Experimental

3.1. Sample

Hexatriacontane ($C_{36}H_{74}$) supplied by the Tokyo Kasei Co. Ltd. was used throughout the experiment without further purification. The purity of the $C_{36}H_{74}$ was above 99.8%. The sample as-received was solution-crystallized. Preliminary X-ray work suggested that the solution-crystallized $C_{36}H_{74}$ was monoclinic *M011* with 4.32 nm (001) spacing at 296 K, and that the sample slow-cooled from the melt was orthorhombic with a 4.92 nm (001) spacing at 296 K.

Samples ranging between 1 and 8 mg were clamped in aluminum sample vessels prepared for the simultaneous DSC/X-ray instrument as shown in Fig. 2. The aluminum sample vessel comes in two parts: a pan (outside diameter, 7.2 mm; inside diameter, 7.0 mm; height, 2.4 mm and thickness, 0.1 mm) and a lid (diameter, 7.0 mm; thickness, 0.1 mm). Both the pan and lid have a 3.0-mm-diameter hole at the center. Hexatriacontane, which was held between two sheets of 10- μ m-thick aluminum film of 6.8 mm diameter, was put in a pan and clamped with a lid. Two types of ring spacers (outside diameter, 7.0 mm; inside diameter, 5.0 mm; thickness, 1.0 mm) made of silver and Teflon were used for the liquid sample.

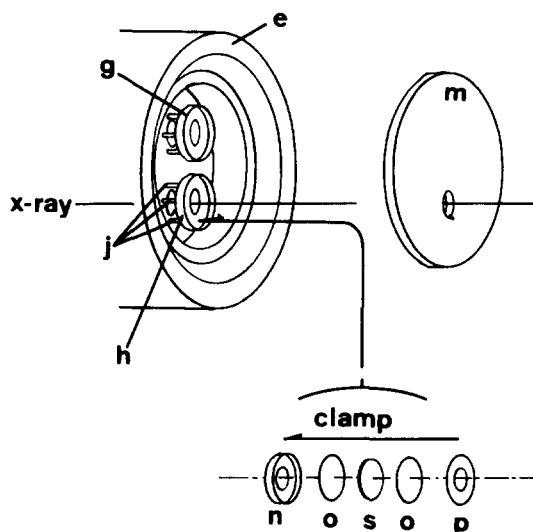

Fig. 2. Inside view of sample cell and sample vessel: e, heat sink; g, reference holder; h, sample holder; j, thermocouple; m, silver lid; n, sample pan; o, 10 μm aluminum film; p, sample pan lid; s, sample.

3.2. X-ray instrument

Measurements were carried out by setting the simultaneous DSC/X-ray instrument on the goniometer of WAXD optics of the Mac Science model SRA MXP-18 X-ray instrument operating at 40 kV and 400 mA. The monochromated and pinhole-collimated X-ray radiation used had a wavelength of 0.15405 nm. A WAXD profile of $\text{C}_{36}\text{H}_{74}$ was obtained in the transmission mode using a scintillation counter in conjunction with a pulse height analyzer at 0.004° of sampling time and a radial diffractometer scanned in the 2θ range from 19.5° to 23.5° at 12°min^{-1} . One WAXD profile of $\text{C}_{36}\text{H}_{74}$ required 0.4 min to measure and save in the work station (SUN Spark1).

3.3. DSC scanning

Temperature and enthalpy were calibrated using standard grade indium, tin and pure water. DSC measurements for $\text{C}_{36}\text{H}_{74}$ were carried out in the temperature range 337–351 K at 0.5 K min^{-1} with heating and cooling under nitrogen gas flow. The sampling time was 0.1 s. One WAXD profile was obtained in a 0.2 K interval.

In order to compare the sensitivity and reproducibility of the simultaneous DSC/X-ray instrument, the conventional type Seiko DSC 200 was used under the same measurement conditions.

4. Results and discussion

The reproducibility of the DSC results for the simultaneous DSC/X-ray instrument evaluated by cycle measurement of indium in the temperature range 423–435 K at 0.5 K min⁻¹ is listed in Table 1. T_{mi} and T_{ci} were determined from the intersection of the two extrapolation lines from the base line and the slope of the transition peak. The reproducibilities of the temperatures and enthalpies of transition are comparable with conventional DSC, both on heating and cooling.

Two heating DSC curves of solution-crystallized C₃₆H₇₄ (about 1.8 mg) measured by the simultaneous DSC/X-ray instrument and by conventional DSC are shown in Fig. 3. The solution-crystallized material shows three endothermic transitions at 344.9, 345.6 and 347.8 K. The temperatures and enthalpies of each transition observed by both the DSC/X-ray instrument and conventional DSC 200 showed good agreement. In a comparison of the height of the transition peak observed by both instruments under the same conditions, the simultaneous DSC/WAXD instrument peak height was about 1.15 times higher than that observed by the conventional DSC 200. The noise level of the simultaneous DSC/WAXD was about 3 times larger than the conventional DSC. However, this noise level was low enough to allow analysis of phase transitions in the DSC/X-ray measurements.

Two DSC heating curves of C₃₆H₇₄ (2.138 mg and 4.578 mg) are shown in Fig. 4 (solution-crystallized) and Fig. 5 (slow cooling from the melt). The reproducibilities of the transition temperatures observed for samples of different mass were, at most, 0.4 K for the melting peak temperature of the solution-crystallized material and within 0.1 K for the slow-cooled material. Because the solution-crystallized material possessed a thin lamella-type morphology, establishing good contact with sample vessel was very difficult. The large difference which appeared with the solution-crystallized material was a result of sample packing, and these tendencies were usually observed by conventional DSC as well. Reproducibility of the transition enthalpy for each transition observed for four different runs of the solution-crystallized material and ten different runs of the slow-cooled material was, at most, 5%. This value is also comparable with the conventional DSC.

Table 1
Reproducibility of DSC results^a of indium

Run number	T_{mi}/K	T_{mp}/K	T_{ci}/K	T_{cp}/K	$\Delta H_m/(Jg^{-1})$
1 heating	430.2	430.5			28.9
2 cooling			429.1	428.9	28.5
3 heating	430.4	431.0			28.5
4 cooling			429.3	429.2	28.5
5 heating	430.5	431.1			28.3
6 cooling			429.4	429.2	28.4

^a Obtained using the simultaneous DSC/WAXD apparatus with sample weight 5.2865 mg at scanning rate 0.5 K min⁻¹.

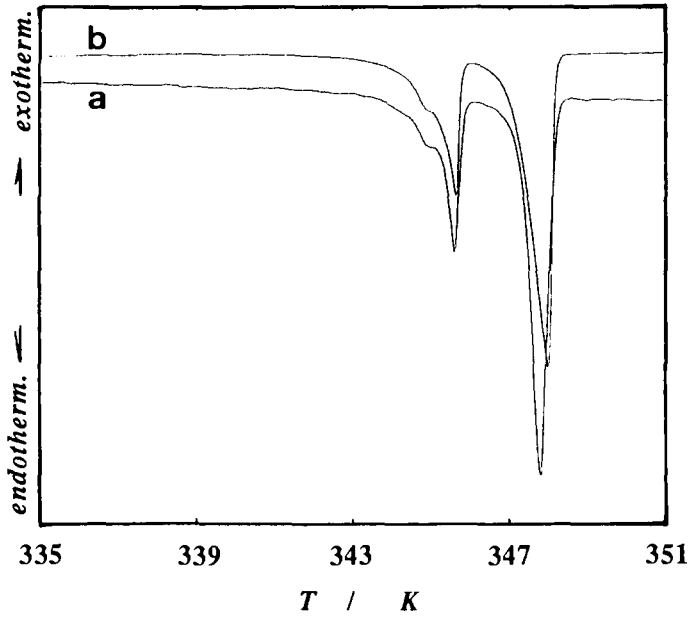

Fig. 3. DSC heating curves of solution-grown crystals of $C_{36}H_{74}$ observed by (a) simultaneous DSC/WAXD and (b) conventional DSC with sample weights (a) 1.803 mg and (b) 1.821 mg at 0.5 K min^{-1} .

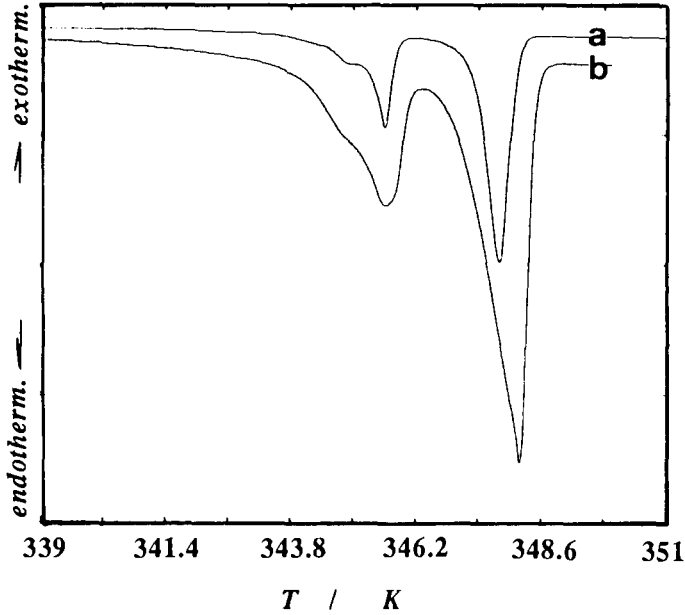

Fig. 4. DSC heating curves of solution-grown crystals of $C_{36}H_{74}$ with different sample weights: (a) 2.138 mg and (b) 4.578 mg, observed by simultaneous DSC/WAXD at 0.5 K min^{-1} .

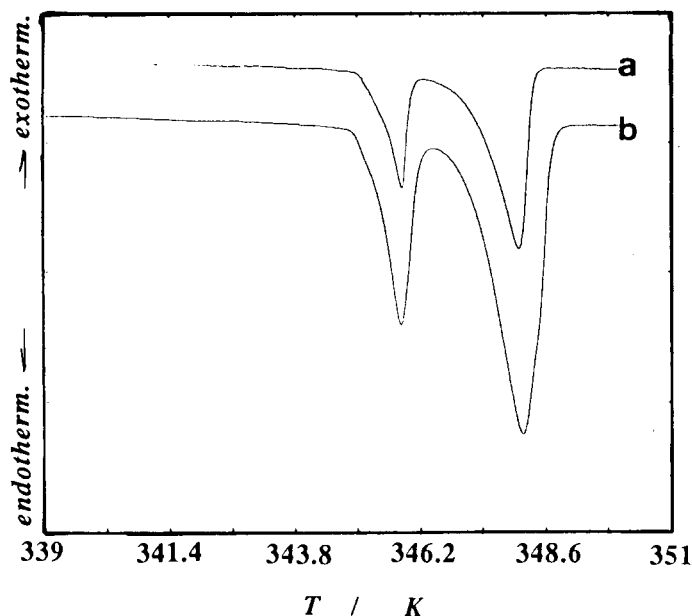

Fig. 5. DSC heating curves of slow-cooled crystals of $C_{36}H_{74}$ with different sample weights (a) 2.138 mg and (b) 4.578 mg, observed by simultaneous DSC/WAXD at 0.5 K min^{-1} .

The simultaneous DSC and WAXD results obtained from heating the solution-crystallized material, cooling from the melt, and heating the slow-cooled material are shown in Fig. 6, Fig. 7 and Fig. 8, respectively. The sample weight was 4.578 mg and the scanning rate 0.5 K min^{-1} . The solution-grown crystal was in the monoclinic form (M phase) at room temperature, and the M phase transformed to the modified monoclinic phase by tilting of the end methyl group (C phase) at 345 K [14]. WAXD profiles 3 and 4 in Fig. 6 suggest that the transition from the M phase to the C phase occurred at 345 K. With increasing temperature, the C phase transformed to the hexagonal phase (H phase) at 345.5 K and the H phase melted at 348 K [14]. WAXD profiles 5 and 6 in Fig. 6 indicate that the transition from the C phase to the H phase was completed at the peak temperature. WAXD peaks disappeared (WAXD profile 17) at 348 K which corresponds to the melting peak temperature.

On cooling from the melt, WAXD peaks were detected at 347.5 K which was the starting temperature of the exothermic peak on the higher temperature side. Within the temperature range of the exothermic peak, the intensities of the WAXD peaks increased without any observed peak shift. WAXD profiles 4–13 in Fig. 7 suggest that the crystallization of H phase occurred at the exothermic peak on the higher temperature side. Upon cooling, the H phase transformed to another phase at 344.9 K which was the starting temperature of an exothermic peak on the lower temperature side. The new phase observed at temperatures below 344.9 K contained C phase, as suggested by WAXD profile 15 in Fig. 7. The DSC cooling curve indicates that there are at least two

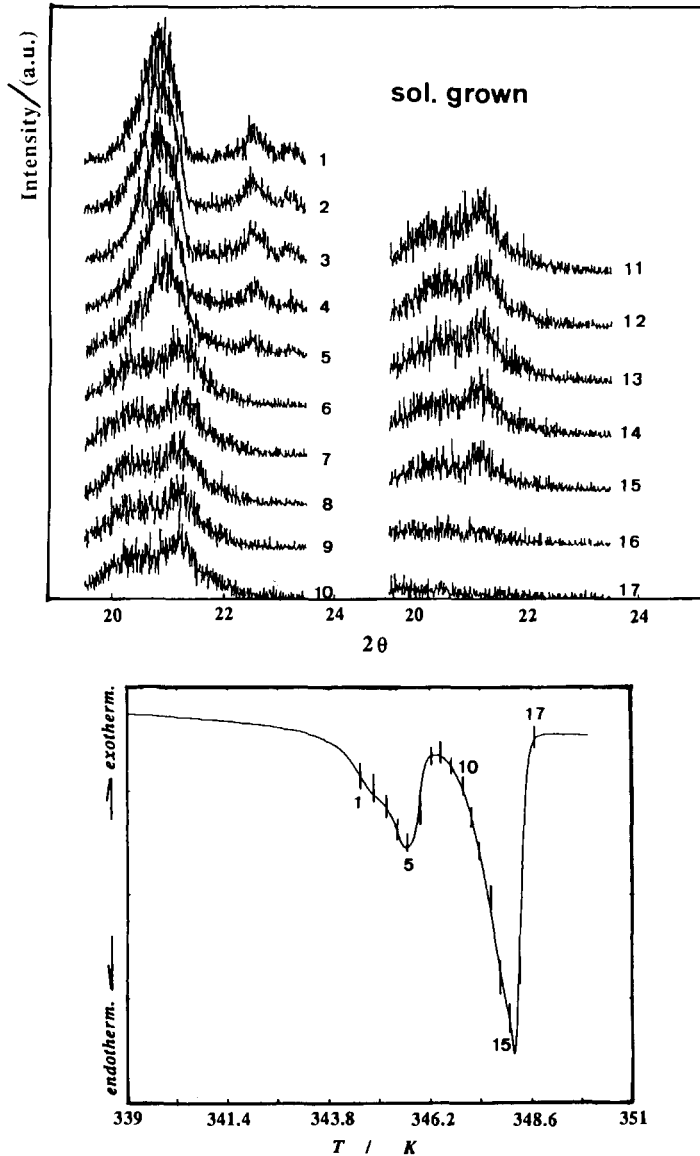

Fig. 6. Simultaneous DSC and WAXD results observed on heating of solution-grown $C_{36}H_{74}$ (4.578 mg) observed by simultaneous DSC/WAXD at 0.5 K min^{-1} . Numbers shown in X-ray profiles correspond to those in DSC. Temperatures: 1, 344.6 K; 5, 345.7 K; 10, 347 K; 15, 348.1 K; and 17, 348.7 K.

exothermic peaks with peak temperatures at 344.4 and 344.6 K within the exothermic peak at the lower temperature. The WAXD profile of slow-cooled material at room temperature suggests that this material contained both the M phase and the C phase, and a part of the C phase transformed to the M phase during the transition at 344.4 K.

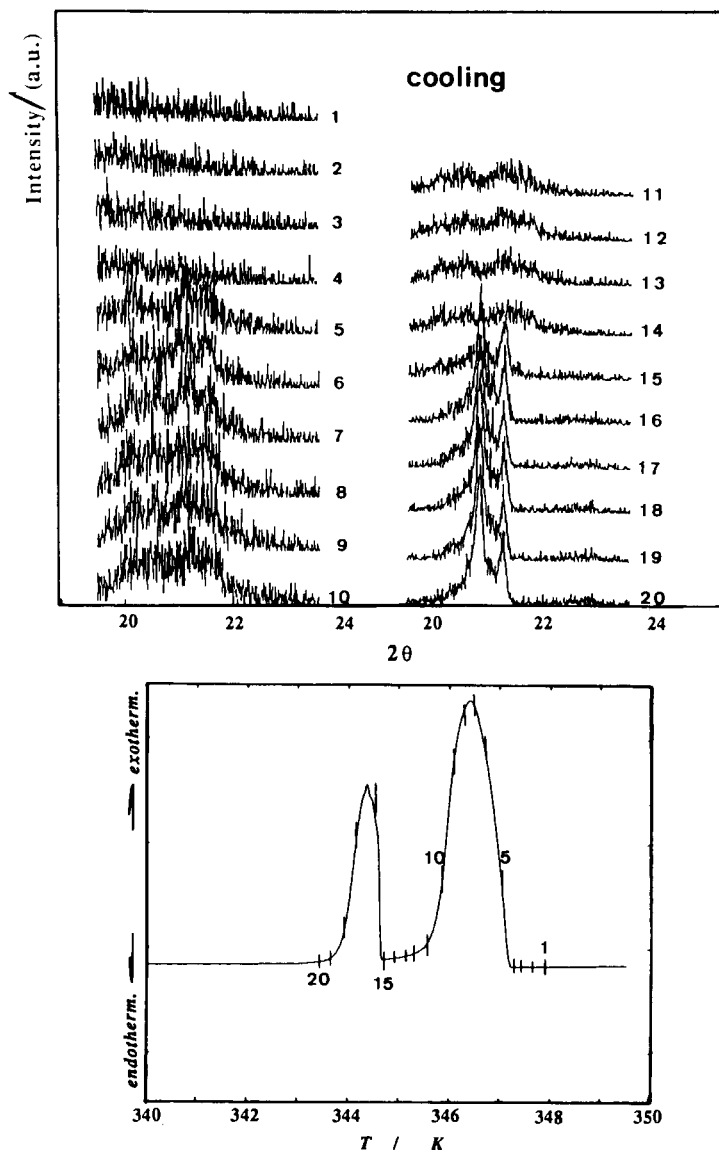

Fig. 7. Simultaneous DSC and WAXD results observed on cooling of $C_{36}H_{74}$ (4.578 mg) from the melt observed by simultaneous DSC/WAXD at 0.5 K min^{-1} . Numbers shown in X-ray profiles correspond to those in DSC. Temperatures: 1, 347.9 K; 5, 347 K; 10, 345.8 K; 15, 344.7 K; and 20, 343.4 K.

The DSC heating curve of the slow-crystallized material shown in Fig. 8 differs from that of the solution-crystallized material shown in Fig. 6. The transition from the M phase to the C phase is not clear in the DSC curve of the slow-crystallized material. However, the differential DSC (D-DSC) curve of the slow-crystallized sample indicated

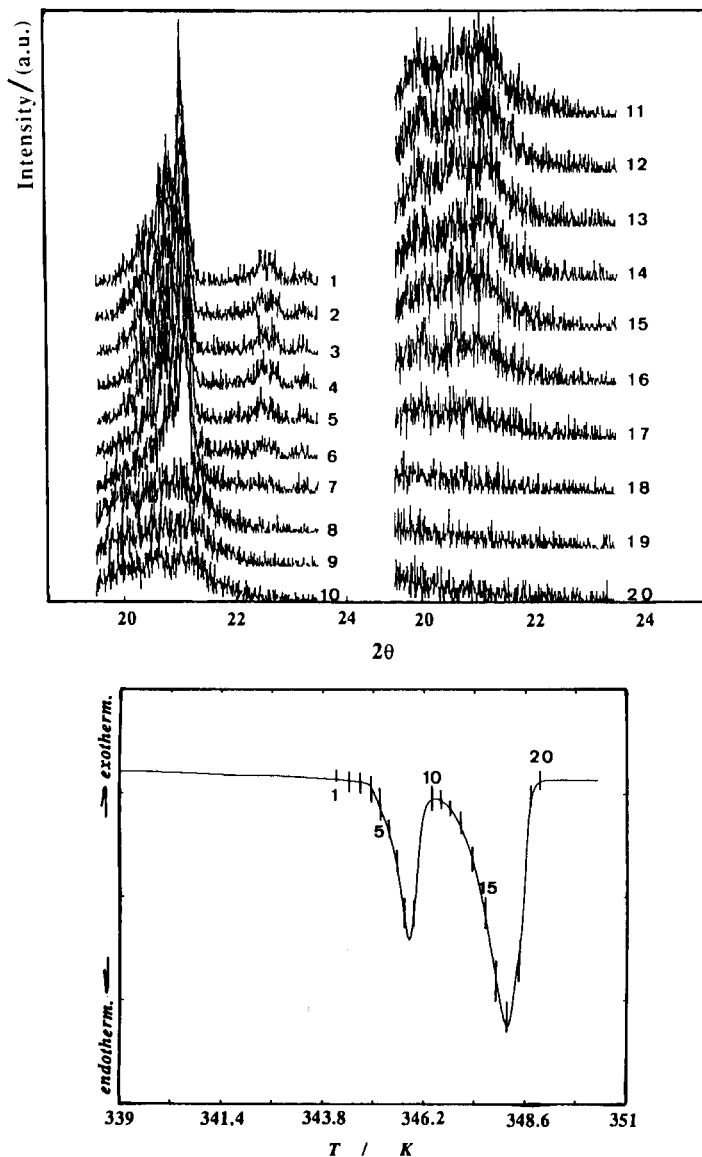

Fig. 8. Simultaneous DSC and WAXD results observed on heating of slow cooled $C_{36}H_{74}$ (4.578 mg) observed by simultaneous DSC/WAXD at 0.5 K min^{-1} . Numbers shown in X-ray profiles correspond to those in DSC. Temperatures: 1, 344.1 K; 5, 345.2 K; 10, 346.4 K; 15, 347.6 K; and 20, 348.9 K.

that the endothermic peak observed at around 345 K was composed of two endothermic peaks. Although the endothermic peaks observed at the lower temperature for the solution-crystallized and the slow-cooled materials were different, the transition enthalpy was almost the same. Upon heating, the WAXD profiles 6, 7 and 8 shown in

Fig. 8 suggest that the transitions from the M phase to the C phase and from the C phase to the H phase are present in the lower temperature endothermic peak.

The new simultaneous DSC/WAXD instrument developed in this work has a high accuracy and high reproducibility of temperature and enthalpy, which are comparable with the conventional DSC. This instrument can be integrated to a conventional anode-type X-ray diffraction instrument with a scintillation counter because of the high DSC sensitivity. In this study, a WAXD profile was taken every 20 s. Under these conditions, the phase transition dynamics of polymers showing polymorphism have been analyzed using this simultaneous DSC/WAXD apparatus [15]. If we use a strong X-radiation source such as synchrotron radiation and a high-sensitivity X-ray detector such as a position-sensitive proportional counter and/or an imaging plate, one WAXD profile may be collected each second. Under such conditions, a time-resolved X-ray measurement can be carried out using faster heating rates [16]. In addition to the simultaneous measurements, this instrument can be integrated with an FT-IR and/or FT-Raman instrument. Results of this research will be published in the near future [17].

References

- [1] G. Ungar and J.L. Feijoo, *Mol. Cryst. Liq. Cryst.*, 180B (1990) 281.
- [2] G. Ungar, J.L. Feijoo, A. Keller, R. Yourd and V. Percec, *Macromolecules*, 23 (1990) 3411.
- [3] M. Kellens, W. Meeussen, R. Gehrke and H. Reynaers, *Chem. Phys. Lipids*, 58 (1991) 131.
- [4] H. Chung and M. Caffrey, *Biophys. J.*, 63 (1992) 438.
- [5] A.J. Ryan, *J. Therm. Anal.*, 40 (1993) 887.
- [6] J. Wang, M. Caffrey, M.J. Bedzyk and T.L. Penner, *J. Phys. Chem.*, 98 (1994) 10957.
- [7] H. Yoshida, M. Takahashi, F.X. Quinn, T. Hatakeyama and H. Hatakeyama, *Photon Factory Activity Reports*, 10 (1992) 272.
- [8] H. Yoshida, R. Kinoshita and Y. Teramoto, 28th Japanese Conference on Calorimetry and Thermal Analysis, Tokyo, 1992, Abstracts, p. 26.
- [9] M. Takahashi and H. Yoshida, *Rep. Prog. Polym. Phys. Jpn.*, 35 (1993) 213.
- [10] T. Toda, H. Yoshida and K. Fukunishi, *Polymer*, 36 (1995) 699.
- [11] H. Yoshida, M. Takahashi, T. Hatakeyama, H. Hatakeyama, M. Urabe and K. Takamizawa, 29th Japanese Conference on Calorimetry and Thermal Analysis, Nagaoka, 1993, Abstracts, p. 258.
- [12] H. Yoshida, M. Takahashi, T. Hatakeyama and H. Hatakeyama, *Photon Factory Activity Reports*, 10 (1992) 271.
- [13] H. Yoshida and M. Takahashi, *Food Hydrocolloid*, 7 (1993) 387.
- [14] W. Piesczek, G.R. Strobl and K. Malzahn, *Acta Crystallogr. Sect. B*, 30 (1974) 1278.
- [15] H. Yoshida, *Thermochim. Acta*, (1995) in press.
- [16] H. Yoshida and M. Takahashi, *Photon Factory Activity Reports*, 12 (1994), in press.
- [17] H. Yoshida, Y. Ichimura, R. Kinoshita and Y. Teramoto, *Rep. Prog. Polym. Phys. Jpn.*, 38 (1995) in press.