

Calorimetry goes afield

Ingolf Lamprecht^{a,*}, Erik Schmolz^b

^aInstitut für Biologie, Tierphysiologie, Freie Universität Berlin, Ehrenbergstraße 26–28, D-14195 Berlin, Germany

^bInstitut für Biologie, Zoologie, Freie Universität Berlin, Königin-Luise-Straße 1–3, D-14195 Berlin, Germany

Received 14 September 1999; accepted 26 September 1999

Abstract

It is shown in this speculative paper that modern biological calorimetry need not to be laboratory bound but may go afield in cases where biological systems are fixed in their place (e.g. plants), have strong interactions with their environment or fall victim of artefacts when they are isolated from their natural connections for longer periods (e.g. insect colonies). On the other hand, often it is interesting to perform broad screening tests directly in situ. This survey presents chip calorimeters developed recently for the latter purpose and very simple camping box instruments for large or locally bound systems. Applications for different biological problems are discussed. © 2000 Elsevier Science B.V. All rights reserved.

Keywords: Afield application; Calorimetry; Integrated circuits; Low price calorimeters; Simple construction

1. Introduction

*If the mountain will not come to Mahomet,
Mahomet will go to the mountain.*

Three trends can be observed in calorimetry of the last decades. The first deals with steadily decreasing active volumes down to less than one microliter and corresponding increase in time resolution, due to new developments of specialized microchips [1]. The second concerns a further sophistication of commercial instruments with a multitude of possible reaction vessels, adapted to different applications [2]. The third trend conquers a field which was nicknamed *mega-calorimetry*, i.e. thermal investigations of biological or chemical processes in reaction tanks of many thousand litres [3].

The present paper shall follow a fourth trend: to show that nowadays calorimetry can be used for a manifold of different biological problems, in the laboratory as well as in the field. Heat flux sensors in the form of Peltier elements are offered in any electronic shop for reasonable prices so that it is easy and cheap to construct a calorimeter just for a special purpose. It is the personal experience of the authors that the technical difficulties of calorimeter design are smaller than supposed. Moreover, many (macro)biological processes produce heat flows in the order of several watts. Therefore, no special care has to be taken for extreme temperature stability during the experiment as in usual calorimetry.

Calorimetry in all its facets is usually laboratory bound, due to the type of research being performed, the necessary additional equipment and in the first line due to the demand for a stable thermal environment. Although modern differential or twin set-up instruments are able to compensate smaller changes in the

* Corresponding author. Tel.: +49-30-838-2393;

fax: +49-30-838-2393.

E-mail address: biophys@zedat.fu-berlin.de (I. Lamprecht)

ambient temperature, longer lasting deviations or circadian fluctuations lead to baseline shifts which are hard to evaluate in the subsequent data processing. First calorimeters of the Calvet type had large masses of heat sinks to overcome such problems but were extremely heavy (around 250 kg) and thus not movable. ‘Microcalorimeter’ were milliliter instruments and not at all ‘micro’ concerning their own or their sample sizes.

With the progress of electronics sensitivities of calorimeters increased steadily and sample sizes became smaller at the same time so that one approached truly *micro-* or even, recently, *nanocalorimeters* [1]. Their time constants are so short compared with traditional instruments that full information about reactions is obtained within seconds and no special thermostating devices or heat sinks of large masses are necessary. This makes such calorimeters small, light and easy to transport. One field of interest touched below goes in this direction. On the other hand, there are larger and complex biological systems like single flowers or whole plants as well as nests of social insects with energy outputs of a few Watts. This heat output is so large that even very simple calorimeter devices like Peltier-element driven camping boxes are suited for reliable energetic investigations. This has been shown mainly with social insects like honeybees, bumblebees or hornets and will be discussed in more detail below.

The approaches mentioned are *direct* calorimetry while *indirect* calorimetric measurements are also possible in this area. *Indirect* encounters monitoring gaseous metabolism of oxygen consumption and carbon dioxide production or temperature determinations [4,5]. Transformation to usual energy data can be done by application of oxycaloric coefficients or special cooling laws to the raw data. Such data will be included also in this experimental as well as speculative paper on calorimetry under non-laboratory conditions.

Progress in modern calorimetry aims at increasing sensitivity and long-time stability as well as at more sophisticated calorimetric vessels and equipment to run additional investigations in parallel [2]. Nevertheless, there are still interesting biological tasks where these features play a minor role due to expected large heat outputs. Under such conditions simple calorimeters can be constructed for a few hundred

dollars or even much less in a short time. They are bound to one special problem and are of course not as variable as commercial instruments.

The authors believe that there are by far more interesting questions in biology which can be solved by a creative calorimetry. Further applications and some ideas for useful constructions will be discussed in this paper. *Afield* in the title does not only mean investigations in complete wilderness without any electric connection but also all experiments not bound to a laboratory with thermostatisation and special equipment. Suitable applications are for immobile biological organisms or systems which cannot be transposed to the laboratory or investigated only in parts due to their large size without introducing severe artefacts. Places *afield* may be perhaps a compost hipe, a non-transportable plant or nests of birds, small mammals or insects somewhere in a garden with external electricity. Or an ant hill near a forester’s house, a protected observation area for environmental and climatic investigations, an apiary [6] or even a pond in a botanical garden [7]. Registration of thermal signals must not be performed by usual chart recorders, but modern data loggers with internal batteries are ideal registration means if one has to be completely independent of external energy supply. There are by far too many of them on the market to give any recommendation here.

2. The various calorimeters

2.1. The poor man’s calorimeter (PMC)

Camping boxes used in connection with the battery of a car are equipped with Peltier units at their bottom which keep the content—depending on the direction of electric current flow—cool or warm. As Peltier units are at the same time thermopile heat flux sensors (Seebeck effect), such boxes can be used as simple and cheap calorimeters which we called *Poor man’s calorimeters* (PMC) [8]. They are commercially available with active volumes between 5 and 30 l and heat flux sensitivities of 10–30 mV/W. Such sensitivities are in the same range as that of usual commercial instruments while the weak baseline stability—due to a lack of thermal insulation—is their main drawback, but a differential set-up of two boxes together with an



Fig. 1. Camping box calorimeter (PMC) prepared for long term investigations of a bumblebee colony. For better insulation and baseline stability the PMC is placed in a styrofoam box. It is connected to the outside by a longer entrance duct so that the insects have free access to the environment and can forage as usually. One bumblebee passes the right bend of the duct. Two thermocouples for temperature measurements in the box and in the bumblebee nest are visible inside the box.

additional insulation around the boxes is realizable as in common calorimeters so that the shortcoming is not that severe.

Besides one early investigation on the resting metabolism of Japanese quails [9] PMCs were used in our group mainly for social insects. Experiments started with small springtime bumblebee nests which were transferred from their natural location into a PMC connected with the outdoor surrounding by a tubular entrance duct as shown in Fig. 1 [10,11]. Bumblebees had free access to the outside to continue their usual life and to increase their population during the season. While the heat production rate of the nest varied between 0.3 and 1.4 W, the nest temperature was kept at values between 27 and 32°C. Further investigations with differential PMCs made with two units (Fig. 2) were dedicated to hornet colonies and their nest activities (up to 12.5 W) and to honeybee winter clusters at near freezing point temperatures. Maximum heat output was observed at 0°C with 20.5 W [6].

As with the Japanese quails [9] PMCs can also be applied as simple and easily understandable instruments in practical courses for zoology students or in nutritional physiological investigations when more

sophisticated calorimeters of larger active volume are not available and respirometry shall be supplemented by direct heat measurements. Smaller terrestrial animals such as lizards, snakes or tortoises,

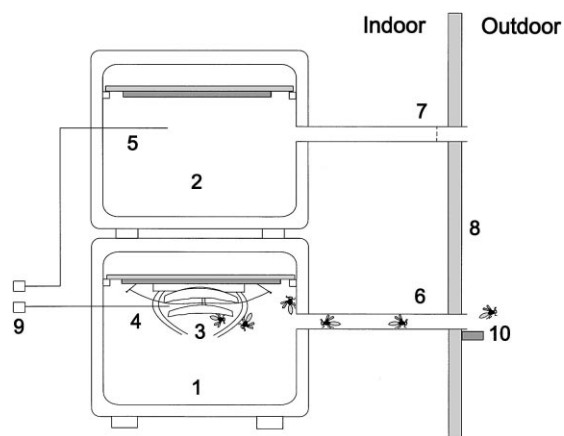

Fig. 2. Twin set-up of two camping box calorimeters (PMCs) for the investigation of a hornet nest (lower box) with entrance duct and two thermocouples for temperature measurements in both boxes. 1: Measuring chamber; 2: reference chamber; 3: nest; 4,5: thermocouples; 6: entrance duct to the nest; 7: entrance duct closed with a grid; 8: wall; 9: thermo logger; 10: entrance support.



Fig. 3. Golden hamster (*Mesocricetus auratus*) in a camping box calorimeter (PMC) with cover lifted. For further details see text.

mammals like mice and hamsters, as well as birds are possible objects. Aquatic animals like turtles or fish are less suited because of the high heat capacity of the surrounding water and the significant increase in the calorimetric time constant.

In a PMC of 10 l active volume, about 2 l oxygen are available. When a hamster of 160 g and a heat production rate of 1.6 W [12] is enclosed in the calorimeter (see Fig. 3) oxygen is consumed at a rate of 300 ml/h (because of an oxycaloric equivalent of 450 kJ/mol or 20.1 J/ml oxygen). Then, air has to be pumped through the PMC at a minimum rate of 1.5 l/h to guarantee normal physiological conditions for the animal. To avoid thermal disturbances this airflow is pumped through a heat exchanger coil or plate (e.g. taken from the backside of an old refrigerator) situated near the PMC inside a common styrofoam insulation. The outflowing air may be sent through a solution of barium hydroxide to absorb carbon dioxide in an exactly determined time interval. Later on the absorbing liquid can be titrated with oxalic acid to evaluate the respiration rate of the animal (indirect calorimetry) [9]. Moreover, water loss and thus heat of evaporation (2.4 J/mg water, [13]) during the experiment can be determined by the increase of humidity inside the box at stopped-flow experiments or by the weight

increase of a suited absorber during a selected time of air flow.

2.2. The Lotus calorimeter

Although plants in general are known to have low metabolic rates compared to animals some plants exhibit a significantly increased metabolism during the time of flowering to volatilize floral scents for attracting insect pollinators [14,15]. In this thermogenic period the flower temperature may go up to as high as 35°C above ambient. Usually, blossom temperatures fluctuate with changes in the environmental temperature but three plants are known to keep their inflorescence temperatures fairly constant for several days [16–18], among them the sacred lotus *Nelumbo nucifera* [4]. Lotus holds the flower temperature between 30 and 35°C for about 4 days—even when the ambient temperature changes by more than 10–20°C [4,7].

In preparing a research visit to Adelaide, Australia, to measure the heat output of blossoms of the sacred lotus and its performance of thermoregulation in its natural environment, a first field calorimeter was developed. At that early time the true experimental conditions in and around the lotus pond of the Bota-

Table 1
Characteristic transition data for some chemical compounds applicable for the Lotus calorimeter

Compound	Fusion temperature (°C)	Heat of fusion (J g ⁻¹)	Heat of fusion (J cm ⁻³)
Water	0.0	333.7	334
Formic acid	8.4	276.0	337
Dioxan	11.7	143.1	148
Acetic acid	16.6	186.7	196
Glycerol	18	200.4	252
Diphenylmethan	24.7	109.4	110
Diphenyl ether	26.9	101.1	106
Methylacetamid	29.5		
Diaminodiphenyl	30		
Trimethylacetic acid	35		
Phenol	40.8	123.3	132
Diphenylbutane	52.3	231	
Diphenylamine	52.5	103.4	109
Naphthalene	80.2	148.2	145

nical Gardens in Adelaide were not known correctly so that the instrument became too large and too heavy for a routine study (compare with the wine cooler calorimeter below). Moreover, it was based on the assumption that there was a firm ground in the pond to put three unipods on it carrying the calorimeter. In reality it was very muddy with a lot of rhizomes, and long wooden stakes had to be ramped into it to guarantee a fixed position (see below and Fig. 7).

The single vessel version was based on the idea to use a chemical system with a reversible phase transition as the heat sink to enable stable isoperibolic

conditions—at least for several hours when no connection to the mains were possible. Several compounds with temperatures in the wanted range were found in the literature (Table 1). A rectangular cubic calorimetric vessel of 20 cm×20 cm×20 cm was produced from aluminium plates of 0.4 cm thickness for the side walls and the top (1 in Fig. 4). The bottom remained open since the vessel should be placed over a blossom from the top. The bottom was chosen as part of the general perpex plate (10) supporting the whole calorimeter. In its center a separate circular perpex plate (4) of 16 cm diameter with a central hole of 2 cm

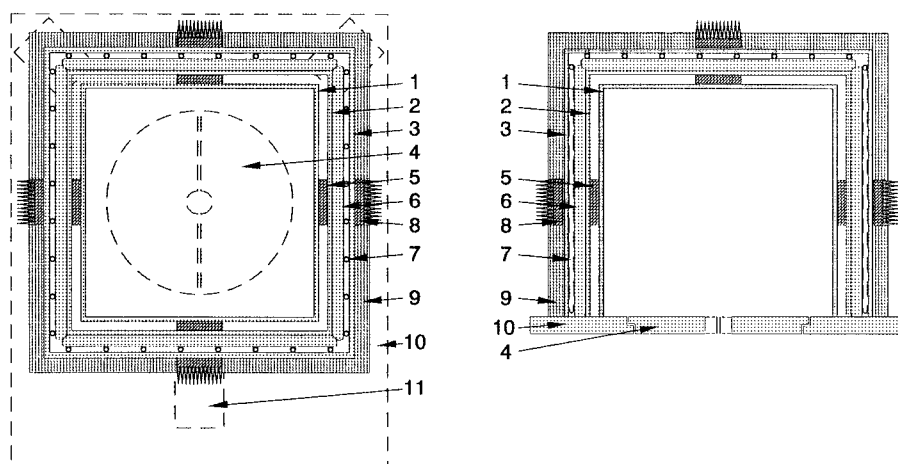

Fig. 4. Sketch of a horizontal (left) and vertical (right) cross-section of the Lotus calorimeter. 1: Inner cube; 2: middle cube; 3: outer cube; 4: halved bottom plate with the stalk hole; 5: heat flow sensors; 6: heat sink cushions; 7: tubing system; 8: Peltier coolers with heat sinks; 9: styrofoam insulation; 10: perpex plate; 11: support for unipods.

rested on the support. This circular plate was divided into two halves which could be shifted around the stalk of the lotus blossom preventing air circulation and heat exchange with the environment.

The side walls and the top of the vessel were connected to a second concentric aluminium cube (2) of 0.5 cm thickness by means of five heat flow sensors (5) of 4 cm×4 cm (Peltier heat transducers Type TEC1-12705). This second or middle cube was part of the larger heat sink and thermostat consisting of a third (outer) cube (3) of 0.5 cm aluminium walls and a set of five flat plastic cushions (6) with thermostating solution. These cushions filled the space between the outer and the middle cube as tight as possible. The cushions were prepared from polyethylene bags as used for deep-freezing of foodstuffs. They were filled with the chosen liquid, were placed in such a way that all air bubbles could escape and then were sealed by welding to the correct sizes of 16 cm×24 cm for the walls and 25 cm×40 cm for the top. Between the cushions and the outer cube a system of copper tubes (7) was installed. It could be connected to a water bath

of lower temperature when the calorimeter was brought back to the lab after a field investigation. Thus, the calorimeter could be cooled down at the end of an experiment to reverse the melting process and prepare the instrument for the next run.

For an afield situation with a mains connection accessible five regulated heat pumps (8; Peltier heat transducers as described above, connected to heat sinks) were placed on the surface in good thermal contact with the outer cube while the rest of the surface was covered by a 4 cm styrofoam layer (9) shielded against the strong Australian irradiation by a thin aluminium foil. Moreover, the outer cube carried three supports (11) to which the unipods could be screwed. These were commercial foto equipment variable in length so that the calorimeter could be adjusted to the height of the blossom. The real set-up of the calorimeter during construction can be seen in Fig. 5.

To realize such an isothermal calorimeter a manifold of liquids with phase transitions in the wanted temperature range can be found. As long as pressure

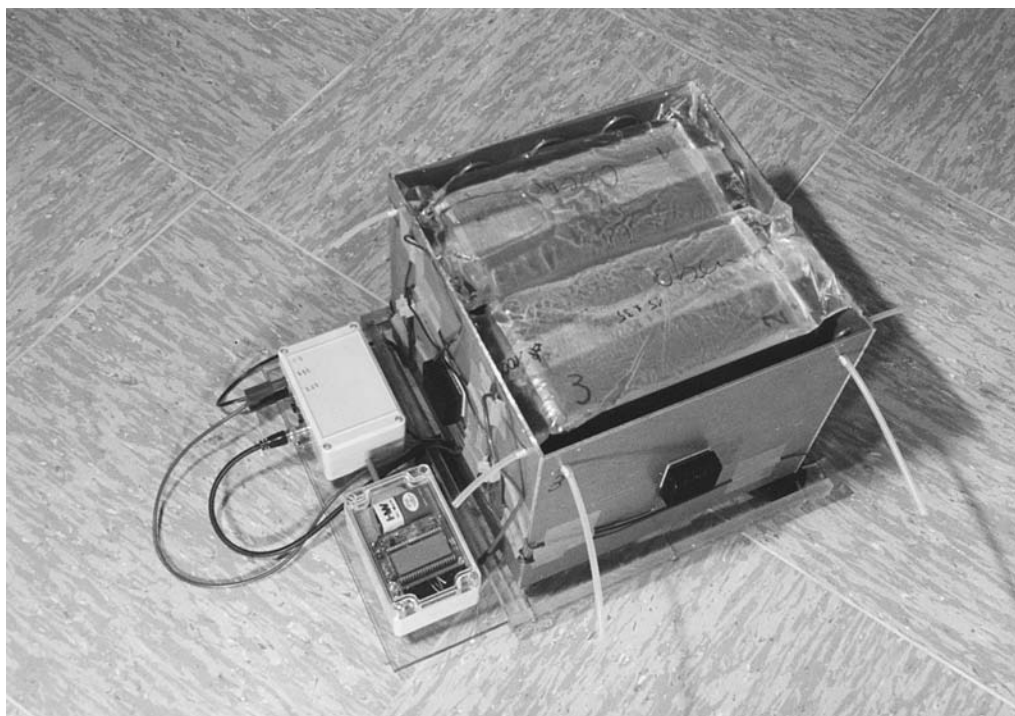

Fig. 5. View of the disassembled Lotus calorimeter with the outer cube carrying two Peltier coolers (in front and left), two heat sink cushions on top, the upper ends of the tubing system and the temperature regulator and indicator at the left.

remains constant, transition temperature does not change either. Besides the well-known ice calorimeter of Lavoisier and Laplace operating with water at 0°C, other substances are cited in the literature, e.g. diphenyl methane (fusion temperature 24.7°C), diphenyl ether (26.9°C) or naphthalin (80.2°C) [19]. In Table 1 some possible liquids are compiled in the order of their fusion temperature. Although the heat of fusion itself is not important for the present purpose, the heat of fusion per volume or mass is of interest as it determines how much energy can be exchanged by a given amount of substance and thus how long the isothermal condition can be sustained. In this sense, formic acid and glycerol are interesting candidates besides water. But other non-thermal characteristic parameters like acidity, aggressivity, flammability or toxicity may be significant for the choice. Further approaches to a non-electric, physico-chemical thermostatting may be found in papers dealing with energy storage materials, e.g. [20,21].

Moreover, there are some disadvantages working with a liquid in plastic bags in the calorimeter. Gels could increase reliability. Commercial eutectics, especially in combination with gels of high viscosity, already sold in plates as *CoolPacks* for cold-store and professional kitchen installations could be an interesting alternative for the construction of such a calorimeter—if they would be available not only for sub-zero temperatures, but in the biological range.

Although the Lotus calorimeter could not be applied for the planned purpose some preliminary investigations were run to determine its sensitivity, baseline stability and time constant. An electric calibration rendered a sensitivity of 42.4 mV/W, comparable to those of commercial instruments.

2.3. The wine cooler calorimeter (WCC)

The intention of the investigations in Adelaide was an in situ determination of the heat output of intact lotus flowers in parallel with a forthcoming indirect calorimetry of oxygen consumption and temperature increase. As the sacred lotus was growing in a pond in the Botanic Gardens (Adelaide) a special light and transportable calorimeter had to be developed working sufficiently well under the harsh temperature conditions of the Australian summer. The instrument had to

be placed over the flower approximately 100 cm above the water level. As ambient temperatures could change significantly during day and night only a twin set-up was applicable of two identical units connected differentially. As all recordings of heat production, oxygen consumption, and temperatures of the two calorimetric vessels, the blossom and the environment had to be done at the pond site a long-time data logger was used throughout the investigation.

The two identical calorimetric units were built from inverted commercial dry wine coolers (1 in Fig. 6) of 100 mm inner and 120 mm outer diameter, resp., 185 mm internal and 220 mm external height and a 5 mm space between the two walls. They were equipped with water inlet and outlet tubes (2) connected to a thermostatted waterbath at the side of the lotus pond. An aluminium plate (3) was glued to the inside bottom of the cooler to render a good thermal contact to the heat sink, i.e. the thermostatted water in the wine cooler. The calorimetric vessel proper was a thin walled (biscuit) tin of 80 mm diameter and 145 mm height (4) carrying another aluminium plate (5). A Peltier element (6) (40 mm×40 mm×4 mm, Type TEC1-12705) was fixed to this plate after application of a heat transfer compound to the first aluminium plate. A styrofoam insulation (7) between tin and inner cooler wall guaranteed that the largest portion of heat produced within the tin would flow through the Peltier element to the heat sink. Both, tin and cooler were closed with stoppers (8) cut from 20 mm foam plates (Fig. 6). As both sides of this twin calorimeter should be thermally identical the usual heat capacity of 140 J/°C for a lotus flower with a mean mass of 42.2 g was compensated in the reference vessel by a plastic container with styrofoam and 33.8 g of water (not shown). For simultaneous indirect calorimetric determinations of plant metabolism a silicon tube (not shown) was wrapped around the wine cooler as heat exchanger for the inflowing air. Heat input or loss due to not fully equilibrated outside air could be calculated from temperature differences [7].

Both complete devices of cooler, tin and Peltier element were housed in a cubic styrofoam box (9) used for shipping fragile products. The space between the circular cooler and the walls was filled with further insulating material (10). Both styrofoam boxes of the twin set-up were firmly connected to each other and covered altogether with aluminium foil for good sun

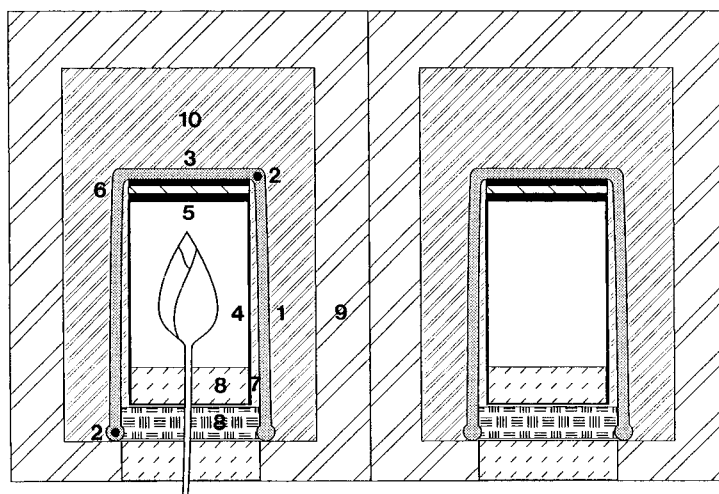

Fig. 6. Vertical cross section of the wine cooler calorimeter (WCC) with the measuring vessel (left) and the reference vessel (right). 1: Inverted commercial dry wine cooler; 2: water inlet and outlet tubes; 3: aluminium plate glued to the bottom of the cooler; 4: biscuit tin; 5: aluminium plate glued to the bottom of the tin; 6: Peltier element; 7: styrofoam insulation; 8: flexible foam stoppers; 9: styrofoam box; 10: insulating material. Adapted from [7].

light reflection. The water flows of both coolers were connected in parallel to ensure relations as similar as possible. The whole ensemble was fixed to wooden stakes of 40 mm×40 mm and 2000 mm length which were rammed into the ground of the pond. A further stake carried an umbrella to render shadow to both calorimetric halves the most time of the day (Fig. 7).

The sensitivity of the calorimeter amounted to 29.3 mV/W, nearly identical for both sides. With an expected power output of lotus flowers of up to 1 W maximum, signals of about 30 mV had to be registered. The time constant of the calorimeter figured at 93 s for a reduction to 50%. The long-time baseline stability of the set-up was tested under severe conditions. The baseline fluctuated less than 1% of the 50 mV range during 24 h inspite of temperature differences of about 40°C. Such deviations are negligible at the power output of the lotus flowers.

As the sacred lotus *Nelumbo nucifera* grew in a quasi natural pond in the Botanic Gardens (Adelaide), one had to enter the pond with high wader to install the calorimeter over the lotus flower buds since the water plus mud depth amounted to about 60 cm supposedly the most exotic place for calorimetry ever used (see Fig. 7).

2.4. The enzyme calorimeter

In 1976, Pennington already described a small and simple microcalorimeter based on a 0.9 cm×0.9 cm Peltier unit detector and developed for laboratory investigations [22]. But with some minor modifications it may be easily adapted for afield applications. In the original version a perspex cylinder is attached to a foam block glued to a larger plate of metal which serves as anchor holding the calorimeter firmly in the surrounding waterbath. The Peltier unit rests on the foam block as a heat flow sensor. A microliter syringe placed in the waterbath enters with its needle through the perspex cylinder just onto the surface of the heat sensor.

In an experiment, 5–50 µl of the first reactant are placed onto the sensor by another syringe. It forms a drop shape on the detector due to its surface tension, so that no further vessel as in other calorimeters is necessary. After equilibration of the liquid to the working temperature (within less than a minute) the second reactant is added from the first syringe placed in the waterbath and thus being also at the working temperature. To avoid evaporation effects, the perspex cylinder is closed by a stopper and a piece of wet filter paper is attached to the inner wall. With such a small

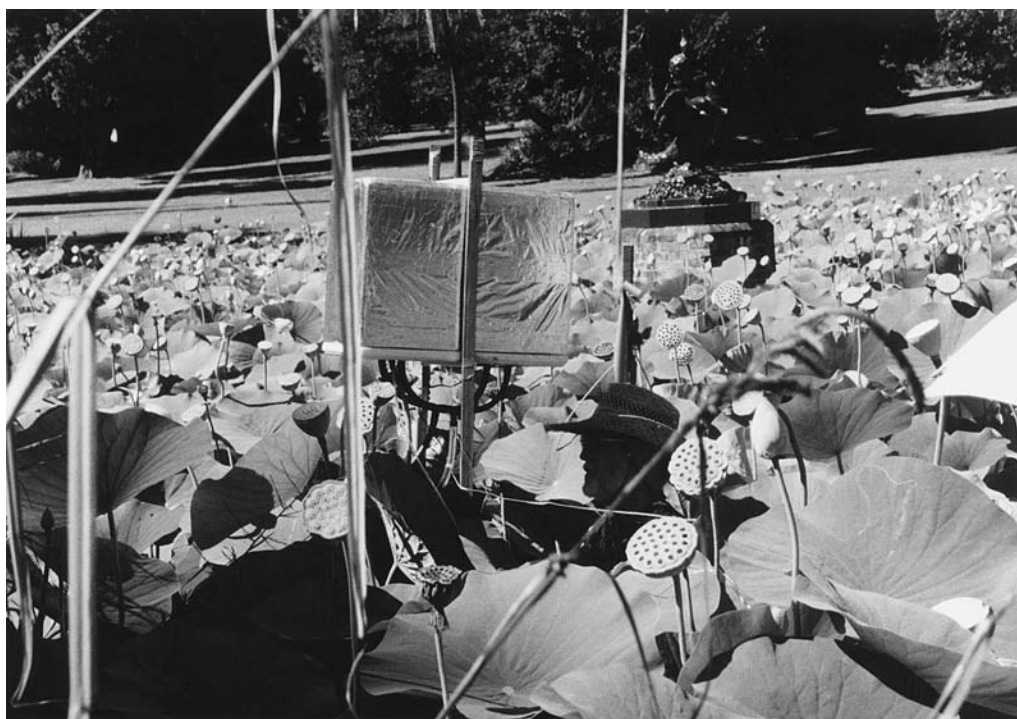

Fig. 7. Installation of the wine cooler calorimeter (silver box between two stalks) in the lotus pond of the Botanical Gardens in Adelaide. The size of the calorimeter can be estimated from the head visible at the lower right corner of the instrument.

droplet stirring can be avoided since diffusion and mixing of the two reactants guarantee for a complete thermal homogeneity.

A slight modification of the Pennington calorimeter was used for more than 20 years in our laboratory as a simple demonstration instrument for students. They investigated inorganic and enzymatic reactions during practical courses. From these own experiences and the data published in the original paper [22] one can deduce the following characteristic figures for the calorimeter: sensitivity about 40 mV/W, time constant 10 s half life time, equilibration time 15–30 s, sample sizes 10–100 μl , detection limit less than 20 mJ. To our knowledge this instrument was only used in the laboratory, but with its high sensitivity and small time constant no special precautions are necessary concerning the baseline shift during a single experiment. This very simple, easy to construct calorimeter was never used afield — as far as we know — but interesting applications are conceivable as with the instruments presented in the next paragraph.

2.5. Integrated circuit calorimeters

Since the days of Calvet and Prat [23] most biologically applied calorimeters were so-called *microcalorimeters* although the specimens used were in the milliliter range [24]. With the progress of miniaturization planar chips became available which could be converted to small, sensitive and quick heat flow sensors called *integrated circuit (IC) calorimeters*. Because of their sample sizes of a few microliter and their detection limit of some nW this kind of instruments was also named *nanocalorimeters*. Wolf and his group in Freiberg, Germany, published a series of interesting papers dedicated to small sized IC instruments and their application in different fields of thermal analysis [1,25–27]. They were built from silicon chips (Xensor Integration, Delft, Netherlands) with integrated heat flow sensors and calibration resistances, offering the possibility to place the liquid sample directly onto the surface of the chip (see the Pennington calorimeter above).

These calorimeters were constructed as batch, gas flow-through and scanning instruments. Due to the small size parasitic heat capacities and disturbances by external temperatures could be strongly reduced. The sensitivity amounted to 2.5 V/W. In batch experiments it was essential to apply a wetting ring to the inside of the calorimeter to allow for a faster vapour pressure equilibration and thus for a short time to prepare the next run [1]. Investigations were run on enzymatic reactions, oscillatory processes and solid–gas interactions [25].

A further development concerning these chips went for an electronic nose, a calorimetric sensor module based on such chips and suited host compounds to absorb gas molecules in a selective manner [26,27]. As the clathrate formation was coupled with an enthalpy change thermal sensors were able to detect organic vapours. Up to eight thermopile chips in two packages were incorporated into a small calorimeter mounted in a standard 19 in. plug-in unit. Characteristic features were a power resolution of about 100 nW and a sufficient temperature stability even without room thermostating.

Although these nanocalorimeters were never used outside the laboratory—just as the Pennington calorimeter mentioned above—they seem to be suited very well for afield applications due to their small size, low time constant, high sensitivity and lack of thermostating demands. In a further paper the authors also showed that the influence of external temperature perturbations on the calorimetric output could be strongly reduced, enabling even the construction of a non-differential chip calorimeter without thermostating. To this end it was necessary to measure the external temperature and to predict and correct the perturbation part of the output signal. A parametric model was used for the identification and rendered a good mathematical description of the calorimeter and a high stability of the system [28].

2.6. SETline portable thermal analyzer

SETARAM, Lyon, has developed the first transportable hightech calorimeter based on the planar chips used by Wolf, Lerchner and colleagues (see above, [1,25]). This chip of 28 mm×28 mm consists of 160 Al/Si thermocouples as heat flow transducer, a temperature sensor and a calibration resistor for the Joule

effect. The chip is placed in an aluminium thermostat which is kept at the chosen temperature by means of two Peltier elements.

The main features of this transportable 10 kg calorimeter are a high sensitivity of up to 2000 mV/W, a small time constant of 1–2 s, a set-up time of a few minutes for the next experiment, a rapid cooling from 120 to 25°C within 5 min because of the small mass of the heat sink, enabling about four scanning experiments per hour, as well as small samples of a few milligrams. They can be placed directly on the chip without any crucibles (see the Pennington calorimeter above) since the chip surface can be easily cleaned. This non-differential isoperibol and scanning calorimeter works in a temperature range from –10 to +120°C with easily exchangeable chips, with a power supply from the mains or batteries and may be connected to a portable PC for data acquisition and handling. The operation time with batteries is around 4 h. Most experiments up to now are run in the DSC mode with heating rates up to 10 K/min, concerning e.g. food processing with crystallisation, gelatinization or melting. The instrument is aimed at quality control, routine analysis or screening investigations. Fig. 8a shows a cross-section through the calorimeter head with the chip (*integrated circuit*), the chip carrier below it and the two Peltier elements for thermostating. The indicated crucible is not obligatory in the experiments (as mentioned above). Part b gives an impression of the size and the arrangement of the chip after turning away the enclosing thermostat.

The SETline calorimeter has been commercially available only recently so that biological experiments have not been possible yet. With the high sensitivity and the small sample sizes investigations in the field of ecological monitoring and environmental protection seem possible.

2.7. Dewar vessel calorimeter

The supposedly easiest way of an afield calorimeter is a simple Dewar vessel from glass or metal (like those used as thermos in daily life) equipped with a temperature sensor. This might be a usual thermometer for direct reading or a data logger with external thermistor (e.g. HOBO Temp, Onset Computer Co., Pocasset, USA). Rotting of biological material like household or garden litter, manure or even material

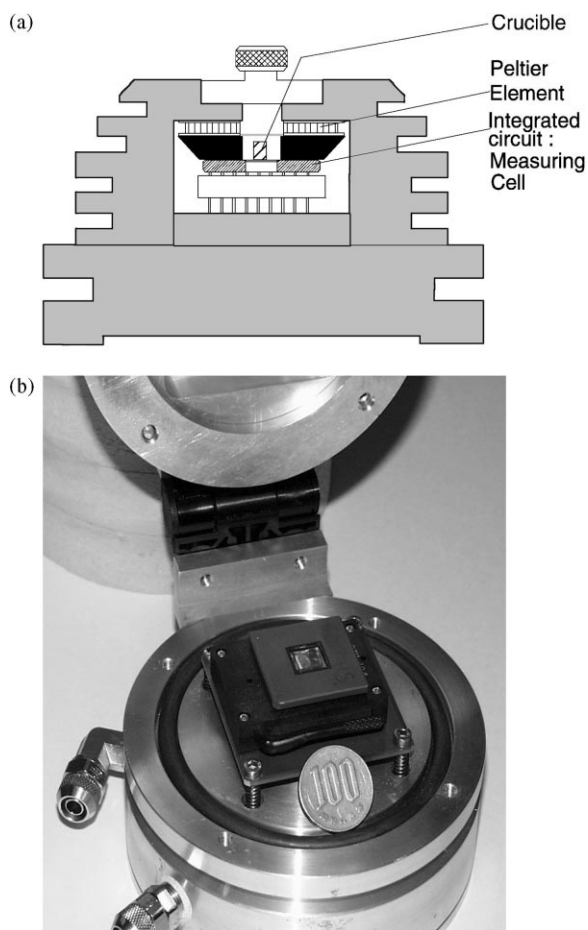

Fig. 8. (a) Cross-section of the head of the SETARAM SETline portable thermal analyzer with the heat flow transducer chip and the two Peltier elements of the aluminium thermostat. (b) View into the opened thermal analyzer with the chip and its support (by courtesy of SETARAM, Lyon). For further details see text.

from the center of an ant hill often show very large heat production rates leading to high temperatures. The authors observed up to 80°C in simple Dewar vessels with freshly cut grass or nest material of ants [29,30]. Some care has to be taken with the stopper since that is the part of strongest heat leakage of the system. Chemical [31,32] or electrical calibration by the Joule effect will render information of the heat capacity of the system, of cooling rates and offer possibilities for corrections.

An even simpler calorimeter has been proposed recently via the internet: a usual coffee cup from styrofoam instead of the more fragile Dewar vessel

[33]. This system was recommended for short term chemical reactions in liquid phase with high heat output, but it might be suited as well for strong biological processes like fermentation although the heat loss to the environment is large. Moreover, it underlines that fantasy and leaving down worn tracks help to find cheap and attractive solutions.

3. Conclusions

The present paper offers ideas and realities, low price solutions (e.g. the PMC) and hightech instruments (e.g. the SETline). There are fields in biology and biochemistry like kinetic investigations or quantitative measurements on rare substances of small amounts where only the most sophisticated calorimeters are suited to gain valuable data. But at the same time, there are other fields of more qualitative or analytical approach where simple solutions can be found with instruments which are customer made by scientists with low financial budgets. The authors investigated the metabolism of whole plants with commercial LKB instruments [34] as well as with the WCC for \$ 100, [7] or the influence of pheromones on social insects with Calvet batch set-ups as well as with a twin PMC [11,35]. It is their own experience in many years of biological calorimetry that it is not always worthwhile to search for a commercial offer that could be adapted to the present demand but much better to find a simple, cheap and quick solution which is constructed in one or a few days just for that special problem and put aside later on.

In this sense the authors hope that they could stimulate the reader's imagination and fantasy and open his eyes for an interesting and appealing field of (biological) calorimetry.

References

- [1] J. Lerchner, R. Oehmgen, G. Wolf, T. LePaleur, J.-L. Daudon, High temperatures—high pressures 30 (1998) 701.
- [2] I. Wadsö, *Chem. Soc. Rev.* 26 (1997) 79.
- [3] U. von Stockar, I.W. Marison, *Thermochim. Acta* 193 (1991) 215.
- [4] R.S. Seymour, P. Schultze-Motel, *Nature* 383 (1996) 305.
- [5] R.S. Seymour, *Thermochim. Acta* 193 (1991) 91.
- [6] E. Schmolz, I. Lamprecht, B. Schrickler, *Thermochim. Acta* 251 (1995) 293.

- [7] I. Lamprecht, R.S. Seymour, P. Schultze-Motel, *Thermochim. Acta* 309 (1998) 5.
- [8] T. Wesolowski, I. Lamprecht, B. Schaarschmidt, *J. Therm. Anal.* 30 (1985) 1403.
- [9] P. Schultze-Motel, I. Lamprecht, *Thermochim. Acta* 119 (1987) 157.
- [10] P. Schultze-Motel, *Thermochim. Acta* 193 (1991) 57.
- [11] I. Lamprecht, *Thermochim. Acta* 300 (1997) 213.
- [12] I. Lamprecht, A.I. Zotin, *Thermodynamics of Biological Processes*, De Gruyter, Berlin, 1978.
- [13] N.B. Vargaftik, *Tables on the Thermophysical Properties of Liquids and Gases*, Hemisphere, Washington, London, 1975.
- [14] G. Gottsberger, *Naturwiss. Rundsch.* 39 (1986) 350.
- [15] R.S. Seymour, G.A. Bartholomew, M.C. Barnhart, *Planta* 157 (1983) 336.
- [16] R.M. Knutson, *Science* 186 (1974) 746.
- [17] R.M. Knutson, *Nat. Hist.* 88 (1979) 42.
- [18] K.A. Nagy, D.K. Odell, R.S. Seymour, *Science* 178 (1972) 1195.
- [19] W. Hemminger, G. Höhne, *Calorimetry—Fundamentals and Practice*, Weinheim, Deerfield Beach, Basel, 1984.
- [20] M.W. Babich, S.W. Hwang, R.D. Mounts, *Thermochim. Acta* 210 (1992) 77.
- [21] M.W. Babich, S.W. Hwang, R.D. Mounts, *Thermochim. Acta* 210 (1992) 83.
- [22] S.N. Pennington, *Anal. Biochem.* 72 (1976) 230.
- [23] E. Calvet, H. Prat, *Microcalorimétrie—Application Physico-chimiques et Biologiques*, Masson et Cie, Paris, 1956.
- [24] A.E. Beezer, *Biological Microcalorimetry*, Academic Press, London, 1980.
- [25] J. Lerchner, A. Wolf, G. Wolf, *J. Thermal Analys. Calor.* 57 (1999) 241.
- [26] J. Lerchner, D. Caspary, G. Wolf, in: *Proceedings of the 11th International Trade Fair Conference Sensors, Transducers and Systems*, Nürnberg, 1999, C 10.3.
- [27] J. Lerchner, J. Seidel, G. Wolf, E. Weber, *Sensors Actuators B* 32 (1996) 71.
- [28] J. Lerchner, G. Wolf, A. Torralba, V. Torra, *Thermochim. Acta* 302 (1997) 201.
- [29] H. Bolouri, I. Lamprecht, B. Schaarschmidt, in: W. Hemminger (Ed.), *Thermal Analysis*, Vol. 2, Birkhäuser, Basel, 1980, 577.
- [30] I. Bachem, I. Lamprecht, B. Schaarschmidt, in: W. Hemminger (Ed.), *Thermal Analysis*, Vol. 2, Birkhäuser, Basel, 1980, 571.
- [31] A.-T. Chen, I. Wadsö, *J. Biochem. Biophys. Methods* 6 (1982) 297.
- [32] L.-E. Briggner, I. Wadsö, *J. Biochem. Biophys. Methods* 22 (1991) 101.
- [33] <http://genchem.chem.wisc.edu/labdocs/modules/calorimt/cal-desc.htm>.
- [34] I. Lamprecht, K. Drong, B. Schaarschmidt, G. Welge, *Thermochim. Acta* 187 (1991) 33.
- [35] E. Schmolz, T. Scholz, I. Lamprecht, *Nachr. Chem. Tech. Lab.* 47 (1999) 1095.