



ELSEVIER

Thermochemica Acta 365 (2000) 111–117

thermochemica
acta

www.elsevier.com/locate/tca

Measurement of shrinkage behaviour in leather and parchment by dynamic mechanical thermal analysis

Neil S. Cohen^a, M. Odlyha^{a,*}, G.M. Foster^b

^a*School of Biological & Chemical Sciences, Birkbeck College, University of London, Gordon House, 29 Gordon Square, WC1H 0PP UK*

^b*School of Engineering and Computer Science, University of Exeter, North Park Rd., Exeter, Devon EX4 4QF, UK*

Abstract

The mechanical behaviour of modern and historic parchment and leather samples through their shrinkage temperature is described. The measurements are made possible by the novel modification of a standard dynamic mechanical thermal analyser (Rheometric Scientific DMTA Mk3) to enable experiments to be conducted on samples immersed in water. A sample of parchment was clamped in tensile mode under a small static applied force. The temperature of the water could be controlled and thus it was possible to heat the sample and monitor the change in its displacement as it passed through the shrinkage temperature. Information could therefore be obtained on the percentage shrinkage and the temperature range over which it occurred. Furthermore, the method also provided useful information on the expansion or contraction of the samples on initial immersion in water, which relates to ease of sample wettability, and on the changes during drying process and rehydration.

© 2000 Elsevier Science B.V. All rights reserved.

Keywords: Dynamic mechanical thermal analysis; Parchment; Leather; Collagen; Hydrothermal stability; Shrinkage

1. Introduction

This paper deals with the study of the mechanical behaviour of parchment and leather samples in water and on drying. Previous measurements using thermo-mechanical and dielectric techniques have been carried out on aged and unaged leather samples and the effect of sample heating explored [1]. In this paper, the effect on the mechanical properties of heating the sample while immersed in water are further explored. The parchment samples were provided by the School of Conservation, Copenhagen and the leather samples from the National Trust, England. The parchment samples are from a variety of sources, mainly book-bindings from the Royal Library, Denmark [2]. The

historical parchments are based on animal hide which is either of calf, sheep, or goat origin; modern parchments which were used as reference materials were based on calf hide. They are described in Table 1.

As described in the preceding two papers the hydrothermal stability of collagen fibres is a particularly good measure of the strength or quality of skin, leather and parchment materials, and the degree of their deterioration. The hydrothermal stability is characterised by a shrinkage of the material when heated in water at a defined temperature. The preceding two papers have described how this parameter can be measured using thermomicroscopy and differential scanning calorimetry [3,4]. In this paper a novel method is proposed which measures the shrinkage of the sample under uniaxial loading. This was made possible through adaptation and modification of a Rheometric Scientific Dynamic Mechanical Analyser

* Corresponding author.

E-mail address: m.odlyha@bbk.ac.uk (M. Odlyha).

Table 1
Description of modern and historic parchments

Parchment	Thickness (mm) ^a	Description
NP3	0.19	Modern parchment. Beige, soft, flexible, smooth upper face, furry speckled underside
NP7	0.16	Modern parchment. Beige, soft, thin, flexible, smooth, speckled underside
HP8	0.28	1797–1799 bookbinding. Grey/brown face with ink marks, white ground backing, curled, brittle
HP22	0.36	Brown/white markings, roughened, flexible, curled, slightly translucent
HP28	0.24	Bookbinding. Yellow/brown upper side, pale underside, flexible

^a Thickness measured before removal of any backing/coating layers.

(Mk3). The use of it in this way will be referred to as Reverse Configuration DMTA and is described in detail elsewhere [5]. It was designed and first used in a project involving testing of textiles [5]. These experiments were all conducted with the samples immersed in water. However, the effects of dehydrothermal treatment of collagen have also been studied (reported in this volume) and have shown to alter molecular packing in collagen on water removal [6].

2. Experimental

The DMTA measuring head was turned upside down and extension rods were fitted to the drive shaft and to the pillars that support the sample clamps. This enabled the sample to be clamped and immersed in a beaker of water, at a distance from the main DMTA

measuring head. An expanded view of this part of the apparatus is shown in Fig. 1. Water was pumped and continuously circulated through the beaker by means of a water bath (Grant Instruments, Cambridge) which also enabled controlled heating to be performed. The temperature was measured using the DMTA thermocouple, which was also fitted with extended leads to enable it to be immersed with the sample in the beaker.

The sample (20 mm × 10 mm) was mounted in the tensile mode, and a small (0.1 N) static force was applied along the length of the sample. This would enable any expansion or contraction of the sample during immersion or drying to be measured. A low static force was used so that the measured shrinkage would not be overwhelmed by the applied force. The method of measurement used here is referred to as creep since the change in displacement of the sample is recorded as a function of time [7].

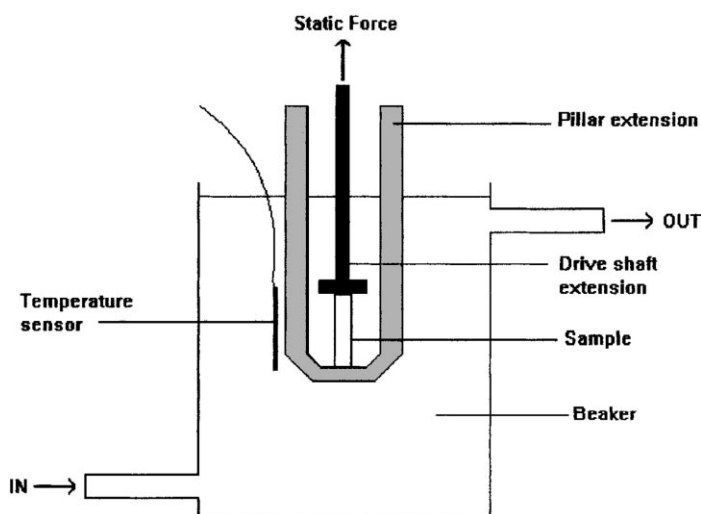

Fig. 1. Expanded view of sample immersed in beaker. The drive shaft and pillar extension connect to the DMTA analyser.

The experiment commenced with the sample initially in air, to give a starting baseline. After 10 min, the sample was immersed in the beaker of water, at a temperature of 30°C. Subsequently the temperature of the water bath was increased in 5°C steps every 10 min, until a maximum temperature of 85°C was reached. The sample was then removed from the water bath and left to dry at room temperature. Since the temperature was increased manually in a stepwise manner, each reading will only be accurate to the nearest 5°C. If greater accuracy in temperature was required then smaller steps could be used. However, the emphasis in this experiment was the measurement of displacement rather than temperature as this can be

made more accurately using thermomicroscopy as described in the previous paper [3].

3. Results

Curves for NP7 and HP28 are shown in Fig. 2. The graphs were plotted as percentage displacement (y-axis) against time (x-axis), with the temperature profile superimposed (y2-axis). The stepwise increase in temperature from 30 to 85°C in between 10 and 130 min can be seen in Fig. 2a. Then there is a sharp decrease from 85 to 18°C as the sample is removed from the water. As surface water evaporates from the

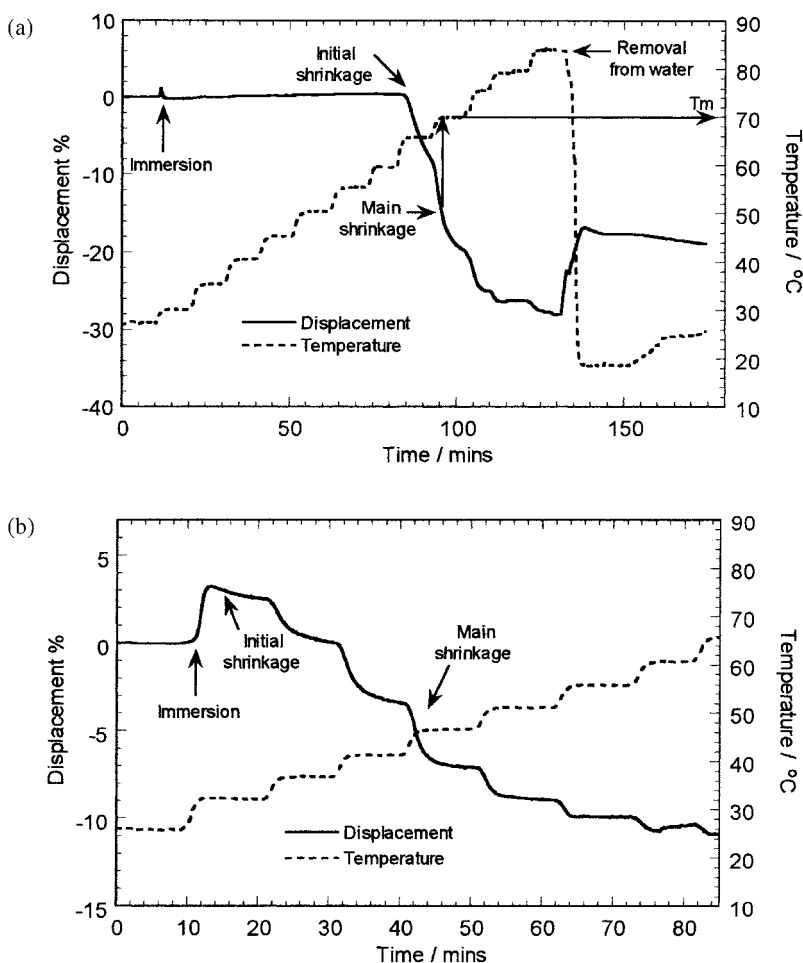

Fig. 2. Percentage displacement on immersion in water and on heating plotted as a function of time for (a) NP7 and (b) HP28. Temperature is calculated as shown in (a).

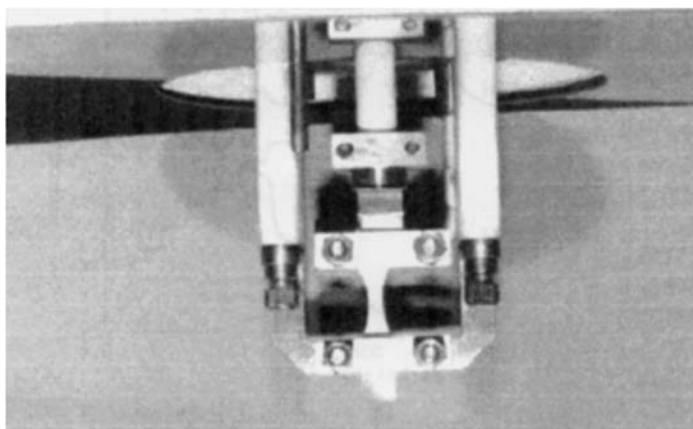

Fig. 3. Parchment sample in tensile clamps after removal from water.

thermocouple and it dries there is a return from 18°C to room temperature (24°C).

On initial immersion in water the displacement trace of unaged sample NP7 (Fig. 2a) shows a slight blip, but there is little overall change in the sample dimensions. By comparison, historic parchment HP28 showed a 3% expansion in length (positive displacement) as water is absorbed during initial immersion, indicating that the sample had softened and could be stretched more readily once it has been wetted.

On heating, before the initial shrinkage temperature, samples generally showed a very small expansion (<1%). In the unaged sample NP7 there was no change until a temperature of 65°C at which point the sample started to shrink rapidly. The main shrinkage (i.e. the largest single change in displacement) as marked on Fig. 2a was complete at 70°C. The measurements were repeated five times and the same amount of shrinkage and temperature range over which shrinkage occurred were recorded.

At the other extreme, sample HP28 (Fig. 2b) showed signs of shrinkage immediately on immersion in water at 30°C. The shrinkage steps were also much more even in magnitude and distributed over a wider temperature range than those seen in the modern parchment, where most of the shrinkage occurred over a 10°C temperature interval.

In Fig. 2a, it can be seen that most of the shrinkage is complete by 80°C. The sample was removed from the water at 85°C, at which point there was a significant partial recovery in sample dimension (10% expansion), although the final dry sample was still

18% shorter than originally. Furthermore, on completion of the experiment the rectangular piece of parchment was seen to have bowed (concave) edges, providing physical evidence that shrinkage had occurred. This can be seen in the photograph of Fig. 3.

Similar results to the parchments were found for measurements on a sample of unaged leather as shown in Fig. 4 (although 10°C heating steps were used in this case). On initial heating there is a slight expansion as the leather softens in water, but at 70°C there is a sharp and rapid shrinkage, resulting in a 25% decrease in sample length. The shrinkage is virtually complete within the 10 min step for which the water is maintained at 70°C, and there is little further change on continued heating. However, unlike in the unaged parchment sample, in the unaged leather there was no partial recovery in dimensions on removal from water and cooling.

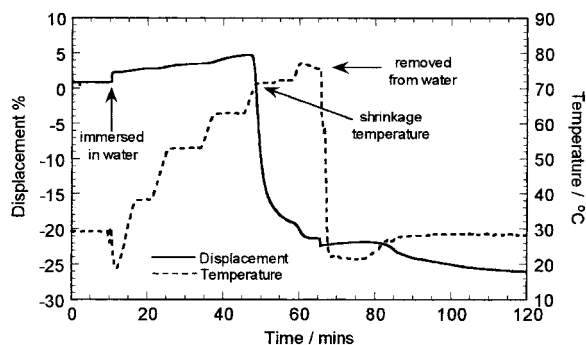

Fig. 4. Percentage displacement on immersion in water and on heating plotted as a function of time for modern (unaged) leather.

Table 2
Summary of displacement (%) on immersion in water and then shrinkage (%) on heating in water and recovery on drying (%)

Parchment	Change on immersion (%)	Temperature of initial shrinkage, T_i (°C)	Temperature of main shrinkage, T_m (°C)	$T_m - T_i$ (ΔT) (°C)	Main shrinkage (%)	Total shrinkage (%)	Shrinkage ratio, R	Recovery on drying (%)
NP7	-1.0	65	70	5	20	30	0.67	10
HP28	3.2	30	45	15	7	15 ^a	0.47	×
HP8 (first)	1.5	35	55	20	16	30	0.53	10
HP8 (second)	11.0	35	60	25	4	15	0.27	3

^a Figure approximate as sample split towards end of experiment. Actual value therefore slightly higher.

From the data shown in the figures, the following parameters could be measured:

1. *Percentage displacement change (expansion or contraction) on initial immersion in water.* This enabled the extent of wettability of each parchment sample to be determined.
2. *Temperature of initial shrinkage, T_i .* This is taken as the temperature step at which the measured displacement begins to decrease.
3. *Temperature of main shrinkage, T_m .* This is taken as the temperature step during which the largest percentage shrinkage occurs.
4. *Main shrinkage (%).* The amount of shrinkage that occurs within 10°C (two temperature steps) of the main shrinkage temperature.
5. *Total shrinkage (%).* This is the total overall displacement change that occurs in the sample.
6. *Temperature range of shrinkage ($T_m - T_i$).* The difference between the initial shrinkage temperature and the main shrinkage temperature ($T_m - T_i$). This range was used in preference to the whole shrinkage range, since it was not possible to accurately define a final shrinkage temperature T_f . A larger temperature range $T_m - T_i$ can be taken as an indicator of degraded collagen and thus a more aged parchment.
7. *Amount (%) of shrinkage at T_m as a fraction of the total shrinkage (ratio R),* i.e. $R = \text{main shrinkage} / \text{total shrinkage}$. In unaged parchment samples most of the shrinkage occurs within a narrow temperature region (i.e. at or close to T_m) and so this value will be high. In more aged samples the shrinkage is spread over a wider temperature range and this value will be lower.
8. *Recovery on drying.* The displacement change on removal from water and drying in air.

The results of these measurements are summarised in Table 2 for the modern and historic parchment samples. As expected, the shrinkage ratio R is much higher for the modern parchment NP7 (0.67) than for historic parchment HP28 (0.47).

3.1. Rehydration

A further measurement was made of the behaviour of a selected parchment sample (HP8) on rehydration, i.e. on re-immersion. Data are shown in Fig. 5 and Table 2. Sample HP8 was allowed to dry overnight but it was not removed from clamps before re-immersion in water and reheating. The initial displacement (expansion) was significantly larger than on the first measurement, showing greater softening and ability to stretch as a result of water absorption. Some shrinkage did occur on heating, but the overall percentage shrinkage was half of that seen during the first measurement. Additionally, there was no clearly defined temperature of maximum shrinkage. The shrinkage measured at 60°C was only 0.5% greater than that found at adjacent temperatures. This fact was reflected in the calculation of the ratio R of maximum shrinkage to total shrinkage, which is 0.27, compared to 0.53 in the original sample, and 0.67 in the unaged NP7.

The behaviour on removal from water was also different. There was an initial expansion in length, as previously observed, but this was followed by a significant contraction. It can be seen that the overall length of the sample returned to that measured at the start of the rehydration experiment (Fig. 5). This is unlike the behaviour of the samples on first heating, where the shrinkage that occurred during heating irreversibly altered the sample dimensions. This means that initial shrinkage removes the ability for the sample even on rehydration to recover its original

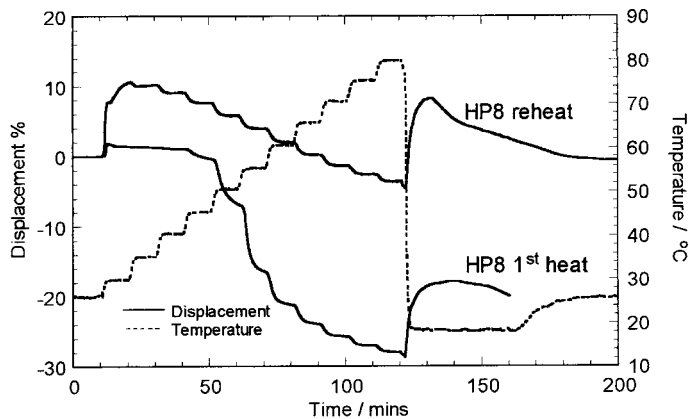

Fig. 5. Percentage displacement on immersion in water and on heating of HP8 and on re-immersion (after drying) and reheating compared with the original measurement (first heat).

state. Though this may already be known to occur, evaluation by DMTA provides direct quantification of this behaviour.

3.2. Drying profiles

The drying profiles of selected samples were measured, after a short period of immersion in water at 30°C (i.e. without heating). Results are shown in Fig. 6, for unaged parchment NP3 and historic parchment HP22. Samples were left to dry under ambient atmospheric conditions.

On immersion NP3 and HP22 responded in a different manner. NP3 contracted by 3–4% and HP22 expanded by about 4%. On removal from water

(at 25 min) NP3 was left to dry. No change was observed in its displacement until at 70 min when it started to expand by a small amount before shrinking by 9.6%. HP22, on the other hand, just before 70 min did not expand but immediately started to shrink. The amount of shrinkage was less (4.7%) and the rate of shrinking, as measured by the downward slopes of the curves, was slower than in the modern parchment.

4. Conclusions

The behaviour of leather and parchment samples under uniaxial loading when immersed in water and heated through the shrinkage temperature has been evaluated. The amount of shrinkage in terms of percentage displacement of the sample has been measured. Differences between modern and historic samples have been observed in terms of the rate of shrinkage and the overall temperature range over which it occurs. Parameters have been identified which quantify the behaviour on wetting the samples, during shrinkage and on drying. From these parameters it was possible to compare the hydrothermal stability of the samples, and the degree of their deterioration. These can provide markers for the physicochemical state of the materials. Both the unaged parchment and unaged leather samples showed a narrow, well defined temperature range across which shrinkage occurred, in the region of 65–70°C. The aged parchment (HP28), however, began to shrink as

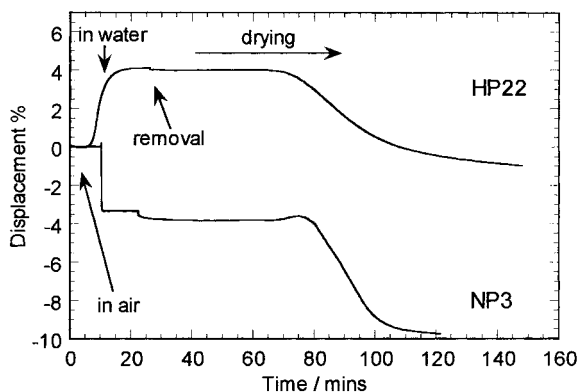

Fig. 6. Percentage displacement on immersion on water and on drying of unaged (NP3) and historic (HP22) parchments.

soon as it was immersed in water at 30°C, and this process continued gradually as it was heated.

Acknowledgements

We would like to thank Dr. René Larsen (Royal Academy of Fine Arts, School of Conservation, Copenhagen, DK) for supplying the parchment samples, and Christopher Calnan (National Trust, England) for the leather samples. The parchment project was partially supported by an EU grant (Standards Measurement and Testing SMT4-CT96-2106). We would also like to thank Dr. Roger Ibbett (Tencel Ltd within the ACORDIS Group) for a collaborative grant for the modification of the DMTA analyser.

References

- [1] M. Odlyha, G.M. Foster, N.S. Cohen, R. Larsen, *J. Therm. Anal. Cal.* 59 (2000) 587–600.
- [2] R. Larsen (Ed.), *Micromethods for the Analysis of Parchments*, EU Standards Measurement and Testing, SMT4-CT96-2106, School of Conservation, Copenhagen.
- [3] R. Larsen, *Thermochim. Acta* 360 (2) (2000), this proceeding.
- [4] C. Chahine, *Thermochim. Acta* 360 (2) (2000), this proceeding.
- [5] G.M. Foster, R. Ibbett, M. Odlyha, Birkbeck College, London, and Courtauld Textiles, Coventry, UK, Internal Report.
- [6] T.J. Wess, J.P. Orgel, *Thermochim. Acta*, 360 (2) (2000), this proceeding.
- [7] J.M.G. Cowie, *Polymers: Chemistry and Physics of Modern Materials*, Intertext, London, 1973, 232 pp.