



ELSEVIER

Thermochimica Acta 340–341 (1999) 105–116

thermochimica  
acta

www.elsevier.com/locate/tca

# Thermal analysis under quasi-isothermal–quasi-isobaric conditions

F. Paulik

*Institute for General and Analytical Chemistry, Technical University of Budapest,  
H-1521 Budapest, Hungary*

Accepted 6 August 1999

## Abstract

This paper summarizes measuring principles and results of the quasi-isothermal, quasi-isobaric measuring techniques, i.e. thermogravimetry (Q-TG), differential thermal analysis (Q-DTA), dynamic differential calorimetry (Q-DDC), differential scanning calorimetry (Q-DSC), thermo-dilatometry (Q-TD), evolved gas analysis (Q-EGA), and micro-distillation under quasi-isothermal, quasi-isobaric conditions. © 1999 Elsevier Science B.V. All rights reserved.

*Keywords:* Quasi-isothermal; Quasi-isobaric; Thermogravimetry

## 1. Introduction

It is often emphasized that the characteristic properties of materials can be determined with the help of conventional thermoanalytical equipment with greater errors than by physico–chemical measuring techniques.

For instance, as Fig. 1a demonstrates, the thermocouple of the DTA apparatus measures the actual temperatures of the sample with an accuracy greater by many orders of magnitude than that of the transformation temperature of the reaction determined on the basis of DTA curves. Namely, due to the non-isothermal heating program the transformation does not take place at the determined temperature, but over a broad temperature interval. Furthermore, as Fig. 1a shows, due to differences in the experimental conditions, the transformation processes may be shifted causing further errors.

Let us take another example. The balance part of the thermobalance similarly measures the actual weight of

the sample with an accuracy length several orders of magnitude higher than the weight change can be determined on the basis of a TG curve in the case of overlapping reactions (Fig. 1b).

From this point of view a significant change occurred in the 1960's in the development of thermoanalytical techniques and devices. A lively research activity began. The researchers wanted to solve these problems by introducing new measuring techniques such as:

- derivative thermogravimetric analysis;
- simultaneous thermoanalytical methods;
- parallel application of various complementary examinations;
- differential scanning calorimetry;
- examinations in vacuum or under high pressure;
- new micro methods.

In this research work the thermoanalytical group of the Institute for General and Analytical Chemistry at the Technical University of Budapest also took part by

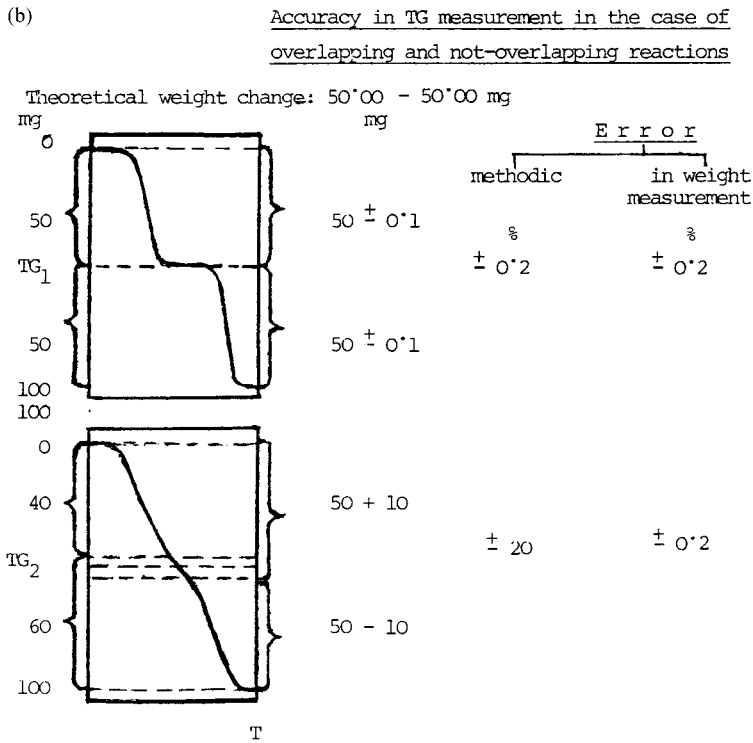
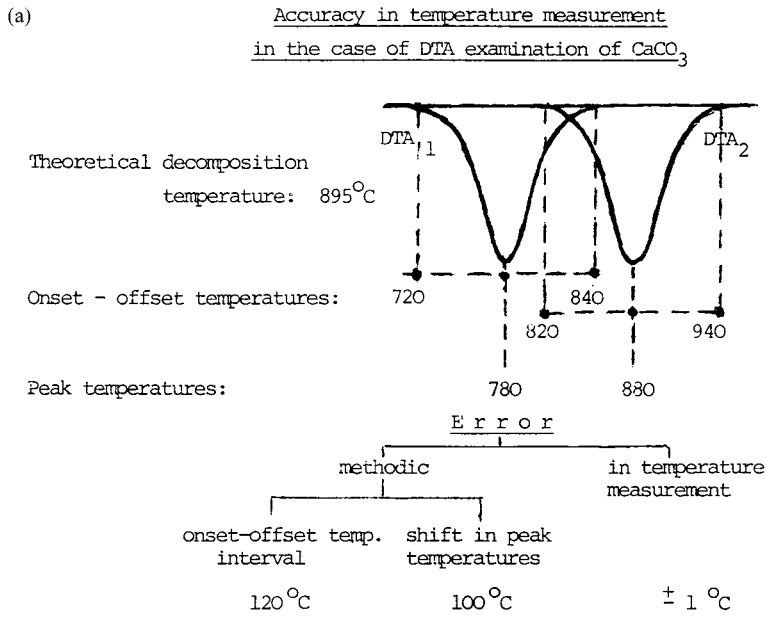

Fig. 1. Accuracy of classical methods.

developing first derivative thermogravimetry (DTG) [1–4] and later simultaneous TG, DTG, DTA methods [3–6]. Both of these techniques were realized in an instrument called the Derivatograph [3–9] produced by the Hungarian Optical Works, Budapest, for nearly 40 years [9]. Recently this plant has been closed.

## 2. Quasi-static thermal analysis

In order to eliminate the errors associated with non-isothermal examinations, as illustrated in Fig. 1, some thermoanalysts looked for the introduction of new principles, that were totally different from the earlier ones and hence elaborated the quasi-static measuring technique.

As Table 1 shows, the research group of the Technical University of Budapest elaborated in 1962 a method, claimed to be the first in this field, suitable for carrying out thermogravimetric measurements under quasi-isothermal–quasi-isobaric conditions [3,4,12,16,23]. The present paper summarizes the results obtained by application of this technique.

Independently of this initiative, in France 1964, Rouquerol [13] published a related method for the recording of temperature changes due to the reactions (Table 1). In this case the signal from the rate of evolution of the gaseous products served as the heating control. This technique was further recommended in 1969 for tracing TG curves [15], under the name

“constant rate controlled thermal analysis”, in brief CRTA (Table 1).

Later, other similar, but not identical methods [23] were also elaborated (Table 1). Therefore, it would be advisable to recommend that a collective designation, such as “quasi-static” or “transformation governed” thermal analysis, be used independent of the various authors and methods as already proposed [23]. In this case each author could use his own designation characteristic of the principle pertaining to his method.

## 3. Thermogravimetric investigations under quasi-isothermal–quasi-isobaric conditions (Q-TG)

In an ideal case, a chemical reaction leading to equilibrium should take place at a defined temperature in a quasi-isothermal manner, as illustrated by curves 1–4 in Fig. 2. Chemical reactions under non-isothermal heating conditions, however, last longer and can actually be extended over a temperature range of several hundred degrees, as shown by curves 5–8 in Fig. 2. It has been established that heat and gas transport processes are primarily responsible for the displacement of the curves [3,4,23,24,30].

A strictly causal relationship exists between the ventilation conditions in the interior of the sample, in the case of reactions leading to equilibrium, i.e. variation in the partial pressure of the gaseous decomposition product and the transformation temperatures.

Table 1  
Quasi-static measuring techniques

	Authors	Measured variables	Heating control by the signal	Patent applied or paper appeared	Reference
1	L. Erdey, F. Paulik, J. Paulik F. Paulik, J. Paulik, L. Erdey F. Paulik, J. Paulik	TG	$dm/dt$	1962 1964 1971	[10] [11] [12]
2	J. Rouquerol	T	$dp/dt$	1964	[13]
3	C.M. Bean, R.H. Oliver	T	$\Delta T$	1964	[14]
4	J. Rouquerol	TG	$dp/dt$	1969	[15]
5	F. Paulik, J. Paulik	TG, DTG, DTA	$dm/dt$	1973	[16]
6	F. Paulik, J. Paulik,	TG, EGA	$dm/dt$	1973	[17]
7	J. Paulik, F. Paulik	TD	$dI/dt$	1973	[18]
8	O.T. Sorensen	TG	$T_1, T_2, \dots, T_n$	1978	[19]
9	O.T. Sorensen	TD	$T_1, T_2, \dots, T_n$	1980	[20]
10	J. Paulik, F. Paulik, M. Arnold F. Paulik	T	$\Delta T$ $d\Delta T/dt$	1985 1995	[21] [3]
11	F. Paulik, E. Bessenyei-Paulik, K. Walther-Paulik			1997	[22]

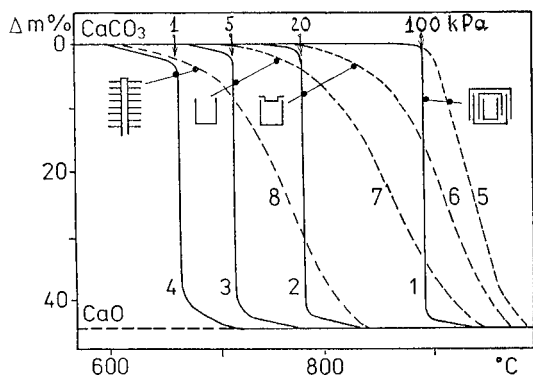

Fig. 2. Decomposition of calcium carbonate under different conditions. Curves 1–4 recorded under quasi-isothermal-quasi-isobaric, curves 5–8 under non-isothermal conditions using different types of sample holders.

Therefore, because of the various conditions of ventilation offered by the different sample holders, the transformation temperatures also changes proportionally [4]. This is illustrated by the double series of curves shown in Fig. 2, which were recorded using a multi-plate sample holder [3,4,23,25,26], a crucible with a large surface, both covered and uncovered, and also with the so-called labyrinth crucible (see Fig. 3)

which ensures a self-generated atmosphere [3,4,16, 23,27–29].

Fig. 4 illustrates the construction of equipment [3,4,10,12,23] i.e. suitable for carrying out these kinds of examinations. The heating controller (13) of the thermobalance increases the temperature of the sample, labelled (1), i.e. is placed in the sample holder (2) in the conventional way (e.g. at  $3^{\circ}\text{C min}^{-1}$ ) as long as the weight of the sample is constant. As soon as the weight change begins and reaches a given rate, the voltage of the DTG signal produced by the derivative system (7,8) reaches a given limiting value and a control system (12) immediately reduces by means of the heating controller (13) the heating voltage. Thereupon, the temperature of the sample immediately decreases, and so too does the rate of the decomposition. The DTG signal decreases below the limiting voltage and the controlling mechanism brings the heating voltage back to its earlier value. This controlling cycle lasts for only a few seconds and is repeated over and over again until the end of the transformation. Thereafter, until the beginning of the next reaction, the heating controller again increases the temperature in a non-isothermal way. Using this technique, the transformation rate can move between

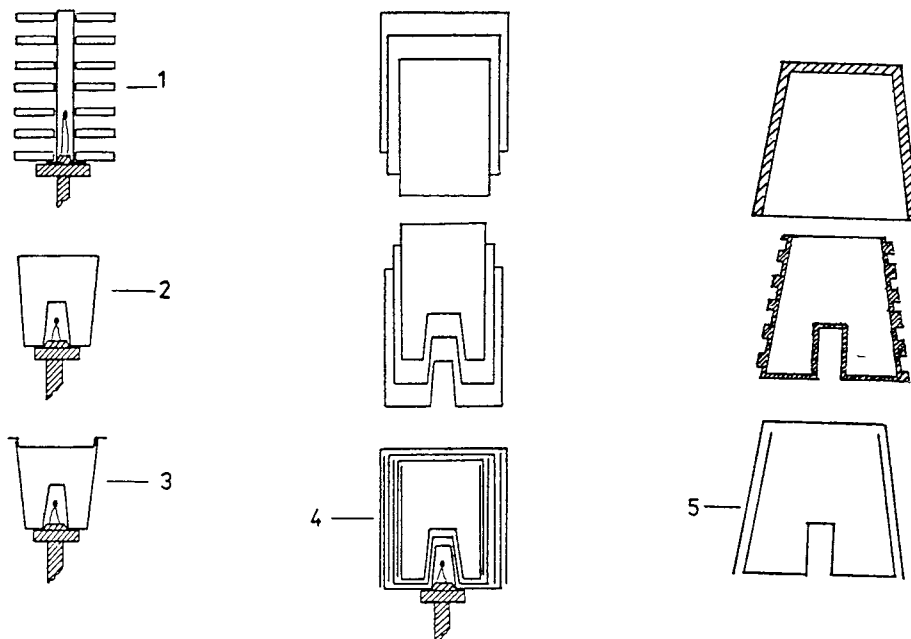

Fig. 3. Sample holders (1) multi-plate sample holder (2) uncovered (3) covered (4) conical (5) labyrinth crucible.

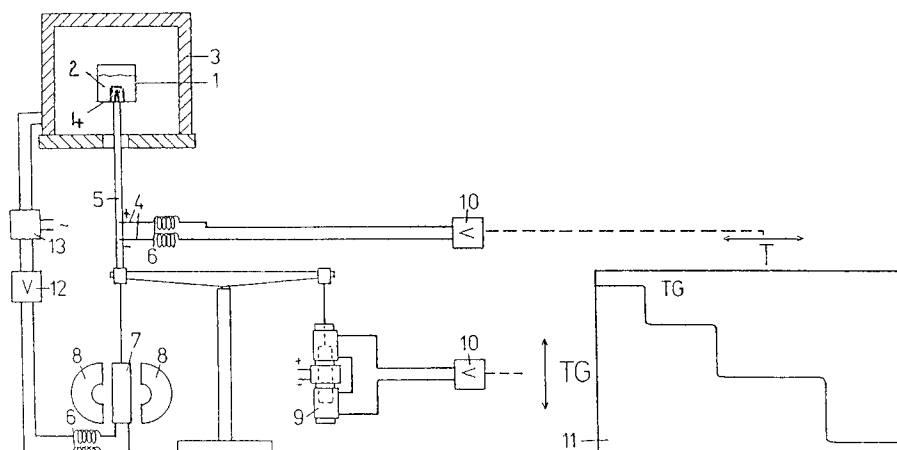

Fig. 4. Derivatograph for Q-TG studies under quasi-isothermal–quasi-isobaric conditions. (1) Sample (2) crucible (3) furnace (4) thermocouple (5) corundum tube (6) flexible conductor (7) coil (8) magnet (9) differential transformer (10) recorder (11) chart (12) sensor controller (13) heating controller.

0, 1 and  $1 \text{ mg min}^{-1}$  if the total weight change is 100 mg. Of course, nowadays this old-fashioned electronic control system is not used anymore, but is replaced by a computer and suitable software.

This method can be summarized as follows. The heating control system automatically establishes between the sample and the furnace a temperature difference that is necessary, so that the transformation takes place at a strictly constant and preselected, exceedingly low rate, slower by orders of magnitude than reactions studied by conventional non-isothermal heating methods.

The heating controller works independently whether the transformation is endothermic or exothermic. The difference between the two cases is, that in endothermic transformations the temperature of the furnace is automatically kept higher, while in exothermic reactions the furnace temperature is lower than the sample temperature [3].

In order to prove that with the use of this control system, the reactions take place at a preselected rate, the decomposition of nitro-cellulose was recorded. Curves 1, 3 and 5 in Fig. 5 were obtained under conventional conditions, whereas curves 2, 4 and 6 were obtained using the quasi-isothermal heating technique. The substance was spread out in a thin film on the big surface of the multi-plate sample holder. When the temperature was increased at a rate of  $3^\circ\text{C min}^{-1}$ , the decomposition proceeded in an

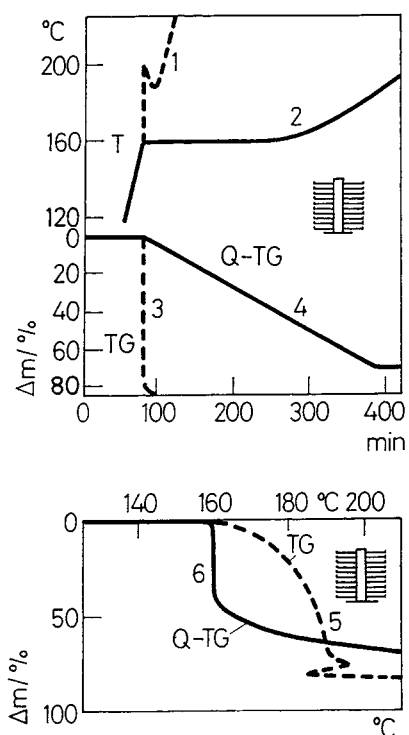

Fig. 5. Decomposition of nitrocellulose curves 1, 3, 5 obtained under conventional, curves 2, 4, 6 under quasi-isothermal conditions.

explosive manner, as curves 1 and 3 show. In contrast, when the quasi-isothermal heating program was used, the decomposition took place according to curve 4,

very slowly, taking 300 min for completion and the temperature remained constant, at least at the beginning, as shown by curve 6 [3,31].

Returning now to the particular course of curves 1–4 in Fig. 2, the following factors must be considered. In the case of reactions leading to equilibrium, the spontaneous stabilization of the temperature automatically ensures the constancy of the gas formation. Therefore, in the case of the four types of sample holders, the partial pressure of the gaseous products (ca. 1, 5, 20 and 100 kPa) and the corresponding sample temperatures (ca. 670°C, 710°C, 780°C and 895°C) set at constant values established by the correlation between the decomposition pressure and the temperature [4] and then remain constant up to the end of the transformation as indicated in curves 1–4 [3,4,16,23,24,30].

The question arises whether this measuring technique does approach better the more demanding requirements of physical chemists? It does, if the labyrinth crucible is used in the examinations. The construction of this kind of crucible is shown in Fig. 3 in two versions (4,5). From these crucibles, the air originally present is immediately expelled by the gaseous reaction products and a pure self-generated atmosphere is formed [3,4,16,23,24].

The decomposition temperature of calcium carbonate was calculated to be 897°C from thermodynamic data. The mean of 20 sets of literature data measured by physico-chemical methods gives this temperature as 895°C. In the case of curve 1 in Fig. 2 the decomposition took place at 892°C, i.e. close to the normal decomposition temperature associated with a pressure of 100 kPa of carbon dioxide. The temperature of the sample did not vary by more than  $\pm 0.5$ –1°C. Therefore, the reaction took place under near ideal circumstances, i.e. quasi-isothermal–quasi-isobaric conditions approached the physico-chemical requirements [3,4,16,23,30]. So, in this way unknown transformation temperature can be determined with high accuracy.

But the real value of the technique manifests itself when the aim is to determine the kinetics and mechanism of thermal reactions, i.e., what partial processes are involved in the reactions being examined. These partial processes generally remain hidden, observed by far stronger heat and gas transport processes that occur when they are investigated using conventional

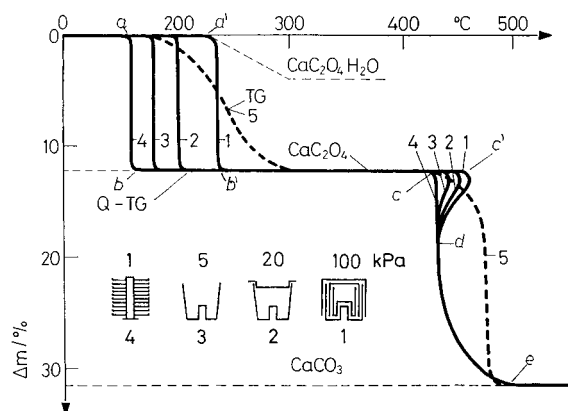

Fig. 6. Decomposition of calcium oxalate monohydrate curves 1–4 recorded under quasi-isothermal–quasi-isobaric, curve 5 under non-isothermal conditions using different types of sample holders.

methods [3,4,16,30]. This can be shown by the following three practical examples.

Curve 5 in Fig. 6 shows the thermal decomposition of calcium oxalate monohydrate obtained conventional TG. From this curve it can be seen that the decomposition took place in two steps. The sample first lost water and thereafter carbon monoxide leading to the formation of calcium carbonate. Curves 1–4 were obtained under quasi-isothermal conditions by using four different sample holders and provide much more information. It can be stated that the dehydration led to equilibrium. This is proved by the fact that the water loss (a–b) took place in an isothermal way and that in the four different sample holders, the decomposition of the sample took place at four different temperatures.

In contrast, the course of the second section of the curves (c–e), illustrating the decomposition of the anhydrous calcium oxalate, is not isothermal. But the course of the curves traced by using the four different types of sample holders became congruent, so this process can be described as an irreversible process.

The shape of the Q-TG curves may also be influenced by nuclei formation. The decomposition of the anhydrous calcium oxalate provides such an example. In the initial part of the second step, a beak-like shaped formation (c'–d) can be observed which refers to the transitional overheating of the sample. The explanation of this may be, that the first nuclei are always

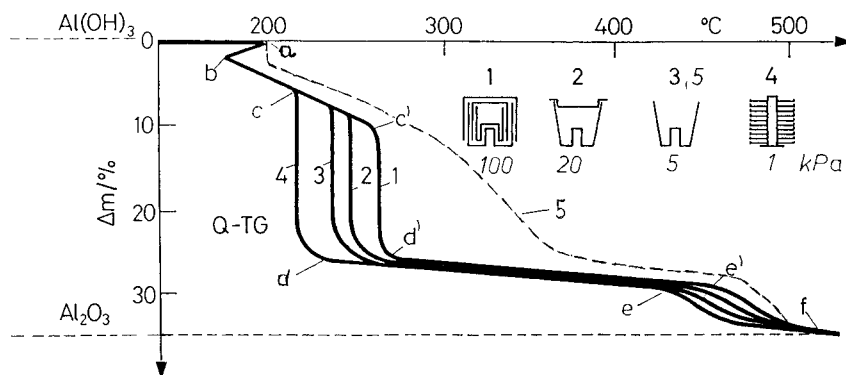

Fig. 7. Decomposition of gibbsite curves 1–4 recorded under quasi-isothermal–quasi-isobaric, curve 5 under non-isothermal conditions using different type of sample holders.

formed with difficulty and at a higher temperature than expected. However, when a sufficient nuclei are formed, the heating controller automatically reduces the temperature to the original value of the decomposition temperature (d).

It can also be observed that the extent of the over-heating depends on the type of sample holder used. It was highest in the case of the labyrinth crucible, and lowest in the case of the multi-plate sample holder. This means, that the temperature shift was proportional to the concentration of the gaseous product. The first nuclei always come into existence on the most active sites of the crystal surface. It can be supposed that in the present case these molecules blocked the active sites [3,4,23].

Curves 1–4 in Fig. 7 show the thermal decomposition of gibbsite,  $\text{Al}(\text{OH})_3$ , under quasi-isothermal heating conditions examined by applying four different sample holders, while curve 5 was obtained in the conventional way. The interpretation of this latter curve would be rather difficult, but not so that of the former curves [3,32].

The beak-like shape at the beginning of curves 1–4 indicates that the decomposition was initiated by nuclei formation (a–b). Thereafter, independent of which of the four different types of small holders was used, the Q-TG curves became congruent (b–c') and the temperature increased in the range 180–250°C. Accordingly, this part of the decomposition was irreversible. Meanwhile, under the evolution of water  $\alpha$ -boehmite was formed, which decomposed much later at about 500°C (e–f) to form  $\gamma$ -alumina.

After this, another type of reaction began (c–d) in the course of which the remaining gibbsite directly decomposed to  $\chi$ -alumina and water. This reaction was already isothermal and led to equilibrium.

From the shape of the curves it also turned out, that here it was also possible to study a seldom occurring type of reaction, the so-called competitive reactions. The first reaction, i.e. the boehmite formation, immediately stopped (c,c') when the second one, i.e. the formation of  $\chi$ -alumina started. This is due to the fact that the second isothermal process (c–d, c'–d') could proceed even when the temperature of the furnace was constant, but continuously a little higher than the transformation temperature, while the first non-isothermal process (b–c, b–c'), due to its nature, could not do so without a continuous and necessarily increasing temperature. It was also proved by X-ray investigations, that the decomposition of gibbsite took place in the way described above [3,33].

The decomposition of magnesium ammonium phosphate monohydrate can be classified as a reaction leading to equilibrium in spite of its non-isothermal course. Fig. 8 shows the conventional TG curve (curve 5) and the Q-TG curves obtained using quasi-isothermal heating technique (curves 1–4) [3,34]. The sections of the curves (a–b) between 150°C and 350°C did not coincide, but followed one another as usually characteristic of equilibrium reactions. Furthermore, a close correlation was observed between the sequence of curves 1–4 and the partial pressure of water vapour within the sample. Since this decomposition process leading to equilibrium did not take place in an iso-

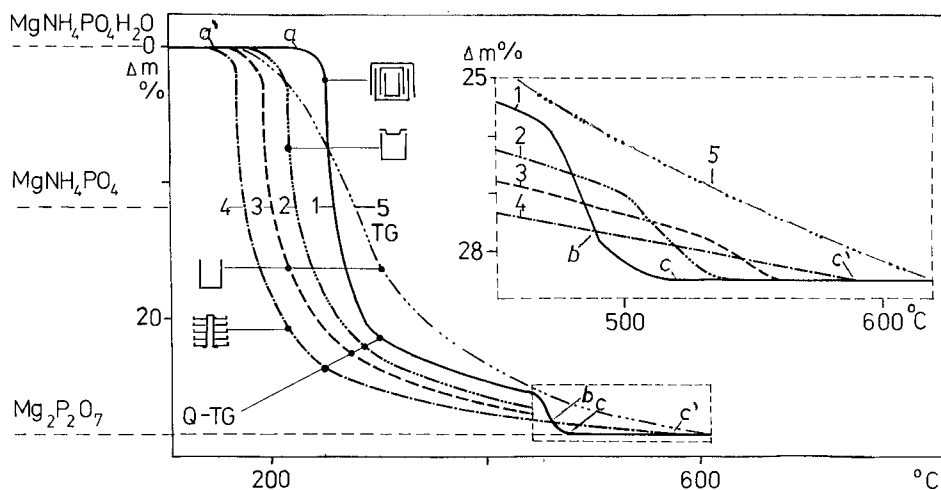

Fig. 8. Decomposition of magnesium ammonium phosphate monohydrate curves 1–4 recorded under quasi-isothermal–quasi-isobaric, curve 5 under non-isothermal conditions using different type of sample holders.

thermal way, the conclusion is that the new solid phase was not porous and the gaseous product that formed could only diffuse through the gradually increasing compact layer with more and more difficulty.

The sequence of curves 1–4 was reversed between 450°C and 500°C, forming a cross-over point (b) and in an unexpected way the decomposition in the labyrinth crucible ( $p_{\text{H}_2\text{O}}=100$  kPa) ended at a temperature about 100°C lower (c) than in the multi-plate sample holder ( $p_{\text{H}_2\text{O}}=1$  kPa) ( $c'$ ). This observation can only be explained by the favourable effect that the water vapour atmosphere exerted upon the porosity of the new phase. In similar way many other metal ammonium phosphate monohydrates were found to decompose [35], e.g.  $\text{MnNH}_4\text{PO}_4 \cdot \text{H}_2\text{O}$  [3,30].

From above, it is established that in the case of non-isothermal examinations the heat and gas transport processes change the course of the observed curves to such an extent, that they become rather more characteristic of the experimental conditions than of the reactions themselves [3,4,16,23,30]. Because of this, the author and his colleagues rejected in 1971 the possible use of the non-isothermal methods to calculate kinetic parameters based on Arrhenius model from the course of the decomposition curves of inorganic compounds [12]. This view was supported by calculations based on experimental results [3,36]. They also observed that in mathematical terms the Arrhenius model is badly conditioned allowing a poor

parameter estimation [3,36,37,38]. The compensation effort reported by many thermoanalysts can be traced to this hidden defect in the Arrhenius model.

#### 4. DTA examinations under quasi-isothermal–quasi-isobaric conditions

The research group of the Technical University of Budapest in 1985 (Table 1) elaborated another version of the quasi-isothermal heating technique which can be applied to DTA or DDC (dynamic differential calorimetry) equipment [3,21]. In the course of this work the group had to solve a difficult problem. It is well known that the base line (d in Fig. 9) of the DTA curve (e) can be displaced in an uncontrollable way, in contrast to the DTG curve which in the case of the Q-TG method controls the heating rate. As Fig. 9 shows, the displacement of the DTA base line (d) can set into operation the heating control system, because it reaches level *f* although the transformation itself has not begun. This displacement can be eliminated.

The principle of the recommended technique is based on the observation, that the derivative of the DTA curve, the so-called DDTA signal (*m*) indicates the change in the rate of the transformation more sensitively than the DTA curve (*e*) shows [3,21].

The structure and the function of the new equipment based on this observation can be seen in Fig. 10. In this



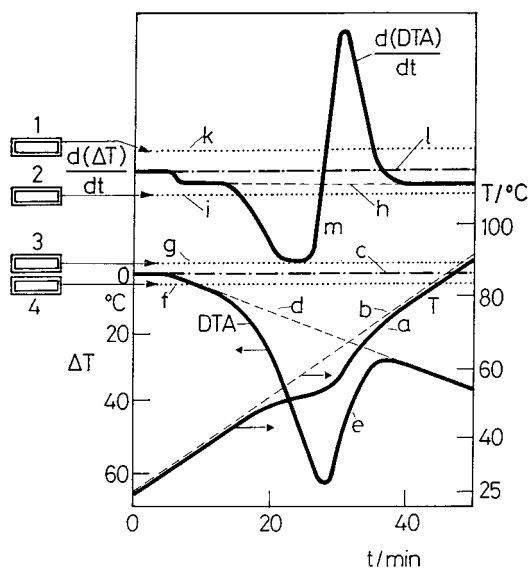

Fig. 9. Change in temperature of the sample (a) and reference material (b). Lines representing the base-line shift (d) of the DTA curve (e) with respect to the ideal base-line (c). Base-line (h) of the DDTA curve (m) when the DTA curve has a base-line shift (d). Levels (f,g,i,k) defined by the photo-electric detectors (1-4).

method, the temperature of the furnace is first raised at a heating rate of  $1-5^{\circ}\text{C min}^{-1}$ . Following this, when the derived signal (Q-DDTA) attains a preselected limiting value : (i) the light signal from the galvanometer (14) hits the signal detector (4) which is in electrical contact with the multi-function control unit (15). The latter applies a counter voltage to the Q-DTA galvanometer (12) i.e. sufficient for the light signal to return to the basic position (c) and sets the end-position switch (12) in operation, which in turn directs the heating controller (16) to start working in the quasi-isothermal mode. From this time, the heating controller adjusts the difference in temperature between the furnace and the sample necessary to ensure a preselected rate of the transformation (f). In practice the software of the computer controls the heating [3,21].

Returning to the critique of physical chemists it must be stated, that also in the case of DTA or DDC examinations a significant development can be achieved, as the following example shows [3].

Fig. 11 depicts the original records of the DTA curve of potassium perchlorate investigated by the

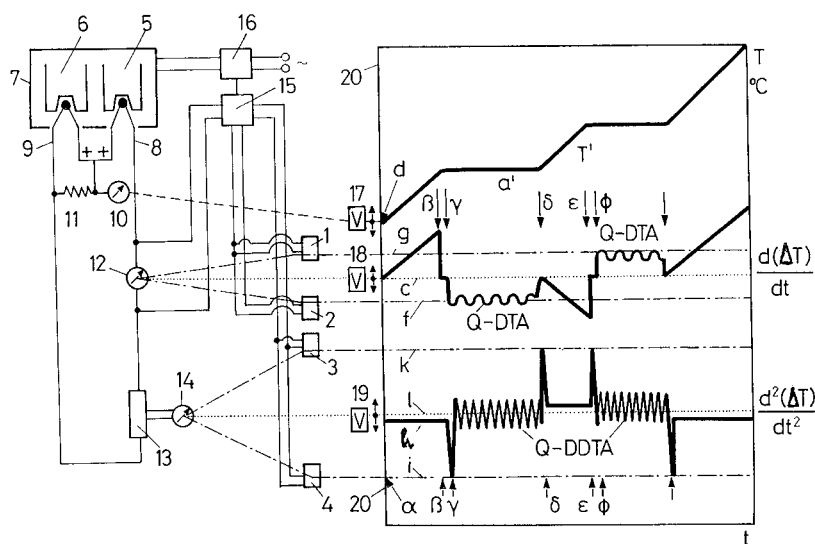

Fig. 10. DTA apparatus for studies under quasi-isothermal and quasi-isobaric conditions. Photoelectric detectors (1-4), sample 5, reference material (6), furnace (7), counter-connected thermocouples (8,9), galvanometers (10,12,14) compensating resistance (11), deriving unit (13), relay and controller system (15), heating program system (16), recorder (17-19), chart (20). Non-isothermal heating starts ( $\alpha$ ), endothermic transformation starts ( $\beta$ ), quasi-isothermal heating starts ( $\gamma$ ), and ends and non-isothermal heating starts ( $\delta$ ), exothermal transformation starts ( $\epsilon$ ), quasi-isothermal heating starts ( $\phi$ ), etc. O-line (c), and levels (f,g) of the DTA curve and original (1) and shifted O-line (h) and levels (i,k) of the Q-DTA curve.

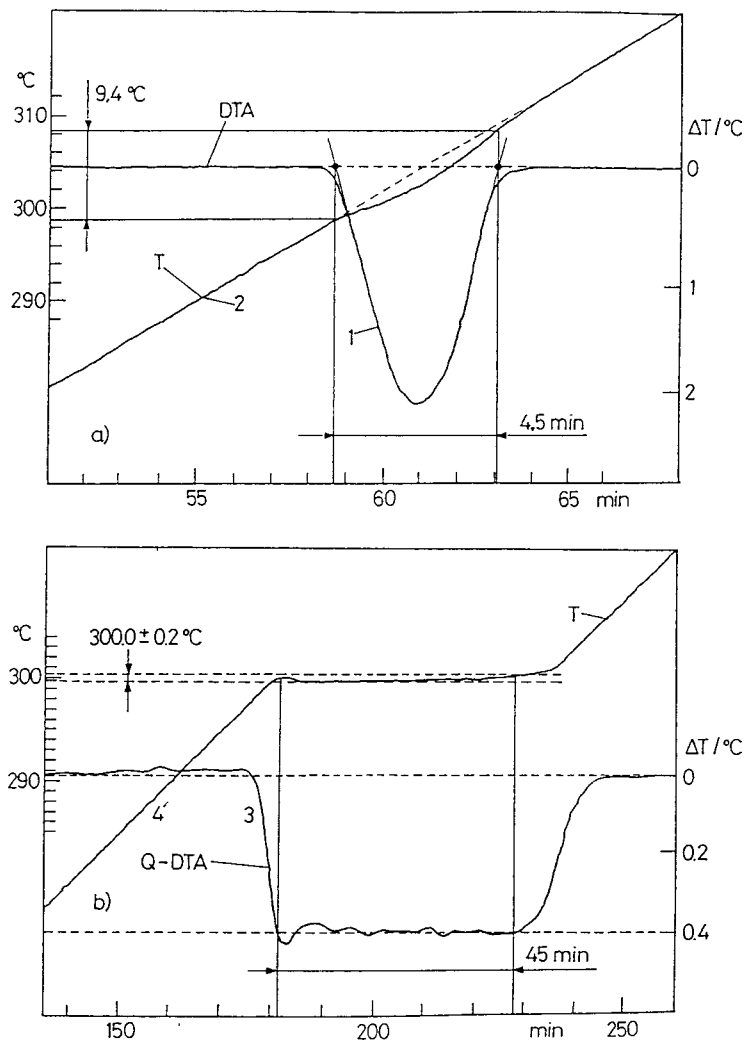

Fig. 11. Modification change of potassium perchlorate. Original record with non-isothermal (curves 1,2) and quasi-isothermal (curves 3,4) heating modes.

conventional (curves 1, 2) and the new measuring technique (curves 3, 4). According to the literature, the transformation temperature of the material is exactly  $300^\circ\text{C}$ . In the conventional DTA experiment the applied heating rate was  $2^\circ\text{C min}^{-1}$ . Curves 1 and 2 demonstrate that in this case the transformation took place in 4.5 min to proceed in a temperature interval of  $9.4^\circ\text{C}$ . In contrast in the quasi-isothermal study, as curves 3 and 4 show, the transformation took 45 min to be completed, while the temperature of the sample was stabilized at  $300 \pm 0.2^\circ\text{C}$ , in other words the sample

temperature hardly changed during the transformation.

As far as the field of application of the method is concerned, it is easy to see that it involves a multiple possibilities. Only some thermal transformations are accompanied by weight changes, while all chemical and physical transformations are accompanied by enthalpy changes. Consequently the application of this technique is unrestricted. It is sufficient to mention solid state reactions, and phase changes in multi-component solid-liquid systems [3].

#### 4.1. Q-DSC examinations

In the case of modification to the Q-DTA measuring technique, due to the double heating system, certain changes must be carried out [21]. These further increase the selectivity and resolution of the DSC curves obtained.

#### 4.2. Q-TD examinations

The diffusion processes taking place during thermogravimetric examinations are exceedingly slow and depend on temperature changes. Since the quasi-isothermal heating technique permits the transformations to take place at a very slow and constant rate, its application is also advantageous in this field [3,4,18,39].

#### 4.3. Q-EGA examinations

Evolved gas analysis (EGA) contributes to the interpretation and evaluation of simultaneously recorded curves, because it makes it possible to identify partial reactions and hence determine them separately from one another [3,4]. Experience shows that the application of the Q-TGT method [17] offers further advantages from the point of view of selectivity and resolution [23,40].

### 5. Micro-distillation technique by Q-TG method

Since the quasi-isothermal heating technique is capable of automatically stopping the temperature increase when the sample begins to boil and limits the rate of departure of the evolved vapours to a very low and constant value, the partial pressure of the vapours above the liquid situated in the labyrinth crucible attains 100 kPa immediately at the beginning of the process and remains constant at this value. Hence the Q-TG method can also be applied to micro-distillation examination [3,41].

### References

- [1] F. Paulik, J. Paulik, L. Erdey, Hung. Patent No. 144 548, 1954.
- [2] L. Erdey, F. Paulik, J. Paulik, *Nature* 174 (1955) 885.
- [3] F. Paulik, *Special Trends in Thermal Analysis*, Wiley, Chichester, 1995.
- [4] J. Paulik, F. Paulik, *Simultaneous Thermoanalytical Examinations by Means of the Derivatograph*, Elsevier, Amsterdam, 1981.
- [5] F. Paulik, J. Paulik, L. Erdey, Hung. patent No. 145 369, 1955, patents in: USA, England, Germany, France, 1956.
- [6] F. Paulik, J. Paulik, L. Erdey, *Z. Anal. Chem.* 160 (1958) 241.
- [7] F. Paulik, J. Paulik, L. Erdey, *Talanta* 13 (1966) 1405.
- [8] J. Paulik, F. Paulik, M. Arnold, *J. Thermal Anal.* 32 (1987) 301.
- [9] F. Paulik, *J. Thermal Anal.* 47 (1996) 659.
- [10] L. Erdey, F. Paulik, J. Paulik, Hung. patent No. 152 197, 1962.
- [11] F. Paulik, J. Paulik, L. Erdey, Patents in: USA, England, Germany, France, Switzerland, Austria, Italy, 1964.
- [12] F. Paulik, J. Paulik, *Anal. Chim. Acta* 56 (1971) 328.
- [13] J. Rouquerol, *Bull. Soc. Chim. Fr.* (1964) 31.
- [14] C.M. Bean, R.H. Oliver, Engl. patent No. 1 063 898, 1964.
- [15] J. Rosquerol, *Thermal Analysis, Proceedings of the Second ICTA Conference, Worchester, Academic Press, New York, 1969.*
- [16] F. Paulik, J. Paulik, *J. Thermal Anal.* 5 (1973) 253.
- [17] F. Paulik, J. Paulik, *Anal. Chim. Acta* 67 (1973) 437.
- [18] J. Paulik, F. Paulik, *Thermal Analysis, Proceedings of the Fifth ICTA Conference, Kyoto, Heyden, London, 1977, p. 75.*
- [19] O.T. Sorensen, *J. Thermal Anal.* 13 (1978) 429.
- [20] O.T. Sorensen, *Thermal Analysis, Proceedings of the Sixth ICTA Conference, Bayreuth, Birkhäuser, Basel, 1971.*
- [21] J. Paulik, F. Paulik, M. Arnold, Hung. patent No. 193 114, 1985, patents in: USA, England, Germany, France, Switzerland, 1985.
- [22] F. Paulik, E. Bassenyey-Paulik, K. Walther-Paulik, Hung. patent: applied, 1997.
- [23] F. Paulik, J. Paulik, *Thermochim. Acta* 100 (1986) 23.
- [24] F. Paulik, J. Paulik, *Thermochim. Acta* 4 (1972) 189.
- [25] F. Paulik, J. Paulik, L. Erdey, Hung. patent No. 151 783, 1963, patents in USA, England, Germany, France, Italy, Switzerland, Japan, Austria.
- [26] J. Paulik, F. Paulik, L. Erdey, *Anal. Chim. Acta* 34 (1996) 419.
- [27] F. Paulik, J. Paulik, Hung. patent No. 163 305, 1971, patents in USA, England, Germany, France, Italy, Switzerland, Austria, Japan.
- [28] F. Paulik, J. Paulik, *Anal. Chim. Acta* 60 (1972) 127.
- [29] F. Paulik, J. Paulik, *Thermochim. Acta* 4 (1972) 189.
- [30] F. Paulik, J. Paulik, *J. Thermal Anal.* 38 (1992) 197.
- [31] F. Paulik, J. Paulik, M. Arnold, *J. Thermal Anal.* 12 (1977) 383.
- [32] F. Paulik, J. Paulik, R. Naumann, K. Kähnke, D. Petzold, *Thermochim. Acta* 64 (1983) 1.
- [33] R. Naumann, K. Kähnke, J. Paulik, F. Paulik, *Thermochim. Acta* 64 (1983) 15.

- [34] F. Paulik, J. Paulik, J. Thermal Anal. 8 (1975) 557.
- [35] J. Paulik, F. Paulik, J. Thermal Anal. 8 (1975) 567.
- [36] M. Arnold, G. Veress, J. Paulik, F. Paulik, J. Thermal Anal. 17 (1979) 507.
- [37] M. Arnold, G. Veress, J. Paulik, F. Paulik, Anal. Chim. Acta 124 (1981) 341.
- [38] M. Arnold, G. Veress, J. Paulik, F. Paulik, Thermochim. Acta 52 (1982) 67.
- [39] F. Paulik, J. Paulik, J. Thermal Anal. 16 (1979) 399.
- [40] F. Paulik, J. Paulik, Anal. Chim. Acta 67 (1973) 437.
- [41] F. Paulik, S. Gál, K. Mészáros-Szécseyi, J. Thermal Anal. 42 (1994) 425.