

# Mini-bomb combustion calorimeter

An Xu-wu<sup>\*</sup>, He Jun

*Institute of Chemistry, The Chinese Academy of Sciences, Beijing 100080, PR China*

Received 2 June 1999; received in revised form 30 August 1999; accepted 24 September 1999

## Abstract

Three mini-bomb calorimeters of different types have been built with the common characteristics: 5 cm<sup>3</sup> of bomb volume, 10 mg of sample, ~420 J K<sup>-1</sup> of energy equivalent. These calorimeters can be calibrated by the electric method with the standard deviation of the mean of 0.02%. The results of burning reference material — benzoic acid (BA39i) by using the calorimeters 2 and 3 are in agreement with the recommended value, however, that by using the calorimeter 1 is 0.24% larger. A check experiment shows that the stirring effect in this calorimeter is not enough during the heating period. The energies of combustion of C<sub>60</sub> and C<sub>70</sub> have been determined by using the calorimeter 2. © 2000 Elsevier Science B.V. All rights reserved.

*Keywords:* Mini-bomb calorimeter; Electric energy calibration; Combustion energy of benzoic acid

## 1. Introduction

Combustion calorimetry is a basic method to obtain accurate thermochemical data. An experimental determination of the combustion enthalpy by traditional bomb calorimetry needs about 5–10 g of a highly pure compound (>0.999 mole fraction). For many new materials the sample in such a large quantity usually is expensive, sometimes it is not available. Therefore, the miniaturization of bomb calorimeter is imperative. However, many difficulties are caused from this miniaturization and some of them are limited by the current technique. So it gives a challenge to thermochemists. A few mini-bomb calorimeters have been reported [1–5], in which the sample quantities of each burning experiment are 5–50 mg with the standard deviation of the mean from 0.02 to 0.04%. For study-

ing the thermochemistry of fullerenes we have built three types of mini-bomb calorimeter with the following common characteristics: 5 cm<sup>3</sup> of bomb volume; 10 mg of sample; ~420 J K<sup>-1</sup> of energy equivalent. These instruments have been examined by burning the reference material — benzoic acid, and the enthalpy of combustion of C<sub>60</sub> and C<sub>70</sub> have been determined by using the calorimeter 2.

## 2. Experimental

### 2.1. Apparatus

All of the three mini-bomb calorimeters are of isoperibal and stirred-water type. They consist of thermostat, bomb, calorimeter vessel, thermistor and the automatic temperature-measuring system, heater and the measuring system for electric energy, and igniting circuit.

<sup>\*</sup> Corresponding author. Fax: 861-010-625-69564.  
E-mail address: hanbx@pplac.icas.ac.cn (A. Xu-wu)

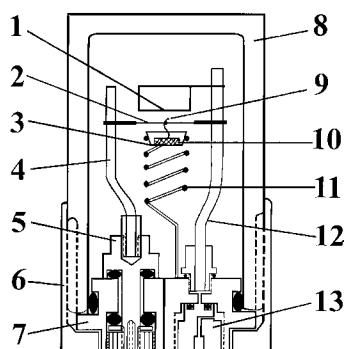

Fig. 1. Cross-section of microbomb: (1) flame baffle, (2) platinum wire for ignition, (3) crucible, (4) electrode, (5) electrode support, (6) bomb cover, (7) bomb head, (8) bomb body, (9) PPL fuse, (10) sample, (11) crucible support, (12) inlet tube, (13) valve.

The thermostat is one of LKB-8700, and its temperature can be kept at  $(25.0 \pm 0.001)^\circ\text{C}$ .

The bomb is made of stainless steel with platinum parts of inlet tube and electrode for ignition. Platinum crucible (0.1 mm in wall thickness and 85 mg in weight) is supported on a platinum spring (0.3 mm in diameter). The bomb can be filled with pure oxygen to 4 MPa on a filling apparatus. The burning of sample can reach completion under this condition. A cross-section of the bomb is illustrated in Fig. 1.

The temperature probe is a thermistor (5 or 10 k $\Omega$  at  $25^\circ\text{C}$ ), its resistance value can be measured automatically by a Datron 1061A digital multimeter with a  $6\frac{1}{2}$  digit display and a printer.

The measuring system for electric energy is that of LKB 8700, and a Keithley 191 Digital Multimeter with a  $5\frac{1}{2}$  digit display has been used instead of the original potentiometer in this system.

The heater is made of constantan wire 0.1 mm in diameter with a resistance of 50  $\Omega$ .

The vessel of calorimeter 1 is made of stainless steel, with 50 mm diameter, 67 mm length and  $\sim 100\text{ cm}^3$  internal volume. The vessel can be sealed with a viton "O" ring and mounted in the cradle under the cover of LKB 8721-4 closed bomb reaction calorimeter. It can be rotated about  $\pm 180^\circ$  to stir the bomb liquid for heat equilibrium of calorimeter contents. The mini-bomb is supported in a gimbal-like holder to keep the bomb at the center of the vessel and always in an inverse position without spilling the crucible con-

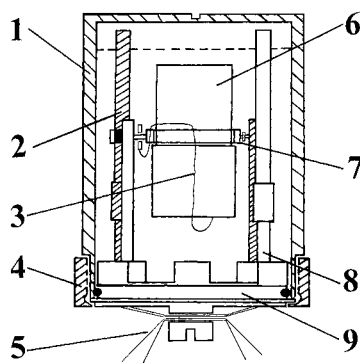

Fig. 2. Schematic diagram of the microbomb calorimeter 1 (1) vessel, (2) thermistor, (3) ignition wire, (4) ring cover, (5) electric wires, (6) bomb, (7) gimbal and support for bomb, (8) heater, (9) vessel cover.

tents. The thermistor and heater are mounted under the cover of vessel and located in both sides of bomb symmetrically. Fig. 2 is the schematic diagram of the vessel of calorimeter 1.

The vessel of calorimeter 2 is made of thin wall glass, with 54 mm diameter, 63 mm length and  $\sim 90\text{ cm}^3$  internal volume. A glass cylinder of 30 mm diameter is located in the middle of the vessel and separates it into internal and outer compartments. The bomb is placed in a holder on the bottom of the vessel and located at the center of the internal compartment. The thermistor is mounted under the upper wall of vessel and located in the outer compartment. The heater wire is wound on a Teflon tube and placed in a glass tube, which is mounted on the top of the glass cylinder. The screw propeller is located above the bomb, and stirs the water circulating between the internal and outer compartments. By using a thin wall glass tube, the calorimetric vessel is attached to the lid of the outer metal which is submerged into the thermostat. Fig. 3 is the schematic diagram of the calorimeter 2 with its vessel.

The vessel of calorimeter 3 is made of nickel-plating copper with 48 mm diameter, 66 mm long and  $\sim 90\text{ cm}^3$  internal volume. A metal cylinder of 30 mm diameter is located in the middle of the vessel and separates it into internal and outer compartments. The bomb is placed in a holder on the bottom of the vessel and located at the center of the internal compartment. The heater wire in a Teflon tube of 1 mm diameter is wound around the bomb holder. The

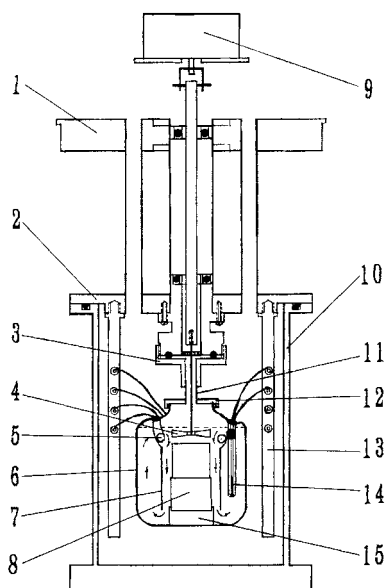

Fig. 3. Schematic diagram of the microbomb calorimeter 2: (1) thermostat cover, (2) jacket cover, (3) connector, (4) stirrer, (5) heater, (6) calorimeter vessel, (7) cylinder for stirring, (8) bomb, (9) motor, (10) jacket, (11) glass tube, (12) cover of calorimeter vessel, (13) terminals, (14) thermistor, (15) bomb support.

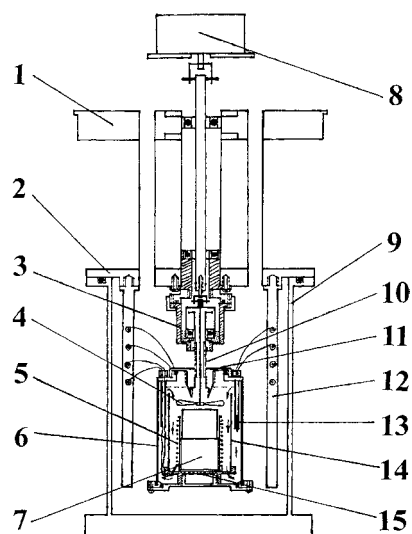

Fig. 4. Schematic diagram of the microbomb calorimeter 3: (1) thermostat cover, (2) jacket cover, (3) connector, (4) stirrer, (5) heater, (6) calorimeter vessel, (7) bomb, (8) motor, (9) jacket, (10) nylon tube, (11) cover of calorimeter vessel, (12) terminals, (13) thermistor, (14) cylinder for stirring, (15) bomb support.

thermistor is mounted in the outer compartment. The screw propeller is located above the bomb, and stirs the water circulating between the internal and outer compartments. By using a thin wall nylon tube, the calorimetric vessel is attached to the lid of the outer metal which is submerged into the thermostat. Fig. 4 is the schematic diagram of the calorimeter 3 with its vessel.

The electric current for ignition from a capacitor (18 V, 3000  $\mu$ F) fuses a 0.04 mm platinum wire and ignites a piece of polypropylene thread and then the sample. The electric energy can be measured from the voltages before and after ignition.

## 2.2. Calorimetric experiment

The calibration and combustion experiments were carried out according to an analogous procedure [6].

The sample was pressed into pellets 3 mm diameter and about 10 mg weight. A pellet was placed in a container of aluminum foil and weighed on a micro-

balance which had been calibrated by a certified platinum weight of 10 mg in the weighing range of 20 mg with an accuracy of 1  $\mu$ g. Each weighing was repeated at least 3–5 times, and the mean value was used. The pellet was transferred into the platinum crucible, and its weight was obtained from the difference between the weights of loaded and empty container. A piece of polypropylene thread was weighed and used as the fuse for ignition. All the weights were corrected to the mass in vacuo.

The internal platinum parts in the bomb were heated over a flame to burn out any combustible material probably as a result of contamination. The crucible with the sample pellet was placed on the crucible holder. A platinum wire of 0.04 mm diameter with the fuse was connected on the electrodes and one end of the fuse was in contact with the pellet. 0.01 g water was placed in the bomb and the bomb was sealed. After displacing the air three times by using 2 MPa pure oxygen, the bomb was filled with oxygen to 4 MPa, and then it was weighed to calculate the quantity of oxygen and to test for leaks. The calorimeter vessel with the bomb at its holder was filled with water and the total weight of them was adjusted to a

Table 1  
Some characteristics of the calorimeters (1, 2, 3)

Calorimeter	1	2	3
Cooling constant ( $\text{min}^{-1}$ )	0.0098	0.0066	0.0068
Stirring heat ( $\text{K min}^{-1}$ )	0.00027	0.0001	0.0002
Adiabatic, $\Delta T$ (K)	0.65	0.71	0.71
Heating power of thermistor ( $\text{K min}^{-1}$ )	0.00053	0.00002	0.00002
Calibrating power (W)	0.5	0.5	0.5
Heating period (s)	600	600	600
Energy equivalent ( $\text{J K}^{-1}$ )	$456.20 \pm 0.05$	$420.81 \pm 0.08$	$419.29 \pm 0.08$
Mass of benzoic acid (mg)	10	10	10
$-\Delta_c u^0$ (BA39i) ( $\text{J g}^{-1}$ )	$26498 \pm 12$	$26413.2 \pm 4.4$	$26414.2 \pm 6.2$

standard value. The jacket with the calorimeter vessel at its place was sealed and put into the thermostat. The stirrer was started. The digital voltmeter for temperature measurement was calibrated against a 10 k $\Omega$  standard resistor. The calorimeter was heated up or cooled down to 23.7°C. The system was stood by for 30 min for establishing a steady condition.

The calorimeter was firstly calibrated by the electric method. The digital multimeter for electric energy measurement was checked against a precise battery of six saturated standard cells in 1 and 10 V measuring ranges, respectively. The heating power (0.5 W) was calibrated and the heating period (600 s) was set. The observations of temperature of calorimeter were divided into the initial (20 min), reaction (20 min) and final (20 min) periods. At the end of the initial period, the heating power was turned on and a constant current of 100 mA was supplied into the heater circuit. The potential drops across the heater (with its leads) and a certified standard resistor of 10  $\Omega$  connected in series with the heater was recorded for calculating the heating current and the heater resistance.

After calibration the system was cooled to starting temperature and stood by for 30 min, then the combustion experiment was started, in which the initial, reaction, and final periods were 20, 20, and 20 min, respectively. At the end of the initial period, a current from the capacitor circuit was used for ignition. The voltage change on the capacitor was recorded for calculating the ignition energy. After the observations of temperature were made, the interior of the bomb was examined for the soot and the solution in the bomb was examined for the formation of nitric acid.

### 3. Results

A computer program was used for the calculation of the temperature and the adiabatic temperature rise ( $\Delta T_{\text{ad}}$ ) of calorimeter. Firstly, the resistance values of thermistor were converted into the temperature values. The data of initial and final periods were fitted with a linear function, respectively, then the Newton cooling constant of calorimeter,  $k$ , was calculated. Keeping the  $k$  constant, the data of initial and final periods were fitted again with an exponential function. The differences between experimental and fitted temperatures during the initial and final periods were usually less than 0.0001 and 0.00005 K, respectively. Finally, the  $\Delta T_{\text{ad}}$  was calculated. Extending the main period, the calculated adiabatic  $\Delta T_{\text{ad}}$  did not significantly change after 2 min from the end of electric heating or 5 min from ignition. The energy equivalent of initial system,  $\epsilon^i$ , was obtained from the added electric energy  $Q_e$  and  $\Delta T_{\text{ad}}$ , i.e.  $\epsilon^i = Q_e / \Delta T_{\text{ad}}$ . The added electric energy in the calibration experiment was to be corrected for the resistance change during

Table 2  
Electric calibration of energy equivalent of calorimeters (1, 2, 3)

	$\epsilon^{\text{si}}$ (1) ( $\text{J K}^{-1}$ )	$\epsilon^{\text{si}}$ (2) ( $\text{J K}^{-1}$ )	$\epsilon^{\text{si}}$ (3) ( $\text{J K}^{-1}$ )
	456.411	420.848	419.179
	456.124	420.973	419.297
	456.199	420.908	419.287
	456.267	420.480	419.485
	456.196	420.819	418.897
	456.033		419.520
$\langle \epsilon^{\text{si}} \rangle$ ( $\text{J K}^{-1}$ )	456.205	420.806	419.290
$s$ ( $\text{J K}^{-1}$ )	$\pm 0.052$	$\pm 0.086$	$\pm 0.083$

Table 3  
Experimental results of standard molar energies of combustion by the calorimeters (1,2,3)

	$-\Delta_c U_m^0(\text{BA})(1)$ (kJ mol <sup>-1</sup> )	$-\Delta_c U_m^0(\text{BA})(2)$ (kJ mol <sup>-1</sup> )	$-\Delta_c U_m^0(\text{BA})(3)$ (kJ mol <sup>-1</sup> )	$-\Delta_c U_m^0(\text{C}_{60}, \text{c})(2)$ (kJ mol <sup>-1</sup> )	$-\Delta_c U_m^0(\text{C}_{70}, \text{c})(2)$ (kJ mol <sup>-1</sup> )
	3234.2	3227.50	3224.50	25969.4	29937.7
	3230.5	3224.28	3227.68	25945.5	29979.1
	3237.4	3225.51	3224.05	25945.5	29951.3
	3232.0	3226.02	3227.96	25919.0	29974.9
	3229.3	3224.99	3223.91	25927.9	29937.6
	3238.3		3226.51		
$\langle -\Delta_c U_m^0 \rangle$ (kJ mol <sup>-1</sup> )	3233.6	3225.66	3225.76	25941.5	29956.1
$s$ (J K <sup>-1</sup> )	±1.5	±0.54	±0.75	±8.7	±8.9

the first seconds of heating; it is decreased from  $-0.011\%$  in the calorimeter 2 to  $0.002\%$  in the calorimeter 3. The standard energy equivalent of initial system with empty bomb was given by  $\varepsilon^{\text{si}} = \varepsilon^{\text{i}} - \Delta \varepsilon^{\text{i}}$  (cont), where  $\Delta \varepsilon^{\text{i}}$  (cont) was the total heat capacity of the changeable parts in the bomb, which contained sample, bomb-liquid, oxygen, crucible, etc. Some characteristics of the three calorimeters are listed in Table 1. The derived energy equivalents of the three calorimeters are listed in Table 2. The standard deviation of the mean of measuring the energy equivalent of the three calorimeters are all about  $(0.01-0.02)\%$ .

The reference material of benzoic acid was used for examining the accuracy of measurement. The standard combustion energy of BA39i was calculated by a computer program [6]. The mean values from 5 to 6 burning experiments are listed in Table 3. It can be seen that the results of calorimeter 2 and 3 are in agreement with each other and with the recommended value  $(26\,414 \pm 1.3) \text{ J g}^{-1}$ , respectively, in the standard state condition, and the result of the calorimeter 1 is larger. A check experiment shows that the stirring effect in the calorimeter 1 is not enough during heating period, and the temperature on the side of thermometer is lower than that on the side of heater. It is necessary to improve the heater of calorimeter 1 so that the heating energy is well distributed over the calorimeter. In comparison with calorimeter 2, the calorimeter 3 is favorable for the following advantages: (1) lower cooling constant, (2) better heat

conductivity of copper vessel than that of glass one, (3) easier to be manufactured, (4) less change in the resistance value of heater during the first few seconds of heating, and (5) more similarity in the heat developing between from the bomb in a combustion experiment and from the heater in a calibration experiment by arranging the heater around the bomb in calorimeter 3.

In addition, the standard molar energies of combustion of C<sub>60</sub> and C<sub>70</sub> have also been determined by using the calorimeter 2 and are listed in Table 3.

### Acknowledgements

This Research Project (No. 29773053) was supported by NSFC.

### References

- [1] M. Månsson, *J. Chem. Thermodyn.* 5 (1973) 721.
- [2] H.P. Diogo, M.E. Minas da Piedade, T.J.S. Dennis, J.P. Hare, H.W. Kroto, R. Taylor, D.R.M. Walton, *J. Chem. Soc., Faraday Trans.* 89 (1993) 3541.
- [3] H.-D. Beckhaus, C. Ruchardt, M. Smisek, *Thermochim. Acta* 79 (1984) 149.
- [4] P. Knauth, R. Sabbah, *J. Chem. Thermodyn.* 21 (1989) 203.
- [5] T. Kiyobayashi, M. Sakiyama, *Fullerene Sci. Technol.* 1 (1993) 269.
- [6] A. Xu-wu, H. Jun, B. Zheng, *J. Chem. Thermodyn.* 28 (1996) 1115.