

Simultaneous measurement of heat capacity and thermal diffusivity in solid–solid and solid–liquid phase transitions of *n*-alkane

Junko Morikawa, Toshimasa Hashimoto*

Department of Organic and Polymeric Materials, Tokyo Institute of Technology, Tokyo 152-8552, Japan

Received 2 June 1999; received in revised form 2 August 1999; accepted 23 August 1999

Abstract

A new technique analyzing Fourier spectrum of higher harmonics of temperature wave is proposed, which is called as Fourier Transform Temperature Wave Analysis (FT-TWA). It enables a simultaneous measurement of thermal diffusivity, heat capacity per unit volume, and thermal conductivity at a time by temperature scanning under multiple frequencies. This method was applied to solid–solid and solid–liquid phase transitions of *n*-alkane, which is usually used as a model of molecular crystal. The frequency dependence of heat capacity and thermal diffusivity in the phase transitions was observed. © 2000 Elsevier Science B.V. All rights reserved.

Keywords: Temperature wave; Harmonics; Thermal diffusivity; Heat capacity per unit volume; *n*-Pentacosane

1. Introduction

Thermal analysis that determines heat capacity is a basic method to study phase transition of substance as well as the diffraction method for structure determination. The phase transition of organic molecular crystal is a dynamic and non-equilibrium process, which is observed as a function of time experimentally. To understand the nature of these phase transition phenomena we should know all of the three thermal properties, not only static heat capacity but also thermal diffusivity and thermal conductivity that indicate the energy transfer rate. However, the measurement of heat transfer has some difficulty in the situation such as generating a latent heat or mode change of thermal transfer, which necessarily results

from a phase transition, so there are few examples for the simultaneous measurement of these three properties in the temperature range including a phase transition.

Authors proposed a method of determining thermal diffusivity and heat capacity [1–6] as a function of temperature, by the precise measurement of amplitude decay and phase delay of temperature wave propagating in the thin film specimen. In this study, we propose a new technique analyzing Fourier spectrum of higher harmonics of propagating temperature wave as an output signal by inputting a square wave. (In what follows it is called as Fourier Transform Temperature Wave Analysis (FT-TWA) [7].) It enables a simultaneous measurement of thermal diffusivity and heat capacity per unit volume by temperature scanning under multiple frequencies. This method was applied to solid–solid and solid–liquid phase transitions of *n*-alkane, which is usually used as a model of

* Corresponding author.

molecular crystal [8–16]. The heat capacity, thermal diffusivity, and thermal conductivity in the phase transitions were simultaneously observed and the frequency dependence of heat capacity and thermal diffusivity was analyzed.

2. Experimental

A specimen for the measurement was commercial normal pentacosane ($n\text{-C}_{25}\text{H}_{52}$) purified by recrystallization from acetone and/or ethanol hot solution. Its purity determined by gas chromatography (GC) was 99.0%.

By capillary action a liquid sample at 60°C was poured into a measurement cell (Fig. 1) made by two flat Pyrex 7740 plates, on which Au was sputtered as a resistor for heating and a resistive thermometer ($\sim 50\ \Omega$) with an area $1\ \text{mm} \times 4\ \text{mm}$, and a spacer was inserted to maintain a constant thickness ($30\ \mu\text{m}$).

Square pulse train with duty factor $a=0.2$ and frequency $f=15\ \text{Hz}$ generated by function synthesizer

(NF1942) was inputted on one Au resistor to generate a temperature wave by a.c. Joule heating. Another resistor was used as a temperature sensor to detect a temperature wave propagated in the thickness direction. The signal on the sensor was amplified by a two-phase lock-in amplifier (Stanford Research SR830). A schematic diagram of measurement system is shown in Fig. 2. The amplitude decay and the phase difference between the input and the output signals were obtained. The wave-form and the Fourier transform spectrum of the temperature wave was also observed by using an FFT analyzer (Ono Sokki CF360).

Specimen was heated at a constant heating rate of $0.2\ \text{K min}^{-1}$ and the signal of each harmonic (fundamental frequency, second, third and fourth harmonics) was detected in every 15 s, or for each 0.05 K. Fig. 3 shows a wave-form of the temperature variation on the sensor (T_s) detected as an electric voltage. The triangular wave-form in Fig. 3 was Fourier transformed as shown in Fig. 4. The higher harmonics were clearly observed up to the 13th-order in the mathematical rule [7] described below.

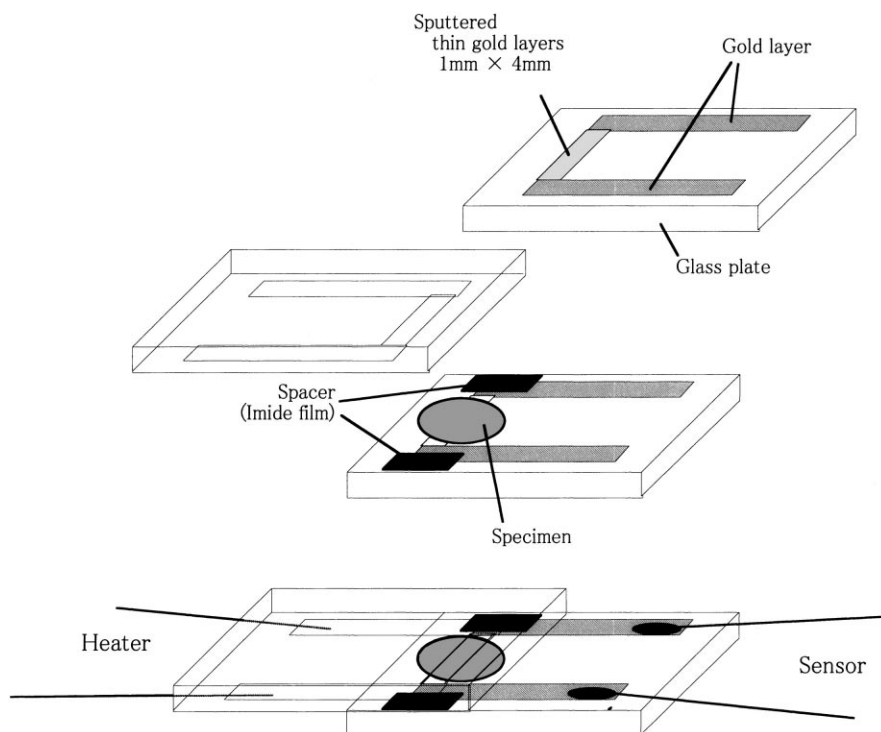

Fig. 1. Schematic diagram of the measurement cell.

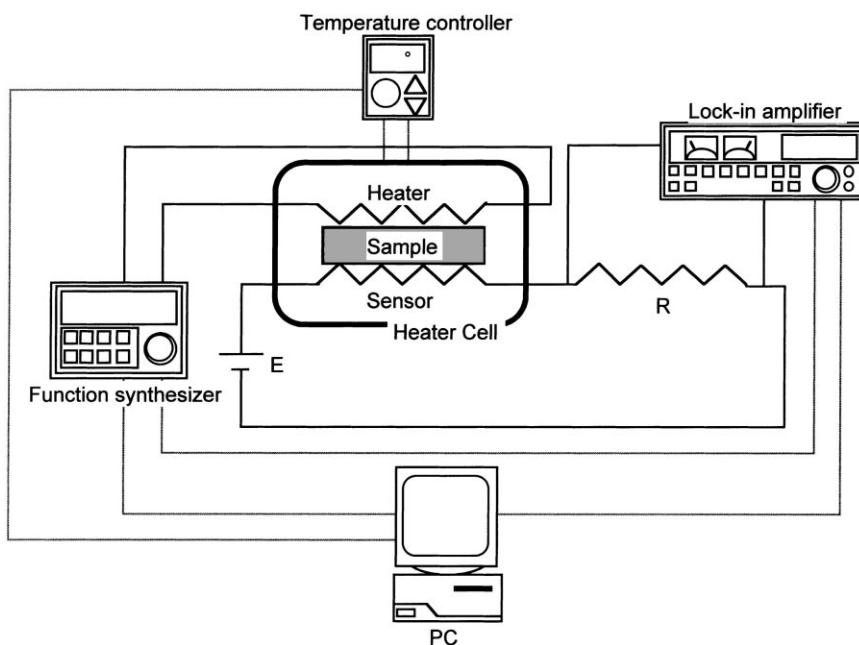

Fig. 2. Schematic diagram of the measurement system of FT-TWA.

In principle the signal at the frequency identical with the inputted stimulation (including harmonics) are phase locked-in as a maximum phase component. Noise signals at frequencies other than the reference frequency are rejected and do not affect the measurement. Therefore, d.c. heat flow, such as latent heat on the transition or the heat flow from the external heater

does not affect on the detection of thermal property. In addition, the one-dimensional propagation of the temperature wave in the thickness direction was detected, so the thermal property depends on the anisotropy of cohesive state of the specimen.

By solving one-dimensional diffusion equation only for the a.c. temperature component, temperature

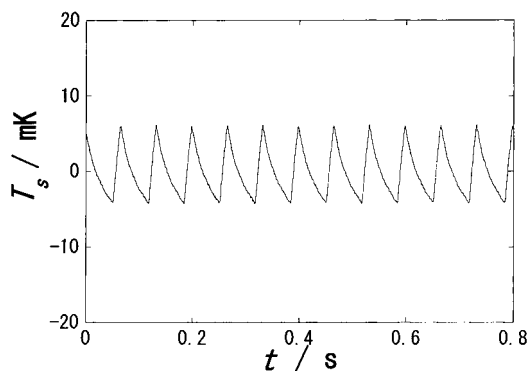

Fig. 3. Wave-form of temperature modulation detected on sensor observed by FFT analyzer in time domain. The frequency f and the duty factor a of input square pulse train are $f=15$ Hz, $a=0.2$. The specimen is $C_{25}H_{52}$ ($d=30$ μ m) and the substrate is Pyrex 7740 plate, at 27° C.

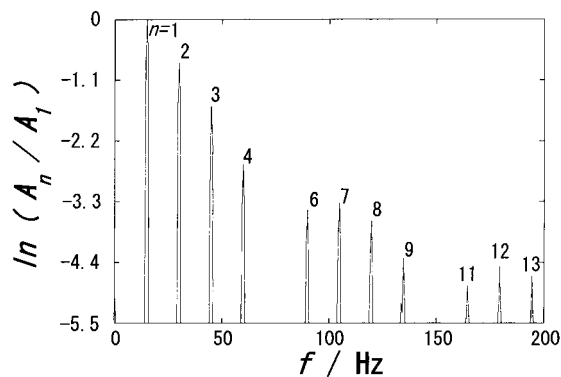

Fig. 4. Fourier transform spectrum of wave-form in Fig. 3 by FFT analyzer. The frequency f and the duty factor a of input square pulse train are $f=15$ Hz, $a=0.2$. The harmonics up to the 13th-order ($n=13$) are shown.

variation $T(x, t)$ on the rear surface ($x=d$) is followed as

$$T(d, t) = \frac{2c\sqrt{\alpha}}{(c\sqrt{\alpha} + c_s\sqrt{\alpha_s})^2} \frac{V_0^2}{SR_h} \times \sum_{n=-\infty}^{\infty} \left(\frac{\sin(an\pi)}{n\pi} \right) \left| \sqrt{\frac{1}{n\omega}} \right| \times \exp\left(-\sqrt{\frac{n\omega}{2\alpha}}d\right) \times \exp\left\{i\left(n\omega t - \sqrt{\frac{n\omega}{2\alpha}}d - \frac{\pi}{4} - an\pi\right)\right\} \quad (1)$$

where α is the thermal diffusivity, c the heat capacity per unit volume, subscript s refers to the substrate, ω , V_0 , a ($0 < a < 1$) are the angular frequency, the pulse height, and the duty factor of an inputted square pulse train, n the order of harmonic, d the thickness of the specimen, t the time, i is $(-1)^{1/2}$, S the area, R_h the resistance value of the heater, k is determined as $(\omega/2\alpha)^{1/2}$, and λ is the thermal conductivity. The phase delay ($\Delta\theta_n$) and the amplitude (A_n) of each harmonic are derived as

$$\Delta\theta_n = -\sqrt{\frac{n\omega}{2\alpha}}d - \frac{\pi}{4} - an\pi \quad \left(\text{if } kd \gg 1 \text{ or } k\lambda - k_s\lambda_s \cong 1, \right. \\ \left. \text{where } k = \sqrt{\frac{\omega}{2\alpha}} \right) \quad (2)$$

$$A_n = B \frac{2c\sqrt{\alpha}}{(c\sqrt{\alpha} + c_s\sqrt{\alpha_s})^2} \left| \frac{\sin(an\pi)}{n\pi} \right| \left| \sqrt{\frac{1}{n\omega}} \right| \times \exp\left(-\sqrt{\frac{n\omega}{2\alpha}}d\right) \quad (3)$$

The conditions for deriving Eq. (2) assumes that the temperature wave decays enough and/or the reflection of the temperature wave at the interface between the specimen and the substrate is negligible.

Heat capacity was determined experimentally considering the factor B as an instrumental constant determined by using a reference material Pyrex 7740 both for the substrate and the specimen, which has known thermal properties. B was obtained as a function of temperature and then c of $C_{25}H_{52}$ was

calculated with the amplitude of the detected signal. On the other hand, α can be directly obtained by phase delay without any reference material. Thermal conductivity λ was calculated by the relationship $\lambda = \alpha c$.

3. Results

This measurement technique is inputting thermal energy to substance and detecting the propagation of temperature wave as a change of intensive variable such as temperature. Therefore, directly obtained variables are thermal diffusivity and heat capacity per unit volume.

Figs. 5 and 6 show the experimentally obtained thermal diffusivity and heat capacity per unit volume as a function of temperature, respectively. Fig. 7 shows a product of α and c , which means thermal conductivity.

The transition temperatures of n - $C_{25}H_{52}$ observed by DSC and optical microscope were 45 and 54°C, which corresponds to the transition of orthorhombic (or monoclinic) to hexagonal, and hexagonal to liquid phase, respectively. Any peculiar change originated from the latent heat of phase transitions was not observed.

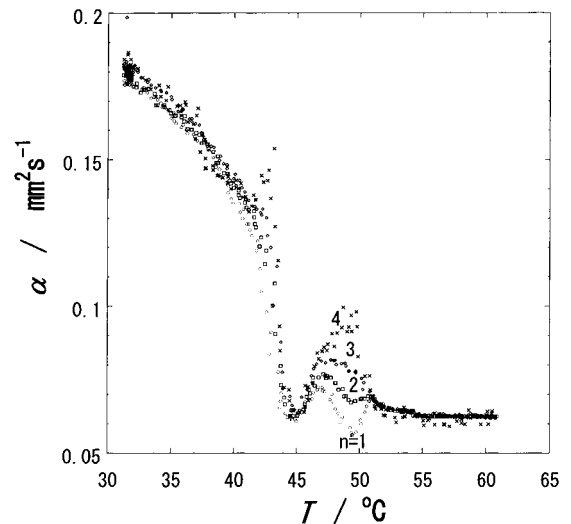

Fig. 5. Thermal diffusivity of n -pentacosane ($C_{25}H_{52}$) obtained from phase delay $\Delta\theta_n$ of the first to the fourth harmonics under heating condition. The heating rate is 0.2 K min^{-1} , the fundamental frequency is 15 Hz, and duty factor a is 0.2. (○) 15 Hz ($n=1$), (□) 30 Hz ($n=2$), (◇) 45 Hz ($n=3$), and (×) 60 Hz ($n=4$).

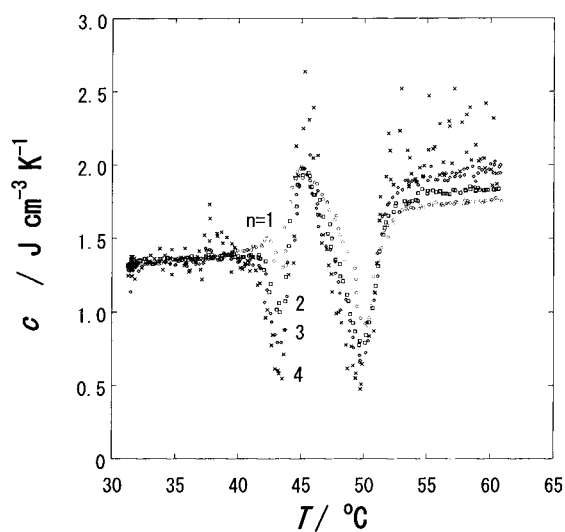

Fig. 6. Heat capacity per unit volume of *n*-pentacosane ($C_{25}H_{52}$) obtained from A_n of the first to the fourth harmonics under heating condition. The heating rate is 0.2 K min^{-1} , fundamental frequency is 15 Hz , and the duty factor a is 0.2 . (\circ) 15 Hz ($n=1$), (\square) 30 Hz ($n=2$), (\diamond) 45 Hz ($n=3$), and (\times) 60 Hz ($n=4$).

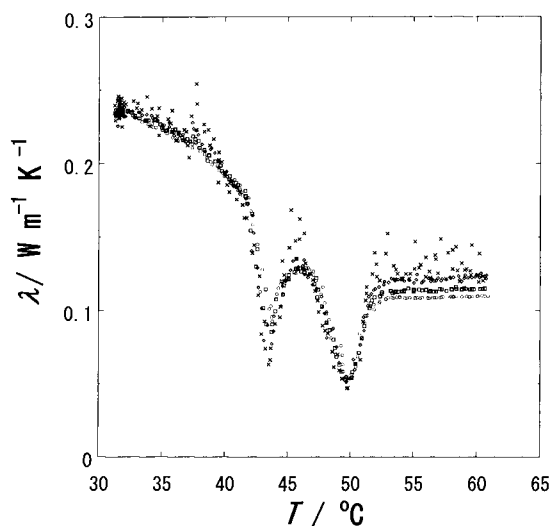

Fig. 7. Thermal conductivity of *n*-pentacosane ($C_{25}H_{52}$) obtained from $\lambda=zc$ of the first to the fourth harmonics under heating condition. The heating rate is 0.2 K min^{-1} , the fundamental frequency is 15 Hz , and the duty factor a is 0.2 . (\circ) 15 Hz ($n=1$), (\square) 30 Hz ($n=2$), (\diamond) 45 Hz ($n=3$), and (\times) 60 Hz ($n=4$).

Thermal diffusivity monotonically decreases with increasing temperature and shows a steep and complicated change on the phase transitions up to the completion of melting. Frequency dependence was clearly observed on the phase transitions, in contrast to no frequency dependence in the solid (in the lower temperature) and the liquid phases.

Heat capacity also shows a complicated change in the same temperature range and frequency dependence was observed as well. Of great interest was that the frequency dependence of α was in an inverse relationship with that observed for c . That is, c becomes a smaller but α shows a higher value in the higher frequency.

Thermal conductivity λ was determined by a product of c and α . In Fig. 7, λ shows a characteristic change in the phase transition region as observed in c and α , but it is noteworthy that the frequency dependence was not observed.

4. Discussion

Thermal properties α , c , and λ is sensitive to the molecular structure and shows a complicated change in the phase transition, in which an inter-molecular rearrangement occurred. On the other hand, the thermal properties in the solid phase at lower temperatures and in the liquid phase at higher temperature show monotonous temperature dependence and have no frequency dependence.

When external thermal energy is inputted to a substance, it is received as an atomic vibration (a term of heat capacity) which characterizes the substance and as a diffusion to the adjacent atoms (a term of thermal diffusion) in order to go to the equilibrium state. The occurrence of frequency dependence of a thermal property is caused by an existence of relaxation time in energy transfer corresponding to the time scale of experimental observation. In the phase transition region thermal energy needs to be converted, received and transported as a larger scale cooperative motion of molecules. It is presumed that relaxation time in this conversion process causes a frequency dependence of thermal property.

In this simultaneous measurement heat capacity and thermal diffusivity are closely related with each other on its temperature and frequency dependence.

Thermal conductivity, obtained by a product of thermal diffusivity and heat capacity, shows an energy transfer. It is suggested that thermal conductivity has no frequency dependence.

In addition, thermal conductivity (or thermal diffusivity) was sensitive to the cohesive state especially in the heat flow direction, so the structure change in the experimental conditions of this study was observed as a temperature-dependent thermal property. One of the reasons for the steep change of absolute values in the phase transition region is the arrangement of molecules. Anisotropy originates from the situation that the molecular motions in the phase transitions were permitted only in the x - y plane, while one-dimensional measurement was taken in the thickness direction. Therefore, n -alkane, which has a long molecular chain, was regulated in the orientation direction and causes a characteristic change in thermal properties.

Thermal properties are fundamental and can be observed for every substance. Simultaneous measurement of thermal properties at multiple frequencies by temperature scanning makes it possible to observe the precise molecular motion. A new concept for the dynamic thermal property will overcome the conventional theory in thermophysics.

References

- [1] T. Hashimoto, Y. Matsui, A. Hagiwara, A. Miyamoto, *Thermochim. Acta* 163 (1990) 317.
- [2] T. Tsuji, T. Hashimoto, *J. Thermal Anal.* 40 (1993) 721.
- [3] J. Morikawa, J. Tan, T. Hashimoto, *Polymer* 36 (1995) 4439.
- [4] T. Kurihara, J. Morikawa, T. Hashimoto, *Int. J. Thermophys.* 8 (1997) 505.
- [5] T. Hashimoto, J. Morikawa, T. Kurihara, T. Tsuji, *Thermochim. Acta* 304/305 (1997) 151.
- [6] J. Morikawa, T. Hashimoto, G. Sherbelis, *Thermochim. Acta* 299 (1997) 95.
- [7] J. Morikawa, T. Hashimoto, *Jpn. J. Appl. Phys.* 37 (1998) L1484.
- [8] M.G. Broadhurst, *J. Res. Natl. Bur. Stand. Sect. A* 66 (1962) 241.
- [9] K. Takamizawa, Y. Nagao, D. Irii, Y. Urabe, *Thermochim. Acta* 88 (1985) 205.
- [10] K. Takamizawa, Y. Nagao, Y. Urabe, *Polym. J.* 19 (1987) 981.
- [11] J. Doucet, I. Denicolo, A. Craievich, *J. Chem. Phys.* 75 (1981) 1523.
- [12] J. Doucet, I. Denicolo, A. Craievich, A. Collet, *J. Chem. Phys.* 75 (1981) 5125.
- [13] I.D.J. Doucet, A. Craievich, *J. Chem. Phys.* 78 (1981) 1465.
- [14] G. Unger, *J. Phys. Chem.* 87 (1983) 689.
- [15] G. Unger, N. Masic, *J. Phys. Chem.* 89 (1985) 1036.
- [16] T. Tsuji, T. Hashimoto, *Netsu Sokutei* 19 (1992) 156.