



Thermal desorption spectroscopy as a quantitative tool to determine the hydrogen content in solids

F. von Zeppelin, M. Haluška, M. Hirscher*

Max-Planck-Institut für Metallforschung, Heisenbergstr. 3, 70569 Stuttgart, Germany

Received 22 January 2003; received in revised form 15 March 2003; accepted 17 March 2003

Abstract

Thermal desorption spectroscopy (TDS) utilising a quadrupolar mass spectrometer is a highly sensitive and selective method to study the hydrogen desorption of hydrogen storage materials. For a quantitative analysis of the hydrogen storage capacity, the TDS apparatus can be consistently calibrated by using hydrogenated PdGd alloys or TiH₂ as standards. Owing to its hygroscopic nature, the use of CaH₂ as calibration standard leads to erroneous results. The chemical reactions during the thermal desorption of CaH₂ are analysed in detail.

© 2003 Elsevier Science B.V. All rights reserved.

Keywords: Titanium hydride; Calcium hydride; Thermal desorption spectroscopy

1. Introduction

Hydrogen storage is the major problem for commercialising fuel cell driven zero emission vehicles. The discovery of novel nanostructures has initiated a tremendous research activity in this field. Typically, the hydrogen storage capacity is determined either by the volumetric method (Sieverts type apparatus) or gravimetric measurements. For reliable volumetric measurements, at least 500 mg of a sample are required which are often not available for nanostructured materials. Furthermore, these novel nanostructured materials possess high specific surface areas and easily absorb different gasses which make gravimetric measurements extremely difficult and often erroneous. Thermal desorption spectroscopy (TDS) is highly selective and has an extremely high sensitivity even for sample masses as low as 1 mg. However, for a quanti-

tative measurement, the apparatus has to be calibrated with a well known calibration standard. Wang and McEnaney [1] calibrated a TDS apparatus for CO and CO₂ using calcium carbonate and calcium oxalate. For quantitative hydrogen measurements, typically, metals containing hydrogen may be applied to calibrate the output of the quadrupolar mass spectrometer [2,3]. Recently, Fernandez et al. [3] showed that titanium hydride is well suited as calibration standard. Nevertheless, owing to the arising controversy on hydrogen storage in carbon nanotubes [4,5], we evaluate different standards used in literature [6,7] concerning their suitability.

2. Experimental details

The hydrogen and water desorption kinetics were measured using a TDS apparatus which is shown schematically in Fig. 1. In the high-vacuum system, the sample can be heated up from room temperature

* Corresponding author.

E-mail address: hirscher@mf.mpg.de (M. Hirscher).

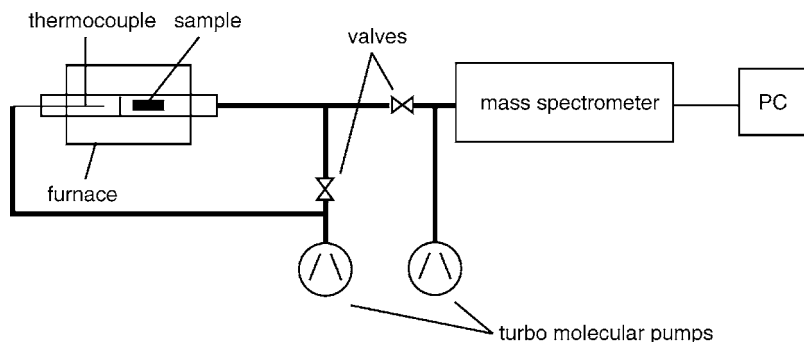

Fig. 1. Thermal desorption spectroscopy apparatus.

to 1120 K with a variable heating rate using a radiation furnace. The thermocouple is placed outside the analysing chamber to avoid any influence, however, under high vacuum to achieve conditions as close as possible to the sample. The partial pressures of the examined mass numbers were detected by a quadrupole mass spectrometer. During the measurement, the pressure inside the vacuum system was in the range of 10^{-8} to 10^{-2} Pa.

In order to determine the absolute value of the number of desorbed hydrogen atoms, three different kinds of calibration samples were used: commercial TiH_2 pieces and CaH_2 powder, as well as bulk samples of a $\text{Pd}_{95}\text{Gd}_5\text{H}_x$ alloy, which has been prepared in the institute [8].

The hydrogen content of the TiH_2 pieces was confirmed by chemical analysis to be of the nominal value. So, the amount of hydrogen within a sample could be determined by just weighing the sample. Since TiH_2 has a relatively high hydrogen content of 4.0 wt.% [9], only small sample masses of about 10 mg can be used without giving rise to a too high pressure increase within the TDS device at the heating rates used (up to 9.6 K/min).

Prior to hydrogenation, the $\text{Pd}_{95}\text{Gd}_5$ samples were heated in a high vacuum at 1273 K for 12 h. This was done in order to completely desorb any hydrogen that might have been stored within the sample. Afterwards, the samples were cleaned in nitrohydrochloric acid and acetone to remove oxide layers on the surface. Then the samples were hydrogenated at 350 K in a hydrogen atmosphere of 0.004 MPa for about 20 h and finally cooled down to room temperature. At this hydrogen pressure, no hydride phase

is formed, but the Gd atoms act as trapping centres for the hydrogen atoms [8], leading to hydrogen concentrations up to 5 at.%. Owing to this trapping, the activation enthalpy of long-range diffusion is slightly higher than in pure Pd and allows to handle the samples for several minutes at room temperature. Therefore, the hydrogen content of the $\text{Pd}_{95}\text{Gd}_5\text{H}_x$ samples can be determined by weighing the samples before and after the TDS measurements, denoting the mass difference to the desorbed amount of H_2 .

3. Evaluation of thermal desorption spectra

Typical TDS spectra for hydrogen can be seen in Fig. 2 for a constant heating rate. On one hand, such a TDS spectrum delivers a quick overview at which temperature the desorption takes place and, furthermore, may allow to determine the kinetics of the process by applying different heating rates [10]. On the other hand, the total number of desorbed hydrogen atoms can be derived from a TDS spectrum if the spectrometer had been previously calibrated by a known standard.

Assuming ideal gas behaviour, the hydrogen partial pressure p is given by

$$p(t) \cdot Q = n(t) \cdot RT, \quad (1)$$

where Q is the pumping speed of the system, n the molar gas flux at the mass spectrometer with temperature T at time t , and R is the gas constant.

Since we are using a turbo molecular pump, Q can be considered constant over the whole pressure range.

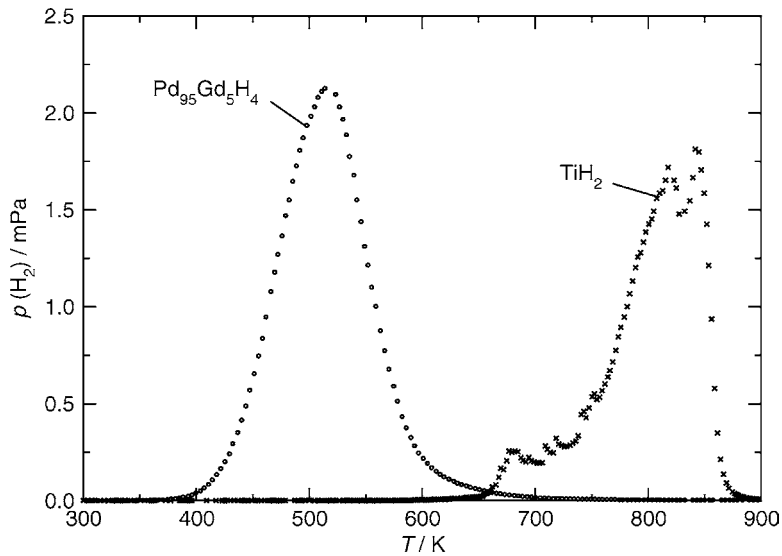

Fig. 2. Thermal desorption spectra of Pd₉₅Gd₅H₄ and TiH₂ (heating rate: 5 K/min).

Thus, integration of Eq. (1) delivers

$$Q \cdot \int_{t_0}^{t_1} p(t) dt = RT \cdot \int_{t_0}^{t_1} n(t) dt, \quad (2)$$

where t_0 and t_1 are starting and ending times, respectively, of the measurement.

The left-hand integral of Eq. (2) is the area A under the desorption curve, while the right-hand integral gives the total number N of the atoms which were desorbed during the measurement. Eq. (2) can be written as

$$N = \frac{Q}{RT} \cdot A. \quad (3)$$

Therefore, a TDS device can be calibrated by measuring the desorption spectrum of a sample which releases a known amount of hydrogen atoms during the measurement. Using such a standard, it is possible to determine the so-called *calibration constant*, i.e. the proportionality constant between N and A . Of course, one has to assure that the amount of the released hydrogen gives rise to a pressure increase that lies within the linear range of operation of the mass spectrometer. Ideal materials for calibration are metal hydrides, since they contain an amount of hydrogen which can be easily determined with a microbalance and is released while heating. For an easy handling, the hydride

should be stable at room temperature and non-reactive under atmospheric conditions.

4. Experimental results

Fig. 2 shows the characteristic hydrogen desorption spectra of Pd₉₅Gd₅H₄ and TiH₂ for a heating rate of 5 K/min. During the measurements, the signal of mass number 18, H₂O, was always monitored, however, showed no signal above the background level. The maximum desorption of Pd₉₅Gd₅H₄ occurs at about 500 K whereas the decomposition of TiH₂ starts above 650 K with a maximum rate between 800 and 850 K. The area under the desorption curve is proportional to the total number of H atoms desorbed (see Section 3). The mass of the Pd₉₅Gd₅H₄ sample was about 1 g corresponding to about 340 μg of hydrogen and in the case of TiH₂ about 6.5 mg corresponding to about 260 μg hydrogen.

Furthermore, the linear response of the signal of the mass spectrometer was tested by introducing different amounts of TiH₂, i.e. hydrogen, into the system. Over a wide range from 40 to 260 μg of hydrogen the system shows a linear dependence, yielding the calibration constant (Fig. 3). Additionally, the calibration constant was determined over a range of the heating rates from

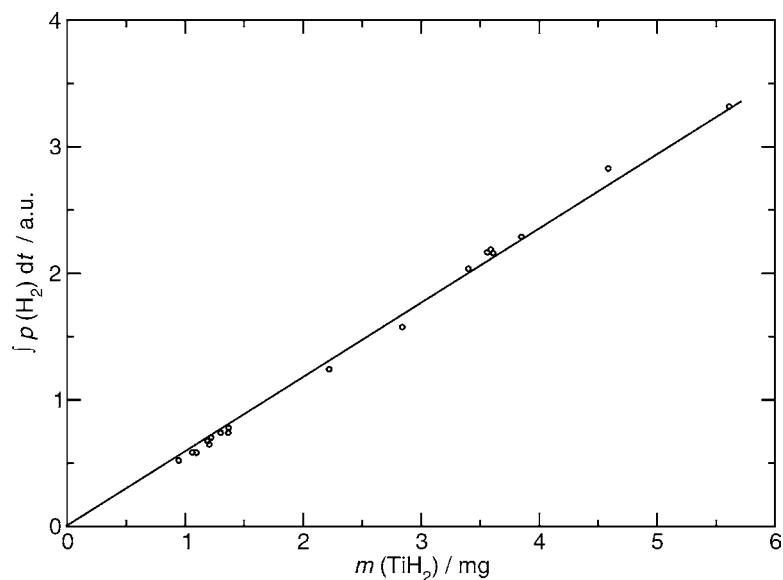

Fig. 3. Dependence of $\int p(\text{H}_2) dt$ on the TiH_2 mass.

1 to 10 K/min, showing no influence within the error limits (Fig. 4).

The third type of sample which was examined was CaH_2 powder. The hydrogen and water desorption spectra of CaH_2 with a heating rate of 5 K/min is shown in Fig. 5. The sample was exposed to air prior

to the TDS measurement only in order to determine its mass with a microbalance. The spectrum shows two maxima of hydrogen desorption. The first one at 660 K is accompanied by a large maximum of water desorption at the same temperature. At 970 K, there is a second and very large maximum of hydrogen desorption,

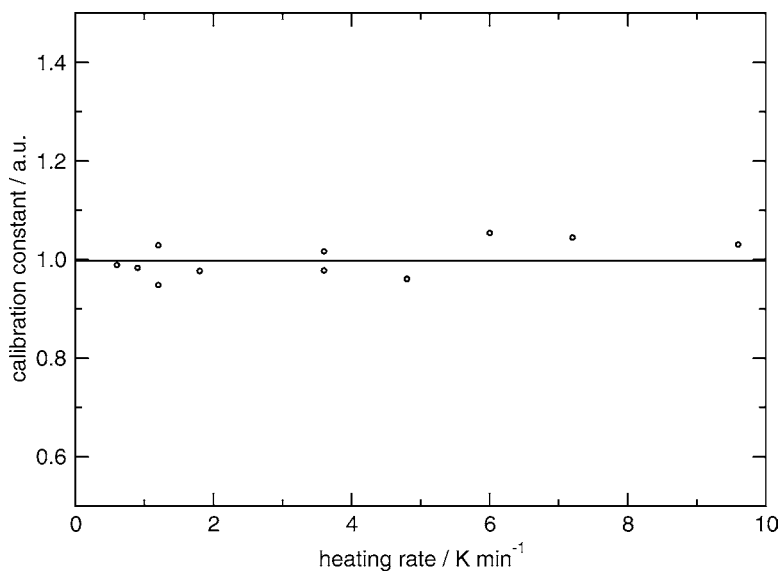

Fig. 4. Dependence of the calibration constant on the heating rate.

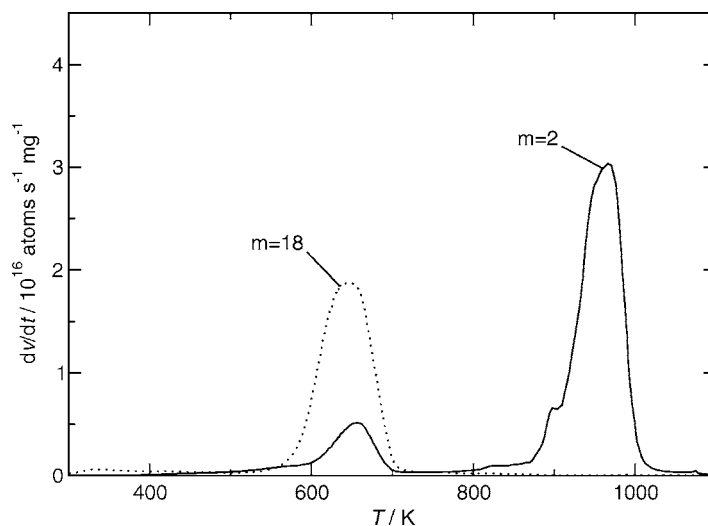

Fig. 5. Thermal desorption spectrum of CaH_2 with respect to hydrogen and water (heating rate: 5 K/min).

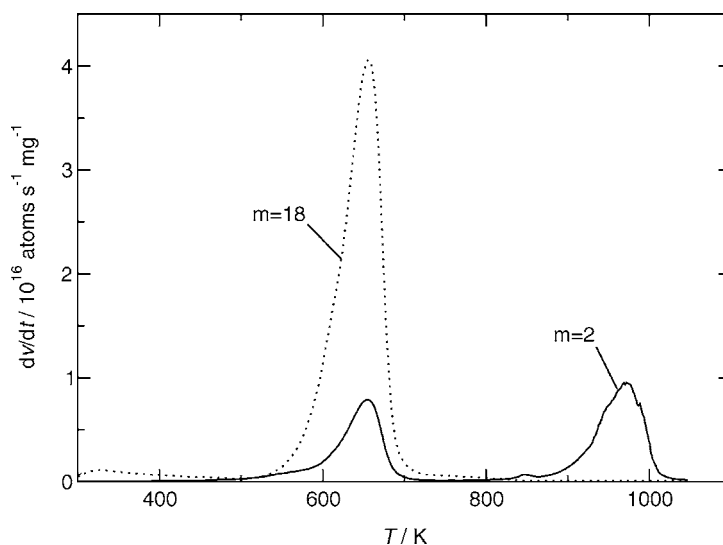

Fig. 6. Thermal desorption spectrum of CaH_2 with respect to hydrogen and water after exposure to air for 8 h (heating rate: 5 K/min).

but no water desorption can be observed at this temperature. From room temperature to 370 K, an additional small peak of water desorption can be seen.

After exposure of CaH_2 to air for several hours, the hydrogen and water desorption spectra change dramatically: while the hydrogen desorption maximum at 970 K decreases, the maximum at 660 K increases, accompanied by a huge increase of the water desorption (Fig. 6). Table 1 gives the number of desorbed hydro-

Table 1

Number of desorbed hydrogen atoms per mg sample mass after different times of deposition to air

	n_1 (660 K)	n_2 (970 K)
0 h	4.3×10^{18}	2.2×10^{19}
4 h	5.5×10^{18}	9.5×10^{18}
8 h	6.0×10^{18}	8.0×10^{18}
24 h	5.6×10^{18}	6.4×10^{18}

gen atoms per milligram of sample mass during the peaks at 660 and 970 K after different exposure times to air.

5. Discussion

For a reliable calibration of the TDS apparatus, a known amount of hydrogen has to be introduced into the high-vacuum system. This can be achieved by using a hydrogen-containing material which releases the hydrogen during heating. The evolution of the hydrogen should give rise to a pressure increase only within the range of linear operation of the mass spectrometer. Nevertheless, the signal should be well above the background level. By choosing the appropriate mass of the material, both, Pd₉₅Gd₅H_x and TiH₂ samples desorbing 100–400 μg of hydrogen, can be easily prepared. With these samples the TDS apparatus can be consistently calibrated for a quantitative analysis with an error of less than ±5%.

In the case of the Pd₉₅Gd₅H_x alloy, the hydrogen mass has to be determined by weighing the sample prior and after the TDS measurement. For TiH₂, the composition has to be determined by chemical analysis and the mass of the sample once, prior to the TDS measurement.

For Pd₉₅Gd₅H_x, a reproducible charging procedure is rather complicated containing several steps (see Section 2) and the charged samples have to be stored under liquid nitrogen. On the other hand, owing to its high desorption temperature, TiH₂ is stable at room temperature over years at laboratory conditions. Therefore, for routine calibration, the use of TiH₂ may be advantageous.

After a successful and consistent calibration using Pd₉₅Gd₅H_x and TiH₂, we examined the desorption behaviour of CaH₂. Fig. 5 shows the desorption spectrum of CaH₂ shortly exposed to air for weighing. In comparison to TiH₂, this spectrum consists of two maxima and during the first desorption maximum water is detected in addition to hydrogen. Exposed to air, CaH₂ absorbs moisture by [11]

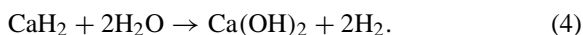

During the TDS heating run, the Ca(OH)₂ decomposes above 520 K:

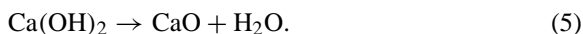

One part of the water may evaporate and the remaining part reacts with CaH₂ leading to the evolution of hydrogen:



The decomposition of the remaining CaH₂ into Ca and H causes the hydrogen desorption peak at 970 K:

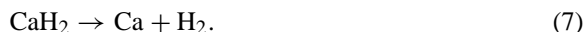

Owing to this hygroscopic behaviour of CaH₂, any exposure to air changes the composition depending on humidity and time.

Taking into account these reactions, it is possible to calculate a phase diagram of the hydrogen desorption in dependence of the composition of CaH₂ and Ca(OH)₂ (Fig. 7). The dashed line gives the hydrogen evolution due to the decomposition of Ca(OH)₂, according to Eq. (5) and the assumption that all H₂O reacts with CaH₂ according to Eq. (6). The dotted line is the hydrogen evolution due to decomposition of CaH₂ which remained after the first reaction. The sum of both reactions is given by the solid line. For the composition $x = 0.5$ and less CaH₂, all CaH₂ may react with water during the first step.

Furthermore, the initial composition of each sample can be determined by evaluating the number of desorbed hydrogen atoms for the two desorption maxima. Then the number of CaH₂ molecules, n_{hyd} , can be determined applying Eqs. (6) and (7) according to

$$n_{\text{hyd}} = \frac{1}{2}n_1 + n_2, \quad (8)$$

where n_1 and n_2 are the numbers of hydrogen molecules desorbed in the first and second maximum, respectively. Knowing n_{hyd} , the mass of CaH₂ is known and the difference to the total sample mass is denoted to Ca(OH)₂. The experimental values determined for the first (open circles) and second desorption maximum (closed circles) are included in the phase diagram (Fig. 7). Since not all H₂O of the decomposition of Ca(OH)₂ reacts with CaH₂, the experimental values for the H₂ evolution during the first maximum are below the dashed line. Consequently, more CaH₂ remains and decomposes during the second maximum and therefore, the measured values are above the dotted line. However, the total hydrogen desorption ('×' in Fig. 7), i.e. the sum of the first and the second maximum, is lower than the solid line.

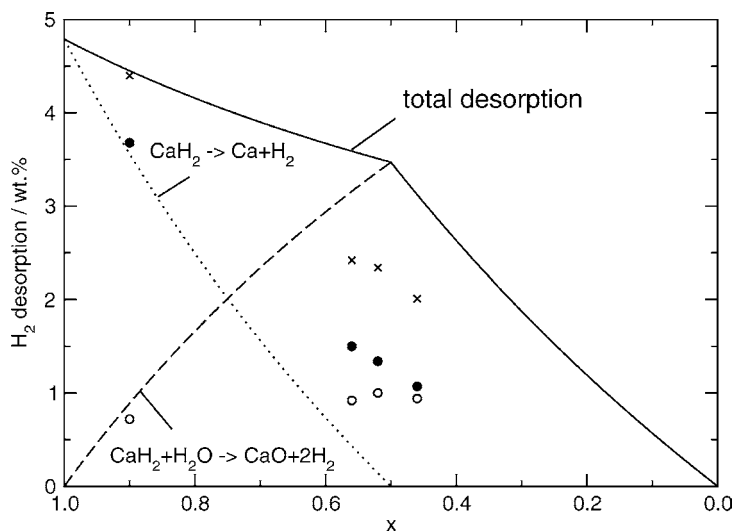

Fig. 7. Phase diagram of H₂ desorption and composition of $x\text{CaH}_2 + (1-x)\text{Ca(OH)}_2$.

If someone is not aware of the hygroscopic nature of CaH₂ and uses it as calibration standard, this person will account the sample mass as the mass of CaH₂ and denote the total amount of hydrogen desorbed to CaH₂. Under these circumstances, the calibration will be erroneous depending on the fraction of Ca(OH)₂ in the sample as shown in Fig. 8. For pure CaH₂ the calibration will be correct corresponding to a calibration factor of 1. However, with in-

creasing Ca(OH)₂ content, the factor increases. The line represents the total hydrogen desorption according to the solid line in Fig. 7. Practically, the deviation from the correct value is even worse, since the total desorption is actually smaller than the theoretical maximum value as shown by the crosses in Fig. 8. In the present case, already after 8 h exposure to air, the error in the calibration factor exceeds a factor of 2.

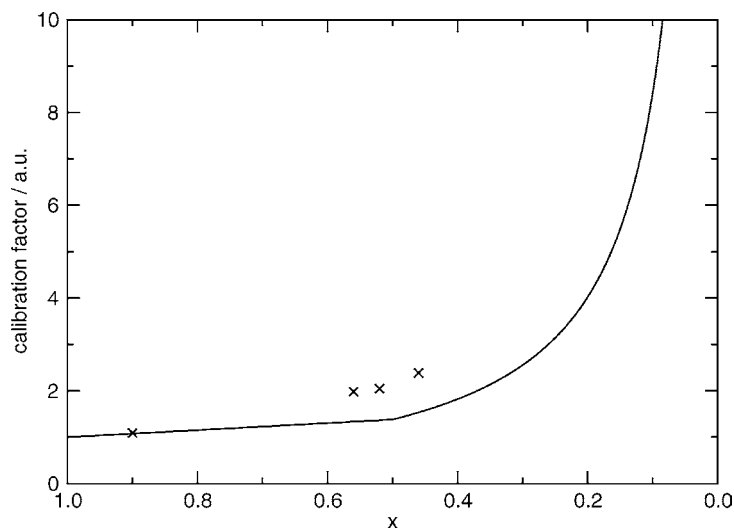

Fig. 8. Dependence of the calibration factor on the composition on $x\text{CaH}_2 + (1-x)\text{Ca(OH)}_2$.

6. Conclusions

For a quantitative analysis of the hydrogen storage capacity, the TDS apparatus can be calibrated by introducing a well-known amount of hydrogen molecules into the high-vacuum system. By choosing the appropriate mass of the hydrogen containing metal, the use of PdGdH_x or TiH₂ as calibration standard allows a quantitative analysis with an error of less than ±5%. In contrast, the use of hygroscopic hydrides, e.g. CaH₂, leads to an erroneous calibration due to the reaction with moisture during the sample handling.

Acknowledgements

We thank the Deutsche Forschungsgemeinschaft (DFG) for financial support (Grant no. HI465/8-1).

References

- [1] J. Wang, B. McEnaney, *Thermochim. Acta* 190 (1991) 143.
- [2] N. Mommer, M. Hirscher, F. Cuevas, H. Kronmüller, *J. Alloys Comp.* 266 (1998) 255.
- [3] J.F. Fernandez, F. Cuevas, C. Sanchez, *J. Alloys Comp.* 298 (2000) 244.
- [4] C. Zandonella, *Nature* 410 (2001) 734.
- [5] R. Dagani, *Chem. Eng. News* 80 (2) (2002) 25.
- [6] A.C. Dillon, T. Gennett, J.L. Alleman, K.M. Jones, P.A. Parilla, M.J. Heben, *Proceedings of the 2000 DOE/NREL Hydrogen Program Review*, NREL/CP-570-28890.
- [7] A.C. Dillon, K.E.H. Gilbert, J.L. Alleman, T. Gennett, K.M. Jones, P.A. Parilla, M.J. Heben, *Proceedings of the 2001 DOE/NREL Hydrogen Program Review*, NREL/CP-570-30535.
- [8] M. Ege, H. Kronmüller, *J. Alloys Comp.* 261 (1997) 231–241.
- [9] Hydride Properties Data Base, <http://hydpark.ca.sandia.gov/>.
- [10] A.M. de Jong, J.W. Niemantsverdriet, *Surf. Sci.* 233 (1990) 355–365.
- [11] Gmelin, *Handbuch der anorganischen Chemie*, Verlag Chemie, Bd. 28, Berlin, 1927, p. 275.