



Automatic proximate analyzer of coal based on isothermal thermogravimetric analysis (TGA) with twin-furnace

Youhui Xiong*, Taiyi Jiang, Xianhong Zou

National Laboratory of Coal Combustion, Huazhong University of Science and Technology, Wuhan, Hubei 430074, PR China

Received 9 December 2002; received in revised form 19 May 2003; accepted 29 May 2003

Abstract

A new type of rapid and automatic proximate analyzer for coal based on isothermal thermogravimetric analysis (TGA) with twin-furnace is introduced in this paper. This automatic proximate analyzer was developed by combination with some novel technologies, such as the automatic weighting method for multi-samples in a high temperature and dynamic gas flow circumstance, the self-protection system for the electric balance, and the optimal method and procedure for coal analysis process. Additionally, the comparison between standard values and the measurement values derived from the new instrument of standard coals was presented.

© 2003 Elsevier B.V. All rights reserved.

Keywords: Thermogravimetric analysis (TGA); Proximate analysis; Automatic measurement; Coal

1. Introduction

The evaluation of coal quality and the efficient utilization of coal resource are mainly based on the proximate analysis. In China the proximate analysis method is mostly referred to GB212-1991 [1]. This operation of a traditional proximate analyzer based on this method needs many manual procedures. The proximate analysis needs at least two-coal sample to be treated in different equipments, an oven is used for moisture measurement and a high temperature muffle furnace is used for ash and volatile matter analysis. At the same time, the weighting of the coal samples should be done manually. Thus, it is not only time consuming, but also toilsome at the high temperatures.

The automatic analyzer was developed for proximate analysis of coal in the 1980s. In the 1990s, the

automatic analyzer was introduced to China, such as TGA601 and MAC500 from LECO, USA. Compared with the method GB212-1991, it is automatic [2,3], but the instrument faces two challenges. Firstly, the instrument and the supply of accessories are expensive for Chinese customers. Secondly, the method of TGA601 or MAC500 is not consistent with GB212-1991, the result cannot be used as the law certificate for coal trade contract. Besides the earlier-mentioned shortcomings, the instrument is suitable for batch analysis and can get a rapid result. If there are only several samples, such as less than five, it is time consuming as well.

The programmed temperature thermogravimetric analyzer (TGA) is used for proximate analysis [4]. But the general TGA is only appropriate to the microanalysis of coal samples, the analytical speed and precision are relatively low. Mostly, it is applied for single sample. It is also too expensive for companies in China to purchase it. This makes the

* Corresponding author.

E-mail address: yhxiong@mail.hust.edu.cn (Y. Xiong).

application of TGA not popular for proximate analysis in China.

China is one of the largest producer and consumer of coal in the world. It is necessary to develop a new type of rapid automatic determinator for proximate analysis, which can be popularized in China.

2. Principle

Fig. 1 is the schematic diagram of the rapid determinator for proximate analysis. It consists of the base, outer shell (not shown in Fig. 1), ceramic fiber insulation heating furnace, furnace moving and position mechanism, multi-sample plate, electronic balance, gas flow meter, thermocouple, etc. Gas flow meter and electronic balance are assembled on the base. The furnace moving and position mechanism includes a horizontal moving motor and a vertical moving motor, each with a gear, which can be used to move the furnace. The position boards using two optical-electric sensors are mounted near the furnace body. Such arrangement ensure that the system can get position the furnace's movement automatically by a PC. Coal samples are placed on a multi-sample plate, which can take the sample down to the electronic balance to be weighted. The thermocouples are

installed in the furnaces to monitor and control the temperature of the two furnaces.

Fig. 2a is the schematic show of the twin-furnace system. It is a twin-furnaces placed horizontally and alongside, one is used as a high temperature furnace, another as a low temperature furnace. The twin-furnace can provide the proper temperature required by coal analysis. In the beginning of the development, a vertical twin-furnace structure shown in Fig. 2b was used, but during the period of experiment, this structure results in many problems, such as the temperature in the low temperature furnace is very difficult to keep lower than 105 °C because of the thermal radiation and conduction from the high temperature furnace on the top. At the same time, the distribution of temperature in low temperature furnace is not uniform, thus the measurement of moisture is unreliable. The twin-furnaces are ceramic fiber insulation tube heater with inner diameter 50 mm and length about 200 mm, the power is less than 1000 W. This new type of furnace has lower thermal capacity, the weight is about 1/5 of the traditional firebrick used widely in coal analysis laboratory in China. The heating speed is very fast, it only takes 5–8 min to reach an isothermal level of 800–900 °C. Two apertures are positioned on the furnace body, the top one is used to insert thermocouple to monitor the temperature,

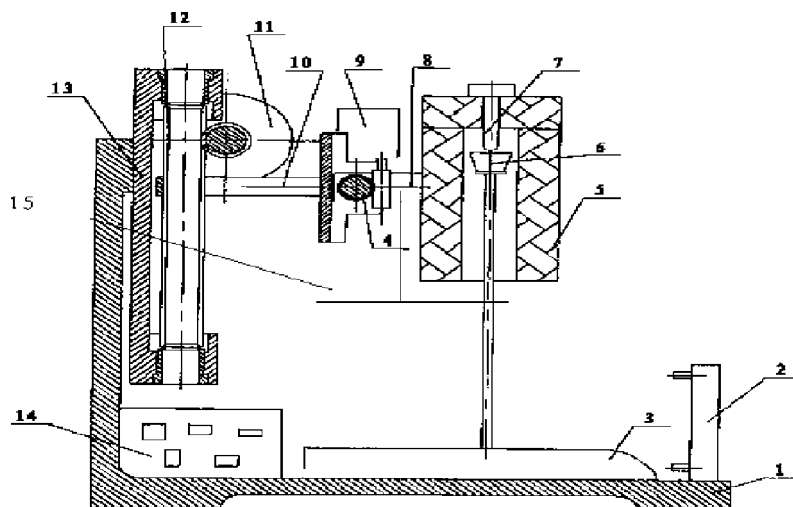

Fig. 1. Schematic diagram of the proximate analyzer based on twin-furnace: (1) base; (2) gas flow meter; electronic balance; (4 and 12) rack gearing; (5) furnace; (6) sample container; (7) thermal couple; (8) position board; (9 and 11) a motor; (10 and 13) sample supply board; (14) computer interface; (15) multi-sample plate.

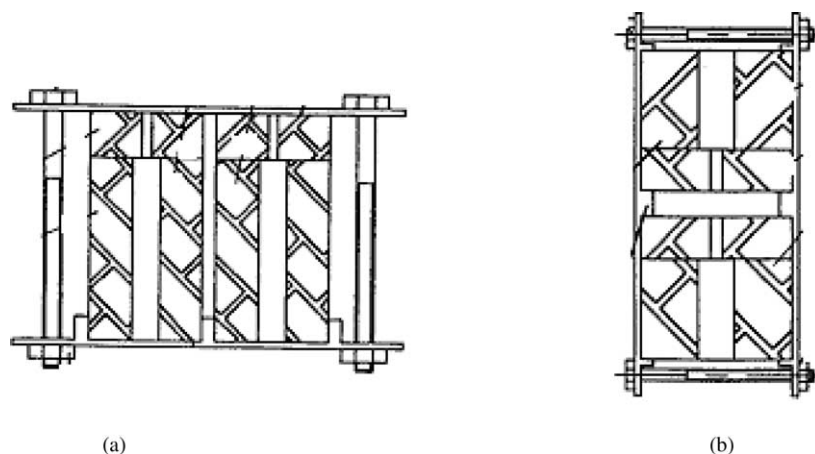

Fig. 2. Schematic diagram of the twin-furnace.

another is located aside on the bottom of the furnace, it is used to supply gases (N_2 or O_2) into the furnace.

The instrument controlling system is based on a PC with a PCM-711 general A/D and I/O card from EVOC for temperature controlling, horizontal and vertical movement, gases exchanging, on line weighting of the sample. The weight system is based on a Sartoris BS110S (110 g/0.1 mg) electric balance modified with a weighting pole, the weight can be transferred to PC by RS232.

After the program is powered on, the multi-sample plate and the twin-furnace will be positioned automatically with reference position by the positioning mechanisms. After that, the twin-furnace will be heated to 900 and 105 or 150 °C (according to the requirement of the measurement speed of moisture). The high temperature furnace is used to measure coal ash and volatile matter, the low temperature furnace is used for the measurement of coal moisture. After the furnace becomes isothermal, the computer will prompt to insert empty container and weight the dynamic and static weight of the container in the furnace with different temperature for the first time, the computer will record and save the data into computer for weight adjustment in high temperature and dynamic gas flow circumstance. During general analysis, the first step is to insert containers (at most 20) and then automatic weight them, at the same time the quantity and position of the samples will be determined automatically according to the measurement data. Then the computer will

prompt to put in the coal samples and repeat the procedures above to weight them. After that the apparatus will analyze the samples one by one. The low temperature furnace maintained at 105 or 150 °C and N_2 blowing is put in the vertical line of the sample to be analyzed, and then is lowered to a position when sample is in the center of the low temperature furnace, the weight data measured by electronic balance is transmitted to the computer. The measurement of moisture will not be completed until the weight difference is lower than the system setting, e.g. 1 mg in 30 s. Then the twin-furnace is lifted up and moved leftwards till the high temperature furnace operated at 900 °C and N_2 blowing is put in the vertical line of the sample, then lowered down to the sample. The weight of the sample will decrease rapidly. After 7 min, the weight data is obtained to complete the volatile matter measurement. After that, change the blowing gas from N_2 to O_2 , keep the furnace temperature at 815 °C (about 1 min to lower temperature from 900 °C), for fasting the analysis of ash content, temperature at 900 °C can also be used. The coal sample burns intensely in the furnace. When the weight-changing rate is lower than the setting, the ash measurement is completed. According to the weight losses of the sample in three different stages and the weight adjustment curve saved in PC, the moisture, volatile matter, ash and fixed carbon can be calculated automatically. At the same time, the heating value can be also derived by linear regression.

After the first sample is completed, the PC will give instructions for replacing O₂ with N₂, holding the temperature of 900 °C in high temperature furnace, lift up the furnace by computer and move it rightwards to the initial position before the moisture measurement (the low temperature furnaces is on the vertical line of the sample), the second sample will be on the same place as the first sample by turning the multi-sample plate. By repeating the procedures for the first sample described earlier, the apparatus will complete the automatic measurement of all samples with numbers recorded by container weighting.

As mentioned earlier, an electronic balance is used for the automatic weighting of the sample. The balance will be out of work when the sample's weight is over the measurement capacity. Sometimes, position deflection of the sample container are involved because of the inertia of the motor which moves the container, or the inefficiency of position sensors. In this case, the motor drives the container down to the balance, the container will press down the weighting pole. When the weight is over the measurement capacity of the balance, the balance will be out of work. To avoid such cases, a protection system is necessary to be designed.

As shown in Fig. 3, three protection triggers connected serially and a protection plate, which are connected to the control circuit, are mounted on the balance. The weighting pole is fixed in the center of the balance cover. The cover is round, under the cover there are three prominent points distributed, which can

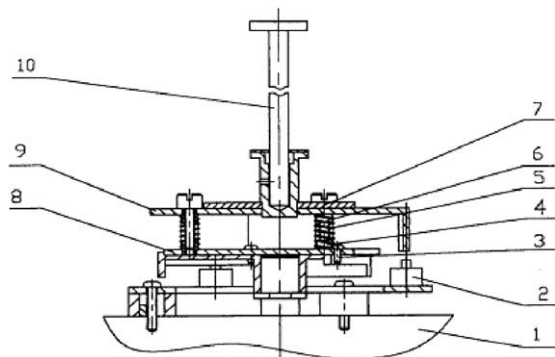

Fig. 3. Protection system of electric balance: (1) balance; (2) protection trigger; (3) screw; (4) bolt; (5) spring; (6) screw hole; (7) nut; (8) protection plate; (9) protection cover; (10) weighting pole.

be touched by the protection triggers. There is a 5 mm gap between the protection cover and the trigger points of the protection trigger. Each of the three bolts is encased in a spring; nut is screwed on the top of the bolt, so that the horizontal position of the protection cover can be adjusted. If the movement system is out of control, the prominent points on the cover turn the trigger on, so the PC gives instruction to the motor and turns furnace upwards, and alarm signal is introduced to the operator.

By using the novel technologies discussed earlier, automatic and rapid proximate analysis of coal samples can be derived.

3. Experiment and result

To decide the measurement precision of the apparatus designed, a series of experiments were made with GB (China National Standard) coal samples and three coal samples from the coal bank at National lab of coal Combustion.

The experiment conditions are as follows: temperature, moisture (150 °C), volatile matter (900 °C), ash (815 °C); Coal sample weight about 0.5 g. If the weight change of the sample is less than 1 mg in 30 s, the process will be ended for moisture and ash analysis; volatile matter is tested every 7 min according to the GB standard; Gas flow environment: N₂, 500 ml/min; O₂, 1000 ml/min. The comparison between experimental analysis and standard results is tabulated in Table 1. Because there are no data of moisture for GB coals and other three coals, the moisture results are analyzed by GB oven method.

The analysis results discussed earlier make clear that most experimental data meets the GB standards. For moisture measurement the sample is heated at 150 °C, the analysis time is minimized to 5–7 min, and the corresponding data are some lower than GB, but still within the error required for most coals. For volatile matter measurement, the measure results of the samples which volatile matter is <30% are precise. For those samples, which the volatile matter is up to 30% (GBW11109B), because of the method using sample container without lid, there are some errors in comparison with the GB results. For ash analysis, besides the sample GBW11109B with an error of about 0.7%, there are no obvious errors for other samples.

Table 1

Comparison between results by GB method and the instrument designed (air dried basis)

| Coal | Moisture (%) | | Volatile matter (%) | | Ash (%) | | Fixed carbon (%) | |
|-----------|--------------|----------|---------------------|----------|---------|----------|------------------|----------|
| | GB | Designed | GB | Designed | GB | Designed | GB | Designed |
| GBW11104B | 2.38 | 2.26 | 5.94 | 5.70 | 26.35 | 26.84 | 67.71 | 67.46 |
| GBW11107B | 1.69 | 1.60 | 28.89 | 27.97 | 8.43 | 8.43 | 62.66 | 63.60 |
| GBW11109B | 4.12 | 4.04 | 34.08 | 35.04 | 13.89 | 14.59 | 52.03 | 50.37 |
| GBW11111A | 1.10 | 1.20 | 25.22 | 25.65 | 9.99 | 10.23 | 64.79 | 64.12 |
| GBW11112A | 1.67 | 1.58 | 11.86 | 11.40 | 21.26 | 20.87 | 66.88 | 67.73 |
| Taixi | 1.02 | 1.04 | 11.91 | 12.25 | 6.26 | 6.38 | 81.83 | 81.83 |
| Yongcheng | 1.46 | 1.49 | 12.66 | 12.93 | 10.23 | 10.29 | 77.11 | 76.78 |
| Xishan | 1.83 | 1.78 | 12.33 | 12.05 | 16.78 | 16.58 | 70.90 | 71.37 |

Using the method and instrument described in the paper, the rapid proximate analyzer of a coal sample can get the total results of proximate analysis in 20–30 min. In comparison with the GB method used widely in China, which need at least 2–3 h, the analysis speed is increased greatly. Compared with TGA601 or MAC500 from LECO, the speed of the instrument designed is faster for one sample. However, it is difficult to analyze 19 samples once a time as the LECO instruments. If the samples are more than eight, the analysis speed of the instrument is slower than TGA601 or MAC500; but for samples less than eight, the analysis time is shorter, at the same time, it is more flexible for the method to analyze each sample one by one and need less power and less gas consuming. Another advantage is that the price, the price of the new instrument designed is lower than one-third of the TGA601 or MAC500.

By using computer control, the instrument can be used for quick measurement of sample for just moisture, or ash, or carbon in ash analysis. As mentioned earlier, the analysis time is between 20 and 30 min, the analysis time is an important index for coal combustion characteristics. Formerly, the coal combustion characteristics is derived from programmed temperature TGA [5], it is some different from the realistic combustion process and the sample weight is just 5–50 mg. Now the instrument can also be used to access the coal combustion characteristics in isothermal conditions. The temperature, gas flow rate and sample weight should be optimized for combustion characteristics testing. The study of the coal combustion characteristic on isothermal TGA on the instrument designed will be introduced in another paper.

4. Conclusions

1. By using the novel technologies, such as the automatic weighting of multi-samples at a high temperature and dynamic gas flow circumstance, the self-protection system for the electric balance, and the optimal methods and procedures for automatic analysis process, the rapid and automatic measurement of proximate analysis can be realized.
2. The instrument designed can get the proximate analysis results of moisture, volatile matter ash and fixed carbon within 20 or 30 min. It is not only rapid, but also meets the requests of GB standard value for most cases.
3. The instrument designed can meet the demand of rapid and automatic proximate analysis of coal in China, it is localized and the price is less than one-third of the TGA601 or MAC500.
4. By upgrading the computer program and optimizing the temperature, gas flow rate and sample weight parameters, the instrument designed can be applied in studying the coal combustion characteristic in the future.

References

- [1] China National Standard, GB212, 1991.
- [2] MAC-500 Proximate Analyzer Instruction Manual, LECO Corporation, 1989.
- [3] US Patent 4522787.
- [4] M.C. Mayora, M.T. Izquierdo, J.M. Andres, B. Rubio, *Thermochim. Acta* 370 (2001) 91–97.
- [5] X. Sun (Ed.), *Combustion Testing Technologies and Methods for Thermal Coals* (in Chinese), China Electric Power Publishing Company, Beijing, 2002.