

# On calorimetry by optical beam deflection method

Akil Salloum\*, Yomen Atassi

*Department of Applied Physics, Higher Institute for Applied Sciences and Technology, P.O. Box 31983, Damascus, Syria*

Received 17 March 2003; received in revised form 17 June 2003; accepted 17 June 2003

## Abstract

In this work, we analyze different factors that may affect heat measurements, in a device, based on the optical beam deflection method (OBD). We demonstrate that it is possible to improve the heat limit of detection (HLOD) of the device by increasing its sensitivity using a proper cell or a proper monitoring phase. On the other hand, we prove experimentally that the gradient of the refraction index is almost vertical, so it is possible to apply a theoretical model based on one-dimensional heat propagation to predict the temporal behavior and the magnitude of the deflection beam.

© 2003 Elsevier B.V. All rights reserved.

*Keywords:* Calorimeter; Optical beam deflection; Heat measurements; Heat transfer; Refraction index gradient; Temperature gradient

## 1. Introduction

The optical beam deflection method (OBD) is based on mirage effect which appears when an index gradient is created in a medium, so the light beam undergoes an angular deflection when passing through this medium. This gradient of index can be produced by inducing a temperature gradient, or a density gradient in the medium. Historically, the OBD technique has been used before in schlieren technique [1,2] three centuries before the invention of lasers. The first observation of the schlieren effect was reported by Hooke and Huygens in the 17th century. Schlieren measurements were used in the manufacture of optical instruments for astronomical studies. Its application to fluid and heat transfer investigations is due to Töepler (1864), who gave it the name schlieren, the German term for striations or inhomogeneities. August Töepler developed the first basic apparatus for flow visualizations by using a knife-edge filter to produce a black-and-white image in which the intensity of the light is related to the density/temperature gradients in the optical field.

The development of lasers allowed perfecting the OBD method. In fact, the laser beam has a very low divergence and therefore, it can probe a small portion of the sample.

On the other hand, it minimizes the dispersion effect since it is a monochromatic light.

Then, the OBD method was widely used in photo-thermal spectroscopy [3–5], where photo-induced changes in the optical and thermal characteristics of a sample are measured. The method was also applied to probe an induced concentration gradient near an electrode in a solution [6]. Other applications in optical measurements can also be found [7].

Using the OBD technique, Wu et al. [8] have demonstrated for the first time that laser probe beam deflection, induced by the enthalpy change of a chemical reaction in a liquid phase, can be used for quantitative analysis. The same technique was used later in monitoring and analyzing a chemical reaction process [9], and in monitoring gas diffusion from one liquid phase to another [10]. Baptista and coworkers [11] have used the same device to measure the enthalpy of some chemical reactions in water. Their measurements were with a heat limit of detection (HLOD) of 60 mJ and an uncertainty of 15% which are both too high compared with the ones obtained using available micro-calorimeters.

In this work, we have carried out some new experiments using a similar device as the one used by Wu. These experiments permit to analyze the sources of imperfection in heat measurements of this device. Taking into account the experimental results, we have used a theoretical model of heat transfer to find numerically the time-evolution of the output signal of the device. The temporal behavior of the numerically calculated signal was in a reasonable agreement with the experiment, but the maximum of the calculated signal

\* Corresponding author. Tel.: +963-11-513-5700; fax: +963-11-223-7710.

E-mail address: [akil.salloum@hiast.edu.sy](mailto:akil.salloum@hiast.edu.sy) (A. Salloum).

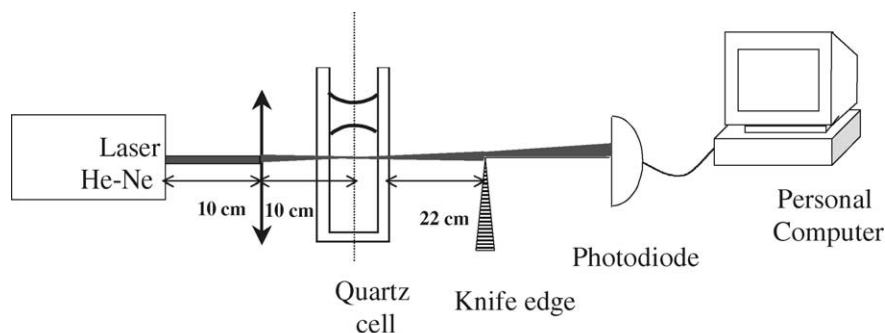

Fig. 1. Experimental set-up.

was higher than the experimental one. In order to investigate the reasons for this difference, we considered different causes of imperfection in the device that might be taken into account to improve its sensitivity.

## 2. Experimental device

Fig. 1 illustrates the experimental setup with some details of the instrumentation, it is similar to the ones used before [8,9,11].

A He–Ne laser (wavelength 632.8 nm, output power 1 mW) is focused by a lens of 10 cm focal distance to a quartz cell (1 cm × 1 cm × 4.5 cm). Two immiscible solvents are added to the cell, the upper one is the reaction phase where a quantity of heat is produced (by a chemical reaction in aqueous medium), or added (by adding hot water), and the lower solvent (CCl<sub>4</sub>) constitutes the monitoring phase where the heat is detected. (In other experiments, we used a high viscosity sucrose solution as a monitoring phase.) The heat produced in the upper phase propagates to the lower one creating an index gradient, the laser beam passes through the monitoring phase (several millimeters under the interface), and the index gradient induces the beam deflection. To measure this deflection, 50 ± 0.3% of the beam intensity is projected on a horizontal knife-edge block and another half of the beam is aimed at a photodiode (UDT-PIN 10DP 9341-1). The signal is digitized by a 12-bit A/D board (Vernier Software—Multipurpose Laboratory Interface) installed in a 486 PC. The sampling speed was 20 data/s. The recording time of each experiment is 350 s.

All chemicals used are of spectroscopic grade (Merck). Deionized water is used in the experiments.

## 3. Results and discussion

To study and analyze the device, we used the simplest way to produce heat in the reaction phase by adding a precise quantity of hot water with a known temperature to the upper phase, composed initially of a quantity of pure water measured precisely. The delivery of hot water to the aqueous phase was done with a lot of precaution, in order to

determine precisely the actual water temperature being delivered to the aqueous phase.

- We immersed the pipette used for adding water, in a thermostat bath containing hot water and waited several minutes to arrive at the thermal equilibrium, to note down the temperature of the system (hot water, pipette).
- We repeated each experiment several times to make sure that it is reproducible.
- We traced, using hot water of varying temperatures, the calibration curve of this calorimeter: temperature as a function of the beam intensity. Then, we carried out some experiments where heat is liberated in the aqueous phase by an acid–base neutralization reaction. We verified using the calibration curve that the enthalpy of the reaction measured by this method was in good agreement with the enthalpy measured by other conventional calorimetric methods.

While adding hot water to the reaction phase, the photodiode delivers a signal that decreases in several seconds to reach a minimum, then it rises during a period of time of the order of 200 s (Figs. 2 and 3). We noticed a delay between the time of adding hot water and the time when the signal starts to decrease. This delay, increases as the distance between the entering point of the laser beam and the interface increases. We also noticed that the time required to reach a minimum becomes longer, and the signal deflection decreases (Fig. 3).

The photodiode permits to measure the intensity of the beam. In order to calculate the beam deflection from the signal registered by the photodiode, we verified experimentally that the beam intensity has a gaussian distribution obtained by displacing vertically the knife-edge using a micro-vice and measuring the variation of the intensity  $I$  with the displacement  $d$ , which is clearly explained in the upper scheme of Fig. 4. Then, we verified that the curve  $I = f(d)$  is well-fitted with a function of the form:

$$\begin{aligned}
 I(d) &= C \int_{-\infty}^{+\infty} \int_d^{+\infty} \exp\left(-\frac{u^2 + v^2}{a^2}\right) du dv \\
 &= I_0 \int_d^{\infty} \exp\left(-\frac{u^2}{a^2}\right) du.
 \end{aligned}$$

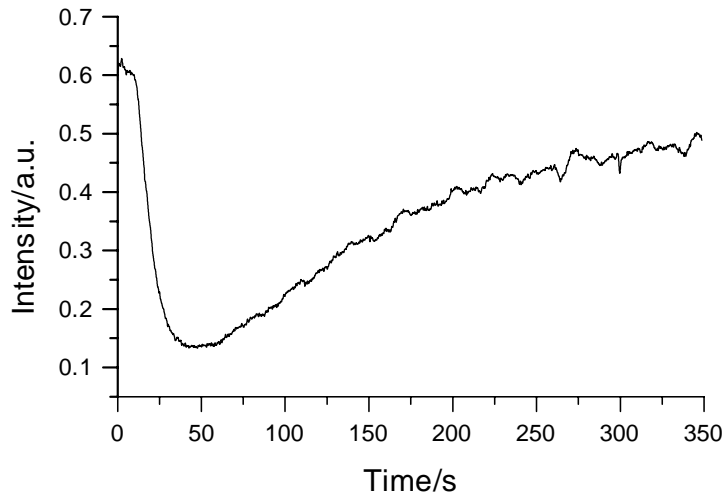

Fig. 2. Signal delivered by the photodiode after adding 0.2 ml of water at 53°C, the initial temperature is 26°C.

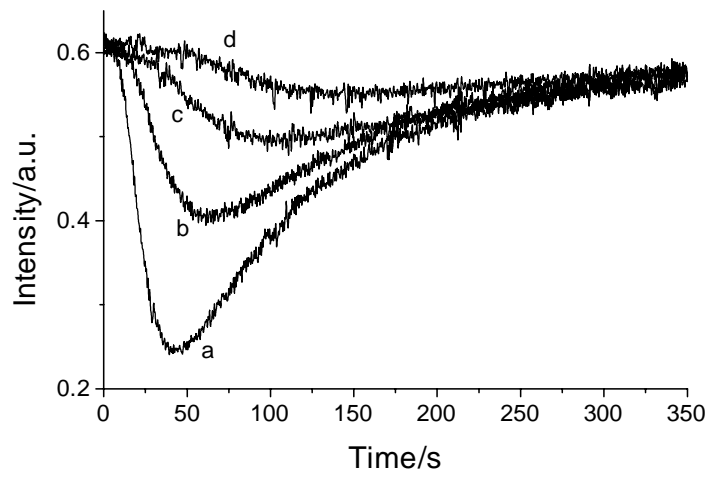

Fig. 3. Behavior of the signal when one changes the position of the entering point of the laser beam (distances from the interface: (a) 3.2 mm; (b) 5.4 mm; (c) 7.6 mm and (d) 9.8 mm).

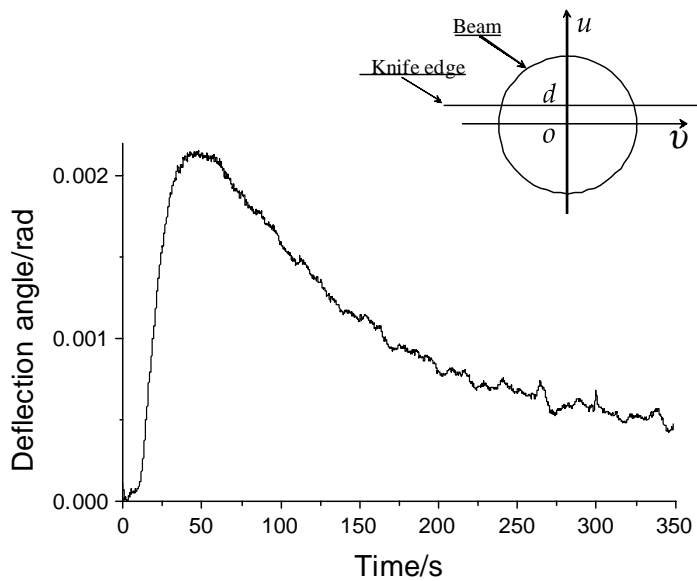

Fig. 4. Beam deflection of experimental data of Fig. 2 taking into account the gaussian distribution of laser beam intensity.

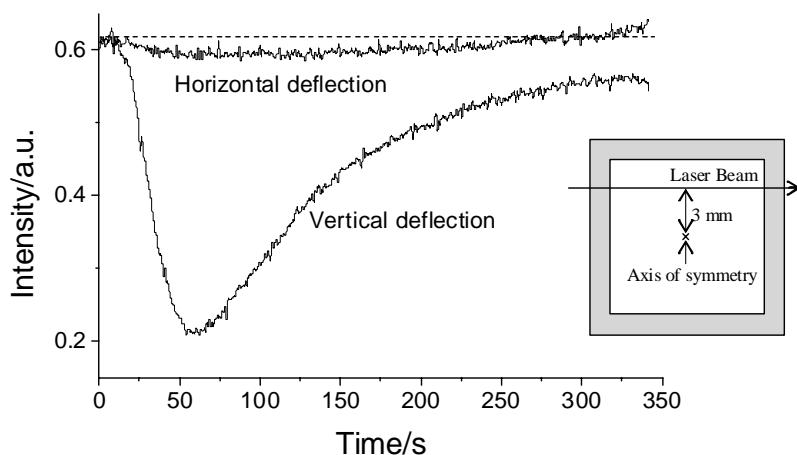

Fig. 5. Horizontal and vertical beam deflection signals. Laser beam passes into the cell 3 mm from the axis of symmetry.

We determined  $I_0$  and  $a$ , so that if we have a value of  $I$ , we can deduce the corresponding value of  $d$ .

In order to determine the angle of beam deflection, we used the relation:

$$\theta \approx \tan \theta \approx \frac{d}{D}$$

where  $\theta$  is the angle of beam deflection,  $d$  is the displacement of the laser beam at the knife-edge due to the deflection, and  $D$  is the distance between the knife-edge and the cell. So, the registered curve  $I = f(t)$  of Fig. 2, can be converted numerically into: deflection as a function of time, as in Fig. 4.

#### 4. Heat-flow study

In order to study the heat flow in the monitoring phase, we performed a new experiment in which the knife-edge is placed vertical in order to detect a possible horizontal deflection. As it is obvious that there is no horizontal deflection when the beam passes through the axis of symmetry of the cell, we let the laser beam pass at a distance of 3 mm from this axis. We noticed (Fig. 5) that horizontal beam deflection (vertical knife-edge) is small compared to the vertical deflection (horizontal knife-edge). On the other hand, we verified that the vertical deflection does not change significantly when we shift the entering point of the beam, horizontally. These results permit to conclude that the index gradient and the temperature gradient are almost vertical. This means that the heat flow is almost vertical. We conclude from this experiment that it is possible to apply the approximation of one-dimensional heat propagation.

#### 5. Modeling the temporal behavior of the signal

The solution of heat equation in the case of non stationary propagation is studied in [12]. The solution of heat equation in the case of one-dimensional heat propagation, if the

calorific capacity  $c$ , and the thermal conductivity  $\kappa$  of the medium are constants, is:

$$T(z, t) = T_0 + \frac{Q}{2\sqrt{\pi\kappa ct}} \exp\left(-\frac{cz^2}{4kt}\right) \quad (1)$$

where  $z$  is the position on the vertical axis oriented downwards,  $t$  is the time,  $T_0$  is the initial temperature of medium, and  $Q$  is the heat quantity injected in the medium at the position  $z = 0$  taken at the interface.

We can assume that the calorific capacity and the thermal conductivity of  $\text{CCl}_4$  are constant, in the temperature range maintained during the experiment [13].

On the other hand, the trajectory of a light ray is monitored by the differential equation:

$$\frac{d}{ds}(n\vec{u}) = \vec{\text{grad}}n$$

where  $s$  is the curvilinear abscissa,  $\vec{u}$  is the tangent unitary vector of the ray trajectory, and  $n$  is the refraction index. Using the fact that  $\vec{\text{grad}}n$  is vertical (parallel to  $Oz$ ), we find:

$$\frac{\partial^2 z}{\partial x^2} = \frac{1}{n} \frac{\partial n}{\partial T} \frac{\partial T}{\partial z} \quad (2)$$

where  $Ox$  is the horizontal axis oriented in the initial beam direction and has origin as the entering point of the beam to the monitoring phase.

Using Eq. (1) we can calculate  $\partial T/\partial z$ , and Eq. (2) becomes:

$$\frac{\partial^2 z}{\partial x^2} = -\frac{Q}{4n} \frac{\partial n}{\partial T} \sqrt{\frac{c}{\pi\kappa^3 t^3}} z \exp\left(-\frac{cz^2}{4kt}\right) \quad (3)$$

Then, we can calculate  $\partial n/\partial T$  using the Lorentz–Lorenz relation [5]:

$$\frac{n^2 - 1}{\rho(n^2 + 2)} = \frac{R}{M} \quad (4)$$

where  $M$  is the molar mass of  $\text{CCl}_4$ ,  $\rho$  is the density of  $\text{CCl}_4$  which depends on temperature, and  $R$  is the molar refractivity which does not change with temperature.

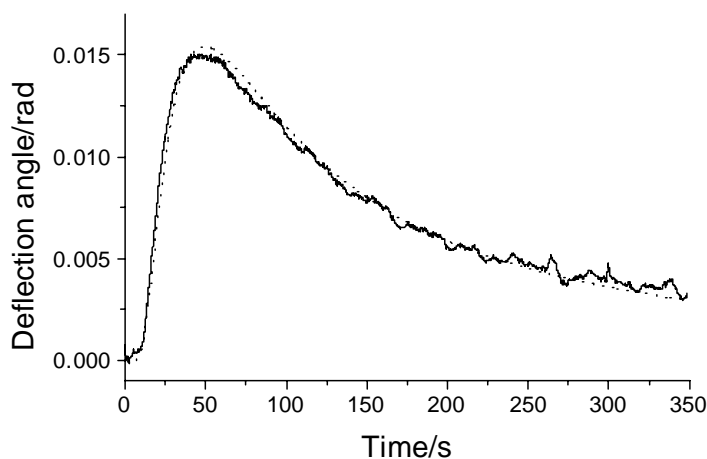

Fig. 6. Comparison between the calculated beam deflection using the proposed model (dashed curve) and the experimental curve of Fig. 4 after multiplying the later by a factor of 7.2.

The variation of density in the interval (290–320 K) is almost linear [13]. Using this fact and the data about density of  $\text{CCl}_4$  [7], we find:

$$\frac{\partial \rho}{\partial T} = -2 \text{ kg m}^{-3} \text{ K}^{-1} \quad (5)$$

The refraction index of  $\text{CCl}_4$  is 1.459 at  $T = 293 \text{ K}$  [14], we find using Eqs. (4) and (5):

$$\frac{\partial n}{\partial T} \approx -6.6 \times 10^{-4} \text{ K}^{-1}.$$

This value is slightly different from the one given by Dovichi [4]:

$$\frac{\partial n}{\partial T} = -6.12 \times 10^{-4} \text{ K}^{-1}.$$

The numerical solution of Eq. (3) using the software “Mathematica” allows drawing the graph  $(\partial z / \partial x)_{x=10 \text{ mm}}$  as a function of time ( $t$  has 7000 values, and varies in the interval  $0 < t \leq 350$ ), which represents the angle of beam deflection. In order to calculate the angle at the emergence of the cell we have to take into account the beam refraction when it passes to air.

But it is essential here to determine the value of  $Q$ ; the injected heat at position  $z = 0$  and time  $t = 0$ . If we take the value of  $Q$  as the heat released in the upper phase by unity of surface, we find a graph with the same temporal behavior as the one deduced from experimental data, but with a maximum of 7.2 times higher as it is shown in Fig. 6, where we superimposed the theoretical and the experimental curves after multiplying the later one by a factor of 7.2. So, it is necessary to investigate the origin of this difference.

## 6. Origin of the difference between experimental results and theoretical ones

One of the factors that might be the origin of this difference is the evaporation of water in the upper phase. We

carried out two identical experiments, but with a covered cell in the first one and with an opened cell in the second one. We recognized a small difference between the two experiments. In fact, the maximum of deflection was a little bit higher when the cell was covered. On the other hand, the decay of the signal was slower in this experiment. This indicates that the evaporation factor exists, and it is better to cover the cell to prevent the loss of heat by evaporation. This loss is a source of error, because it changes according to the surrounding conditions like temperature and humidity, and it changes according to the quantity of heat available in the upper phase.

But this factor is not sufficient to explain the difference between the experimental curve and the theoretical one. Another factor that might be the origin of this difference is the actual quantity of heat which propagates effectively from the upper phase to the lower one.

In fact, the aqueous phase is in contact with the monitoring phase and with the neighboring parts of the cell’s sides. So heat will propagate not only through the monitoring phase, but also through the neighboring parts of the cell’s sides. As quartz is thermally more conducting than  $\text{CCl}_4$  [7,14], the temperature of these parts of the cell’s sides becomes close to the temperature of the aqueous phase in a short period of time compared to the time of evolution of the system.

Let us calculate the rates of flow of heat  $\Phi$  in quartz and  $\text{CCl}_4$ : We know that  $\Phi$  satisfies the equation:  $\Phi = \vec{j}_Q \cdot \vec{S}$ , where  $\vec{S}$  is the surface vector cross section and  $\vec{j}_Q$  is the uniform heat flux density assumed uniform. On the other hand, we have:  $\vec{j}_Q = -\kappa \cdot \text{grad}T$  “Fourier law”,  $\kappa$  is the thermal conductivity. So, one can write:  $\Phi = -\kappa \cdot \vec{S} \cdot \text{grad}T$ .

The thermal conductivity of  $\text{CCl}_4$  is  $0.106 \text{ W m}^{-1} \text{ K}^{-1}$  [7], and the thermal conductivity of quartz is  $1.379 \text{ W m}^{-1} \text{ K}^{-1}$  [14] at  $T = 293 \text{ K}$ . On the other hand, the surface area of the horizontal section of the sides of the cell is  $0.44 \text{ cm}^2$  (as the side length of the inner square of the cell is 1 cm, and the side length of the outer square is 1.2 cm),

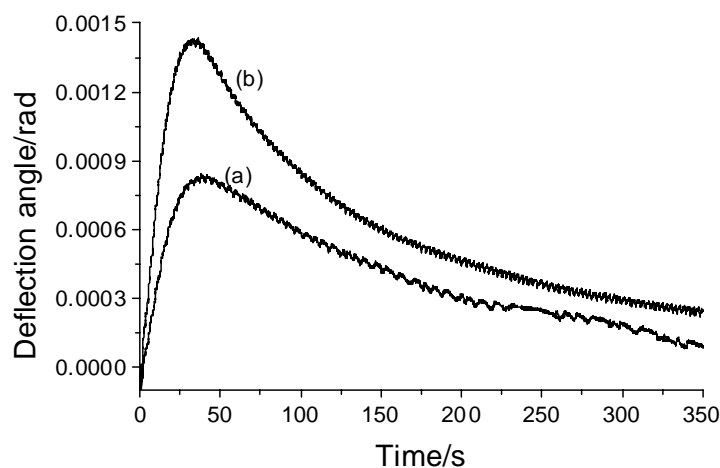

Fig. 7. Comparison between beam deflection signals (a) in quartz cell and (b) in plastic cell, using a high concentration sucrose solution as a monitoring phase.

and the water/ $\text{CCl}_4$  interface has a surface of  $1 \text{ cm}^2$ . So, if we calculate the ratio  $\Phi_{\text{CCl}_4}/\Phi_{\text{total}} = \Phi_{\text{CCl}_4}/(\Phi_{\text{CCl}_4} + \Phi_{\text{quartz}}) = \kappa_{\text{CCl}_4} S_{\text{CCl}_4}/(\kappa_{\text{CCl}_4} S_{\text{CCl}_4} + \kappa_{\text{quartz}} S_{\text{quartz}})$ , we find  $\Phi_{\text{CCl}_4}/\Phi_{\text{total}} \approx 1/6.7$  which is approximately the same factor between the theoretical and the experimental curves. This means that the rate of flow of heat through the sides of the cell is six times higher than through  $\text{CCl}_4$ :  $\Phi_{\text{quartz}}/\Phi_{\text{CCl}_4} \approx 5.7$ , and the main source of heat dissipation is the flow of heat through the sides of the cell. This will contribute consequently in decreasing the sensitivity of the device.

We insist here that the above calculation constitutes only an approximate estimation. We made the assumption that  $\text{grad}T$  is approximately the same in the monitoring phase and in the neighboring parts of the cell's sides. This assumption is justified by the low horizontal temperature gradient proven experimentally.

The above estimation shows that the principle factor which makes difference between experimental and theoretical deflection is due to the loss of heat in cell's sides. Schneider et al. [11] has attributed the weak beam deflection to heat propagation in all directions.

In order to prove experimentally the role of the cell nature in the loss of heat, we performed two identical experiments using two different cells: a quartz one and a plastic one (a polystyrene, PS cell). We used a high viscosity sucrose solution (50%, w/w) as a monitoring phase because  $\text{CCl}_4$  dissolves the plastic cell. As the thermal conductivity of the sucrose solution is  $0.454 \text{ W m}^{-1} \text{ K}^{-1}$  [15], and the thermal conductivity of the plastic cell is  $0.180 \text{ W m}^{-1} \text{ K}^{-1}$  [16], then the fraction of heat flow propagating through the sucrose solution in the plastic cell is:

$$\left( \frac{\Phi_{\text{sucrose}}}{\Phi_{\text{total}}} \right)_{\text{plastic}} = \frac{0.454 \times 1}{(0.454 \times 1) + (0.180 \times 0.44)} = 0.851$$

and the fraction of heat flux propagating through the sucrose solution in the quartz cell is:

$$\left( \frac{\Phi_{\text{sucrose}}}{\Phi_{\text{total}}} \right)_{\text{quartz}} = \frac{0.454 \times 1}{(0.454 \times 1) + (1.379 \times 0.44)} = 0.428$$

So, one would expect that the beam deflection in the plastic cell will be almost two times higher than the beam deflection in the quartz one. If we calculate from Fig. 7, the ratio of the maximum beam deflection in the plastic cell to that in the quartz one, we find it is approximately 1.7, which is in a reasonable agreement with the expected ratio. This experiment confirms the assumption of heat dissipation through the sides of the cell as a major factor that decreases the sensitivity of detection in this calorimeter.

Taking into account the effect of the nature of the cell in heat dissipation, it becomes possible to perfect this calorimeter by using a cell with a low thermal conductivity, allowing consequently a larger quantity of heat, available in the upper phase, to propagate to the lower one, and to induce a higher beam deflection. One can also perfect this calorimeter by using another solvent with a greater thermal conductivity than quartz, in the monitoring phase (this solvent must have a high thermo-optic coefficient and a greater density than water). This will permit to increase the sensitivity of the device, and consequently improve its heat limit of detection. We recall that HLOD is proportional to the blank standard deviation (almost constant in this calorimeter) and inversely proportional to the sensitivity [17].

## 7. Conclusion

In this work, we have investigated several factors that affect the detection sensitivity in an apparatus for heat measurements. In this apparatus, the heat liberated from a reaction in an upper phase propagates to a lower phase, where

a laser beam passes and deviates permitting the measurements. We proved that the flow of heat from the upper phase to the lower one is almost vertical. This result permits to use a model of one-dimensional heat propagation, and consequently to find origins of some imperfections of the apparatus, essentially the one due to the cell nature used. This work would permit to improve significantly the heat limit of detection.

## References

- [1] R. Hooke, *Micrographia*, J. Martyn & J. Allestry, London, 1665.
- [2] G.S. Settles, *Schlieren and Shadwgraph Techniques*, Springer-Verlag, Berlin, 2001.
- [3] A.C. Boccara, D. Fournier, J. Badoz, *Appl. Phys. Lett.* 36 (2) (1980) 130.
- [4] S.E. Bialkowski, *Photothermal Spectroscopy Methods for Chemical Analysis*, Wiley, New York, 1996.
- [5] J.C. Murphy, L.C. Aamodt, *J. Appl. Phys.* 51 (9) (1980) 4580.
- [6] J. Pawliszyn, F. Weber Michael, M.J. Dignam, R.D. Venter, S.-M. Park, *Anal. Chem.* 58 (1986) 236.
- [7] W.M. Rohsenow, J.P. Hartnett, Y.I. Cho, *Handbook of Heat Transfer*, 3rd ed., McGraw-Hill, New York, 1998.
- [8] X.-Z. Wu, H. Shindoh, M. Yamada, T. Hobo, *Anal. Chem.* 85 (1993) 834.
- [9] X.-Z. Wu, T. Hobo, *Anal. Chem. Acta* 316 (1995) 111.
- [10] X.-Z. Wu, T. Morikawa, K. Uchiyama, T. Hobo, *J. Phys. Chem.* 101 (1997) 1520.
- [11] T. Schneider, M.J. Politi, M.S. Baptista, *Thermochim. Acta* 362 (2000) 179.
- [12] S. Godounov, *Equations de la physique Mathématique*, Mir, Moscow, 1973.
- [13] C.L. Yaws, *Physical Properties*, McGraw-Hill, New York, 1977.
- [14] D.R. Lide, *Handbook of Chemistry and Physics*, 71st ed., CRC Press, Boca Raton, 1990–1991.
- [15] Z. Bubnik, P. Kadlek, D. Urban, M. Bruhns, *Sugar Technologists Manual: Chemical and Physical Data for Sugar Manufacturers and Users*, Bartens, Berlin, 1995.
- [16] H. Domininghaus, *Plastics for Engineers: Materials, Properties, Applications*, Hanser, Munich, 1993.
- [17] Eurachem Working Group, *The Fitness for Purpose of Analytical Methods*, LGC, Teddington, U.K., 1998.