

# Development of biocalorimetry as a technique for process monitoring and control in technical scale fermentations

Mustafa Türker\*

*Pakmaya, P.O. Box 149, İzmit, 41001 Kocaeli, Turkey*

Available online 1 April 2004

## Abstract

Quantitative calorimetry has been developed in a production scale bioreactor with a volume of 100 m<sup>3</sup>, using continuous and dynamic methods that require a heat balance be developed around the bioreactor. In order to measure the components of heat balance accurately, the precise measurements of all temperatures and flows were installed in the bioreactor. The on-line measurements of these terms then permitted the on-line calculation of metabolic heat flux from general energy balance in Eq. (1). Good correlation was obtained between oxygen uptake (OUR) and metabolic heat production rates both in continuous and dynamic methods. The metabolic heat production was also estimated from heats of combustion of substrate, biomass and ethanol and compared with experimentally measured values and good correlation was obtained. Biomass concentration was estimated from elemental, electron and heat balances and reasonable estimation have been performed using heat balance calorimetry. Direct relation has been found between cooling water flow rate and metabolic heat flux that simplifies monitoring microbial activity in large-scale fermentations. Dynamic method also allowed quick and practical estimation of overall heat transfer coefficient in the heat exchanger and reduction in the coefficient due to fouling on the surfaces of the plates could easily be identified. The results of this study suggest that quantitative calorimetry in a production scale bioreactor can be simplified by accurately identifying individual heat sources and can be realised using simple instrumentation as compared to the sensors currently used in industry.

© 2004 Elsevier B.V. All rights reserved.

*Keywords:* Biocalorimetry; Macrocalorimetry; Baker's yeast; Fed-batch; Bioprocess monitoring

## 1. Introduction

There are basically two methods to measure heat effects in microbial processes; in the first approach, calorimetric devices specially constructed for this purpose called microcalorimeters were used by many researchers to study thermodynamics of many bioreactions. Microcalorimeters were developed first and reached sufficient sensitivity for biological process monitoring. However, this approach suffers from the disadvantage that the environment for the micro-organism in which the metabolic heat is measured, is different from the environment in which the process takes place. This problem has been resolved by the advent of bench-scale calorimeters. They have been used in quantitative studies on microbial growth and product formation. In the second approach, the metabolic heat production is measured in the bioreactor itself to eliminate the problems encountered in microcalorimetric measuring devices [1,2].

Cooney and co-workers [3–5] have refined this approach in laboratory bioreactors, called discontinuous method. In this method, the temperature control system was inactivated at intervals and the temperature of the broth was allowed to rise. The rate of heat production then was calculated from the slope of temperature–time curve by using overall energy balance set-up around the bioreactor. van Kleeff et al. [6] have introduced heat balance calorimetry using complete energy balance without the need for inactivating the cooling system. Voisard et al. [7] have applied heat balance calorimetry to 300 l mid-scale bioreactor in which fed-batch production of *Bacillus sphaericus* was carried out. They have taken into account all heat flows entering and leaving the bioreactor.

Heat effect in microbial reactions are not obvious when using laboratory bioreactors since most of heat is lost to environment to give noticeable increase in temperature of broth, due to high surface to volume ratio. The situation is completely different in industrial-size bioreactors. The production scale bioreactors operates nearly adiabatically due to much lower surface to volume ratio compared to laboratory-scale bioreactors. These reactors can be considered as a form of calorimeter. The generation of metabolic

\* Tel.: +90-262-321-44-51; fax: +90-262-321-81-17.

*E-mail address:* [mustafat@pakmaya.com.tr](mailto:mustafat@pakmaya.com.tr) (M. Türker).

**Nomenclature**

$A$	area (m <sup>2</sup> )
$c_p$	heat capacity (kJ/(kg °C))
$C$	concentration of water in air (kg/m <sup>3</sup> )
$F_i$	flow rate of $i$ (m <sup>3</sup> /h)
$h_i$	heat transfer coefficient of $i$ (W/(m <sup>2</sup> °C))
$\Delta H_i$	heat of combustion of $i$ (kJ/kg)
$M_i$	molecular weight of $i$ (g/mol)
$M_x$	total biomass in the bioreactor (kg)
OUR	oxygen uptake rate (kg O <sub>2</sub> /(m <sup>3</sup> h))
$P_i$	partial pressure of $i$ (atm)
$q$	total heat (kJ/h)
$Q$	heat (kJ/m <sup>3</sup> )
$r_i$	rate of consumption or production of $i$ (kg/(m <sup>3</sup> h))
$r_Q$	volumetric heat production rate (kJ/(m <sup>3</sup> h))
$T$	temperature (°C)
$U$	overall heat transfer coefficient (W/(m <sup>2</sup> °C))
$V$	volume (m <sup>3</sup> )
$X$	biomass concentration (kg/m <sup>3</sup> )
$Y_{i/j}$	yield of $i$ over $j$
$Y_{Q/X}$	heat yield (kJ/kg)

**Greek letters**

$\gamma$	degree of reduction of $i$
$\varepsilon$	emissivity
$\mu$	specific growth rate (h <sup>-1</sup> )
$\rho$	density of $i$ (kg/m <sup>3</sup> )
$\sigma$	constant (W/(m <sup>2</sup> K <sup>4</sup> ))

**Subscripts**

a	acid
b	broth
exch	exchanger
f	bioreactor
in	inlet
m	molasses
max	maximum
n	nitrogen
ox	oxidative
out	outlet
p	product
red	reductive
s	substrate
sur	surface of bioreactor
surr	surrounding
w	water
x	biomass

heat encountered in large-scale bioreactors can indeed be so significant that, ensuring the corresponding surface area for temperature control may be a real technical challenge. One example is the process developed in 1970s by ICI in Great

Britain. In this process, it has been reported that hourly metabolic heat generation could reach up to 300,000 MJ during growth of bacteria on methanol in continuous single cell protein production process [8]. French scientist Dubrunfaut [9], who was rightly called a father of modern macrocalorimetry, carried out a first experiment with microbial systems in a large scale in the middle of the 19th century. He made a one essential experiment in 1856 to determine the heat production accompanying alcoholic fermentation. Molasses solution of 21,400 l containing 2559 kg of sugar was used in a huge vat of 3 m diameter and height. During the 4 days of fermentation the broth temperature rose from 23.7 to 33.7 °C. Dubrunfaut calculated the loss of heat due to radiation and convection by measuring the rate at which the vat was cooled after fermentation had ceased. Moreover, he took into account heat storage in the vat, evaporation and stripping of CO<sub>2</sub> from the solution into atmosphere. Recently, heat balance calorimetry was applied for the first time in a production scale bioreactor [10]. All heat flows entering and leaving the bioreactor were quantified by measuring necessary flows and temperatures and metabolic heat generated was calculated from relevant information obtained from overall energy balance.

**2. Theory****2.1. General energy balance**

The schematic layout of the bioreactor is shown in Fig. 1, where main components of the bioreactor are illustrated. The general dynamic heat balance around the industrial bioreactor can be written as follows:

$$\rho c_{p,b} \frac{d(VT)}{dt} = q_{\text{feed}} + q_{\text{metabolic}} + q_{\text{mechanic}} + q_{\text{exchanger}} + q_{\text{surface}} + q_{\text{evaporation}} + q_{\text{radiation}} + q_{\text{acid}} + q_{\text{CO}_2} \quad (1)$$

The contributions of each term in Eq. (1) were calculated using equations in Table 1. In the present work, including the terms representing the energy removed by CO<sub>2</sub> stripping and energy generated by acid dilution and neutralisation has

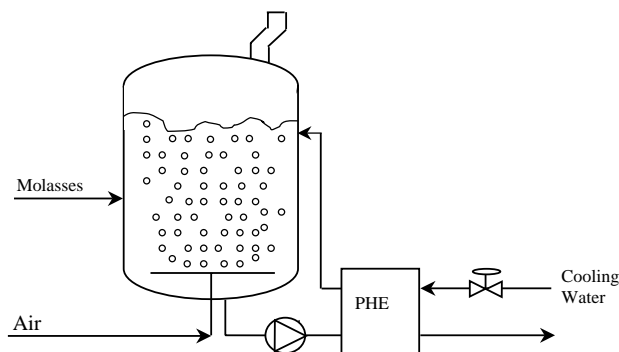

Fig. 1. The layout of the bioreactor for which energy balance has been established.

Table 1  
Quantification of energy sources coming to and leaving bioreactor

Feed	$q_{\text{feed}} = \sum_{i=1}^n F_i \rho_i c_{p,i} (T_i - T_f) = F_m c_{p,m} (T_m - T_f) + F_{\text{air}} \rho_{\text{air}} c_{p,\text{air}} (T_{\text{air}} - T_f)$
Metabolic	$q_{\text{metabolic}} = r_Q V_L$
Exchanger	$q_{\text{exchanger}} = U_{\text{exch}} A_{\text{exch}} \Delta \bar{T}_L = F_w c_{p,w} (T_{\text{in}} - T_{\text{out}})$
Surface	$q_{\text{surface}} = h_{\text{air}} A_{\text{sur}} (T_{\text{broth}} - T_{\text{surr}})$
Evaporation	$q_{\text{evaporation}} = F_{\text{air}} \Delta H_w^{\circ} (P_w^{\text{out}} - P_w^{\text{in}})$
Radiation	$q_{\text{radiation}} = A_{\text{sur}} \varepsilon \sigma (T_f^4 - T_{\text{surr}}^4)$
Acid dilution and neutralisation	$q_{\text{acid}} = F_a \Delta H_d + F_a \Delta H_r$
CO <sub>2</sub> stripping	$q_{\text{CO}_2} = F_c \Delta H_{\text{CO}_2}$

refined the model presented in the previous article [10]. During fermentations, CO<sub>2</sub> is produced and if the fermentation is carried out at lower pH values CO<sub>2</sub> formed is continuously stripped through aeration. Release of CO<sub>2</sub> from the medium is an endothermic reaction [11] according to:



Acid used during fermentation for pH control will yield heat effect when added to the fermenter. Voisard et al. [7] have reported that  $\Delta H_d = 4 \text{ kJ/mol}$  proton was estimated when sulphuric acid was used for pH control. Moreover, added protons will be neutralised and generate heat according to following reaction [7,11]:

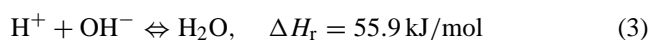

The general energy balance can be written in explicit form as follows:

$$\begin{aligned} \rho_b c_{p,b} \frac{d(VT)}{dt} = & F_m \rho_m c_{p,m} (T_m - T_f) \\ & + F_{\text{air}} \rho_{\text{air}} c_{p,\text{air}} (T_{\text{air}} - T_f) + F_a (\Delta H_d + \Delta H_r) \\ & + r_Q V_L - U_{\text{exch}} A_{\text{exch}} \Delta \bar{T}_L \\ & - U_{\text{sur}} A_{\text{sur}} (T_f - T_{\text{surr}}) \\ & - F_{\text{air}} \Delta H_w^{\circ} (P_w^{\text{out}} - P_w^{\text{in}}) \\ & - A_{\text{sur}} \varepsilon \sigma (T_f^4 - T_{\text{surr}}^4) - F_c \Delta H_{\text{CO}_2} \quad (4) \end{aligned}$$

In continuous experiments, Eq. (4) are equal to zero, since the accumulation term is zero due to temperature control at set point. Then, metabolic heat is calculated from Eq. (4) since other heat sources can be calculated from experimentally measured temperature flow information.

In dynamic experiments, the rate of metabolic heat generation at any time is estimated using dynamic energy balance since heat transfer through heat exchanger is eliminated whereas other heat transfer mechanisms are still taken into account:

$$\begin{aligned} \rho_b c_{p,b} \frac{d(VT)}{dt} = & F_m \rho_m c_{p,m} (T_m - T_f) \\ & + F_{\text{air}} \rho_{\text{air}} c_{p,\text{air}} (T_{\text{air}} - T_f) + F_a (\Delta H_d + \Delta H_r) \\ & + r_Q V_L - U_{\text{sur}} A_{\text{sur}} (T_f - T_{\text{surr}}) \\ & - F_{\text{air}} \Delta H_w^{\circ} (C_w^{\text{out}} - C_w^{\text{in}}) \\ & - A_{\text{sur}} \varepsilon \sigma (T_f^4 - T_{\text{surr}}^4) - F_c \Delta H_{\text{CO}_2} \quad (5) \end{aligned}$$

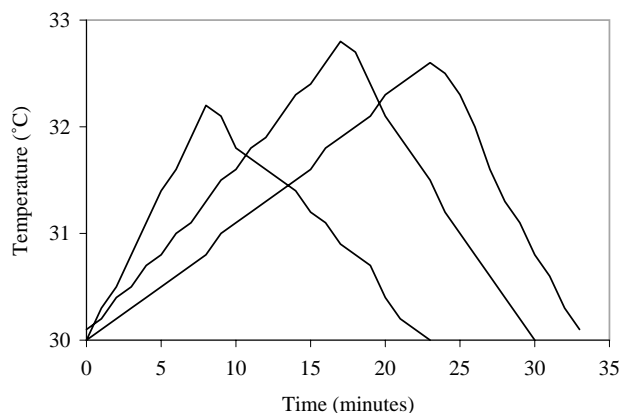
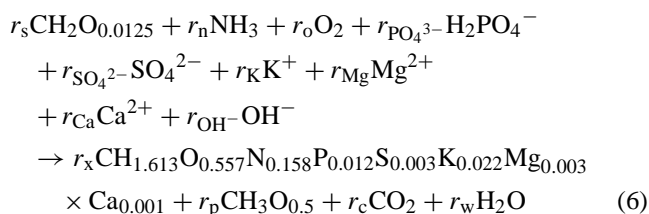

Fig. 2. Temperature curves in dynamic experiments at different heat production rates during fermentation. The magnitude of the slopes of each curve is directly related to the magnitude of rate of metabolic heat production. Similarly the slopes of the cooling periods also indicate the capacity of heat exchanger to bring the temperature down to its set value. In this work, it is slightly exaggerated and the broth temperature is allowed to increase more than 2 °C. However, 0.5 °C would be enough to get the rate of heat production.

Cooling system was deliberately inactivated at certain time and rate of temperature rise (or slope) was a function of metabolic heat production rate as shown in Fig. 2.

## 2.2. Process stoichiometry, elemental, electron and heat balances

Overall growth equation given below is based on Battley [12]. The coefficient of ethanol in the equation is either positive if ethanol is produced, or negative if ethanol is consumed:



The cell composition in Eq. (6) is given by Battley [12], based on comprehensive analysis of compressed baker's yeast, which represents 99.97% of "whole cells". Ion containing unit carbon formula weight of the cells is 26.202 g/(C mol) and the number of available electrons to be transferred to oxygen upon complete oxidation of whole cells is 4.079 electrons/(C mol) according to following combustion reaction:

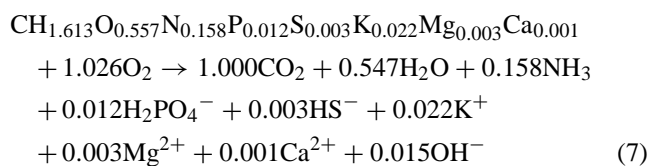

Heat balance can be written as:

$$r_s \Delta H_s^* = r_x \Delta H_x^* + r_p \Delta H_p^* + r_Q \quad (8)$$

Elemental balances can be written from Eq. (6) as follows:

$$C: r_s = r_x + r_p + r_c \quad (9)$$

$$N: 0.0125r_s + r_n = 0.158r_x \quad (10)$$

The degree of reduction balance:

$$\gamma_s r_s - 4r_o = \gamma_x r_x + \gamma_p r_p \quad (11)$$

### 3. Materials and methods

The fed-batch fermentations of yeasts were carried out in an industrial-scale bioreactor with a volume of 100 m<sup>3</sup> as shown in Fig. 1, using industrial strain of *Saccharomyces cerevisiae*. In continuous experiments, data were collected every 15 min along the fermentation whereas in dynamic experiments temperature shift-up was performed when necessary. The bioreactor was equipped with external plate heat exchanger for cooling. Carbon source and nitrogen sources were fed according to a predetermined feeding schedule using magnetic flow meters (Krohne). Air flow rate was measured by vortex flow meter (Emco V-Bar). Temperatures of inlet air and molasses were measured together with their flow rates to calculate their sensible heats with respect to broth temperature. Oxygen and CO<sub>2</sub> in exhaust gas were measured by Servomex gas analyser (1400B4 SPX) and oxygen uptake rate (OUR) was calculated using inert gas balance. A polarographic pO<sub>2</sub> probe (Ingold) monitored the dissolved O<sub>2</sub> concentration. The temperature of broth was maintained at desired value by recirculating the broth through external plate heat exchanger equipped with temperature probes at all inlets and outlets. The flow rate of cooling water was measured using Krohne Aquaflux flow meter and quantity of heat removed through heat exchanger was calculated using

temperature flow rate information. Heat lost to environment from the surface of bioreactor through convection and radiation were calculated using equations in Table 1. Evaporative heat loss was calculated by measuring humidity of inlet air. Humidity of exhaust gas was assumed to be saturated at broth temperature. Experimental details are same as in [10].

## 4. Results and discussion

### 4.1. Quantification of major heat sources

The substrate molasses was added to the bioreactor initially at exponential rate equal to maximum oxidative specific growth rate then at constant feeding to maintain oxidative growth conditions, corresponding to maximum oxygen transfer rate as shown in Fig. 3. During exponential growth, the dissolved oxygen concentration was high and gradually decreased to low levels whereafter remained close to zero. The validity of oxidative growth conditions was verified by calculating respiratory quotient (RQ) from exhaust gas analysis and measuring alcohol content of the broth. The respiratory quotient remained close to one along the fermentation indicating that oxidative growth conditions were maintained.

The cumulative quantities of heat coming to and from the system were calculated from on-line temperature and flow rate information. These are the sensible heats of incoming streams, namely compressed air, hot molasses solution, acid addition and dilution and metabolic heat production. The sensible heats of incoming streams and metabolic heat generated during fermentation were removed by surface cooling, radiation, evaporation and heat exchanger. The rate of metabolic heat production was obtained from overall energy balance in Eq. (1). The cumulative quantities of heat flows to and from the bioreactor are presented in Fig. 4a and b along the fermentation. Overall, metabolic heat production constitutes 88.3% of the overall heat coming to the system.

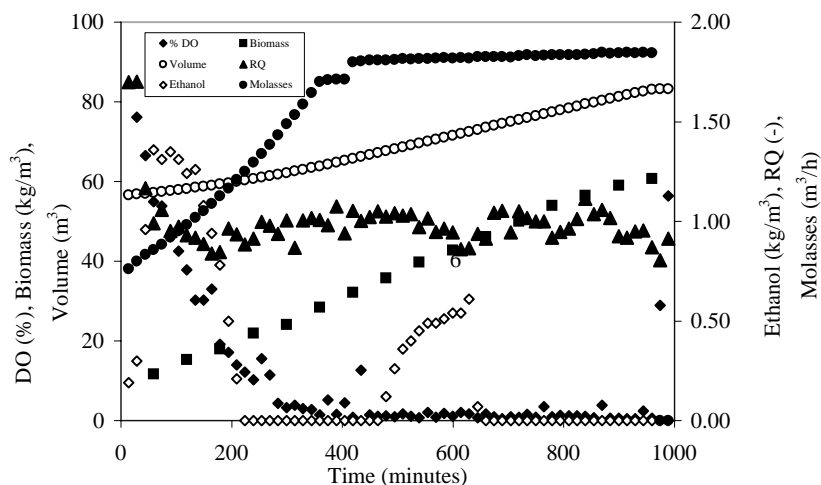

Fig. 3. Experimental results of typical fed-batch fermentation.

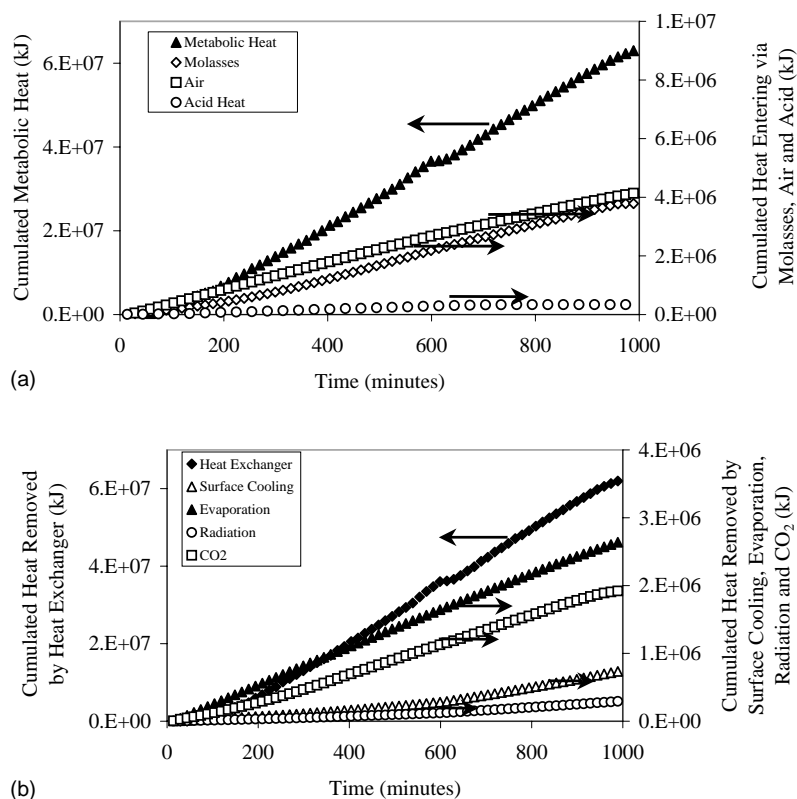

Fig. 4. (a) Cumulative quantities of heat coming to the bioreactor with feeding of substrate, air, metabolic heat and acid dilution and neutralisation. (b) Cumulative quantities of heat leaving bioreactor with heat exchanger, surface cooling radiation, evaporation and stripping of CO<sub>2</sub>.

The compressed air carries 5.9% of the total heat load and the rest 5.3% carried to the system by hot molasses solution. The contribution of acid dilution and neutralisation is 0.5% of total heat entering to the system. On the other hand, the major mechanism of heat removal is through heat exchanger and 91.7% of the total heat is removed through this mechanism. The heat removed through surface cooling (radiation and natural convection) constitutes only together 1.5% of the total. The evaporative cooling effect is relatively high compared to the surface effects and second to the heat removed by heat exchanger and 3.9% of the total heat load is removed by this way. Meier-Schneiders et al. [11] proposed that stripping of CO<sub>2</sub> from broth absorb heat that should be considered in overall energy balance. We calculated the heat for desorption of CO<sub>2</sub> from broth as shown in Fig 4b and it constitutes 2.8% of overall heat load and relatively higher than surface effects. These results clearly illustrate the benefits of heat flux measurements in large-scale bioreactors due to relatively low contribution of surface effects. This benefit becomes more pronounced as the size of reactor and volumetric production rates increase.

#### 4.2. Oxygen consumption and metabolic heat production

Oxygen uptake rate along the fermentation has been calculated using inert gas balance from Eq. (12) in continuous and dynamic experiments and plotted in Fig. 5a and b,

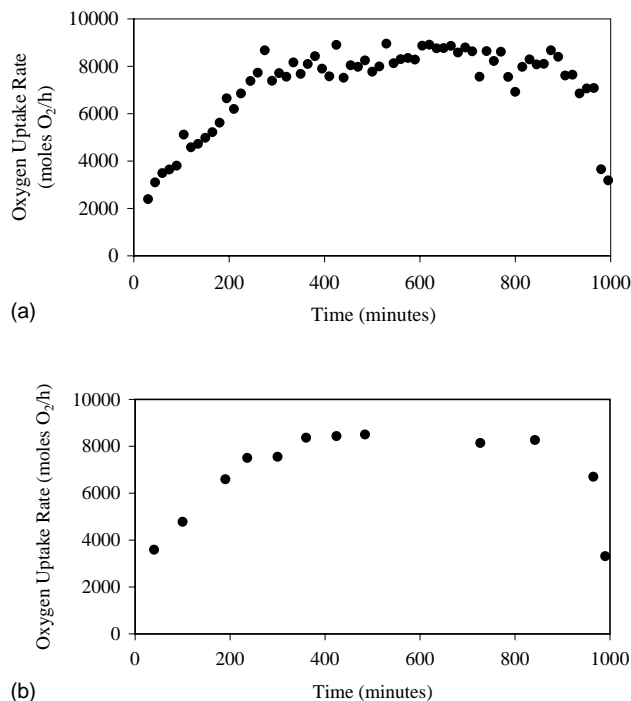

Fig. 5. Oxygen uptake rates obtained in continuous (a) and dynamic (b) experiments. Trends in these figures closely follow the trends in substrate feeding and metabolic heat production rates.

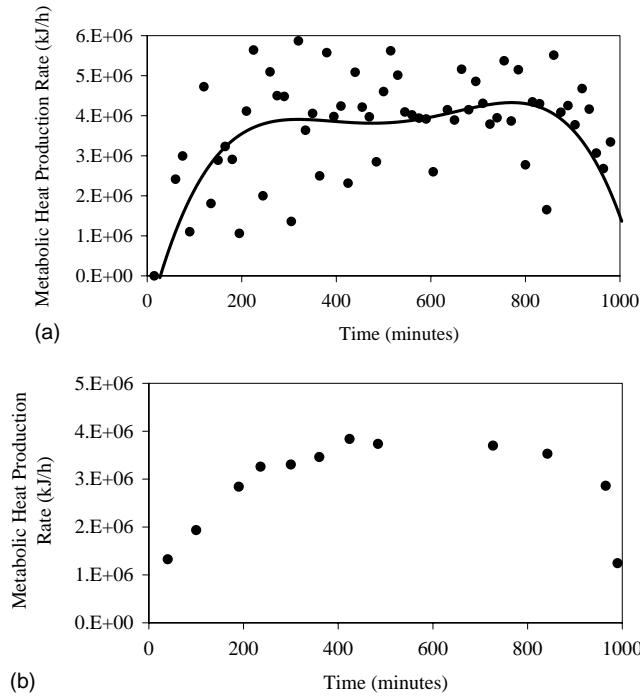

Fig. 6. Metabolic heat production rates obtained in continuous (a) and dynamic (b) experiments.

respectively. Oxygen consumption rate first increased from 2000 to 8000 mol O<sub>2</sub> then remained constant during the rest of the fermentation in concomitant with substrate feeding rate:

$$\text{OUR} = \frac{F_N}{V} \left[ \frac{P_{\text{O}_2}^{\text{in}}}{1 - P_{\text{O}_2}^{\text{in}} - P_{\text{CO}_2}^{\text{in}} - P_{\text{w}}^{\text{in}}} - \frac{P_{\text{O}_2}^{\text{out}}}{1 - P_{\text{O}_2}^{\text{out}} - P_{\text{CO}_2}^{\text{out}} - P_{\text{w}}^{\text{out}}} \right] \quad (12)$$

Total heat production rates were measured by both continuous and dynamic calorimetry and presented in Fig. 6a and b. The data obtained in continuous experiments gives scatter, therefore polynomial was fit to get better trend as shown by continuous line. In average, both methods give same trend and total metabolic heat production rates reach to 4,000,000 kJ/h. Trends in these figures closely follow the trends in substrate feeding and oxygen consumption rates. Similar values with much lower scatter were obtained in dynamic experiments as shown in Fig. 6b. Metabolic heat production rates also follow same trends as oxygen uptake rates.

The correlation between heat generation and oxygen uptake was studied both in continuous and dynamic experiments and cumulative oxygen uptake versus metabolic heat production are plotted in Fig. 7a and b. From the slopes of Fig. 7a and b, heat yield on oxygen,  $Y_{Q/O}$ , were found to be 440 and 432 kJ/mol O<sub>2</sub> for continuous and dynamic experiments, respectively.

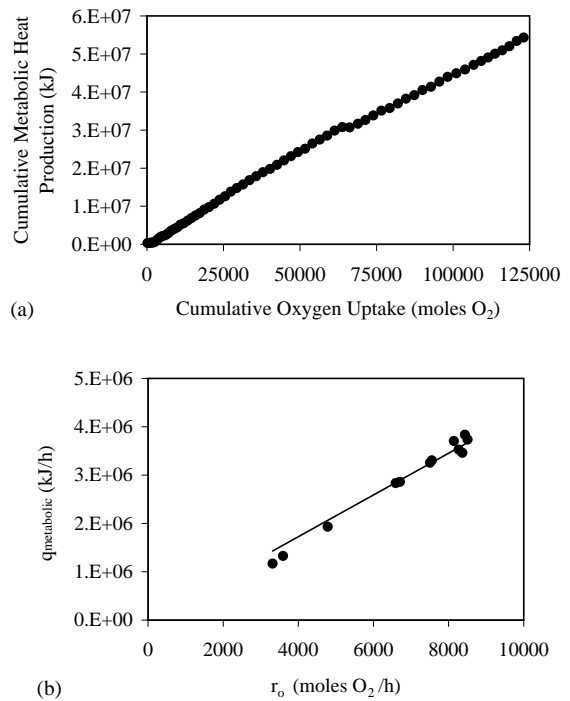

Fig. 7. Metabolic heat production vs. oxygen consumption in continuous (a) and dynamic (b) experiments. The slopes in each figure give heat yields on oxygen,  $Y_{Q/O}$ .

#### 4.3. Quantitative estimation of metabolic heat from enthalpy balance

Heat of reaction can be written in terms of heats of combustion of compounds in stoichiometric Eq. (6) as:

$$r_Q = r_s \Delta H_s^* - r_x \Delta H_x^* - r_p \Delta H_p^* \quad (13)$$

where  $\Delta H_i^*$  is heat of combustion of component  $i$  with respect to CO<sub>2</sub> and NH<sub>3</sub> reference points. Heats of combustion of glucose, ethanol and yeast cells are given in Table 2.

Heat of combustion of biomass has been subject to discussion in the literature. Duboc et al. [13] have collected and organised large number of data and found that heats of combustion of biomass may differ for different organisms, strains and growth conditions. Then, Eq. (13) can be written as to account for metabolic heat released from Hess' law:

$$r_Q = 467.8r_s - 463.9r_x - 684.5r_p \quad (14)$$

where  $r_Q$  can be calculated from Eq. (14) if  $r_s$ ,  $r_x$  and  $r_p$  are available. Cumulative quantities of experimentally measured metabolic heats are plotted in Fig. 8 together with

Table 2  
Heats of combustion of glucose, ethanol and yeast cell material [12]

	$\Delta H_i^*$ (kJ/(C mol))	$\Delta H_i^*$ (kJ/(e mol))
Glucose	477.02	119.26
Ethanol	684.5	113.48
Yeast cell material	463.86	113.72

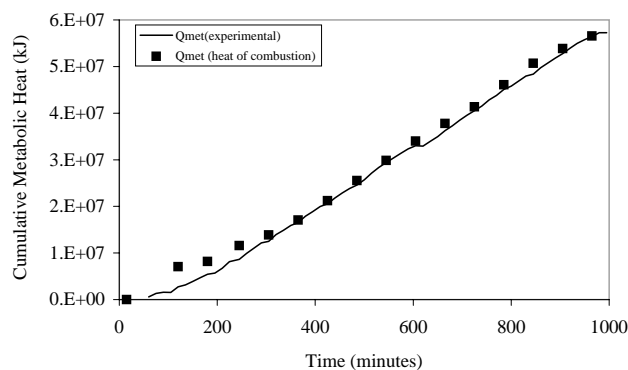

Fig. 8. The quantitative estimation of metabolic heat using heats of combustion of the compounds in the stoichiometric equation (squares) and its comparison with the experimentally measured metabolic heat (continuous line).

the quantities estimated from Eq. (14) which gives reasonably good estimation of experimental metabolic heat production rates as long as material flows ( $r_i$ ) are accurately known.

The rate of metabolic heat generation can be related to growth with following equation and results are shown in Fig. 9:

$$q_{\text{metabolic}} = Y_{Q/X} \mu M_x + m M_x \quad (15)$$

The direct relation is clearly seen between metabolic heat production rate and growth rate of the micro-organism. Therefore, the heat yield on biomass  $Y_{Q/X}$ , is estimated to be 15,290 kJ/kg from the slope of Fig. 9.

#### 4.4. Estimation of biomass concentration using heat, elemental and electron balances

If a rate of heat production ( $dq_{\text{metabolic}}$  (kJ)) over a chosen time period ( $dt$ ) divided by heat yield ( $Y_{Q/X}$ ) gives biomass produced for the time period ( $dt$ ):

$$dM_x = \frac{dq_{\text{metabolic}}}{Y_{Q/X}} \quad (16)$$

Therefore, biomass concentration can be estimated by integrating measured metabolic heat generation over a chosen

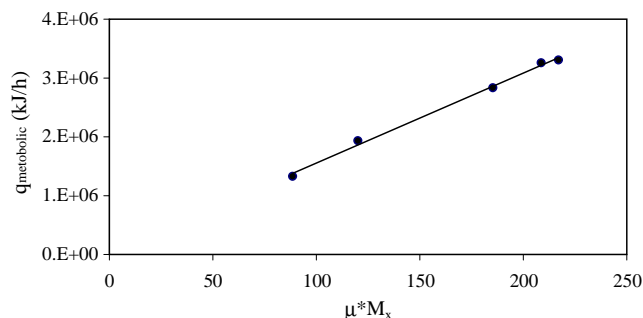

Fig. 9. Metabolic heat production rate vs. growth rate of micro-organism.

period of time as (since  $M_x(t) = V(t) X(t)$ ):

$$M_x(t) = \frac{1}{Y_{Q/X}} \int dq_{\text{metabolic}} \quad (17)$$

$$M_x(t) = M_{x,0} + \int dM_x \quad (18)$$

$$X(t) = \frac{M_x(t)}{V(t)} \quad (19)$$

where  $M_{x,0}$  is the amount of seed yeast and  $Y_{Q/X}$  was already determined as 14,539 kJ/kg biomass [10].

The biomass concentration can also be estimated from elemental and electron balances. The rate of biomass formation can be calculated from carbon balances using on-line measurement of substrate addition and  $\text{CO}_2$  and ethanol production as follows:

$$r_x = r_s - r_p - r_c \quad (20)$$

Nitrogen and electron balances can be written, respectively, as:

$$r_x = \frac{1}{0.158} (r_n + 0.0125 r_s) \quad (21)$$

$$r_x = \frac{1}{\gamma_x} (\gamma_s r_s - 4 r_o - \gamma_p r_p) \quad (22)$$

Once the rate of biomass formation is calculated from relevant on-line measurements, the biomass concentration can be estimated by integrating the rate information over a time period as:

$$r_x V(t) = \frac{dV(t) X(t)}{dt} \quad (23)$$

$$X(t) = \frac{V_0 X_0}{V(t)} + \frac{1}{V(t)} \int r_x V(t) dt \quad (24)$$

The estimated biomass concentrations obtained from heat, elemental and electron balances are shown in Fig. 10 together with experimentally determined biomass concentrations. The correlation between estimated and measured

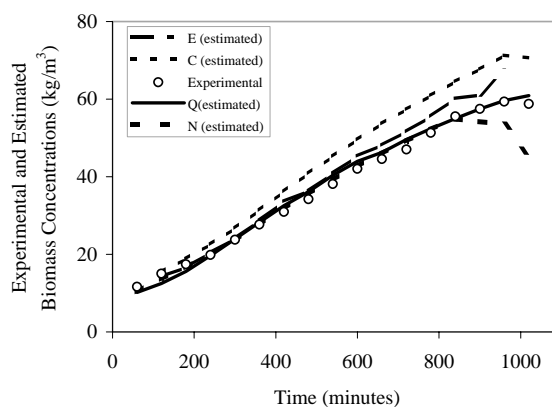

Fig. 10. Estimation of biomass concentration using elemental (carbon and nitrogen), electron and heat balances and their comparisons with experimental data.

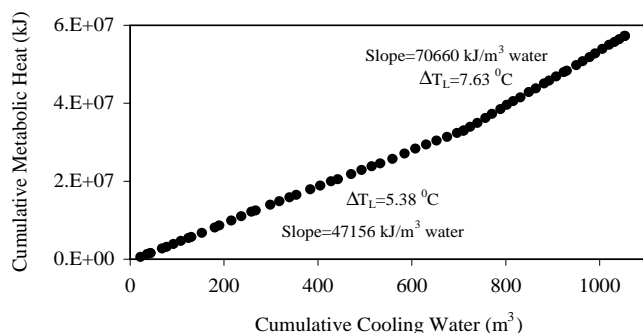

Fig. 11. Metabolic heat correlated with cooling water flow at two different logarithmic temperature differences.

biomass concentrations is quite reasonable, especially with heat flux measurements compared to those obtained with carbon and electron balances. When only nitrogen balance was used, biomass concentration was estimated only from nitrogen feeding since all nitrogen was assumed to be incorporated into biomass according to Eq. (21). However, this assumption may not be true due to nitrogen accumulation in the medium since nitrogen uptake is direct function of specific growth rate. Therefore, nitrogen balance should be used together with carbon balance for the estimation of biomass concentration.

#### 4.5. Correlation between metabolic heat and cooling water flow rate

Metabolic heat generation versus cooling water consumption has been plotted in Fig. 11. Linear correlation is clearly seen from the figure with two slopes both with different logarithmic temperature differences. By simply measuring cooling water flow rate, metabolic heat generation as a result microbial activity can be monitored.

#### 4.6. Determination of overall heat transfer coefficient of the heat exchanger in dynamic experiments

The overall heat transfer coefficient of heat exchanger can easily be determined from single dynamic experiment using overall energy balance. During the cooling period of the dynamic experiment, the energy balance around heat exchanger reads as:

$$F_w c_{p,w} (T_i - T_o) = U_{\text{exch}} A_{\text{exch}} \Delta \bar{T}_L \quad (25)$$

Since all parameters other than overall heat transfer coefficient are measured or known, the overall heat transfer coefficient,  $U_{\text{exch}}$ , can be calculated from Eq. (25). The experiments are carried out both when the exchanger is clean and after 6 months of service. The numerical values of the overall heat transfer coefficients measured both under dynamic conditions are given in Table 3. The clean heat transfer coefficient is approximately 3500 W/(m<sup>2</sup> °C) close to the values declared by manufacturers. Whereas after 6 months of service, water side gets dirty due to the formation

Table 3

Overall heat transfer coefficient at different experimental conditions (average of two different sets of experiments)

Condition	$U_{\text{exch}}$ (W/(m <sup>2</sup> °C))
Clean	3384 ± 178
Dirty (6 months later)	2890 ± 130

of scales and as a result, the value of overall heat transfer coefficient drops approximately 15%.

## 5. Conclusion

In the present work, energy balance has been established around production scale bioreactor to account for all heat flows to and from the bioreactor. From this information, rate of metabolic heat has been calculated and correlations have been established between various process variables. Major heat source was metabolic heat generated during microbial growth amounting to 88.3% of total heat load. The heat generated during fermentation is dissipated through various cooling mechanisms, all of which were evaluated to identify their contributions. Major cooling mechanism was the removal of heat through heat exchanger and 91.7% of total heat load was removed by this mechanism. In addition, taking into account heat effects of acid dilution and carbon dioxide stripping refined the model presented in the previous work [10]. It seems the energy required for CO<sub>2</sub> stripping should be included in the model to improve the accuracy, however, heat effect of acid dilution is not that significant although it depends on acid required for pH control in each fermentation. Similar results were obtained both with continuous and dynamic methods for heat production rates and oxygen consumption rates. In dynamic method, small temperature increase can be deliberately induced without altering culture characteristics. It has also been shown here that metabolic heat could be estimated from heats of combustion of the compounds in the stoichiometric equation.

Biomass concentration is a key variable in fermentations that need to be estimated to monitor physiological status of culture. Here, an attempt has been made to estimate biomass concentration using elemental, electron and heat balances. Heat balance has given quite good accuracy in estimating biomass concentration compared to elemental and electron balances. In nitrogen balance, biomass concentration is estimated only from nitrogen feeding since all nitrogen is assumed to be incorporated into biomass. However, nitrogen accumulation and formation of by product ethanol may result in overestimation of biomass concentration. It was also shown here that direct relation between cooling water consumption and metabolic heat generation as a function of logarithmic temperature difference. That means monitoring only cooling water flow will give important insight into the activity of cells in the bioreactor.



It may be concluded that it is possible to apply quantitative calorimetry in technical scale fermentations for on-line monitoring and control of bioreactions. In order to achieve this, simple measurement devices are necessary: temperature probes and flow meters. As a result, the cost and reliability of sensors used in calorimetry could be competitive when compared to other on-line monitoring techniques used in industrial environment. Although calorimetry has been subject to intensive research in small scale, its application in large scale is not available yet. It has a big potential in monitoring complex fermentations where existing techniques have shortcomings such as fermentations using solid substrates and complex composting processes.

### Acknowledgements

I am grateful to E. Tuller, H. Kapucu, A. Hocalar and plant personnel for their technical assistance.

### References

- [1] E.H. Battley, *Energetics of Microbial Growth*, Wiley, New York, 1987, p. 290.
- [2] U. von Stockar, I.W. Marison, The use of calorimetry in biotechnology, *Adv. Biochem. Eng. Biotechnol.* 40 (1989) 93–136.
- [3] C.L. Cooney, D.I.C. Wang, R.I. Mateles, Measurement of heat evolution and correlation with oxygen consumption during microbial growth, *Biotechnol. Bioeng.* 11 (1968) 269–281.
- [4] D.G. Mou, C.L. Cooney, Application of dynamic calorimetry for monitoring fermentation processes, *Biotechnol. Bioeng.* 18 (1976) 1371–1392.
- [5] H. Wang, D.I.C. Wang, C.L. Cooney, The application of dynamic calorimetry for monitoring growth of *Saccharomyces cerevisiae*, *Eur. J. Appl. Microb.* 5 (1978) 207–214.
- [6] B.H.A. van Kleeff, J.G. Kuenen, J.J. Heijnen, Continuous measurement of microbial heat production in laboratory fermentors, *Biotechnol. Bioeng.* 41 (1993) 541–549.
- [7] D. Voisard, P. Pugeaud, A.R. Kumar, K. Jenny, K. Jayaraman, I.W. Marison, U. von Stockar, Development of a large scale biocalorimeter to monitor and control bioprocesses, *Biotechnol. Bioeng.* 80 (2) (2002) 125–138.
- [8] U. von Stockar, I.W. Marison, Large scale calorimetry and biotechnology, *Thermochim. Acta* 193 (1991) 215–242.
- [9] M. Dubrunfaut, Note sur la chaleur et la travail mécanique produit par la fermentation vineuse, *C. R. Hebd. Séances Acad. Sci.* 42 (1856) 945–948.
- [10] M. Türker, Measurement of metabolic heat in a production scale bioreactor by continuous and dynamic calorimetry, *Chem. Eng. Commun.* 190 (2003) 573–598.
- [11] M. Meier-Schneiders, F. Schafer, U. Grosshans, C. Busch, Impact of carbon dioxide evolution on the calorimetric monitoring of fermentations, 251 (1995) 85–97.
- [12] E.H. Battley, The development of direct and indirect methods for the study of the thermodynamics of microbial growth, *Thermochim. Acta* 309 (1998) 17–37.
- [13] P. Duboc, I. Marison, U. von Stockar, Quantitative calorimetry and biochemical engineering, in: R.B. Kemp (Ed.), *Handbook of Thermal Analysis and Calorimetry*, vol. 4, Elsevier, 1999.