

# Cure of polyester resin in a cylindrical mould heated by air

Vanja Kosar\*, Zoran Gomzi, Sanda Antunović

*Department of Reaction Engineering and Catalysis, Faculty of Chemical Engineering and Technology,  
University of Zagreb, Savska c. 16, HR-10000 Zagreb, Croatia*

Received 23 December 2004; received in revised form 2 February 2005; accepted 19 February 2005

Available online 24 March 2005

## Abstract

The cure of unsaturated polyester was studied by using an experiment and a mathematical model of the process. The temperature–time profiles were recorded in the centre of the resin and also at the outside wall of the cylindrical mould, and in the bulk of the heated air thermostat.

A numerical model was constructed by taking into account the heat transferred by convection from the air to the mould surface and the heat transferred by conduction through the resin, as well as the heat generated by cure reaction. Introduction of the carbon base filler reduced the amount of heat generated in the composite. As a result, it lowered the temperature of the resin. The convection heat transfer coefficient was determined from independent experiments with glycerol inside the mould.

Recording the temperature–time and conversion–time profiles developed within the sample, more extensive knowledge of the process can be obtained. The effects of the convection heat transfer to the mould, and the conduction heat transfer through the mould as well as the internal heat generated by the cure reaction is clearly shown, despite the complexity of the process.

© 2005 Elsevier B.V. All rights reserved.

*Keywords:* Curing; Polyester resin; Heat transfer coefficient; Mould; Mathematical model

## 1. Introduction

In many areas of chemical engineering applications, we have to deal with thermosetting polymer structures. One of the major industrial processing techniques for producing such structures is the curing process [1]. The curing behaviour of unsaturated polyester resins is characterized by a complex mechanism involving copolymerization of the polyester and styrene molecules induced by the decomposition of an initiator. The interaction of chemical kinetics with certain physical processes that take place during curing, such as the phenomena of gelation and vitrification and the possibility of forming different morphological or chemical structures increases the complexity of the curing study [2]. Polyester resin-based composites may be used in many areas, such as medicine (bone cement—filling the gap between bone end metal prosthesis), architecture (artificial marble) and small ship building [3].

The process of thermoset curing inside the mould consists of two main stages: the external heating of the polyester resin (with or without filler) and the cure reaction in the mould. Since the thermosetting polymerization is highly exothermic and the resin has a low thermal conductivity and a moderate heat capacity, the temperature may rise up to 100 °C above the mould wall temperature [4]. Such temperature differences produce thermal gradients through the resin, which are more pronounced in the wider samples. On this account, the final product can exhibit mechanical and thermal properties below its specifications. In addition, thickening agents, inert and reinforcing fillers, initiators, inhibitors, and other additives can also be added to the compound in order to modify the performance of the product [5].

Moreover, the increase in production following the reduction in time of the cure cycle necessitates the use of a higher mould temperature. The rate of heat evolved from the cure reaction varies with temperature according to Arrhenius equation. A higher temperature in the mould is responsible for higher temperature gradients and a higher increase in temperature, which in turn increases the rate of cure reaction [6].

\* Corresponding author. Tel.: +385 1 4597146; fax: +385 1 4597133.  
E-mail address: [vkosar@marie.fkit.hr](mailto:vkosar@marie.fkit.hr) (V. Kosar).

**Nomenclature***Symbols*

$A_r$	Arrhenius number ( $s^{-1}$ )
$c_p$	Specific heat capacity ( $J\ kg^{-1}\ K^{-1}$ )
$E_a$	Activation energy ( $kJ\ mol^{-1}$ )
$dH/dt$	Heat flow ( $J\ s^{-1}\ g^{-1}$ )
$\Delta H_r$	Heat of reaction ( $kJ\ kg^{-1}$ )
$k$	Rate constant ( $s^{-1}$ )
$h$	Convection heat transfer coefficient ( $J\ s^{-1}\ m^{-2}\ K^{-1}$ )
$R$	Mould diameter (0.01 m)
$N$	Number of experimental data
$r$	Radial position (m)
$R_g$	Gas constant ( $8.314\ J\ mol^{-1}\ K^{-1}$ )
$r_A$	Rate of reaction ( $s^{-1}$ )
$t$	Time (s)
$T$	Temperature (K)
$T_0$	Initial temperature (298 K)
$T_m$	Mould wall temperature (K)
$T_{air}$	Air temperature (K)
$T_{gly}$	Glycerol temperature (K)
$x$	Dimensionless radial position (-)
$X_A$	Fractional conversion (-)
$y_{i\ exp.}$	Experimental data $i$ (-)
$y_{i\ teor.}$	Evaluated data $i$ (-)
$w$	Mass fraction (-)
$Nu$	Nusselt number ( $Nu = \frac{hd}{\lambda}$ , -)
$Re$	Reynolds number ( $Re = \frac{\rho ud}{\mu}$ , -)
$Pr$	Prandtl number ( $Pr = \frac{c_p \mu}{h}$ , -)

*Greek Symbols*

$\theta_m$	Dimensionless mould wall temperature (-)
$\mu$	Dynamic viscosity ( $m^2\ s^{-1}$ )
$\rho$	Density ( $kg\ m^{-3}$ )
$\lambda$	Heat conductivity ( $J\ m^{-1}\ s^{-1}\ K^{-1}$ )
$\alpha$	Thermal diffusivity ( $m^2\ s^{-1}$ )

The main structure of the mathematical model is formed by the energy balance, which takes into account several factors: the heat transfer through the air by convection, heat accumulation in the composite, the heat generated by the chemical reaction, the heat conduction through the material, and the heat dissipation at the composite skin. The energy balance equation is coupled with a suitable material balance expressing kinetic behaviour of the chemical reaction. The solution of the complete mathematical system gives both the temperature and the conversion as functions of time and position [7].

The main purpose of this study is precisely to determine the effect of a change in the mould temperature externally heated by stirred air on the process, and especially on the

Table 1  
Resin properties

Components	Weight (%)	Mole ratios (mol)
(a) Propylene glycol	3.3	0.4
(b) Ethylene glycol	7.0	0.6
(c) Diethylene glycol	14.4	1.1
(d) Phthalic anhydride	24.8	1.3
(e) Fumaric acid	14.3	1.0
(f) Styrene	36.3	2.8
(g) Hydroquinone	0.012	–
(h) Fragments	cca. 1	–

profiles of temperature and conversion developed within the sample. Also, the effect of the convection heat transfer coefficient on the process is very important, because it characterises the rate of the heat transferred by convection to the external surface of the mould [8]. This information is necessary not only to enhance understanding of the process but also to determine the best operational condition.

**2. Experimental***2.1. Materials**2.1.1. Thermoset*

General-purpose polyester resin was supplied by Chromos d.d., Zagreb, Croatia. The base polyester resin was prepared using phthalic anhydride, diethylene glycol, fumaric acid and styrene in different molar ratios (see Table 1).

*2.1.2. Filler*

Carbonate-based OmyaCarb 5-GU, supplied by Omya GmbH, Austria.

*2.1.3. Initiator*

A 50% solution of methyl ethyl ketone peroxide (MEKP) in dimethyl phthalate, supplied by Chromos d.d., Zagreb, Croatia.

*2.1.4. Glycerol*

P.a., supplied by Kemika d.d., Zagreb, Croatia.

*2.2. Moulding and heating system*

A cylindrical copper mould with the resin sample was placed in a thermostat heated by the air kept at a constant temperature. A stirrer was placed inside the heated chamber (thermostat) to ensure a continuous air flow across the mould (Fig. 1). Heat transfer was mainly by convection. The temperature was recorded at various places:

- (1) In the centre of the resin sample (Fig. 1, thermocouple (1)).
- (2) In the exterior air (Fig. 1, thermocouple (3)).
- (3) On the external surface of the mould (Fig. 1, thermocouple (2)).

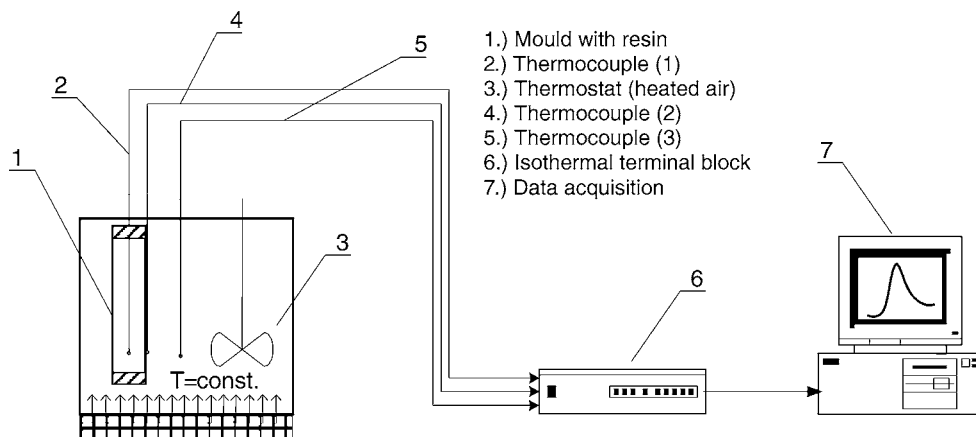

Fig. 1. Schematic representation of the measurement system.

Throughout all experiments, a cylindrical copper mould with 10 mm diameter and 1 mm wall thickness was used (Fig. 2). The mould was placed in the thermostat and heated by stirred hot air. Because we used a long cylinder, heat transfer was assumed to occur only radially, and the circular cross-section of the sample was considered separately. The air temperature was set within the 100–120 °C range.

These temperature measurements are necessary for testing the validity of the model. The centre of the resin along the longitudinal axis was chosen for measuring the temperature for two reasons:

- (1) Because of symmetry, the gradient of temperature is equal to zero, so a better accuracy is obtained at this place. Thus, a slight change in the position of the thermocouple does not significantly alter the temperature measurement.
- (2) The lowest temperature is obtained at the centre of the resin during the stage of pre-heating, and the highest

temperature is attained during the stage of cure reaction. The highest amplitude of temperature is observed at this place.

National Instruments supplied the accessories for data acquisition. The NI4351 card has 16 different analogue inputs. Each instrument has a 24-bit ADC and six possible reading rates – 10, 50, 60 readings per second in the single-channel acquisition mode and 2.8, 8.8, and 9.7 total readings per second in the multiple-channel acquisition mode.

### 3. Results and discussion

Characteristics of temperature–time curves for all experiments can be qualitatively displayed with three characteristic areas (Fig. 3):

- (1) Heating period (induction): resin was heated from room temperature ( $T_0$ ) to the temperature of hot air ( $T_{\text{air}}$ ).
- (2) Curing period (reaction): due to the heat generated in the composite, the temperature increased from  $T_{\text{air}}$  to maximal temperature of the reaction ( $T_{\text{max}}$ ), and

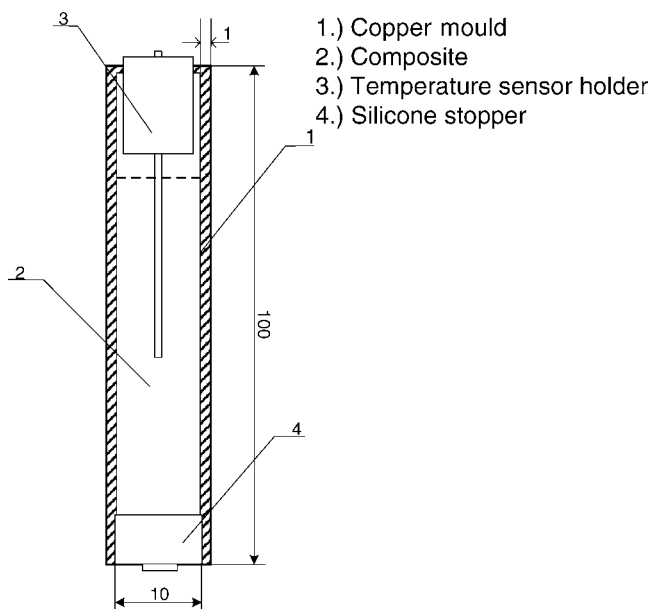

Fig. 2. Schematic representation of the copper mould.

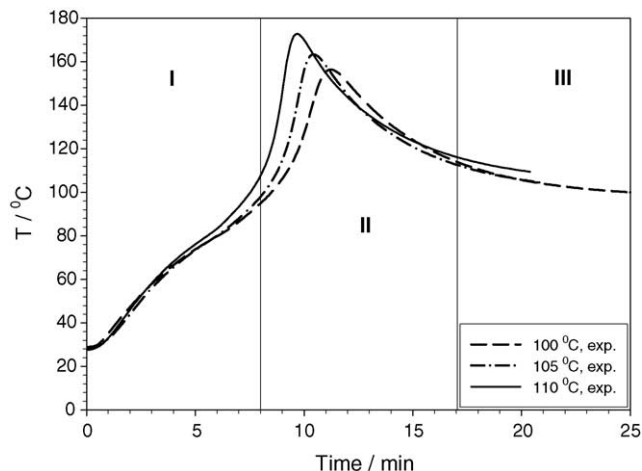

Fig. 3. Temperature vs. time plot with three characteristic areas.

- (3) Cooling period: after reaction, the sample was cooled to the temperature of the heated air ( $T_{\text{air}}$ ).

In order to clarify the problem and to establish the mathematical model of the curing process in the mould, a few assumptions were made:

- (1) Only radial heat transfer by conduction through the cylinder cross-section was considered.
- (2) Heat was transferred by convection through the air-mould interface.
- (3) Due to the large difference in heat conductivity between copper and resin, heat transfer through the mould wall was disregarded (see Table 5).
- (4) The cure reaction is expressed by a single kinetic equation, as obtained from calorimetric determination.
- (5) Within the given temperature interval, thermal parameters  $c_p$ ,  $\lambda$ , and  $\rho$  are predicted as constants.
- (6) Homogenous and pre-mixed reaction system.
- (7) Negligible temperature change during mixing of reaction components.

The equation describing the rate of heat transferred by radial conduction through the circular cross-section is [9]:

$$\rho c_p \frac{\partial T}{\partial t} = \lambda \left[ \frac{\partial^2 T}{\partial r^2} + \frac{1}{r} \frac{\partial T}{\partial r} \right] + r_A \rho \Delta H_r \quad (1)$$

where the contribution due to the exothermic reaction can be seen in the right-hand term and where  $c_p$  and  $\lambda$  are the thermal parameters, and  $\rho$  is the density.

The mass balance for a resin in the cylindrical mould (batch reactor) is given by

$$\frac{\partial X_A}{\partial t} = r_A \quad (2)$$

where  $r_A$  is defined as the rate of cross-linking with kinetic model, Eq. (5).

These two partial differential equations (Eqs. (1) and (2)) with boundary and initial conditions form a mathematical model of the polyester resin curing process in the cylindrical mould. Some experiments were done by heating the mould in the glycerol thermostat. These experiments were performed to show the differences in the time–temperature curves and between the maximum temperatures attained in the resin [8]. By comparing experimental results of curing reaction conducted in air and oil thermostat, important conclusions can be made. Since the product quality depends on the heat transfer, it is important to know and define the regime of temperature changes inside the mould. Tables 2 and 3 represent boundary and initial conditions for a system heated with air or glycerol, as well as a situation with or without the curing reaction.

The main difference between a system heated with air or glycerol is in the boundary condition for the mould wall,  $r = R$ . In the case of glycerol, thermostat temperature of the mould immediately exceeds the temperature of the surrounding fluid (glycerol). On the contrary, a heat transfer through the gas

Table 2  
Boundary and initial condition without curing reaction

Mould in air	Mould in glycerol
Boundary condition	
$\frac{\partial T}{\partial r} = -\frac{h}{\lambda}(T_m - T_{\text{air}})$ , for $r = R$	$T(r, t) = T_m = T_{\text{gly}}$ for $r = R$
$\frac{\partial T}{\partial r} = 0$ , for $r = 0$	$\frac{\partial T}{\partial r} = 0$ , for $r = 0$
Initial condition	
$T(r, 0) = T_0$	$T(r, 0) = T_0$
$T(R, 0) = T_m = T_0$	$T(R, 0) = T_m = T_{\text{gly}}$

(air)-mould interface is by convection, and an appropriate temperature gradient is present.

In a situation without chemical reaction, i.e. when we want to predict the heat transfer coefficient,  $h$ , all terms in the model that relate to the reaction kinetics were rejected (Eq. (2), last boundary and initial condition, Table 3).

### 3.1. Kinetics

Assuming that the exothermic heat generated by curing reaction is proportional to the number of double bonds that have reacted in the system, the maximum conversion is reached when all the bonds that can react have done so [10]. The reaction rate is directly proportional to the rate of heat generation  $dH/dt$ . It is possible to evaluate the reaction rate  $dX_A/dt$  and fractional conversion  $X_A$  reached in time  $t$  using the following expressions [11,12]:

$$\frac{dX_A}{dt} = \frac{1}{\Delta H_r} \left( \frac{dH}{dt} \right)_t \quad (3)$$

$$X_A = \frac{1}{\Delta H_r} \int_0^t \left( \frac{dH}{dt} \right)_t dt \quad (4)$$

The following kinetic equation was used to fit the experimental data [13,14]:

$$r_A = A_r \exp \left( -\frac{E_a}{RT} \right) X_A^n (1 - X_A)^m \quad (5)$$

Kinetic parameters calculated from the DSC experiments are:  $E_a = 41,000$  J/mol,  $A_r = 5,000$  s<sup>-1</sup>,  $n = 0.7$  and  $m = 1.3$ .

Table 3  
Boundary and initial condition with curing reaction

Mould in air	Mould in glycerol
Boundary condition	
$\frac{\partial T}{\partial r} = -\frac{h}{\lambda}(T_m - T_{\text{air}})$ , for $r = R$	$T(r, t) = T_m = T_{\text{gly}}$ , for $r = R$
$\frac{\partial T}{\partial r} = 0$ , for $r = 0$	$\frac{\partial T}{\partial r} = 0$ , for $r = 0$
$\frac{\partial X_A}{\partial r} = 0$ , for $r = 0$	$\frac{\partial X_A}{\partial r} = 0$ , for $r = 0$
Initial condition	
$T(r, 0) = T_0$	$T(r, 0) = T_0$
$T(R, 0) = T_m = T_0$	$T(R, 0) = T_m = T_{\text{gly}}$
$X(r, 0) = 0$	$X_A(r, 0) = 0$

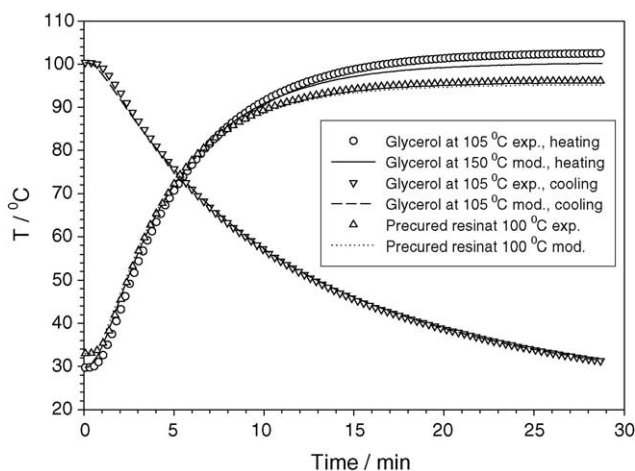

Fig. 4. Curves for estimating  $h$  in the air thermostat.

Detailed kinetic analysis of this system (polyester resin with carbon filler) can be found elsewhere [15].

### 3.2. Estimation of the heat transfer coefficient, $h$

The heat transfer coefficient  $h$  was obtained either by calculation with the dimensionless numbers ([16], Eq. (6)), or by estimating it as a parameter in the curing model without reaction and fitting it with experimental results. The experiments were performed on the same mould containing either glycerol or precured resin. The mould with glycerol in it was previously heated from room temperature in heated air under conditions identical to the cure, or it was allowed to cool down to room temperature in the air thermostat. All experiments were conducted at the same hydrodynamic conditions (stirrer position, air flow). The temperature at the centre of the mould with the glycerol or precured resin was recorded during these processes, and the value of  $h$  was obtained by fitting the experimental temperature–time curves with the calculated ones, Fig. 4.

$$Nu = C Re^n Pr^{1/3} \quad (6)$$

$C$  and  $n$  are constants dependent on the flow regime. In this case, laminar flow was observed ( $Re \cong 2000$ ).

Values of  $h$  shown in Table 4 demonstrate that the convection heat transfer between the air and the copper mould is rather small. In the further calculation, the constant value of  $h = 55 \text{ W/m}^2 \text{ K}$  will be used.

Table 4

Calculated values of the convection heat coefficient,  $h$  ( $\text{J s}^{-1} \text{ m}^{-2} \text{ K}^{-1}$ )

Experiment	
With glycerol	55–60
With precured resin	50–60
From literature (Eq. (6))	60–90

Table 5

Thermal parameters quantities selected from the literature

Material	$\rho$ ( $\text{kg m}^{-3}$ )	$c_p$ ( $\text{J (kg K)}^{-1}$ )	$\lambda$ ( $\text{W (m K)}^{-1}$ )
Resin	1100	1830	0.17
Copper (mould)	8900	390	393
Filler ( $\text{CaCO}_3$ )	4658	550	0.93
Air	1	1014	0.034
Glycerol	1206	2800	0.30

### 3.3. Cure modelling

The suggested mathematical model, Eqs. (1) and (2), was verified by temperature measurements during the cure reaction in the centre of the cylindrically shaped mould at various heated air temperatures.

By introducing dimensionless variables, we get:

- (1) Dimensionless temperature:  $\theta = \frac{T}{T_0}$
- (2) Dimensionless time:  $\tau = \frac{\alpha}{(R/2)^2} t = \frac{\lambda}{\rho c_p (R/2)^2} t$
- (3) Dimensionless length:  $x = \frac{r}{R/2}$ , and
- (4)  $A = \frac{A_r (R/2)^2}{\alpha}$ ;  $B = \frac{E_a}{R_g T}$ ;  $C = \frac{\Delta H_r}{c_p T_0}$

Thermal parameters were taken from the literature [1,5]. They were assumed to be constant throughout the entire temperature range, Table 5.

The number of variables in the solution of heat-conduction problems may be reduced as follows:

Heat balance from Eq. (1):

$$\frac{\partial \theta}{\partial \tau} = \left[ \frac{\partial^2 \theta}{\partial x^2} + \frac{1}{x} \frac{\partial \theta}{\partial x} \right] + C \frac{\partial X_A}{\partial \tau} \quad (7)$$

Material balance, from Eqs. (2) and (5):

$$\frac{\partial X_A}{\partial \tau} = A \exp\left(-\frac{B}{\theta}\right) X_A^n (1 - X_A)^m \quad (8)$$

Eqs. (7) and (8) were solved simultaneously, subjected to the boundary and initial conditions previously defined (also in dimensionless form), by numerical techniques. Since the two partial differential equations were coupled, an iterative procedure was applied. The basic numerical scheme involved utilization of the method of lines for the solution of parabolic partial differential equations (PDE) [17].

The Nelder–Mead (modified Simplex) method was used for model parameters ( $\Delta H_r$  and  $A_r$ ) estimation together with the normalised least squares as error criteria [18], Eq. (9).

$$S.D. = \frac{1}{N} \sqrt{\sum_{i=1}^N (\bar{y}_{i_{\text{exp.}}} - \bar{y}_{i_{\text{teor.}}})^2} \quad (9)$$

Estimated parameters are presented in Table 6. Introduction of inert filler in the composite mixture decreased the reaction heat, but model parameters remained constant, independent of the filler content or of the operation (mould wall) temperature.

Table 6  
Estimated model parameters for system with or without the filler

Air temperature (°C)	$\Delta H_r$ (J g <sup>-1</sup> )	$A_r$ (s <sup>-1</sup> )	S.D.	$w$ (filler), (%)
90	-139.87	4430.67	0.1234	0
95	-144.91	5400.07	0.0895	
100	-165.18	5143.03	0.1421	
105	-172.01	5433.71	0.1145	
110	-177.41	4618.86	0.2155	
90	-90.18	4537.10	0.0895	20
95	-105.55	4367.33	0.0472	
100	-115.86	4194.38	0.1518	
105	-123.88	4205.52	0.1955	
110	-139.42	4904.67	0.0987	
90	-79.34	4567.99	0.0944	40
95	-86.11	3779.14	0.1160	
100	-99.60	4762.05	0.0551	
105	-109.26	4056.68	0.2020	
110	-119.42	3510.70	0.4111	

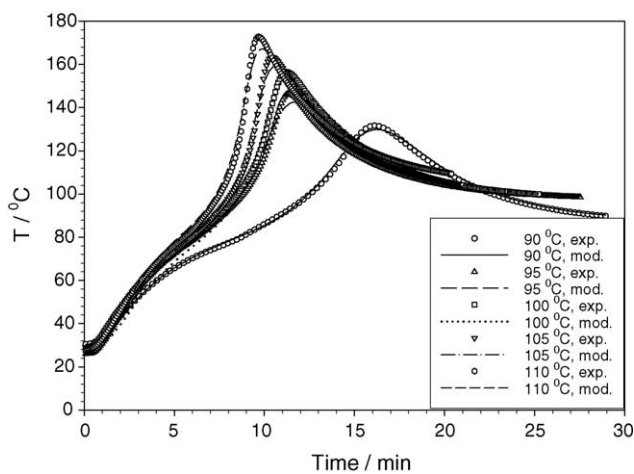

Fig. 5. Comparison between simulation and experimental data for curing of resin without filler.

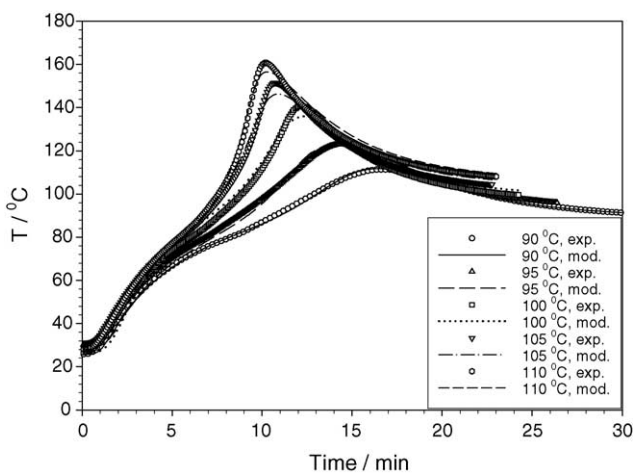

Fig. 6. Comparison between simulation and experimental data for curing of resin with 20% of filler.

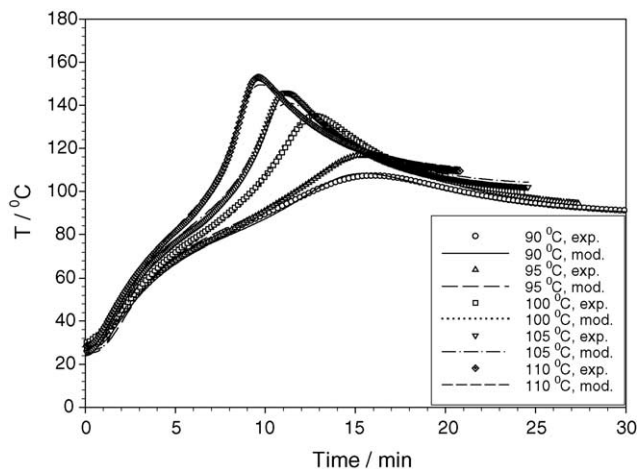

Fig. 7. Comparison between simulation and experimental data for curing of resin with 40% of filler.

Good agreements between experimental and estimated data were observed for temperature versus time plots in the centre of the composite (Fig. 5). The presence of the filler in all cases (Figs. 6 and 7) lowered the maximum temperature reached during the cure cycle. Increasing the filler content has reduced the total quantity of the resin, thereby decreasing the amount of heat generated per gram of the reaction mixture [5], Table 6.

High enthalpy of the cure associated with the rather low thermal conductivity can give rise to an excessively high temperature, which may cause discoloration and degradation of the material, and also lead to substantial temperature gradients. Thus, the material is heterogeneous during the curing process, and these temperature gradients in the resin may have significant effects on the properties of the final material [8].

Generally, the cure reaction starts on the surface of the resin where the highest temperatures persist. However, because of the internal heat generated by the cure reaction as-

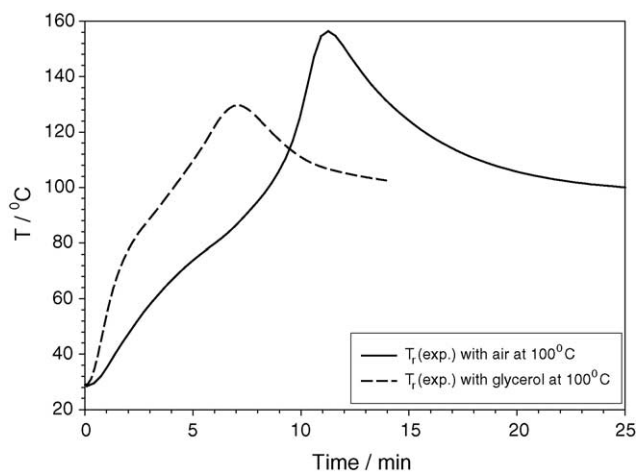

Fig. 8. Comparison between measured temperature in the mould centre for system heat with the air or glycerol.

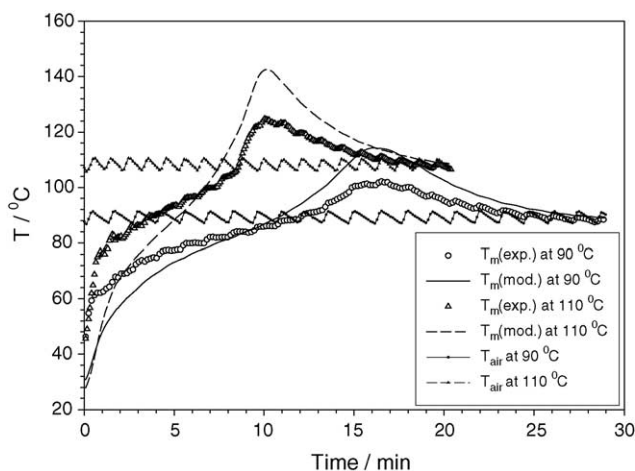

Fig. 9. Comparison between measured temperature near the mould wall and calculated temperature of the mould wall.

sociated with the low thermal conductivity, gradients of temperature develop within the resin with the highest temperature in the centre of the resin. The temperature–time history at the centre passes through the maximum, and normally decreases down to the mould wall temperature (Figs. 5, 6 and 7).

According to Fig. 8, heat transfer by convection from the air to the mould surface is slower than the heating of the mould at the same glycerol temperature as the air. Slow heat transfer governs higher temperature gradients in the composites. As a result, a higher temperature is obtained in the centre of the resin (almost 30 °C higher temperature when heated with the air).

Besides the temperature measurement in the centre of the resin, temperature is measured in the bulk of a hot air,  $T_{\text{air}}$ , and near the mould wall,  $T_{\text{m}}(\text{exp.})$ . It was shown that the  $T_{\text{m}}(\text{exp.})$  describes temperature on the air–mould interface better than the temperature in bulk of a hot air,  $T_{\text{air}}$ . From the Fig. 9 which shows temperature measured near the mould wall,  $T_{\text{m}}(\text{exp.})$  and the temperature of the mould wall calculated from the model,  $T_{\text{m}}(\text{mod.})$ , some remarks may be drawn out:

- (1) During the heating period, where,  $T_{\text{m}}(\text{mod.}) < T_{\text{m}}(\text{exp.}) < T_{\text{air}}$ , heat is transferred by convection from the air to the air–mould interface.
- (2) When reaction starts (near the inner surface of the mould wall) reaction heat is transferred by conduction both to the resin centre and also to the mould wall. At that moment,  $T_{\text{m}}(\text{mod.}) > T_{\text{m}}(\text{exp.})$ , heat is transferred by convection from the mould wall to the air through the boundary layer.  $T_{\text{m}}(\text{exp.})$  becomes greater than  $T_{\text{air}}$ .
- (3) When temperature in the centre of the resin reaches maximum,  $T_{\text{max}}$ , temperatures  $T_{\text{m}}(\text{exp.})$  and  $T_{\text{m}}(\text{mod.})$  also attain highest values.
- (4) At the end, after cooling, all temperatures are nearly identical ( $T_{\text{resin}}(\text{centre})$ ,  $T_{\text{m}}(\text{exp.})$  and  $T_{\text{m}}(\text{mod.})$ ). The process is finished when it is in equilibrium with  $T_{\text{air}}$ .

#### 4. Conclusions

The main characteristic of the mould heated by the air is convection heat transfer from the air to the mould surface. This fact is responsible for the low rate of heat transfer between the resin and the surrounding atmosphere, which is evident both during the heating period of the mould when it is put in contact with the heated air or during the period of reaction when the resin is hotter than the air in surrounding atmosphere.

Because of the simultaneous occurrence of two processes (heating and cure reaction), this process is very complex. The use of a numerical model that takes into account all the known facts is thus of great importance for a number of reasons:

- (1) It can give a fuller insight into the process, with profiles of temperature and conversion developed through the sample that contribute to the heterogeneity of the sample and to poor properties of the final material.
- (2) It is necessary for determining the best operational conditions for a given size of the mould, when it is desirable to reduce the time of cure, and to improve the productivity.
- (3) It is the most powerful technique for evaluating the new operational conditions, which should be used for large samples. Increasing dimensions of samples is always difficult, but it is even more difficult and more sensitive in the case of cure reaction with high enthalpy. By simulating the process, the model can predict difficulties that may arise with a change in dimensions of the sample.

According to the results presented in this paper, several facts were important for the successful cure process control:

- (1) Rate of the cure reaction governed by the initiator concentration,
- (2) Execution (type) of heating, with the air or with glycerol (oil), which governs the mechanism of heat transfer from the heating media to the mould,
- (3) The amount of filler, which is responsible for the lower maximum temperature of composite in the mould, and
- (4) Operating temperature (air temperature, mould wall) should be sufficient for an initiator decomposition but should not allow high-temperature gradients in the composite.

#### References

- [1] L.J. Lee, *Polym. Eng. Sci.* 21 (1981) 483–492.
- [2] P.J. Flory, *Principles of Polymer Chemistry*, Cornell University Press, New York, 1953.
- [3] A. Nzihou, P. Sharrock, A. Ricard, *Chem. Eng. J.* 72 (1999) 53–61.
- [4] V. Plesu, R. Granger, J. Bouzon, J.M. Vergnaud, *Thermochim. Acta* 241 (1994) 67–85.
- [5] S.H. McGee, *Polym. Eng. Sci.* 22 (1982) 484–491.
- [6] W.D. Cook, G.P. Simon, P.J. Burchill, M. Lau, T.J. Fitch, *J. Appl. Polym. Sci.* 64 (1997) 769–781.
- [7] A. Sahli, R. Granger, J.M. Vergnaud, *Thermochim. Acta* 285 (1996) 277–288.

- [8] J.M. Vergnaud, J. Bouzon, *Cure of Thermosetting Resins: Modelling and Experiments*, Springer-Verlag, London, 1992.
- [9] V. Plesu, J.M. Vergnaud, *Thermochim. Acta* 228 (1993) 83–93.
- [10] J.M. Kenny, A. Maffezzoli, L. Nicolais, *Comp. Sci. Tech.* 38 (1990) 339–358.
- [11] C.H. Han, K.W. Lem, *J. Appl. Polym. Sci.* 28 (1983) 3155–3183.
- [12] S.Y. Pusatcioglu, J.C. Hassler, A.L. Fricke, *J. Appl. Polym. Sci.* 24 (1979) 937–946.
- [13] M.R. Kamal, *Polym. Eng. Sci.* 14 (1974) 231–239.
- [14] A. Yousefi, P.G. Lafleur, R. Gauvin, *Polym. Comp.* 18 (1997) 157–168.
- [15] V. Kosar, Z. Gomzi, *Chem. Biochem. Eng. Q.* 15 (2001) 101–108.
- [16] J.P. Holman, *Heat Transfer*, McGraw-Hill, Tokyo, 1981.
- [17] W.E. Schiesser, *The Numerical Method of Lines: Integration of Partial Differential Equations*, Academic Press, San Diego, 1991.
- [18] D.M. Himmelblau, *Process Analysis by Statistical Methods*, John Wiley & Sons, New York, 1970.