

The thermal analysis of films in the 21st century: Relevance to cell culture, biochips and roll-to-roll circuits

Michael Jaffe^{a,*}, George Collins^a, Joseph Menczel^b

^a Department of Biomedical Engineering, New Jersey Institute of Technology, Medical Device Concept Laboratory,

111 Lock Street, Newark, NJ 07103, USA

^b Alcon Laboratories, Fort Worth, TX, USA

Available online 2 March 2006

Abstract

Films may be considered as wide fibers, or as unique material geometry possessing two dimensional symmetry ($X, Y \gg Z$). Potentially different uniformity issues along the machine (long) and transverse directions of the film, characterization of Z-axis performance—especially as films become “thin” and the characterization/identification of surface modification, introduce the need for careful sampling strategies if the resulting thermal analysis data is to be reflective of either process history or end-use performance or both. Two dimensional imaging by a combination of techniques—i.e., DSC–WAXS–FTIR–AFM exploit the convenience of the sample geometry, while aiding in the definition of structural complexity. Molecular spectroscopy techniques (DMA, TSC) provide a sensitive and instructive tool for examining novel surface or interface chemistry. Characterization under biorelevant conditions (37 °C, aqueous, standard saline, presence of adhesive and other proteins, presence of cells) is critical for the generation of meaningful data on films to be utilized biologically (cell culture, tissue engineering substrates, biochips). Of special interest are strategies for accelerated aging that allow prediction of biological or biorelevant performance.

© 2006 Elsevier B.V. All rights reserved.

1. Introduction

The thermal analysis of films, like the thermal analysis of fibers, is the thermal analysis of oriented polymers. Films, defined as two dimensional structures where the in-plane dimensions – length and width – are much greater than the film thickness. In most commercial film production films are produced continuously, the length then becomes the essentially infinite machine direction (MD), the width the finite web dimension or the transverse dimension (TD). Cast films and pressed films represent batch processes – most common commercial process is spin casting where a polymer solution is sprayed onto a revolving plate leading to radial symmetry in the plane of the film – in the case of films cast on a liquid, glass or other smooth surface in-plane symmetry is very much a function of process details. All of the issues previously discussed with respect to the thermal analysis of fibers are true for films [1,2] and these issues will not change with the passage of time. The key to successful utilization of thermal analysis in film characterization lies in the understanding of the process details, how these

process details affect point-to-point film morphology, and how these morphological features translate into film performance. Because the two dimensional nature of films leads to complex symmetries in structure formation, sampling strategy becomes a critical issue in film thermal analysis. Most desirable is to have exact knowledge of where a given sample originates with regard to the film production method. When this is not possible, useful information may be still be obtained but insight into the important issues of point to point performance differences is much more difficult. Two of the more common methods of film production—melt casting followed by drawing and film blowing are illustrated in Fig. 1. In the case of film casting and drawing, a low orientation precursor film is extruded from the melt, then drawn in the machine and transverse directions to produce a biaxially oriented final product. Structure and properties are dependent not only on the extent and temperatures of the draw steps but also on the sequence in which they are performed and the orientation distribution is different in the MD and TD directions. Process history can be further complicated by the introduction of annealing steps, relaxation steps, coating (regard a coating as a thin film of a different chemistry). If the film is drawn only in the machine direction the analogy to fiber symmetry becomes stronger—narrow films (tapes) are often utilized in laboratories for ease in mounting in various

* Corresponding author.

E-mail address: jaffe@adm.njit.edu (M. Jaffe).

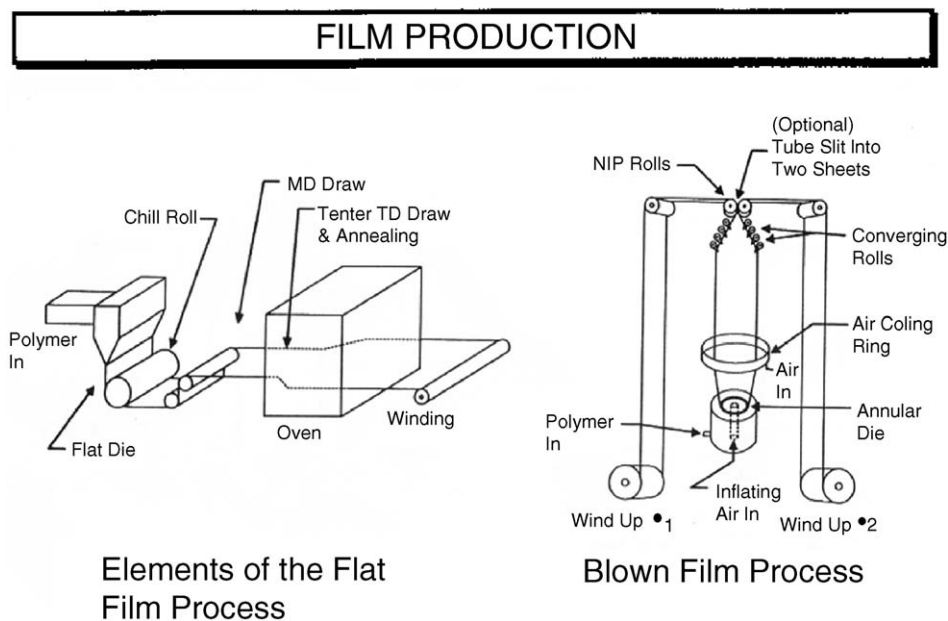

Fig. 1. The commercially practiced film production processes.

thermal analysis instruments and, even more conveniently for use as samples for spectroscopy or diffraction. In contrast, film blowing produces materials where orientational symmetry, in both the MD and TD directions, while different are inherently uniform.

Changes in film thermal analysis in the 21st century, as in the case already discussed for fibers, lies in the applications rather than in the techniques. Nano, bio, thin, multilayer and smart are the concepts that are driving new product formulations. Films also play an increasingly important role in preserving the properties into sophisticated structures by serving as protective packaging. The review of thin film thermal analysis by Gallagher in 1992 [3] is a good starting point for understanding the applications of thermal analysis to thin films. Interesting applications of specific thermal analysis techniques may be found in the work of Allen and Olson [4], and Price [5]. This paper will focus on understanding the influence of polymer assembly in behavior under biorelevant conditions, the use of combined techniques and spectroscopy to further this understanding. Because of its increasing commercial importance, a classical example of the thermal analysis of multilayer films will also be discussed.

2. Experimental

2.1. Sample preparation

Films of selected poly(desaminotyrosylesteramide) were prepared from powders by compression molding at 140 °C using a Carver press. Films were examined microscopically under crossed polar to assure uniform and low molecular orientation. After compression molding, the samples were stored in a desiccator to prevent water absorption.

2.2. Molecular spectroscopy–thermally stimulated current (TSC) analysis

Thermally stimulated current is a phenomenon in which a current is generated due to displacement of charges as a response to an applied electric field. When a material is placed under an electric field, the polar groups in the material align with respect to the electric field. The movement of these polar groups generates a current that is measured. TSC is the technique that is used to detect and analyze these currents. It is thermally stimulated because in this technique the current that is generated as a response to the electric field is analyzed as a function of temperature. This technique is sensitive to any molecular motion in the material. These molecular motions can be glass transitions and conformational motions. There are also motions due to enthalpic consideration such as crystal or liquid crystal transitions. It is expected that the movements due to T_g , conformational motions and dipole relaxations generate smooth polarization peaks compared to sharp polarization peaks observed in the type of movements due to enthalpic ordering. TSC can be performed by either thermally stimulated polarization current (TSPC) or by thermally stimulated depolarization current (TSDC). In TSDC an electric field is applied to the material at a specific temperature in which there is enough energy for molecular motion. An electric field is applied so that the polar groups are aligned. After this, the material is brought to a lower temperature at a specific cooling rate, with the electric field still applied. At the lower temperature the dipoles are no longer mobile and the orientation due to the polarization remains. Once the polar groups are frozen in the alignment, the electric field is turned off and the material is heated at a specific heating rate. As the material is heated, the oriented polar groups again become mobile but this time without the electric field. This leads to the polar groups to

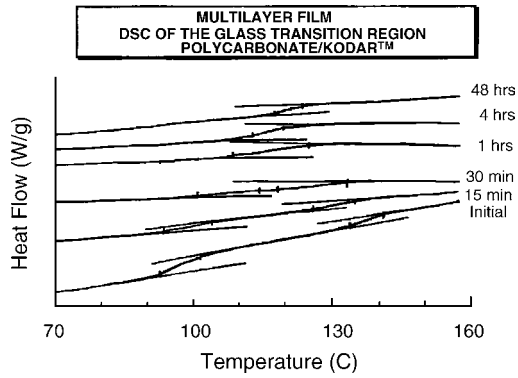

Fig. 2. Analysis of the glass transition of a polycarbonate-polyester multilayer film after thermal exposure.

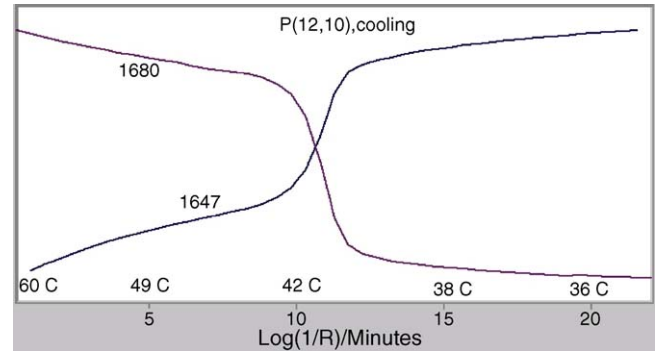

Fig. 4. Change in the intensity of infrared absorption upon cooling a film of Poly(DTDD D) [8].

reorganize in the more stable unaligned configuration. As they reorganize the motion of the polar groups generates a current. This is the thermally stimulated depolarization current.

TSPC is a method in which the material is brought to a lower temperature without the electric field. The material is then heated at a specific heating rate with the electric field on. The current that is generated as the polar groups align due to the electric field is called TSPC. In both cases – TSC and TSPC – the current measured is due to the displacement of charged groups within the material. The current thus generated is related to the number of charged groups present in the material. The motion of the dipoles as they move from the oriented to the unoriented disposition generated an experimentally detectable electric current. This process is called depolarization and the rate of depolarization, the loss of polarization per unit time, is the depolarization current [6].

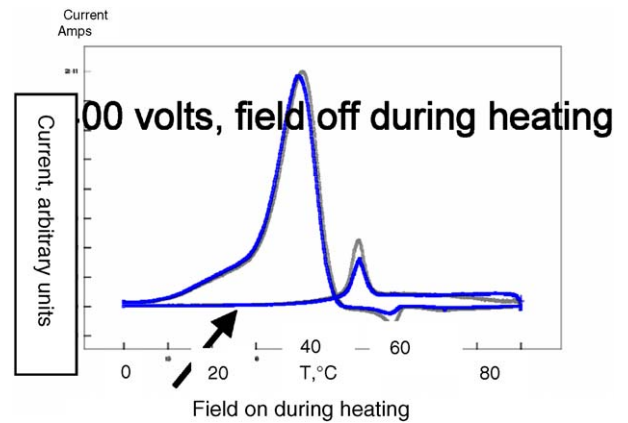

Fig. 5. Thermally stimulated current spectra of Poly(DTDD D) showing the effect of having the polarizing voltage on or off.

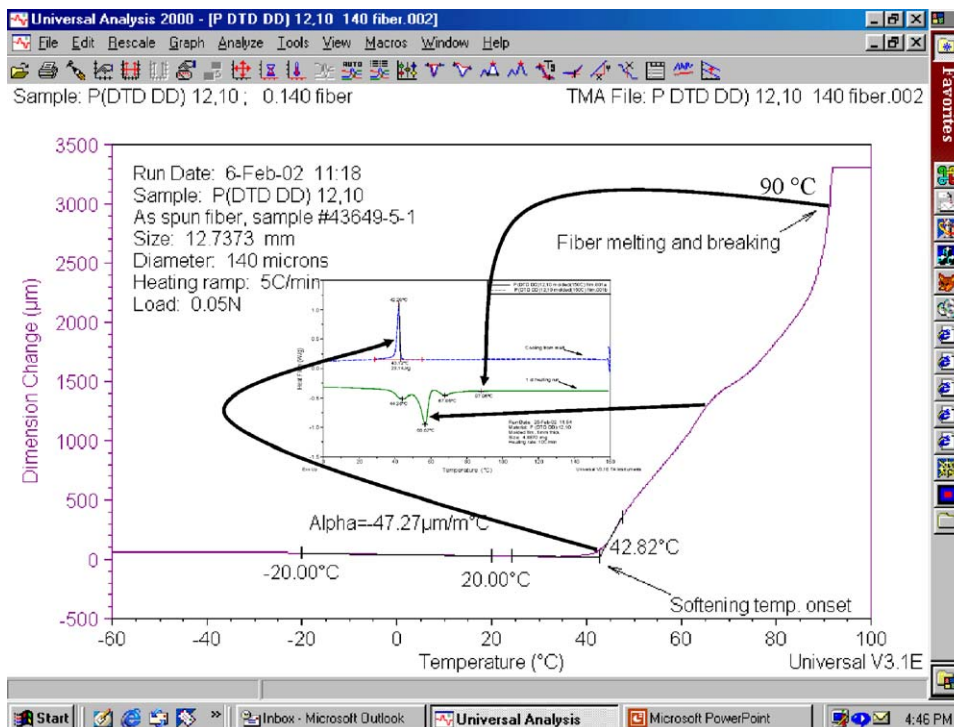

Fig. 3. Correlation of DSC and TMA results for Poly(DTDD D).

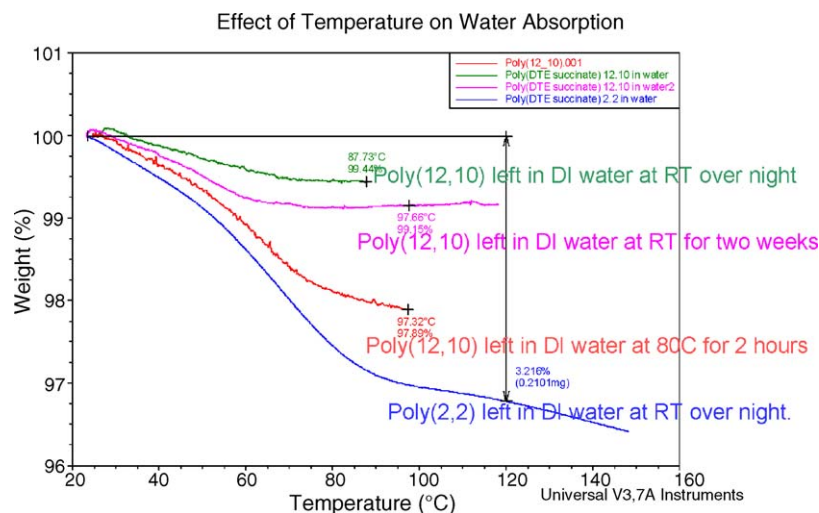

Fig. 6. The water absorption of Poly(DTDD D) as a function of uptake temperature as measured by TGA.

3. Results and discussion

3.1. The glass transition of multilayer films—polycarbonate/polyester copolymer

Pollack et al. [7] examined the glass transition of polycarbonate-polyester copolymer multilayer films as a function of the film thermal history. Multilayer film production techniques were used to produce micron scale layers, with the number of layers in the hundreds. Typical results are shown in Fig. 2. For unannealed films, the glass transition of each component is clearly visible and is at the temperature expected for the pure starting polymers. As the samples are annealed at 200 °C as a function of time, transesterification proceeds and the T_g 's approach one another, merging into a single T_g after 48 h of thermal exposure. These results illustrate the importance the total process history of the sample to fully understand the observed results.

3.2. Defining the molecular assembly of poly(desaminotyrosyl dodecyl deconate)

The existence of long range order in the bioerodable polymeric biomaterial poly(desaminotyrosyl dodecyl deconate) (Poly(DTDD D)) was discussed earlier [1] in the context of oriented fiber behavior. Fig. 3 shows changes in creep modulus of a low orientation fiber, superimposed on the same fiber DSC trace. The data show that all changes observed in the creep modulus occur at transition temperatures noted in the DSC result. The fiber does not start to creep appreciably until the phase change temperature of 42 °C is reached (while the coefficient of linear thermal expansion may change at the reported T_g of about 12 °C, this is not evident from the data presented) and all subsequent modulus decreases can be associated with higher temperature endothermic events. Analysis of the infrared absorption from films of this polymer indicate that there is an absorption (1644 wave numbers) associated with ordered hydrogen bonding in the region of the amide linkage carbonyl while the absorption noted

at 1652 wave numbers is associated with disordered H bonds [8]. Fig. 4 shows the change in infrared absorption in the amide region as a film of Poly(DTDD D) as it is cooled through 42 °C, showing conclusively that long range order in this polymer is associated with backbone H bonding. The question was then raised as to the effect of the nature of the interchain H bonding on the ability of these polymers to absorb water. The body temperature shrinkage of the poly(desaminotyrosylethyl adipate) was conclusively associated with plasticization by water [9]. Fig. 5 shows the TSC spectrum of Poly(DTDD D) indicating a broad relaxation process followed by a second process likely due to a first order transition. This was shown to be the case running the TSC spectrum while keeping the poling voltage on, thus restraining the relaxation process while allowing the enthalpically driven higher temperature dipole relaxation still occurs. The proof that strong hydrogen bonding prevents water absorption in this polymer is illustrated in the TGA data shown in Fig. 6, detailing the water uptake of Poly(DTDD D) films as a function of temperature. Note the jump to greater than 2% water uptake at temperatures above the first order transition. This shows unequivocally that the water uptake is associated with weak H bonding in the region of the amide linkage. Only by the integration of a series of thermal analytical and supporting techniques could the complexity of the biorelevant behavior of this polymer be clarified [6].

4. Conclusions

The importance and strength of thermal analysis as a tool for the characterization of films has not changed and will not change in the future. Principles described decades ago [1] are still valid, understanding the process history and detailed morphology of films is still the critical factor in understanding the results of fiber thermal analysis although in cases where this is not present, significant information about the chemical and morphological state of the fibers can still be deduced. To deduce the origins of complex behavior, especially when that behavior is critical to in-vivo performance of novel medical devices, the

use and integration of multiple techniques is required. What is changing in the 21st century is the emphasis on nano, bio, high performance and smart and this introduces new problems and new opportunities for the thermal analyst. It is up to the thermal analysis community to learn the origins of the problems presented to them by becoming familiar with the underlying science and technology, thus to insure that the powerful thermal analysis tool continues to grow in utility.

References

- [1] M. Jaffe, J. Menczel, G. Collins, in: *Proceeding of the NATAS Annual Conference on Thermal Analysis and Applications*, vol. 32, 2004, in press.
- [2] E. Turi (Ed.), *Thermal Characterization of Polymeric Materials*, second ed., 1997, pp. 1955–2089.
- [3] P.K. Gallagher, *J. Therm. Anal.* 38 (1–2) (1992) 17–26.
- [4] L.H. Allen, E.A. Olson, in: *Proceedings of the NATAS Annual Conference on Thermal analysis and Applications*, vol. 30, 2002, pp. 64–67.
- [5] D.M. Price, in: *Proceeding of the Conference of the North American Thermal Analysis Society*, vol. 26, 1996, pp. 13–15.
- [6] A. Recber, *Masters Thesis*, 2004, in press.
- [7] G. Pollack, S. Nazarenko, S. Hilton, E. Baer, *J. Appl. Polym. Sci.* 52 (1994) 163.
- [8] M. Jaffe, Z. Ophir, V. Pai, *Thermochim. Acta* 396 (2003) 141–152.
- [9] M. Jaffe, Z. Ophir, G. Collins, A. Recber, S.-u. Yoo, J. Rafalko, *Polymer* 44 (19) (2003) 6033–6943.