

A NEW MULTI-BODY METHOD FOR THE DETERMINATION OF THERMOKINETICS

JACEK HATT, EUGENIUSZ MARGAS and WOJCIECH ZIELENKIEWICZ

Institute of Physical Chemistry Polish Academy of Sciences, 01-224 Warsaw (Poland)

(Received 10 November 1982)

ABSTRACT

In this paper a new multi-body method for the determination of thermokinetics is presented. The theoretical base of the method, practical procedure of application and stability conditions of numerical solution are given. The efficiency of the reconstruction of thermokinetics by the method presented is shown on a microcalorimeter of the Unipan 600 type in which known heat pulses were generated.

INTRODUCTION

From the beginnings of calorimetry the aim of scientists was to determine simultaneously the enthalpy changes of a reaction and its kinetic parameters by means of calorimetric measurements. In 1908 Duclaux [1] determined calorimetrically, as far as we know for the first time, the value of the rate constant of reaction, i.e. the rate constant of saccharosis inversion. During the development of conduction calorimetry, the works of Świętosławski [2] and Calvet and Prat [3] created the base for a wide generalization of methods for determining thermokinetics, e.g. function $W(t)$ determining the course of changes of heat power in time. During the past decade a dynamic development of numerical and analogue methods used in conduction calorimetry [4], which increase the possibilities of precise determination of heat power, $W(t)$, [5] on the basis of calorimetric measurements, has been observed. All these methods are based on the assumption that the calorimeter in which the reaction is examined is a "black box" having the properties of a linear inertial N -order object.

In this paper, we introduce the method of determination of thermokinetics based on the physical parameters of the calorimeter. This method requires evaluation of a dynamic model of the calorimetric system; in order to carry out analysis of the course of heat effects in the system. This method, in contradiction to other methods, does not require multiple calibrations of the calorimeter. The method presented is simple and can be applied successfully

for determination of thermokinetics using "personal computer" or analogue systems.

METHOD

The proposed method is based on the assumptions of the multi-body theory [6]. This theory treats a calorimeter as a system of domains (bodies), which can be characterized by their heat capacities, K_i . It is accepted that, each of these bodies can be characterized by a homogeneous temperature, $T_i(t)$, in its whole volume. Additionally, in each of the distinguished bodies heat power source, $W_i(t)$, can be present. Bodies are separated by media, whose thermal properties are characterized by heat loss coefficients. The heat balance equations for such a body system can be given as a set of ordinary linear differential equations.

$$K_i \frac{dT_i(t)}{dt} + \sum_{\substack{j=1 \\ j \neq i}}^N G_{ij} [T_i(t) - T_j(t)] + G_{i0} [T_i(t) - T_0] = W_i(t) \quad (1)$$

$$i = 1, 2, \dots, N$$

where G_{ij} is the heat loss coefficient between the i th and j th body; G_{i0} is the heat loss coefficient between the i th body and the environment; t is the time. If we assume that the calorimetric system is placed in the thermostat (environment) at a constant temperature, T_0 , which is accepted as the reference temperature, so that $\theta_i(t) = T_i(t) - T_0$. Equation (1) can be given as

$$K_i \frac{d\theta_i(t)}{dt} + G_i \theta_i(t) - \sum_{\substack{j=1 \\ j \neq i}}^N G_{ij} \theta_j(t) = W_i(t) \quad (2)$$

$$i = 1, 2, \dots, N$$

where

$$G_i = \sum_{\substack{j=0 \\ j \neq i}}^N G_{ij} \quad i = 1, 2, \dots, N$$

The particular form of these equations for a calorimetric system depends on the number of distinguished bodies, on the heat interactions between these bodies and on the mutual localization of heat sources and temperature sensors. The determination of a particular form of these equations is equivalent to determination of the model of the given calorimetric system. It is necessary to describe the heat capacities, K_i , of the bodies, and characterize the heat interactions between the bodies by heat loss coefficients, G_{ij} , and also heat interactions between the bodies and the environment by

heat loss coefficients, G_{i0} . The values of coefficients G_{ij} , G_{i0} and heat capacities, K_i , are determined on the basis of knowledge of the physical parameters of the calorimetric system (e.g. thermal conductivity, volume, specific heat).

In the method proposed for the determination of thermokinetics it is assumed that, a domain (domains) is distinguished, whose heat capacity, $K_i(K_i, K_{i-1})$, corresponds to the heat capacity of the substance examined (or substance and calorimetric vessel). Then eqn. (2) takes the form

$$K_i \frac{d\theta_i(t)}{dt} + G_i \theta_i(t) - \sum_{\substack{j=1 \\ j \neq i}}^N G_{ij} \theta_j(t) = W_i(t) \quad i = 1, 2, \dots, p-1, p+1, \dots, N \quad (3a)$$

$$K_p \frac{d\theta_p(t)}{dt} + G_p \theta_p(t) - \sum_{\substack{j=1 \\ j \neq p}}^N G_{pj} \theta_j(t) = W_p(t) \quad (3b)$$

Equation (3b) describes the so-called "changeable" part of the calorimetric system. The remaining part of the calorimetric system described by eqn. (3a) corresponds to an "empty" calorimeter. This part can be called the "non-changeable" part of the calorimetric system. This method of formulation of the problem admits that the calorimetric system can be characterized unequivocally by the particular form of eqn. (3). For such a set of equations, an algorithm procedure and program of calculations for the thermokinetics can be worked out. The change in the object examined is connected with the change in the value of K_p in the deconvolution program. According to the proposed method, the dynamic properties of the examined calorimetric system are characterized by its transmittance, whose form should characterize the system structure, distinguish its time constants, and enable, by direct use of an inverse filter method, determination of the thermokinetics of the process examined. In order to determine the transmittance, the Laplace transformation was applied to the differential eqn. (3) at zero initial conditions so that eqn. (3) can be written in a matrix form

$$A(s) \theta(s) = W(s) \quad (4)$$

The particular elements of matrix $A(s)$ are $a_{jj} = K_j s + G_j$, $a_{ij} = -G_{ij}$, $i \neq j$. $\theta(s)$ is the Laplace transform of the state vector, whose components are the temperatures of the distinguished bodies. $W(s)$ is the Laplace transform of the heat power vector, whose components are the heat powers generated in the distinguished bodies. Knowing the particular form of eqn. (3), it is possible to determine the transmittance, $H_{ji}(s)$, of the calorimetric system.

$$H_{ji}(s) = \frac{(-1)^{j+i} |A_{ji}(s)|}{|A(s)|} \quad (5)$$

where $|A(s)|$ is the determinant of the matrix $A(s)$ and $|A_{ji}(s)|$ is the corresponding minor of this matrix.

The determinant $|A(s)|$ gives, after development in power series with respect to s , a polynomial of N -degree

$$|A(s)| = \sum_{n=0}^N a_n s^n = f(s) \quad (6)$$

The determinant $(-1)^{j+i}|A_{ji}(s)|$ gives, after development in power series with respect to s , a polynomial of m -degree

$$(-1)^{j+i}|A_{ji}(s)| = \sum_{k=0}^m b_k s^k = g_{ji}(s) \quad (7)$$

where $0 \leq m \leq N - 1$. Determination of the transmittance, $H_{ji}(s)$, of the calorimetric system in eqn. (5) equals calculations of coefficients of the

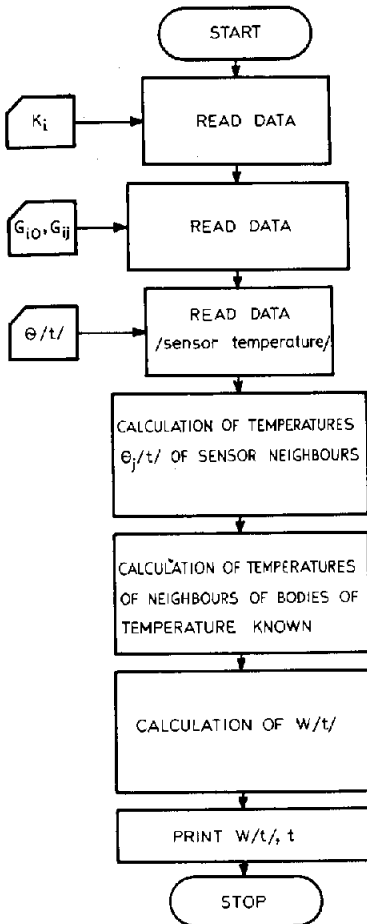

Fig. 1. Flow diagram of the algorithm.

polynomials $f(s)$ and $g_{ji}(s)$. The determined transmittance has the form

$$H_{ji}(s) = \frac{b_0}{a_0} \prod_{k=1}^m (L_k s + 1) : \prod_{n=1}^N (M_n s + 1) \quad (8)$$

where $-1/L_k$ is the root of transmittance (root of the numerator of transmittance) and $-1/M_n$ is the pole of transmittance (root of the denominator of transmittance).

The determination of the transmittance unequivocally determines the dynamic properties of the calorimetric system examined. In this method it is assumed that the determination of its particular form and the knowledge of values a_0 , b_0 , L_k and M_n is sufficient for determination of thermokinetics only when optimization and stability conditions of numerical solution are fulfilled. These conditions demand admission of a value of a sampling period. In this paper a criterion based on the frequency response was used [7]. The value of the optimal sampling period was taken as $h_{\text{opt}} = \pi/\omega_k$, where ω_k is the solution of the equation $|\theta(j\omega)| = 0.01$. Having h_{opt} determined on the basis of this criterion, it has to be checked whether this value is smaller than the smallest time constant of the system. Such a calorimetric model whose time constants fulfil this condition can be used for determination of thermokinetics.

For this purpose two methods can be used: (a) determination of $W(t)$ numerically or by analogue correction on the basis of the transmittance; (b) determination of $W(t)$ on the basis of the particular form of the set of heat balance equations. Using the second possibility, the differential eqn. (3) is approximated by difference equations. The iteration procedure for solving eqn. (3) calculates step by step the temperatures of the neighbouring bodies to the sensor, and then the temperatures of the bodies neighbouring the bodies of which the temperatures are determined in the first step. The procedure leads to the calculation of the temperature of the bodies in which the heat source is located. On the basis of this temperature, the value of $W_i(t)$ is calculated. The algorithm of calculations is given in Fig. 1.

RESULTS AND DISCUSSION

The aim of the experiments was to prove that the method proposed for the determination of thermokinetics can be used practically in an existing calorimetric system. Determination of the thermokinetics required the determination of physical parameters and analysis of the course of heat effects of the calorimetric system examined, calibration measurements for the verification of the model, and measurement of heat effects. For calibration measurements of the calorimetric system studied, a heat effect in the form of a pulse of power 10 W and time 3 s (Dirac pulse) was generated in the calorimeter. A series of measurements of the effects of heat power and time

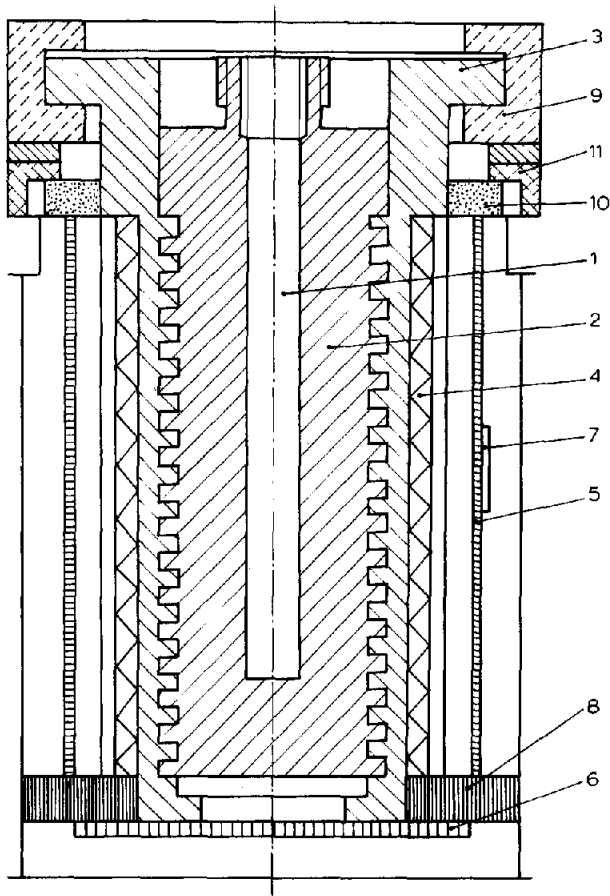

Fig. 2. Construction of the microcalorimeter. 1, Calorimetric heater; 2, calorimetric vessel; 3, shield; 4, 5 and 6, aluminium shields; 7, resistance sensor; 8, 10 and 11, supports; 9, metallic support.

of duration, as shown in Fig. 5, were generated next. These pulses were generated by a calorimetric heater using a current programmer. The calorimetric responses (thermograms) were registered by a digital voltmeter with a precision of three digits.

These measurements were carried out in a microcalorimeter of the Unipan 600 type [8]. It is a differential system consisting of two identical calorimetric vessels placed in a common internal shield. The construction of this type of microcalorimeter enables measurements to be carried out in diathermic conditions (with constant temperature of the shield) and in scanning conditions (with programmed temperature of the shield). A built-in electronic system also provides the possibility of analogue correction of thermograms.

The elements in the construction of the microcalorimeter are shown in Fig. 2. The division into a changeable part (elements 1 and 2) and a

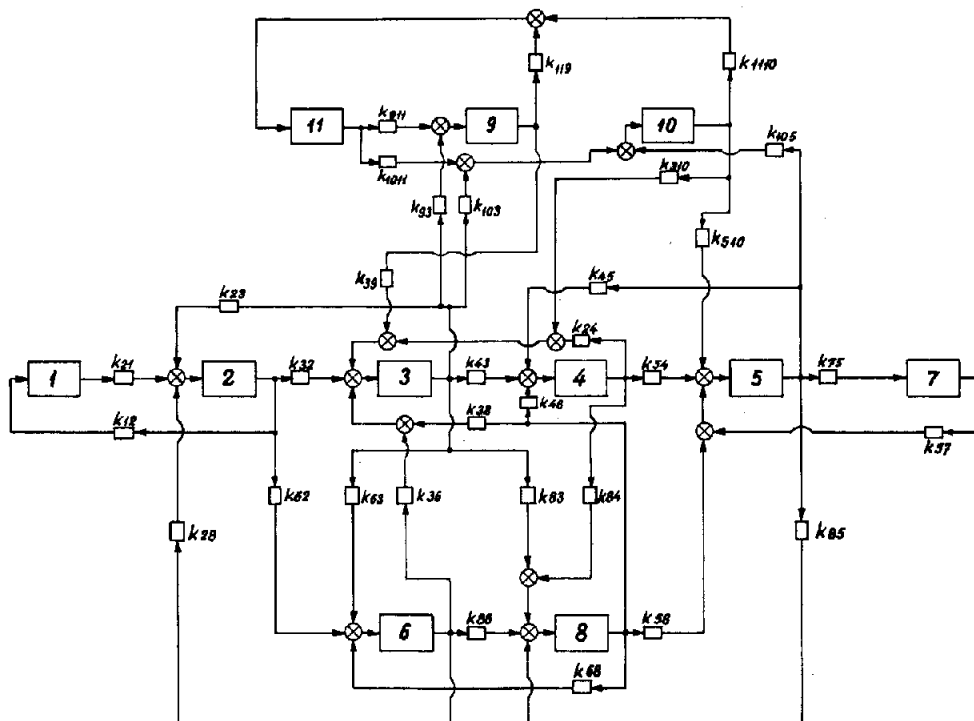

Fig. 3. Block diagram of the calorimetric system. 1-11, Numbers of distinguished bodies; k_{ij} , interaction coefficients between distinguished bodies.

non-changeable part (elements 3-11) was made. On the basis of the distinguished elements and analysis of the heat processes, the model was determined as shown graphically in Fig. 3. This model was described by a set of eleven differential equations of first-order. The values of coefficients K_i , G_{ij} and G_{i0} of this set of equations are presented in Tables. 1 and 2. They were calculated by the method given in ref. 9. This also concerns the calculations of the thermogram on the basis of the evaluated model. Certainly, this thermogram can also be calculated on the basis of the inverse to the deconvolution procedure discussed before (Fig. 1). In Fig. 4 comparison of the calculated and experimental values was made, giving a good agreement. Then the transmittance of this model was elaborated. The values of constants M_n and L_k obtained were: $M_1 = 532.5$ s, $M_2 = 26.61$ s, $M_3 = 22.02$ s, $M_4 = 21.24$ s, $M_5 = 12.71$ s, $M_6 = 8.55$ s, $M_7 = 2.46$ s, $M_8 = 0.564$ s, $M_9 = 0.328$ s, $M_{10} = 0.063$ s, $M_{11} = 0.006$ s; $L_1 = 112.71$ s, $L_2 = 24.49$ s, $L_3 = 19.76$ s, $L_4 = 2.46$ s, $L_5 = 0.069$ s. The values of M_1 and M_2 were compared with the experimental values of these time constants, which are equal to: $M_{1,exp} = 529.8$ s, $M_{2,exp} = 23.4$ s, also giving a good accordance.

As can be seen from the values of constants M_n and L_k of the determined transmittance, accepting the stability conditions of numerical solution, it would be necessary to use in experiments the value of the sampling period

TABLE 1

Values of the heat capacities (copper-block calorimetric vessel)

i	$K_i(\text{J K}^{-1})$	i	$K_i(\text{J K}^{-1})$	i	$K_i(\text{J K}^{-1})$	i	$K_i(\text{J K}^{-1})$
1	2.253	4	7.321	7	0.018	10	1.577
2	32.26	5	1.546	8	0.483	11	5.142
3	10.07	6	0.874	9	17.432		

smaller than the smallest time constant, that is, $h < M_{11}$. In the series of experiments carried out, according to the frequency characteristics of the calorimetric system and the level of precision of measurements, differentiation of temperature changes was acceptable when the sampling period was equal to at least 5 s. This value is bigger than the following constants of the transmittance: M_6 — M_{11} , L_4 and L_5 . Thus, the condition of stability of numerical solution is not fulfilled. This is why we received unstable results in determination of thermokinetics. Additionally, we made repeatable tests using the inverse filter method [10]. The results obtained by this method, using the whole form of transmittance, were much worse than in the case where terms of transmittance with values of M_n and L_k smaller than h were neglected. This way of approaching the problem, used in inverse filter and analogue correction methods, causes, in practice, part of the information on the dynamics of the system to be lost and, as a result, less accurate reproduction of the thermokinetics is obtained. The method proposed creates a possibility of avoiding these inconveniences by formulating the model based on all the physical parameters of the system but in a different number of distinguished bodies, if the assumption of homogeneous temperature of the bodies is maintained.

From the eleven-elements model (Fig. 3) a seven-bodies model was

TABLE 2

Values of heat loss coefficients (copper-block calorimetric vessel)

i, j	G_{ij}	i, j	G_{ij}	i, j	G_{ij}	i, j	G_{ij}
1,0	0.0025	8,0	0.04079	3,6	12.401	5,7	3.031
2,0	0.00089	9,0	6.958	3,8	0.0289	5,8	0.0037
3,0	0.00415	11,0	0.162	3,9	0.0617	6,8	0.1453
5,0	0.01912	1,2	0.085	3,10	0.0107	9,11	0.0536
6,0	0.00057	2,3	0.9008	4,5	0.1233	10,11	0.0139
7,0	0.00002	2,6	0.00104	4,8	0.016	5,10	0.003
		3,4	7.559				

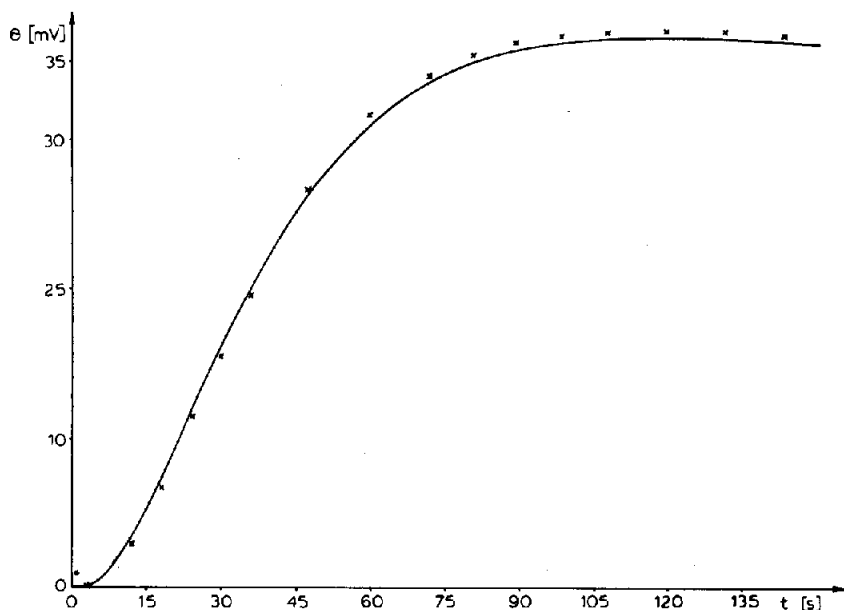

Fig. 4. Calculated and experimental thermograms. —, Experimental thermogram; $\times \times \times \times$, calculated thermogram.

elaborated. The changeable part remained the same (bodies 1 and 2). Bodies 3, 4 and 6 were combined into an element of heat capacity $K_3 = 18.265 \text{ J K}^{-1}$; bodies 5 and 7 into a body of heat capacity $K_4 = 1.578 \text{ J K}^{-1}$; body 9 was joined to the thermostat. Body 8 became number 5; bodies 10 and 11 became 6 and 7 respectively. The new values of G_{i0} and G_{ij} were: $G_{30} = 0.062 \text{ W K}^{-1}$, $G_{40} = 0.0191 \text{ W K}^{-1}$, $G_{50} = 0.0408 \text{ W K}^{-1}$, $G_{70} = 0.162 \text{ W K}^{-1}$, $G_{34} = 0.1213 \text{ W K}^{-1}$, $G_{35} = 0.0189 \text{ W K}^{-1}$, $G_{36} = 0.1107 \text{ W K}^{-1}$, $G_{45} = 0.0037 \text{ W K}^{-1}$, $G_{46} = 0.0031 \text{ W K}^{-1}$, $G_{67} = 0.0139 \text{ W K}^{-1}$. For this model the values of heat capacities and coefficients G_{12} and G_{23} had the values: for the calorimetric vessel made as a copper block, $K_1 = 2.259 \text{ J K}^{-1}$, $K_2 = 32.26 \text{ J K}^{-1}$, $G_{12} = 0.085 \text{ W K}^{-1}$, $G_{23} = 0.9008 \text{ W K}^{-1}$; for a copper calorimetric vessel filled with water, $K_1 = 40.39 \text{ J K}^{-1}$, $G_{12} = 0.3528 \text{ W K}^{-1}$, $G_{23} = 0.9008 \text{ W K}^{-1}$. The determined transmittance, in the first case (copper-block calorimetric vessel), was characterized by the constants: $M_1 = 537.94 \text{ s}$, $M_2 = 29.52 \text{ s}$, $M_3 = 25.42 \text{ s}$, $M_4 = 15.45 \text{ s}$, $M_5 = 11.32 \text{ s}$, $M_6 = 8.63 \text{ s}$, $M_7 = 7.56 \text{ s}$, $L_1 = 29.63 \text{ s}$, $L_2 = 12.04 \text{ s}$, $L_3 = 7.63 \text{ s}$. In the second case, using a calorimetric vessel with water, the values of the transmittance constants were: $M_1 = 642.83 \text{ s}$, $M_2 = 36.01 \text{ s}$, $M_3 = 29.25 \text{ s}$, $M_4 = 12.57 \text{ s}$, $M_5 = 9.72 \text{ s}$, $M_6 = 7.58 \text{ s}$, $L_1 = 29.63 \text{ s}$, $L_2 = 12.04 \text{ s}$, $L_3 = 7.63 \text{ s}$. This model was applied for determination of the thermokinetics of heat effects generated in the calorimeter. The results are presented graphically in Fig. 5. In the case of the copper-block calorimetric vessel, Fig. 5 shows the experimental re-

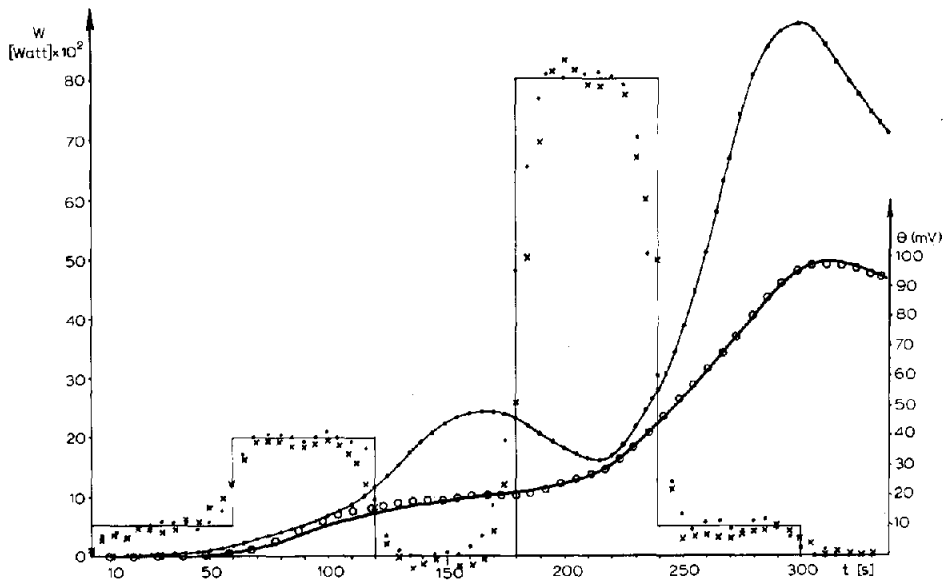

Fig. 5. Reconstruction of heat pulses. ———, Schematic representation of generated pulses; ———, experimental thermogram (copper-block calorimetric vessel); ○ ○ ○, calculated thermogram (copper-block calorimetric vessel); ● - ● - ●, analogue correction of thermogram (copper-block calorimetric vessel); ● ● ●, determination of thermokinetics multi-body method (copper-block calorimetric vessel); × × ×, determination of thermokinetics multi-body method (calorimetric vessel with water).

sponse of the calorimetric system to the generated pulses, reconstructed by the multi-body method thermogram, determination of thermokinetics by the multi-body method, and analogue correction of the thermogram. In the case of the calorimetric vessel with water, Fig. 5 shows the determination of thermokinetics by the multi-body method. The generated pulses, common for both experiments, are also shown. For determination of thermokinetics by the multi-body method, the set of differential equations, which describes the system, was used. In calculations the sampling period was equal to 5 s. In analogue correction of the thermograms, the bigger constants, M_1 and L_1 , were used. The courses of the reconstructed input function $W(t)$ indicate that the multi-body method gives much better results than the analogue correction of thermograms. The multi-body method reconstructs the shape and localization of the pulses in a satisfactory way. The results of determination of thermokinetics for the calorimetric vessel with water are worse (overshoots) than for the copper-block vessel. This is an effect of bigger measurement noise in the experiments with the vessel filled with water. In this case, for calculations of thermokinetics, the algorithm given previously was used. The parameters of the copper-block calorimetric vessel were replaced by the parameters of the vessel with water. These parameters are the input data for the multi-body method program. Thus, this change does

not require any new calibration measurements. These results show that, once determined, this model of the calorimetric system can be used for various contents of the calorimetric vessel, which is important in calorimetric measurements of the heat effects of various chemical reactions.

The course of the reconstructed pulses differs from the shape of the pulses, especially in the points of amplitude changes. This results from the approximation of derivatives and separation of the course of the thermogram into discrete steps. Comparison of experimental and calculated thermograms gives good accordance. That leads to a conclusion that the multi-body method can be used for calculations of the calorimetric response to any heat effect.

ACKNOWLEDGEMENT

This work was supported by the Polish Academy of Sciences.

REFERENCES

- 1 J. Duclaux, *C. R. Acad. Sci.*, 146 (1908) 120.
- 2 W. Świątosławski, *Microcalorimetry*, Reinhold, New York, 1946.
- 3 E. Calvet and H. Prat, *Microcalorimétrie*, Masson, Paris, 1956.
- 4 W. Zielenkiewicz, *Proc. 6th Int. Conf. Chem. Thermodyn.*, Merseburg, 1980, Pergamon Press, Oxford, 1981, p. 219.
- 5 E. Cesari, P.C. Gravelle, J. Gutenbaum, J. Hatt, J. Navarro, J.L. Petit, R. Point, V. Torra, E. Utzig and W. Zielenkiewicz, *J. Ther. Anal.*, 20 (1981) 47.
- 6 E. Margas and W. Zielenkiewicz, *Bull. Acad. Pol. Sci. Ser. Chim.*, 26 (1978) 503.
- 7 E. Jury, *Theory and Application of Z-Transform Method*, Wiley, New York, 1964.
- 8 M. Lewandowski and S. Randzio, *Apar. Nauk. Dyd.*, 4 (6) (1978) 45.
- 9 E. Cesari, J. Hatt, E. Margas, J. Navarro, V. Torra, E. Utzig and W. Zielenkiewicz, *Bull. Acad. Pol. Sci. Ser. Chim.*, 28 (1980) 297.
- 10 R. Point, J.L. Petit and P.C. Gravelle, *J. Therm. Anal.*, 11 (1977) 431.