

THERMAL ANALYSIS OF MONOTHIOCARBONOHYDRAZONES

G. RAJENDRAN and S.R. JAIN *

Propellant Chemistry Laboratory, Department of Aerospace Engineering, Indian Institute of Science, Bangalore 560 012 (India)

(Received 16 July 1984)

ABSTRACT

Thermal analysis of monothiocarbonohydrazones carried out using DTA and TG techniques show that they all decompose exothermally soon after melting. The exothermal decomposition is attributed to the presence of a hydrazino (N–N) bond. The decomposition process has been studied by examining the products of decomposition of benzaldehydethiocarbonohydrazone. Nitrogen, ammonia, hydrogen sulphide, benzonitrile, thiobenzaldehyde, 2,4,6-triphenyl-s-triazine and complex condensation products containing C=N linkages, have been found to be the main products of decomposition. A probable mechanism of decomposition is proposed based on the formation of these products, assuming the homolytic cleavage of the N–N bond as a primary step.

INTRODUCTION

While searching for suitable solid fuels for hybrid propellants which ignite instantaneously upon contact with a liquid oxidizer, several monothiocarbonohydrazones, the condensation products of thiocarbonohydrazide with aldehydes and ketones were examined [1,2]. A survey of the literature reveals that although these compounds have been used extensively to synthesize various derivatives of different heterocyclic compounds [3–6] and found to act as fungicides [7], there is virtually no study reported so far pertaining to their thermal characterization and behaviour. For information concerning the thermal behaviour pertinent to our on-going studies, we examined the thermo-analytical behaviour of thiocarbonohydrazones and related compounds in detail using differential thermal analysis (DTA) and thermogravimetry (TG) techniques, the results of which are reported in this paper.

* Author to whom correspondence should be addressed.

EXPERIMENTAL

Materials

Thiocarbonohydrazide (TCH) was prepared [8] from carbon disulphide and hydrazine hydrate. The monothiocarbonohydrazone were prepared [2] by adding an alcoholic solution of the appropriate aldehyde or ketone to a well-stirred, hot 1 N acetic acid solution containing an equimolar amount of thiocarbonohydrazide. The compounds were characterized by their elemental analyses, melting points, and IR and ^1H NMR spectra.

Thermal studies

DTA was carried out using a set-up described earlier [9]. In each experiment, 100 mg of the sample were taken in the DTA cup and heated at a uniform rate of $10^\circ\text{C min}^{-1}$. For some of the samples, the DTA was also carried out in a flowing nitrogen atmosphere (30 ml min^{-1}). TG analysis data were recorded on a Stanton-Redcroft model TG-750 thermobalance, using 10 mg of the sample, at a heating rate of $10^\circ\text{C min}^{-1}$.

The IR spectra of various samples were recorded on a Perkin-Elmer 599 spectrophotometer. The gaseous samples (products of decomposition) were analysed using a gas cell with KBr windows.

The ^1H NMR spectra were recorded on a Varian T-60 machine at 36°C using $\text{DMSO-}d_6$ as the solvent. The NH proton signals were confirmed by D_2O exchange spectra.

The gaseous products of decomposition were analysed on a Aimil Nucon-5500 gas chromatograph using carbowax coated with 5% KOH and molecular sieve 5A columns.

Decomposition product analysis

In order to examine the decomposition products, benzaldehydethiocarbonohydrazone (BTCH) was taken in a sublimation tube and attached to a glass assembly as shown in Fig. 1. After having flushed the assembly well with helium gas, the sample was carefully heated on an oilbath maintained at 200°C until the compound melted completely to give a clear liquid. The compound decomposed simultaneously as evidenced by the evolution of gases. The gaseous products were collected by sealing the gas flask with a rubber septum. At the end of the experiment, a deposition of white crystals was observed in the condenser which sublimed rapidly in air at room temperature. The crystals were identified to be ammonium hydrosulphide [10]. The viscous liquid residue in the sublimation tube was mixed with some glass powder and extracted on a Soxhlet, separately with hexane, chloroform and methanol for 6 h each.

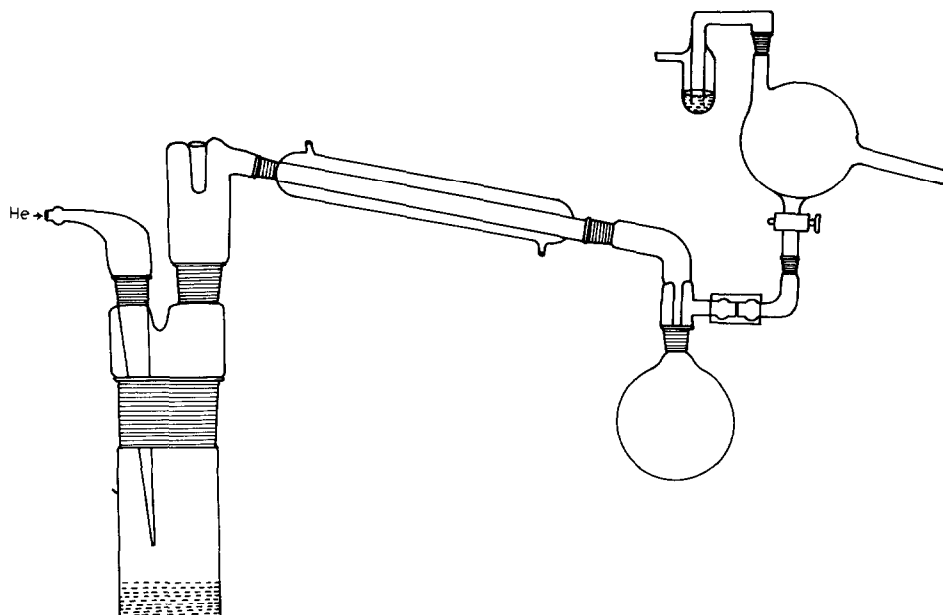

Fig. 1. Glass assembly for collecting the products of decomposition.

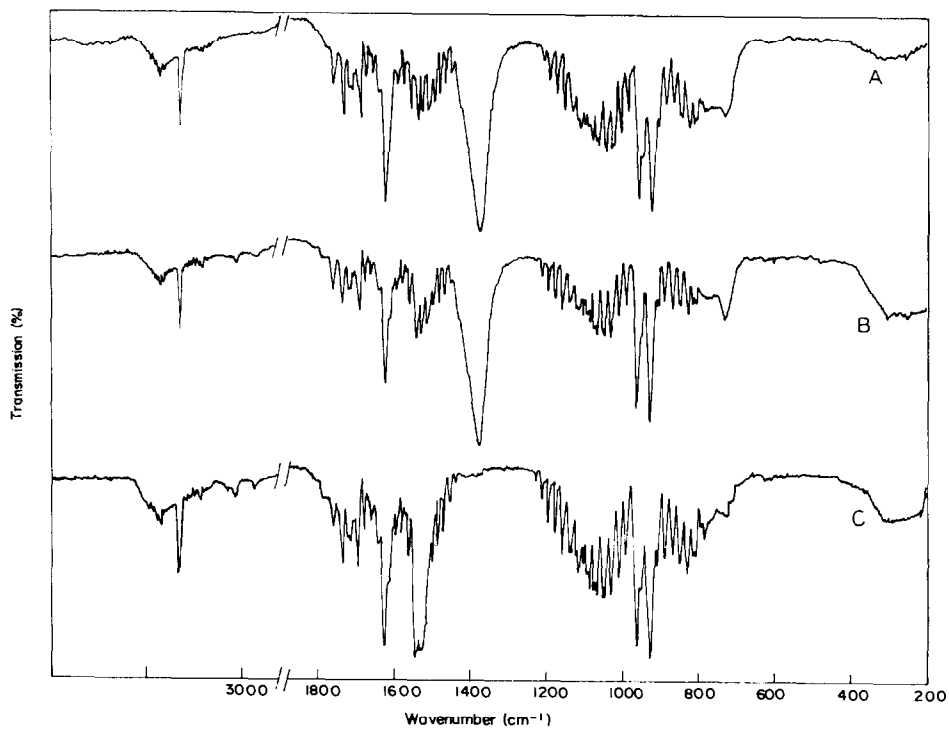

Fig. 2. IR spectra of gaseous products of decomposition: (A) authentic sample of a mixture of NH_3 and H_2S ; (B) gaseous products of decomposition in 0.5 h; (C) after 48 h.

Gaseous products

The gaseous products were identified by gas chromatography (GC) and IR spectroscopy. Using helium as carrier gas, the products identified by GC were nitrogen, ammonia and hydrogen sulphide. The IR spectra of the gaseous products presented in Fig. 2 also provide clear evidence for the presence of NH_3 and H_2S . It may be pointed out here that gaseous H_2S has rather a strong absorption around 1360 cm^{-1} and not a weak one as reported by Pierson et al. [11]. The IR spectrum of the gaseous products shows considerable modification when recorded after 48 h (Fig. 2). The strong absorption at 1360 cm^{-1} completely disappears with some modification in the $1500\text{--}1550\text{ cm}^{-1}$ region. The gaseous hydrogen sulphide apparently reacts with ammonia which subsequently decomposes as evidenced by the deposition of a yellow substance as a thin coating all over the inside wall of the gas flask.

In order to detect the presence of hydrogen gas, the decomposition

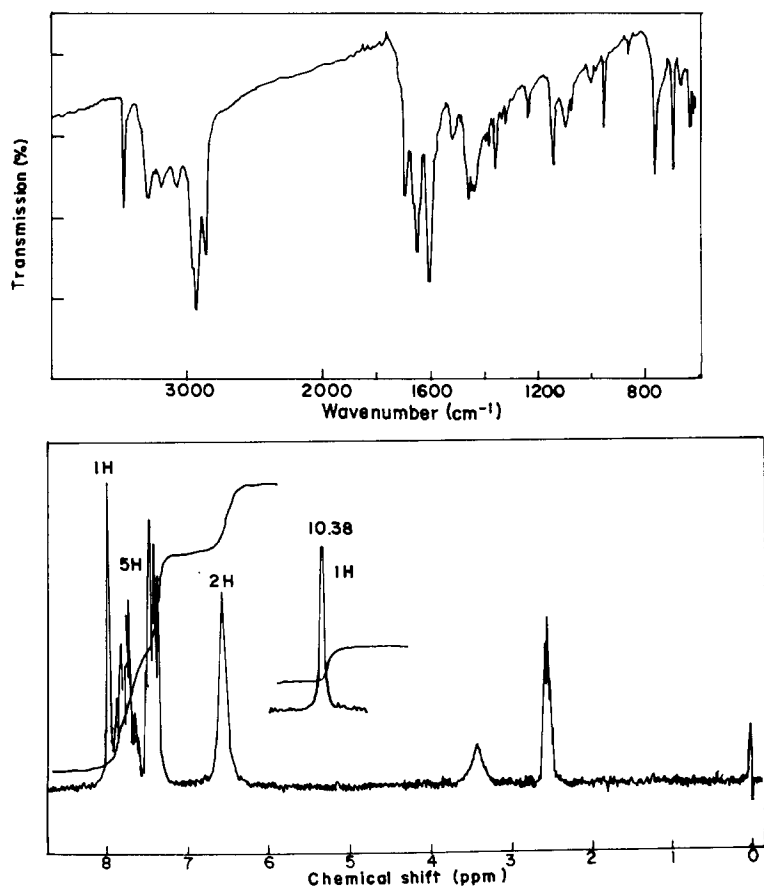

Fig. 3. IR and NMR spectra of benzaldehydesemicarbazone.

products collected in another experiment wherein BTCH was decomposed under nitrogen atmosphere, were examined by GC using N_2 as the carrier gas. There was, however, no evidence for the presence of hydrogen in any significant amount.

Hexane extract

The residue obtained after evaporating the solvent on a water bath on cooling separated into a pale yellow liquid and a colourless crystalline solid. The solid was filtered, washed with ice-cold hexane, and dried; m.p. $82^\circ C$. A qualitative elemental analysis of the solid residue showed the presence of sulphur and it gave a red-orange precipitate with 2,4-dinitrophenylhydrazine, indicative of the presence of a carbonyl or thiocarbonyl group. A portion of the solid residue was reacted with semicarbazide hydrochloride and the crystalline product obtained was identified to be benzaldehydesemicarbazone, from its melting point (observed, $223^\circ C$; lit., $224^\circ C$), and IR and NMR spectra presented in Fig. 3. The solid component, therefore, was identified as thiobenzaldehyde (trimer); the lower melting point, $82^\circ C$, being due to the presence of both the α and the β forms [12]. The liquid

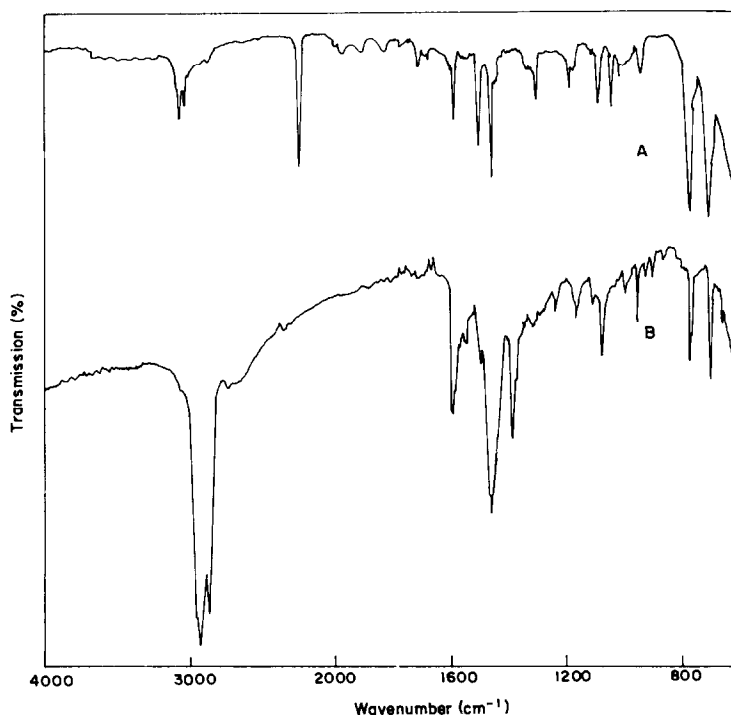

Fig. 4. IR spectra of products isolated from hexane and chloroform extracts; (A) benzonitrile; and (B) 2,4,6-triphenyl-*s*-triazine.

component was purified by micro-distillation, b.p. 186–188°C. The IR spectrum of the distillate was exactly identical to that reported for benzonitrile [13] as shown in Fig. 4.

Chloroform extract

The solvent chloroform was evaporated on a water bath. A highly viscous but clear residue was obtained. The TLC of the residue showed three spots on eluting with chloroform containing 1% methanol. By means of preparative TLC, one of the components, in major proportion, was identified to be 2,4,6-triphenyl-*s*-triazine from its melting point (observed, 234°C; lit., 235°C). The IR spectrum of this compound presented in Fig. 4 matched well with that given in the Sadtler spectral report [13]. The other two spots being in negligibly minute amounts could not be identified with certainty.

Methanol extract

The extract on evaporation of methanol gave a greyish solid residue. The TLC of the residue, using chloroform containing 5% methanol as eluent, showed two major spots. The IR spectra (Fig. 5) of both of these have absorptions around 3370, 3300 and 3160 cm^{-1} but they differ in intensity. These could be ascribed to NH stretching. The strong absorptions at 1650 cm^{-1} in both the products suggest the presence of a C=N group. The

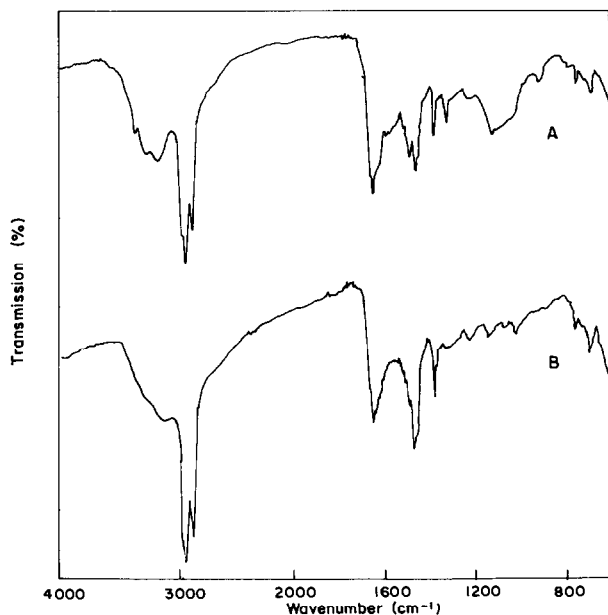

Fig. 5. IR spectra of products isolated from methanol extract.

compounds melt over a range of temperatures (86–102 and 71–89°C) and qualitative tests showed them to be non-aromatic containing nitrogen. Based on these results, it appears that these products could be complex polymeric products having C=N, NH and/or NH₂ groups.

RESULTS AND DISCUSSION

The DTA and TG data of thiocarbonohydrazones and related compounds are listed in Table 1. Each of the typical thermograms of thiocarbonohydrazones presented in Fig. 6 shows an endotherm due to melting followed immediately by an exotherm. That the exotherm in all these cases is due to decomposition of the compound, is shown by the corresponding weight loss in TG. Both the melting and the decomposition processes occur within a range of 10°C in most of these cases. Although these thiocarbonohydrazones are known to exist in linear and cyclic configurations [2], this feature appears to be common. In order to ascertain that the exotherm immediately

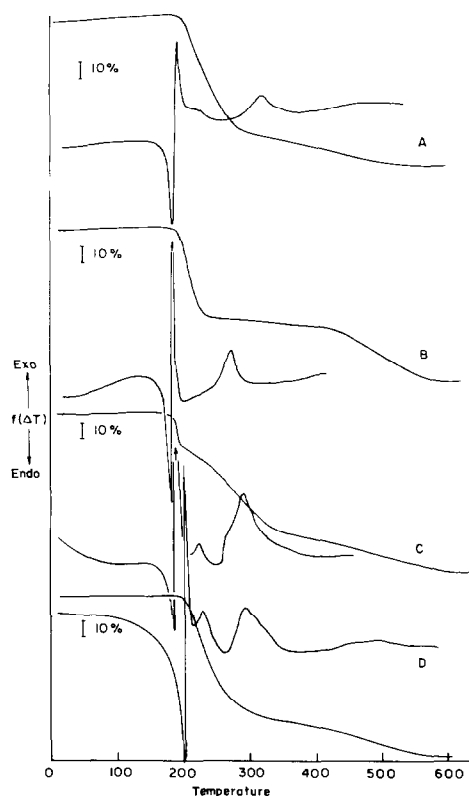

Fig. 6. DTA and TG curves of some typical thiocarbonohydrazones of: (A) benzaldehyde; (B) 2-furaldehyde; (C) formaldehyde; and (D) acetone.

TABLE 1
Thermal analysis data of thiocarbonohydrazones and related compounds

No.	Compound	DTA		TG	%Wt loss
		peak temperatures (°C)			
1	Benzaldehydethiocarbonohydrazone $C_6H_5CH:NNHC:SNHNH_2$	198(-)	206(+)	325(+)	72
2	<i>p</i> -Hydroxybenzaldehydethiocarbonohydrazone $p-(OH)C_6H_4CH:NNHC:SNHNH_2$	197(-)	205(+)	in N_2	94
		220(-)	228(+)		48
3	<i>p</i> -Methoxybenzaldehydethiocarbonohydrazone $p-(OCH_3)C_6H_4CH:NNHC:SNHNH_2$	196(-)	207(+)	315(+)	74
4	<i>p</i> -Dimethylaminobenzaldehydethiocarbonohydrazone $p-(N(CH_3)_2)C_6H_4CH:NNHC:SNHNH_2$	184(-)	192(+)	260(+)	310(+)
		187(-)	194(+)	in N_2	57
5	<i>p</i> -Chlorobenzaldehydethiocarbonohydrazone $p-ClC_6H_4CH:NNHC:SNHNH_2$	194(-)	203(+)		75
6	<i>p</i> -Nitrobenzaldehydethiocarbonohydrazone $p-NO_2C_6H_4CH:NNHC:SNHNH_2$	220(-)	230(+)		97
		177(-)	185(+)	290(+)	68
7	Acetophenonethiocarbonohydrazone	176-	280		

8	$C_6H_5CCH_3:NNHC:SNHNH_2$ 2-Furaldehydethiocarbonohydrazone	186(-) 196(+) 285(+)	340-660	96
9	$C_4H_3OCH:NNHC:SNHNH_2$ Cyclohexanonethiocarbonohydrazone (CH_2) ₅ CNHNHC:SNHNH	169(-) 179(+)	427-660 169-322 405-616	53 96 79 99
10	Formaldehydethiocarbonohydrazone <u>CH₂NHNHC:SNHNH</u>	181(-) 188(+) 221(+) 285(+)	176-191 206-322 365-623	21 69 97
11	Acetonethiocarbonohydrazone (CH_3) ₂ CNHNHC:SNHNH	201(-) 210(+) 233(+) 290(+)	199-305 324-566	73 96
12	Butanonethiocarbonohydrazone (C_2H_5)CH ₂ CNHNHC:SNHNH	135(-) 183(+) 203(+)	136-293 316-590	73 98
13	Thiocarbonohydrazide NH ₂ NHC:SNHNH ₂	174(-) 177(+) 305(+) 400(+)	176-186 200-600	58 99
14	Thiosemicarbazide NH ₂ C:SNHNH ₂	186(-) 194(+) 260(+) 282(+)	184-315 375-540	82 100
15	Thiourea NH ₂ C:SNH ₂	178(-) 262(-)	179-280	96

following the melting point is due to decomposition and not due to aerial oxidation, the DTA of some of the samples was carried out in an atmosphere of nitrogen, wherein no significant change either in the decomposition temperature (Table 1) or the magnitude of the exothermicity was noted. Only the complex exotherms observed above 300°C are apparently due to aerial oxidation.

The height of the decomposition exotherms following the melting points, shows significant variation in different thiocarbonohydrazones. In general, the aliphatic aldehyde and ketone thiocarbonohydrazones decompose with higher exothermicity than the aromatic carbonyl derivatives. Among the aliphatic derivatives, the exothermicity decreases in the order

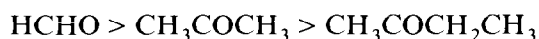

The order observed in the case of aromatic carbonyl derivatives is



The 2-furaldehyde derivative decomposes with much higher exothermicity than any of the aromatic carbonyl derivatives.

The trends in the exothermicity of decomposition apparently show that (i) the exothermicity is related to the percentage of hydrazino (N–N) bond content in the compound, and (ii) the aldehyde derivatives decompose with higher exothermicity than the corresponding ketone derivatives.

In order to show that the exothermic decomposition is due to the presence of N–N bond(s), the DTA of thiocarbonohydrazide was compared with other compounds having similar structures, viz. thiosemicarbazide and thiourea (Fig. 7). It is interesting to note that the DTA of thiourea shows two endotherms at 182 and 252°C corresponding to its melting and boiling points. Thiosemicarbazide having one N–N bond, on the other hand, decomposes exothermally soon after melting analogous to thiocarbonohydrazide, which, having two N–N bonds, decomposes with relatively higher exothermicity than that of thiosemicarbazide. Thus, it becomes evident that the exothermal decomposition in these compounds is related to the presence of N–N bonds. It may be envisaged that the exothermicity of overall decomposition being related to the difference in energetics of the bonds present in the products and the reactant, the formation of the highly stable molecule $\text{N}\equiv\text{N}$ as a product, may be responsible for the decomposition process to be exothermal.

The TG data show that all the thiocarbonohydrazones start losing weight just around their melting points. The weight loss is rapid in the initial stage but it continues up to 50–75%. A charry residue remains in most cases at this stage. The compounds lose more than 95 wt% apparently due to aerial oxidation on further heating to 600°C.

The TG of thiosemicarbazide is similar to that of thiocarbonohydrazide; it begins to lose weight around its melting point. The TG of thiourea shows

that it starts evaporating, losing weight above its melting point continuously until the weight loss is about 96%.

In order to understand the mode of decomposition, the products of decomposition of a typical compound, namely benzaldehydethiocarbonohydrazone were analysed. The N–N bond being the weakest, the decomposition process in all these compounds may be initiated by the homolytic cleavage of this bond. The major products of decomposition of benzaldehydethiocarbonohydrazone are found to be N₂, NH₃, H₂S, benzonitrile, thiobenzaldehyde, trimeric product of benzonitrile, viz., 2,4,6-triphenyl-*s*-triazine, and complex condensation products having C=N and NH linkages. Based on these products the following steps in the decomposition process seem plausible.

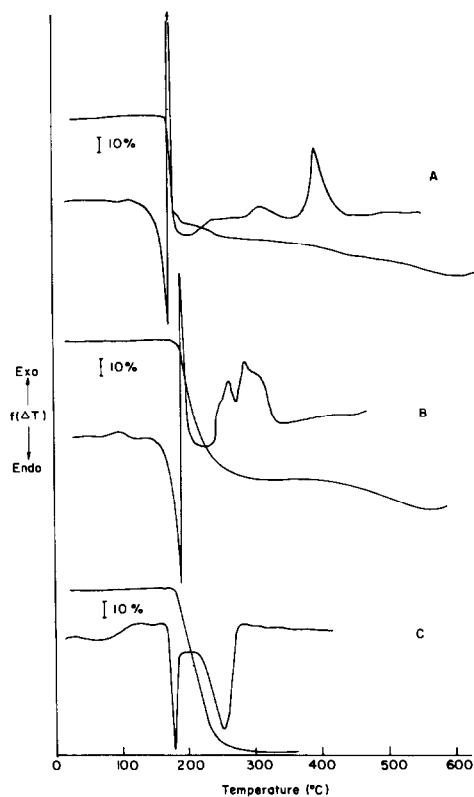
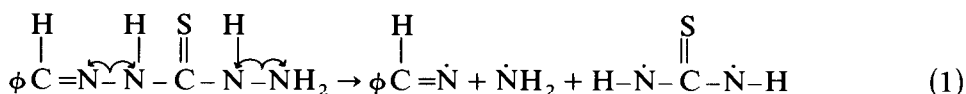
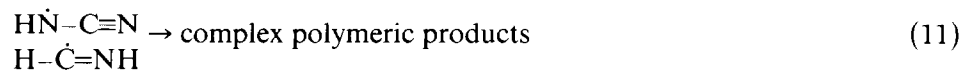
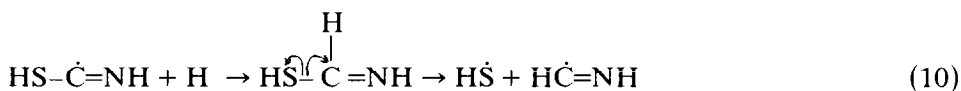
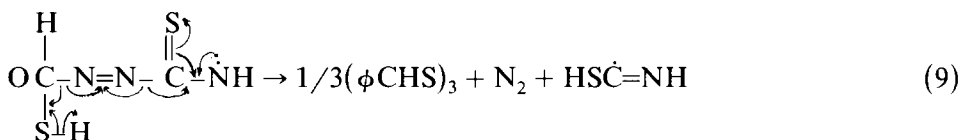
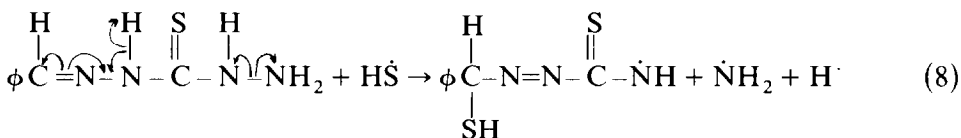
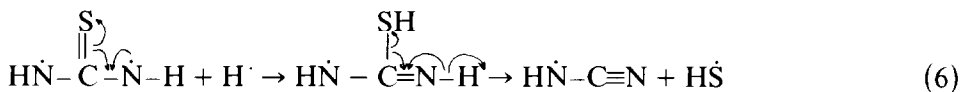
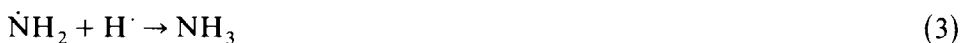
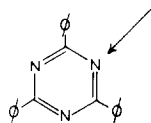

Fig. 7. DTA and TG curves of: (A) thiocarbonohydrazone; (B) thiosemicarbazide; and (C) thiourea.



The homolytic scission of the N–N bonds results in the formation of benzalimino, amino radicals and a biradical (step 1). The substituted imino radicals are known to cleave into nitriles [14] and therefore, in the present case, it is likely that the benzalimino radical forms benzonitrile and its trimer (step 2). The amino radical may combine with a hydrogen radical [15] or disproportionate into ammonia and an imino radical which disproportionates further into nitrogen and ammonia [16] (steps 3–5). The biradical being a highly reactive species might quickly undergo rearrangement leading to the formation of a cyanamidyl and a mercaptyl radicals (step 6). The latter may combine with a hydrogen radical to form hydrogen sulphide (step 7). The mercaptyl radical, known for its reactivity with multiple bonds [17], may attack the parent molecule resulting in the formation of thiobenz-

aldehyde trimer (step 9), via an intermediate as shown in step (8). It is likely that the mercaptoformiminyl radical formed in step (9) may combine with a hydrogen radical which subsequently results in the formation of formiminyl radical as shown in step (10). The cyanamidyl radical (step 6) and formiminyl radical may then condense to form complex polymeric products having C=N and NH linkages. However, the mechanism of the last two steps remains uncertain.

REFERENCES

- 1 G. Rajendran and S.R. Jain, *Fuel*, 63 (1984) 709.
- 2 G. Rajendran and S.R. Jain, *Org. Magn. Reson.*, 22 (1984) 6.
- 3 J. Sandström, *Acta Chem. Scand.*, 14 (1960) 1037, 1939; 15 (1961) 1295; 17 (1963) 1595.
- 4 R. Stolle and P.E. Bowles, *Chem. Ber.*, 41 (1908) 1099.
- 5 H. Beyer, W. Lassig and V. Schultz, *Chem. Ber.*, 87 (1954) 1401.
- 6 P.C. Guha and S.C. Dey, *J. Indian Chem. Soc.*, 1 (1924) 145.
- 7 D.M. Wiles and T. Suprunchuk, *J. Med. Chem.*, 13 (1970) 323.
- 8 L.F. Audrieth, E.S. Scott and P.S. Kippun, *J. Org. Chem.*, 19 (1954) 733.
- 9 S.R. Jain, M.V. Rao and V.R. Pai Verneker, *J. Chem. Soc., Perkin Trans. 2.* (1979) 406.
- 10 G. Brauer (Ed.), *Handbook of Preparative Inorganic Chemistry*, Academic Press, New York, 1965, 2nd edn., Vol. 1, 357 pp.
- 11 R.H. Pierson, A.N. Fletcher and E.St. Clair Gantz, *Anal. Chem.*, 28 (1956) 1218.
- 12 E. Campaigne, *Chem. Rev.*, 39 (1946) 1.
- 13 W.W. Simons (Ed.), *The Sadtler Handbook of IR Spectra*, Heyden, London, 1978, pp. 222, 292.
- 14 M.L. Poutsma and P.A. Ibarbia, *J. Org. Chem.*, 34 (1969) 2848.
- 15 G.H. Williams (Ed.), *Advances in Free-Radical Chemistry*, Logos Press Ltd., London, 1967, Vol. II, p. 10.
- 16 R.A. Back, *J. Chem. Phys.*, 40 (1964) 3493.
- 17 W. Ando, K. Sugimoto and S. Oae, *Bull. Chem. Soc. Jpn.*, 37 (1964) 365.