

RECENT DEVELOPMENTS IN MICROCALORIMETRIC INSTRUMENTATION FOR STUDIES OF BIO-CHEMICAL AND CELLULAR SYSTEMS

I Wadsö

Division of Thermochemistry, Chemical Center, University of Lund, P. O. Box 124,
S-221 00 Lund, Sweden

ABSTRACT

A modular microcalorimetric system is described. A precisely thermostated water bath can hold up to four heat conduction calorimeters. Different types of insertion vessels as well as permanently installed flow vessels (mixing or flow-through) are used. Most recently a new insertion vessel for automatic titrations and for work with living cells has been developed. This vessel is fitted with a stirrer, injection tubes and a counter-current heat-exchanger for "perfusion flow".

INTRODUCTION

Several microcalorimeters of the heat-conduction type have been reported from our laboratory, see e.g. ref. 1. The first instrument in the series was a batch reaction calorimeter (ref. 2) primarily designed for studies of biochemical binding reactions. This instrument was followed by a flow version which was equipped with different types of mixing and flow-through vessels (see e.g. ref. 3). The basic design employed with the batch and the flow instruments was also used in an adsorption calorimeter, in a drop heat capacity calorimeter, and in an instrument where different types of insertion vessels could be introduced via heat-exchange zones. This latter instrument has been used in studies of living cells and, used with special insertion vessels, for the determination of enthalpy of solution of slightly soluble liquids (ref. 4) and gases (ref. 5).

During the work with these instruments it was realized that a further increase in the sensitivity and/or baseline stability would frequently increase their usefulness. Further, in particular in connection with analytical applications, e.g. in cell biology, it would be desirable to have a "multi-channel" instrument available. Another experience was that with a modular design it is possible in practice to obtain widely different calorimetric functions with a comparatively limited number of different mechanical and

electric units. These considerations led us to the design of a new microcalorimetric system (ref. 6). The basic unit consists of a thermostated water bath which can hold up to 4 calorimeters which can be equipped with different types of insertion vessels and with permanently installed flow vessels. As in the earlier series of instruments, the calorimeters are of the heat-conduction type, usually in twin arrangements. The size of the calorimetric heat sinks has been much reduced, which has called for a significantly improved stability of the thermostatic bath. Very recently a new insertion vessel for use with living cells and in titration experiments has been added to the system (ref. 7). Below a brief presentation is made of the instrument system and its use in biochemistry and cell biology.

THE BASIC UNIT

The basic unit consists of a 20 l thermostated water bath and an electric console with amplifiers and units for electrical calibration of the calorimeters and for the control of the bath temperature. The water thermostat is of the overflow type where water is circulated by a centrifugal pump. The temperature is controlled on two levels, in the pump and in the bath outlet tube. Thermistors are used as sensors. The temperature stability (at 37 °C) is $\pm 1 \cdot 10^{-4}$ K over long periods of time (days) if the ambient temperature is stable to within ± 1 K. The water bath can hold up to 4 cylindrically-shaped calorimeters ("channels").

THE CALORIMETRIC CHANNELS

Fig. 1A shows schematically a twin calorimetric channel for use with cylindrical insertion vessels, diameter 14 mm. A cylindrical stainless steel vessel, f, contains an aluminium block assembly which serves as the calorimetric heatsink. This consists of two main cylindrical blocks, h and j, and four small, nearly cubic blocks, i, which are in contact with the thermopile. The twin calorimetric unit, B, consists of two holders for insertion vessels ("ampoule holders"), l. Each ampoule holder is surrounded by two Peltier effect plates, which form thermal bridges to the small aluminium blocks, i. For each ampoule holder, the Peltier effect plates are electrically connected in series, whereas the two thermopiles thus formed are connected in opposition, giving a differential voltage signal from the twin calorimetric unit. The ampoule holders consist of aluminium tubes where the outside of the middle section has a nearly cubic profile in order to ensure a good thermal contact with the thermocouple plates. In the bottom of the aluminium tubes there are bores which contain calibration heaters. Alternatively, the heaters are placed

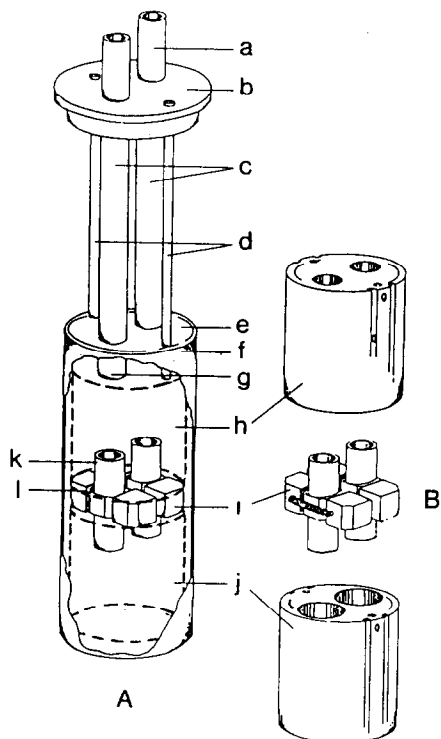

Fig. 1. Twin calorimetric channel used with cylindrical insertion vessels: a, connecting tubes; b, lid, c, 16 mm steel tubes; d, 6 mm steel tubes; e, steel lid; f, steel vessel; g, connecting tubes; h, aluminium block; i, small aluminium block; j, aluminium block, k, ampoule holder.

in vertical bores in the middle section of the ampoule holders. The upper and lower parts of the ampoule holders fit into wide cylindrical bores in the main aluminium blocks. Above the ampoule holders the bores are narrowed to 14 mm in order to give a close fit with the calorimetric insertion vessels. The bores are carefully aligned with the two large steel tubes, *c*, of the lid assembly. These tubes and the narrow parts of the bores serve as heat exchange zones for the insertion vessels. Several types of simple insertion vessels are used: 1, 3 or 5 ml cylindrical steel ampoules closed with screw lids and teflon packings and a commercially available glass vial.

A calorimetric channel used with a single (20 ml) cylindrical ampoule has also been built. In that case one Peltier effect plate is placed on the upper surface of the lower aluminium block. An aluminium cylinder which serves as the ampoule holder rests on the Peltier effect plate.

A twin channel essentially identical to that shown in Fig. 1 has been fitted with 24 K gold tubes (inner diameter 1 mm), forming flow-through and flow-mixing vessels. Parts of the gold tubes are in contact with the water bath, where they serve as pre-heat exchangers. The tubes are then brought in contact

with the aluminium blocks for further equilibration of the flow. The calorimetric vessels consist of spirals wound on threaded aluminium tubes which are in contact with the thermopiles. Except for the threads, these aluminium tubes are identical to the ampoule holders (1) shown in figure 1. They can thus also be used as holders for ampoules and other insertion vessels (diameter 14 mm).

INSERTION VESSELS

In addition to the simple ampoules mentioned above, a more complex vessel fitted with injection tubes and a stirrer was described in ref. 6. This vessel, primarily intended for use with living cells and in titration experiments, has now been developed further (ref. 7). The vessel is shown schematically in Fig. 2 (see next page). It consists of a sample compartment, g, h, which is connected to a steel tube, d. The brass bolts, e and f, serve as thermal shortages to the water bath and to the upper aluminium block, respectively. Inside the steel tube, d, there is a stirrer shaft rotated by a motor, b.

Experiments can be performed with or without liquid perfusing through the vessel, \leq 30 ml/h. The vessel can be equipped with different sample cups, volume 1-3 ml. Small quantities of reagents can be added to the sample compartment during the measurements through the injection tube, a. Different stirrers and sample holders have been developed, including a "turbine stirrer" which can be used with e.g. microcarriers and other suspended materials.

SOME CHARACTERISTIC PROPERTIES OF THE CALORIMETERS

With simple closed ampoules in a twin arrangement (cf. Fig. 1), the baseline stability over a day is typically better than $\pm 0.1 \mu\text{W}$. With the large ampoules in single arrangement, the corresponding figure is about $1 \mu\text{W}$. For the flow channel, the long-term stability is about $\pm 0.1 \mu\text{W}$ at low flow rates (ca. 10 ml/h). At high flow rates (60 ml/h), the baseline shift is still usually very small but short-time fluctuations in the signal are more pronounced, ca. $\pm 0.5 \mu\text{W}$. In comparison with our "old" system (and its commercial version produced by LKB Produkter), the baseline stability, and thus the useful sensitivity, is much improved.

With the new perfusion-titration vessel, the baseline stability is typically $\pm 0.3 \mu\text{W}$ for several hours at a stirring rate of 50 r.p.m. and with a perfusion rate of \leq 20 ml/h. The vessel can be used as a precise titration calorimeter (ref. 7). By use of a motor-driven syringe, μl quantities of titrant are added through the injection needle, k (Fig. 2). Time and volumes of the injections are regulated by a computer which is also used for integration of the titration curves. In a typical protein ligand binding experiment, $0.2 \mu\text{mol}$ of protein is adequate for a binding curve

from which both ΔG^0 and ΔH^0 can be evaluated.

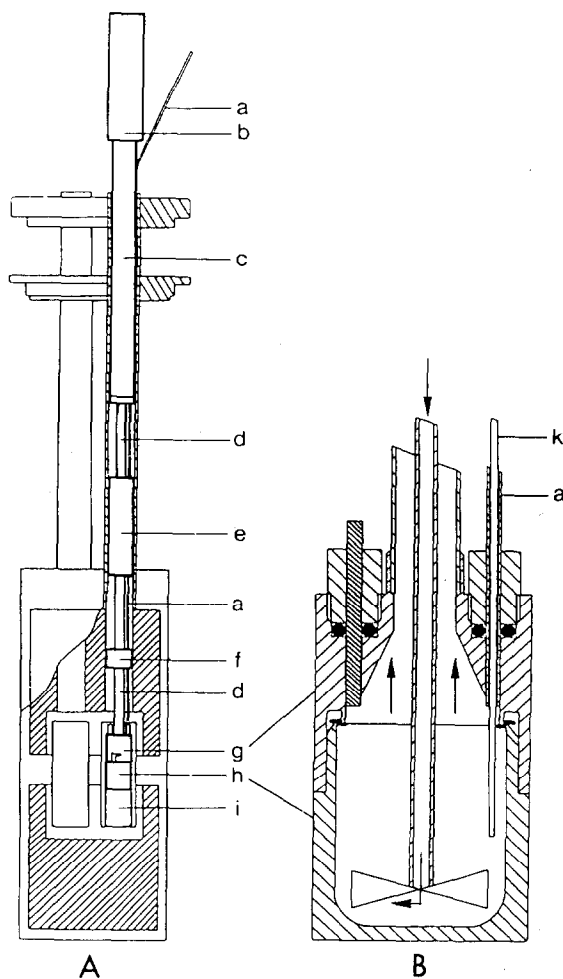

Fig. 2 A, simplified picture of the perfusion-titration vessel shown in measurement position. B, section through the sample compartment. a, titration tube; b, stirrer motor; c, plastic tube; d, steel tube; e, f, brass bolts; g, h, sample compartment; i, aluminium cylinder, k, injection needle.

Examples of the use of this vessel for measurements with cultured tissue cells in suspension (lymphoma cells) and attached to a polystyrene film

(melanoma cells) are given in ref. 7. These studies are progress, as well as measurements on human muscle fibres (ref. 8). In this latter case, the sample is kept in a rotating perforated cage while medium is perfused through the vessel.

Further development of the calorimetric system is in progress. It is expected that most of the functions of our "old" system will be incorporated. A commercial version of the 4-channel system is marketed by LKB Produkter (LKB "BioActivity Monitor").

REFERENCES

1. C. Spink and I. Wadsö, in D. Glick (Ed.), *Methods of Biochemical Analysis*, John Wiley and Sons, New York, 1976, pp. 1-160.
2. I. Wadsö, *Acta Chem. Scand.*, 22 (1968), 927-937.
3. I. Wadsö, in A. Beezer (Ed.), *Biological Microcalorimetry*, Academic Press, London, 1980, pp.247-274.
4. S.-O. Nilsson and I Wadsö, *J. Chem. Thermodynamics*, 16 (1984), 317-330.
5. S. J. Gill and I. Wadsö, *J. Chem. Thermodynamics*, 14 (1982), 905-919.
6. J. Suurkuusk and I. Wadsö, *Chemica Scripta*, 20 (1982), 155-163.
7. M. Görman-Nordmark, J. Laynez, A. Schön, J. Suurkuusk, and I. Wadsö, *J. Biochem. Biophys. Methods*, in press.
8. B. Fagher, M. Monti and I. Wadsö, to be published.