

RADIATION THERMOMETRY AS AN APPROPRIATE METHOD TO OBSERVE THE  
OXIDE GROWTH ON METAL-SURFACES

G. Neuer, F. Güntert and B. Wörner

Institut für Kernenergetik und Energiesysteme (IKE), University  
of Stuttgart, Postfach 80 11 40, D-7000 Stuttgart 80, Federal  
Republic of Germany

ABSTRACT

The radiation measurement technique to investigate the variation of the emittance of metals during oxidation processes is shortly described. The oxidation time can be varied between one second and several minutes. Results of the total emittance and spectral emittance at wavelengths 0.71, 0.85 and 1.0  $\mu\text{m}$  on steel type 1.4016 at  $\sim 1000$  °C are presented. Primarily the values serve to correct pyrometrically measured temperatures or to find out suitable wavelength combinations for ratio pyrometry. The interference effects of this layers enable us additionally to use the method to observe the oxide growth.

INTRODUCTION

The radiative properties of metals are strongly influenced by the condition of its surface. Two effects are to be distinguished which can lead to the change of the emittance: cavity effects and changes in the materials. The influence of roughness is fully described in the literature and theoretical models could be proved by our own systematic measurements (ref. 1). Among the changes in the material oxidation is most important. Oxide layers on metal surfaces can lead to an increase of the emittance by a factor of up to 3 to 10. In the range of thickness where the layers are translucent the change of the spectral emittance is extremely dependent on the wavelength. This effect is well known from the temper colours. This behaviour causes remarkable uncertainties in the radiation thermometry if temperatures are measured on objects forming surface oxides during measurements. In practice this occurs

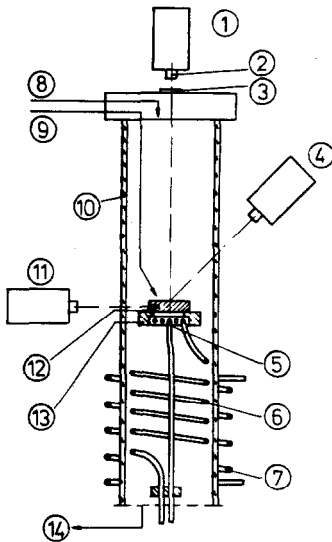

Fig. 1. Emittance measurement device schematic

- 1 total radiation detector
- 2  $\text{CaF}_2$ -lens
- 3  $\text{CaF}_2$ -window
- 4 spectral radiation detectors
- 5 flat coil
- 6 secondary coil
- 7 primary coil
- 8 inert gas inlet
- 9 oxidizing gas inlet
- 10  $\text{SiO}_2$  tube (70/60 mm diameter)
- 11 temperature measurement and control pyrometer
- 12 sample
- 13 ceramic sample holder
- 14 gas outlet

at the hot rolling and thermal treatments of steel or other metals is in an oxidizing atmosphere. The spectral emittance of a metal surface shows maxima and minima when the oxide-film is growing up, the position of them depends on the wavelength. If the optical constants (index of refraction and extinction coefficient) both of the oxide film and of the substrate are known the spectral emittance-vs-thickness can be calculated (Fig. 3).

### Experiments

The radiation comparison method is used to measure the spectral and total emittance between 500 °C and 1100 °C. The sample which is 30 mm in diameter and 2-5 mm in thickness is heated up to a chosen temperature in an inert atmosphere by induction from a special coil arrangement as shown in Fig. 1. Then - keeping its temperature constant - the sample is exposed to an oxidizing gas for a preset time between one second and several minutes. For temperature measurement and control a high precision standard pyrometer (ref. 2) is sighted onto a cavity of 1 mm diameter. The spectral radiation detectors are mounted at an angle of  $\sim 45^\circ$  and the total radiation detector is sighted vertically onto the sample surface. Special attention must be devoted to the careful calibration of the radiation detectors. Therefore a heat pipe blackbody was built for using as reference radiator (ref. 3) which realize an isothermal cavity in the best possible way, resulting in an effective emittance better than 0.998. Further

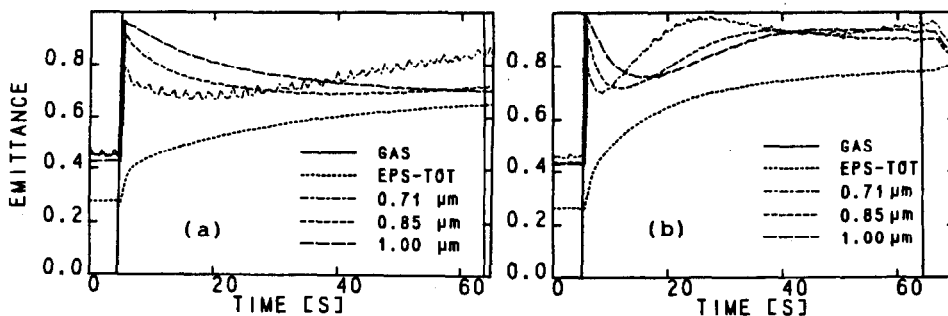

Fig. 2. Total emittance and spectral emittance at 0.71, 0.85 and 1.0  $\mu\text{m}$  versus time on stainless steel samples before and during exposure to oxidation by humid air at oxidation temperatures (a) = 980  $^{\circ}\text{C}$ , (b) = 1060  $^{\circ}\text{C}$

advantages are the large aperture and the fact that the temperature of the cavity is uniform under steady state as well as non steady state conditions. Details of the measurement device, accuracy, and calibration procedure are described in ref. 4 and 5.

### Results

Three characteristic examples of measured emittance-vs-time curves are plotted in Fig. 2 with stainless steel type 1.4016 as sample material. In the left part of the diagram (below 5 s) are shown the emittance values of the smooth surface, measured in inert atmosphere. At the perpendicular line the oxidation process in humid air (dew point  $\sim 25$   $^{\circ}\text{C}$ ) starts. The sample temperature during oxidation was 980  $^{\circ}\text{C}$  in Fig. 2a and 1060  $^{\circ}\text{C}$  in Fig. 2b.

These diagrams and the tabulated values respectively can be used in a manifold manner. From the wavelength dependency of the emittance the corrections needed in radiation thermometry can be reduced or valuable wavelengths combinations for ratio pyrometry can be selected. E.g. when the combinations 0.71/0.85, 0.71/1.0 and 0.85/1.0 are compared after an oxidizing time of 60 s the errors in ratio pyrometry are 80 K, 50 K, and 10 K at 980  $^{\circ}\text{C}$  and 30 K, 5 K and -25 K at 1060  $^{\circ}\text{C}$  if the emittance ratios are assumed to equal one.

The pronounced maxima and minima in the emittance-vs-time curves of Fig. 2 enable us additionally to calculate the oxide thickness. Unfortunately only less data on optical properties of oxi-

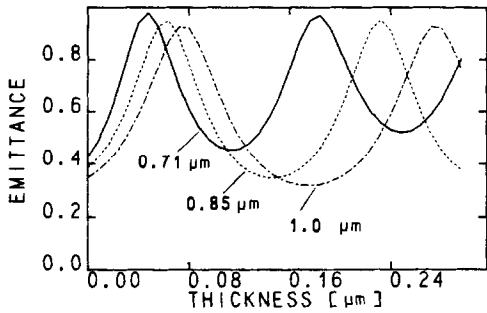

Fig. 3. Spectral emittance-vs-thickness of an  $\text{Fe}_2\text{O}_3$ -film on stainless steel substrate, calculated from the optical constants

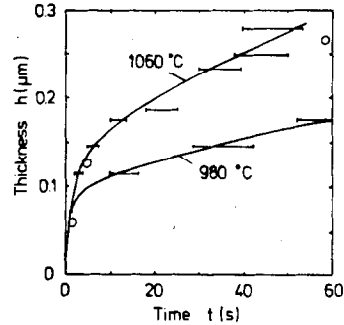

Fig. 4. Oxide growth rate, determined with the aid of emittance measurements as shown in Fig. 2

des are available from the literature. In ref. 6 values for  $\text{Fe}_2\text{O}_3$  are given and the optical constants of the steel substrate can be taken from ref. 7. These values and the equations described in ref. 8 lead to the spectral emittance as a function of the oxide thickness as shown in Fig. 3. If the optical properties and the optical conditions are comparable, the maxima and minima in Fig. 3 correspond with those of Fig. 2. The resulting thickness-vs-time curves are plotted in Fig. 4 for the oxidizing temperatures 980 °C and 1060 °C. The circles in Fig. 4 are values of oxide thicknesses measured on selected samples by Auger-electron-spectroscopy combined with a controlled sputtering. The good agreement demonstrates the suitability of the described emittance measurement technique to investigate oxide growth of interference layers.

#### REFERENCES

- 1 B. Wörner and G. Neuer, High Temp.-High Pressures 11 (1979) 383-391.
- 2 B. Wörner, in Temperature, Its Measurement and Control in Science and Industry 5, American Institute of Physics, New York, 1982, pp. 429-432.
- 3 G. Neuer and O. Brost, Inst. Phys. Conf. Series 26 (1975) 446-452.
- 4 B. Wörner and G. Neuer, High Temp.-High Pressures 15 (1983) 455-462.
- 5 B. Wörner and G. Neuer, Archiv für das Eisenhüttenwesen (to be published).
- 6 B. Karlsson and C.G. Ribbing, J. Appl. Phys. 53 (1982) 6340-46.
- 7 Landolt-Börnstein, Band II, Teil 3 Optische Konstanten, Springer Verlag, Berlin, Heidelberg, New York, 1962, p. 2-174
- 8 M. Ruiz-Urbieto, E. M. Sparrow, and E.R.G. Eckert, J. of the Optical Society of America 61 (1971) 351-359.