

FAST TEMPERATURE CHANGE DEVICE.

L. BELKBIR

Laboratory of solide/gaz systems reactivity. Department of chemistry.
Faculty of sciences- RABAT-MOROCCO-.

INTRODUCTION

In thermogravimetric -isothermal analysis we usually have a problem of temperature at the beginning of the reaction. The temperature conditioning, at time-zero, varies according to the heating system ; consequently the process of reactions is modified. To solve this we have realized a device for fast temperature conditioning (fig : 1).

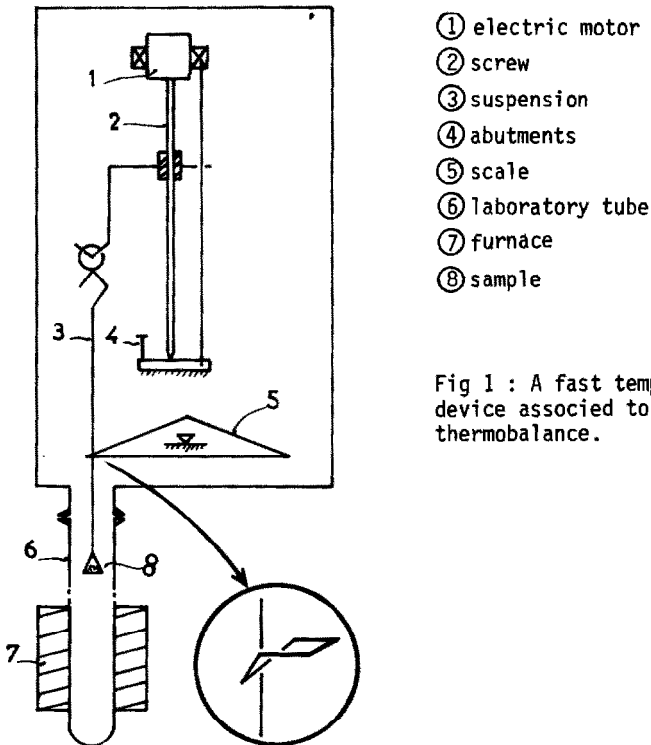

Fig 1 : A fast temperature change device associated to a type scale thermobalance.

This system allows the displacement of the sample in the laboratory tube of all types of thermobalances.

In the scale type, for example, this is realized by means of displacement of the suspension through a hole at the extremity of the scale. We can then displace the sample at will to have fast experimental conditions change at whatever degree (α_i) of the reaction conversion (fig : 2).

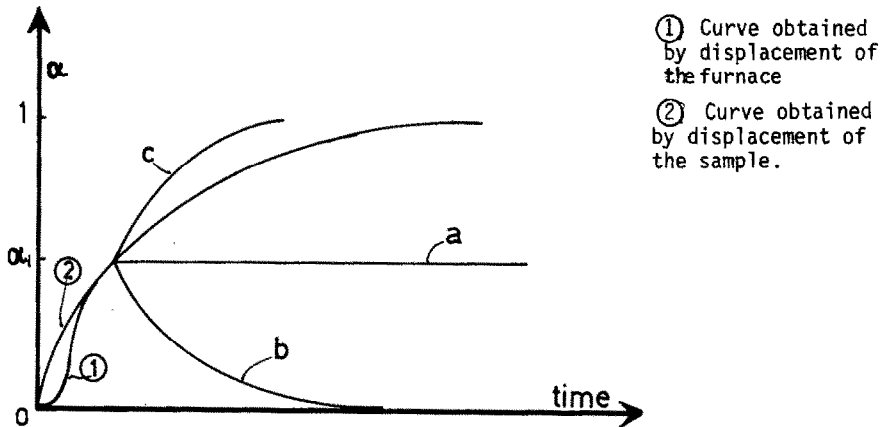

Fig 2 : A schematic evolution of reaction realized by displacement of the sample.

- a) the quenching at α_i
- b) the decomposition at α_i
- c) the formation at α_i

This system allows an exhaustive analysis of the sample in relation to the temperature with only one volume of gas in reversible systems solid/gas type. Consequently, this device saves time, energy, and reactives. In addition, since only one volume of gas is used in the whole analysis, the toxicity due to the use of dangerous gas is minimised.

This device has been the object of a request for a patent.