

## EARLY DEVELOPMENTS OF EGA BY MASS SPECTROMETRY

HORST G. LANGER

*Dow Chemical U.S.A., New England Laboratory, Wayland, MA (U.S.A.)*

(Received 14 January 1986)

### ABSTRACT

The first attempts to combine thermoanalytical methods with Mass Spectrometry were made in the early 1960s and arose from the need to identify materials evolved during Thermal Analysis. Throughout the following years, examples from the literature demonstrated the power of this combination for a large variety of problems from different fields of chemistry. Because of the broad range of applications, today there are a multitude of ways to couple these two analytical techniques.

### INTRODUCTION

Thermal Analysis has become a household word in analytical chemistry; and Evolved Gas Analysis is a term well understood and a method widely practiced today. This was by no means the case when this author was first introduced to these topics. The time was 1957, the place the Chemistry Department of Indiana University and the problem was identification of hydrothermally produced calcium phosphate samples and their changes on heating. Infrared Spectroscopy and X-ray Diffraction were the standard tools, but who had heard of the homemade piece of equipment in the Geology Department called Differential Thermal Analysis (DTA)? The title sounded intriguing and indeed the method allowed the detection of thermal processes at measurable temperatures. But interpretation of an indicated event in terms of a chemical reaction or a physical change was up to the ingenuity of the investigator or required additional analytical work.

A few years later this experience was used at the Eastern Research Laboratory of the Dow Chemical Company in the study of inorganic hydrates and organo-tin compounds. Synthesis of the latter materials is mostly carried out at elevated temperatures and, as the literature described, often “accompanied by decomposition”. In fact, an understanding developed that this decomposition, if properly controlled, could lead to the formation of desired products. Thus, DTA again proved to be a valuable tool and by now commercial instruments had become readily available. Yet, additional work was still required for identification of the reaction products,

especially if they happened to be gaseous and if they escaped during the reaction. Simultaneously but independently in the laboratory next door, a time-of-flight mass spectrometer had been installed and several inlet systems were being evaluated. The crucial work was published in 1963 [1] which opened the door to developments of a number of techniques, known today as Evolved Gas Analysis (EGA) by Mass Spectrometry (MS).

## EARLY INSTRUMENTATION

The first instrumental arrangement consisted of a time-of-flight mass spectrometer with a unique extra long drift tube developed by R.S. Gohlke together with the Bendix Corporation [2]. An advantage of this instrument was an open ion source construction, which allowed the introduction of a furnace and a needle-tipped probe equipped with a thermocouple at its end (Figs. 1 and 2). The sample, contained in a glass capillary tube, was heated by the furnace, close to the ion source. Temperature, up to about 500°C, was controlled by manual adjustment of a rheostat, measured by a thermocouple, and read in timed intervals from a voltmeter. Data were obtained as mass spectra, photographed from an oscilloscope screen or an oscillographic recorder with photosensitive paper. Alternatively, the intensity of one or several ions could be traced out on the visicorder. For any presentation or publication the intensity curves had to be redrawn.

Initially, the concept of EGA was tested with a number of known chemical reactions releasing simple gaseous molecules [3]. Examples are shown in Figs. 3 and 4. Two problems surfaced immediately. One was poor temperature control of the sample, in part due to the absence of convection

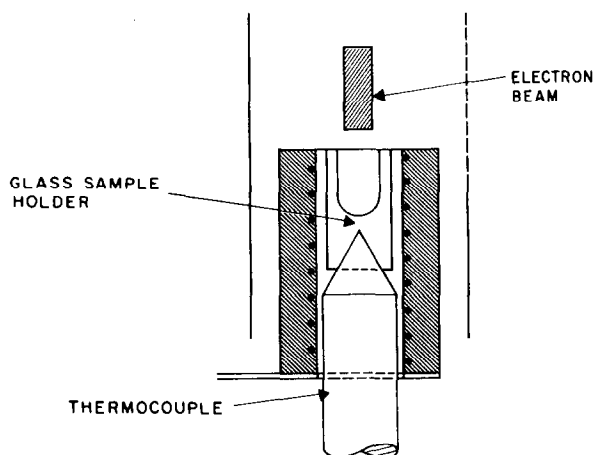

Fig. 1. First sample holder for mass spectrometer.

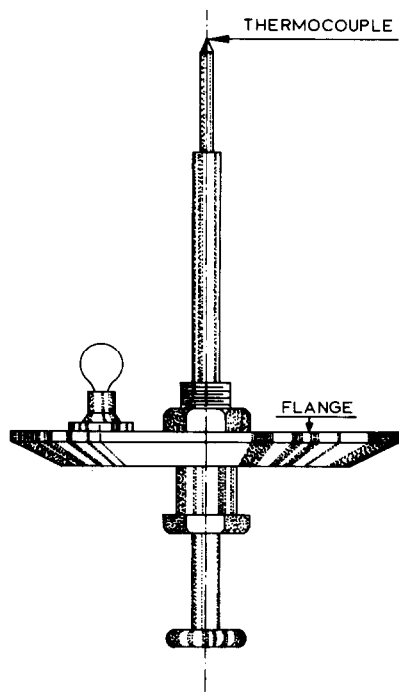

Fig. 2. Sample holder flange.

under the low operating pressure of the mass spectrometer and in part caused by varying thermal conductivities of sample holders or the samples themselves. Since they are inherent to vacuum conditions, these limitations still exist today. The other difficulty was the correlation of mass spectrometric data with those obtained under ambient conditions (such as DTA), especially for pressure-dependent reactions (Fig. 5). On the other hand, such comparisons often led to an understanding of these processes.

This method proved valuable not only for detection of unknown reaction

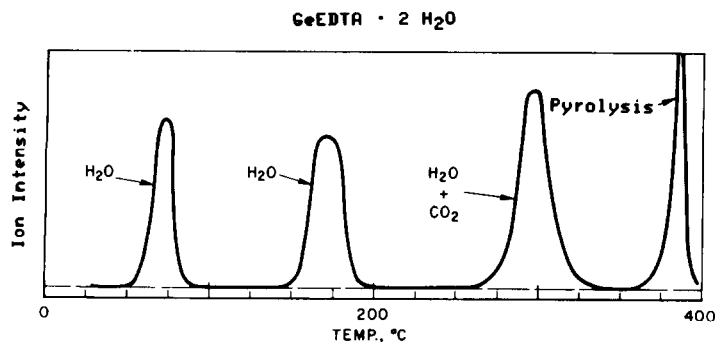

Fig. 3. Release of volatiles from a germanium chelate.

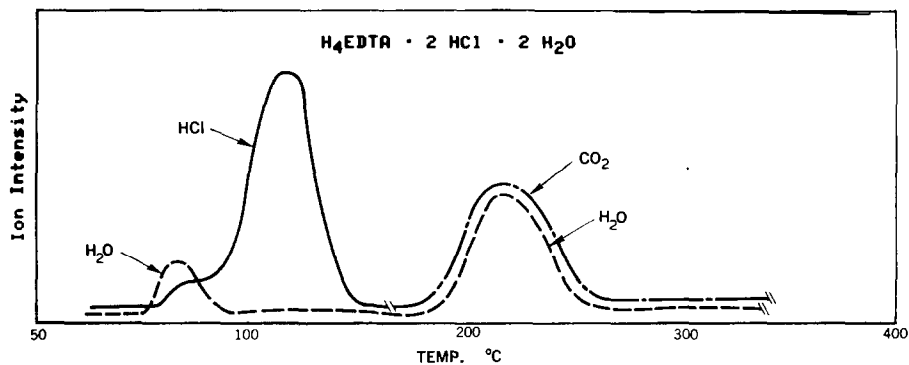

Fig. 4. Release of volatiles from a chelating agent.

products but also for investigations of fast and overlapping reactions. Semiquantitative information was readily gleaned from the intensity plots. Yet all these reactions occurred at about  $10^{-5}$  torr. Therefore the next task was an adaptation of the mass spectrometer to measure species evolved at ambient or intermediate pressures.

For this purpose a commercial DTA cell [4] was modified as shown in Fig. 6. The evolved gas or vapor, or part of it, entered a narrow-bore tube above the reacting sample and then the mass spectrometer through a reducing valve. The DTA cell was differentially pumped through the valve, so that the reactions could be carried out at pressures between ambient and  $10^{-3}$  torr. Although this method was rather crude in present-day terms and there were slight delays in response time for the mass spectrometer, the results were significant. One of the examples is shown in Fig. 7. For this particular piece of equipment any detected pressure-dependent reaction

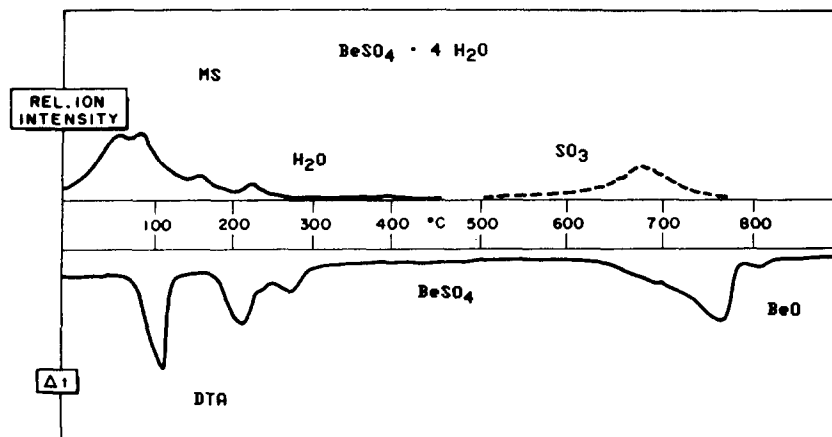

Fig. 5. Decomposition of  $\text{BeSO}_4 \cdot 4\text{H}_2\text{O}$  by DTA and MS.

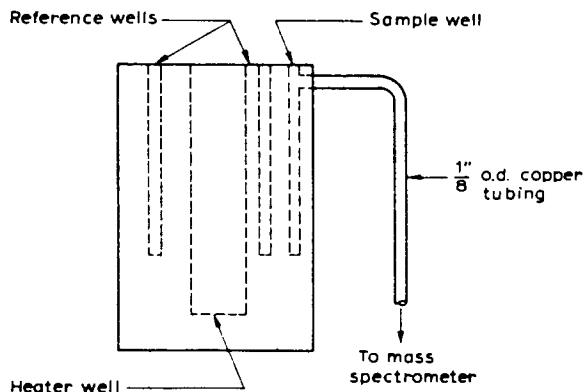

Fig. 6. Modified DTA cell for MS sampling.

could be further studied by varying the operational pressure of the DTA cell. From Fig. 7 the effect of vacuum on diffusion-controlled processes and on those governed by thermodynamics is apparent. There is also a slight lag between the DTA signal and the mass spectrometer output, which is a combination of chromatographic time delay and a dilution effect during sample transport.

The next phase consisted of both instrument and methodology development. All of the tedious manual operations had to be automated without serious sacrifices of information or reliability. In addition, the initial cost and the difficult operation of a high-powered mass spectrometer prohibited a general use. To that end a very small time-of-flight instrument was

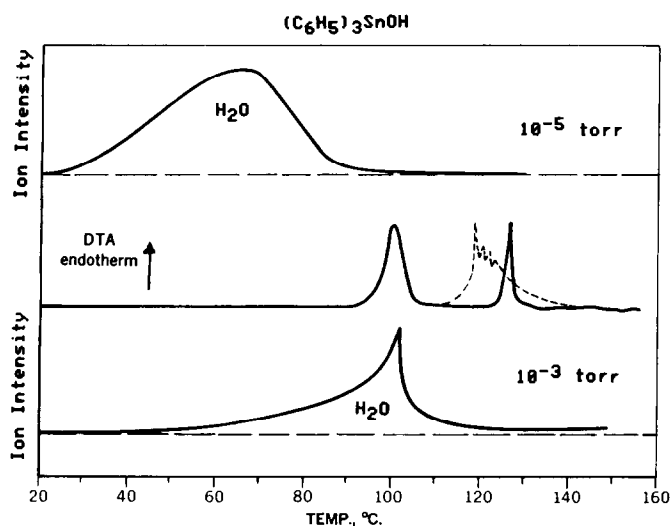

Fig. 7. Dehydration of triphenyltin hydroxide.

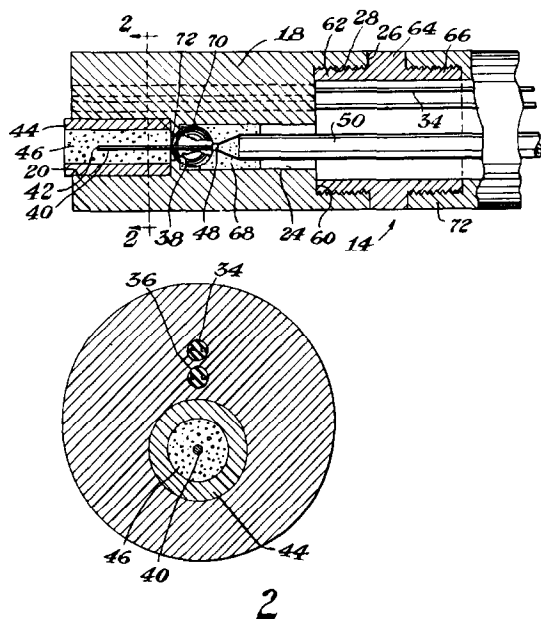

Fig. 8. DTA cell for mass spectrometers.

constructed, with a useful range of up to about 200 mass units [5]. Instead of direct recording of a few ion intensities, the complete mass spectra were scanned from an oscilloscope at rates of one to ten spectra per second and recorded on magnetic tape. Instead of the simple solids probe described above, a new internal DTA cell was constructed [6] together with a radiant furnace [7] as shown in Figs. 8 and 9. Use of a highly conductive silver block and radiant energy assured a better heat transfer. The cell was operated by a commercial DTA control unit (Du Pont 900 System and step-down trans-

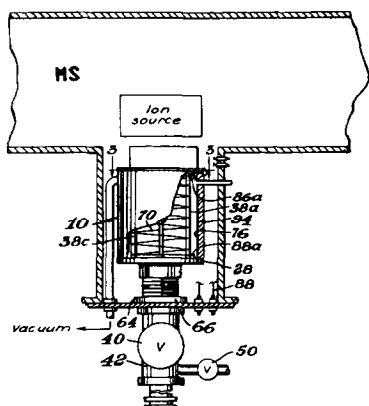

Fig. 9. Radiant furnace for mass spectrometers.

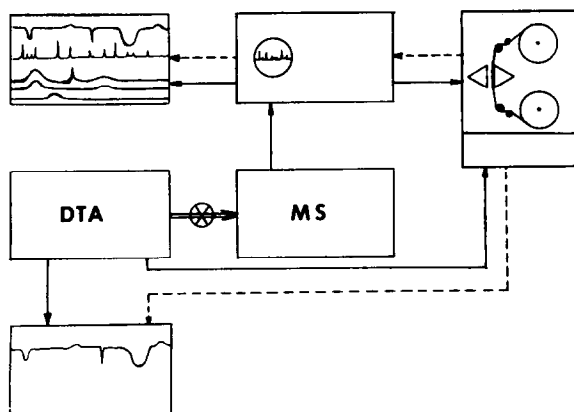

Fig. 10. Automated DTA/MS data acquisition system.

former). Temperatures of up to 500°C were obtained. From the recorded information any number of intensity plots could be drawn via a gate output from the oscilloscope. A schematic of this arrangement is shown in Fig. 10 [8]. Typical examples are shown in Figs. 11–12 for a study on the effect of fire retardants in various polymer systems [9].

One word about DTA/MS. In retrospect, a more logical combination would have been the mass spectrometric analysis from a method designed to evolve gases, such as Thermogravimetry (TG). The main reason for this lack was fortuitous, historical and economical. TGA equipment was either not readily available, too expensive, or needed a more elaborate inlet system to transport the evolving species from the thermobalance into the mass spectrometer.

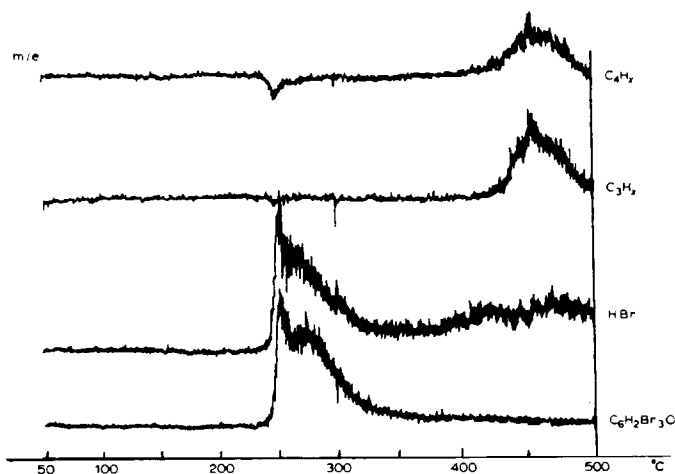

Fig. 11. Pyrolysis of fire retarded polyethylene.

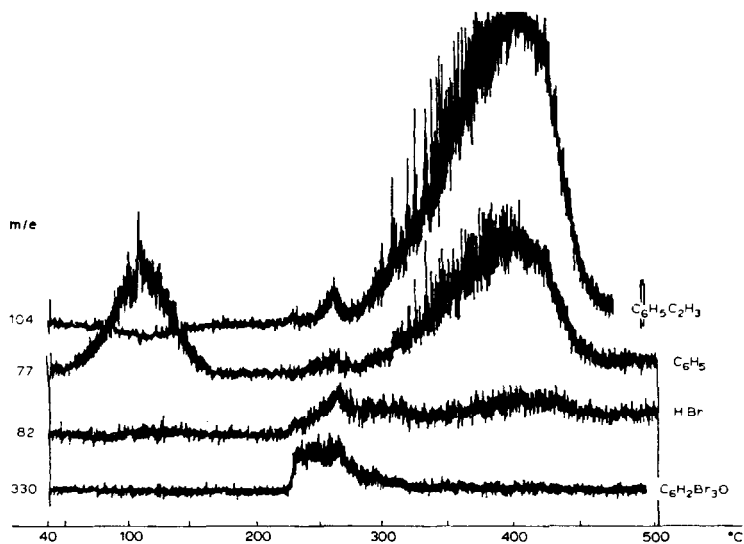

Fig. 12. Pyrolysis of fire retarded polystyrene.

At this point a historical reflection is in order: it appears that the growth of a new scientific field is stimulated by the formation of a communications framework such as a society, a journal or at least an annually rescheduled

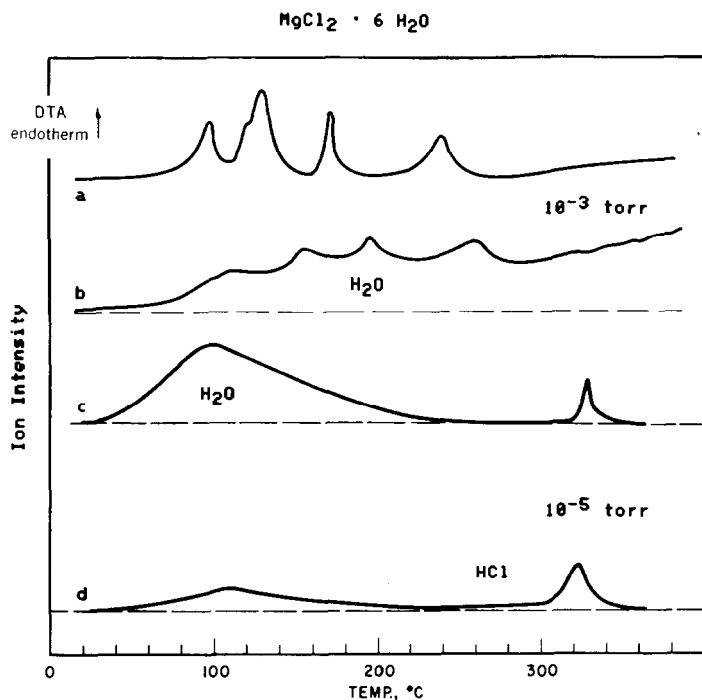

Fig. 13. Dehydration of  $MgCl_2 \cdot 6H_2O$ .



meeting. The development described above took place before societies such as NATAS and ICTA existed and before *Thermochemica Acta* had started publication. On the other hand, regular annual conferences on Mass Spectrometry had been held, and it was here, where the first symposium on "Thermal Analysis" was held [10]. The symposium covered combinations of mass spectrometry with differential thermal analysis, thermogravimetry and gas chromatography as well as very high temperature chemistry of oxides, halides and oxyhalides.

During the following years the methodology development split into two different paths. With mass spectrometrists the emphasis shifted towards advancing GC/MS combinations with little regard to temperature control of the original sample. On the other hand, thermal analysts dominated the applications of evolved gas analysis using the mass spectrometer as an overly sophisticated detector. Various approaches were reported in the literature, in symposia, review articles and book chapters [11–19]. Essentially all describing a singular, unique piece of equipment, designed and constructed by the authors for their own particular needs.

#### APPLICATIONS

As mentioned earlier, a number of dehydration reactions were studied successfully. Questions often raised were whether a particular material could be completely dehydrated and what temperatures were necessary to achieve it, or whether application of vacuum could save energy. For all ceramic processing this is an important economic consideration. For other reactions, high temperature hydrolysis was an undesirable feature. The dehydration of magnesium chloride hydrates for electrolytic magnesium production is such

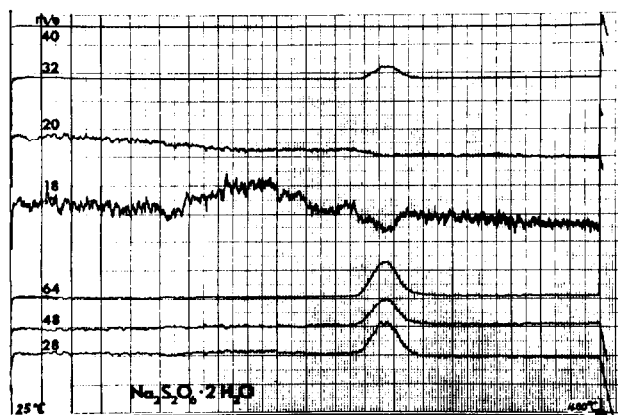

Fig. 14. Decomposition of  $\text{Na}_2\text{S}_2\text{O}_3 \cdot 2\text{H}_2\text{O}$ .

TABLE 1 [11]

Comparison of composition of sulfur vapor ( $S_n$ )

FE <sup>a</sup>		KC <sup>b</sup>		GI <sup>c</sup>		DIP <sup>d</sup>	
<i>n</i>	<i>I</i> <sup>e</sup>	<i>n</i>	<i>I</i>	<i>n</i>	<i>I</i>	<i>n</i>	<i>I</i>
8	100	8	100	2	100	2	100
2	70	2	95	1	8	1	51
4	48	4	64	6	7	4	40
5	29	5	41	4	2	8	36
3	15	6	39	8	2	3	25
6	15	3	24	5	2	5	17
1	11	1	10	3	1	6	13
7	<1	7	8	7	<1	7	2
Temp. (°C)	73		75	Sample:	250	50-700	
				Inlet:	120		

<sup>a</sup> FE: "free evaporation" of rhombic sulfur.<sup>b</sup> KC: Knudson-cell evaporation of rhombic sulfur.<sup>c</sup> GI: evaporation through gas inlet system of undefined sulfur.<sup>d</sup> DIP: evaporation by temperature programmed direct insertion probe from sulfur- and sulfide-containing sample.<sup>e</sup> *I*: normalized intensity.

an example (Fig. 13). Curves a and b show the stepwise dehydration of the hexahydrate at  $10^{-3}$  torr. However even at the still lower pressure of  $10^{-5}$  torr (Curves c and d), hydrolysis could not be avoided as indicated by the release of HCl near 100°C and the decomposition of a hydroxychloride at about 330°C.

In another case, the overlap of several chemical reactions could make or break an important class of commercial chemicals: fire retardants. As the traces in Figs. 11 and 12 show, only if the decomposition of the polymer (which produces the gaseous fuel) coincides with that of the additive (which produces the volatile bromine-containing species) can the flame propagation be retarded. In the case of the polyethylene sample, the fire retardant has already been nearly exhausted by the time the bulk of the flammable gas is produced. On the other hand, for the polystyrene example, the flame retardant is available for both the onset and the continuation of the pyrolysis.

Another class of compounds investigated more extensively are those containing sulfur. Table 1 [11] demonstrates how the composition of sulfur vapor varies for different experimental conditions. To a lesser extent, this is also true for the oxides of sulfur (Tables 2 and 3). For this reason, the interpretation of mass spectra from decomposition of such materials has often been difficult [20,21]. Figures 14 and 15 show the release of sulfur-containing species.

TABLE 2 [12]

Mass spectrum of fuming sulfuric acid (30% SO<sub>3</sub>)<sup>a</sup>

<i>m/e</i>	Ion	Rel. int. (%)
16	S <sup>2+</sup>	< 10 corr.
32	S <sup>+</sup>	56 corr.
34	S <sup>34+</sup>	< 5
48	SO <sup>+</sup>	100
50	S <sup>34</sup> O <sup>+</sup>	< 8
64	SO <sub>2</sub> <sup>+</sup>	100
66	S <sup>34</sup> O <sub>2</sub> <sup>+</sup>	< 8
80	SO <sub>3</sub> <sup>+</sup>	0
81	HSO <sub>3</sub> <sup>+</sup>	32
83	HS <sup>34</sup> O <sub>3</sub> <sup>+</sup>	< 5

<sup>a</sup> Sample temp.: 80–100°C; pressure: approx. 10<sup>-7</sup> torr.

TABLE 3 [12]

Mass spectrum of vapor from copper sulfate<sup>a</sup>

<i>m/e</i>	Ion	Rel. int. (%)
32	S <sup>+</sup>	29 corr.
48	SO <sup>+</sup>	68
50	S <sup>34</sup> O <sup>+</sup>	7
64	SO <sub>2</sub> <sup>+</sup>	100
66	S <sup>34</sup> O <sup>+</sup>	5
80	SO <sub>3</sub> <sup>+</sup>	14

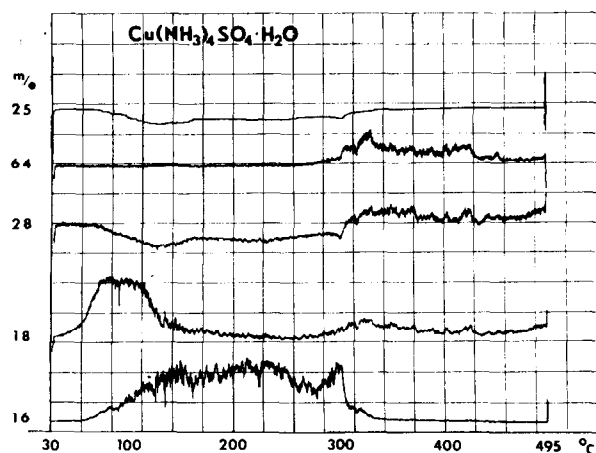
<sup>a</sup> Sample temp.: 650°C; pressure: approx. 10<sup>-7</sup> torr.Fig. 15. Decomposition of Cu(NH<sub>3</sub>)<sub>4</sub>SO<sub>4</sub>·H<sub>2</sub>O at 10<sup>-5</sup> torr.

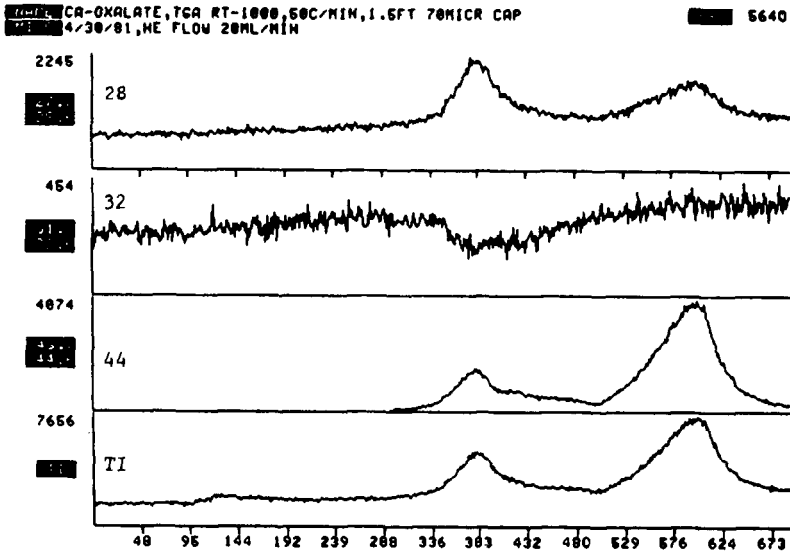
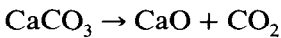
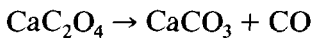
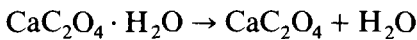

Fig. 16. Decomposition of calcium oxalate monohydrate by TG/MS.

Calcium oxalate has long been regarded as the classical standard for any thermoanalytical work. However the sequence of reactions [22]:



leading in the first step to anhydrous oxalate, followed by formation of carbonate with release of carbon monoxide and finally decomposition of the carbonate to the oxide with release of carbon dioxide, is by no means straightforward but depends on the operating conditions [23,24]. Most

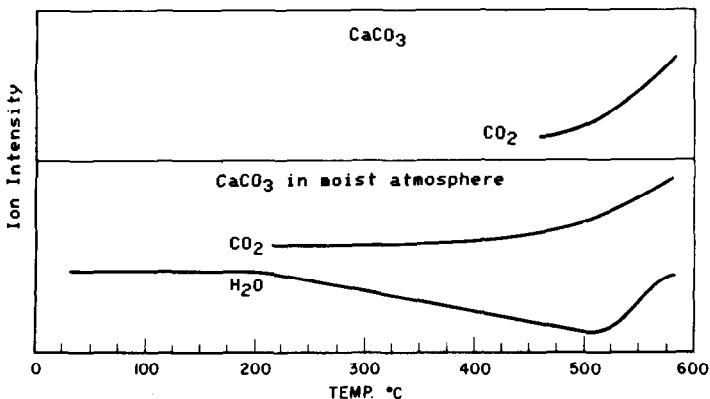

Fig. 17. Decomposition of calcium carbonate in dry and moist air.

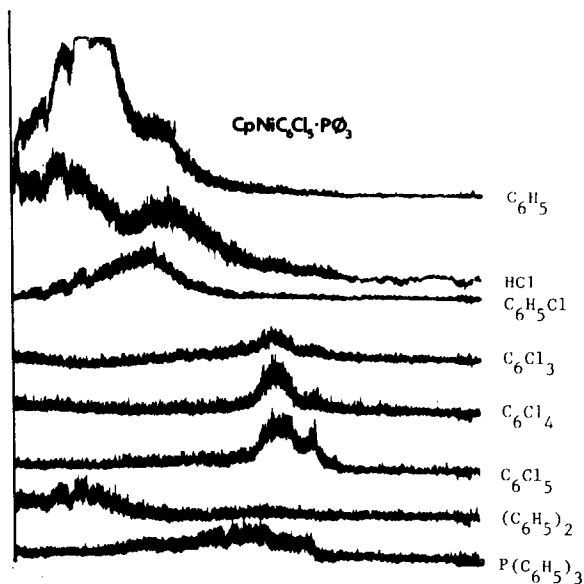

Fig. 18. Decomposition of an organo-nickel complex.

notable is the oxidative equilibrium with formation of carbon dioxide at the oxalate decomposition, which can easily be catalyzed by container materials, such as platinum. This explains the appearance of a peak for  $m/e = 44$  at scan # 383 (Fig. 16), while the peak at scan # 600 for  $m/e = 28$  is due to a carbon dioxide fragment.

Carbonate decomposition can also be influenced by the presence of water vapor as shown in Fig. 17 [11]. Here, as in the case of magnesium chloride discussed above, the reaction is changed into a high temperature hydrolysis step, followed by dehydration of the hydroxide.

The last example is chosen from organometallic chemistry. Figure 18 is a relatively simple demonstration of the very complex thermal reactions these compounds can undergo, with release of both organic and inorganic species and their fragments, as well as a number of volatile metal complexes [25].

## CONCLUSION

Within the framework of thermal analysis, mass spectrometry, as the examples show, is uniquely suited for the identification of thermally produced reaction products as well as for studies of thermally induced gas phase reactions themselves. In that sense these two important analytical methods truly complement each other, provided their operating parameters are clearly recognized for each experiment carried out. Because of the broad scope of operating conditions for each, an almost endless array of ways to

combine them does indeed exist and requires a choice of the one best suited for the task at hand.

## EPILOG

The time now is 1986. The field of Thermal Analysis has made enormous advances. In retrospect this could have happened only through a combination of efforts and events. The most important of which was without doubt the recognition by the scientific community that thermal analysis was an essential tool of modern research. With it came the development of methodology and instrumentation, which was greatly aided by the rapid progress in computer technology. Thermal Analysis by Mass Spectrometry is now available in many forms, in many degrees of sophistication, through combinations of many instruments and in many stages of automation. The latter, however, requires a caveat. With the apparent ease today to obtain a wealth of data, the need for such data acquisition is sometimes overlooked. Meaningless data are as useless as meaningless experiments. For instance, Fig. 19, as impressive as it looks, does not provide any more information than Fig. 16. In fact, the entire intensity curve for mass 32 in this representation is hidden behind that of mass 28. Thus the choice of a method and the selection of data become critical. Sometimes it may be necessary to conduct truly simultaneous experiments, while at others one may be better off to use consecutive analytical methods. Furthermore, computerization now has made

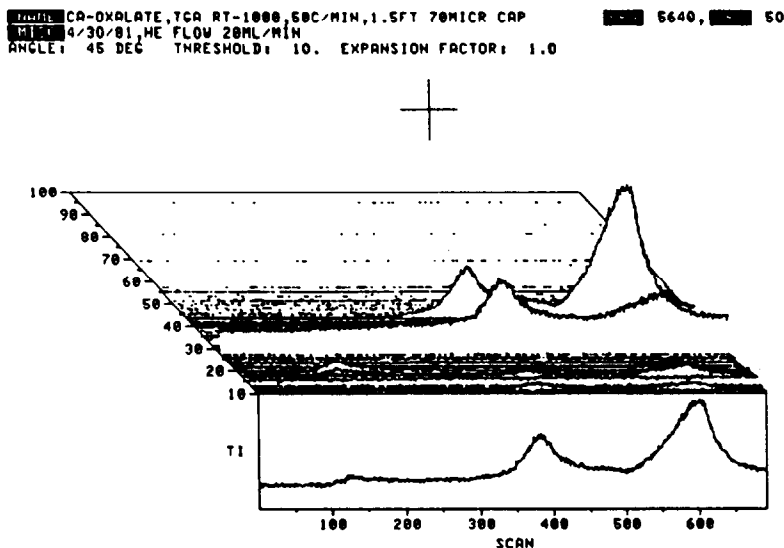

Fig. 19. Computer presentation of calcium oxalate decomposition.

most operations of analytical instruments opaque to the observer, so that equipment malfunctions are not always easily recognized, which may result in erroneous output being interpreted as real data. The solution is straightforward: to begin with, the experiment should be kept as simple as possible, to produce only the information necessary. Subsequently, a second, possibly different, analysis should be carried out to confirm the first result.

Instrumental problems still exist. Interfaces from ambient to mass spectrometer conditions still are not readily commercially available, however, some GC inlet systems can be used directly, or are easily adapted. A very simple and generally satisfactory pressure-reducing device is a 12 in. long uncoated capillary silica GC column of 70  $\mu\text{m}$  diameter. This device works particularly well for organic vapors. The so-called direct insertion probes still lack the temperature control available in thermoanalytical equipment. This may be the reason why pyroprobes have been developed as a form of isothermal analysis inside a mass spectrometer.

Ironically, instrumental development and computerization has made mass spectrometers such valuable and powerful equipment that they are not readily available to thermal analysts. The answer would be a commercial, low cost, low resolution "residual gas analyzer" type instrument equipped with a reliable temperature programmed and controlled direct insertion probe and a simple capillary inlet (ideally, but not necessarily, programmable to the sample temperature) for sampling from thermoanalytical devices, such as a thermobalance.

Yes, indeed, all this laborious experience during the early days of Thermal Analysis has been invaluable for an understanding of efficient use of modern techniques.

## REFERENCES

- 1 R.S. Gohlke, *Chem. Ind. (London)*, (1963) 946.
- 2 D.B. Harrington and R.S. Gohlke, *Pap. No. 23, ASTM Committee E-14 on Mass Spectrometry*, New Orleans, LA, 1962.
- 3 H.G. Langer and R.S. Gohlke, *Anal. Chem.*, 35 (1963) 1301.
- 4 H.G. Langer, R.S. Gohlke and D.H. Smith, *Anal. Chem.*, 37 (1965) 433.
- 5 H.G. Langer and F. Karle, presented at the 15th Ann. Conf. on Mass Spectrometry and Allied Topics, Denver, CO, 1967.
- 6 H.G. Langer, *USP 3623355*, 1971.
- 7 H.G. Langer and E.D. Ayers, *USP 3629889*, 1971.
- 8 H.G. Langer and T.P. Brady, in R.F. Schwenker, Jr. and P.D. Garn (Eds.), *Thermal Analysis*, Vol. 1, Academic Press, New York, 1969, p. 295.
- 9 H.G. Langer and T.P. Brady, *Thermochim. Acta*, 5 (1973) 391.
- 10 Papers presented as a Symposium on Thermal Analysis at the 17th Ann. Conf. on Mass Spectrometry and Allied Topics, Dallas, TX, 1969.
- 11 H.G. Langer and R.S. Gohlke, *Fortschr. Chem. Forsch.*, 6 (1966) 515.
- 12 H.G. Langer and R.S. Gohlke, *Mass spectrometric identification of gaseous products*

- from thermal analysis, in W. Lodding (Ed.), *Gas Effluent Analysis*, Marcel Dekker, New York, 1967.
- 13 J. Chiu, *Anal. Chem.*, 40 (1968) 1516.
  - 14 W.W. Wendlandt, *Thermal Methods of Analysis*, 2nd edn., Wiley, New York, 1974.
  - 15 H.L. Friedman, Thermal aging and oxidation with emphasis of polymers, in I.M. Kolthoff, P.J. Elving and F.H. Stross (Eds.), *Treatise on Analytical Chemistry*, Part III, Vol. 3, Sect. D-1, Wiley-Interscience, New York, 1976.
  - 16 P.K. Gallagher, *Thermochim Acta*, 26 (1978) 175.
  - 17 J. Chiu and A.J. Beattie, *Thermochim. Acta*, 40 (1980) 251.
  - 18 T. Szendrei and P.C. van Berge, *Thermochim. Acta*, 44 (1981) 11.
  - 19 H.G. Langer, Evolved gas analysis, in I.M. Kolthoff, P.J. Elving and C.B. Murphy (Eds.), *Treatise on Analytical Chemistry*, Part 1, Vol. 12, Sect. J, Wiley-Interscience, New York, 1983, Chap. 6, p. 229.
  - 20 W.W. Wendlandt and T.M. Southern, *Anal. Chim. Acta*, 32 (1965) 405.
  - 21 R.S. Gohlke and H.G. Langer, *Anal. Chim. Acta*, 36 (1966) 530.
  - 22 E.S. Freeman and B. Carroll, *J. Phys. Chem.*, 62 (1958) 394.
  - 23 H.G. Wiedemann, in R.F. Schwenker and P.D. Garn (Eds.), *Thermal Analysis*, Vol. 1, Academic Press, New York, 1969, p. 229.
  - 24 D. Price, D. Dollimore, N.S. Fatemi and R. Whitehead, *Thermochim. Acta*, 42 (1980) 323.
  - 25 H.G. Langer, T.P. Brady, M.D. Rausch and H.B. Gordon, presented at the 16th Ann. Conf. on Mass Spectrometry and Allied Topics, Pittsburg, PA, 1968.