



**NONRESIDENT
TRAINING
COURSE**



October 1998

Construction Electrician Intermediate

NAVEDTRA 14027

Although the words “he,” “him,” and “his” are used sparingly in this course to enhance communication, they are not intended to be gender driven or to affront or discriminate against anyone.

DISTRIBUTION STATEMENT A: Approved for public release; distribution is unlimited.

COMMANDING OFFICER
NETPDTC
6490 SAUFLEY FIELD RD
PENSACOLA, FL 32509-5237

ERRATA

13 Jun 2001

Specific Instructions and Errata for
Nonresident Training Course

CONSTRUCTION ELECTRICIAN INTERMEDIATE,
NAVEDTRA 14027

1. No attempt has been made to issue corrections for errors in typing, punctuation, etc., that do not affect your ability to answer the question or questions.
2. Make the following changes:
 - a. Page 5-12, figure 5-10, add the following sentence to the figure caption: "Lamp is lit when voltage is present."
 - b. Page 5-12, figure 5-11, delete the existing figure caption and replace the caption with "Second step in testing an outlet with a neon tester. Lamp is lit only when voltage is present."
 - c. Page 5-13, figure 5-12. Note these changes to the figure: The terminals in figure 5-12 should be the same as in figure 5-13 (power input on the bottom terminal and load on the top terminal). Consequently, the neon tester lead should be on the top terminal and the tester lamp should be OFF to indicate the condition set in the figure caption.
 - d. Page 5-14, figure 5-17, add the following sentence to the figure caption. "Lamp should glow only when test lead is in the right side outlet slot and voltage is present."
 - e. Page 5-15, under the title Fuse, change step 1 to read as follows:
"1. First determine if voltage is present at the supply side of the fuse by placing one of the neon tester leads on the top of one fuse and the other lead to ground. Test the other fuse in the same manner. Glowing lamp indicates that voltage is supplied to the fuse."
 - f. Page 5-15, under the title Fuse, change step 2 to read as follows:
"2. Determine if voltage is present at the load side of the fuse by placing one lead of the neon tester on the bottom side of the fuse and the other lead to ground. Test the other fuse in the same manner. If the tester lamp DOES NOT glow and voltage is present at the supply side of the fuse, the fuse is defective."
 - g. Page 5-16, delete figure 5-19 (all four views).
 - h. Page 5-22, delete figure 5-28 and delete the first five lines of text in the left column that apply to figure 5-28.
 - i. Delete topic on "Airfield Lighting" from page 6-28 through page 6-50. This section on airfield lighting is deleted because airfield lighting is no longer covered by occupational standards for Construction Electricians.

j. Delete chapter 8 on "Alarm Systems." This chapter is deleted because fire alarms are no longer covered by occupational standards for Construction Electricians.

3. Delete the following questions, and leave the corresponding spaces blank on the answer sheet:

Questions

5-11 through 5-27
5-64 through 5-75

PREFACE

By enrolling in this self-study course, you have demonstrated a desire to improve yourself and the Navy. Remember, however, this selfstudy course is only one part of the total Navy training program. Practical experience, schools, selected reading, and your desire to succeed are also necessary to successfully round out a fully meaningful training program.

THE COURSE: This self-study course is organized into subject matter areas, each containing learning objectives to help you determine what you should learn along with text and illustrations to help you understand the information. The subject matter reflects day-to-day requirements and experiences of personnel in the rating or skill area. It also reflects guidance provided by Enlisted Community Managers (ECMs) and other senior personnel, technical references, instructions, etc., and either the occupational or naval standards, which are listed in the *Manual of Navy Enlisted Manpower Personnel Classifications and Occupational Standards*, NAVPERS 18068.

THE QUESTIONS: The questions that appear in this course are designed to help you understand the material in the text.

VALUE: In completing this course, you will improve your military and professional knowledge. Importantly, it can also help you study for the Navy-wide advancement in rate examination. If you are studying and discover a reference in the text to another publication for further information, look it up.

*1998 Edition Prepared by
CECS Jose V. P. Ferriols*

Published by
NAVAL EDUCATION AND TRAINING
PROFESSIONAL DEVELOPMENT
AND TECHNOLOGY CENTER

**NAVSUP Logistics Tracking Number
0504-LP-026-7050**

Sailor's Creed

“I am a United States Sailor.

I will support and defend the Constitution of the United States of America and I will obey the orders of those appointed over me.

I represent the fighting spirit of the Navy and those who have gone before me to defend freedom and democracy around the world.

I proudly serve my country's Navy combat team with honor, courage and commitment.

I am committed to excellence and the fair treatment of all.”

CONTENTS

CHAPTER	PAGE
1. Construction Support	1-1
2. Drawings and Specifications.	2-1
3. Generators	3-1
4. Electrical Distribution	4-1
5. Interior Wiring	5-1
6. Fiber Optics and Lighting Systems.	6-1
7. Electrical Equipment	7-1
8. Alarm Systems	8-1
APPENDIX	
I. References Used to Develop the TRAMAN	AI-1
INDEX	INDEX-1

Nonresident Training Course Follows The Index

SUMMARY OF THE CONSTRUCTION ELECTRICIAN TRAINING SERIES

CONSTRUCTION ELECTRICIAN BASIC

Construction Electrician Basic, NAVEDTRA 11038, replaces *Construction Electrician 3* and should be studied by those seeking advancement to Construction Electrician Third Class. The major topics in the Basic TRAMAN are construction support activities, drawings and specifications, power generation and distribution, interior wiring, lighting and communication, and electrical appliances, test equipment, motors, and generators.

CONSTRUCTION ELECTRICIAN INTERMEDIATE

This TRAMAN, replaces *Construction Electrician 3&2* and should be studied by those seeking advancement to Construction Electrician Second Class. Topics in this book will be a continuation of information covered in the *Construction Electrician Basic* TRAMAN. The major topics in this TRAMAN are construction support, drawings and specifications, generators, electrical distribution, interior wiring, fiber optics and lighting systems, electrical equipment, and alarm systems.

CONSTRUCTION ELECTRICIAN ADVANCED

This TRAMAN, when published (refer to NAVEDTRA 12061 for availability), will replace *Construction Electrician 1* and should be studied by those seeking advancement to Construction Electrician First Class. Topics in this book will be a continuation of information covered in the *Construction Electrician Intermediate* TRAMAN.

SAFETY PRECAUTIONS

Safety is a paramount concern for all personnel. Many of the Naval Ship's Technical Manuals, manufacturer's technical manuals, and every Planned Maintenance System (PMS) maintenance requirement card (MRC) include safety precautions. Additionally, OPNAVINST 5100.19 (series), *Naval Occupational Safety and Health (NAVOSH) Program Manual for Forces Afloat*, and OPNAVINST 5100.23 (series), *NAVOSH Program Manual*, provide safety and occupational health information. The safety precautions are for your protection and to protect equipment.

During equipment operation and preventive or corrective maintenance, the procedures may call for personal protective equipment (PPE), such as goggles, gloves, safety shoes, hard hats, hearing protection, and respirators. When specified, your use of PPE is mandatory. You must select PPE appropriate for the job since the equipment is manufactured and approved for different levels of protection. If the procedure does not specify the PPE, and you aren't sure, ask your safety officer.

Most machinery, spaces, and tools requiring you to wear hearing protection are posted with hazardous noise signs or labels. Eye hazardous areas requiring you to wear goggles or safety glasses are also posted. In areas where corrosive chemicals are mixed or used, an emergency eyewash station must be installed.

All lubricating agents, oil, cleaning material, and chemicals used in maintenance and repair are hazardous materials. Examples of hazardous materials are gasoline, coal distillates, and asphalt. Gasoline contains a small amount of lead and other toxic compounds. Ingestion of gasoline can cause lead poisoning. Coal distillates, such as benzene or naphthalene in benzol, are suspected carcinogens. Avoid all skin contact and do not inhale the vapors and gases from these distillates. Asphalt contains components suspected of causing cancer. Anyone handling asphalt must be trained to handle it in a safe manner.

Hazardous materials require careful handling, storage, and disposal. PMS documentation provides hazard warnings or refers the maintenance man to the Hazardous Materials User's Guide. Material Safety Data Sheets (MSDS) also provide safety precautions for hazardous materials. All commands are required to have an MSDS for each hazardous material they have in their inventory. You must be familiar with the dangers associated with the hazardous materials you use in your work. Additional information is available from you command's *Hazardous Material Coordinator*. OPNAVINST 4110.2 (series), *Hazardous Material Control and Management*, contains detailed information on the hazardous material program.

Recent legislation and updated Navy directives implemented tighter constraints on environmental pollution and hazardous waste disposal. OPNAVINST 5090.1 (series), *Environmental and Natural Resources Program Manual*, provides detailed information. Your command must comply with federal, state, and local environmental regulations during any type of construction and demolition. Your supervisor will provide training on environmental compliance.

Cautions and warnings of potentially hazardous situations or conditions are highlighted, where needed, in each chapter of this TRAMAN. Remember to be safety conscious at all times.

INSTRUCTIONS FOR TAKING THE COURSE

ASSIGNMENTS

The text pages that you are to study are listed at the beginning of each assignment. Study these pages carefully before attempting to answer the questions. Pay close attention to tables and illustrations and read the learning objectives. The learning objectives state what you should be able to do after studying the material. Answering the questions correctly helps you accomplish the objectives.

SELECTING YOUR ANSWERS

Read each question carefully, then select the BEST answer. You may refer freely to the text. The answers must be the result of your own work and decisions. You are prohibited from referring to or copying the answers of others and from giving answers to anyone else taking the course.

SUBMITTING YOUR ASSIGNMENTS

To have your assignments graded, you must be enrolled in the course with the Nonresident Training Course Administration Branch at the Naval Education and Training Professional Development and Technology Center (NETPDTC). Following enrollment, there are two ways of having your assignments graded: (1) use the Internet to submit your assignments as you complete them, or (2) send all the assignments at one time by mail to NETPDTC.

Grading on the Internet: Advantages to Internet grading are:

- you may submit your answers as soon as you complete an assignment, and
- you get your results faster; usually by the next working day (approximately 24 hours).

In addition to receiving grade results for each assignment, you will receive course completion confirmation once you have completed all the

assignments. To submit your assignment answers via the Internet, go to:

<http://courses.cnet.navy.mil>

Grading by Mail: When you submit answer sheets by mail, send all of your assignments at one time. Do NOT submit individual answer sheets for grading. Mail all of your assignments in an envelope, which you either provide yourself or obtain from your nearest Educational Services Officer (ESO). Submit answer sheets to:

COMMANDING OFFICER
NETPDTC N331
6490 SAUFLEY FIELD ROAD
PENSACOLA FL 32559-5000

Answer Sheets: All courses include one “scannable” answer sheet for each assignment. These answer sheets are preprinted with your SSN, name, assignment number, and course number. Explanations for completing the answer sheets are on the answer sheet.

Do not use answer sheet reproductions: Use only the original answer sheets that we provide—reproductions will not work with our scanning equipment and cannot be processed.

Follow the instructions for marking your answers on the answer sheet. Be sure that blocks 1, 2, and 3 are filled in correctly. This information is necessary for your course to be properly processed and for you to receive credit for your work.

COMPLETION TIME

Courses must be completed within 12 months from the date of enrollment. This includes time required to resubmit failed assignments.

PASS/FAIL ASSIGNMENT PROCEDURES

If your overall course score is 3.2 or higher, you will pass the course and will not be required to resubmit assignments. Once your assignments have been graded you will receive course completion confirmation.

If you receive less than a 3.2 on any assignment and your overall course score is below 3.2, you will be given the opportunity to resubmit failed assignments. **You may resubmit failed assignments only once.** Internet students will receive notification when they have failed an assignment--they may then resubmit failed assignments on the web site. Internet students may view and print results for failed assignments from the web site. Students who submit by mail will receive a failing result letter and a new answer sheet for resubmission of each failed assignment.

COMPLETION CONFIRMATION

After successfully completing this course, you will receive a letter of completion.

ERRATA

Errata are used to correct minor errors or delete obsolete information in a course. Errata may also be used to provide instructions to the student. If a course has an errata, it will be included as the first page(s) after the front cover. Errata for all courses can be accessed and viewed/downloaded at:

<http://www.advancement.cnet.navy.mil>

STUDENT FEEDBACK QUESTIONS

We value your suggestions, questions, and criticisms on our courses. If you would like to communicate with us regarding this course, we encourage you, if possible, to use e-mail. If you write or fax, please use a copy of the Student Comment form that follows this page.

For subject matter questions:

E-mail: n314.products@cnet.navy.mil
Phone: Comm: (850) 452-1001, Ext. 1826
DSN: 922-1001, Ext. 1826
FAX: (850) 452-1370
(Do not fax answer sheets.)
Address: COMMANDING OFFICER
NETPDTC (CODE 314)
6490 SAUFLEY FIELD ROAD
PENSACOLA FL 32509-5237

For enrollment, shipping, grading, or completion letter questions

E-mail: fleetservices@cnet.navy.mil
Phone: Toll Free: 877-264-8583
Comm: (850) 452-1511/1181/1859
DSN: 922-1511/1181/1859
FAX: (850) 452-1370
(Do not fax answer sheets.)
Address: COMMANDING OFFICER
NETPDTC (CODE N331)
6490 SAUFLEY FIELD ROAD
PENSACOLA FL 32559-5000

NAVAL RESERVE RETIREMENT CREDIT

If you are a member of the Naval Reserve, you will receive retirement points if you are authorized to receive them under current directives governing retirement of Naval Reserve personnel. For Naval Reserve retirement, this course is evaluated at 8 points. (Refer to *Administrative Procedures for Naval Reservists on Inactive Duty*, BUPERSINST 1001.39, for more information about retirement points.)

COURSE OBJECTIVES

In completing this nonresident training course, you will demonstrate a knowledge of the subject matter by correctly answering questions on the following subjects: Construction Support, Drawings and Specifications, Generators, Electrical Distribution, Interior Wiring, Fiber Optics and Lighting, Electrical Equipment, and Alarm Systems.

Student Comments

Course Title: Construction Electrician Intermediate

NAVEDTRA: 14027 **Date:** _____

We need some information about you:

Rate/Rank and Name: _____ SSN: _____ Command/Unit _____

Street Address: _____ City: _____ State/FPO: _____ Zip _____

Your comments, suggestions, etc.:

<p>Privacy Act Statement: Under authority of Title 5, USC 301, information regarding your military status is requested in processing your comments and in preparing a reply. This information will not be divulged without written authorization to anyone other than those within DOD for official use in determining performance.</p>
--

NETPDTC 1550/41 (Rev 4-00)

CHAPTER 1

CONSTRUCTION SUPPORT

INTRODUCTION

As a second class petty officer your duties and responsibilities will increase in the area of construction support. This chapter will discuss some of these responsibilities, such as the Advanced Base Functional Components System, shoring and excavation safety, project planning, network analysis, timekeeping, quality control, and hazardous materials.

ADVANCED BASE FUNCTIONAL COMPONENTS (ABFC)

The Advanced Base Functional Components (ABFC) System consists of two general-purpose publications: *Table of Advanced Base Functional Components with Abridged Initial Outfitting Lists*, OPNAV-41P3, and *Facilities Planning Guide*, Volumes I and II, NAVFAC P-437.

The ABFC System was developed to provide support facilities to constantly changing tactical and strategic situations. A modular or building-block concept was developed. Components were needed that would incorporate men, materials, equipment, and facilities designed and developed to fulfill specific functions, no matter where the components were placed. The Navy ABFC System is based on the early experience in advanced base planning and shipment used in World War II with improvements brought about by experiences learned in Korea, Vietnam, and the Persian Gulf.

The Navy ABFC System is the quantitative expression and measurement of planning, procurement, assembly, and shipping of material and personnel that is needed to satisfy facility support requirements. The basic groupings of the ABFC System are (1) **component**, a complete unit; (2) **facility**, a portion of a complete component; and (3) **assembly**, a portion of a facility. These simple definitions and the interaction of these three units will be fully explained later in this chapter.

OPNAV 41P3

The *Table of Advanced Base Functional Components with Abridged Initial Outfitting Lists*

(*ABIOL*), OPNAV 41P3, is a detailed itemized line-item printout of the material in each ABFC. Each system command (SYSCOM)/bureau is responsible for maintaining a detailed list of that portion of the *ABIOL* of an ABFC for which it has been assigned contributory responsibility.

NAVFAC P-437

The *Facilities Planning Guide*, NAVFAC P-437, is the basic document that identifies the structures and supporting utilities of the ABFC System. It consists of two volumes.

Volume I contains reproducible engineering drawings organized in three parts—Part I, *Component Site Plans*, indexed by component designation; Part II, *Facility Drawings and Networks*, indexed by facility number; and Part III, *Assembly Drawings*, indexed by assembly numbers.

Volume II contains the detailed data display for each component, facility, and assembly in the ABFC System. It also has three parts. Part I quantifies and describes, by DoD category code, the facilities requirements for each component. Part II quantifies and describes, by assembly number, the assembly requirements for each facility. Part III quantifies line-item requirements, by national stock number (NSN), for each assembly.

Other information used for planning, such as the crew size, man-hours by skill, land area, and fuel necessary to make a component, facility, or assembly operational is contained in the guide.

The NAVFAC P-437 includes facilities and assemblies that are not directly related to components shown in the OPNAV P-41P3. These predesigned facilities and assemblies give the planner alternatives for satisfying contingency requirements when the callout of a complete component is not desired. For the purpose of compatibility with other DOD planning systems, the NAVFAC P-437 has been oriented to the standard DOD category codes for classifying real property of the Navy, as listed in *Department of the Navy Facility Codes*, NAVFAC P-72. The cardinal category codes are shown in table 1-1.

Table 1-1.—Codes and Categories for Real Property

CODES	CATEGORIES
100	Operations and Training
200	Maintenance and Production
300	Research, Development, and Evaluation
400	Supply
500	Hospital and Medical
600	Administrative
700	Housing and Community Support
800	Utilities and Ground Improvements
900	Real Estate

A facility required for an electrical power plant will be found in the 800 series, Utilities and Ground Improvements. The assemblies contained within each of these facilities consist of a grouping of line items at the national stock number level that, when assembled, will perform a specific function in support of the facility. These assemblies are functionally grouped in such a way that the assembly relates to the Seabee skill required to install it. These groupings are shown in table 1-2.

Table 1-2.—Assemblies Functionally Grouped to Seabee Skills

DESCRIPTION	NUMBER START	SEQUENCE STOP
Builder (BU) Oriented	10,000	19,999
Utilitiesman (UT) Oriented	20,000	29,999
Construction Electrician (CE) Oriented	30,000	39,999
Steelworker (SW) Oriented	40,000	49,999
Equipment Operator (EO) Oriented	50,000	54,999
Waterfront Equipment	55,000	57,999
Underwater Construction and Diving Equipment	58,000	59,999
Operational Supplies	60,000	62,499
NBC Warfare	65,000	67,499
Personnel-Related Supplies	67,500	69,999
Unassigned at Present	70,000	79,999
Shop Equipment including Maintenance Tools	80,000	80,999
Unique ABFC Tool Kits	81,000	81,999
NCF TOA Construction Tools and Kits (Power Tools)	82,000	82,499
NCF TOA Construction Tools and Kits (Electric)	82,500	82,999
NCF TOA Construction Tools and Kits (Miscellaneous)	83,000	83,999
NCF TOA Construction Tools and Kits (Rigging)	84,000	84,999
Shop Equipment (ABFC Unique)	85,000	87,499

USING THE P-437

When you are using the ABFC System, remember that it is possible to tailor it to serve your specific needs. Understand your exact requirements and mission. Choose components, facilities, or assemblies that fit or can be tailored to meet your desired goals. Verify stock numbers and descriptions by using appropriate stock lists. Verification is done automatically when components, facilities, or assemblies are ordered.

A sample from volume II of NAVFAC P-437 shows the structure and type of information provided. Figure 1-1 shows the P-25 component, Naval Mobile Construction Battalion. The component contains a listing of facilities by category code.

One such facility is the electric power plant diesel, 2-200 kW without tank, facility, 811 10R. Figure 1-2 shows this **facility**. Note that within the facility the necessary assemblies are identified.

Figure 1-3 shows an assembly from within facility 811 10R. The listing for assembly 32602, titled "PANELBOARD ASSY 1200A WEATHER-

COMPONENT P25

SEP 15 88

NAVAL MOBILE CONSTRUCTION BATTALION

PROVIDES PERSONNEL, ADMINISTRATION, SUBSISTANCE, EQUIPMENT, AND MINIMAL HOUSING REQUIRED FOR THE MOBILIZATION OF THE MOBILE CONSTRUCTION BATTALION.

SITE PLAN 6027643

MAJOR REV 06 11 85

FACILITY	DESCRIPTION	FACILITY CAPACITY	QTY	COMPONENT CAPACITY	WEIGHT SHORT TON	CUBE MEAS TON	DOLLAR VALUE	CONST EFFORT MAN-HOURS
123 1QT	POL STOR-DSPNSG FACIL 20000 GAL	1 DL	2	2 DL	3.8	9.0	51,515	470
143 45AD	ARMORY SMALL (TRICON)	100 SF	2	200 SF	0	0	0	0
143 45AE	ARMORY CONTAINERIZED-STANDARD 20	160 SF	2	320 SF	0	0	0	0
214 20N	A CD AUTO /CONST EQUIP MAINT SHOP	4000 SF	2	8000 SF	7.2	16.0	54,146	210
219 10J	B C AND D COMPANY SHOPS MINIMAL	5024 SF	1	5024 SF	4.2	10.1	30,143	85
219 10P	CENTRAL TOOL ROOM 16x32 TENT	512 SF	4	2040 SF	2.0	6.8	18,539	32
441 10BD	STORAGE /SUPPLY /SPARE PRT 16x32 TENT	512 SF	5	2560 SF	2.0	7.0	11,858	30
530 10RD	MEDICAL-DENTAL /FIRST AID	1024 SF	1	1024 SF	1.3	4.4	8,184	40
610 10V	ADMINISTRATION OFFICE TENT	512 SF	6	3027 SF	3.0	9.6	15,448	48
722 10RD	GALLEY MESS FLD ROOM F /RAPID DEPL	800 MN	1	800 MN	8.3	25.6	85,791	285
723 20JA	HEAD 4-HOLE BURN OUT W/LATRINE	336 SF	17	5712 SF	27.2	45.9	17,570	0
723 61C	SHOWER BATH UNIT PORTABLE 9 HEAD	1 EA	4	4 EA	4.0	22.8	47,386	116
725 10AD	AIR DET TENT CAMP FACILITY	4608 SF	1	4608 SF	10.7	29.9	50,571	334
725 10J	TROOP HOUSING EMERGENCY 16x32 TENT	512 SF	53	27136 SF	26.5	84.8	136,448	424
730 40H	LAUNDRY SKID-MOUNTED	280 SF	1	280 SF	.4	1.7	21,217	8
811 10R	ELEC PWR PLANT DSL 2-200KW W/O TANK	400 KW	1	400 KW	.7	1.3	22,737	5
812 30DP	DIST CTR PORT 480-208 / 120V 30KVA		10		7.0	12.0	129,628	30
812 30PE	ELEC DISTR LINE 1000FT #6AWG	250 LF	2	500 LF	.2	6	1,486	22
812 30PF	ELEC DISTR LINE 1000FT #1 EXPED	250 LF	2	500 LF	.2	4	2,401	40
812 30PG	ELEC DISTR LINE 1000FT 250MCM EXPED	250 LF	10	2500 LF	7.0	9.0	31,017	670
812 30PK	DISTR CTR PORT 208 / 120V 30A 3PH		4		.4	1.2	9,053	8
812 30PL	DISTR CTR PORT 480-208 / 120V 15KVA		4		2.0	4.8	56,922	8
841 30Z	ELEC DISTR SPLC ENCL LARGE		2		.6	3.4	4,260	56
841 10M	WATER TREATMENT FACILITY 1500 GPH	30 KG	2	60 KG	9.0	15.2	101,187	38
872 40E	WATER STORAGE PORTABLE	30000 GA	2	60000 GA	6.0	10.6	48,473	166
872 10R	SECURITY ANCHORING FOR TENTS		10		.0	1.0	1,672	0
872 10Y	SECURITY FENCE PARRIER (2000 FT)	2000 LF	3	6000 LF	9.3	8.1	6,720	216
872 10Z	SECURITY FENCE PARRIER (2000 FT)	2000 LF	5	10000 LF	17.5	40.5	21,352	1,200
20D	BUNKER COMMAND POST	1 EA	3	3 EA	31.2	33.6	19,035	2,679
TOTAL NORTH (TEMPERATURE)					191.7	415.3	1,004,769	7,200
TOTAL TROPICAL (BASIS)					181.9	395.0	958,266	7,044

COMPONENT P25

CONST STD	LAPSED DAYS	LAND ACRES	POWER CONNECTED	KVA DEMAND	WATER GPD	SEWER GPD	FUEL GAL / 30 DAYS		
							HEATING DSL	MOGAS	PWR GEN DSL
INIT	6	53.0	27G	178	19,000	15,800	37,884	698	0
SKILLS MAN-HOURS	EA	BU	UT	CE	SW	ED	CM	NS	
	145	1,229	351	633	604	546	0	3,728	

CEIF0101

Figure 1-1.—Mobilization component (P-25) for a mobile construction battalion.

PROOF," indicates by line items the national stock numbers required to make the assembly operable. Assembly listings indicate the installed or collateral equipment provided. Certain installed or collateral equipment supplied by other SYSCOMs or bureaus are not furnished with the facilities or assemblies listed in the NAVFAC P-437. They must be ordered separately.

COMPONENT P-25

A breakdown of the component P-25, as shown in figure 1-1, is as follows: a brief header describing the mission and capabilities of the component. The site plan pertaining to each component is depicted by a NAVFAC drawing number. However, drawings in volume 1, part 1, are indexed by component designation, not drawing numbers. The word *NONE* appears for components that have no site plans. The

facilities required to make the component operative are listed in numerical sequence by DOD category code. The alpha suffix for each facility designator indicates differences between sizes, types, or layouts of facilities for the same functional purposes. Facility capacity is expressed in terms of the units of measure used in the NAVFAC P-72. The component capacity is a multiplication of the facility capacity and the quantity. Weight and cube are measured in normal units for export packing. Weight and construction effort are computed using The Seabee Planner's and Estimator's Handbook, NAVFAC P-405. Average construction conditions are assumed and computations are based on normal Seabee skill levels.

You compute the total of the weight, cube, and dollar value columns by adding all facilities or assemblies required in both tropical and northern

FACILITY 811 10R		PLANNING FACTOR (0.4-1.5)KW/MN		SEP 15 88					
ELECTRIC PWR PLANT DSL 2-200KW GEN W/CESE W/O TANK									
PROVIDES UP TO 400KW OF POWER AT 416Y/240 VOLTS OR 208Y/120 VOLTS 3-PHASE									
NAVFAC DRAWING NUMBER NONE				MAJOR REV. 06 14 88					
ASSEMBLY	DESCRIPTION	ZONE	QTY	WEIGHT POUNDS	CUBIC FEET	DOLLAR VALUE	CONST EFFORTS MANHOURS		
32054	SUPPORT EQUIP F/200KW GEN ECC512801		2	48.6	1.3	145.08	0		
512801	GENERATOR 200KW		2	210.0	0	988.80	0		
32602	PANELBOARD ASSY 1200A WEATHERPROOF		1	1,157.7	48.1	21,533.17	4		
32604	PARALLELING CABLE F/GENERATORS		1	4.0	4.0	69.72	1		
TOTAL NORTH (TEMPERATURE)		SHORT TON	MEAS TON						
		7	13	1,420.3	53.4	22,736.77	5		
TOTAL TROPICAL (BASIC)		7	13	1,420.3	53.4	22,736.77	5		
FACILITY 811 10R				PRIMARY UNIT OF MEASURE	400 KW	SECONDARY UNIT OF MEASURE	0		
CONST STD	LAPSED DAYS	LAND ACRES	POWER KVA CONNECTED	DEMAND VOLTS	PHASE	WATER TOT. GPD	WATER PEAK GPD	SEWER GPD	RECOV. CODE
INIT	2	00	0	0	0	0	0	0	A
FUEL (GAL./30 DAYS)		POWER KVA		WATER TOT. GPD		WATER PEAK GPD		SEWER GPD	
HEATING	PWR GEN	DEMAND		GPD		GPD		GPD	
DSL	MOGAS	DSL	EA	BU	UT	CE	SW	EO	CM
0	0	0	0	0	0	4	0	1	0
FUEL (GAL./30 DAYS)		POWER KVA		WATER TOT. GPD		WATER PEAK GPD		SEWER GPD	
HEATING	PWR GEN	DEMAND		GPD		GPD		GPD	
DSL	MOGAS	DSL	EA	BU	UT	CE	SW	EO	CM
0	0	0	0	0	0	4	0	1	0
CEIF0102									

Figure 1-2.—Typical listing of a facility, facility 811 10R.

ASSEMBLY 32602		ZONE		JUN 15 90					
PANELBOARD WEATHERPROOF 480 VOLTS 3-POLE 3-WIRE		1200 AMPERE		32602					
NAVFAC DRAWING NUMBER 6002625									
COG	STOCK NUMBER	DESCRIPTION	UI	QTY	WEIGHT POUNDS	CUBIC FEET	DOLLAR VALUE		
9G	5975-00-878-3791	ROD GROUND 3-3FT SECTIONS, 5/8N DIA. STEEL COPPER	EA	1	7.00	0840	15.42		
	1	CLAD, W/ DRIVING STUD, GROUND WIRE CLAMP AND TERMINAL							
		LUG AND 6FT NO 6 AWG BARE STRANDED COPPER WIRE	EA	1	47	0100	43		
9N	5999-00-257-7025	CLAMP GND 3/4 ROD 2-8 SOL	EA	1	500.00	42.0000	7,800.00		
2C	6110-00-213-8078	PANELBOARD, POWER DISTRIBUTION, PORTABLE, WEATHER- PROOF 400 KILOWATT INPUT-480 OR 208 V., 3-PHASE, 4-POLE, 5-WIRE 60 HZ, BUS CAPACITY-1200 AMPS 4-3 POLE INPUT AND 8-3 POLE OUTPUT CIRCUIT BREAKERS. APPENDIX E OF PD APPLIES	FT	15	1.20	0225	2.25		
9Z	6145-00-129-9320	WIRE COP SOL 6 AWG SOFT BARE	FT	600	648.00	6.0000	1,650.00		
9Z	6145-01-212-0272	WIRE ELECTRICAL #4/0 AWG EXPED							
ASSEMBLY 32602					TOTAL	1,157.73	48,136.5	9,468.62	
FUEL (GAL./30 DAYS)		POWER KVA		WATER TOT. GPD		WATER PEAK GPD		SEWER GPD	
HEATING	PWR GEN	DEMAND		GPD		GPD		GPD	
DSL	MOGAS	DSL	EA	BU	UT	CE	SW	EO	CH
0	0	0	0	0	0	3	0	1	0
FUEL (GAL./30 DAYS)		POWER KVA		WATER TOT. GPD		WATER PEAK GPD		SEWER GPD	
HEATING	PWR GEN	DEMAND		GPD		GPD		GPD	
DSL	MOGAS	DSL	EA	BU	UT	CE	SW	EO	CH
0	0	0	0	0	0	3	0	1	0
NOTE -- CREW SIZE: 1 CE, 1 EO									
CEIF0103									

Figure 1-3.—Typical listing of an assembly.

climates plus the unique requirements for either tropical or northern areas.

Summary data located below the component facility listings lists the following:

1. Construction standards (const std) are grouped into two classifications: initial and temporary.

a. INITIAL (INIT)—Duration of requirement less than 6 months.

b. TEMPORARY (TEMP)—Duration of requirement from 6 to 60 months.

2. Days of construction duration (lapsed days) are based on job requirements, optimum construction crew size, and full-material availability.

3. Often the land requirements, in acres, based on the assumed plot plan, will not be followed exactly because of terrain or existing buildings. The idealized plot plan was developed to design supporting utility systems. The material contained in the utility facilities has been increased to allow for variation in terrain.

4. The connected electrical load in kVA has been computed based on knowledge of *ABIOL* or Table of Allowance (TOA) contents. A load diversity factor has been applied to compute the kVA demand. Water and sewer demand are based on *ABIOL* or TOA contents and the utility systems designed to this criteria.

5. Compute 30-day requirements for installed engine-driven or fuel-fired equipment only. No allowance for automotive, construction, weight handling, and other jobsite support equipment fuel is included. Fuel is not provided when facilities or assemblies are shipped. NAVSUP provides fuel as a contribution when whole components are shipped.

6. The skill requirements are designated by Seabee (OF-13) ratings and are expressed in man-hours as computed for each facility.

FACILITY 811 10R

Figure 1-2 shows atypical facility entry in part 2 of volume I—electric power plant diesel 2-200 kW generators, without tank, facility 811 10R. Adjacent to the facility number, the heading shows the JCS planning factor applied. The header also describes the basic capability of the facility. The NAVFAC drawing number is shown for reference purposes. All drawings in volume I, part 2, are indexed by facility number.

The assemblies required to make the facility functionally operational are listed in assembly-number sequence. These numbers were derived from the prime trade involved in the construction. The 30,000 series indicates Construction Electricians; the 50,000, Equipment Operators.

Following a brief description of the assembly is the zone code. For facilities or assemblies that are designed for use in both northern and tropical zones, the zone column is usually left blank. However, assemblies required for Arctic operation are designated code “N.” The quantity given is a multiplier, indicating the number of assemblies to be ordered.

Weight and cubic feet are measured in normal terms for export packing. Weight, cube, and dollar value reflect totals for each line. Construction estimates are computed in the same manner as are components.

Summarized data is the same as that used for components with the following exceptions. In addition to primary facility capacity, secondary capacity, as

described in NAVFAC P-72, is included. This is used, for example, in the 700 series of facilities where the primary capacity is expressed in men, and the secondary, in square feet.

The recoverability code is a broad indication of the relocatability or recoverability. The code "A" indicates total recoverability, and "D" indicates a disposable facility. Details are found in table 1-3, Recoverability Codes.

ASSEMBLY 32602

Figure 1-3 shows a typical entry for an assembly. This assembly provides the necessary material for the installation of a 200-kilowatt generator. Header information is the same as that for a facility. Assembly line-item requirements are displayed by cognizance symbol and national stock number. The unit of issue, weight, cube, and dollar value are extracted from supply files once the requirement data is entered. This data changes often, but frequent changes will not be made in the *Facilities Planning Guide* for stock numbers with minor price-level changes.

ORDERING

Components, facilities, or assemblies can be ordered. Components are usually ordered only under a mobilization situation and requested through the CNO. Facilities and assemblies can be ordered without CNO approval if reimbursement is provided. Requests for release are forwarded to NCBC, Port Hueneme. Attention is directed to the *Facilities Projects Manual*, OPNAVINST 11010.20 (Series), regarding project approvals for peacetime use and to *Procurement, Lease, and Use of Relocatable Buildings*, OPNAVINST 11010.33 (Series), (DODINST 4165.56), regarding the relocatable building program.

INDEX OF FACILITIES

Suppose there is a requirement for an electrical distribution system underground. To determine what is available in the ABFC System to satisfy the requirement, look in volume 2, part 2, *Index of Facilities*, under the 800 series (Utilities and Ground Improvements), as shown in figure 1-4. If an approximate 11,000-foot system is needed, facility 812 30AB can be used; see figure 1-5.

Table 1-3.—Recoverability Codes

CODE	DEFINITION
A. Relocatable:	Designed for specific purpose of being readily erected, disassembled, stored, and reused. includes tentage.
B. Pseudo-Relocatable:	Not specifically designed to be dismantled and relocated, but could be, with considerable effort and loss of parts. Rigid-frame building included.
C. Nonrecoverable:	A structure not designed to provide relocatability features or one where the cost of recovery of the shelter exceeds 50% of the initial procurement cost. Bolted tanks and steel bridges included.
D. Disposable:	Those temporary structures having low acquisition and erection costs which are not designed for relocation and reuse and may be left on site or destroyed, such as SEAHUNTS.

EXCAVATIONS AND SHORING

Working in, working around, or directing a crew in a trenching or excavation job can be dangerous. The following paragraphs will give you some of the accepted engineering requirements and practices. Think safety, not only for your workers but for the other persons that may encounter your work area.

EXCAVATIONS

Preplanning before starting any excavation will save time and avoid costly mistakes. Give attention to personal safety equipment, underground utility installations, personnel/vehicular traffic interruptions, security, and public safety. Make sure your crew is aware of the safe working area around a specific piece of excavating equipment. Set up daily inspections of excavations for possible cave-ins or slides. Moving ground must be guarded by a shoring system, sloping of the ground, or some other equivalent means. Excavated or other materials must not be stored closer than 2 feet from the edge.

When crews are working in trenches 4 feet or more in depth, access into or exits out of excavations should be by ramps, ladders, stairways, or hoists. Crew

members should not jump into trenches or use bracing as a stairway.

Banks more than 5 feet high must be shored or laid back to a stable slope, or some other equivalent means of protection must be provided where crew members may be exposed to moving ground or cave-ins. Refer to figure 1-6 as a guide in sloping of banks.

Sides of trenches in unstable or soft material, 5 feet in depth, are required to be shored, sheeted, braced, sloped, or otherwise supported by sufficient strength to protect the crew members working within them.

Sides of trenches in hard or compact soil, including embankments, must be shored or otherwise supported when the trench is more than 5 feet in depth and 8 feet or more in length.

SHORING

The determination of the angle of repose and design of the supporting system must be based on careful evaluation of many features: depth or cut; possible variation in water content of the material while the excavation is open; anticipated changes in materials from exposure to air, sun, water, or freezing; loading imposed by structures, equipment, overlying

INDEX OF FACILITIES
ALPHABETIC

JUN 15 90

FACILITY	DESCRIPTION	CAPACITY		DRAWING	PAGE
		PRIMARY	SECONDARY		
811 10CN	ELEC PWR PLANT DSL 1-100KW W/PLWTNK	100 KW		6027582	
811 10AA	ELEC PWR PLANT DSL 1-15KW W/PLWTNK	15 KW		6139176	
811 10AE	ELEC PWR PLANT DSL 1-30KW W/PLWTNK	30 KW		6139175	
811 10AJ	ELEC PWR PLANT DSL 1-60KW W/PLWTNK	60 KW		6139174	
811 10TY	ELEC PWR PLANT DSL 2-100KW W/CESE	200 KW		NONE	
811 10AP	ELEC PWR PLANT DSL 2-100KW W/PLWTNK	200 KW		6139173	
811 10AB	ELEC PWR PLANT DSL 2-15KW W/PLWTNK	30 KW		6139176	
811 10R	ELEC PWR PLANT DSL 2-200KW W/O TANK	400 KW		NONE	
811 10AU	ELEC PWR PLANT DSL 2-200KW W/PLWTNK	400 KW		6139179	
811 10AE	ELEC PWR PLANT DSL 2-30KW W/PLWTNK	60 KW		6139175	
811 10AK	ELEC PWR PLANT DSL 2-60KW W/PLWTNK	120 KW		6139174	
811 10AR	ELEC PWR PLANT DSL 3-100KW W/PLWTNK	300 KW		6139173	
811 10CR	ELEC PWR PLANT DSL 3-100KW W/PLWTNK	300 KW		6027582	
811 10AC	ELEC PWR PLANT DSL 3-15KW W/PLWTNK	45 KW		6139176	
811 10AV	ELEC PWR PLANT DSL 3-200KW W/PLWTNK	600 KW		6139179	
811 10AG	ELEC PWR PLANT DSL 3-30KW W/PLWTNK	90 KW		6139175	
811 10AL	ELEC PWR PLANT DSL 3-60KW W/PLWTNK	180 KW		6139174	
811 10AW	ELEC PWR PLANT DSL 4-200KW W/PLWTNK	800 KW		6139179	
811 10BC	ELECTRIC POWER PLANT DIESEL 1-10KW	10 KW		NONE	
811 10CA	ELECTRIC POWER PLANT DIESEL 1-15KW	15 KW		6027585	
811 10CJ	ELECTRIC POWER PLANT DIESEL 1-60KW	60 KW		6027583	
811 10BD	ELECTRIC POWER PLANT DIESEL 2-10KW	20 KW		NONE	
811 10CU	ELECTRIC POWER PLANT DIESEL 2-200KW	400 KW		6027581	
811 10CF	ELECTRIC POWER PLANT DIESEL 2-30KW	60 KW		6027584	
811 10BB	ELECTRIC POWER PLANT DIESEL 2-5KW	10 KW		NONE	
811 10CK	ELECTRIC POWER PLANT DIESEL 2-60KW	120 KW		6027583	
811 10CC	ELECTRIC POWER PLANT DIESEL 3-15KW	45 KW		6027586	
811 10CY	ELECTRIC POWER PLANT DIESEL 3-200KW	600 KW		6027581	
811 10CG	ELECTRIC POWER PLANT DIESEL 3-30KW	90 KW		6027584	
811 10CL	ELECTRIC POWER PLANT DIESEL 3-60KW	180 KW		6027583	
811 10CW	ELECTRIC POWER PLANT DIESEL 4-200KW	800 KW		6027581	
811 10CM	ELECTRIC POWER PLANT DIESEL 4-60KW	240 KW		6027583	
811 10P	ELECTRIC POWER PLANT DIESEL 5-200KW	1000 KW	2x50 SF	6139179	
811 10TA	ELECTRIC POWER PLANT GED 5KW	5 KW		NONE	
811 45A	ELECTRIC PWR PLANT 2-750KW DIESEL	1500 KW		NONE	
812 30AB	ELECTRICAL DISTRIBUTION LINE-UGND	11000 LF		NONE	
812 30AD	ELECTRICAL DISTRIBUTION LINE-UGND	4200 LF		NONE	
812 30U	ELECTRICAL DISTRIBUTION LINES	2500 LF		NONE	
812 30CY	ELECTRICAL DISTRIBUTION LINES EXPD	2000 LF		NONE	
812 30CZ	ELECTRICAL DISTRIBUTION LINES EXPD	4000 LF		NONE	
812 30AE	ELECTRICAL DISTRIBUTION LINES-UGND	3500 LF		NONE	
812 30AF	ELECTRICAL DISTRIBUTION LINES-UGND	5000 LF		NONE	
812 30AT	ELECTRICAL DISTRIBUTION LINES-UGND	1075 LF		NONE	
812 30AX	ELECTRICAL DISTRIBUTION LINES-UGND	125 LF		NONE	
812 30BF	ELECTRICAL DISTRIBUTION LINES-UGND	250 LF		NONE	
812 30BG	ELECTRICAL DISTRIBUTION LINES-UGND	500 LF		NONE	
812 30BH	ELECTRICAL DISTRIBUTION LINES-UGND	5000 LF		NONE	
812 30BK	ELECTRICAL DISTRIBUTION LINES-UGND	4000 LF		NONE	
812 30BM	ELECTRICAL DISTRIBUTION LINES-UGND	2500 LF		NONE	
812 30BS	ELECTRICAL DISTRIBUTION LINES-UGND	7500 LF		NONE	
812 30CY	ELECTRICAL DISTRIBUTION LINES-UGND	1000 LF		NONE	
812 30E	ELECTRICAL DISTRIBUTION LINES-UGND	2000 LF		NONE	
812 30J	ELECTRICAL DISTRIBUTION LINES-UGND	875 LF		NONE	
812 30K	ELECTRICAL DISTRIBUTION LINES-UGND	750 LF		NONE	
812 30M	ELECTRICAL DISTRIBUTION LINES-UGND	2700 LF		NONE	
812 30P	ELECTRICAL DISTRIBUTION LINES-UGND	4000 LF		NONE	
812 30H	ELECTRICAL DISTRIBUTION LINES-UGND	750 LF		NONE	

CEIFO 004

Figure 1-4.—Alphabetical index of facilities.

material, or stored material; and vibration from equipment, blasting, traffic, or other sources..

Materials used for sheeting and sheetpiling, bracing, shoring, and underpinning have to be in good serviceable condition. Timbers must be sound and free from large or loose knots and must be designed and installed to be effective to the bottom of the excavation.

Cross braces or trench jacks must be placed in true horizontal position, be spaced vertically, and be secured to prevent sliding, falling, or kickouts. Minimum requirements for trenching timbers are shown in figure 1-7.

PROJECT PLANNING

Throughout the life of a project, information that reflects the complete history and requirements for that project is being accumulated and updated. The project package is the collection of all information required to plan, schedule, monitor, and execute a project. During the construction phase of a project, inspection reports, field change reports, and numerous items of project correspondence are added to the project package to complete the project history file. This file is continually updated until the project is completed. The most critical part of this project package is the project planning package.

FACILITY 812 30AB		PLANNING FACTOR NA		SEP 15 88							
ELECTRICAL DISTRIBUTION LINES -- UNDERGROUND 11000 FT											
NAVFAC DRAWING NUMBER NONE			MAJOR REV 04 14 78								
ASSEMBLY	DESCRIPTION	ZONE	QTY	WEIGHT POUNDS	CUBIC FEET	DOLLAR VALUE	CONST EFFORT MANHOURS				
32200	ELEC CONDUCTOR BURIAL 10AWG 1000FT		3	796.8	16.6	459.00	99				
32203	ELEC CONDUCTOR BURIAL 1AWG 1500FT		3	1948.4	27.3	1161.63	144				
32205	ELEC CONDUCTOR BURIAL 250MCM 1500FT		3	4758.0	77.2	6872.58	267				
32227	SPLICE BOX FIBERGLASS W/COVER		2	278.1	33.1	1064.92	14				
		SHORT TON	MEAS TON								
TOTAL NORTH (TEMPERATE)		3.9	3.9	7,781.3	154.2	9,558.13	524				
TOTAL TROPICAL (BASIC)		3.9	3.9	7,781.3	154.2	9,558.13	524				
FACILITY 812 30AB		PRIMARY UNIT OF MEASURE 11000 LF		SECONDARY UNIT OF MEASURE		0					
CONST STD	LAPSED DAYS	LAND ACRES	POWER CONNECTED	KVA DEMAND	VOLTS PHASE	WATER TOT GPD	WATER PEAK GPM	SEWER GPD	RECOV CODE		
TEMP	0	00	0	0	0 0	0	0	0	D		
FUEL (GAL/30 DAYS)		PWR GEN		SKILLS		MANHOURS					
HEATING	DSL	MOGAS	DSL	EA	BU	UT	CE	SW	EO	CM	NS
0	0	0	0	0	0	0	311	0	84	0	129

CEIF0105

Figure 1-5.—Assembly description of facility 812 30 AB, electrical distribution lines underground, 11,000 feet,

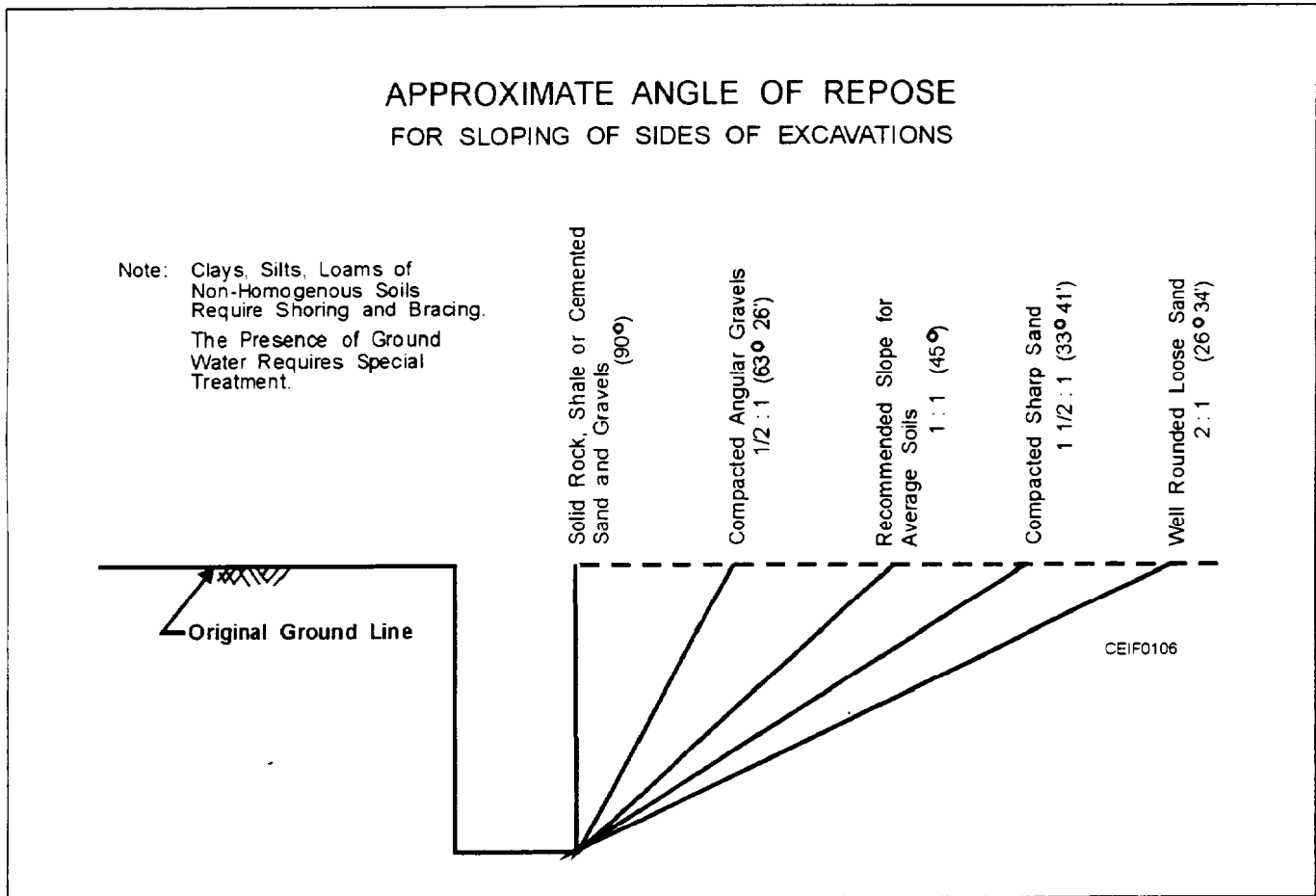

Figure 1-6.—Approximate angle of repose.

TRENCH SHORING--MINIMUM REQUIREMENTS

Depth of trench	Kind or condition of earth	Size and spacing of members										
		Uprights		Stringers		Cross braces ¹				Maximum spacing		
		Minimum dimension	Maximum spacing	Minimum dimension	Maximum spacing	Width of trench				Vertical	Horizontal	
Feet	Inches	Feet	Inches	Feet	Inches	Inches	Inches	Inches	Inches	Feet	Feet	
5 to 10	Hard, compact	3 x 4 or 2 x 6	6			2 x 6	4 x 4	4 x 6	6 x 6	6 x 8	4	6
	Likely to crack	3 x 4 or 2 x 5	3	4 x 6	4	2 x 6	4 x 4	4 x 6	6 x 6	6 x 8	4	6
	Soft, sandy or filled	3 x 4 or 2 x 6	Close sheathing	4 x 6	4	4 x 4	4 x 6	6 x 6	6 x 8	8 x 8	4	6
	Hydrostatic pressure	3 x 4 or 2 x 6	Close sheathing	3 x 8	4	4 x 4	4 x 6	6 x 6	6 x 8	8 x 8	4	6
10 to 15	Hard	3 x 4 or 2 x 6	4	4 x 6	4	4 x 4	4 x 6	6 x 6	6 x 8	8 x 8	4	6
	Likely to crack	3 x 4 or 2 x 6	2	4 x 6	4	4 x 4	4 x 6	6 x 6	6 x 8	8 x 8		6
	Soft, sandy or filled	3 x 4 or 2 x 6	Close sheathing	4 x 6	4	4 x 6	6 x 6	6 x 8	8 x 8	8 x 10	4	6
	Hydrostatic pressure	3 x 4 or 2 x 6	Close sheathing	8 x 10	4	4 x 6	6 x 6	6 x 8	8 x 8	8 x 10	4	6
15 to 20	All kinds or conditions	3 x 6	Close sheathing	4 x 12	4	4 x 12	6 x 8	8 x 8	8 x 10	10 x 10	4	6
Over 20	All kinds or conditions	3 x 6	Close sheathing	8 x 8	4	4 x 12	8 x 8	8 x 10	10 x 10	10 x 10	4	6

¹Trench jacks may be used in lieu of, or in combination with, cross braces. Shoring is not required in solid rock, hard shale, or hard slag. Where desirable, steel sheet piling and bracing of equal strength may be substituted for wood.

CEIF0107

Figure 1-7.—Trench shoring—minimum requirements.

PROJECT PLANNING PACKAGE

The entire history of a Naval Construction Force (NCF) project is documented in the standard five-section project package. A list of the contents of the project package (Seabee Project Package) is shown in Table 1-4. A flowchart showing the sequence of planning steps is shown in figure 1-8. It is quite evident from looking at the contents of the project planning package and at figure 1-8 that planning a project from the beginning to the end is an involved process. As a second class petty officer, you will be expected to

prepare this type of project pack-age, to a certain extent. This manual covers just a few aspects of the project package folder. For more detailed information, you will need to study the *Seabee Crewleader's Handbook*, *Operations Officer's Handbook*, and *Seabee Planner's and Estimator's Handbook*, NAVFAC P-405 (Series).

The basic principle of the project package is to divide a project into smaller, controllable units and to set up a project history file. A project is usually received from the regiment level where it is divided into master activities. The next step is to further

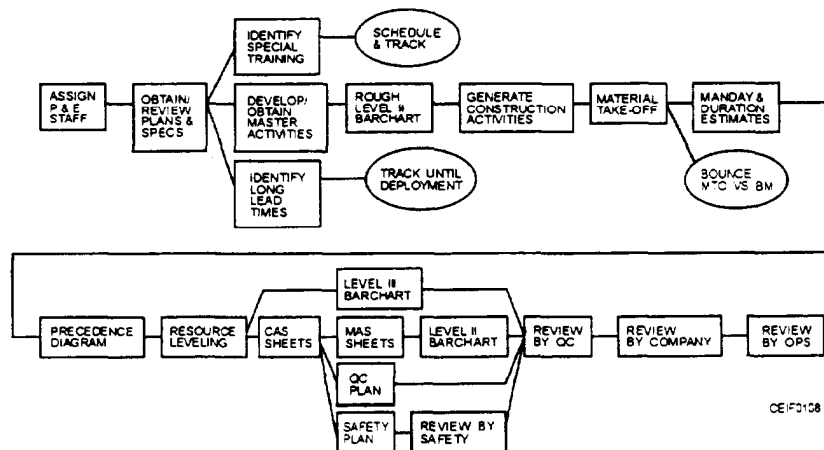

CEIF0108

Figure 1-8.—Project planning flowchart.

Table 1-4.—Seabee Project Package

SEABEE PROJECT PACKAGE

(*Required on All Projects)

(**Requirement may be waived in a contingency: operation)

SECTION #1 GENERAL INFORMATION AND CORRESPONDENCE

- 1A *Tasking Letter Correspondence
*Outgoing Messages and Correspondence
*Incoming Messages and Correspondence
- 1B Project Scope Sheet
Project Organization
Project Planning Milestones
Project Package Sign-off Sheet
Deployment Calendar
Preconstruction Conference Summary
Predeployment Site Visit Summary
Joint Turnover Memorandum
Pre-BOD Inspection Request

SECTION #2 ACTIVITIES AND NETWORK

- 2A *Level II Barchart
*Two Week Schedules
*Master Activity Listing
*Master Activity Summary Sheets
**Level III Precedence Diagram
- 2B Level III Barchart
Construction Activity Summary Sheets (Recommended including filled out 1250-1 s.)
Construction Activity Summary Sheets on Completed Activities
Two Week Labor Summaries
SITREP Feeders
Other Computer Printouts/Reports

SECTION #3 RESOURCES

- 3A *30/60/90-Day Material List
*30/60/90-Day Material List Letter

*Bill of Materials
*Tool Requirement Summary
*Equipment Requirement Summary
- 3B List of Long Lead Items
Material Take Off Worksheets
Bill of Materials/Material Take Off Comparison Worksheets
Material Transfer Requests
Add On/Reorder Justification Forms
Add On/Reorder BMs
Borrow Log

Table 1-4.—Seabee Project Package—Continued

SECTION #4 PLANS

- 4A *Quality Control Plan Cover Sheet
- *Quality Control Plan
- *Safety Plan Cover Sheet
- *General Safety Plan
- *Safety Plan
- *Environmental Plan

- 4B Daily Quality Control Inspection Reports
- Field Adjustment Request (FAR) Submittal Log
- FARs
- Request For Information (RFI) Submittal Log
- RFIs
- Design Change Directive (DCD)
- Concrete Placement Clearance Forms
- Pre-placement Photos for Concrete Placements
- Asphalt Pavement Clearance Forms
- Utility Interruption Request
- Excavation Request
- Road Closure Request
- Engineering Service Request
- Minerals Products Request
- Other QC Forms
- Daily Safety Inspection Reports
- Emergency Phone Numbers
- Navy Employee Report of Unsafe or Unhealthful Working Conditions
- Required Safety Equipment
- Daily Safety Lecture Log
- Accident/Near Mishap/Mishap Reports
- Highlighted 29 CFR 1926
- Hazardous Materials Inventory Sheet
- Other Safety Forms

SECTION #5 DRAWINGS/SPECIFICATIONS

- 5A *Project Plans
- **Highlighted Specifications

- 5B Site Layout
- Shop Drawings
- Detailed Slab Layout Drawings
- Forming Plans
- Rebar Bending Schedule
- Other Sketches/Drawings
- Technical Data

Table 1-5.—Information for a Precedence Activity (Typical Activity Block)

ACTIVITY NUMBER		ACTIVITY DURATION (DUR)	
EARLY START (ES)	ACTIVITY DESCRIPTION		EARLY FINISH (EF)
	ACTIVITY RESOURCES		
LATE START (LS)	TOTAL FLOAT (TF)	FREE FLOAT (FF)	LATE FINISH (LF)

break down the project into construction activities. This is normally done at the battalion level. From the construction activities, you will develop a logic network that will link the activities together into a

sequence of events from the beginning to the end and will show the dependencies between the activities. Table 1-5 shows an activity block that represents a single construction activity.. This is the building block on which the whole project will be planned and controlled. The connection of these blocks and their interdependence on each other makes up a network diagram. The sum of these network diagrams is called a network analysis.

NETWORK ANALYSIS

A network analysis is a method of planning and controlling projects by recording their interdependence in diagram form. This enables each fundamental problem involved to be undertaken separately. The network diagram form is drawn in such a way that each job is represented by an activity on the diagram, as shown in figure 1-9. This network diagram is based on the installation of the generators shown in figure 1-10.

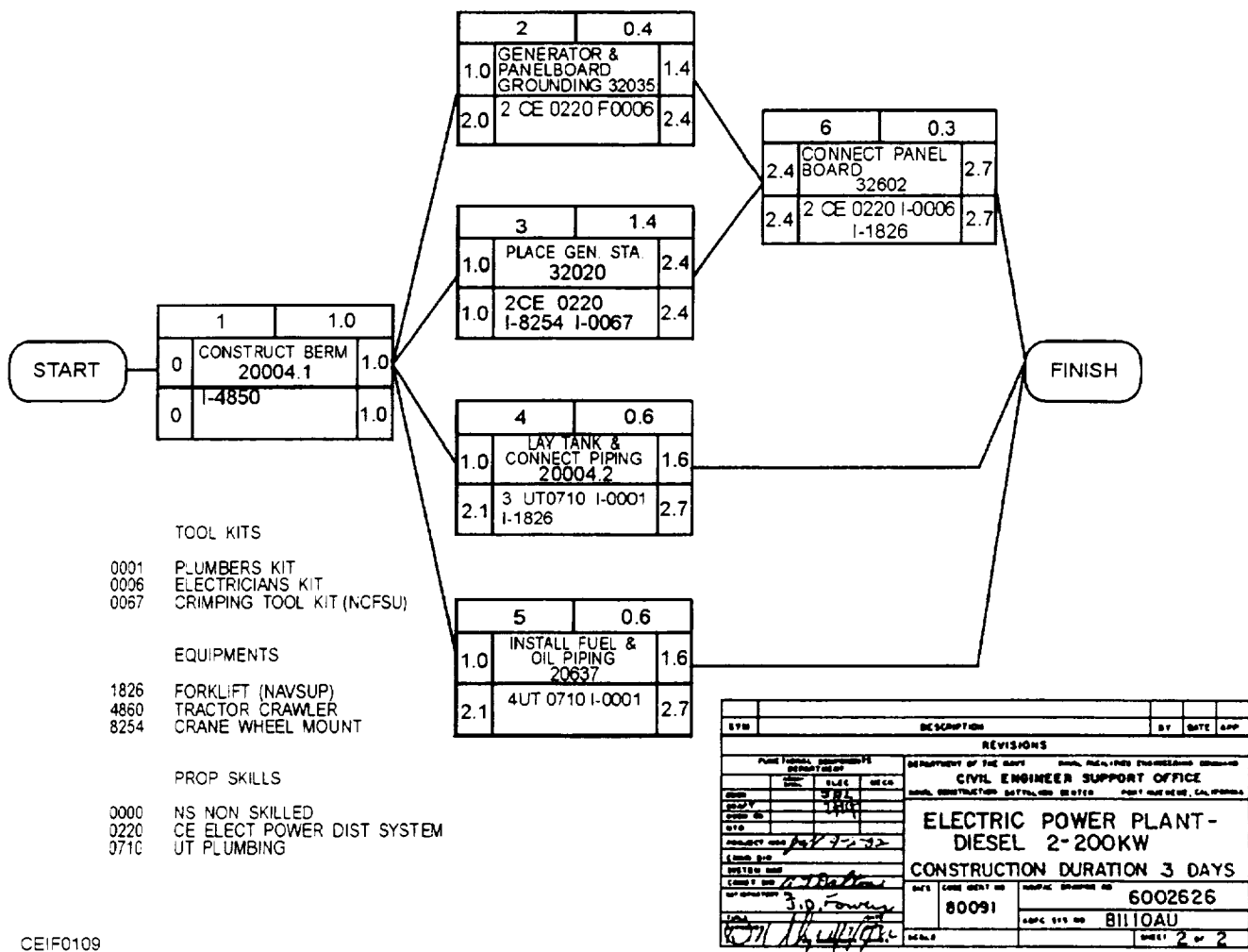

Figure 1-9.—Network diagram for installation of two 200-kilowatt generators.

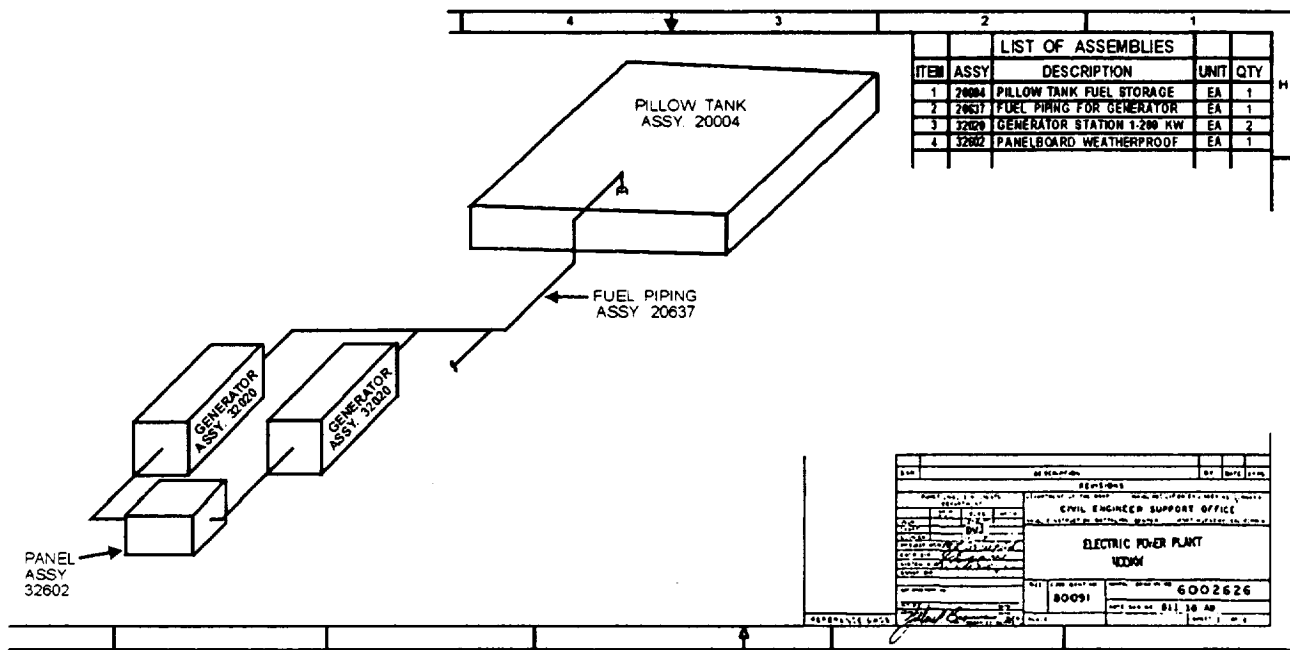

Figure 1-10.—Layout drawing for a 400-kilowatt electrical power plant.

Advantages

Network analysis has many advantages. As a management tool, it readily separates planning from scheduling of time. The diagram, a picture representation of the project, enables you to see the interdependencies between events and the overall project to prevent unrealistic or superficial planning. Resource and time restraints are easily adjustable to permit changes in the plan before its evaluation.

Because the system splits the project into individual events, estimates and lead times are more accurate. Deviations from the schedule are quickly noticed. Manpower, material, and equipment resources can be easily identified. Since the network remains constant throughout its duration, it is also a statement of logic and policy. Modifications of the policy are allowed, and the impact on events is assessed quickly.

Identification of the critical path is useful if the completion date has to be advanced. Attention can then be concentrated toward speeding up those relatively few critical events. The network allows you to accurately analyze critical events and provide the basis for the preparation of charts. This results in better control of the entire project.

Disadvantages

The only disadvantage of network analysis as a planning tool is that, when attempted manually, it is a

tedious and an exacting task. Depending upon just what the project manager wants as output, the number of activities that can be handled without a computer varies, but the number is never high. If calculations are in terms of the sequence of activities only, a project involving several hundred activities may be attempted manually. However, the chance for error is high. The time required for manual operation would become costly. Various alternative plans also may be impossible because of the large volume of work.

On the other hand, a standard computer program for network analysis, CBCM 2.1, can handle project plans and management and give the user the flexibility to select different alternatives from a list of available menus.

The project manager, NOT the computer, is still responsible for planning and must make decisions based on information supplied by the computer. Computer output is only as accurate as its input, which is supplied by people.

TIMEKEEPING

Timekeeping and labor reporting are of great importance to the operation of Seabee units. While these are functions of both NCF units and public works activities, the discussion in this chapter is limited to NCF units. As a Seabee crew leader, you may be involved in the preparation of daily time cards. Therefore, you should know the types of information

PROJECT QC PLAN

I. Project Number and Title:

II. Project Location:

III. Prime Contractor:

Subcontractor: (a)
(b)

IV. Project Scope:

V. Types of Testing Required (soil, concrete, etc.):

VI. Types of Associated Risk (fire, fumes, noise, etc.):

VII. Special Training Requirements:

VIII. Special License Required:

IX. Engineering Controls (guard rails, welding curtains, etc.):

X. Testing Equipment Required (state how it is to be used):

XI. Personal Protective Equipment Required for Testing:

Project Planner. _____
Print name, rate, and company/det

QC Chief: Approved/Disapproved _____
Signature

Reason for disapproval: _____

CEIF0113

Figure 1-13.—Project QC plan.

QUALITY CONTROL PLAN

PROJECT NUMBER: _____		PROJECT TITLE: _____		DATE: _____
ACTIVITY NUMBER	ACTIVITY DESCRIPTION	QUALITY CONTROL REQUIREMENT	SPECIFICATION REFERENCE	REMARKS / RESULTS

CEIF0114

Figure 1-14.—Quality control plan.

DAILY QUALITY CONTROL INSPECTOR'S REPORT			Route to	Initial	Date	Remarks
			S3			
			S3C			
			S3QC			
			00S			
			Prime			
Sub						
Date: _____		Time: _____		Project No.: _____		Report No.: _____
Prime Co.: _____			Project Title: _____			
Sub Co.: _____			Weather: _____			
Supervisor: _____			Inspector: _____			
Activity	Rate	Description of Work Performed				
Activities Started:			Activities Completed:			
QC Meetings Held: ___ Yes ___ No						
Construction Inspection Plan Items Checked:			Results:			
Delays:			Safety Hazards Present:			
Remarks:						
Material Received:						
I certify all work performed this date is IAW plans and specifications.						
Project Supervisor		QC Inspector		Reviewed (S3QC)		
Dist:	1. ROICC	2. QC File via S3	3. Prime Contractor	4. Crewleader		

CEIF0115

Figure 1-15.—Daily Quality Control Inspector's Report.

Naval Construction Force Occupational Safety and Health Program Manual, COMSECONDNCB/COMTHIRDNCBINST 5100.1, incorporates many naval instructions into a single document to establish policy, assign responsibility, promulgate, and implement the Naval Construction Force Occupational Safety and Health Program. Chapter 9 of this instruction deals with the Hazardous Material Control Program (HMCP). This Navy-wide program covers the proper storage, handling, usage, and disposal of HM. *Hazardous material*, as used in this instruction, follows the definition given for hazardous chemicals in 29 CFR 1910.1200 and Federal Standard 313B. Every command in the Navy will have an HMCP in place and each command will have the following responsibilities:

- Issue local instructions that incorporate the requirements of COMSECONDNCB/COMTHIRDNCBINST 5100.1 and 29 CFR 1910.1200 into a written hazardous communication program.
- Develop and update, on an annual basis, a complete inventory of all HMs used at the command. Include in the inventory the location, quantity, stock number, chemical or common name, shelf life where appropriate, and disposal requirements for each HM.
- Develop and implement an HM information and training program.
- Have available for review an Material Safety Data Sheet (MSDS) as required in 29 CFR 1910.1200 for each HM used or stored.

- For HM purchased locally, obtain an MSDS, or equivalent data sheet, at the time of purchase.

- Maintain a complete file of MSDS on the materials used, and make the MSDS or a worker-oriented summary of the MSDS information available to the users of the HM.

- Use the Type of Storage Codes listed in OPNAVINST 5090.1 to determine safe storage, handling, and use.

- Report HM mishaps according to OPNAVINST 5102.1, chapters 3 and 4, as appropriate.

- Comply with all requirements for disposal of HM required by OPNAVINST 5090.1; Title 40, Code of Federal Regulations, Parts 122 and 260-267; and state and local regulations.

- Indicate the presence of any HM on all shore equipment, tanks, pipes, or other stationary objects.

The established uniform policy, guidance, and requirements for the life-cycle control and management of HM are Navy policy, and you play an important role in its success. The safety of personnel is a vital concern and is the responsibility of all supervisors. Safety and health considerations for individuals are a fundamental element in the operation of all construction, facilities, equipment, and training. Tight schedules and adverse working conditions must not be accepted as excuses for relaxation of safety standards.”

CHAPTER 2

DRAWINGS AND SPECIFICATIONS

INTRODUCTION

Working with drawings and specifications (specs) is an essential part in your development as a Construction Electrician. You must be able to interpret, plan, estimate, and schedule construction projects, using the information supplied by the drawings and specifications. You will need to picture the separate operations mentally as the work progresses through the various stages of construction. You must use good judgment when determining what effect numerous factors and conditions have on a project and what allowances should be made for each of them. You must have ready access to information about the material, the equipment, and the labor required to perform various types of work under conditions encountered as part of the Naval Construction Force (NCF). In this chapter, we discuss this important phase of your work, that is, working with drawings and specifications.

Project concepts are developed by local activities. Their supporting documentation for a construction project is forwarded to NAVFACENGC, Engineering Field Division (EFD), for requirement validation, technical adequacy of the design solution, and reasonable cost estimate. Once a project has been designed, approved, and funded, it then must be accepted by COMSECOND/COMTHIRDNCB for tasking to the Seabee community. Your first encounter with a project that may have taken years to develop and fund will be the drawings and specifications.

From the beginning (a facility deficiency) to the end (a deficiency corrected), an involved process takes place. As a member of the NCF, you are the person who makes the needs and ideas of the naval community come to reality.

DEFINITIONS

To be able to work with, and from, drawings and specifications, you must know the terms commonly associated with planning, estimating, and scheduling. We have defined a few of the terms you will need to do your job. Read them with care, but do not try to

memorize them. Remember where you found them so you can refer to these terms whenever you have to use them.

Activity estimates consist of a listing of all the steps required to construct a given project. Activity quantities provide the basis for preparing the material, equipment, and manpower estimates. They are used to provide the basis for scheduling, material deliveries, equipment, and manpower.

Bill of material (BM) is a tabulated statement of the material required for a given project. It contains such information as stock numbers, unit of issue, quantity, line-item number, description, vendor, and cost. Sometimes the bill of material will be submitted on either material estimate sheets or material takeoff sheets; the two sheets contain similar information. Usually, the takeoff sheet is an actual tally and checkoff of the items shown, noted, or specified on the construction drawings and specifications.

Construction activities are a breakdown of master activities. They identify functional parts of the project and are often assigned to a particular company (Bravo/Charlie) or rating.

Detailed estimates are precise statements of quantities of material, equipment, and manpower required to construct a given project. Underestimating quantities can cause serious delays in construction or can result in unfinished projects. A detailed estimate must be accurate to the smallest detail to quantify requirements correctly.

Direct labor includes all the labor expended directly on assigned construction tasks, either in the field or in the shop, that contribute directly to the completion of the end product.

Equipment estimates consist of a listing of the various types of equipment, the amount of time, and the number of pieces required to construct a given project.

Estimating is the process of determining the amount and type of work to be performed and the quantities of material, equipment, and labor required.

Indirect labor includes labor required to support construction operations but does not, in itself, produce an end product.

Manpower estimates consist of a listing of the number of direct labor man-days required to complete the various activities of a specific project. These estimates may show only the man-days for each activity or they may be in sufficient detail to list the number of man-days for each rating.

Master activities consist of a breakdown of a complete project in sufficient detail to provide a comprehensive description of the project.

Material estimates consist of a listing and description of the various materials and the quantities required to construct a given project. Information for preparing material estimates is obtained from the activity estimates, drawings, and specifications.

Planning is the process of determining requirements and devising and developing methods and a scheme of action for construction of a project. Good construction planning is a combination of various elements: the activity, material, equipment, and manpower estimates; project layout; project location; material delivery and storage; work schedules; quality control; special tools required; environmental protection; safety; and progress control. All of these elements depend upon each other. They must be taken into account in any well-planned project.

Preliminary estimates are made from limited information, such as the general description of projects or preliminary plans and specifications having little or no detail. Preliminary estimates are prepared to establish costs for the budget and to program general manpower requirements.

Scheduling is the process of determining when an action must be taken and when materials, equipment, and manpower will be required. It shows the sequence, the time for starting, the time required for performance, and the time for completion.

SPECIFICATIONS

Specifications are written information about how a building or project is to be built. They are prepared under the direction of the architect and engineer. The type and quality, of materials, workmanship, finish, and final appearance are spelled out. The written specifications, along with the drawings, should give all the information needed to complete any project. Specifications control the actions and performance of

all parties who are working on or supplying material to a construction project. Specifications may be only a few pages long and give general instructions and specific information on materials. Short specifications are common in small construction jobs. In heavy construction, however, specifications may run hundreds of pages. Unless you understand how the various parts of the specifications interrelate, the sheer mass of the written material can be confusing. Specifications are composed of three major parts:

- Bid and contract forms
- General conditions
- Technical specifications

As an electrician, you will be working with specifications that deal with the technical areas related to your job. You will be responsible for the general and supplemental specifications, special conditions, and addenda or changes to conditions that may affect you.

The technical specifications spell out exactly what material is to be used, what standards are to be met, and what work is to be done in all areas of construction. The Construction Specification Institute (CSI) has developed a standard format that is widely followed to develop complete specifications. Bidding and contract requirements are covered in Division 0. Technical specifications are covered in Divisions 1 through 16. Division 17, expeditionary structures, was established specifically by NAVFAC. As you can see from table 2-1, the specifications are arranged in the sequence in which the project will progress, starting with bidding and contract requirements.

CONSTRUCTION DRAWINGS

The main basis for defining the required activities, measuring the quantities of material, and making accurate estimates is the information contained in construction drawings. You should read all notes and references carefully and examine all details and reference drawings thoroughly. You should check the orientation of sectional views carefully. Verify the Revision section near the title block to check whether the indicated changes were in fact made in the drawing itself. When inconsistencies are found between drawings and specifications, the specifications should take precedence.

Drawings are generally categorized according to their intended purposes: **preliminary drawings**, **presentation drawings**, **working drawings**, and **shop drawings**.

Table 2-1.—Technical Specifications

DIVISION #	AREA OF CONSTRUCTION
• Division 0	Bidding and Contract Requirements
• Division 1	General Requirements
• Division 2	Site Work
• Division 3	Concrete
• Division 4	Masonry
• Division 5	Metals (Architectural and Structural)
• Division 6	Wood and Plastics
• Division 7	Thermal and Moisture Protection
• Division 8	Doors and Windows
• Division 9	Finishes
• Division 10	Specialties
• Division 11	Equipment
• Division 12	Furnishings
• Division 13	Special Construction
• Division 14	Conveying Systems
• Division 15	Mechanical
• Division 16	Electrical
• Division 17	Expeditionary Structures

A building project may be broadly divided into two major phases: the design phase and the construction phase. First, the **preliminary drawings** are prepared during the design phase. They are prepared by the EFD or by an architect's and engineer's (A/E) firm. The preliminary drawings are used for exploring design concepts between the designer and the user (customer), making material selection, getting preliminary cost estimates, and serving as a basis for preparing the finished working drawings.

The **presentation drawings** are developed to show the proposed building or facility in an attractive setting in its natural surroundings at the proposed site. Since these drawings are actually used to sell an idea or

a design, you will probably see this type of drawing only as a cover sheet to a set of construction drawings.

In the second phase, after approval has been given for construction, the **working drawings** are developed. **Shop drawings** are supplied by manufacturers to show fabrication of building parts. After review by the architect and engineer, they become a part of the working drawings. Throughout your career, you will hear working drawings referred to as blueprints, construction drawings, prints, or plans. Basically, these terms are all correct; they can be used interchangeably.

As mentioned earlier, the construction drawings are developed from the preliminary drawings. With the collaboration of the EFD and the architect and the engineer, both the materials to be used and the

construction methods to be followed are decided. The engineer determines the loads that the supporting structural members will be required to bear and designs the mechanical systems, such as heating, power, lighting, and plumbing.

As a crew member or a supervisor, you will find the construction drawings, the specifications, and the bill of material your main sources of information during the construction and estimating phases of the project.

Drawings are commonly indexed so you can easily find the sheet you need. The drawing index is located on the cover sheet or sheet 1 of the set. They are divided into eight categories and appear in the following order:

1. Plot and vicinity
2. Landscape and irrigation
3. Architect
4. Structural
5. Mechanical
6. Plumbing
7. Electrical
8. Fire protection

WORKING SKETCHES

A working sketch is a drawing made from the working drawings to express a tasking clearly and to provide a quick reference to job requirements. It is drawn to help show actual conditions on the job, what size pipe is to be installed, or where connections will be made. The sketch should show as much detail as possible to help your crew during installation or troubleshooting. A working sketch will usually show the work you want your crew to accomplish in a selected area and will provide ready reference to jobsite conditions.

A crew should have a working sketch with them while working. It will show them how, what, where, and when things happen in the sequence of the job. Your first step in making a working sketch should be to draw the symbols that represent all the fixtures or equipment that is to be installed and locate them within the room. Try to draw them in the sequence of installation and include measurements. The amount of detail you use in a working sketch will be determined by the crew's experience, the complexity of the systems involved, and the need for cooperation with other trades working on the jobsite.

AS-BUILT DRAWINGS

Upon the completion of a facility, the crew leader or project supervisor should provide marked prints that indicate any construction deviations. The information required must show all features of the project as actually, built. As-built drawings should be reviewed after they are completed. This review assures that all information appearing on the drawings shows the exact as-built conditions.

From the as-built drawings, record drawings are prepared. These drawings are the original construction drawings, but they are corrected according to the as-built marked print. They then provide a permanent record of as-built conditions. The final record drawings must be kept up to date at all times. If this maintenance requires a change to the record drawing, then this information should be passed on and the record drawings updated.

BLUEPRINT LANGUAGE

To understand the instructions and dimensions on a working drawing, you must be able to read and understand the language of the prints not only for your particular job but also for all the different phases. Plans, specifications, and details go together. It is impossible to use one successfully without the other. Never overlook a reference note on a drawing. The blueprints contain the information and directions that require you to do your part of the total job as planned. It is also important to follow all the instructions on a blueprint faithfully. Any deviation on your part may make it impossible for fellow tradesmen to do their work properly or successfully.

To read blueprints, you must understand the meanings of all devices, such as various lines, symbols, conventions, abbreviations, and methods of giving dimensions and working directions.

TYPES AND WEIGHTS OF LINES FOUND ON DRAWINGS

The types of lines the electrician should be able to read and understand are given below. In figure 2-1 these lines are shown as they may appear on a drawing.

Trim line: a light, continuous line along which the tracing is trimmed to square the sheet.

Border line: a heavy, continuous line that outlines or borders the drawing. The drawing is complete within this lined border.

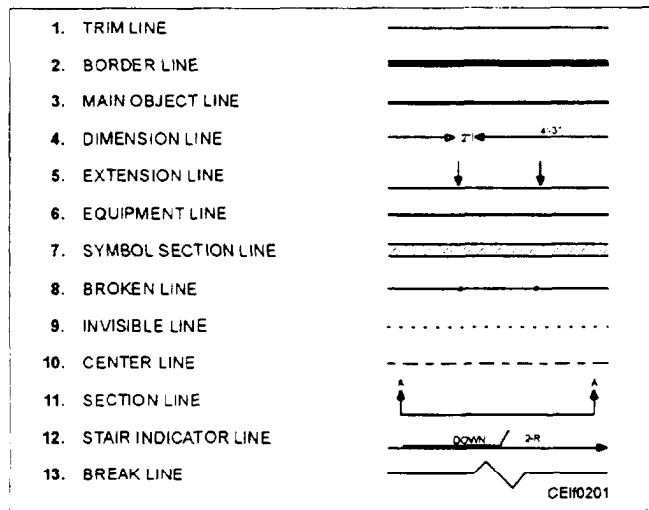

Figure 2-1.—Construction drawing lines.

Main object line: a heavy, unbroken line used to show visible outlines or edges that would be seen by people looking at the article, house, or building. The main object line is one of the most important lines because it outlines the main wall lines on plans and sections. It shows clearly the important parts of the construction and emphasizes the outline of the elevations.

Dimension line: a light line drawing outside the structure or detail to show the distance between two points. This line is drawn between extension lines with an arrowhead on each end. Between the arrowheads, the distance will be given either at a break in the line or just above the line. On some drawings the scale and the distance between the two points may not agree; in such cases, the distance will be given in a dimension line.

Extension line: a line that touches and is used with dimension lines. This line extends out from the edge or the point at which the dimension is to be determined.

Equipment line: a light, continuous, unbroken line used to show the location of equipment, such as transformers, panels, and galley equipment. This line is used to allow the electrician to install the necessary conduit in the proper location during rough-in work.

Symbol section line: lines that are generally solid, although, for certain conventions, dotted lines of the same weight may be used. Section lines, evenly spaced, are used to shade surfaces shown on a drawing and by these means indicate the material used. Material section lines are standardized to a certain degree, but you will find some variations. A set of working drawings using these symbols would have a symbol schedule key showing the various materials in that

particular set. This schedule is usually placed near the title box on the plan of the first floor.

Broken line: a line with wavy breaks in it, at intervals, used to indicate those parts that have been left out or that the full length of some part has not been drawn. The broken line is used in detail drawings where only a section of the object is to be shown.

Invisible line: a line that is made up of a series of short dashes. It is used to indicate a hidden or an invisible edge or edges that are hidden under some other part of the structure.

Center line: a line that is made up of alternating long and short dashes and is used to indicate the center of an object.

Section line: a solid line that has arrowheads at each end that point in the direction in which the section is to be taken. This line tells just where the section has been cut through the wall or building. The sections are indicated, in most cases, by the letters *A-A*, *B-B*, and so forth, although numbers are sometimes used. Do not overlook these section lines on a plan. To obtain a clear picture of the construction at the particular point indicated, always refer to the section detail called for by the letter or number.

Stair indicator line: a solid line with an arrowhead indicating the direction of the run. For example, Up 12-R means that there are 12 risers from floor to floor and that the stairs go up. A riser is the vertical part of the step; the flat part on which one steps is the tread. In most cases, the floor plan indicates only the run of stairs half the distance between floors. For example, the ground floor indicates a broken line that tells you the steps continue up. The next floor plan shows the stair indicator line half the distance to the first floor, down.

Break line: a thin solid ruled line with freehand zigzags used to reduce the size of a drawing required to delineate an object and reduce detail.

ABBREVIATIONS AND SYMBOLS

Blueprints show a small-scale drawing of a full-size building. Since the blueprints are small in relation to the actual building, some kind of shorthand is needed to give the necessary building information. Abbreviations and symbols are used to show a large amount of information in a small space.

While there is some standardization of symbols and abbreviations, a lot of variation still exists. A key or legend is put on the blueprint to explain their uses.

An abbreviation is a shortened form of a word. Sometimes the same abbreviation is used for different words. The specific meaning of an abbreviation can be determined by its use on the blueprint. Abbreviations are used in notes or as specific characters on the blueprints. The area referred to will give a hint to the meaning of the abbreviation.

Symbols are used on blueprints to represent materials, equipment, electrical, mechanical, plan, elevations, and sections (figs. 2-2 through 2-9). They are used as a simple way of representing a fact. Most drawings have a legend of symbols which, when combined together with the specifications, describes a building thoroughly.

SCHEDULES

The schedule is a systematic method of presenting notes and information in a tabular form for the purpose of making it easily accessible to the craftsman and specification writer. One example of a commonly used lighting fixture schedule is shown in figure 2-10. Similar schedules such as the room finish schedule and the mechanical equipment schedule (not shown) are very helpful and also should be reviewed.

SCALE REPRESENTATION

An architect cannot make his drawings full size. For convenience, he reduces all dimensions to some

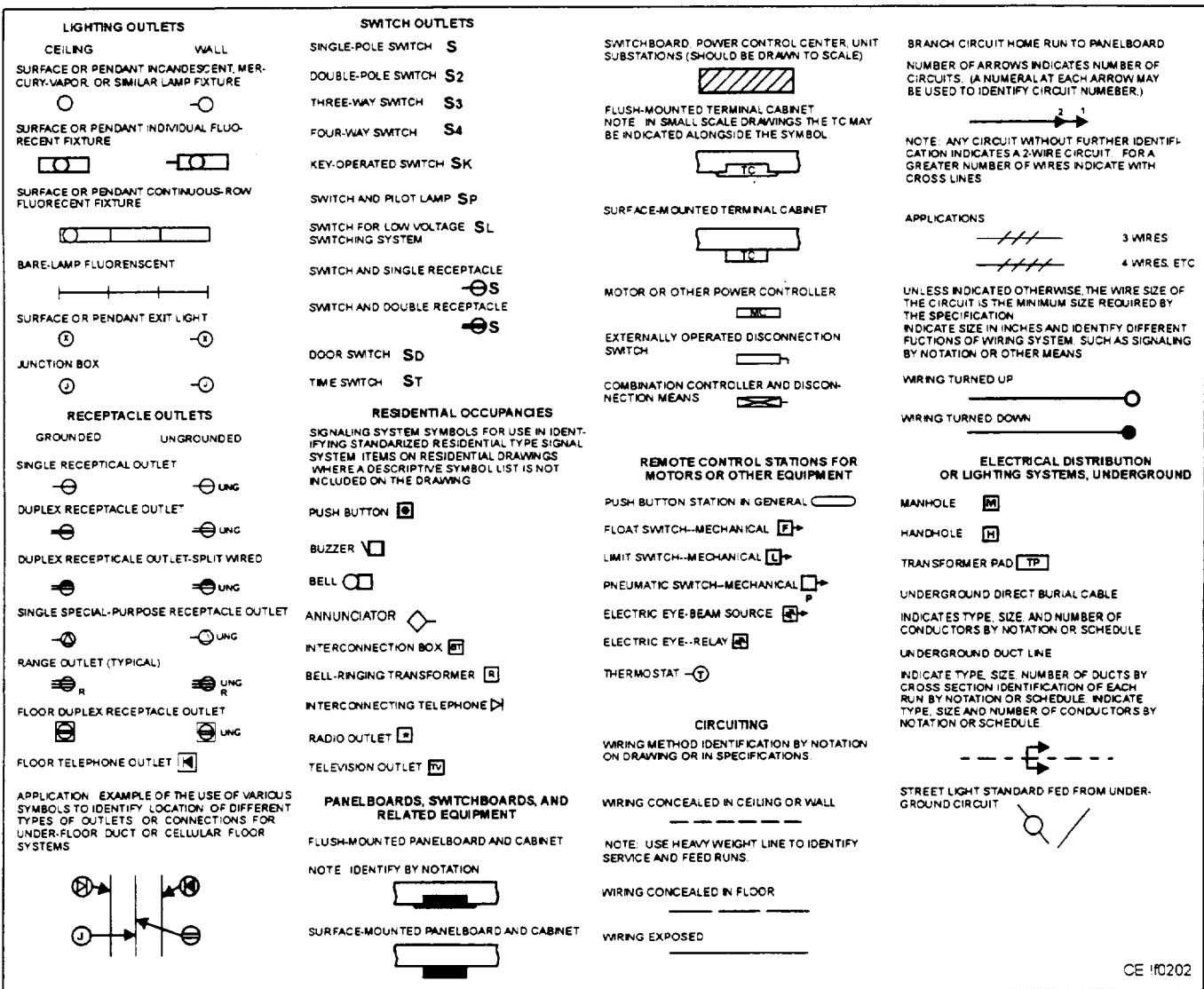











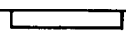

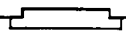



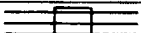
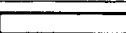







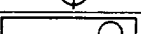

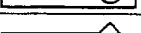







Figure 2-2.—Electrical symbols.

ELECTRICAL (WIRING)	
GENERAL	SWITCHES
 = CONDUIT EXPOSED (CROSS HATCH INDICATES NO. OF CONDUCTORS)	S = SINGLE-POLE SWITCH
 = CONDUIT CONCEALED IN CEILING OR WALL	S₂ = DOUBLE-POLE SWITCH
 = CONDUIT CONCEALED IN OR UNDER FLOOR	S₃ = THREE-WAY SWITCH
 = UNDERGROUND DIRECT BURIED CABLE	 = CEILING-PULL SWITCH
 = WIRE WAY	S_{WP} = WEATHERPROOF SWITCH (LETTERS DESIGNATE SWITCH TYPE)
 = BUS DUCT	
 = CONDUIT-UP	
 = CONDUIT-DOWN	
 = GROUNDED WIRING	
	RECEPTACLES
PANELS	 = DUPLEX RECEPTACLE
 = SURFACE-MOUNTED PANEL	 = DUPLEX RECEPTACLE, SPLIT-WIRED
 = FLUSH/RECESSED PANEL (DESIGNATE)	 = FLOOR OUTLET (ATTACH ADDITIONAL SYMBOL FOR RECEPT., TEL., etc.)
 = BRANCH CIRCUIT PANEL	 = SPECIAL-PURPOSE OUTLET (DESIGNATE)
 = DISTRIBUTION PANEL	 = UNDER FLOOR DUCT & JUNCTION BOX (NUMBER OF LINES INDICATE NUMBER OF DUCTS)
 = CONTROLLER (DESIGNATE)	 = JUNCTION BOX (LOCATE)
 = PULL BOX	 = TELEPHONE OUTLET
	 = INTERCOM OUTLET
CIRCUITS	 = CEILING LIGHT OUTLET
 = BASIC CIRCUIT - (2 WIRE)	 = WALL-MOUNTED OUTLET
 = ADDITIONAL WIRES - (INDICATES NUMBER WITH CROSS LINES)	 = FLUORESCENT FIXTURE
 = PRIMARY CIRCUIT	 = PAGING SYSTEM DEVICES
 = HOME RUN BRANCH CIRCUIT TO PANEL (NO. OF ARROWS INDICATES NO. OF CIRCUITS & NO. BELOW DESIGNATES CIRCUIT BREAKER TERMINAL)	 = MOTOR (APPLICATION)
	 = FIRE ALARM HORN
	 = FIRE ALARM BELL
	 = FIRE ALARM SENDING STATION

CE#0203

Figure 2-3.—Additional electrical symbols.

HEATING

SYMBOL	ITEM	SYMBOL	ITEM
	RADIATOR, FLOOR		VENTILATOR, STANDARD ROOF
	VENTILATOR, COWL, ROUND OVAL		FAN, AXIAL WITH PREHEATER FREE INLET
	DAMPER, VOLUME		FAN, CENTRIFUGAL
	HEAT TRANSFER SURFACE		DAMPER, DEFLECTING DOWN
	HEATER, CONVECTION		DAMPER, DEFLECTING UP
	HEATER UNIT, CENTRIFUGAL FAN		DUCT
	HEATER UNIT, PROPELLER TYPE		DUCT, DIRECTION OF FLOW IN
	RADIATOR, WALL		VANES
	VENTILATOR UNIT		GRILLE
	HEATER, DUCT TYPE		REGISTER
	DAMPER		

PLUMBING

SYMBOL	ITEM	STD ABBR	SYMBOL	ITEM
	DISHWASHER DRAIN	DW		SHOWER STALL
	DRINKING FOUNTAIN**	DF		WATER CLOSET
	FLOOR DRAIN	FD		WATER CLOSET, WALL HUNG
	ROOF DRAIN TRAP	RD		WATER CLOSET, LOW TANK
	GREASE TRAP	GT		BATH
	BATH, DISHWASHER LAVATORY**	B, DW, L, R, S, ST		URINAL, STALL TYPE OR AS SPECIFIED
	RANGE SINK**			URINAL, CORNER TYPE
	STEAM TABLE			URINAL, TROUGH TYPE
	CAN WASHER DENTAL UNIT	CW, DU		URINAL, WALL TYPE
	HOT WATER TANK	HWT		LAVATORY, CORNER
	WATER HEATER	WH		LAVATORY, WALL
	WASH FOUNTAIN	WF		ELECTRIC WATER COOLER
	CLEANOUT	CO		
	GAS OUTLET	G		
	HOSE FAUCET	HF		
	LAWN FAUCET	LF		
	HOSE BIB	HB		
	WALL HYDRANT	WH		
	FLOOR DRAIN WITH BACKWATER VALVE			
	SHOWER HEAD			
	SHOWER HEADS, GANG			

* STANDARD ABBREVIATION INCLUDED WITH SYMBOL

** TYPE SHOULD BE GIVEN IN SPECIFICATION OR NOTED WHEN THIS SYMBOL IS USED

PIPE FITTINGS, VALVES AND PIPING	PIPE FITTINGS, VALVES AND PIPING					PIPE FITTINGS, VALVES AND PIPING (CONT.)	PIPE FITTINGS, VALVES AND PIPING (CONT.)				
	FLANGED	SCREWED	BELL & SPIGOT	WELDED	SOLDERED		FLANGED	SCREWED	BELL & SPIGOT	WELDED	SOLDERED
ELBOW						TEE					
45-DEGREE						STRAIGHT SIZE					
90-DEGREE						OUTLET UP					
TURND DOWN						OUTLET DOWN					
TURND UP						DOUBLE SWEEP					
BASE						REDUCING					
DOUBLE BRANCH						SINGLE SWEEP					
UNION						PLUMBING SYMBOLS					
GATE VALVE						CLEANOUT					
GLOBE VALVE						DRAIN					
SAFETY VALVE						GREASE TRAP					
REDUCER CONCENTRIC						WATER HEATER					
REDUCER ECCENTRIC						HOT WATER TANK					
SLEEVE											

CEIf0204

Figure 2-4.—Heating, plumbing and pipe fitting/value symbols.

ITEM	ILLUSTRATED	SYMBOLS (THREADED)	ITEM	SYMBOL	SAMPLE APPLICATION (S)	ILLUSTRATION
90 ELBOWS			PIPE	SINGLE LINE IN SHAPE OF PIPE—USUALLY WITH NOMINAL SIZE NOTED		
STRAIGHT TEE			JOINT-FLANGED	DOUBLE LINE		
REDUCING TEE			SCREWED	SINGLE LINE		
SANITARY TEE			BELL AND SPIGOT	CURVED LINE		
P-TRAP			OUTLET TURNED UP	CIRCLE AND DOT		
GATE VALVE			OUTLET TURNED DOWN	SEMICIRCLE		
SHOWER HEAD			REDUCING OR ENLARGING FITTING	NORMAL SIZE NOTED AT JOINT		
LAVATORY (SINKS)			REDUCER CONCENTRIC	TRIANGLE		
BATH TUBS			ECCENTRIC	TRIANGLE		
SHOWER STALL			UNION SCREWED	LINE		
			UNION FLANGED	LINE		



ITEM	SYMBOL		ILLUSTRATION
	STRAIGHT	ANGLED	
CHECK VALVE			
GATE VALVE-PLAN			
ELEVATION			
GLOBE VALVE-PLAN			
ELEVATION			
FLOAT VALVE			
HOSE VALVE			
PET COCK			
TRY COCK			

NOTE: SYMBOLS ARE SHOWN FOR SCREWED FITTINGS—SYMBOLS FOR JOINTS ARE ADDED FOR OTHER TYPES





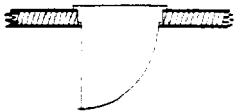

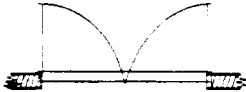
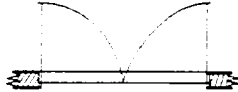
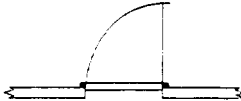
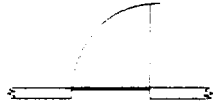
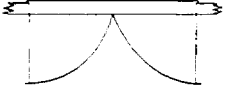
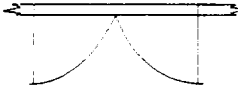
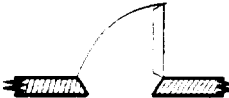
CEI#0205

Figure 2-5.—Mechanical and plumbing symbols.

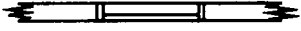
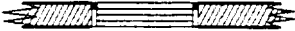
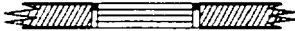
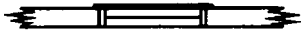
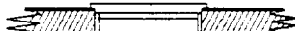
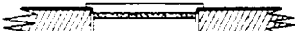
DOOR SYMBOLS

TYPE	SYMBOL	
SINGLE-SWING WITH THRESHOLD IN EXTERIOR MASONRY WALL SINGLE DOOR, OPENING IN		
DOUBLE DOOR, OPENING OUT		
SINGLE-SWING WITH THRESHOLD IN EXTERIOR FRAME WALL SINGLE DOOR, OPENING OUT		
DOUBLE DOOR, OPENING IN		
REFRIGERATOR DOOR		

WINDOW SYMBOLS

TYPE	SYMBOL		
	WOOD OR METAL SASH IN FRAME WALL	METAL SASH IN MASONRY WALL	WOOD SASH IN MASONRY WALL
DOUBLE HUNG			
CASEMENT			
DOUBLE, OPENING OUT			
SINGLE, OPENING IN			

CE10206

Figure 2-6.—Architectural symbols for doors and windows.

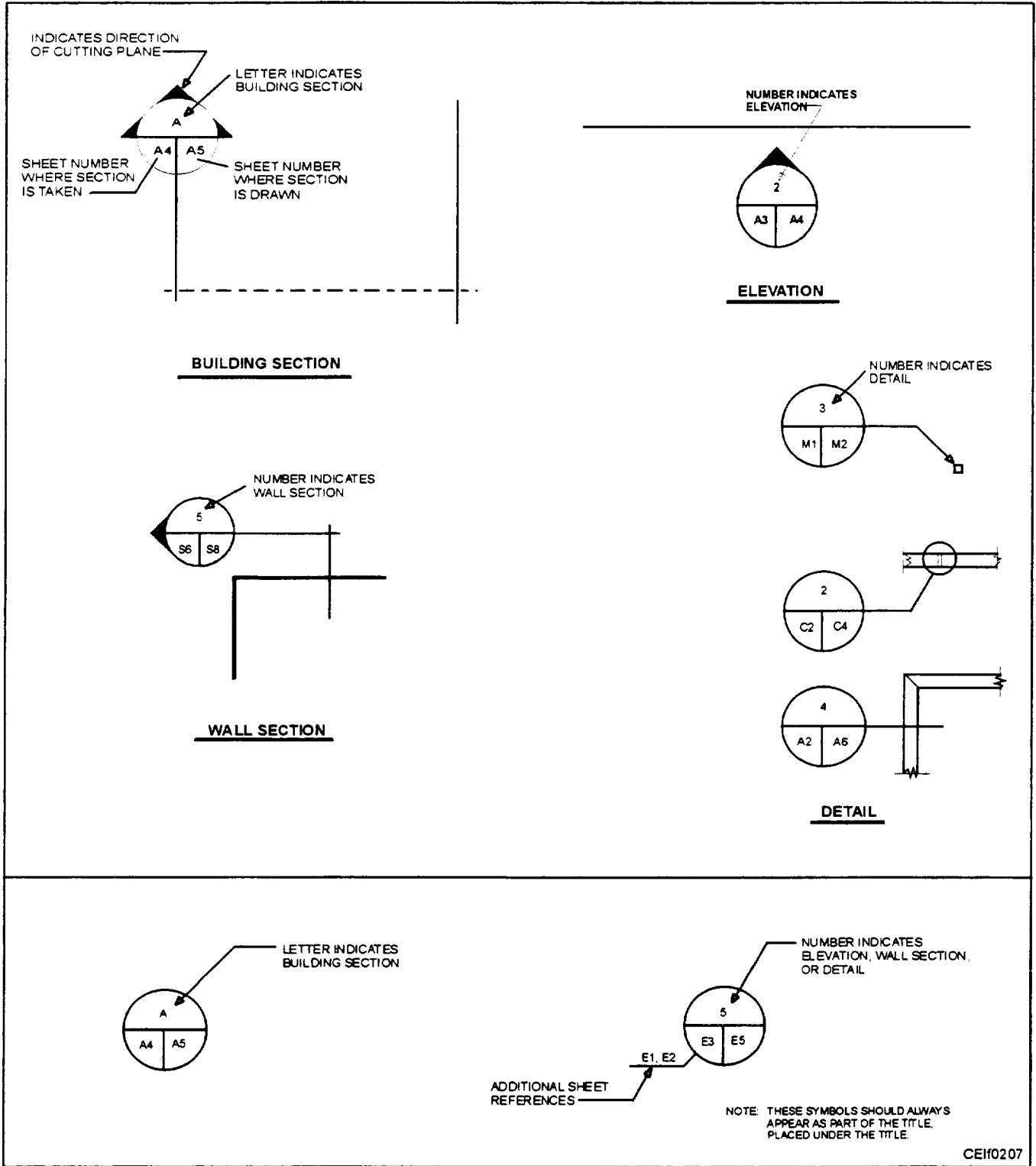

CEI10207

Figure 2-7.—Title symbols.

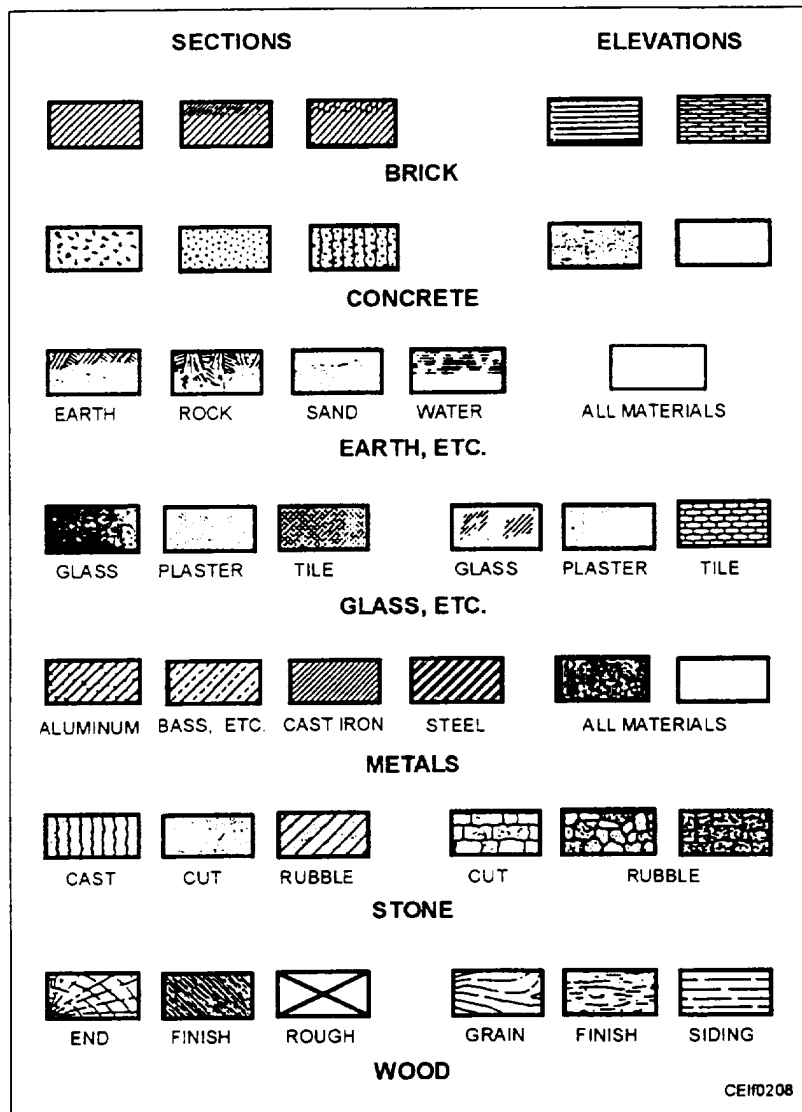

Figure 2-8.—Architectural symbols for plans and elevations.

scale. He selects some smaller dimension to represent a foot and reduces all dimensions to this unit. A floor plan or an elevation is often drawn at 1/48 the size of the real building. A drawing 1/48th size would be drawn at a scale of 1/4" = 1'0". Each 1/4 inch on the drawing equals 1 foot on the actual building. Different scales are used to show different areas of the drawings. While floor plans and elevations are commonly drawn 1/4" = 10', detail drawings are drawn at a larger scale, usually 1" = 10'. Sometimes full-scale drawings are used to show a small detail. The scale is normally noted in the title block or beside each drawing on the print.

Scaled drawings are made using an architect's scale (fig. 2-11). An architect's scale has 11 scales (table 2-2). The numbers at each end of the architect's scale designate the scale. Figure 2-12

shows an enlarged view of part of a 1/4-inch scale. Each division on the scale equals 1 foot on the actual building. The small divisions to the right equal 1 inch on the building, thereby allowing more accurate measurement. This scale is read from right to left. Architects and drafters use an architectural scale to draw blueprints. Figure 2-13 shows how the scale is used to check a measurement on a blueprint. Note how the small divisions (at the right) are used to get exact measurements; in this case, 8 feet 8 inches.

MODULAR DIMENSIONS

Some blueprints are drawn so that features on the structure fall within a set module or measure. A modular system is based upon a grid with a set measure, normally 4 inches or a multiple of 4 inches, such as 16, 24, or 48 inches. Walls, floor levels, and

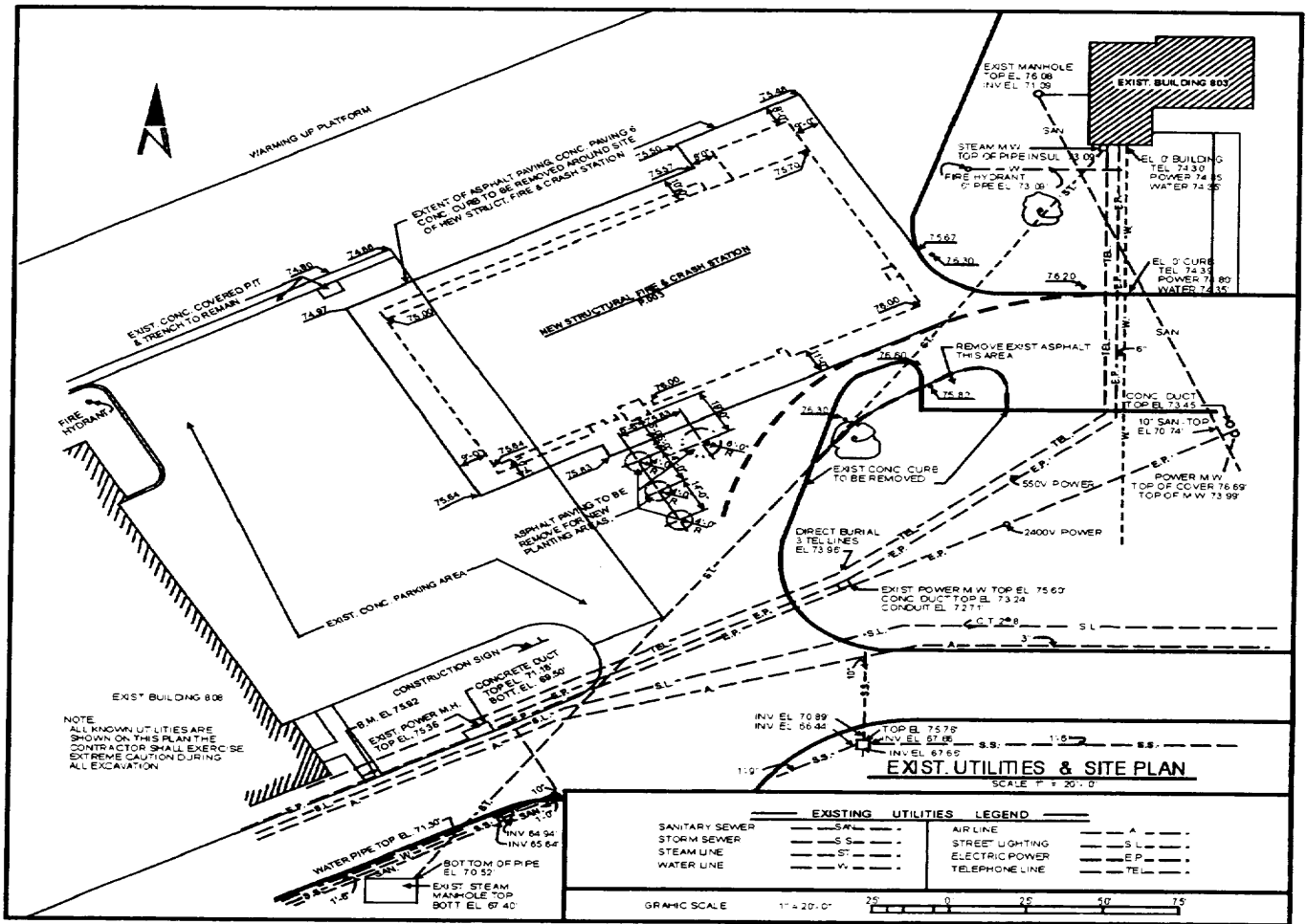

Figure 2-9.—Plot plan, contours, and symbols.

openings are dimensioned to fall on 4-inch modular lines. This approach reduces building costs by coordinating building sizes with standard-sized building materials. For example, studs with finish are approximately 4 inches thick and are spaced on 16- or 24-inch centers. Plywood panels and drywall sheets come in standard 4-foot by 8-foot sheets.

Figure 2-14 shows a modular light-frame house used for a small residential building. The building is laid out in such a way that standard modular-based building materials can be used. Often, modular

construction is used to develop complete, finished panels or rooms. This process allows standard-size building parts to be fabricated, taken to the building site, and erected into place.

METRIC DIMENSIONS

Metric measurement is becoming more common in the United States on construction working drawings. NAVFAC drawings now have dimensions in both metric and English. The metric scale is used in place of the architect's and engineer's scales when measurements and dimensions are in meters and centimeters.

LIGHTING FIXTURE SCHEDULE					
MARK	DESCRIPTION	MTG	VOLT	LAMPS	REMARKS
A	ALKCO # EXPRC-210-2E/120V/GREEN LETTER, ON CLEAR	CEILING	277	(2) 6 WT5	W/FLASHER
B	METALUX # SS 240-277-ES	PENDANT	277	(2)F40/WW/RS/ WMII	W/1 ½ HR BATT PACK
C	ROBERT MFG # 72-240-277-ES	SURFACE	277	(2)F40/WW/RS/ WMII	W/1 ½ HR BATT PACK
D	METALUX # HR-2GP-ASR-3 40A-125-277-LE3	RECESSED	277	(3)F40/WW/RS/ WMII	BLDG STANDARDS
E	CROUSE-HINDS # VXHB15GP	WALL	120	(1)150W/A21/ 130V	
F	METALUX # HR-2GP-ASR-3 40A-125-277-LE3	RECESSED	277	(3)F40/WW/RS/ WHII	BLDG STANDARDS W/1 ½ HR BATT PACK
G	SURE LITE # SWV-36	RECESSED	120/6	SUPPLIED W/ FIXTURE	W/1 ½ HR BATT PACK
H	METALUX # SS 230-277-ES	COVE	277	(2)F40/WW/RS/ WM	
I	METALUX # SS 240-277-ES	PENDANT	277	(2)F40/WW/RS WMII	
J	LIGHTOLIER # JAW04II	WALL	120	(1)60W/G-40/CL	BLACK W/CLEAN SPHERE

CEIF0210

Figure 2-10.—Commonly used lighting fixture.

Table 2-2.—Architect's Scales

SCALE	RELATION OF SCALE TO OBJECT
16	Full Scale
3	3" = 1'-0"
1 1/2	1 1/2" = 1'-0"
1	1" = 1'-0"
3/4	3/4" = 1'-0"
1/2	1/2" = 1'-0"
3/8	3/8" = 1'-0"
1/4	1/4" = 1'-0"
3/16	3/16" = 1'-0"
1/8	1/8" = 1'-0"
3/32	3/32" = 1'-0"

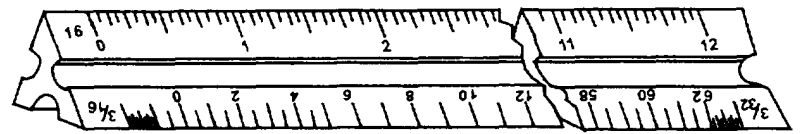
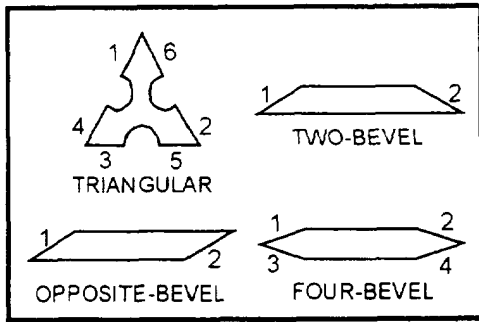

TRIANGULAR SCALE
 16, 3/16 AND 3/32 SCALES ARE SHOWN.
 16 SCALE IS SUBDIVIDED INTO SIXTEENTHS.
 ALL OTHERS ARE SUBDIVIDED INTO TWELFTHS.

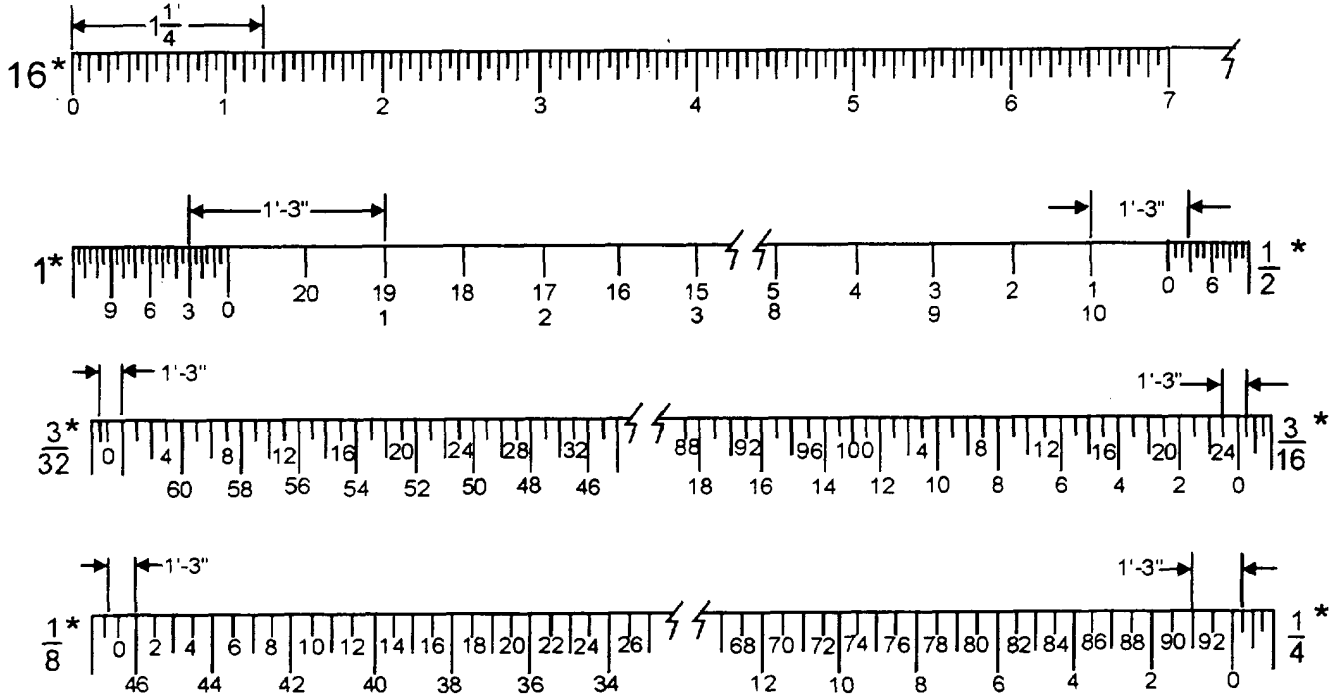

READING SAMPLE SCALES

1'-3" SHOWN ON THE 16, 1, 1/2, 3/32, 3/16, 1/8, AND 1/4 SCALES.
 ON 3/16, 1/4, AND 1 SCALES, READ BOTTOM NUMBERS.
 ON 3/32, 1/8, AND 1/2 SCALES, READ TOP NUMBERS.

CEIF0211

*SCALE DESIGNATION

Figure 2-11.—Architect's scale.

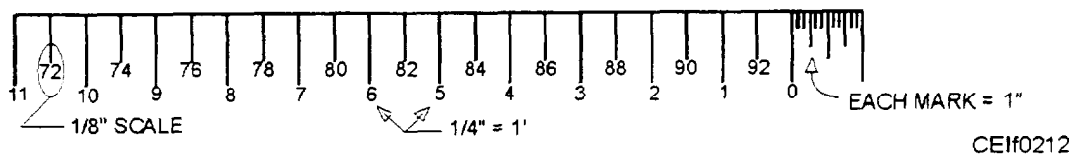

Figure 2-12.—Enlarged view of part of a 1/4-inch scale.

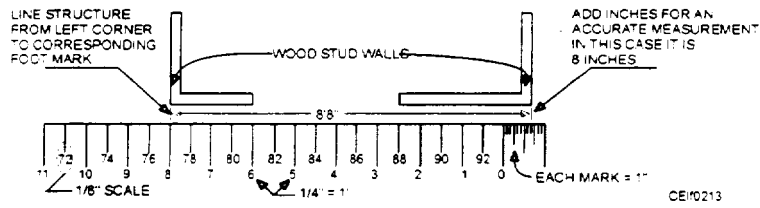

Figure 2-13.—Using a scale to check a measurement on a blueprint.

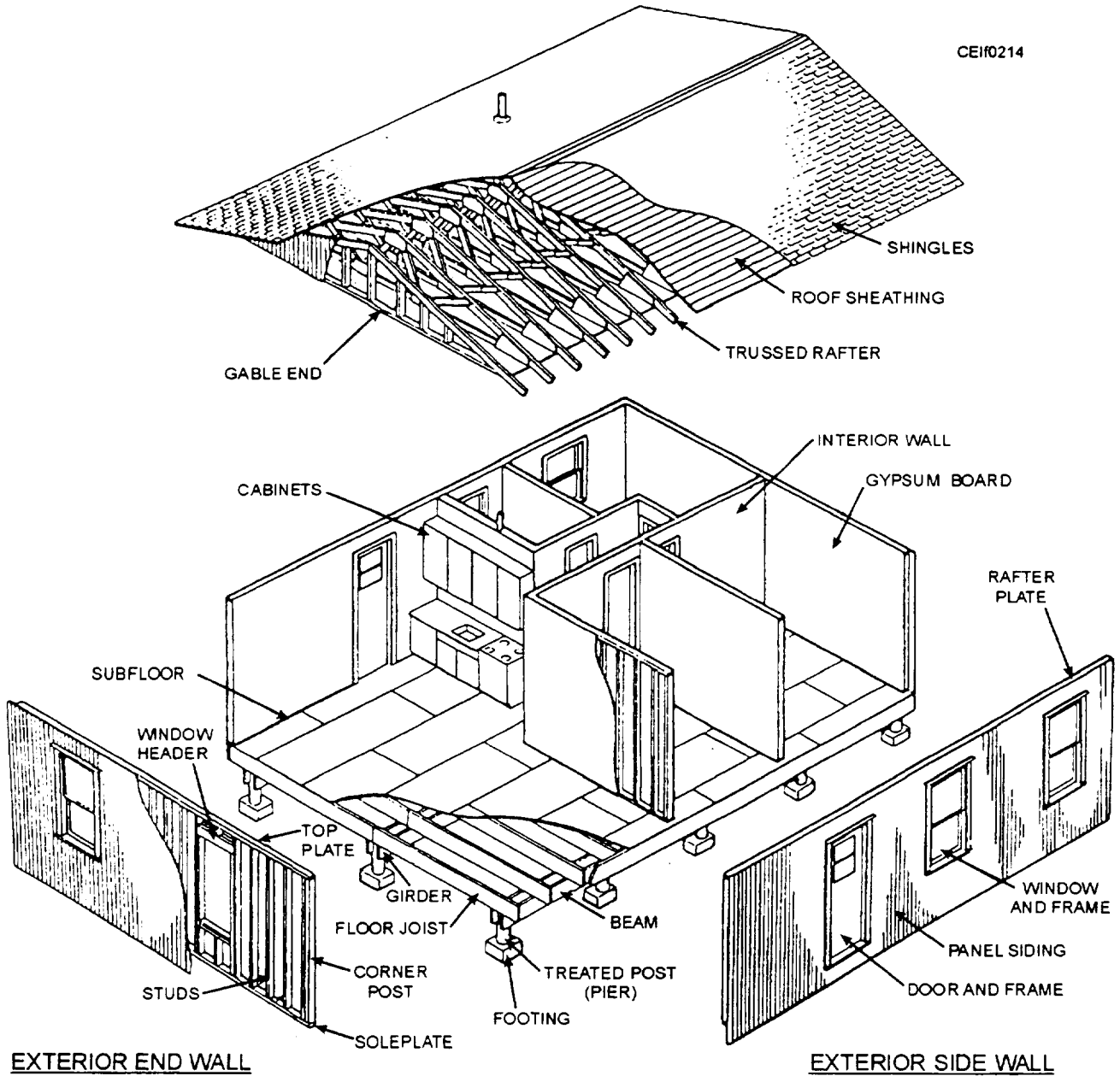

Figure 2-14.—Exploded view of a typical light-frame modular house.

When you are using scales on a drawing, do not confuse the engineer's scale with a metric scale. They are very similar in appearance. You will often find metric dimensions used on blueprints from other countries. Metric drawings are dimensioned in millimeters (mm). There are 25.4 millimeters to an inch. A meter is 39.37 inches, a few inches longer than a yard measure.

Scales of 1:100 and 1:200 are common scales for metric drawings. One millimeter on the drawing represents 100 or 200 millimeters on the actual building.

Metric blueprints developed in the United States are normally marked "METRIC." In countries that use metric, however, no metric notations are made.

CHAPTER 3

GENERATORS

INTRODUCTION

As a Construction Electrician, you may have the responsibility for the installation, maintenance, and repair of electrical power generation equipment. In time of war or national emergency, Advanced Base Functional Components (ABFC) will normally be used at temporary overseas bases. Even in peacetime, generation equipment is used at remote bases or as emergency and backup power on most naval bases.

A power distribution system includes all parts of an electrical system between the power source and the load. This chapter gives the correct procedures for the operation and maintenance of power plants and distribution systems and presents technical information for the selection and installation of power-generating plants.

POWER GENERATION

The characteristics built into naval electrical installations are simplicity, ruggedness, reliability, and flexibility to permit continued service. It is the function of those who operate these plants to make full use of the installation's inherent capabilities and to maintain, as far as possible, uninterrupted availability of electrical power where it is needed. To be able to do this, operating personnel should possess the following:

- A thorough knowledge of how to operate and maintain the components of an electrical plant
- A complete familiarity with the electrical plants distribution capabilities
- An understanding of the electrical system operation of the base
- The ability to apply electrical and electronic principles to specific installations
- The sizing and installation of secondary conductors

EMERGENCY/STANDBY POWER

When you set up an emergency/standby power system, numerous factors must be considered. The following text will cover a few of the possible

situations you may encounter. This chapter does not include the automatic transfer aspect of switching to backup power, since this task is performed by someone with a Navy Enlisted Classification (NEC) code, CE-5601 Uninterruptible Power Supply (UPS). For our discussion in this section, we will be using the term emergency-the concepts involved are equally applicable to "standby" systems. Remember that the National Electrical Code® requires emergency and standby systems to be kept entirely separate from all other wiring and equipment. For more detailed information, see article 700 of the National Electrical Code®.

SYSTEM DESIGN

Whether you are designing and installing an emergency backup system or operating and maintaining an existing system, you must be completely familiar with the installation requirements and the physical characteristics of the equipment. The design, material, and installation must comply with electrical safety standards and codes.

In general, when emergency power is discussed, it is assumed to be replacing "normal" power. The choice of arrangement and the size and the type of equipment depend in large measure on the loads to be fed from the emergency system. The system includes all devices, wiring, raceways, transfer switch, energy source, and other electrical equipment required to supply power to selected loads. These selected loads will be determined by the available power from your emergency power source. Figures 3-1 and 3-2 show two possible arrangements for emergency/standby power hookups.

GENERATOR SELECTION

When an overseas base is first established and electrical power is required in a hurry, you will not have time to set up a centrally located generating station; instead, you will spot a portable plant at each important location requiring power. Table 3-1 lists some of the standard alternating current (ac) generators available. These standard generators are capable of meeting the power requirements of advanced bases and also those for permanent or portable emergency power.

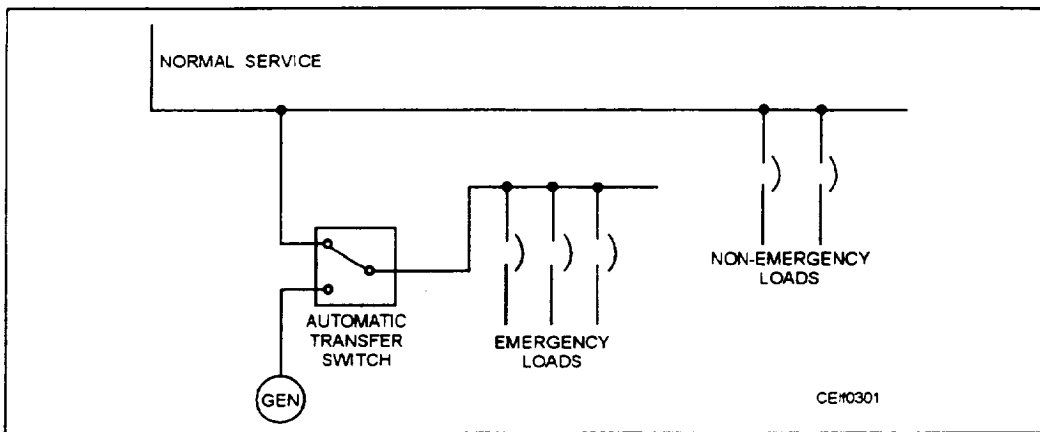

Figure 3-1.—Single-transfer switch.

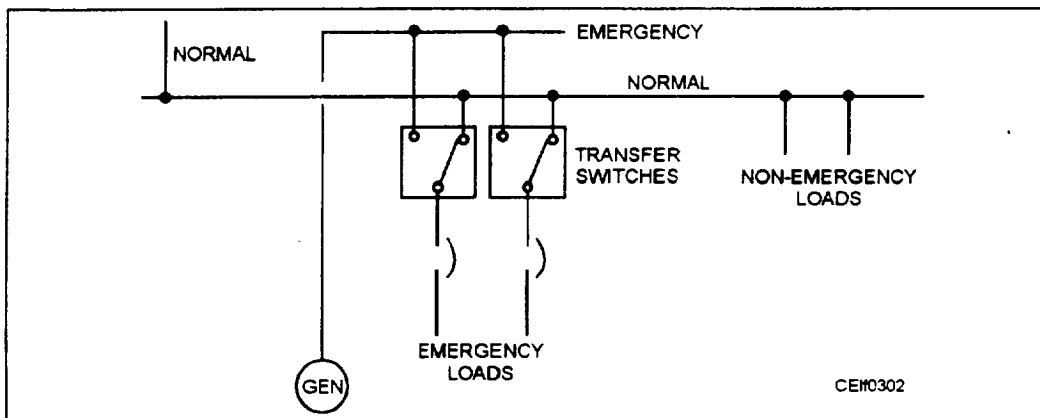

Figure 3-2.—Multiple-transfer switches.

The electrical loads to be supplied power, voltage, phase, frequency, and duty cycle requirements govern the selection of generating equipment. Probable load deviation, probable life of the installation, availability of fuels, and availability of skilled personnel are other important factors.

Electrical plants at advanced bases serve a varied load of lighting, heating, and power equipment, most of which demand power day and night. The annual load factor (the ratio of average power to peak power) of a well-operated active base should be 50 percent or more with a power factor (explained later in this chapter) of 80 percent or higher. If the load is more than a few hundred feet from the power source, a high-voltage distribution system may be required.

If several generators are to serve primary distribution systems, they should generate the same voltage to avoid the need for voltage transformation. The number of phases required by the load may differ from that produced by the generator. As loads usually can be divided and balanced between phases, most generators of appreciable size are wound for three-phase operation.

Power and Voltage Requirements

The selection of voltage is affected by the size, the character, and the distribution of the load; length, capacity, and type of transmission and distribution circuits; and size, location, and connection of generators. Practically all general-purpose lighting in the United States and at United States overseas bases is 120 volts. The lighting voltage may be obtained from a three-wire, 120/240-volt, single-phase circuit or a 120/208-volt, three-phase, four-wire circuit.

Small motors can be supplied by single-phase ac at normally 120 volts. Large three-phase, ac motors above 5 horsepower generally operate satisfactorily at any voltage between 200 and 240. The use of combined light and power circuits will be accomplished by the use of 240- or 208-volt systems.

Computation of the Load

As mentioned earlier in this chapter, there are various factors that must be taken into consideration in the selection of the required generating equipment. The following technical data will help you in computing the load.

Table 3-1.—Types of Portable Generators

	Alternating current					
Frequency			60-hertz			
Voltage	120		120/208		120/208 240/416	
Phase	1		1 & 3		3	
Wires	2		4*		4	
Fuel	G	D	G	D	G	D
kW Rating						
5	X		X	X		X
10			X	X		
15			X	X		
30				X		X
60				X		X
100				X		X
200						X

G—Gasoline driven. D—Diesel driven.
 *—Panel connections permit, at rated kW output: 120/208V
 3-phase 4-wire, 120V 3-phase 3-wire, 120V single-phase
 2-wire, 120/240V single-phase 3 wire.

Before any part of the system can be designed, the amount of power to be transmitted, or the electrical load, must be determined. Electrical loads are generally measured in terms of amperes, kilowatts, or kilovoltamperes. In general, electrical loads are seldom constant for any appreciable time, but fluctuate constantly. In calculating the electrical load, you must determine the connected load first. The connected load is the sum of the rated capacities of all electrical appliances, lamps, motors, and so on, connected to the wiring of the system. The maximum demand load is the greatest value of all connected loads that are in operation over a specified period of time. Knowledge of the maximum demand of groups of loads is of great importance: because it is the group maximum demand that determines the size of generators, conductors, and apparatus throughout the electrical system.

The ratio between the actual maximum demand and the connected load is called the DEMAND FACTOR. If a group of loads were all connected to the supply source and drew their rated loads at the same time, the demand factor would be 1.00. There are two main reasons why the demand factor is usually less than 1.00. First, all load devices are seldom in use at the same time and, even if they are, they will seldom reach maximum demand at the same time. Second, some load devices are usually slightly larger than the minimum size needed and normally draw less than their rated load. Since the maximum demand is one of the factors determining the size of conductors, it is important that the demand factor be established as closely as possible.

The demand factor varies considerably for different types of loads, services, and structures. The National Electrical Code[®], Article 220, provides the requirements for determining demand factors. Demand factors for some military structures are given in table 3-2.

Example: A machine shop has a total connected load of 50.3 kilowatts. The demand factor for this type of structure is taken at 0.70. The maximum demand is $50.3 \times 0.70 = 35.21$ kilowatts.

GENERATOR INSTALLATION

Generators are not permitted to be closer than 25 feet to a load; however, in setting up the generator, try to place the equipment near points of large demand to reduce the size of wire required: to hold the line losses to a minimum, and to afford adequate voltage control at the remote ends of the lines.

Moving the generator may be accomplished by lifting or pulling. The generator set comes equipped with a lifting sling usually stored in the skid on the side of the unit opposite the operator's control panel.

Site Selection

You should study a plot or chart of the area on which the individual buildings and facilities have been plotted. The site you select should be large enough to meet present and anticipated needs. Then select a location where there will be sufficient space on all sides for servicing and operation of the unit. It should be level, dry, and well drained. If this type of site is not available, place the generator set on planks, logs, or other material for a suitable base foundation.

Table 3-2.—Demand Factor

Structure	Demand Factor
Housing	0.9
Aircraft maintenance facilities	.7
Operation facilities	.8
Administrative facilities	.8
Shops	.7
Warehouses	.5
Medical facilities	.8
Theaters	.5
NAV aids	.5
Laundry, ice plants, and bakeries	1.0
All others	.9

Sheltering of Generators

Although advanced base portable generators are designed to be operated outdoors, prolonged exposure to wind, rain, and other adverse conditions will definitely shorten their lives. If the generators are to remain on the site for any extended period of time, they should be mounted on solid-concrete foundations and installed under some type of shelter.

Presently, there are no predrawn plans for shelters for a small advanced base generating station. The shelter will be an on-the-spot affair, the construction of which is determined by the equipment and material on hand plus your ingenuity and common sense.

Before a Builder can get started on the shelter, you will have to inform him of such things as the number of generators to be sheltered; the dimensions of the generators; the method of running the generator load cables from the generator to the distribution system outside the building; and the arrangement of the exhaust system, radiator discharge, and cooling air. Installation specifications are available in the manufacturer's instruction manual that accompanies each unit. Be sure to use them. Appropriate consultation with the Builder regarding these specifications may help minimize various installation and piping problems and costs.

The following hints and suggestions also will be helpful:

1. Ventilation is an important factor to consider when you are installing the units inside a building. Every internal combustion engine is a HEAT engine. Although heat does the work, excess amounts of heat must be removed if the engine is to function properly. Heat can be removed by setting the engine radiator grille near an opening in the wall and providing another opening directly opposite the unit. In this manner, cool air can be drawn in and the hot air directed outdoors. These openings can be shielded with adjustable louvers to prevent the entrance of rain, sand, or snow. In addition, when the engine is operating in extremely cold weather, the temperature in the room can be controlled by simply closing a portion of the discharge opening. Additional doors or windows should be provided in the shelter if the plants are installed in localities where the summer temperatures exceed 80°F at any time.

2. Working space is another consideration. Be sure to provide sufficient space around each unit for repairs or disassembly and for easy access to the generator control panels.

3. The carbon monoxide gas present in the exhaust of the engine is extremely poisonous. Under no circumstances should this gas be allowed to collect in a closed room; therefore, means have to be provided to discharge the engine exhaust to the outdoors. Exhaust can be vented by extending the exhaust pipe through the wall or roof of the building. Support the exhaust pipe and make certain that there is no obstruction and avoid right-angle bends, if possible. Also, whenever possible, arrange the exhaust system so that the piping slopes away from the engine. In this way, condensation will not drain back into the cylinders. If the exhaust pipe should have to be installed so that loops or traps are necessary, a drain cock should be placed at the lowest point of the system. All joints have to be perfectly tight; and where the exhaust pipe passes through the wall, you have to prevent the discharged gas from returning along the outside of the pipe back into the building. Exhaust piping inside the building has to be covered with insulation capable of withstanding a temperature of 1500°F.

After the generating units have been set in place and bolted down, Builders then can proceed to erect the building, using the necessary information provided by the CEs.

Generator Set Inspection

After setting up a portable generator, your crew must do some preliminary work before placing the generator in operation. First, they should make an overall visual inspection of the generator. Have them look for broken or loose electrical connections, bolts, and cap screws; and see that the **ground terminal wire (No. 6 AWG minimum) is properly connected to the ground rod/grounding system.** Check the technical manual furnished with the generator for wiring diagrams, voltage outputs, feeder connections, and prestart preparation. If you find any faults, you should correct them immediately.

Generator Connections

When you install a power plant that has a dual-voltage alternator unit, make certain that the stator coil leads are properly connected to produce the voltage required by the equipment.

Proper grounding is also a necessity for personnel safety and for prevention of unstable, fluctuating generator output.

INTERNAL LEADS.—The voltage changeover board permits reconnection of the generator phase

windings to give all specified output voltages. One end of each coil of each phase winding runs from the generator through an instrumentation and a static exciter current transformer to the reconnection panel. This routing assures current sensing in each phase regardless of voltage connection at the reconnection board assembly. The changeover board assembly is equipped with a voltage change board to facilitate conversion to 120/208 or 240/416 generator output voltage. Positioning of the voltage change board connects two coils of each phase in series or in parallel. In parallel, the output is 120/208; in series, the output is 240/416 volts ac. The terminals on the changeover board assembly for connection to the generator loads are numbered according to the particular coil end of each phase of the generator to ensure proper connections.

Remember that you are responsible for the proper operation of the generating unit; therefore, proceed with caution on any reconnection job. Study the wiring diagrams of the plant and follow the manufacturer's instructions to the letter. Before you start the plant up and close the circuit breaker, double-check all connections.

GROUNDING.—It is imperative that you solidly ground all electrical generators operating at 600 volts or less. The ground can be, in order of preference, an underground metallic water piping system, a driven metal rod, or a buried metal plate. A ground rod has to have a minimum diameter of 5/8 inch if solid and 3/4 inch if pipe, and it has to be driven to a minimum of 8 feet. A ground plate has to be a minimum of 2 square feet and be buried at a minimum depth of 2 1/2 feet. For the ground lead, use No. 6 AWG copper wire and bolt or clamp it to the rod, plate, or piping system. Connect the other end of the ground lead to the generator set ground stud.

The National Electrical Code[®] states that a single electrode consisting of a rod, pipe, or plate that does not have a resistance to ground of 25 ohms or less will be augmented by additional electrodes. Where multiple rod, pipe, or plate electrodes are installed to meet the requirements, they are required to be not less than 6 feet apart.

It is recommended that you perform an earth resistance test before you connect the generator to ground. This test will determine the number of ground rods required to meet the requirements, or it may be necessary to construct a ground grid.

Feeder Cable Connections

While the electric generator is being installed and serviced, a part of your crew can connect it to the load. Essentially, this connection consists of running wire or cable from the generator to the load. At the load end, the cable is connected to a distribution terminal. At the generator end, the cable is connected either to the output terminals of a main circuit breaker or a load terminal board. Before the wires are run and connections are made, it will be up to you to do the following:

1. Determine the correct size of wire or cable to use.
2. Decide whether the wire or cable will be buried, carried overhead on poles, or run in conduit.
3. Check the generator lead connections of the plant to see that they are arranged for the proper voltage output.

The information contained in the following paragraphs will help you in these tasks.

CABLE SELECTION.—If the wrong size conductor is used in the load cable, various troubles may occur. If the conductor is too small to carry the current demanded by the load, it will heat up and possibly cause a fire or an open circuit. Even though the conductor is large enough to carry the load current safely, its length might result in a lumped resistance that produces an excessive voltage drop. An excessive voltage drop results in a reduced voltage at the load end. This voltage drop should not exceed 3 percent for power loads, 3 percent for lighting loads, or 6 percent for combined power and lighting loads.

Select a feeder conductor capable of carrying 150 per cent of rated generator amperes to eliminate overloading and voltage drop problems. Refer to the National Electrical Code® tables for conductor ampacities. These tables are 310-16, 310-17, 310-18, and 310-19. You also should refer to the notes to ampacity tables following table 310-19.

CABLE INSTALLATION.—The load cable may be installed overhead or underground. In an emergency installation, time is the important factor. It may be necessary to use trees, pilings, 4 by 4s, or other temporary line supports to complete the installation. Such measures are temporary; eventually, you will have to erect poles and string the wire or bury it underground. If the installation is near an airfield, it may be necessary to place the wires underground at the

beginning. Wire placed underground should be direct-burial, rubber-jacketed cable; otherwise, it will not last long.

Direct burying of cable for permanent installation calls for a few simple precautions to ensure uninterrupted service. They are as follows:

1. Dig the trench deep enough so that the cable can be buried at least 18 inches (24 inches in traffic areas and under roadways) below the surface of the ground to prevent disturbance of the cable by frost or subsequent surface digging.
2. After laying the cable and before backfilling, cover it with soil free from stones, rocks, and so forth. That will prevent the cable from being damaged in the event the surrounding soil is disturbed by flooding or frost heaving.

GENERATING PLANT OPERATIONS

When you are in charge of a generating station, you will be responsible for scheduling around-the-clock watches to ensure a continuous and adequate amount of electrical power. Depending on the number of operating personnel available, the watches are evenly divided over the 24-hour period. A common practice is to schedule 6-hour watches, or they may be stretched to 8-hour watches without working undue hardship on the part of the crew members. Watches exceeding 8 hours, however, should be avoided unless emergency conditions dictate their use.

The duties assigned to the personnel on generator watches can be grouped into three main categories: (1) operating the equipment, (2) maintaining the equipment, and (3) keeping the daily operating log. Operating and maintaining the generating equipment will be covered in the succeeding sections of this chapter, so for the present you can concentrate on the importance of the third duty of the station operator—keeping a daily operating log.

The number of operating hours are recorded in the generating station log. The log serves as a basis for determining when a particular piece of electrical equipment is ready for inspection and maintenance. The station log can be used in conjunction with previous logs to spot gradual changes in equipment condition that ordinarily are difficult to detect in day-to-day operation. It is particularly important that you impress upon your watch standers the necessity for taking accurate readings at periods specified by local operating conditions.

Ensure that watch standers keep their spaces clean and orderly. Impress on them the importance of keeping tools and auxiliary equipment in their proper places when not in use. Store clean waste and oily waste in separate containers. **OILY WASTE CONTAINERS ARE REQUIRED TO BE KEPT COVERED.** Care given to the station floor will be governed by its composition. Generally, it should be swept down each watch. Any oil or grease that is tracked around the floor should be removed at once.

Plant Equipment

Setting up a power generator is only one phase of your job. After the plant is set up and ready to go, you will be expected to supervise the activities of the operating personnel of the generating station. In this respect, your supervision should be directed toward one ultimate goal—to maintain a continuous and adequate flow of electrical power to meet the demand. That can be accomplished if you have a thorough knowledge of how to operate and maintain the equipment and a complete understanding of the station's electrical systems as a whole. Obviously, a thorough knowledge of how to operate and maintain the specific equipment found in the generating station to which you are assigned cannot be covered here; however, general information will be given. It will be up to you to supplement this information with the specific instructions given in the manufacturers's instruction manuals furnished with each piece of equipment.

Similarly, familiarity with the station's electrical system as a whole can be gained only by a study of information relating specifically to that installation. This information can be found to some extent in the manufacturer's instruction manuals. You can obtain the greater part of it from the station's electrical plans and wiring diagrams. Remember, however, to supplement your study of the electrical plans and diagrams with an actual study of the generating station's system. In that way, the generators, switchgear, cables, and other electrical equipment are not merely symbols on a plan but physical objects whose location is definitely known and whose functions and relation to the rest of the system are thoroughly understood.

Single Plant Operation

Connecting an electric plant to a de-energized bus involves two general phases: (1) starting the diesel engine and bringing it up to rated speed under control of the governor and (2) operating the switchboard

controls to bring the power of the generator onto the bus.

Different manufacturers of generating plants require the operator to perform a multitude of steps before starting the prime mover; for example, if a diesel engine is started by compressed air, the operator would have to align the compressed air system. This alignment would not be necessary if the engine is of the electric-start type. It is important that you, as the plant supervisor, establish a prestart checklist for each generating plant. The prestart checklist provides a methodical procedure for confirming the operational configuration of the generating plant; following this procedure assures that all systems and controls are properly aligned for operation.

The checklist should include, but is not limited to, the following:

1. Align ventilation louvers.
2. Check lube oil, fuel oil, and cooling water levels.
3. Ensure battery bank is fully charged.
4. Align electrical breakers and switches for proper operation of auxiliary equipment.
5. Check control panel and engine controls.
6. Select the proper operating position for the following controls for single plant operation.
 - Voltage regulator switch to UNIT or SINGLE position.
 - Governor switch to ISOCHRONOUS or SINGLE position.

NOTE: Adjust hydraulic governor droop position to 0.

- Voltage regulator control switch to AUTO position.

The prestart checklist should be completed in sequence before you attempt to start the generating plant.

Start the generating plant and adjust the engine rpm to synchronous speed. Adjust the voltage regulator to obtain the correct operating voltage. Set the synchronizing switch to the ON position and close the main circuit breaker. Adjust the frequency to 60 hertz with the governor control switch. Perform hourly operational checks to detect abnormal conditions and to ensure the generating set is operating at the correct voltage and frequency.

Parallel Plant Operation

If the load of a single generator becomes so large that its rating is exceeded, you should add another generator in parallel to increase the power available for the generating station. Before two ac generators can be paralleled, the following conditions have to be fulfilled:

1. Their terminal voltages have to be equal.
2. Their frequencies have to be equal.
3. Their voltages have to be in phase.

When two generators are operating so that the requirements are satisfied, they are said to be in synchronism. The operation of getting the machines into synchronism is called synchronizing.

Generating plants may be operated in parallel on an isolated bus (two or more generators supplying camp or base load) or on an infinite bus (one or more generators paralleled to a utility grid).

One of the primary considerations in paralleling generator sets is achieving the proper division of load. That can be accomplished by providing the governor of the generator with speed droop. That would result in a regulation of the system. The relationship of REGULATION to LOAD DIVISION is best explained by referring to a speed versus load curve of the governor. For simplicity, we will refer to the normal speed as 100 percent speed and full load as 100 percent load. In the controlled system, we will be concerned with two types of governor operations: isochronous and speed droop.

The operation of the isochronous governor (0 percent speed droop) can be explained by comparing speed versus load, as shown in figure 3-3. If the governor were set to maintain the speed represented by line A and connected to an increasing isolated load, the speed would remain constant. The isochronous governor will maintain the desired output frequency, regardless of load changes if the capacity of the engine is not exceeded.

The speed-droop governor (100 percent speed droop) has a similar set of curves, but they are slanted, as shown in figure 3-4. If a speed-droop governor were connected to an increasing isolated load, the speed would drop (line A, fig. 3-4) until the maximum engine capacity is reached.

Now let's imagine that we connect the speed-droop governor (slave machine) to a utility bus so large that our engine cannot change the bus frequency (an

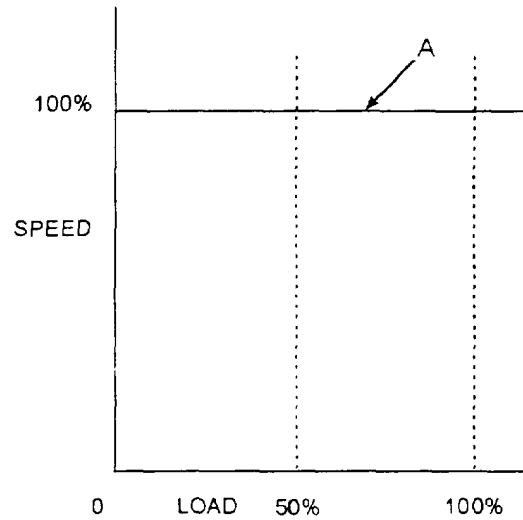
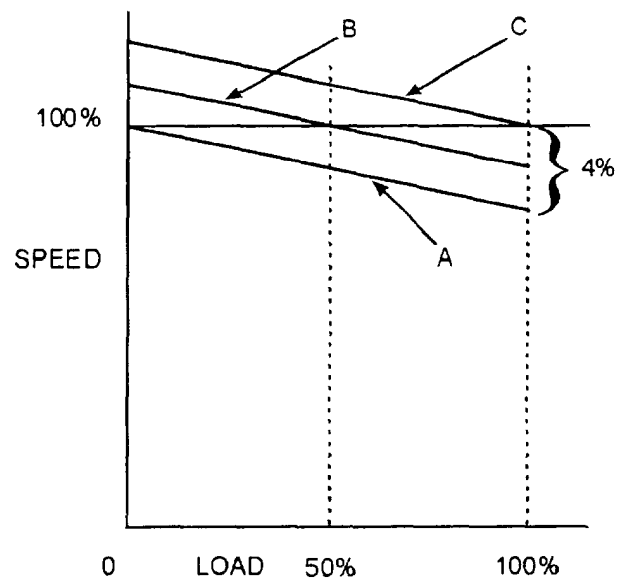

Figure 3-3.—Isochronous governor curve.



CEI10304

Figure 3-4.—Speed-droop governor curve.

infinite bus). Remember that the speed of the engine is no longer determined by the speed setting but by the frequency of the infinite bus. In this case, if we should change the speed setting, we would cause a change in load, not in speed. To parallel the generator set, we are required to have a speed setting on line A (fig. 3-4), at which the no-load speed is equal to the bus frequency. Once the set is paralleled, if we increase the speed setting to line B, we do not change the speed, but we pick up approximately a half-load. Another increase in speed setting to line C will fully load the engine. If the generator set is fully loaded and the main breaker is

opened, the no-load speed would be 4 percent above synchronous speed. This governor would be defined as having 4 percent speed droop.

Paralleling an isochronous governor to an infinite bus would be impractical because any difference in speed setting would cause the generator load to change constantly. A speed setting slightly higher than the bus frequency would cause the engine to go to full-load position. Similarly, if the speed setting were slightly below synchronous speed, the engine would go to no-load position.

Setting speed droop on hydraulic governors is accomplished by adjusting the speed-droop knob located on the governor body. Setting the knob to position No. 5 does not mean 5 percent droop. Each of the settings on the knob represents a percentage of the total governor droop. If the governor has a maximum of 4 percent droop, the No. 5 position would be 50 percent of 4 percent droop. Setting speed droops on solid-state electronic governors is accomplished by placing the UNIT-PARALLEL switch in the PARALLEL position. The governor speed droop is factory set, and no further adjustments are necessary.

ISOLATED BUS OPERATION.—In the following discussion, assume that one generator, called the master machine, is operating and that a second generator, called the slave machine, is being synchronized to the master machine. Governor controls on the master generator should be set to the ISOCHRONOUS or UNIT position. The governor setting on the slave generator must be set to the PARALLEL position.

NOTE: The hydraulic governor droop setting is an approximate value. Setting the knob to position No. 5 will allow you to parallel and load the generator set. Minor adjustments may be necessary to prevent load swings after the unit is operational.

When you are paralleling in the droop mode with other generator sets, the governor of only one set may be in the isochronous position; all others are in the droop position. The isochronous set (usually the largest capacity set) controls system frequency and immediately responds to system load changes. The droop generator sets carry only the load placed on them by the setting of their individual speed controls. Both voltage regulators should be set for parallel and automatic operation.

The slave machine is brought up to the desired frequency by operating the governor controls. It is preferable to have the frequency of the slave machine

slightly higher than that of the master machine to assure that the slave machine will assume a small amount of load when the main circuit breaker is closed. Adjust the voltage controls on the slave machine until the voltage is identical to that of the master machine. Thus two of the requirements for synchronizing have been met: ‘frequencies are equal and terminal voltages are equal.

There are several methods to check generator phase sequence. Some generator sets are equipped with phase sequence indicator lights and a selector switch labeled “GEN” and “BUS.” Set the PHASE SEQUENCE SELECTOR SWITCH in the BUS position, and the “1-2-3” phase sequence indicating light should light. (The same light must light in either GEN or BUS position.) If “3-2-1” phase sequence is indicated, the slave machine has to be shut down, the load cables isolated, and two of the load cables interchanged at their connection to the load terminals.

Another method to verify correct phase sequence is by using the synchronizing lights. When the synchronizing switch is turned on, the synchronizing lights will start blinking. If the synchronizing lights blink on simultaneously and off simultaneously, the voltage sequences of the two machines are in phase. The frequency at which the synchronizing lights blink on and off together indicates the different frequency output between the two machines. Raise or lower the speed of the slave machine until the lights blink on together and off together at the slowest possible rate. If the synchronizing lights are alternately blinking (one on while the other is off), the voltage sequence of the two machines is not in phase. Correct this condition by interchanging any two of the three load cables connected to the slave machine.

Some of the portable generators being placed in the NMCB Table of Allowances (TOA) are equipped with a permissive paralleling relay. This relay, wired into the main breaker control circuit, prevents the operator from paralleling the generator until all three conditions have been met.

Now that all three paralleling requirements have been met, the slave machine can be paralleled and loaded.

If a synchroscope is used, adjust the frequency of the slave machine until the synchroscope pointer rotates clockwise slowly through the ZERO position (twelve o’clock). Close the main circuit breaker just before the pointer passes through the ZERO position. To parallel using synchronizing lights, wait until the

lamps are dark; then, while the lamps are still dark, close the main circuit breaker and turn off the synchronizing switch.

After the main breaker has been closed, check and adjust the load distribution by adjusting the governor speed control. Maintain approximately one-half load on the master machine by manually adding or removing the load from the slave machine(s). The master machine will absorb all load changes and maintain correct frequency unless it becomes overloaded or until its load is reduced to zero.

The operator also must ensure that all generating sets operate at approximately the same power factor (PF). PF is a ratio, or percentage, relationship between watts (true power) of a load and the product of volts and amperes (apparent power) necessary to supply the load. PF is usually expressed as a percentage of 100. Inductive reactance in a circuit lowers the PF by causing the current to lag behind the voltage. Low PFs can be corrected by adding capacitor banks to the circuit.

Since the inductive reactance cannot be changed at this point, the voltage control rheostat has to be adjusted on each generator to share the reactive load. This adjustment has a direct impact on the generator current, thus reducing the possibility of overheating the generator windings.

PF adjustment was not discussed in the “Single Plant Operation” section because a single generator has to supply any true power and/or reactive load that may be in the circuit. The single generator must supply the correct voltage and frequency regardless of the power factor.

INFINITE BUS OPERATION.—Paralleling generator sets to an infinite bus is similar to the isolated bus procedure with the exception that all sets will be slave machines. The infinite bus establishes the grid frequency; therefore, the governor of each slave machine has to have speed droop to prevent constant load changes.

Emergency Shutdown

In the event of engine overspeed, high jacket water temperature, or low lubricating oil pressure, the engine may shut down automatically and disconnect from the main load by tripping the main circuit breaker. In addition, an indicator may light or an alarm may sound to indicate the cause of shutdown. After an emergency shutdown and before the engine is returned to

operation, the cause of shutdown should be investigated and corrected.

NOTE: It is important to check the safety controls at regular intervals to determine that they are in good working order.

Basic Operating Precautions

The order that you post in the station for the guidance of the watch standers should include a general list of operating rules and electrical safety precautions. **BE SURE YOU ENFORCE THEM!**

The important operating rules are relatively few and simple. They are as follows:

1. Watch the switchboard instruments. They show how the system is operating; and they reveal overloads, improper division of kilowatt load or reactive current between generators operating in parallel, and other abnormal operating conditions.
2. Keep the frequency and voltage at their correct values. A variation from either will affect, to some extent at least, the operation of the electrical equipment of the base. This result is especially true of such equipment as teletypewriters or electrical clocks. An electrical clock and an accurate mechanical clock should be installed together at the generating station so that the operators can keep the generators on frequency.
3. Use good judgment when reclosing circuit breakers after they have tripped automatically; for example, generally the cause should be investigated if the circuit breaker trips immediately after the first reclosure. However, reclosing of the breaker the second time may be warranted if immediate restoration of power is necessary and there was no excessive interrupting disturbance when the breaker tripped. It should be kept in mind, however, that repeated closing and tripping may damage the circuit breaker as well as the overload vault area, thus increasing the repair or replacement work.
4. Do not start a plant unless all its switches and breakers are open and all external resistance is in the exciter field circuit.
5. Do not operate generators at continuous overload. Record the magnitude and duration of the overload in the log; record any unusual conditions or temperatures observed.
6. Do not continue to operate a machine in which there is vibration until the cause is found and corrected. Record the cause in the log.

The electrical safety precautions that should be observed by the station personnel are as follows:

1. Treat every circuit, including those as low as 24 volts, as a potential source of danger.
2. Except in cases of emergency, never allow work on an energized circuit. Take every precaution to insulate the person performing the work from ground. That may be done by covering any adjacent grounded metal with insulating rubber blankets. In addition, provide ample illumination, cover working metal tools with insulating rubber, station men at appropriate circuit breakers or switches so that the switchboard can be de-energized immediately in case of emergency, and make sure all personnel are qualified to render first aid (including CPR) for electric shock.

POWER PLANT MAINTENANCE

Inspection and servicing procedures covered in this chapter are rather general. In most cases, they can be applied to any electrical power generator that you install. You realize, of course, that there are other special installation details that pertain only to the particular generator you happen to be working on. Because of the many different types of generators, certain instructions are applicable only to specific types of generators; therefore, you should consult the manufacturer's instruction manuals for these details.

Power plant maintenance can be divided into two general categories: operator maintenance and preventive maintenance.

Operator Maintenance

Operator maintenance includes the hourly, daily, and weekly maintenance requirements recommended

in the manufacturer's literature. Some operator maintenance and routine checks include the following:

- Bring oil level to the high mark on the dip stick.
- Free movement of ventilation louvers.
- Drain water and sediment from strainers and filters.
- Maintain level of coolant.
- Check radiator and coolant hoses for leaks.
- Check battery electrolyte level.
- Check all switches for proper operation.
- Drain water from fuel tank.
- Fill fuel tank as required with appropriate diesel fuel.
- Check fuel tank for leaks.

Log all operator maintenance in the operations log book when it is completed.

Preventive Maintenance

Preventive maintenance includes the monthly, quarterly, semiannual, and annual maintenance checks recommended in the manufacturer's literature. The maintenance supervisor is responsible for establishing a maintenance schedule to ensure the preventive maintenance is performed. A maintenance log book should be established for each generator plant and all maintenance checks recorded. The operation log book should be reviewed periodically to ensure that all preventive maintenance recommended by engine operating hours is scheduled; for example, the schedule of engine lube oil and filter replacement is normally based on hours of operation.

CHAPTER 4

ELECTRICAL DISTRIBUTION

INTRODUCTION

As a Construction Electrician second class, you may have to supervise the installation, maintenance, and repair of overhead primary and secondary power distribution systems. This chapter will provide the necessary information to enable you to calculate electrical loads and perform fundamental tasks in the selection, by size and type, of distribution equipment. When you perform the above-mentioned tasks, remember, your primary goal should be the safety of your troops.

A power distribution system includes all parts of an electrical system between the power source and the customer's service entrance. The power source may be either a local generating plant or a high-voltage transmission line feeding a substation that reduces the high voltage to a voltage suitable for local distribution. At most advance bases, the source of power will be generators connected directly to the load.

DISTRIBUTION SYSTEMS CONFIGURATION

The configurations of four distribution systems are defined in the following paragraphs. These four distribution systems — radial, loop (ring), network, and primary selective — are briefly described. For additional information, review the *Electric Power Distribution Systems Operations*, NAVFAC MO-201.

RADIAL DISTRIBUTION SYSTEM

A representative schematic of a radial distribution system is shown in figure 4-1. You should note that the independent feeders branch out to several distribution centers without intermediate connections between feeders.

The most frequently used system is the radial distribution system because it is the simplest and least expensive system to build. Operation and expansion are simple. It is not as reliable as most systems unless quality components are used. The fault or loss of a cable, primary supply, or transformer will result in an outage on all loads served by the feeder. Furthermore, electrical service is interrupted when any piece of

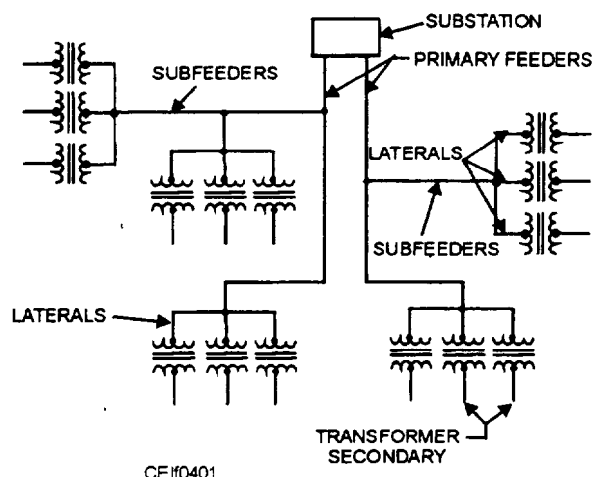

Figure 4-1.—Radial distribution system.

service equipment must be de-energized to perform routine maintenance and service.

Service on this type of feeder can be improved by installing automatic circuit breakers that will reclose the service at predetermined intervals. If the fault continues after a predetermined number of closures, the breaker will lock out until the fault is cleared and service is restored by hand reset.

LOOP/RING DISTRIBUTION SYSTEM

The loop, or ring, system of distribution starts at the substation and is connected to or encircles an area serving one or more distribution transformers or load centers. The conductor of the system returns to the same substation.

The loop system (fig. 4-2) is more expensive to build than the radial type, but it is more reliable. It may be justified in an area where continuity of service is of considerable importance, for example, a medical center.

In the loop system, circuit breakers sectionalize the loop on both sides of each distribution transformer connected to the loop. The two primary feeder breakers and the sectionalizing breakers associated with the loop feeder are ordinarily controlled by pilot wire relaying or directional overcurrent relays. Pilot wire relaying is used when there are too many secondary substations to obtain selective timing with directional overcurrent relays.

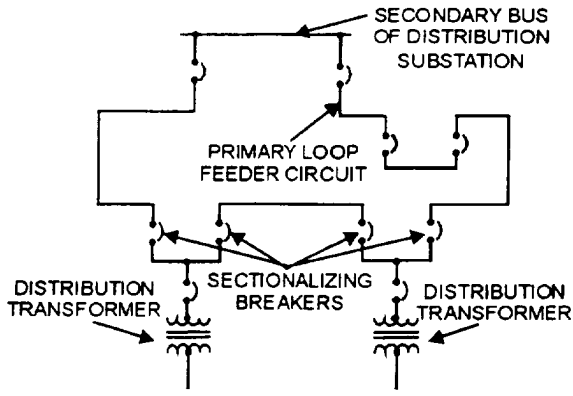

CEI#0402

Figure 4-2.—Loop, or ring, distribution system.

A fault in the primary loop is cleared by the breakers in the loop nearest the fault, and power is supplied the other way around the loop without interruption to most of the connected loads. Because the load points can be supplied from two or more directions, it is possible to remove any section of the loop from service for maintenance without causing an outage at other load points. If a fault occurs in a section adjacent to the distribution substation, the entire load may have to be fed from one side of the loop until repairs are made. Sufficient conductor capacity must be provided in the loop to permit operation without excessive voltage drop or overheating of the feeder when either side of the loop is out of service. If a fault

occurs in the distribution transformer, it is cleared by the breaker in the primary leads; and the loop remains intact.

NETWORK DISTRIBUTION SYSTEM

The network and radial systems differ with respect to the transformer secondaries. In a network system (fig. 4-3) transformer secondaries are paralleled; in a radial system, they are not.

The network is the most flexible type of primary system; it provides the best service reliability to the distribution transformers or load center, particularly when the system is supplied from two or more distribution substations. Power can flow from any substation to any distribution transformer or load center in the network system. The network system is more flexible with regard to load growth than the radial or loop system and is adaptable to any rate of load growth. Service readily can be extended to additional points of usage with relatively small amounts of new construction. The network system, however, requires large quantities of equipment and extensive relaying; therefore, it is more expensive than the radial system. From the standpoint of economy, the network system is suitable only in heavy-load-density areas where the load center units range from 1,000 to 4,000 kilovoltamperes (kVA).

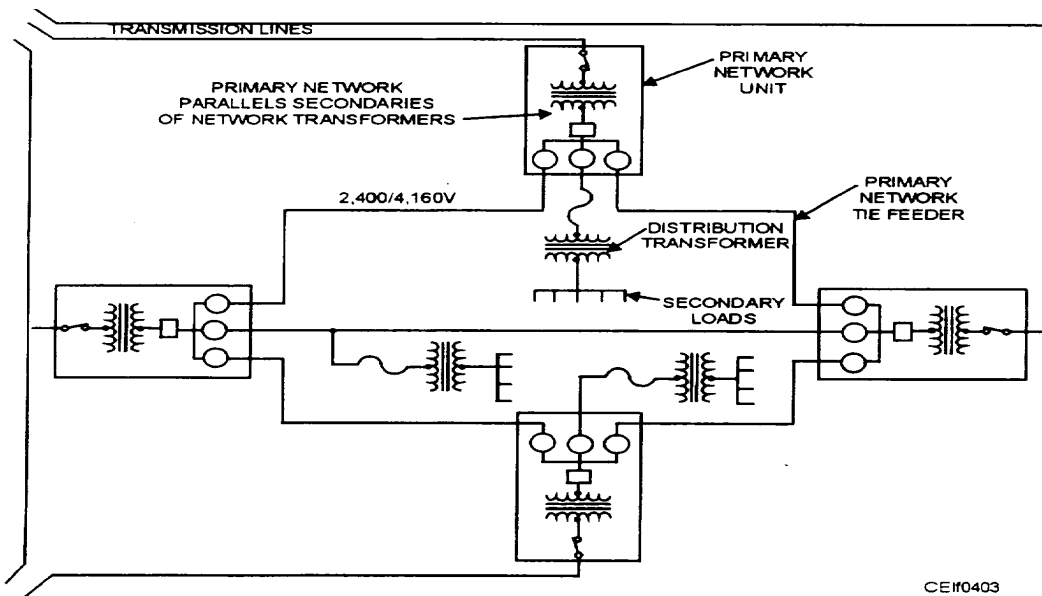

CEI#0403

Figure 4-3.—Network distribution system.

The transformers of a secondary network distribution system are connected in parallel through a special type of circuit breaker, called a network protector, to a secondary bus. Radial secondary feeders are tapped from the secondary bus to supply loads. A more complex network is a system in which the low-voltage circuits are interconnected in the form of a grid or mesh.

If a primary feeder fails or a fault occurs on a primary feeder or distribution transformer, the other transformers start to feed back through the network protector on the faulted circuit. This reverse power causes the network protector to open and disconnect the faulty supply circuit from the secondary bus. The network protector operates so fast that there is minimal exposure of secondary equipment to the associated voltage drop.

PRIMARY SELECTIVE SYSTEM

In some instances, a higher degree of reliability can be attained with a primary selective system. Protection against loss of a primary supply can be gained through the use of a primary selective system (fig. 4-4). Each unit substation is connected to two separate primary feeders through switching equipment to provide a normal and an alternate source. When the normal source feeder is out of service for maintenance or a fault, the distribution transformer is switched,

either manually or automatically, to the alternate source. An interruption will occur until the load is transferred to the alternate source. Cost is somewhat higher than the radial system because primary cable and switchgear are duplicated.

In laying out a distribution system for a base, you should divide the base into a number of sections. These sections should be chosen so that the load in each section is close to one of the distribution centers. You take this action to keep the length of the mains as short as possible and to keep the voltage drop low between the distribution and the loads. The distribution or load centers should be located as near as possible to the electrical load center.

OVERHEAD CONSIDERATIONS

In the construction and maintenance of Navy power distributions systems, you should be aware of the overhead distribution pole locations and the types of overhead distribution equipment used. An excellent source of information on distribution systems is *The Lineman's and Cableman's Handbook*.

POLE LOCATIONS

Your decision on the location of poles is limited because either you will be replacing existing poles or installing additional poles according to NAVFAC

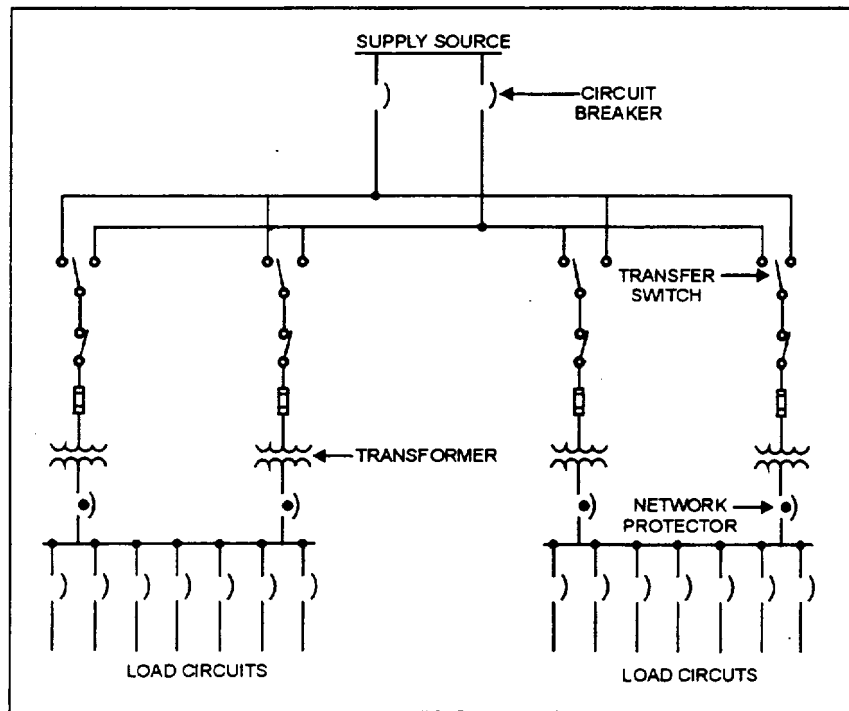

CE10404

Figure 4-4.—Primary selective distribution system.

drawings and specifications. You may be asked to submit information (fact-gathering package) on a new power distribution addition to the base. If so, the following recommended actions need to be considered:

- Install utility poles in the same location, especially on upgrade projects.
- Install power distribution systems underground whenever possible.
- Conduct a survey using a map to chart the territory where the distribution lines are to be routed (for large areas, aerial photography is faster and more accurate).
- Ensure that the survey map is large enough to clearly show all buildings, roads, streams, hills, ridges, railroads, bridges, and any existing power and communications lines.
- Select the straightest and shortest route whenever possible.
- Route the new distribution system near or in the general direction of future load demands.
- Make the distribution system readily accessible for construction, inspection, and maintenance by paralleling them to existing streets and highways.
- Avoid crossing hills, ridges, and swamp areas whenever possible to reduce the possibility of lightning and wind damage. These areas also increase costs because additional materials are needed and maintenance will be more difficult.
- Coordinate with communication companies to prevent the induction of interference with their existing lines.
- Select a route that is away from residential areas and does not damage the environment.
- Keep major traffic routes free from primary, circuits, especially in nonindustrial areas.
- Keep distribution lines on the same side of the road whenever possible.
- Avoid blocking driveways, entrances, exits, and fire escapes when installing branch lines or guys.
- Locate poles 2 feet from the curb.
- Finally, plan for future street-lighting circuits.

EQUIPMENT

Many different types and makes of overhead distribution equipment are in use today. This chapter will cover some of the standard equipment you will

install and maintain, such as poles, transformers, capacitors, interrupting and protective devices.

Poles

Utility poles that support electrical lines must be designed to support the conductors, insulators, and shield conductors in a manner that provides adequate electrical clearances. A safe clearance must be maintained when the conductor temperature is elevated as a result of a large amount of current flowing in a circuit and also when the conductors are ice coated or strong winds are blowing.

The three most common types of poles that you will be working with are wood, reinforced concrete, and steel. Other types of poles in use are as follows: aluminum, fiber glass, and polysil. As a Seabee assigned to either a PWC or a battalion, you will be responsible for ordering, installing, and maintaining the utility poles.

Power lines supported by wood-pole structures are generally considered to be the most economical. In the United States, the southern yellow pine, western red cedar, and the Douglas fir are the most commonly used species of tree. All wooden poles are given a preservative treatment (normally pressure treated) to prevent deterioration. The service life of the utility pole can be doubled by preservative treatment. Many of the older poles now in use were treated with creosote.

CAUTION

Creosote is a toxic compound that irritates the skin and sometimes causes blistering. It is also carcinogenic and is being phased out because of groundwater contamination problems. Used creosote contaminated poles may not be burned and must be disposed of in EPA approved landfills. You should use extra care when working around poles treated with creosote, avoid prolonged skin contact, and wash thoroughly after handling. Clothing contaminated with creosote should be laundered separately from family clothing.

Creosote oil, pentachlorophenol, and chromated copper arsenates have been used to provide a preservation treatment of wood poles. Newer poles are now treated with less toxic chemicals and, therefore, are safer to work with and also easier to climb (because the treatment softens the wood). They are environmentally acceptable because they do not contain materials that are toxic to mammals.

Wooden utility poles are classified by the length, circumference at the top of the pole, and the circumference measured 6 feet from the bottom of the pole. Pole sizes begin at 25 feet and are increased in 5-foot increments up to 90 feet in length. The pole top circumference increases 2 inches for every class of pole. There are 10 classes of wooden poles numbered from 1 to 10. Class 1 is the smallest and class 10 is the biggest. The American National Standards Institute's publication entitled *Specifications and Dimensions for Wood Poles* (ANSI 05.1) provides technical data for wood utility poles.

Distribution Transformers

For long-distance transmission, a voltage higher than normally generated is required. A step-up transformer is used to produce the high voltage. Most electrical equipment in the Navy uses 120/208 volts. The primary voltage distributed on Navy shore installations, however, is usually 2,400/4,160 and 13,800 volts. A distribution transformer (step-down) is required to reduce the high-primary voltage to the utilization voltage of 120/208 volts. The various types of transformer installations are discussed later in this chapter. Regardless of the type of installation or arrangement, transformers must be protected by fused cutouts or circuit breakers; and lightning arresters should be installed between the high-voltage line and the fused cutouts.

Three general types of single-phase distribution transformers are in use today. The conventional type requires a lightning arrester and fuse cutout on the primary-phase conductor feeding the transformer. The self-protected (SP) type has a built-in lightning protector; the completely self-protected (CSP) type has the lightning arrester and current-overload devices connected to the transformer and requires no separate protective devices. You should review Module 2, Navy Electricity and Electronics Training Series (NAVEDTRA 172-02-00-91) for more information on transformer theory.

In primary and secondary windings construction, the change in voltage in a transformer depends on the number of turns of wire in the coils. The high-voltage winding is composed of many turns of relatively small wire, insulated to withstand the voltage applied to the winding. The secondary winding is composed of a few turns of heavy copper wire, large enough to carry high current at a low voltage. Figure 4-5 shows a single-phase transformer with secondary windings connected in series and parallel.

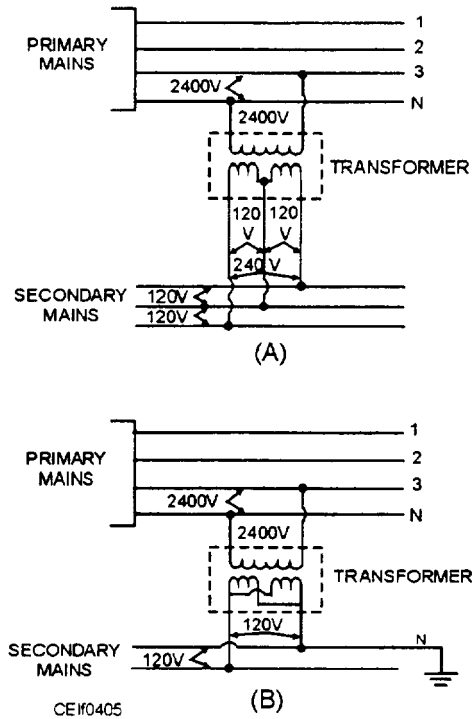

Figure 4-5.—Single-phase transformer with secondary windings connected in series and parallel.

In a distribution transformer, a secondary coil is wound on each leg of the laminated iron core, and the primary coil is wound over the secondary coils. The primary leads pass through a steel tank and are insulated from the tank by porcelain bushings. The secondary leads are connected to studs on a terminal block. Copper straps on the secondary terminal block permit connecting the two secondary coils in series or in parallel. From the terminal block, three secondary leads pass through porcelain bushings to the outside of the tank. An oil-level line inside the tank marks the level to which the tank is filled with transformer oil.

Several methods of cooling transformers are in use today, such as self-air cooling, air-blast cooling, liquid-immersed self cooling, and liquid-immersed water cooling. Self-air cooling types of transformers are simply cooled by surrounding air at atmospheric pressure; the heat is removed by natural convection (normal dissipation of heat by cooling). The self-air cooling transformer is called the dry type of transformer.

The air-blast cooling transformer has the core and windings encased in a metal enclosure through which air is circulated by a blower. This type is used for large power transformers with ratings from 12,000 to 15,000 kVA.

The liquid-immersed self-cooling transformer has its coils and core completely immersed in transformer

oil. In large transformers, the tanks have external tubes or external radiators through which the oil circulates by natural convection caused by the differences in oil temperature.

The liquid-immersed water-cooling transformer is sometimes used where a plentiful supply of cool water is available. In this type, a coil of copper or brass pipe is installed near the top of the tank in the cooling oil. Water is circulated through this coil and carries away the heat from the oil as it rises in the tank.

Insulating liquids have high-insulating qualities and serve two purposes: first, they insulate the coil, and second, they help dissipate the heat generated by the resistance of the windings and eddy currents in the iron core. If this heat were not removed, the transformer would operate at excessively high temperatures, which, in turn, would damage or destroy the insulation on the coils.

Two common types of insulating liquids are mineral oil and Askarel[®]. Mineral oil is a nontoxic insulating liquid. It is used in different types of high-voltage electrical equipment, such as circuit breakers, switches, and transformers. Mineral oil must be kept in an airtight container, or else sludge will form. This sludge will settle in the bottom of the tank and slow the natural transfer of heat. Also the longer mineral oil is left exposed to air, the greater the loss of insulation properties.

Askarel[®] is a synthetic, nonflammable insulating liquid. It has other trade names, such as Pyranol[®], Inerteen[®], Chlorexirol[®], and Asbestol[®]. This liquid must be handled with care because of its toxic chemical properties. Askarel[®] is used in special transformers for applications where flammable liquids must be avoided.

Askarel[®] may have an irritating effect upon the skin, eyes, nose, and lips. It also may irritate skin abrasions or tender areas between the fingers. Askarel[®] may contain polychlorinated biphenyls (PCBs): a toxic, carcinogenic oily liquid. Transformers tested and found to be contaminated with PCBs should have labels on the outside of the transformer warning of this hazard.

WARNING

- If assigned to work on a transformer known to be contaminated with PCBs, see your supervisor for a Material Safety Data Sheet (MSDS) for hazards and

precautions. Personal protective equipment, such as impermeable gloves and chemical splash goggles, are mandatory.

- Avoid prolonged skin contact and wash thoroughly after use.
- Avoid breathing vapors.
- When removing transformer oil, wear respiratory protection. If you discover PCB transformer oil spilled on soil, immediately notify your supervisor who must notify environmental authorities and summons a trained hazardous material spill clean-up team.

To protect yourself when handling Askarel[®], wear impermeable gloves. Also wear splashproof goggles. Whenever liquid comes in contact with the skin, wash it thoroughly with warm water and soap.

Ensure that the work space is properly ventilated before working on transformers containing Askarel[®].

Avoid breathing Askarel[®] vapors. Wear an approved organic vapor cartridge respirator when vapors are present. When removing Askarel[®] oil which is contaminated with PCBs, air respirators may be necessary.

If a blueprint of a particular transformer installation is available to you, your job will be comparatively easy. All construction and electrical specifications will be worked out for you beforehand, and all you have to do is convert this information into a finished product. However, in some instances, a blueprint will not be available. Then it will be up to you to determine the location and size of the transformer and install it according to the latest specifications. You should be familiar with the rules and requirements of the most current electrical codes. Be sure to carefully study any applicable code requirements before installing a transformer.

Transformers are mounted on poles in various ways, such as suspended on a bracket bolted to the pole, suspended from a crossarm with brackets, or set on a platform mounted on an H-frame.

Single-phase transformers are usually hung with a through-bolt type of bracket or a cross-arm type of bracket. Figure 4-6 shows a single transformer hung with cross-arm brackets. Figure 4-7 shows a bank of three transformers of 25 kVA capacity hung the same way.

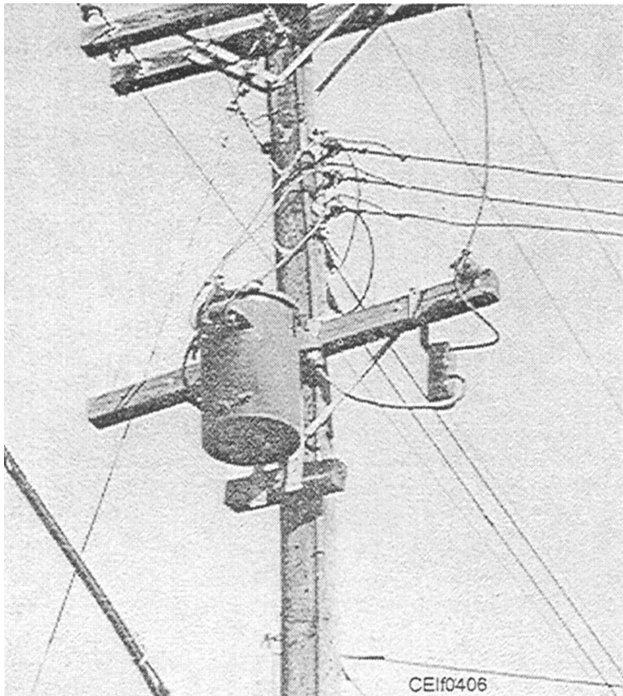

Figure 4-6.—Single transformer hung with crossarm brackets.

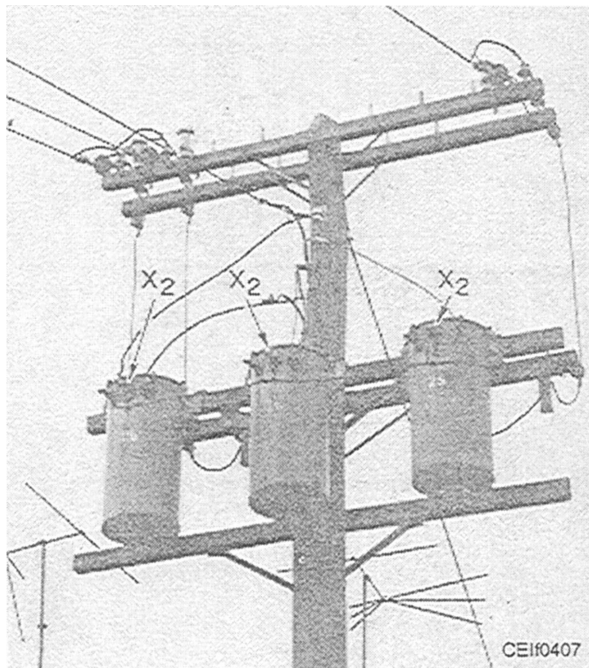

Figure 4-7.—Three-phase bank of transformers hung on a crossarm.

Formerly, all banks of three transformers were hung with crossarm brackets or mounted on a platform between two poles. Because of improved materials, however, transformer capacities have been enlarged without increasing their size and weight. This improvement means that banks of three large transformers can now be hung on a pole with a through-bolt type of suspension, as shown in figure 4-8.

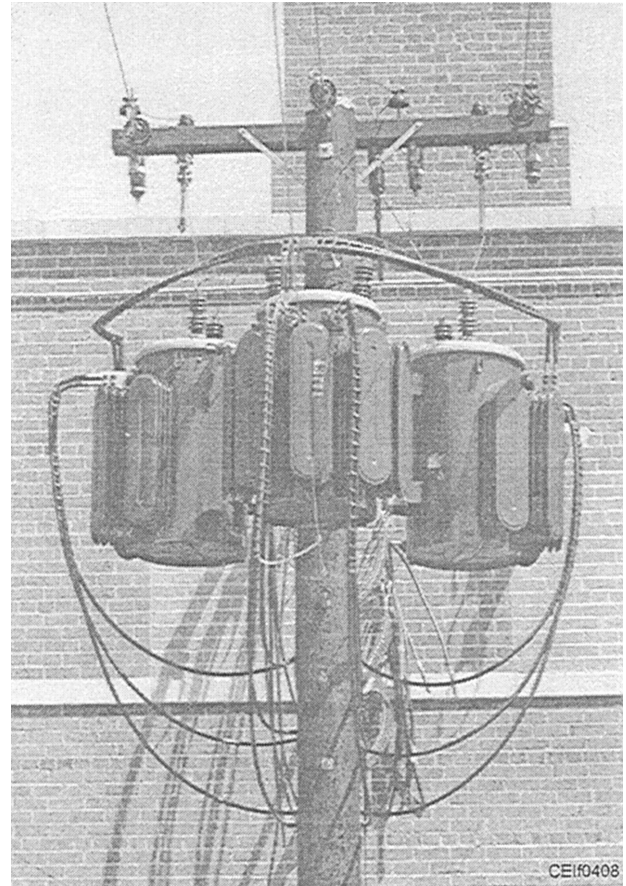

Figure 4-8.—Three 37.5 kVA transformers mounted with through-bolt type of brackets.

The old method of mounting transformers on a platform required an extra pole and the added cost of building the platform. This method is still used when installing large transformers and in special job applications. Figure 4-9 shows the platform method of mounting a bank of three single-phase, 25 kVA transformers-Y-connected to obtain single-phase and three-phase power.

Grounding the distribution system helps to prevent accidents to personnel and damage to property in the event of insulation breakdown, accidental shorting of high- and low-voltage lines, or a lightning strike.

If a high-voltage line is accidentally shorted with a low-voltage line, the current will flow through the secondary coil of the transformer to the secondary ground that will then cause the primary protective device to open the circuit. In this case, the primary protective device functions as the substation circuit breaker. An accidental shorting of the primary and secondary windings in the transformer will cause the primary fuse to open.

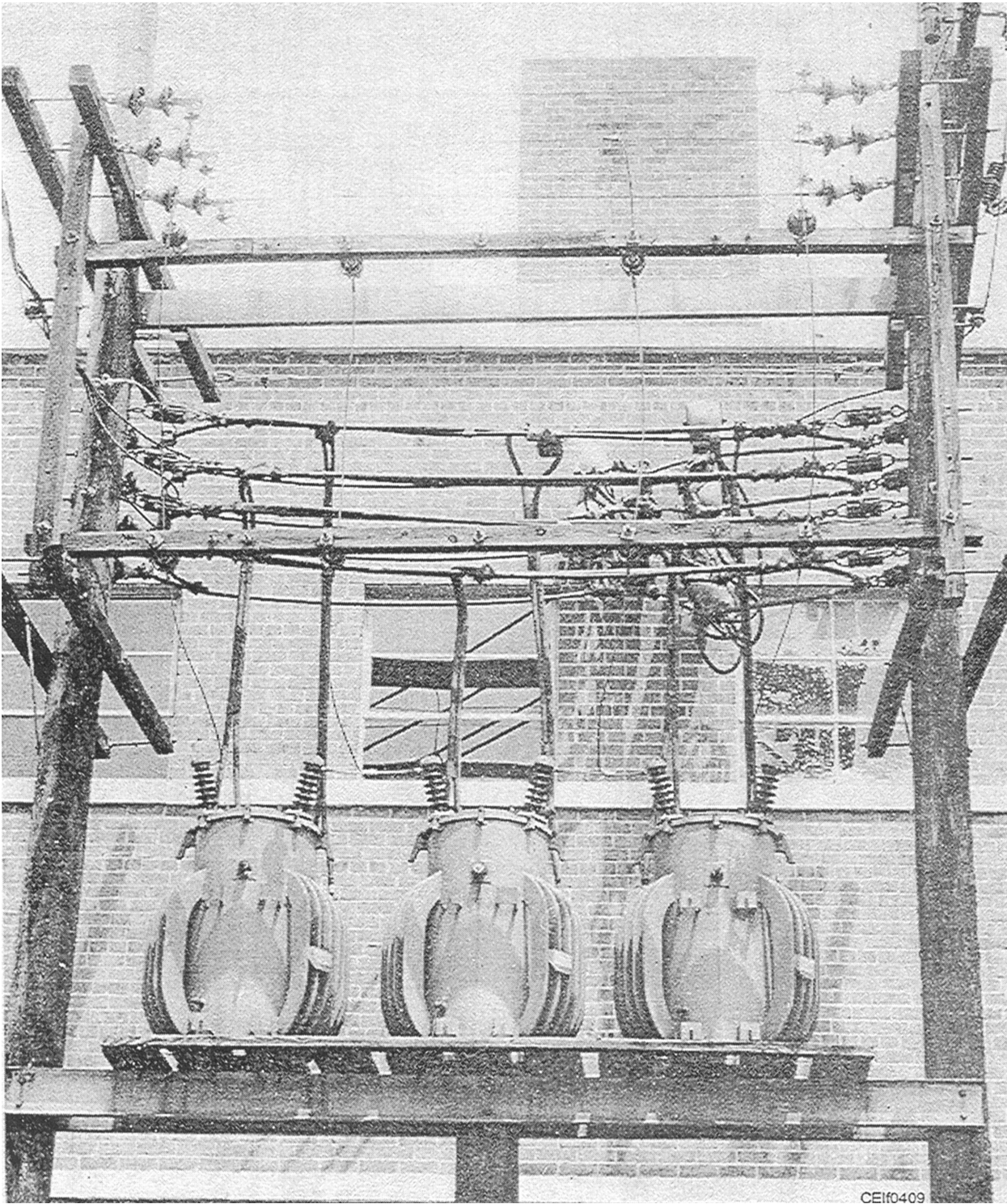

Figure 4-9.—Three-phase 25 kVA transformers mounted on an H-frame platform.

If there are no ground connections, the primary voltage will be impressed upon the secondary conductors, which are usually, insulated for 600 volts, and considerable damage to the equipment will occur.

Great danger will exist for everyone touching any electrical equipment at this time.

Ground resistance must not exceed 25 ohms to ground. This resistance can be measured with various

portable ground-testing instruments, such as a megger. One procedure for measuring ground resistance with a megger is shown in figure 4-10.

If the ground resistance is too high, it may be lowered by one of the following methods:

1. Drive additional rods, spacing them 6 feet apart, and then connect them in parallel.
2. Use larger rods where low resistance soils are too far below the surface to be reached by ordinary rods.

When you are connecting transformers in parallel or in a three-phase bank, it is important to know the polarity of the transformer terminals or leads. In the manufacturing of transformers, the ends of the windings are connected to the leads extending out through the case. The internal connection determines the direction of current flow in the secondary terminal with respect to the corresponding primary terminal. The current may flow in the same direction or in the opposite direction. When the current flows in the primary and secondary windings in the same direction, the polarity of the transformer is said to be subtractive; and when the current flows in the opposite directions, the polarity is said to be additive.

Polarity may be further explained as follows: imagine a single-phase transformer having two

high-voltage and three low-voltage external terminals. Connect one high-voltage terminal to the adjacent low-voltage terminal, and apply a test voltage across the two high-voltage terminals. If the voltage across the unconnected high-voltage and low-voltage terminals is less than the test voltage, the polarity is subtractive; if it is greater than the test voltage, the polarity is additive. This test is shown in figure 4-11.

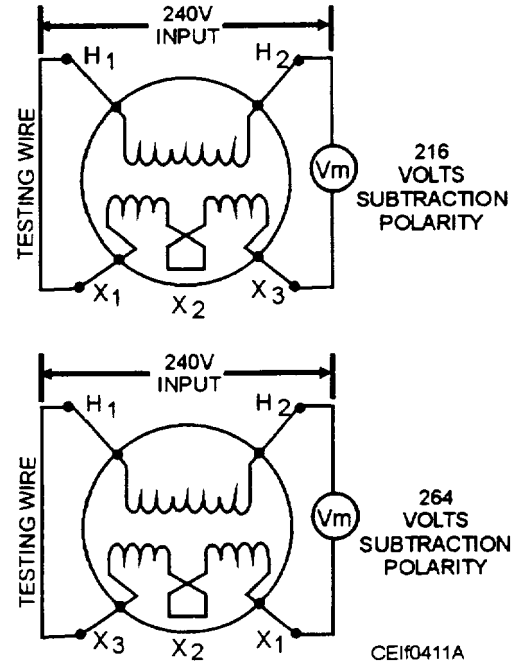

Figure 4-11.—Polarity tests.

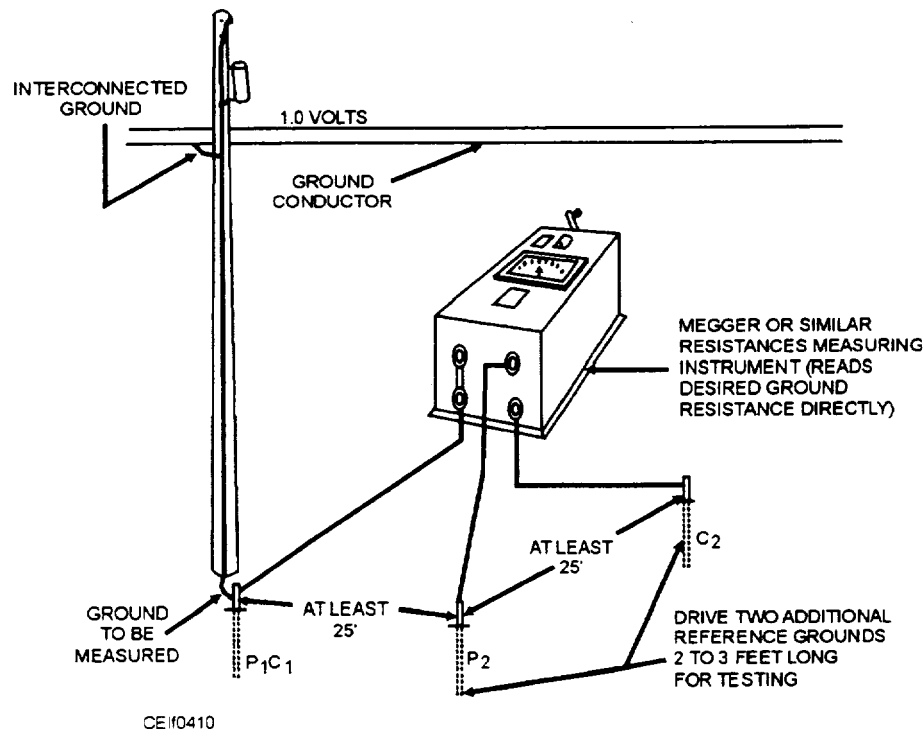

Figure 4-10.—Measuring ground resistance where the ground wire is interconnected with the ground distribution neutral connector.

It is apparent that when the voltage indicated on the voltmeter is greater than the impressed voltage, it must be the sum of the primary and the secondary voltages; and the direction of the two windings must be opposite, as shown in figure 4-12. Likewise, when the voltage read on the voltmeter is less than the impressed voltage, the voltage must be the difference of the primary and secondary voltages, as shown in figure 4-13. When the terminal markings are arranged in the same numerical order, H1H2 and X1X2 or H2H1 and X2X1, on each side of the transformer, the polarity of each winding is the same (subtractive). If either is in reverse order, H2H1 and X1X2 or H1H2 and X2X1, their polarities are opposite (additive). The nameplate of a transformer should always indicate the polarity of the transformer.

Additive polarity is standard for all single-phase distribution transformers 200 kVA and below having high-voltage ratings of 9,000 volts and below.

Subtractive polarity is standard for all single-phase distribution transformers above 200 kVA irrespective of the voltage rating.

Subtractive polarity is standard for all single-phase transformers 200 kVA and below having high-voltage ratings above 9,000 volts.

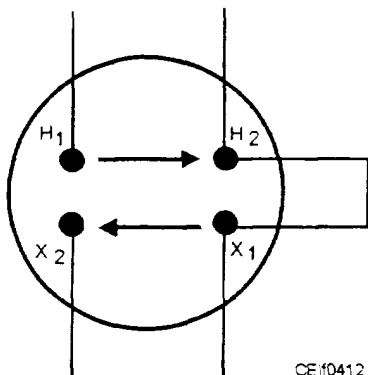

Figure 4-12.—Polarity markings and directions of voltages when polarity is additive.

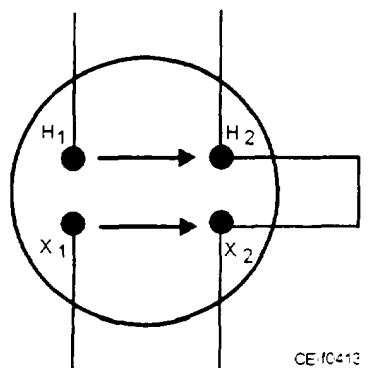

Figure 4-13.—Polarity markings and directions of voltages when polarity is subtractive.

Standard low-voltage terminal designations are shown in figure 4-14.

CAUTION

When you are making such tests, voltage must not be applied across the secondary side of the transformer because the primary voltage would then be equal to the applied secondary voltage multiplied by the transformer turns ratio. This voltage would be dangerously high to personnel and would damage the voltmeter.

Some important transformer installation rules are listed below.

1. One or more transformers may be hung on a single pole if the weight does not exceed the safe

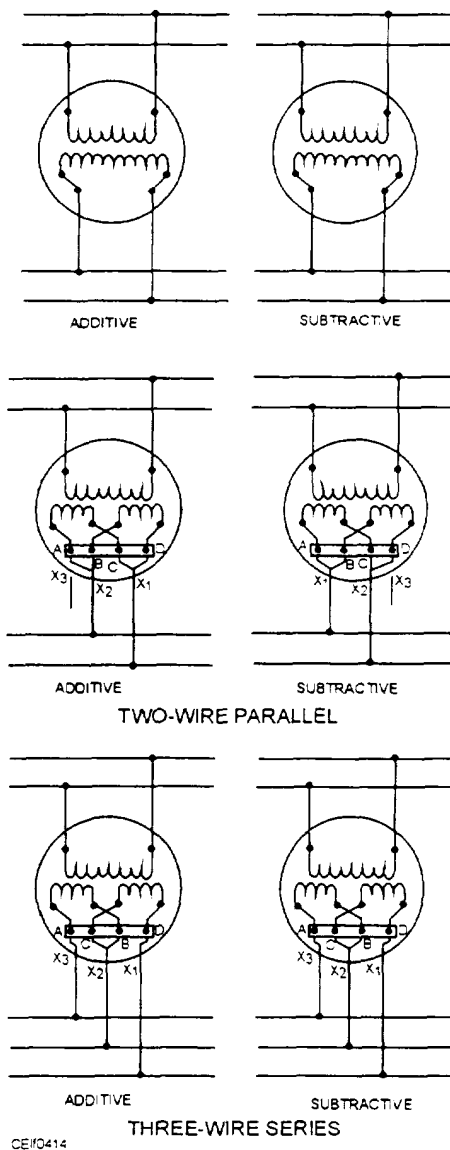

Figure 4-14.—Standard connections for low-voltage distribution transformers.

strength of the pole or the crossarms and bolts supporting them.

2. When more than one transformer is installed on crossarms, the weight should be distributed equally on the two sides of the pole.

3. Single-phase distribution transformers of 100 kVA or smaller are usually placed above the secondary mains if conditions permit. Those larger than 100 kVA are usually platform or pad mounted.

4. Lightning arresters and fused cutouts have to be installed on the primary side of all distribution transformers except the self-protected type.

5. Ground wires are required to be covered with plastic or wood molding to a point 8 feet above the base of the pole.

What is involved in the determination of the transformer size? Let's suppose you are given the job of installing a single-phase transformer in a certain area of the base. This area contains 10 barracks that receive power from a 2,400-volt overhead primary main. The electrical equipment in the barracks consists of single-phase lights or motors operating at either 110 or 220 volts. A three-wire overhead secondary main distributes the secondary voltage alongside the barracks. Service leads complete the connection between the secondary main and each building.

The first thing you should do is make a rough drawing of the area. When you are finished, it should look like figure 4-15. The location of each pole, as well

as the barracks, is noted. Lines representing the service leads are drawn between the pole and the building.

Your next step is to determine the total connected load of each service. It sounds complicated, but what it actually amounts to is summing up the power required by the lights and motors in each barracks. This power demand is noted in each square representing a barrack (fig. 4-15).

Next, figure out the kVA load per pole. In this particular example, each pole services two barracks; therefore, the kVA load of a pole will be the sum of the total connected loads of the two barracks served by that pole.

Now, calculate the total maximum connected load on the transformer. As you can see from figure 4-15, the total connected load is the sum of the kVA loads per pole. It amounts to 35.05 kVA. This amount of 35.05 kVA represents the amount of power that the transformer would have to supply if all the lights and motors were consuming power at the same time. Although that possibility exists, the time interval would be small compared to the length of time that only a portion of the total load would be on. Therefore, it is necessary to calculate only the maximum demand load and then use this figure as a basis for determining transformer size.

An approximation of the maximum demand load can be computed by multiplying the total maximum connected load by the demand factor listed in table 4-1. In this example, the maximum demand is 35.05 times

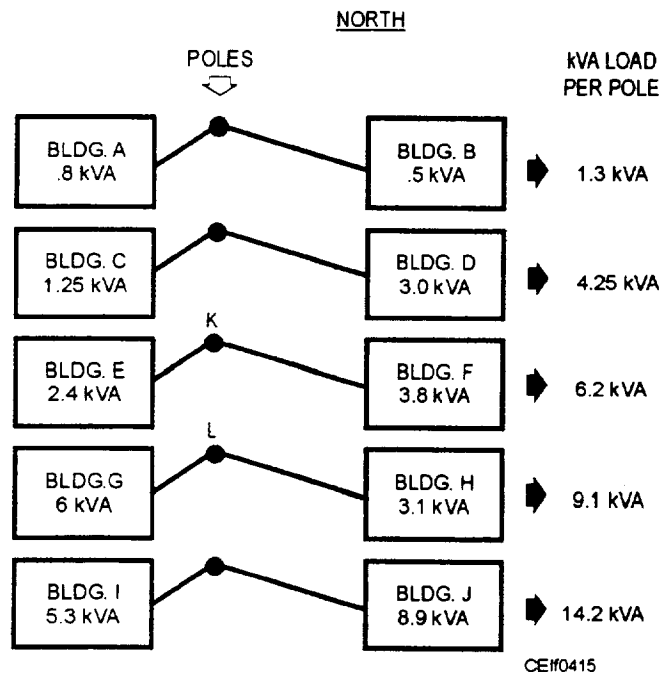

Figure 4-15.—Transformer size calculations.

0.9 which equals 31.545 kVA. The transformer capacity to meet this demand will be 37.5 kVA. The next largest standard size transformer is 50 kVA, much too large for this demand load, and the next smaller size is too small. However, if the computed total maximum load was 25.85 kVA times your demand factor, this would give you 23.26 kVA; therefore, you would need a 25 kVA transformer instead of the 37.5 kVA transformer.

Your next problem is to determine the most suitable location for the transformer. That does not mean finding the strongest pole but finding the pole that is nearest to the electrical center of the area.

The electrical center is the point where a balance is obtained between the total kVA spans to the north and south of the location of the transformer. The kVA span is the product of the number of spans times the kVA load of the pole.

To begin with, assume that you are going to place the transformer on pole K (fig. 4-15). Then figure the total kVA spans to the north and south of this location. A chart will simplify your calculation.

kVA Spans North of Pole K	kVA Spans South of Pole K
$1 \times 4.25 = 4.25$	$1 \times 9.1 = 9.1$
$2 \times 1.3 = 2.6$	$2 \times 14.2 = 28.4$
6.85	37.5
Total kVA spans north of pole K = 6.85	Total kVA spans south of pole K = 37.5

You can see that if you placed the transformer on pole K, it would be at an imbalanced electrical center; that is, it would be too far away from the heaviest loads. So pick another pole. This time choose pole L and make another chart.

kVA Spans North of Pole L	kVA Spans South of Pole L
$1 \times 6.2 = 6.2$	$1 \times 14.2 = 14.2$
$2 \times 4.25 = 8.5$	—
$3 \times 1.3 = 3.9$	14.2
18.6	Total kVA spans south of pole L = 14.2
Total kVA spans north of pole L = 18.6	

Pole L is nearest to the electrical center of the area. That is the pole on which you will mount the transformer.

Table 4-1.—Demand Factor

Structure	Demand Factor
Housing	0.9
Aircraft maintenance facilities	.7
Operation facilities	.8
Administrative facilities	.8
Shops	.7
Warehouses	.5
Medical facilities	.8
Theaters	3
NAV aids	.5
Laundry, ice plants, and bakeries	1.0
All others	.9

Single-phase distribution transformers are manufactured with one or two primary bushings. The single-primary-bushing transformers can be used only on grounded wye systems if they are properly connected. Figure 4-16 schematically shows the connections of a single-phase transformer to a three-phase 2,400-volt three-wire ungrounded delta primary voltage system to obtain 120-volt single-phase two-wire secondary service. The connections for similar systems operating at other primary distribution voltages such as 4,800, 7,200, 13,200, and 34,400 would be identical.

Figure 4-17 shows the proper connections for a single-phase transformer to a three-phase three-wire

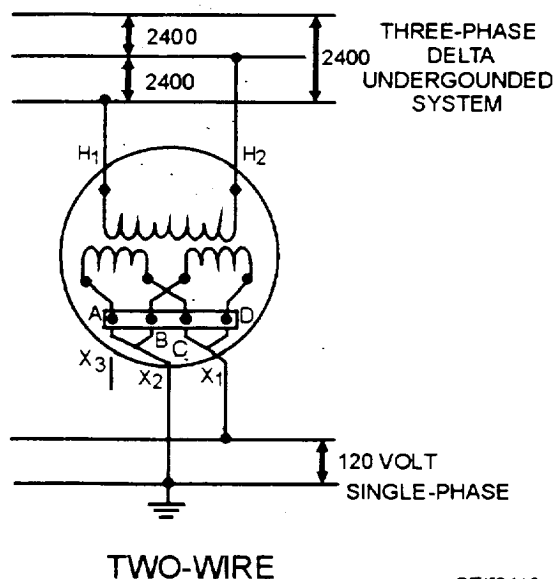

Figure 4-16.—Single-phase transformer connection for 120-volt two-wire secondary service. Transformer secondary coils are connected in parallel.

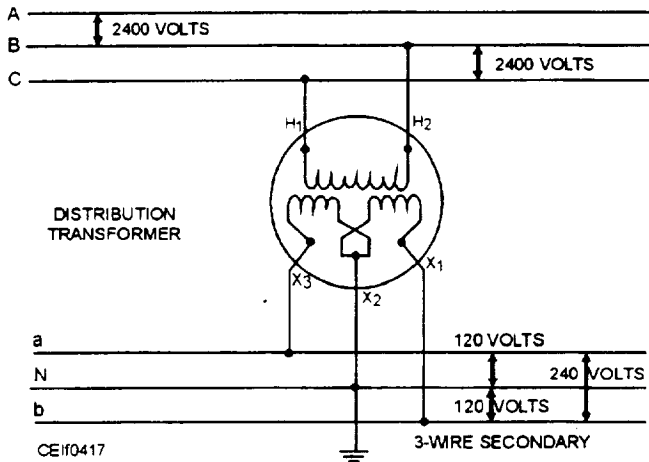

Figure 4-17.—Single-phase transformer connected to give 120/240-volt three-wire single-phase service. Transformer secondary coils are connected in series.

ungrounded delta primary voltage system to obtain 120/240-volt single-phase three-wire service. Normally the wire connected to the center low-voltage bushing will be connected to ground. Grounding the wire connecting to the center bushing limits the voltage aboveground to 120 volts, even though the wires connecting to the outside secondary bushings have 240 volts between them.

Figure 4-18 schematically shows the single-phase distribution transformer connections to a three-phase four-wire wye grounded neutral primary system rated 4,160Y/2,400 volts to obtain 120/240-volt single-phase secondary service. The three-phase four-wire wye grounded neutral system has voltage between phases equal to the phase or line to neutral voltage multiplied by 1.73. In figure 4-18, the primary system

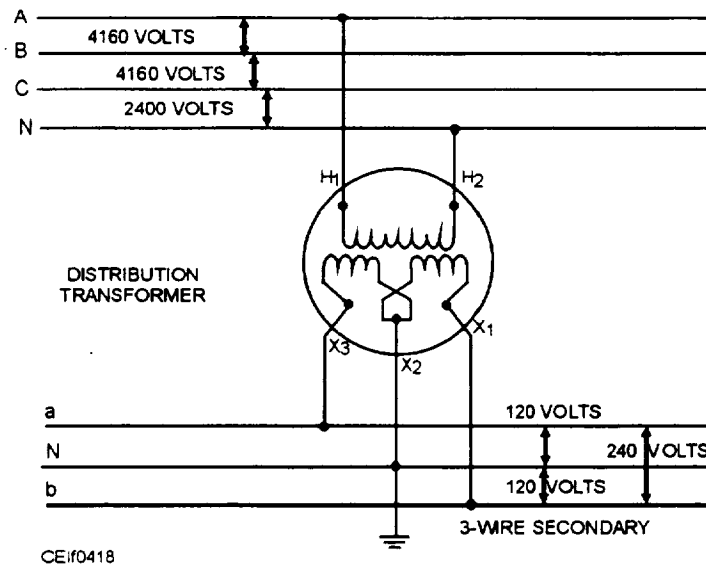

Figure 4-18.—Single-phase transformer connected to provide 120/240-volt three-wire single-phase service. Primary winding is connected to neutral or ground.

line to neutral voltage is 2,400 volts, and the voltage between phases is 1.73 times 2,400, or 4,160 volts. This system is designated as a 4,160Y/2,400-volt system. Other standard three-phase four-wire wye grounded neutral primary system voltages are 8,320Y/4,800, 12,470Y/7,200, 13,200Y/7,620, and 13,800Y/7,970.

The transformer connections to obtain 120, 120/240-volt secondary service are normally completed inside the tank of the transformer (fig. 4-19). The

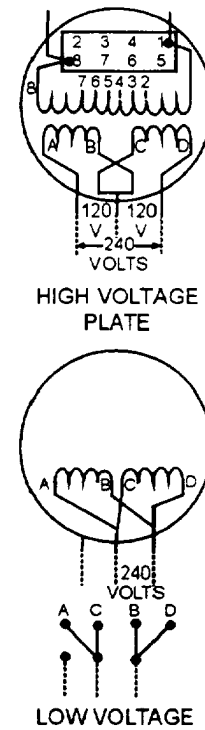

Figure 4-19.—Shows connections for 120/240-volt three-wire, 240-volt three-wire, and 120-volt two-wire services.

transformer nameplate provides information necessary to complete connections. The voltages should be measured when the transformer is energized to ensure that the connections are correct before the load is connected to the transformer.

Single-phase distribution transformers can be connected to obtain three-phase secondary service (fig. 4-20). There are four normal connections: the delta-delta (Δ/Δ), the wye-wye (Y/Y), the delta-wye (Δ/Y), and the wye-delta (Y/Δ). Figure 4-21 shows the proper connections for three single-phase distribution transformers connected to a three-phase three-wire ungrounded delta primary-voltage system to obtain three-phase three-wire delta secondary service. The illustration is for a 2,400-volt primary system and voltages would be connected the same. Single-phase transformers with secondary windings constructed for voltage of 240/480 should be used to obtain 480-volt three-phase secondary service.

Figure 4-22 shows the proper connections for three single-phase distribution transformers connected to a three-phase four-wire grounded neutral wye primary-voltage system to obtain 208Y/120- or 480Y/277-volt

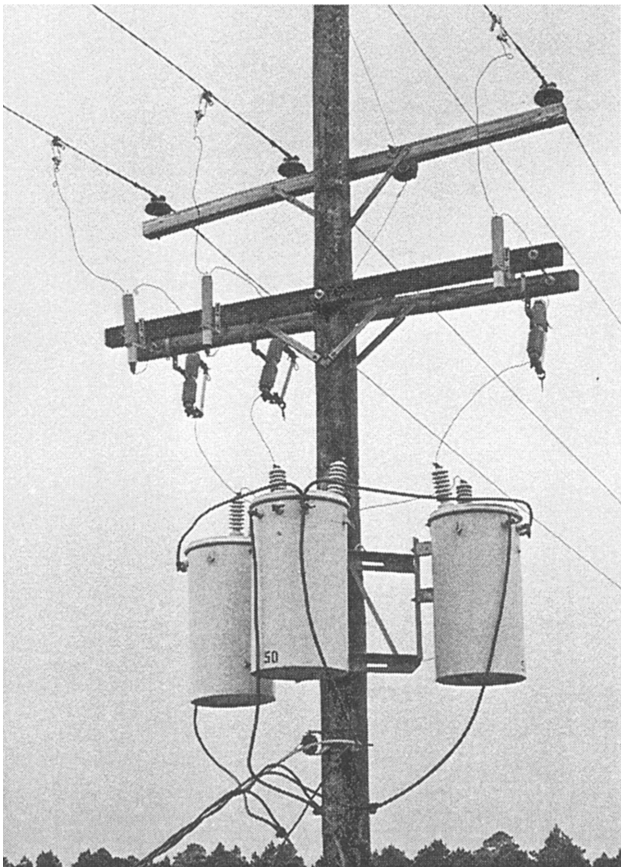

Figure 4-20.—Cluster-mounted bank of transformers.

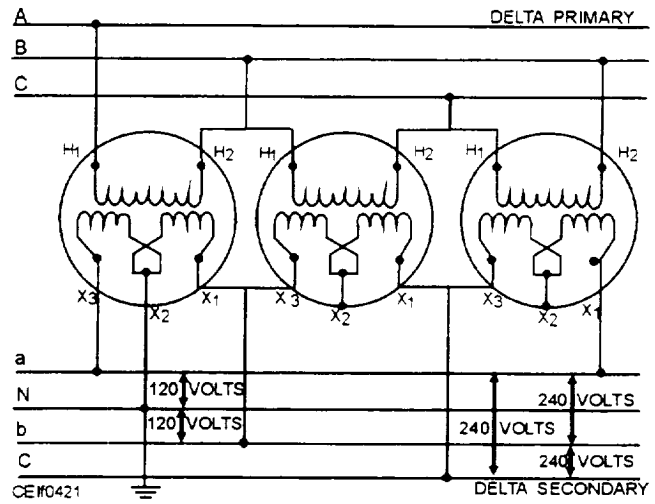

Figure 4-21.—Three single-phase distribution transformers connected delta-delta.

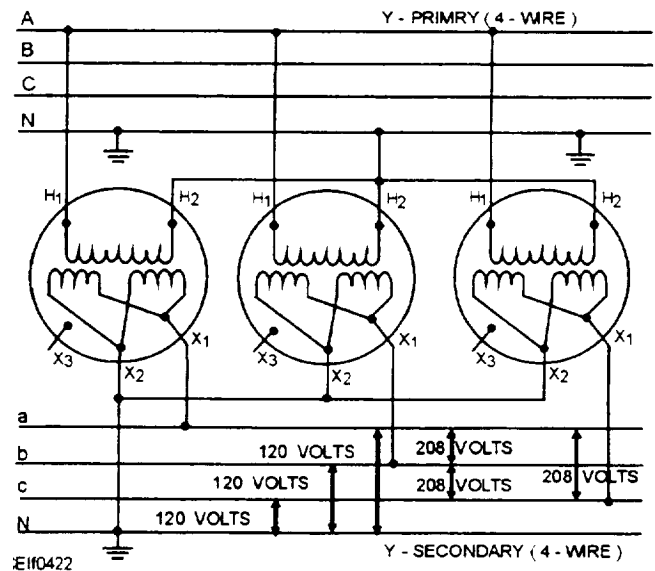

Figure 4-22.—Three single-phase distribution transformers connected wye-wye.

secondary service. Figure 4-23 shows the proper connections for three single-phase distribution transformers connected to a three-phase three-wire ungrounded neutral delta primary-voltage system to obtain 208Y/120- or 480Y/277-volt secondary service.

Transformers must be constructed with the proper windings for the primary-voltage system and the desired secondary voltage. Properly manufactured distribution transformers can be connected wye-delta if it is desired to obtain three-wire three-phase secondary voltages from a three-phase four-wire ground neutral wye primary-voltage system. The

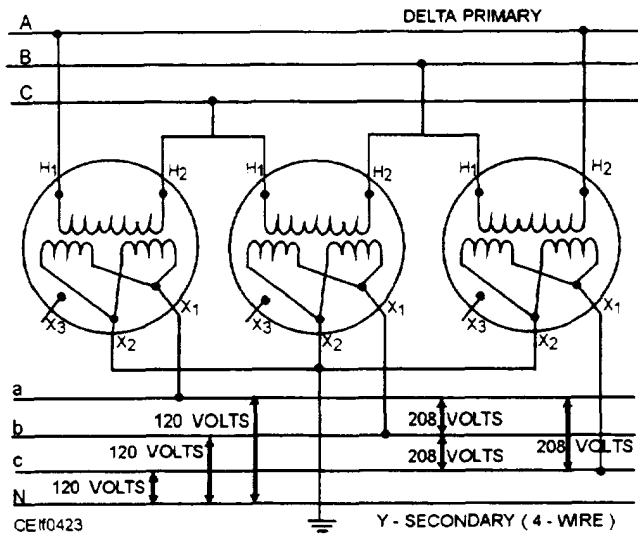

Figure 4-23.—Three single-phase distribution transformers connected delta-wye.

standard secondary system three-phase voltages are 208Y/120, 240, 480Y/277, and 480 volts.

If one of the transformers from a delta connected bank is removed, the remaining two are said to be open-delta-connected. With one transformer removed, the remaining two transformers will still transform the voltages in all three phases and supply power to all three phases of the secondary mains. The proper connections, using two transformers to obtain three-phase service, for a delta primary circuit are shown in figure 4-24. The capacity of the two transformers is now, however, only 58 percent instead of 66 2/3 percent of what it would appear to be with two transformers.

The open-delta connection is often used where an increase in load is anticipated. The third unit is added when the load grows to the point at which it exceeds the capacity of the two transformers. Furthermore, if one transformer of the three-phase bank should become defective, the defective transformer can be removed and the remaining two transformers continue to render service to at least part of the load.

Capacitors

Power capacitors are used in distribution systems to supply reactive voltamperes (Vars) to the system. When applied to a system or circuit having a lagging power factor, you can obtain several beneficial results. These results include power factor increase, voltage increase, system loss reduction, and an increase of electric system capacity.

POWER FACTOR.—When an alternating voltage and the current, which it causes to flow, rise

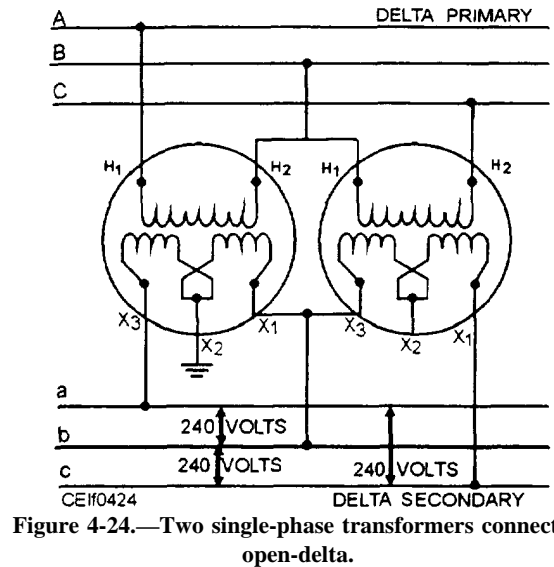

Figure 4-24.—Two single-phase transformers connected open-delta.

and fall in value together in the same direction at the same instant, the two are said to be "in phase," and the power factor is unity or 1.0. This condition is shown in figure 4-25.

The current and voltage waves are not in phase in most cases. They do not rise and fall in value together, nor do they have the same direction at the same instant; but instead, the current usually lags behind the voltage. Figure 4-26 shows the usual condition in transmission

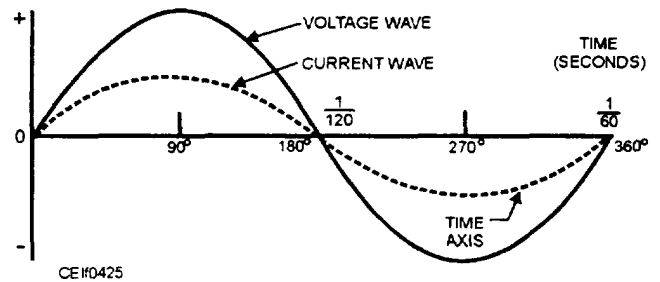

Figure 4-25.—Voltage and current waves are in phase; power factor is unity.

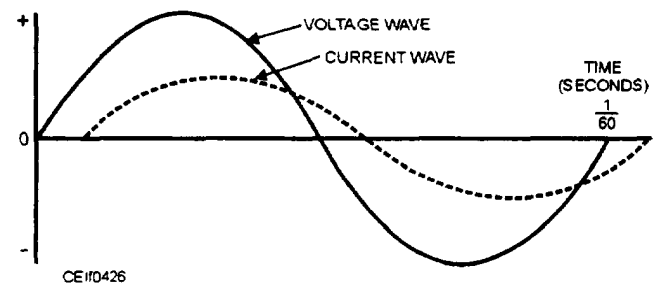

Figure 4-26.—Current wave lagging behind the voltage wave, usual condition in transmission and distribution systems.

Table 4-2.—Power Factor of Various Types of Electrical Equipment

Equipment	Power Factor	Lagging/Leading
Incandescent lights	100%	In phase
Heating devices (all types)	100%	In phase
Induction motors (loaded)	80%	Lagging
Induction motors (light load)	20%	Lagging
Neon lights	30-70%	Lagging
Synchronous motors (underexcited)	Varies	Lagging
Synchronous motors (overexcited)	Varies	Leading
Static condensers	0%	Leading

and distribution circuits. The current and voltage are now said to be "out of phase." The current drawn by idle running induction motors, transformers, or underexcited synchronous motors lags even more than the current shown in the figure.

Occasionally, the current leads the voltage. An unloaded transmission line, an overexcited synchronous motor or a static condenser takes leading current from the line. When the current leads or lags the voltage, the power in the circuit is no longer equal to volts times amperes but is calculated from the expression:

$$\text{Watts} = \text{volts} \times \text{amperes} \times \text{power factor}$$

$$\text{Power factor} = \frac{\text{watts}}{\text{volts} \times \text{amperes}}$$

The "power factor" can thus be defined as the ratio of the actual power to the product of volts times amperes. The latter product is generally called voltamperes, or apparent power. The value of the power factor depends on the amount the current leads or lags behind its voltage. When the lead or lag is large, the power factor is small; and when the lead or lag is zero, as when the current and voltage are in phase, the power factor is unity. Unity is the largest value that the power factor can have. The power factor is usually between 0.70 and 1.00 lagging. An average value often used in making calculations is 0.80 lagging. Table 4-2 gives the power factors of various types of electrical equipment.

The cause of low power factor is an excessive amount of inductive effect in the electric consuming device, be it motor, transformer, lifting magnet, and so forth. Induction motors, when lightly loaded, exhibit a pronounced inductive effect. Idle transformers likewise

have a strong tendency to lower the power factor. A low system power factor can be increased by adding corrective equipment to the system. There are many devices used for power factor correction, including synchronous motors and power factor correction capacitors.

SYNCHRONOUS MOTORS.—Any synchronous motor may be used for power factor correction by overexcitation.

POWER FACTOR CORRECTION CAPACITORS.—For general use, the most practical and economical power factor correction device is the capacitor. Capacitors are used at power stations where an elaborate and expensive synchronous condenser installation is not justified. The following paragraphs deal exclusively with power capacitors.

Capacitance is the direct opposite of inductance, just as heat is the opposite of cold, and day is opposite of night. Capacitance is a property of a condenser, and a condenser is a combination of metal plates, or foil strips, separated from each other by an insulator, such as air, paper, or rubber. The capacitance, or the capacity of the condenser to hold an electric charge, is proportional to the size of the plates and increases as the distance between the plates decreases.

RATINGS.—Capacitors are rated in continuous kvar (kilovoltampere reactive), voltage, and frequency. They are designed to give not less than rated and not more than 135 percent rated kvar when operated at rated voltage and frequency. Capacitor units are available normally in voltage ratings of 2,400 volts to 34,500 volts and kvar ratings from 15 kvar to 300 kvar. Various manufacturers' medium-voltage units up to 200 kvar are interchangeable. Capacitors are generally rated at a frequency of 60 Hertz (Hz);

however, they also are suitable for operation at frequencies below 60 Hz. There is no physical limit to the underfrequency operation of the capacitors. The limit is economic, in that the capacitor kvar output is directly proportional to frequency and applied voltage. If a capacitor is operated at a frequency lower than rated, its kvar rating is reduced. Since capacitors are installed in theory to use their rated capacity, utilization at reduced frequencies is not economical, as the design rating of the unit can never be achieved.

One method of raising the power factor is to add capacitors to the circuit, since capacitance is the opposite of inductance and since too much inductance is the cause of low power factor. Capacitors are installed underground on underground distribution circuits or mounted on poles, as shown in figure 4-27. The pole-mounted three-phase bank capacitors shown in figure 4-27 are rated 1,200 kVA capacitance and 13,200Y/7,620 volts; this bank is complete with switches, fuses, and lightning arresters. The capacitors can be directly connected to the circuit or switched on

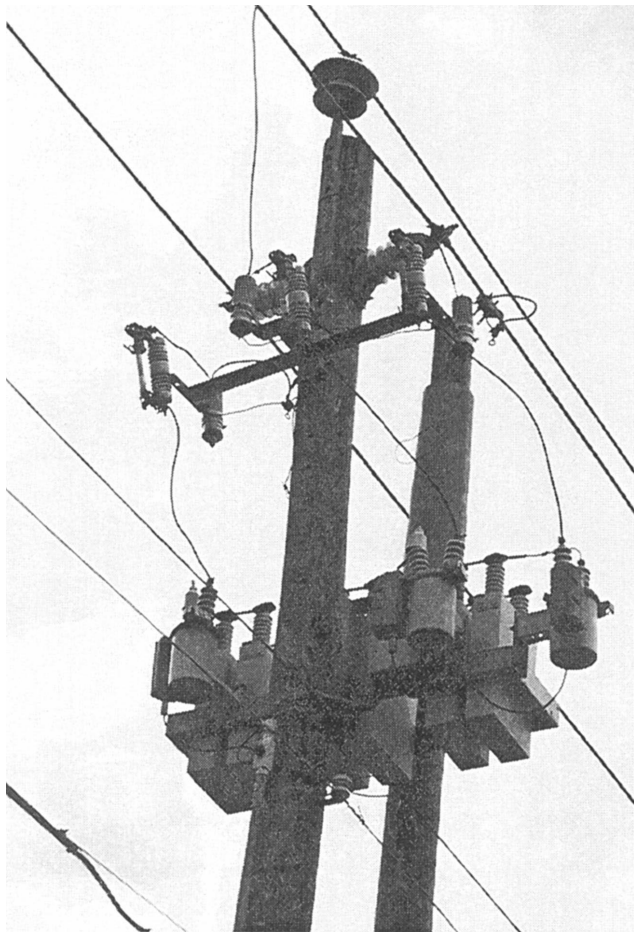

Figure 4-27.—Cluster-mounted bank of 4 three-phase capacitors.

and off as needed. An underground capacitor bank may be equipped with oil switches for energizing three to six capacitors. The capacitor equipment may be installed in a 36-inch diameter vault.

FIXED CAPACITORS.—Fixed capacitor installations are those that are continuously on the line. Fixed capacitor banks are connected to the system through a disconnecting device that is capable of interrupting the capacitor current, allowing removal of the capacitors for maintenance purposes. Fixed capacitor banks should be applied to give a voltage boost to the system during heavy load periods. Caution must be used, however, to ensure the boost will not be excessive during light-load conditions. To isolate or de-energize a fixed capacitor installation, you should open the disconnecting switches with rapid positive action. The successful switching of capacitors depends, to a considerable extent, on the technique of the operator and the speed of opening. It is more difficult to de-energize a capacitor bank than it is to energize it, because the ease with which capacitor current is interrupted depends on the point on the voltage wave when the switch contacts separate. If the arc is reestablished and maintained with the disconnecting device open, the switch should be reclosed at once to avoid damage to the switch. Another attempt should then be made to open the disconnecting device. After the disconnecting device has been opened, the capacitor installation is isolated but still charged. The capacitors should be left open from the line for at least 5 minutes before they are returned to service. This precaution will prevent a buildup of the line voltage above normal, which may occur if a fully charged capacitor bank is closed on a line.

CAPACITOR CONNECTIONS.—A typical three-phase capacitor bank oil switch can be a three-pole device or three single-pole devices that can be controlled automatically to switch the bank in or out of service to control the power factor or to regulate system voltage. Fuses provide short-circuit protection. If automatic switching is not required, the fuses can be used as load-break switches by using a portable load-break tool.

SWITCHED CAPACITORS.—Switched capacitor installations are those where the capacitor bank is switched in and out of service, depending upon system operating conditions. They are usually switched on when the load requirements are the greatest and switched off during light-load conditions. Sometimes the capacitor banks are installed to enable

incremental switching, depending on the system reactive requirements and the amount of system voltage required. To remove a switched capacitor bank from service, you should open the control box and the automatic control lever. or control switch, should be placed in the OFF position. The circuit breaker or the switching device should then be tripped. To ensure the circuit breaker or switching device remains open, you should remove the fuses from the control circuit. Before it can be assumed that the capacitor bank has been de-energized, the position of the switching device should be inspected. On a circuit breaker, the position indicator should be checked. For oil switches, the position of the operating handle can be checked with a switch stick.

CAPACITOR PRECAUTIONS.—Capacitors and transformers are entirely different in their operation. When a transformer is disconnected from the line, it is electrically dead. Unlike the transformer and other devices, the capacitor is not dead immediately after it is disconnected from the line. It has the peculiar property of holding its charge because it is essentially a device for storing electrical energy. It can hold this charge for a considerable length of time. There is a voltage difference across its terminals after the switch is opened.

Capacitors for use on electrical lines, however, are equipped with an internal-discharge resistor. This resistor, connected across the capacitor terminals, will gradually discharge the capacitor and reduce the voltage across its terminals. After 5 minutes, the capacitor should be discharged.

To be perfectly safe, however, proceed as follows: Before working on a disconnected capacitor, wait 5 minutes. Then test the capacitor with a high-voltage tester rated for the circuit voltage. If the voltage is zero, short-circuit the terminals externally using hot-line tools and ground the terminals to the case. Now you can proceed with the work.

COUPLING CAPACITORS.—Communication signals in the form of high-frequency voltages are transmitted to the transmission lines through coupling capacitors. Some of the coupling capacitors are equipped with potential devices that make it possible to measure the voltage on transmission line circuits. The coupling-capacitor potential devices are accurate enough to be used for supplying voltage to protective relays but, unless they are specifically compensated, not accurate enough to supply voltage for meters designed for billing purposes. Figure 4-28 shows a coupling capacitor.

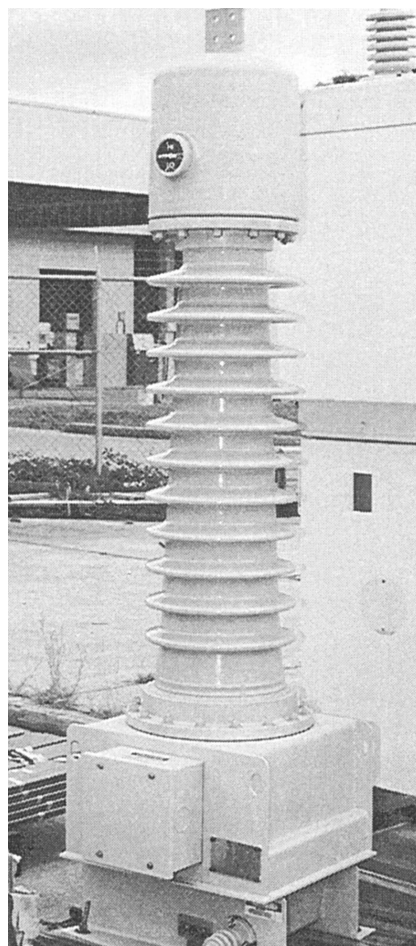

Figure 4-28.—Coupling capacitor.

TYPES OF SWITCHING DEVICES.—Switching capacitors imposes severe duty on switching devices because of the differences in phase relationship between the current and voltage on a capacitor circuit. When a capacitor bank is energized, high transient overvoltages and high-frequency transient inrush currents may be produced. The magnitude of the transient overvoltages easily may be three times the rated line voltage, and transient inrush currents may approach the short-circuit current duty values. These factors are especially important when one or more capacitor banks already is energized and another one at the same location is switched on to the bus. The methods for determining the values of inrush current, transient overvoltage, and resonant frequency of the circuit are discussed in more detail in ANSI C37.99, *IEEE Guide for Protection of Shunt Capacitor Banks*, and ANSI C37.012, *Application Guide for Capacitance Current Switching of AC High-Voltage*

Circuit Breakers Rated on a Symmetrical Current Basis.

Switching devices, as discussed below, have a separate capacitive switching rating for the reasons mentioned above; and the switching rating of the device must be at least 135 percent of the capacitor bank rating to which the switching device is connected. This 135 percent rating is a minimum specified by the *National Electrical Code(NEC)*[®] and includes allowance for operation at overvoltage, allowance for capacitance manufacturing tolerance, and allowance for harmonic components above the fundamental frequency.

CONSTRUCTION.—A capacitor unit consists of two aluminum foil strips, or plates, with a thin high-grade insulating paper or a synthetic film placed between them. The strips, or plates, are compactly wound and connected in groups, each of which is connected to a terminal. There is no contact between the two metal surfaces. When these two surfaces are connected to a source of power, energy is stored in the capacitor. The capacitor remains charged at, or above: full-line voltage when disconnected from the source of power until a discharge path is provided between the terminals. Capacitors have a built-in discharge resistor designed to drain off or reduce this residual charge. *NEC*[®] requires capacitors rated 600 volts or more to be discharged to a residual voltage of 50 volts or less in 5 minutes. Since the built-in resistor has the disadvantage that it cannot be visually inspected for an open circuit, it should not be relied upon for positive drain off of the residual charge. The wound plates and discharge resistor of a capacitor are enclosed in a welded sheet steel or stainless steel container, which is hermetically sealed to protect the capacitor from deterioration due to entrance of foreign material or moisture. The contents are vacuum dried and are usually impregnated with a dielectric fluid. As of 1 October 1977, dielectric fluids containing polychlorinated biphenyls (PCBS) can no longer be installed. The connecting leads from the capacitor are brought up through the bushings to a joint at the top directly under the brazed terminal. The bushings supplied on capacitors are usually made of porcelain. As of 1 October 1988, existing PCB capacitors in unrestricted areas must be removed.

TYPES OF INSTALLATIONS.—The greatest electrical benefits are derived from capacitors connected directly at the loads. This connection permits maximum loss reduction and released line capacity. However, economics and physical

limitations are usually the governing factors. Capacitors may be divided into two classes: primary capacitors and secondary capacitors. Primary capacitors are those rated 2,400 volts and above. Secondary capacitors are those used on the low-voltage side of distribution transformers or at motor terminals and are normally rated 600 volts and below. The three most common types of power capacitor installation are as follows: pole mounted, metal enclosed, and open rack.

Pole Mounted.—Pole-mounted capacitors are packaged as a complete unit containing all necessary items for a switched distribution capacitor bank installation. The banks consist of an aluminum- or steel-mounting frame that supports the capacitor units, interconnecting wiring, and capacitor switches. Overcurrent, protection is usually provided by group fuses.

Metal Enclosed.—Metal-enclosed capacitor banks consist of a factory-assembled group of individual capacitor units mounted in a protective housing complete with bus connections, controls, and protective and switching equipment within the enclosure. Personnel safety and compactness are the major benefits. Each capacitor unit normally is protected by an individual current-limiting fuse.

Open Rack.—An open-rack capacitor installation (fig. 4-29) is a field-assembled group of capacitor units mounted in an open-rack structure without enclosing plates or screens. Open-rack installations normally are made up of several stack type of capacitors connected in parallel to provide desired kvar capacity. All the units in a given stacking unit are normally connected in parallel with the steel frame forming one terminal and the insulated bus forming the other. For open-rack installations the capacitor units are protected by individual fuses, group fuses or relays, and a circuit breaker.

CAPACITOR MAINTENANCE.—All switched capacitor banks should be inspected and checked for proper operation once each year before the time period when they are automatically switched on and off to meet system requirements. A suggested reading source for capacitor maintenance is *The Lineman's and Cableman's Handbook*.

Capacitor-bank oil switches should be maintained on a schedule related with the type of on/off controls installed at each bank. The maximum number of open and close operations between maintenance of the switches normally should not exceed 2,500.

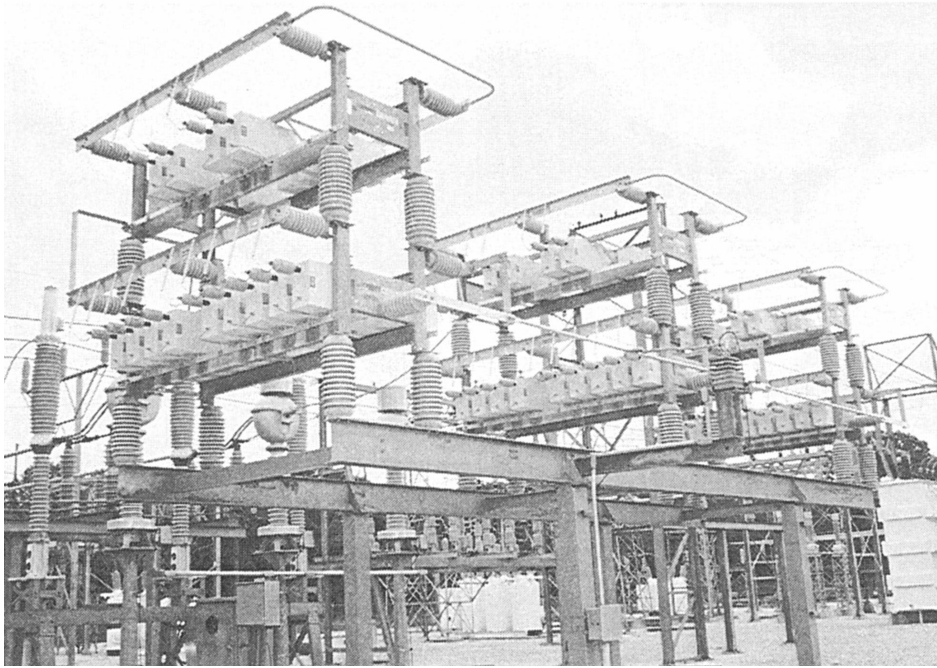

Figure 4-29.—Capacitors, open-rack installation.

Experience has shown that the following schedule normally will keep the equipment operating properly:

TYPE CONTROL	YEARS
Time clock	3
Voltage	3
Dual temperature	5
Temperature only	8
Time clock and temperature	8

The capacitor switches usually are removed from the distribution line by the lineman and replaced with a spare unit during the season in which they normally are not operated. The capacitor switches can be maintained efficiently in a distribution shop by the lineman.

Protective/Interrupting Devices

A power distribution circuit, like any other electrical circuit, requires the use of special devices to provide control and to protect the system from internal or external influences that may damage the circuit. Overcurrent/overvoltage protection and personnel safety, requirements are provided in a power

distribution system by the use of lightning arresters, cutouts, fuses, air switches, and oil switches.

LIGHTNING OR SURGE ARRESTERS.—A surge arrester is a device that prevents high voltages, by providing a low-impedance path to ground for the current from lightning or transient voltages, and then restores normal circuit conditions.

Surge arresters perform a function on the electric system similar to that of a safety valve on a steam boiler. A safety valve on a boiler relieves high pressure by blowing off steam until the pressure is reduced to normal. When the pressure is reduced to normal, the safety valve closes and is ready for the next abnormal condition. When a high voltage (greater than the normal line voltage) exists on the line, the arrester immediately furnishes a path to ground and thus limits and drains off the excess voltage. Furthermore, when the excess voltage is relieved, the action of the arrester must prevent any further flow of power current. The function of a surge arrester is, therefore, twofold—first, to provide a point in the circuit at which the overvoltage impulse can pass to earth without injury to line insulators, transformers, or other connected equipment and, second, to prevent any follow-up power current from flowing to ground.

DISTRIBUTION CUTOUT.—A distribution cutout provides a high-voltage mounting for the fuse element to protect the distribution system or the equipment connected to the system (fig. 4-30). Distribution cutouts are used with installations of

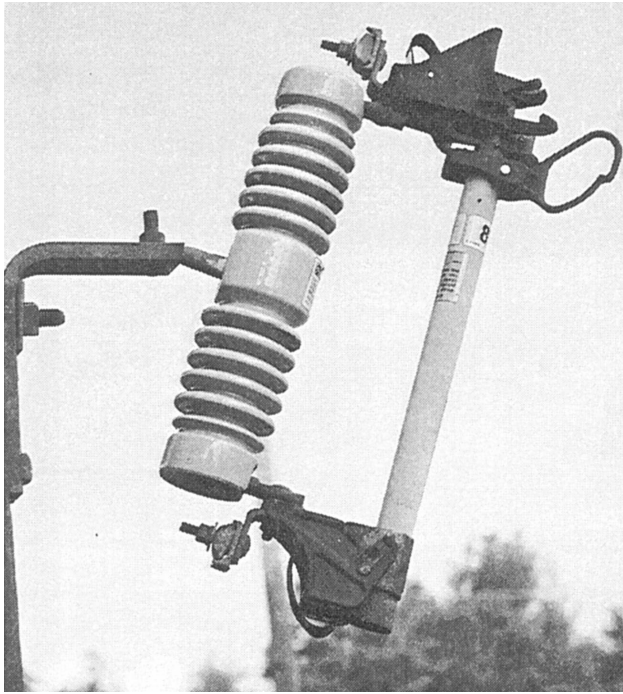

Figure 4-30.—Mounted distribution cutout with expulsion fuse.

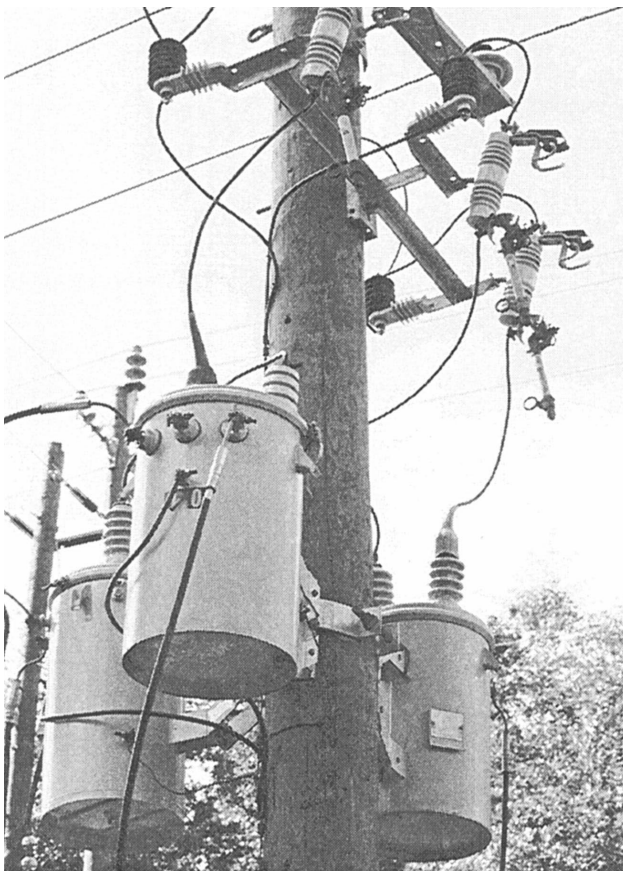

Figure 4-31.—Distribution cutouts installed for transformer bank switching.

transformers, capacitors, cable circuits, and sectionalizing points on overhead circuits (fig. 4-31). Enclosed, open, and open-link cutouts are used for different distribution circuit applications. Cutouts normally use an expulsion fuse. An expulsion fuse operates to isolate a fault or overload from a circuit. The arc from the fault current erodes the fuse holder tube producing a gas that blasts the arc out through the fuse tube vent(s) thereby isolating the circuit.

The mechanical differences between enclosed, open, and open-link cutouts are in their external appearance and methods of operation. Enclosed cutouts have terminals, fuse clips, and fuse holders mounted completely within an insulating enclosure. Open cutouts, as the name indicates, have these parts completely exposed.

The construction of the cutout fuse holder can provide for non-dropout or dropout operation. Some of the fuses are manufactured to provide indication that the fuse is blown; other fuses may have an expendable cap.

ENCLOSED DISTRIBUTION CUTOUT.—In an enclosed distribution fuse cutout the fuse clips and fuse holder are mounted completely within an enclosure. A typical enclosed cutout, as shown in figure 4-32, has a porcelain housing and a hinged door supporting the fuse holder. The fuse holder is a hollow vulcanized-fiber expulsion tube. The fuse link is placed inside the tube and connects with the upper and lower line terminals when the door is closed. When the

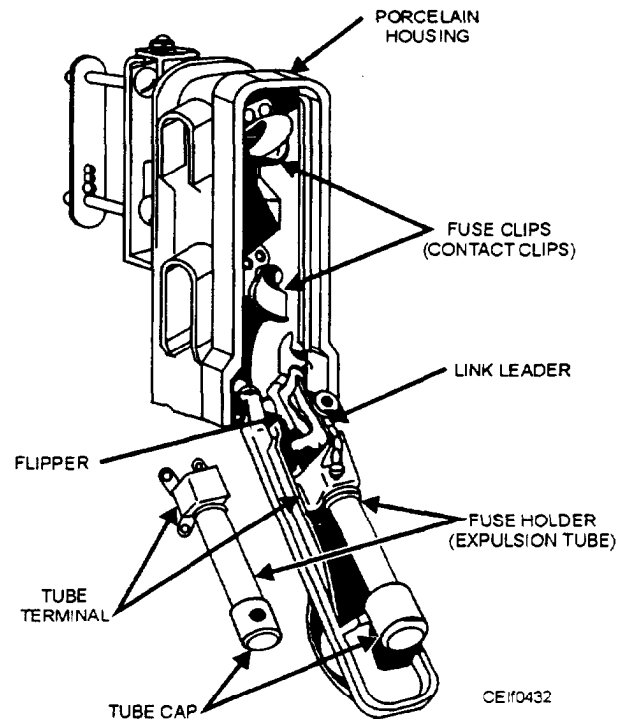

Figure 4-32.—Enclosed primary cutout assembly.

fuse blows or melts because of excessive current passing through it, the resultant arc attacks the walls of the fiber tube, producing a gas which blows out the arc. The melting of the fusible element of some cutouts causes the door to drop open, signaling to the lineman that the fuse has blown.

Each time the fuse blows, a small amount of the vulcanized fiber of the expulsion tube is eroded away. The larger the value of the current interrupted, the more material is consumed. In general, a hundred or more operations of average current values can be performed successfully before the cutout fails.

Enclosed cutouts can be arranged to indicate when the fuse link has blown by dropping the fuse holder. The enclosed cutout is designed and manufactured for operation on distribution circuits of 7,200 volts and below. The standard current ratings of the cutouts are 50, 100, or 200 amps.

OPEN DISTRIBUTION CUTOUT.—Open types of cutouts are similar to the enclosed types except that the housing is omitted (fig. 4-33). The open type of cutout is designed and manufactured for all distribution system voltages. The open type is made for 100- or 200-amp operation. Some cutouts can be uprated from 100 to 200 amps by using a fuse tube rated for 200-amp operation.

PRIMARY FUSE LINKS.—A primary fuse link consists of the button, upper terminal, fusible element, lower terminal, leader, and sheath. The button is the upper terminal and the leader is the lower terminal. Fuse links for open-link cutouts are similar to the primary fuse link except that open-link cutouts have pull rings at each end. In either case, the sheath aids in the interruption of low-value faults, and it provides protection against damage during handling.

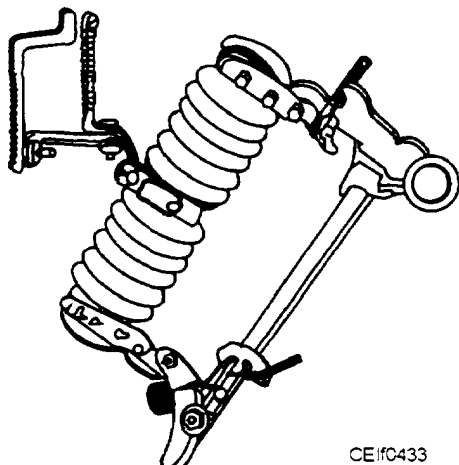

CEIf0433

Figure 4-33.—Open-distribution cutout.

Standards specify the size of the fuse holder into which the link must fit freely. Links rated 1 to 50 amps must fit into a 5/16-inch diameter holder, 60- to 100-amp links must fit into a 7/17-inch diameter holder, and 125 to 200-amp links must fit into a 3/4-inch diameter holder. Links must withstand a 10-pound pull while carrying no load current but are generally given a 25-pound test.

Fusible elements are made in a wide variety of designs. Most silver-element fuse links use the helically coiled construction. This construction permits the fusible element to absorb vibration as well as thermal shock due to current surges and heating and cooling throughout the daily load cycle.

FUSE LINK OPERATION.—When a fault occurs, the fusible element is melted by the excessive current, and an arc forms across the open gap. The arc is sustained temporarily in a conducting path of gaseous ionized arc products. Gas pressure builds rapidly; and this pressure, acting in conjunction with a spring-loaded flipper at the lower end of the fuse tube, rapidly ejects the fuse link leader, lengthening and cooling the arc. For low values of fault current, the arc acts on the fuse link sheath, generating considerable amounts of deionizing gases. When the current passes through the next zero value, as it changes the direction of flow, the arc is interrupted (fig. 4-34). As the voltage increases again across the opening in the fuse link, the arc attempts to reestablish itself. A restrike, however, is prevented by the deionizing gases which will have rebuilt the dielectric strength of the open gap. For large values of fault current, the sheath is rapidly destroyed, and the arc erodes fiber from the inner wall of the cutout tube, generating large amounts of deionizing gas. During the fault interruption process, the cutout expels large amounts of gas under high pressure as well

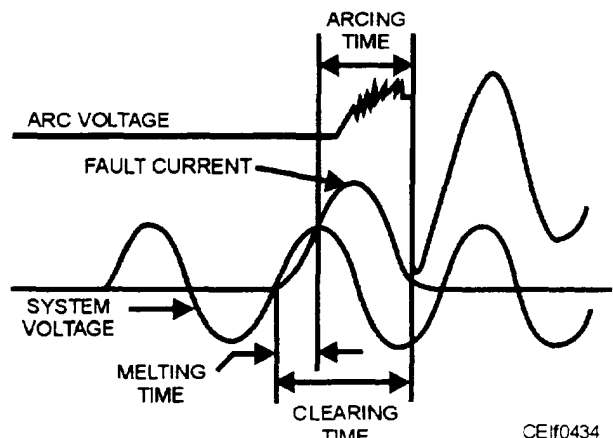

CEIf0434

Figure 4-34.—Diagram of voltages, current, and timing reference recorded with an oscillograph to show fuse operation.

as some fuse link particles. There also may be a very loud report. Accordingly, when one is working in the vicinity of a fuse cutout, care should be taken to stay clear of the exhaust path. In addition, when closing a cutout, it is good practice to look down, away from the discharge path, since there is always the possibility of closing the cutout into a short circuit.

RECOMMENDED SIZE OF PRIMARY FUSE.—Table 4-3 gives the recommended size of primary fuses to use with different transformer voltage and kilovoltampere ratings. The table also gives the normal full-load primary current rating of the transformer.

It is general practice not to protect distribution transformers against small overloads. To do so would cause unnecessary blowing of the fuses and frequent interruption of the service, both of which are undesirable. It is customary, therefore, to provide fuses which have a higher current rating than the current rating of the transformer.

AIR SWITCHES.—As their names imply, air switches are switches whose contacts are opened in air.

Air switches are further classified as air circuit breakers, air-break switches, and disconnects.

Circuit Breaker.—A device used to complete, maintain, and interrupt currents flowing in a circuit under normal or faulted conditions is called a circuit breaker. The circuit breaker has a mechanism that mechanically, hydraulically, or pneumatically operates the circuit breaker contacts. Insulating oil, air, compressed air, vacuum, or sulfur hexafluoride gas is used as an arc-interrupting medium and a dielectric to insulate the contacts after the arc is interrupted. If the circuit is to open automatically during overload or short circuit conditions, the circuit breaker is equipped with a tripping mechanism to accomplish this. Thus, circuit breakers normally are used where control of the circuit, as well as protection from overload, short circuit, and so forth is desired, such as at generating stations and substations.

Air-Break Switch.—The air-break switch can have both blade and stationary contacts equipped with arcing horns. These horns are pieces of metal between which the arc forms when a current-carrying circuit is opened. As the switch opens, these horns are spread

Table 4-3.—Fuse Size for Transformer Installations

System Nominal Voltage	2,400		4,160		7,200		12,000		13,800		
	Transformer kVA Rating	Full-Load Current	Fuse Amp Rating	Full-Load Current	Fuse Amp Rating	Full-Load Current	Fuse Amp Rating	Full-Load Current	Fuse Amp Rating	Full-Load Current	Fuse Amp Rating
SINGLE-PHASE TRANSFORMERS											
5	2.1	3	1.2	3	0.7	3	0.4	3	0.4	3	
10	4.2	7	2.4	5	1.4	3	0.8	3	0.7	3	
15	6.3	10	3.6	5	2.1	3	1.3	3	1.1	3	
25	10.4	15	6.0	10	3.5	5	2.1	3	1.8	3	
37.5	15.6	25	9.0	15	5.2	10	3.1	5	2.7	5	
50	20.8	30	12.0	20	7.0	10	4.2	7	3.6	5	
75	31.3	50	18.0	25	10.4	15	6.3	10	5.4	10	
100	41.7	65	24.0	40	13.9	20	8.3	15	7.2	10	
167	69.6	100	40.1	65	23.2	40	13.9	20	12.1	20	
250	104.2	150	60.1	100	34.8	50	20.8	30	18.1	25	
THREE-PHASE TRANSFORMERS											
9	2.2	3	1.3	3	0.7	3	0.4	3	0.4	3	
15	3.6	5	2.1	3	1.2	3	0.7	3	0.6	3	
30	7.2	10	4.2	7	2.4	5	1.4	3	1.3	3	
45	10.8	15	6.3	10	3.6	5	2.2	3	1.9	3	
75	18.1	25	10.4	15	6.0	10	3.6	5	3.1	5	
112.5	27.1	40	15.6	25	9.0	15	5.4	10	4.7	7	
150	36.1	50	20.8	30	12	20	7.2	10	6.3	10	
225	54.2	80	31.3	50	18	25	10.8	15	9.4	15	
300	72.3	100	41.7	65	24	40	14.5	20	12.6	20	
500	120	200	69.5	100	40	65	24.1	40	21.0	30	

farther and farther apart, thereby lengthening the arc until it finally breaks.

Air-break switches are usually mounted on substation structures or on poles and are operated from the ground level (fig. 4-35). In a three-phase circuit all three switches, one in each phase, are opened and closed together as a “gang,” as the system is called. The switches can be operated by a handle connected to the rod extending from the switch to the base of the pole. Remember, the opening of a three-phase gang switch is a two lineman project. One lineman opens the switch; the other lineman is for safety—he watches to ensure that all phases open. Many of the air rods extending from the air-break switches are operated by mechanized equipment connected to the switch-operating rod from a remote location. The automation of distribution circuits has resulted in the installation of many mechanized operators for key break switches so that they can be controlled from a central operations center. Switches for underground distribution circuits usually are installed in pad-mounted switchgear. The switches are operated with the cabinet doors closed to provide protection for the lineman or cableman.

Disconnect Switch.—A disconnect switch is an air-break switch not equipped with arcing horns or other load-break devices. The disconnect switch cannot be opened until the circuit in which it is connected is interrupted by some other means, such as a portable load break tool attached to a hot-line tool. If a disconnect switch is opened while current is flowing in the line, an arc is likely to be drawn between the blade and the stationary contact where the arc might easily, jump across to the other conductor or to some grounded metal and cause a short circuit. The hot arc also could melt part of the metal, thereby, damaging the switch.

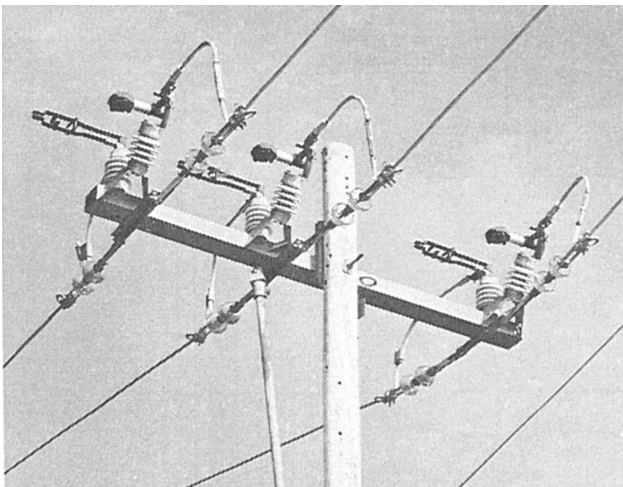

Figure 1-35.—Gang-operated three-pole air-break switch with arc interrupters (in the open position).

Disconnect switches are used to complete a connection to or isolate the following:

1. Two energized transmission or distribution lines
2. Transmission or distribution lines from substation equipment
3. Substation equipment
4. A distribution feeder circuit and a branch circuit

Disconnect switches are frequently used to isolate a line or an apparatus, such as a transformer, to complete maintenance work. In most circumstances, it is necessary to test the equipment for high voltage and, if proved de-energized, to ground it before the maintenance work is performed.

OIL SWITCH.—An oil switch is a high-voltage switch whose contacts are opened and closed in oil. The switch is actually immersed in an oil bath and contained in a steel tank. The reason for placing high-voltage switches in oil is that the oil will break the circuit when the switch is opened. With high voltages, a separation of the switch contacts does not always break the current flow because an electric arc forms between the contacts. If the contacts are opened in oil, the oil will quench the arc. Furthermore, if an arc should form in the oil, it will evaporate part of the oil because of the high temperature and will partially fill the interrupters surrounding the switch contacts with vaporized oil. This vapor develops a pressure in the interrupters which assists in quenching or breaking the arc by elongating the arc.

The three lines of a three-phase circuit can be opened and closed by a single oil switch. If the voltage is not extremely high, the three poles of the switch are generally in the same tank (fig. 3-36); but if the voltage of the line is high, the three poles of the switch are placed in separate oil tanks. The poles are placed in separate tanks to make it impossible for an arc to form between any two phases when the switch is opened or closed. An arc between phases would be a short circuit across the line and would probably blow up the tank.

When an oil switch is to open the circuit automatically because of an overload or short circuit, it is provided with a trip coil. This trip coil consists of a coil of wire and a movable plunger. In low-voltage circuits carrying small currents, this coil is connected in series with the line. When the current exceeds its permissible value, the coil pulls up its plunger. The plunger trips the mechanism, and a spring opens the switch suddenly.

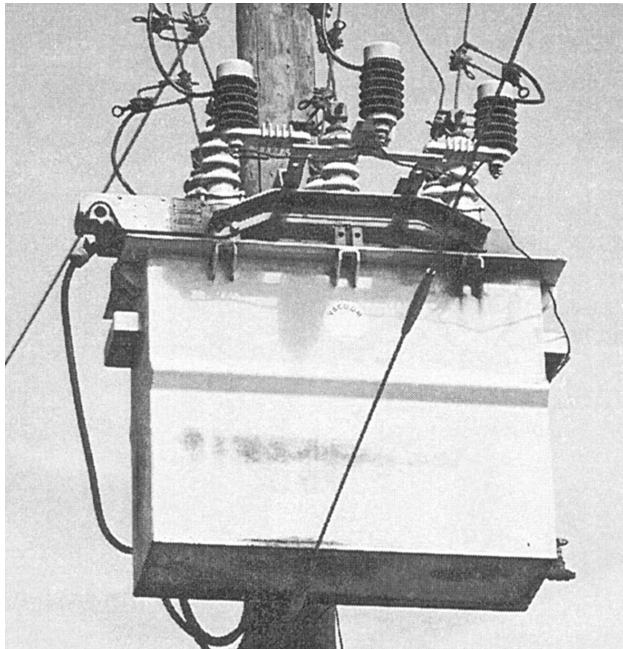

Figure 4-36.—Three-phase oil switch recloser.

In high-voltage circuits or in circuits carrying large currents, a current transformer is connected into the line and the secondary leads from this transformer supply the current to the trip coil of the oil switch (fig. 4-37). Since there is a fixed ratio between primary and secondary currents of the current transformer, the coil can be adjusted to trip at any predetermined value of current in the line.

The use of the current transformer on such circuits serves the dual purpose of providing a small current for operating the tripping coil and insulating the coil from the high voltage of the line.

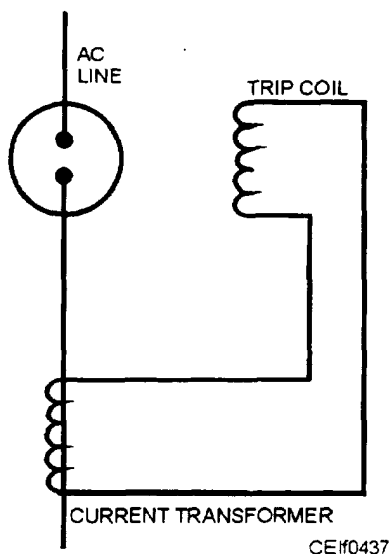

Figure 4-37.—Current transformer used to supply current to the trip coil of an oil switch.

An oil circuit recloser is a type of oil switch designed to automatically interrupt and reclose an alternating-current circuit. It can be made to repeat this cycle several times. Reclosers are designed for use on single-phase circuits or on three-phase circuits.

A recloser opens the circuit in case of fault as would a fuse or circuit breaker. The recloser, however, recloses the circuit after a predetermined time (for hydraulically controlled reclosers about 2 seconds). If the fault persists, the recloser operates a predetermined number of times (1 to 4) and “locks out,” after which it must be manually reset before it can be closed again. If, however, the fault was of a temporary nature and cleared before lockout, the recloser would reset itself and be ready for another full sequence of operations.

Temporary faults arise from wires swinging together when improperly sagged, from tree branches falling into the line, from lightning surges causing temporary flashover of line insulators, and from animals on the conductors short circuiting the insulators.

A recloser is unlike a fuse link because it distinguishes a temporary from a permanent fault. A fuse link interrupts temporary and permanent faults alike. Reclosers give temporary faults repeated chances, usually four, to clear or be cleared by a subordinate device, like a fuse or sectionalizer. If the fault is not cleared after four operations, the recloser recognizes it as a permanent fault and operates to lock out and leave the line open.

A recloser can be magnetically operated by a solenoid connected in series with the line. Minimum trip current is usually twice the normal load current rating of the recloser coil. The operations are performed by a hydraulic mechanism and a mechanical linkage system. When the fault current reaches twice the normal line current, the increased magnetic field pulls the plunger down into the coil. As the plunger moves downward, the lower end trips the contact assembly to open the contacts and break the circuit. As soon as the contacts are open, there is no more current in the coil to hold them open, so a spring closes the mechanism and reenergizes the line.

PROTECTIVE GROUNDS

Protection to the lineman is most important when a transmission or distribution line or a portion of a line is removed from service to be worked on using de-energized procedures. Precautions must be taken to be sure the line is de-energized before the work is started

and remains de-energized until the work is completed. The same precautions apply to new lines when construction has progressed to the point where they can be energized from any source.

The installation of protective grounds and short-circuiting leads at the work site protects against the hazards of static charges on the line, induced voltage, and accidental energizing of the line.

When a de-energized line and an energized line parallel each other, the de-energized line may pick up a static charge from the energized line because of proximity of the lines. The amount of this static voltage “picked up” on the de-energized line depends on the length of the parallel, weather conditions, and many other variable factors. However, it could be hazardous; and precautions must be taken to protect against it by grounding the line at the location where the work is to be completed. Grounding will drain any static voltage and protect the workman from this potential hazard.

When a de-energized line parallels an energized line-carrying load, the de-energized line may have a voltage induced on it in the same manner as the secondary of a transformer. If the de-energized line is grounded at a location remote from where the work is being done, this induced voltage will be present at the work location. Grounding the line at the work location will eliminate danger from induced voltage.

Grounding and short circuiting protect against the hazard of the line becoming energized from either accidental closing of the line or accidental contact with an energized line that crosses or is adjacent to the de-energized line.

The procedures established to control the operation of equipment in an electrical system practically prevent the accidental energizing of a transmission or distribution line. Hold-off tagging procedures have proven to be very effective. If a circuit should be inadvertently energized, the grounds and short circuits on the line will cause the protective relays to initiate tripping of the circuit breaker at the source end of the energized line in a fraction of a second and de-energize the hot line. During this short interval of time, the grounds and short circuits on the line being worked on will protect the workmen (fig. 4-38). If it is not grounded, it is not dead!

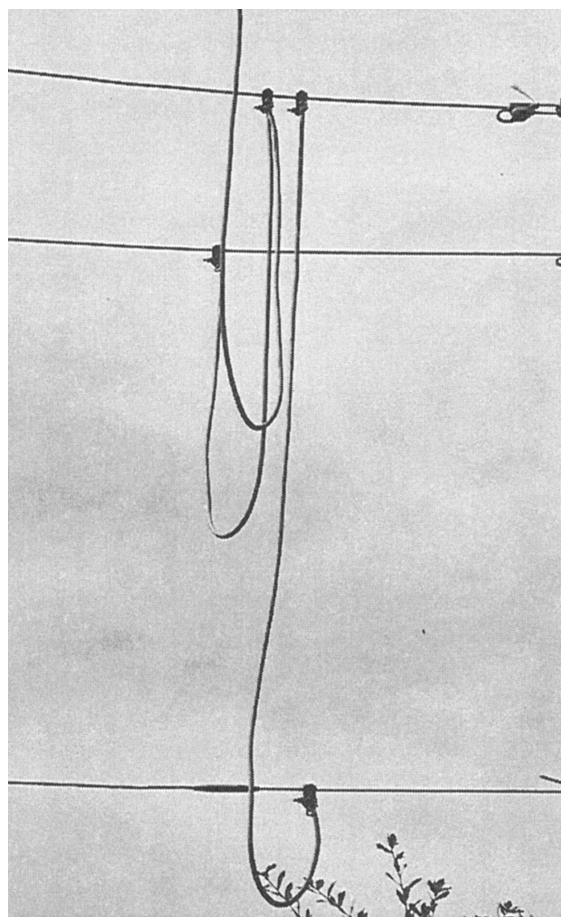

Figure 4-38.—Grounding cluster installation.

UNDERGROUND CONSIDERATIONS

Electric distribution circuits have been installed underground for many years. The conventional underground systems employ the use of some, if not all, of the following: conduits encased in concrete, manholes, ducts and trenches, direct burial cable and riser/potheads, underground power cables, and underground communication cables. After it has been determined that the load density is high enough to justify the expenses associated with an underground system, the system must be designed; and then construction may begin.

MANHOLES

Manholes, handholes, and vaults will be designed to sustain all expected loads that may be imposed on the structure. The horizontal or vertical design loads will consist of dead load, live load, equipment load, impact, load due to water table or frost, and any other load expected to be imposed on or occur adjacent to the

structure. The structure should sustain the combination of vertical and lateral loading that produces the maximum shear and bending moments in the structure.

Manholes are necessary in a power distribution system to permit the installation, removal, splicing, and rearrangement of the cables. A manhole is merely a subterranean vault or masonry chamber of sufficient size to permit proper manipulation of the cables. Arranged on the sides of the vault are devices that support the cables.

The location of manholes is determined largely by the layout of the base that is to be supplied with power. Whenever a branch or lateral extends from the main subway, there must be a manhole; and there must be manholes at intersections of subways. In general, cables are not made in lengths exceeding 400 to 600 feet; and as it is necessary to locate splices in manholes, the distance between manholes cannot exceed these values. Furthermore, it is not advisable to pull in long lengths of cable because the mechanical strain on the conductors and sheath may then become too great during the pulling-in process. It is recommended that manholes be located not more than 500 feet apart. The lines should preferably be run straight between manholes.

Manholes are made in many shapes and sizes to meet the ideas of the designer and to satisfy local conditions. An example of a typical manhole is shown in figure 4-39. If there are obstacles at the point where a manhole is to be located, the form of the manhole must be modified to avoid them. The form approximating an ellipse (fig. 4-40) is used so that the cables will not be abruptly bent in turning them around in the manhole. When the rectangular type of manhole is used (fig. 4-41), care must be taken not to bend the cables too sharply.

The size of a manhole will vary with the number of cables to be accommodated; but, in any case, there must be sufficient room to work in the manhole. A 5- by 7-foot manhole is probably as large as will be required in isolated plant work, while a 3- by 4-foot manhole is about as small as should be used. When transformers are located in a manhole, the size should be increased to allow for working space around the transformer and for ventilation. About 2 or 3 feet of volume should be allowed per kilovoltampere of transformer rating.

Manholes are built of either brick or concrete or of both of these materials. When many manholes are to be built of one size and there are no subterranean

obstructions, concrete is usually the cheapest and the best material. But when only a few are to be constructed or when there are many obstructions, a manhole with a concrete bottom, brick sides, and a concrete top is probably the best. Such a manhole can be constructed without having to wait for concrete to set before you can remove the forms. There is a growing use of precast concrete manholes that are shipped directly to the project site.

A manhole with brick walls is built by first pouring the concrete floor and then building up the brick walls thereon. If the manhole is large, the roof can be either of steel-reinforced concrete or of brick set between rails. Probably for installations in which only a few manholes are to be built, the brick-between-rails method is the best. For a small manhole, no masonry roof is necessary, as the cast-steel manhole cover forms the roof.

Cement mortar for building brick manholes or for conduit construction can be made by mixing together 1 part of cement, 3 parts of sand, and about 1/3 part of water, all by volume.

A concrete manhole is built by first pouring the concrete floor and then erecting the form for the sides. In a self-supporting soil, the sides of the hole constitute the form for the outside of the manhole. If the soil is not self-supporting, there must be an outer form of rough planks (plywood), which is usually left in the ground. Steel reinforcing, such as old rails, must be placed in the concrete top of a large manhole. All reinforcing steel should be completely encased in concrete to prevent corrosion.

Manhole covers should always be made of cast steel and covers should be round so that they cannot drop into the hole accidentally.

So-called watertight covers are seldom used now, as it is not feasible to make a satisfactory watertight cover at reasonable expense. A cover should not be fastened down because if it is and accumulated gas in a manhole explodes, the vault and cover will be shattered. A ventilated cover should be used to allow the escape of gas. The newer types have ventilating slots over approximately 50 percent of their area. Dirt and water will get into the hole, but the dirt can be cleaned out and the water will drain out and no harm will result. If ventilation is not provided, an explosion of gas may occur and do great damage.

When feasible, a sewer connection should lead from the bottom of every manhole. The mouth of the trap should be protected by a strainer made of

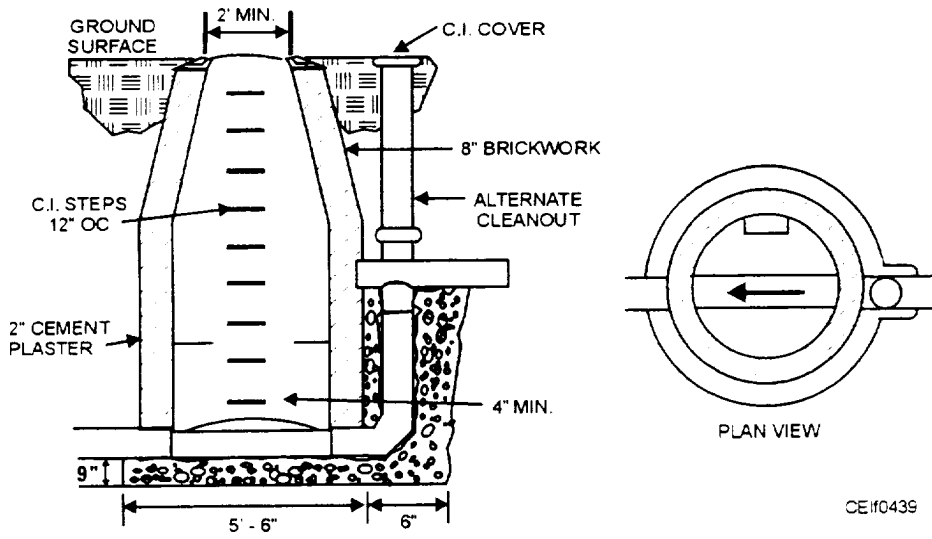
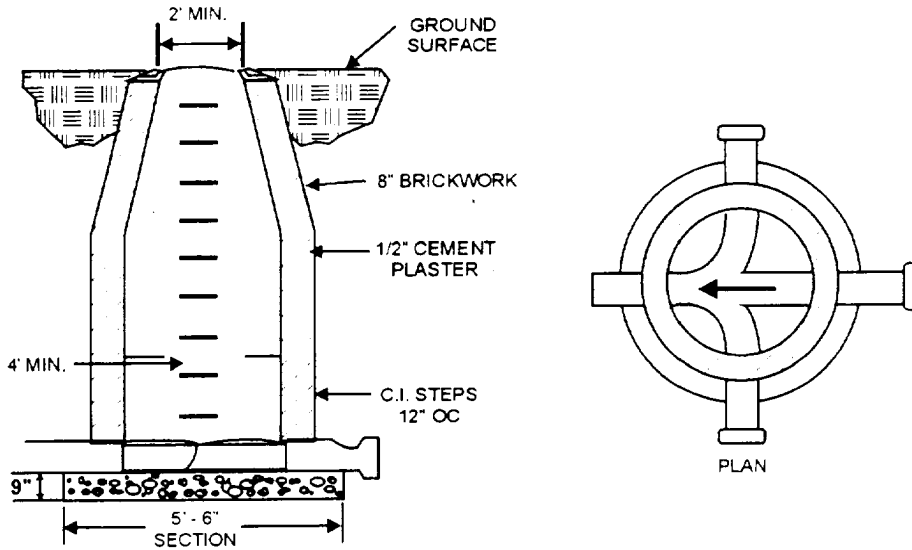

Figure 4-39.—Typical manholes.

noncorrosive wire. If a sewer connection cannot be made, there should be a hole in the manhole floor so that water can drain out. A pocket under the manhole filled with broken rock will promote effective drainage.

WARNING

Before entering any manhole, the vault must be ventilated to remove all toxic or explosive gases and ensure adequate oxygen for survival. Forced air ventilation, respiratory

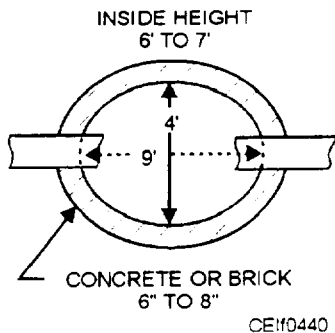

Figure 4-40.—Elliptical type of manhole.

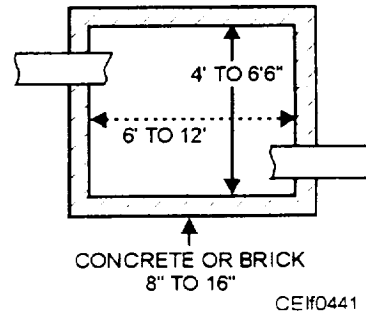
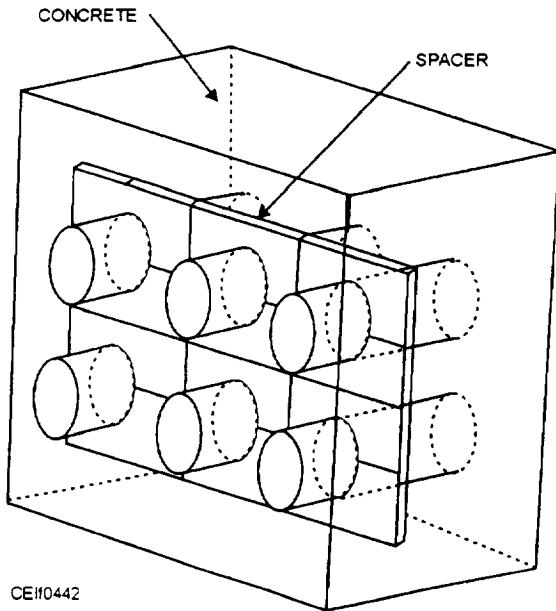

Figure 4-41.—Rectangular type of manhole.

protection, an observer on the surface, and a safety harness and line may be required for safe entry. Consult your supervisor before entering any manhole.

DUCTS AND TRENCHES

A duct line and manhole system provide the best available underground system. Such a system allows for growth and permits cost-effective replacement of existing cables or cable terminations damaged by faults or made obsolete by aging. Concrete encasement provides the cables with minimum susceptibility to damage and optimum safety to personnel. Several types of underground ducts are in general use, such as fiber, wood, vitrified tile, iron pipe, asbestos composition polyvinyl chloride (PVC), and concrete. The most common type used today by the Navy is PVC.



CEI#0442

Figure 4-42.—Spacing fiber duct in concrete.

An underground installation usually consists of several duct lines. Joints between sections should be staggered, so the joints in several lines do not all occur at the same place. To ensure staggering, use starting sections of different lengths at the starting manhole. For duct set in concrete, there must be at least 3 inches of concrete around each line of duct. Where concrete encasement is specified, concrete should have a strength of not less than 2,500 pounds per square inch when cured for 28 days. The 3-inch spacing is accomplished by the use of spacers, like the one shown in figure 4-42. The upper lines of the duct must be a minimum of 3 feet below the ground surface.

The location of the trench varies according to ground condition. The trench should run as straight as possible from one manhole to the next. To ensure drainage, slope the line downward about 1 foot but never less than 3 inches every 100 horizontal feet. When one manhole cannot be located at a lower level than the other, the line must slope downward from about the midpoint both ways toward the manhole, as shown in figure 4-43.

Dig the trench to the desired depth and tamp the bottom hard to ensure a solid bed for the 3-inch bottom layer of concrete. Spacers can be embedded in the bottom layer of concrete for a depth of about 1 inch before the concrete sets to ensure a solid base.

Burying cable directly in the ground is widely done for installations of single circuits for which the cost of duct construction would be prohibitive. Some of the more common applications of direct burial cable are as follows:

1. Street-lighting circuits, especially on a base whose outlying sections are without ducts
2. Connecting residences to mains

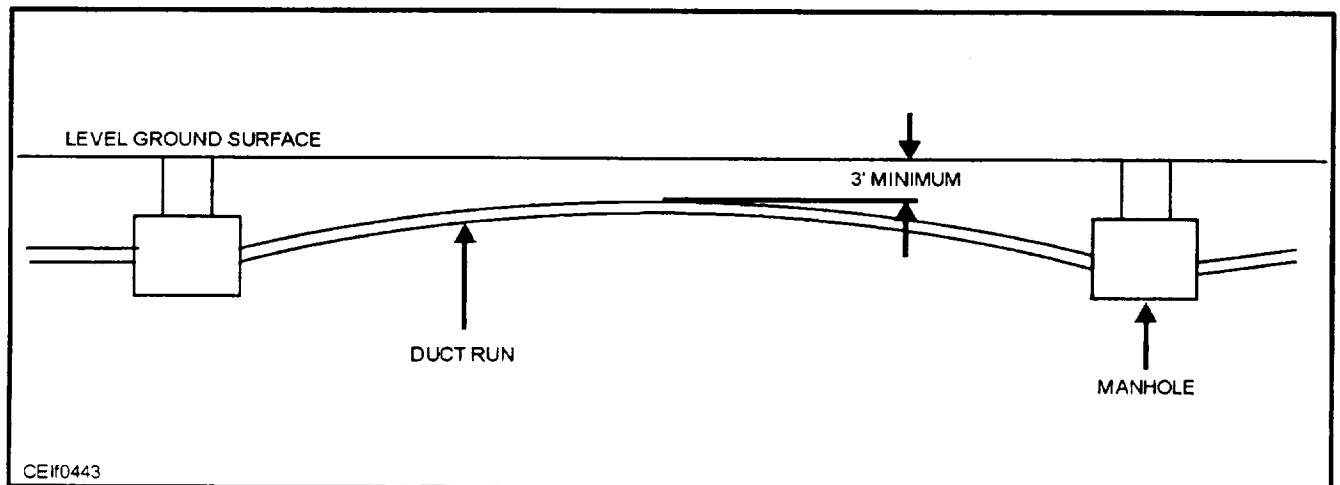

CEI#0443

Figure 4-43.—Slope for duct run.

3. Railroad yards, railway-signal circuits and airport lighting
3. Lighting and power circuits for amusement parks, baseball and football fields, and industrial plants
5. Crossing under small lakes and streams

Both nonmetallic-armored cable and metallic-armored cable (parkway cable) are used for direct burial in the earth. The nonmetallic-armored types are lighter in weight, more flexible, and easier to splice and are not subject to rust, crystallization, induced sheath power loss, or trouble from stray currents. On the other hand, they do not give good protection against mechanical injury.

Direct burial of power cable is normally accomplished with a backhoe digging a trench large enough to permit bed preparation. Whereas communications cable is laid in a small trench created by a chain type of mechanical trencher. Cables are installed at a minimum depth of 30 inches for power cables of 600 Vac or over and 18 inches for communications cables. Cables installed at 30 inches or greater will be protected against extreme mechanical hazard, such as at street intersections or under roadways. The powercables should be placed in a 3-inch-thick bed of sand. When backfilling a direct burial cable, you should place plastic streamers in the trench 12 to 18 inches above the cable. These streamers will alert future personnel conducting digging operations to the presence of the buried cable.

At intervals of 200 feet and at turns in the buried cable, you also should place small-concrete markers along the entire length. These precautionary signs should prevent some future human-related damages to the buried distribution systems. The marker should state the type of cable that is buried, such as power or communications, and voltage or number of pairs.

Types UF and USE cables are code-designated single-conductor or multiconductor cables suitable for direct burial in the earth. The *NEC*[®] includes rules for the protection of underground conductors when the supply voltage exceeds 600 volts. These rules were introduced to minimize the hazards of "dig-ins." Section 710-3(b) of the *NEC*[®] covers such rules.

RISERS/POTHEADS

For connection of underground distribution circuits at any location, the end must be prepared for termination. In earlier times this preparation was accomplished with a pothead, as shown in figure 4-44,

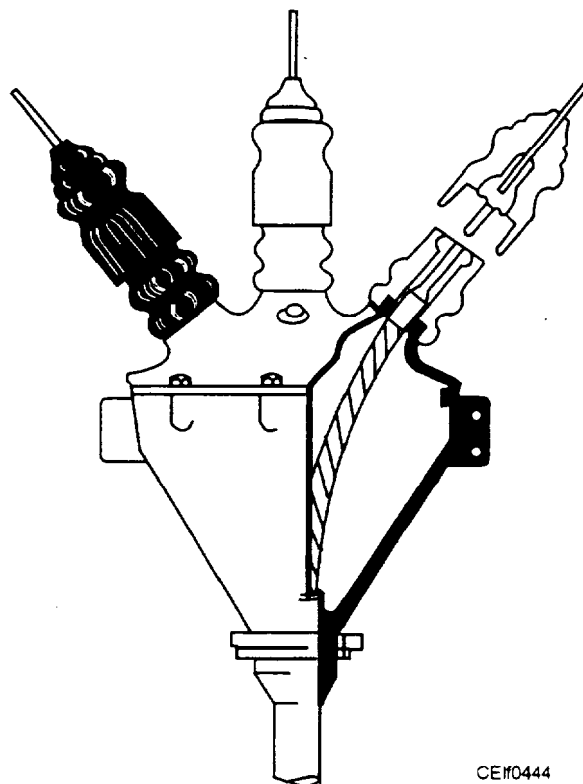
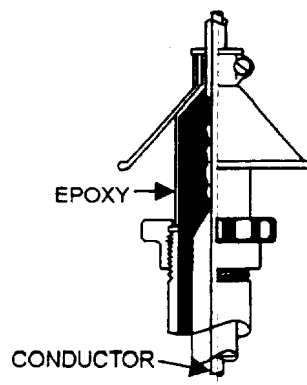

Figure 4-44.—Pothead.

CE#0444

but is now done with special kits which provide plastic molds to be placed over individually prepared phases. The molds are poured full of epoxy. The new way is much more efficient and clean. The new style is shown in figure 4-45.

The riser pole for underground distribution circuits should be inspected when overhead lines are inspected and maintained (fig. 4-46). The inspection should include the disconnect switches or fused cutouts, the lightning arresters, the operation of the arrester ground leads isolation devices, the riser cables and potheads or termination, support of the cables, conduit or U-guard, and identification of the circuit and pole conditions.



CE#0445

Figure 4-45.—Diagram of a modern single-phase cable end termination kit.

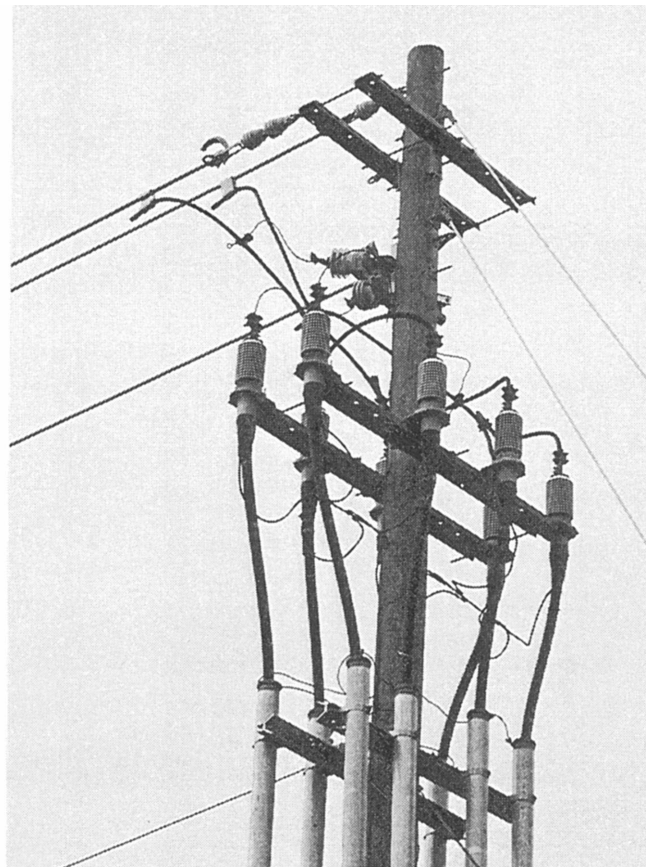
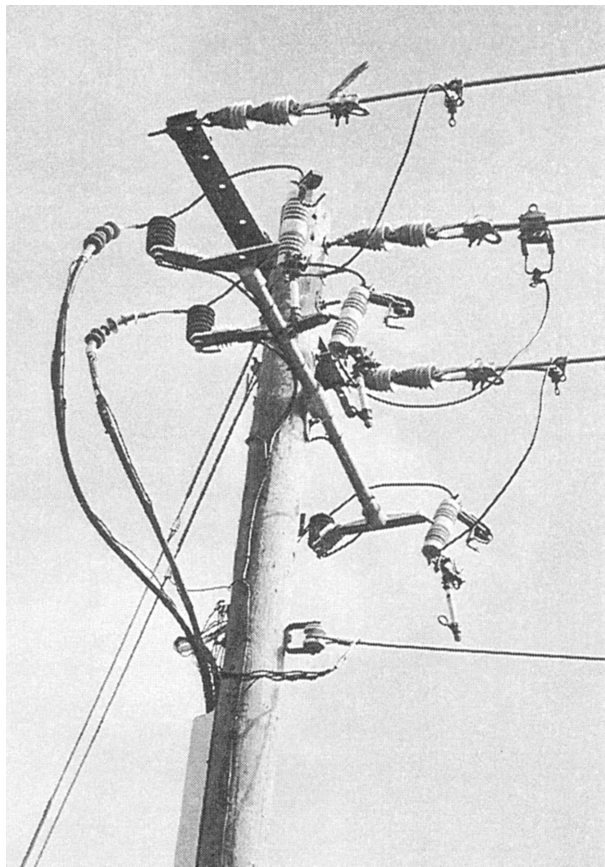

Figure 4-46.—Riser pole for underground distribution circuit.

UNDERGROUND POWER CABLES

Underground cables have various types of insulation and sheaths. Because higher voltages generate more heat, the amount of voltage carried determines the composition of the insulation.

Cables rated at 15 kilovolts and below usually have rubber or varnished cambric insulation and a PVC or rubber sheath. Those rated at 600 volts to 425 kilovolts have oil-impregnated paper insulation and a PVC sheath.

Cables rated at 5 kilovolts and above have metallic tape shields between the insulation and sheath for mechanical protection. Exceptions to this requirement are for single-conductor (1/0) cable with a PVC sheath and three-conductor (3/0) belted type of cable.

Much of the new cable being installed is cross-linked-polyethylene (XLP) or ethylenepropylene rubber (EPR). These are called solid type of insulations. The size and number of conductors in the cable depend on the job requirements.

UNDERGROUND COMMUNICATIONS CABLES

The most common types of underground communications cables in use today are steel-armored with plastic insulation (STELPATH), plastic-insulated with aluminum armor (PIC), and the new shielded fiber-optic cables.

PULLING CABLE

When installing a new run of duct, you pull in “pulling wire,” usually a lo-gauge iron wire. With this wire, you pull in a wire rope to which you attach the cable for pulling in.

Sometimes, when the duct has been in the ground a long time, the original iron pulling wire may be rusted so that it is not strong enough to pull the wire rope through. Also for a 400- to 500-foot run, it would be difficult to push a fish tape through the duct. The job can be simplified by using an air compressor to blow a chalk line cord through the duct. To do this, take a small cloth and tie the chalk line end to the four comers, so the cloth functions like a small parachute.

With the air hose in the end of the duct and the cord free to run out, you will be able to blow the cloth through to the next opening, even on a long run of duct.

Cleaning ducts is accomplished by rodding. Quick-coupling duct rods (about 1 feet long and 1 inch in diameter) are connected together with a wire brush or other duct rod leader at the head to facilitate cleaning. The rods may be pushed through manually or by means of power equipment. A 12-gauge galvanized steel wire attached to the leader is left in the duct for the cable pulling crew.

Moisture inside a cable causes deterioration of the insulation; therefore, precautionary measures should be taken to avoid the accumulation of moisture inside the cables. Before pulling a cable, ensure that the cable ends are sealed against moisture invasion.

RIGGING

Figure 4-47 shows a number of ways to rig manholes for cable pulling. View A shows the cable pulley attached to a timber block which, in turn, is supported by a wedge. In view B, the pulley is shown attached to the manhole wall by means of an embedded eye. If you use this method, make sure that the lower sheave is in line and level with the duct in which the cable is to be pulled. To prevent injury, to the cable by sharp edges, line the duct mouth with a shield.

Either of the above methods will probably be satisfactory for most of the jobs you will handle. Sometimes, however, more complex rigging is called for, especially in cases when the cable requires heavy pulling. For jobs of this nature, you will find the other views in figure 4-47 helpful.

When pulling cables into a long duct, use a feeding tube or bell for applying a lubricant at the duct mouth. Make sure you use the lubricant specified by the manufacturer of the cable.

Make a plank runway to support the reel for movement over areas where dirt, cinders, or crushed stone might damage the cable. All cable reels are marked with an arrow, indicating the direction in which they must be rolled. Comply with this arrow when placing the reel at a manhole so that it turns in the proper direction as cable is pulled from the reel. Place the reel as near as practical to the manhole and raise it on reel jacks just enough to clear the ground. Figure 4-48 shows a reel in proper position over the manhole so that the bend in the cable is not reversed as the cable is unreeled. Notice the scuff boot at the edge

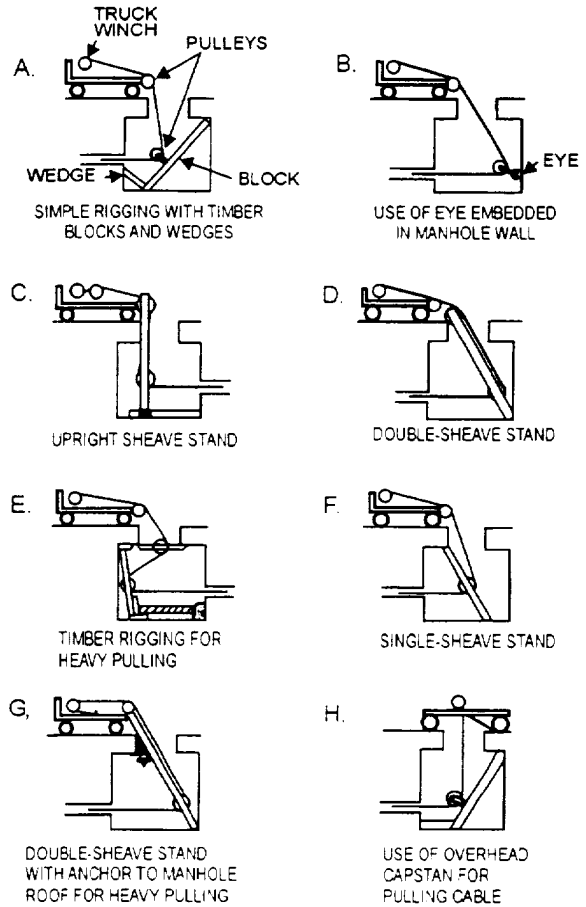

CE1f0447

Figure 4-47.—Manhole rigging for pulling cables.

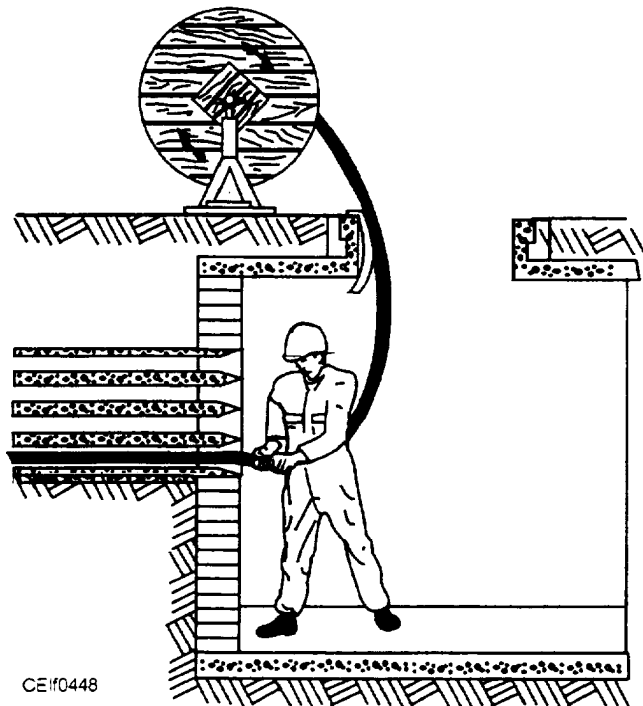

CE1f0448

Figure 4-48.—Reel in proper position.

of the manhole to prevent damage to the cable sheath. A section of an old tire casing can serve as a protective boot for this job.

The boards nailed to the two edges of the reel are called lagging. When the reel is in place, remove the lagging. You must be careful not to damage the cable when you pry the lagging loose. Be sure to remove any projecting nails from the edge of the reel before starting to remove the cable. Next, you must release the end of the cable from the reel, and you will then be ready for the main part of the job.

CABLE INSTALLATION

Assume that the winch line has been drawn into the duct, as the test line was pulled out. A basket grip is now attached to the end of the underground cable on the reel. The end of the basket is secured to the cable with a tight wrap of tape or wire. A swivel connection is necessary between the basket and the pulling cable to relieve twisting of the rope.

If the cable reel is within sight of the winch, it will take four people, in addition to the winch operator, to do the job safely. One person attends the reel to see that the cable rolls off the reel properly. Another in the manhole guides the cable into the duct. Both inspect the cable as it unreels and immediately signal “stop pulling” when a defect appears so that a closer inspection can be made for possible damage to the sheath. A third, stationed in the other manhole at the pulling end, signals “stop pulling” when the cable appears. The fourth crew member, aboveground at the pulling-end manhole, relays signals to the winch operator. This procedure enables the winch operator to concentrate on his job of seeing that the winch line is wound onto the reel properly.

The speed for pulling cable into a duct varies with the length of the duct and cable sizes. A single cable can be pulled in successfully at 75 feet per minute in a clear, straight duct. When you are handling more than one cable, reduce the speed to about 20 to 25 feet per minute, so you can prevent the conductors from crossing as they enter the duct.

When the “stop pulling” signal is given, make sure there is sufficient slack in both manholes for splicing or terminating the cable. The slack can be adjusted with the cable basket grip. Exercise care to prevent injury to the cable insulation. Remove the binding tape and the basket grip from the cable. The cable is then cut to the desired length and the cutoff end in the manhole is sealed unless splicing is done immediately. The end

of the cable remaining on the reel also must be sealed. In addition, check the seal on the end of the cable that has traveled through the duct, and reseal it if it has been broken from the strain.

DANGEROUS GASES

Gases may be dangerous for several reasons. The gas concentration may be explosive if it is made up of methane, sewer gas, natural gas, concentrations of spilled gasoline, or other liquid fuel vapors. As a general rule, these gases are heavier than air and will concentrate in low areas, such as manholes and ducts. They will remain there until they are dispersed. These gases are toxic as well as explosive. Other toxic gases are chlorine, ammonia, and a variety of the sulfide combinations. Other gases deplete the oxygen in the manholes and duct systems. Lack of oxygen can be as deadly as either the explosives or toxic gases. For these reasons, underground structures must be tested before workers enter them. Figure 4-49 shows two common types of test sets used for identifying carbon monoxide and combustible gases. View A shows a carbon monoxide tester and view B, an explosimeter. Only personnel who are specifically trained and certified may conduct tests for safe entry. Before entering any underground structures the base confined space manager or the assistant must certify the area safe for entry.

MAINTENANCE

Test equipment is essential for satisfactory power system operation. Meters are needed to monitor system operation conditions and also to check equipment before and after placing it in service. Periodic checks are necessary to ensure that the equipment remains in proper operating condition.

BASIC MEASURING INSTRUMENT PRECAUTIONS

When using measuring instruments, you must observe certain precautions. For example, it is especially important to be careful in using an ammeter because of its low internal resistance. If mistakenly placed across a voltage source, the meter can be damaged. Always break the circuit and **CONNECT AN AMMETER IN SERIES** with one meter lead going to each point of the circuit breaker to measure an unknown quantity. Be sure to de-energize the circuit before making or breaking the connections.

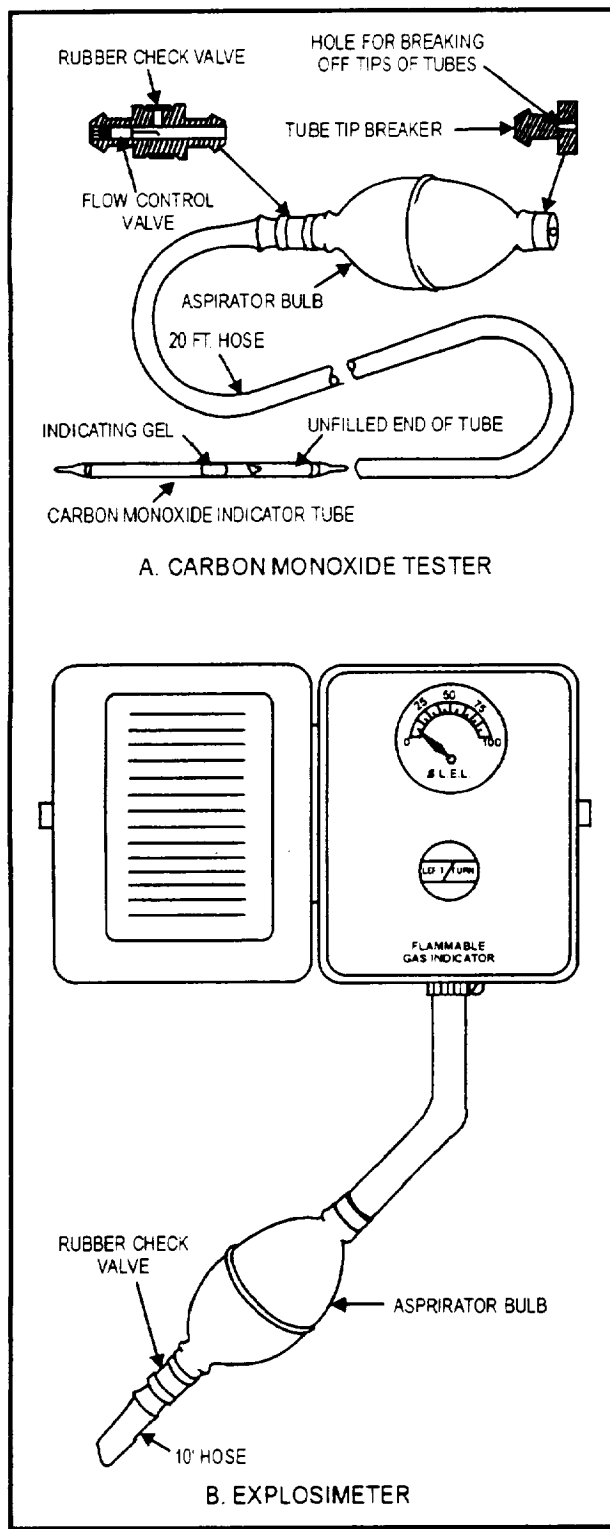

CE1f0449

Figure 4-49.—Underground gas-testing apparatus.

When using either ammeters or voltmeters: **ALWAYS** start at the **HIGHEST** meter range. Then drop down to a lower scale range if necessary. This practice protects the meter from injury if an attempt is made to read a high value in a low range. Damage to instruments also can be minimized if you form a habit

of placing the range selector switch in the highest range position after you have finished using the instrument.

OBSERVE POLARITY on all direct-current measurements. Take care to connect the positive terminal of the source to the positive terminal of the meter and the negative terminal of the source to the negative terminal of the meter. This action ensures that the meter polarity matches the polarity of the circuit in which the meter is placed.

Be careful to avoid dropping a meter or subjecting it to excessive mechanical shock. Such treatment may damage the delicate mechanism or cause the permanent magnet to lose some of its magnetism.

Care must be taken to avoid connecting the ohmmeter across circuits in which a voltage exists, since such connection can result in damage to the instrument. **TO ENSURE THE REMOVAL OF ALL VOLTAGE TO THE EQUIPMENT UNDER TEST, DISCONNECT THE SOURCE OF THE INPUT VOLTAGE BY REMOVING THE POWER PLUG.** Furthermore, **ALL CAPACITORS MUST BE DISCHARGED** before the ohmmeter prods are connected in the circuit. Charges remaining on capacitors after the applied voltage has been removed can severely damage the instrument.

Always turn ohmmeters **OFF** when finished. This action will avoid discharge of the internal battery if the test leads are shorted inadvertently.

It is important that you remember to **USE A LOW-VOLTAGE MEGGER TO TEST LOW-VOLTAGE INSULATION.** Application of high voltage may initiate insulation breakdown. low-voltage meggers should not be used to test high-voltage insulation because an inaccurate reading may result from the comparatively small output voltages available from this instrument. Be careful whether using high or low range meggers. Dangerous voltages exist at meter terminals and leads.

DIGITAL MULTIMETERS

There are a lot of different types and styles of autoranging digital multimeters that are designed for the professional at work in the field. These instruments stand up to the use and abuse of everyday service and electrically insulate the user from potential shock hazards. They have electronic overload protection against accidental application of voltage to resistance and continuity circuits. These characteristics,

combined with their rugged construction, make them durable and reliable instruments.

The maintenance and cleaning of these instruments are easy. Maintenance consists of periodic cleaning, battery replacement, fuse replacement, and recalibration. Calibration on these meters should be performed every year. The exterior of the instrument can be cleaned with a soft, clean cloth to remove any oil, grease, or grime from the exterior of the instrument. Never use liquid solvents or detergents. If the instrument gets wet for any reason, dry the instrument using low-pressure “clean” air at less than 25 psi. Use care and caution while drying around the display protector and areas where water or air could enter the interior of the instrument.

CAUTION

All resistance measurements should be taken on de-energized circuits ONLY!

WARNING

When using compressed air for cleaning, wear chemical splash goggles. Do not direct the air toward eyes or skin.

MAINTENANCE OF DISTRIBUTION EQUIPMENT

The elements, accidents, and willful vandalism are the cause of most damage to power distribution equipment. To repair these damages, the lineman requires experience, a total commitment to safety, and the knowledge to accomplish repairs to the system as quickly and economically as possible.

The maintenance required on the poles, timbers, and crossarms in a power distribution system is minimal. Normally, this equipment lasts for a period of 20 years or more. However, the following problems may occur and create a need for maintenance action:

- A pole can settle and require straightening.
- Wood can shrink and cause all hardware to become loose and require tightening.
- Over time, guys stretch and require re-tensioning.
- Insulators get dirty and require cleaning, especially around sea water where there is salt in the air.

- Connections become loose with age and must be re-torqued to prevent hot spots.
- In time, conductors stretch and require re-sagging.

INTERFERENCE ELIMINATION

Another important area of maintenance is noise interference elimination in the power distribution system.

Power lines may be a source of interference with radio communications. Conductors, insulators, and hardware contribute their share by means of spark discharges, localized corona discharge, and cross modulation.

Spark Discharges

Spark discharges occur when localized excessive voltage stress exists. A conductor may become partially insulated by corrosion products or an insulator partially conductive because of cracks. A third source of stress occurs when a conductor is separated from another metallic part on a pole only by a small air gap.

Corona Discharge

“Corona” is defined as the luminous discharge due to ionization of the air in the vicinity of a conductor when the voltage gradient exceeds a certain critical value.

Cross Modulation

Cross modulation (often the result of a corroded connection that causes nonlinear rectification of currents) may occur when splices are made by twisting the conductors, rather than using a tighter mechanical splice. Additionally, when conductors of dissimilar metals are joined, corrosion occurs unless special connectors designed for the specific combination of metals are used.

Remedies for conductor, insulator, and hardware interference are relatively simple. Remember, the condition for hardware interference is set up whenever two pieces of hardware are not securely bonded to each other or are permanently separated by too short an air gap.

DISTRIBUTION SAFETY EQUIPMENT

As the project supervisor or crew leader, you must review the work plan with all linemen before the start of the project. This conference lets all crew members know what their responsibilities are and what protective equipment and correct tools will be needed to safely and efficiently complete the assignment. Some of the most common pieces of safety equipment that you may use to ensure that your project is completed without incident are described below.

Rubber Gloves

The most important article of protection for a lineman or a cableman is a good pair of rubber gloves with the proper dielectric strength for the voltage of the circuit to be worked on. Leather protector gloves always must be worn over the rubber gloves to prevent physical damage to the rubber while work is being performed. When the rubber gloves are not in use, they should be stored in a canvas bag to protect them from mechanical damage or deterioration from sunrays. Rubber gloves always should be given an air test by the lineman or cableman each day before the work is started or whenever the workman encounters an object that may have damaged the rubber gloves.

The American National Standards Institute standard ANSI/ASTM D120, *Rubber Insulating Gloves*, covers lineman's rubber glove specifications.

The proof-test voltage of the rubber gloves should not be construed to mean the safe voltage on which the gloves can be used.

The maximum voltage on which gloves safely can be used depends on many factors including the care exercised in their use; the care followed in handling, storing, and inspecting the gloves in the field; the routine established for periodic laboratory inspection and test; the quality and thickness of the rubber; the design of the gloves; and other factors such as age, usage, and weather conditions.

Inasmuch as gloves are used for personal protection and a serious personal injury may result if they fail while in use, an adequate factor of safety should be provided between the maximum voltage on which they are permitted to be used and the voltage at which they are tested.

Rubber insulating gloves should be thoroughly cleaned, inspected, and tested regularly by competent personnel.

Rubber Sleeves

While a lineman is working on high-voltage distribution circuits, rubber sleeves should be worn with rubber gloves to protect the arms and shoulders of the lineman. Rubber insulating sleeves must be treated with care and inspected regularly, by the linemen in a manner similar to that described for rubber insulating gloves.

The rubber insulating sleeves should be thoroughly cleaned, inspected, and tested regularly by competent personnel.

Rubber Insulating Line Hose

Primary distribution conductors can be covered with rubber insulating line hose to protect the lineman from an accidental electrical contact (fig. 4-50). The line hoses are manufactured in various lengths with inside-diameter measurements that vary from 1 to 1 1/2 inches and must be tested to meet the required line voltage. The lineman should be sure that the voltage rating of the line hose provides an ample safety factor for the voltage applied to the conductors to be covered.

All line hoses should be cleaned and inspected regularly. A hand crank wringer can be used to spread the line hose to clean and inspect it for cuts or corona damage.

The rubber insulating line hose should be tested for voltage according to the specifications at scheduled intervals.

In-service care of insulating line hose and covers is specified in ANSI/ASTM D1050 standard.

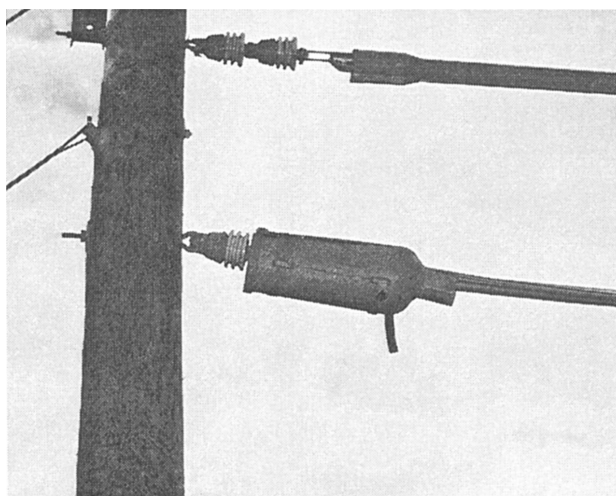

Figure 4-50.—Rubber insulating line hose used to cover primary conductors.

Rubber Insulating Insulator Hoods

Pin type or post type of distribution primary insulators can be covered by hoods. The insulator hood properly installed will overlap the line hose, providing the lineman with complete shielding from the energized conductors.

Insulator hoods, like all other rubber insulating protective equipment, must be treated with care, kept clean, and inspected at regular intervals. Canvas bags of the proper size attached to a handline should be used to raise and lower the protective equipment when it is to be installed and removed.

Conductor Covers

A conductor cover, fabricated from high-dielectric polyethylene, clips on and covers conductors up to 2 inches in diameter. A positive air gap is maintained by a swinging latch that can be loosened only by a one-quarter turn with a clamp stick.

Insulator Covers

Insulator covers are fabricated from high-dielectric polyethylene and are designed to be used in conjunction with two conductor covers. The insulator cover fits over the insulator and locks with a conductor cover on each end. A polypropylene rope swings under the crossarm and hooks with a clamp stick, thus preventing the insulator cover from being moved upward by bumping or wind gusts.

Crossarm Covers

High-dielectric-strength polyethylene crossarm covers are used to prevent tie wires from contacting the crossarm when conductors adjacent to insulators are being tied or untied. It is designed for single- or double-arm construction with slots provided for the double-arm bolts. Flanges above the slots shield the ends of the double-arm bolts.

Pole Covers

Polyethylene-constructed pole covers are designed to insulate the pole in the area adjacent to high-voltage conductors. The pole covers are available in various lengths. Positive-hold polypropylene rope

handles are knotted through holes in the overlap area of the cover.

Rubber Insulating Blankets

Odd-shaped conductors and equipment usually can be covered best with a rubber insulating blanket. The blankets, like other protective equipment, must receive careful treatment. The rubber insulating blankets are stored in canvas rolls or metal canisters to protect them when they are not in use. The blankets can be held in place by ropes or large wooden clamps.

In-service care of insulating blankets is specified in ANSI/ASTM D1048 standard.

Safety Hat

Hard hats, or safety hats, are worn by linemen, cablemen, and groundmen to protect the worker against an impact from falling or moving objects and against accidental electrical contact of the head and energized equipment. In addition, hard hats protect the worker from sunrays, cold, rain, sleet, and snow. The first combined impact-resisting and electrical-insulating hat was introduced in 1952. The hat was designed "to roll with the punch" by distributing the force of a blow over the entire head. This feature is accomplished by a suspension band which holds the hat about an inch away from the head and lets the hat work as a shock absorber.

The hard hat is made of fiber glass, or plastic material, and has an insulating value of approximately 20,000 volts. New helmets are manufactured to withstand a test of 30,000 volts without failure. The actual voltage that the hat will sustain while being worn depends upon the cleanliness of the hat, weather conditions, the type of electrode contacted, and other variables. The wearing of safety hats by linemen and cablemen has greatly reduced electrical contacts.

Physical injuries to the head have been practically eliminated as a result of workers on the ground wearing protective helmets. The Occupational Safety and Health Act of 1970 and most companies' safety rules require linemen, cablemen, and groundmen to wear safety hats while performing physical work. Specifications for safety hats are found in ANSI Standard Z89.1, *Protective Headwear for Industrial Workers-Requirements*.

CHAPTER 5

INTERIOR WIRING

INTRODUCTION

This chapter will help you understand the principles of interior wiring. The requirements for installing electrical systems are found in the current edition of the *National Electrical Code*[®] (NEC[®]). The requirements are specific and detailed, and they change somewhat as the complexity of the system increases. Therefore, the Code should be checked for proper installation of electrical systems.

INTERIOR SYSTEMS BELOW GRADE

An electrical system that is installed in concrete or in direct contact with the earth is considered to be a system below grade.

Below grade conduit layout and direct buried cable or other raceways must be installed to meet the minimum cover requirements of table 5-1. Under buildings, underground cables must be in a raceway that is extended beyond the outside walk of the building. Direct buried cables emerging from the ground will be in protected enclosures or raceways extending from the minimum cover distance, required by table 5-1, below grade to a point at least 8 feet above finished grade. There is no requirement for the protection of direct buried cables in excess of 18 inches below the finished grade.

Conduit in concrete buildings can be installed while the building is being erected. The outlets should be attached to the forms, and the conduits between outlets should be attached to reinforcing steel with metal tie wires so that the concrete can be poured around them. When several conduits pass through a wall, partition, or floor, a plugged sheet-metal tube should be set in the forms to provide a hole for them in the concrete. When a single conduit passes through a wall, partition or floor, a nipple or a plugged sheet-metal tube can be set in the forms.

Ferrous or nonferrous metal raceways, cable armor, boxes, cable sheathing, cabinets, elbows, couplings, fittings, supports, and support hardware may be installed below grade. These materials also may be installed in areas subject to severe corrosive

influences when made of material judged suitable for the condition or when provided with corrosion protection approved for the condition.

WET AND CORROSIVE INSTALLATIONS

Underground-feeder cable and branch-circuit cable provide an economical wiring system for wet and corrosive installations. Type UF two-conductor cable resembles Type USE service-entrance cable in general appearance. The insulation is a plastic compound. NEC[®] statements with respect to its use are as follows: Underground-feeder and branch-circuit cable may be used underground, including direct burial in the earth, as feeder or branch-circuit cable when provided with overcurrent protection not in excess of the rated current-carrying capacity of the individual conductors. If single-conductor cables are installed, all cables of the feeder circuit, subfeeder circuit, or branch circuit, including the neutral and equipment grounding conductor, if any, will be run together in the same trench or raceway. If the cable is buried directly in the earth, the minimum burial depth permitted is 24 inches if the cable is unprotected and 18 inches when a supplemental covering, such as a 2-inch concrete pad, metal raceway, pipe, or other suitable protection, is provided. Type UF cable may be used for interior wiring in wet, dry, or corrosive locations under the recognized wiring methods of the Code, and when installed as a nonmetallic-sheathed cable, it will conform with the provisions of the Code and be of a multiconductor type. Type UF cable also must be of a multiconductor type if installed in a cable tray.

Type UF cable will not be used (1) as service-entrance cable, (2) in commercial garages, (3) in theaters, (4) in motion-picture studios, (5) in storage-battery rooms, (6) in hoistways, (7) in any hazardous location, (8) embedded in poured cement, concrete, or aggregate except as provided in the Code, and (9) where exposed to direct rays of the sun unless identified as sunlight-resistant.

MARKINGS

Ungrounded conductors are available as single or multiconductor cables. These cables are clearly marked to identify them as grounded and grounding

Table 5-1.—Minimum Cover Requirements for 0 to 600 Volts (Burial in Inches)

<p align="center">Minimum Cover Requirements, 0 to 600 Volts, Burial in Inches</p> <p>Cover is defined as the shortest distance measured between a point on the top surface of any direct-buried conductor, cable, conduit or other raceway and the top surface of finished grade, concrete, or similar cover.</p>					
Type of Wiring Method or Circuit					
Location of Wiring Method or Circuit	See Note 1 Direct Burial Cables or Conductors	See Note 2 Rigid Metal Conduit or Intermediate Metal Conduit	See Note 3 Rigid Nonmetallic Conduit Approved for Direct Burial Without Concrete Encasement or Other Approved Raceways	See Note 4 Residential Branch Circuits Rated 120 Volts or Less with GFCI Protection and Maximum Overcurrent Protection of 20 Amperes	See Note 5 Circuits for Control of Irrigation and Landscape Lighting Limited to Not More than 30 Volts and Installed with Type UF or in Other Identified Cable or Raceway
All locations not specified below	24	6	18	12	6
In trench below 2-inch thick concrete or equivalent	18	6	12	6	6
Under a building	In raceway only	Not used	Not used	In raceway only	In raceway only
Under minimum of 4-inch concrete exterior slab with vehicular traffic and the slab extends not less than 6 inches beyond the underground installation	18	4	4	4 inches for raceway and 6 inches for direct burial	4 inches for raceway and 6 inches for direct burial
Under Streets, highways, roads, alleys, driveways, and parking lots	24	24	24	24	24
One and two family dwelling driveways, parking areas, and other purposes	18	18	18	12	18
In or under airport runways including adjacent areas where trespassing prohibited	18	18	18	18	18

Table 5-1.—Minimum Cover Requirements for 0 to 600 Volts (Burial in Inches)—Continued

In solid rock where covered by minimum of 2 inches concrete extending down to rock	2 inches, raceway only	2	2	2 inches, raceway only	2 inches, raceway only
<p>Note 1. For SI units; one inch = 25.4 millimeters.</p> <p>Note 2. Raceways approved for burial only where concrete encased will require concrete envelope not less than 2 inches thick.</p> <p>Note 3. Lesser depths are permitted where cables and conductors rise for terminations or splices or where access is otherwise required.</p> <p>Note 4. Where one of the conduit types listed in columns 1 through 3 is combined with one of the circuit types in columns 4 and 5, the shallower depth of burial is permitted.</p>					

conductors. Ungrounded conductors will be distinguished by colors other than white, natural gray, or green, or by a combination of color plus distinguishing marking. Distinguishing markings also will be in a color other than white, natural gray, or green, and will consist of a stripe or stripes or a regularly spaced series of identical marks. Distinguishing markings will not conflict in any manner with the surface markings required by the NEC®.

UNDERFLOOR RACEWAY SYSTEMS

Underfloor raceway systems are used in office buildings for the installation of the wiring for telephone and signal systems and for convenience outlets for electrically operated office machinery. They provide a flexible system by which the location of outlets may be changed easily to accommodate the rearrangement of furniture and partitions. The NEC® allows their use when embedded in concrete or in the concrete fill of floors. Their installation is allowed only in locations that are free from corrosive or hazardous conditions. No wires larger than the maximum size approved for the particular raceway will be installed. The voltage of the system must not exceed 600 volts. The total cross-sectional area of all conductors in a duct must not be greater than 40 percent of the interior cross-sectional area of the duct.

An underfloor raceway system consists of ducts laid below the surface of the floor and interconnected by means of special cast-iron floor junction boxes. The ducts for underfloor raceway systems are made of either fiber or steel. Fiber ducts are made in two types—the open-bottom type and the completely enclosing type. Steel ducts are always of the

completely enclosing type, usually having a rectangular cross section. In the underfloor raceway system, provision is made for outlets by means of specially designed floor-outlet fittings that are screwed into the walls of the ducts. When fiber ducts are used, the duct system is laid in the floor with or without openings or inserts for outlets. After the floor has been poured and finished as desired, the outlet fittings are installed into inserts or at any points along the ducts at which outlets are required. The method of installing outlet fittings is described in the next paragraph. When steel ducts are used, provision for the outlet fittings must be made at the time that the ducts are laid before the floor or floor fill is poured. The steel ducts are manufactured with threaded openings for outlet connections at regularly spaced intervals along the duct. During the installation of the raceway and the floor, these outlet openings are closed with specially constructed plugs whose height can be adjusted to suit the floor level. For telephone and similar circuits, much wider ducts can be obtained.

In general, underfloor raceways should be installed so that there is at least 3/4 inch of concrete or wood over the highest point of the ducts. However, in office-approved raceways, they may be laid flush with the concrete if covered with linoleum or equivalent floor covering. When two or three raceways are installed flush with the concrete, they must be contiguous with each other and joined to form a rigid assembly. Flat-top ducts over 4 inches wide but not over 8 inches, spaced less than 1 inch apart, must be covered with at least 1/2 inch of concrete. It is standard practice to allow 3/4-inch clearance between ducts run side by side. The center line of the ducts should form a

straight line between junction boxes. If the spacing between raceways is 1 inch or more, the raceway may be covered with only 1 inch of concrete. All the joints in the raceway between sections of ducts and at junction boxes should be made waterproof and have good electrical contact so that the raceways will be electrically continuous. Metal raceways must be properly grounded.

To establish outlets in a preset system after the finish is in place, you have to determine the location of the insert. Inserts can be located by using an insert finder. Once inserts are located, the flooring is chipped down to expose the insert cap. The cap is removed and a hole cut in the duct so the wires can be fished through and connected to the receptacle.

The following procedures should be used to install an outlet fitting at any point in a completely enclosed underfloor fiber raceway:

1. Locate the duct line.
2. Cut a hole in linoleum or other floor covering.
3. Chip a hole down to duct.
4. Cut a hole in the duct.
5. Screw insert into the duct.
6. Anchor the insert with grouting compound.
7. Screw the outlet into the insert.

The special tools, provided by the manufacturer, for this purpose should be used to ensure satisfactory workmanship.

Combination junction boxes accommodating the two or three ducts of multiple-duct systems may be used, provided separate compartments are furnished in the boxes for each system. It is best to keep the same relative location of compartments for the respective systems throughout the installation.

All the joints in or taps to the conductors must be made in the junction boxes. No joints or taps should be made in the ducts of the raceway or at outlet insert points.

INTERIOR SYSTEMS ABOVE GRADE

An interior system above grade starts at the service drop and covers all the conduit layouts (excluding in-the-slab), communication, power, and lighting circuits. You must be aware of the NEC[®] rules that govern industrial and residential interior electrical systems. To gain additional knowledge, you may read

the following: *Standard Handbook for Electrical Engineers* and the *American Electrician's Handbook*.

CONDUIT LAYOUT

Follow the construction blueprints and specification when laying out conduit runs. Remember, most prints will not show the direction of the conduit run. They only direct you to install a circuit from the distribution panel to a location where a electrical apparatus will be serviced. When you install any circuit, complete the service installation with the shortest route possible.

Properly bent conduit turns look better than elbows and, therefore, are preferable for exposed work (fig. 5-1). If bends are formed to a chalk line, draw the chalk line as suggested in figure 5-2. The conduits can

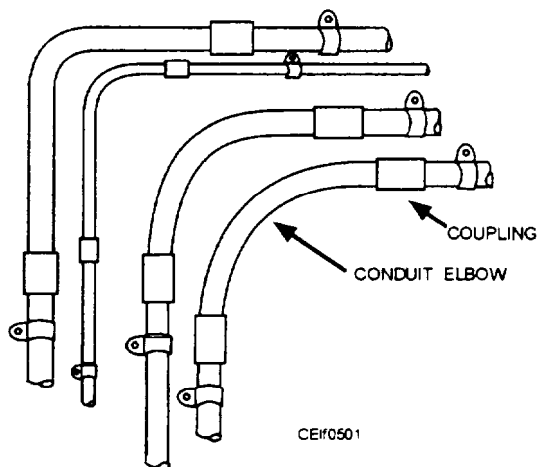

Figure 5-1.—Right-angle turns with elbows.

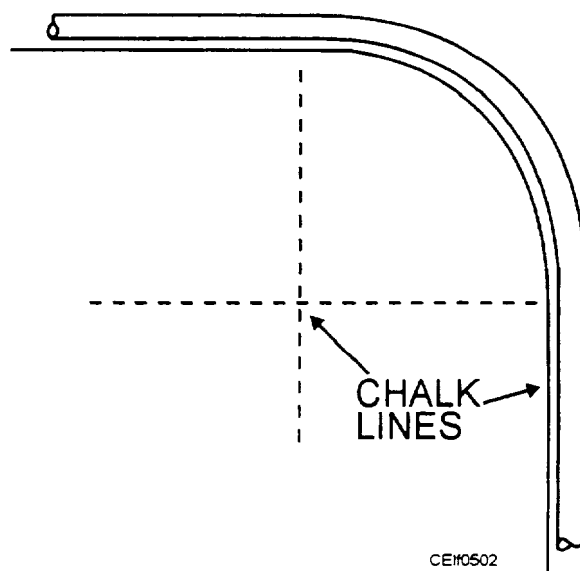

Figure 5-2.—Forming a conduit to chalk lines.

be placed parallel at a turn in a multiple run, as shown in figure 5-3. If standard elbows are used, it is impossible to place them parallel at the turns. They will have an appearance similar to the one shown in figure 5-1.

Except as discussed in the NEC[®], metal raceways, cable armor, and other metal enclosures for conductors will be joined together into a continuous electric conductor and will be connected to all the boxes, fittings, and cabinets to provide effective electrical continuity. Raceways and cable assemblies will be mechanically secured to boxes, fittings, cabinets, and other enclosures. This action ensures electrical continuity of metal raceways and enclosures.

WIRING OF BUILDINGS

Normally the power-distribution feeder from the power pole to a building is secured to the building with an insulator bracket. Brackets should be mounted high enough so the power feeders are never suspended lower than 18 feet over driveways and 10 feet over walkways.

Insulator bracket service-entrance conductors run down the side of the building to a point where they enter the building and connect to the service-entrance panel. For commercial and industrial wiring, the greatest percentage of wiring will be installed in a

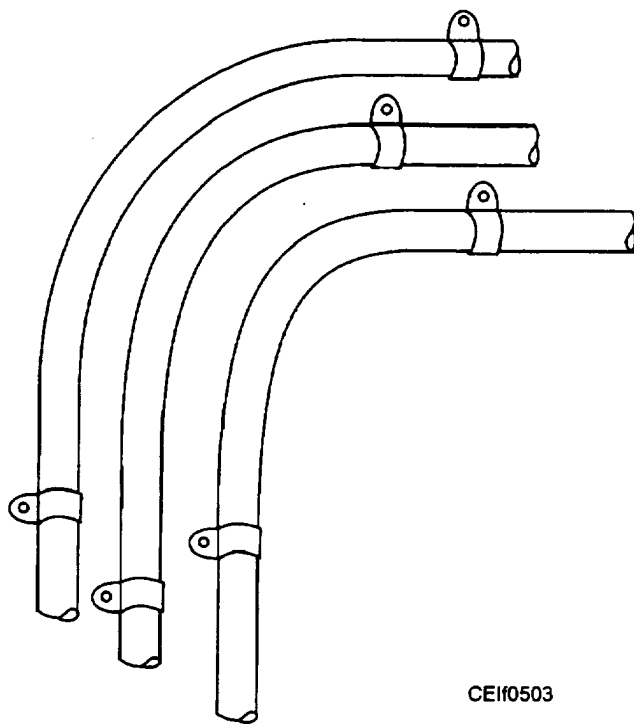

Figure 5-3.—Right-angle turns with bent conduit.

conduit or a raceway. Service-entrance cable should be used for this purpose.

Armored cable or nonmetallic-sheathed cable should be used for the interior wiring of the building.

GROUNDING

At each building, the wiring system must be grounded. This provision is in addition to the ground at the power pole. Grounds must be established at each point of entrance to each building; and, if possible, all these grounds should be tied together on driven grounds. Also, for added safety, the water system should be tied at each building to the driven ground for that building. A well-grounded wiring system adds to the safety of the entire installation.

WIRING SYSTEM GENERAL PROVISIONS

The following discussion applies to the types of wiring used for voltages up to 600 volts, unless otherwise indicated. Each type of insulated conductor is approved for certain uses and has a maximum operating temperature. If this temperature is exceeded, the insulation is subject to deterioration. In recent years, modified ethylene tetrafluoroethylene (2 and ZW) and perfluoroalkoxy (PFA and PFAH) cables have been allowed for high-temperature operations. Each conductor size has a maximum current-carrying capacity, depending on the type of insulation and conditions of use.

Conductors of more than 600 volts should not occupy the same enclosure as conductors carrying less than 600 volts, but conductors of different light and power systems of less than 600 volts may be grouped together in one enclosure if all are insulated for the maximum voltage encountered. Communication circuits should not occupy the same enclosure with light and power wiring.

Boxes or fittings must be installed at all outlets, at switch or junction points of raceway or cable systems, and at each outlet and switch point of concealed knob-and-tube work.

PROVISIONS APPLYING TO ALL RACEWAY SYSTEMS

The number of conductors, permitted in each size and type of raceway, is definitely limited to provide ready installation and withdrawal. For conduit and electrical metallic tubing, refer to the NEC[®].

Raceways, except surface-metal molding, must be installed as complete empty systems, the conductors being drawn in later. Conductors must be continuous from outlet to outlet without splice, except in auxiliary gutters and wireways.

Conductors of No. 8 AWG and larger must be stranded. Raceways must be continuous from outlet to outlet and from fitting to fitting and will be securely fastened in place.

All conductors of a circuit operating on alternating current, if in a metallic raceway, should be run in one enclosure to avoid inductive overheating. If, owing to capacity, not all conductors can be installed in one enclosure, each raceway used should contain a complete circuit (one conductor from each phase).

Rigid-metal conduit, intermediate metal conduit, and electrical metallic tubing are the systems generally used where wires are to be installed in raceways. Both conduit and tubing may be buried in concrete fills or may be installed exposed. Wiring installed in conduit is approved for all classes of buildings and for voltages both above and below 600 volts. Certain restrictions are placed on the use of tubing; refer to the NEC®.

LIGHTING AND POWER SYSTEMS

Lighting and power systems start at the panelboards. Refer to the NEC® during the installation of the lighting and power circuits for further guidance. The wiring layout in each of these illustrations determines how the component parts in the circuit will be connected to one another and where the wires will be routed. Careful planning in the wiring layout can result in substantial savings by eliminating long runs of excess wire. It should be pointed out that the wire runs that are shown in the actual construction illustration may not be the most economical use of wire. These wire runs are laid out in a very smooth and definite pattern to make the drawing easier to follow. In many cases, wire runs shown at right angles should be run diagonally to conserve wire. When cable runs are routed on the jobsite, shortening the runs will result in lower installation costs.

SERVICES AND FEEDERS

No limit is placed on the electrical capacity of service conductors and service protection used in bringing the electric supply into a building, since only one supply should be introduced whenever possible. Near the point of entrance of the supply, the heavy-service conductors are tapped by feeders that conduct the electricity to panelboards at various load centers in

the building where the final branch circuits which supply individual lighting, heating, and power outlets originate. No limits are placed on the electrical capacity of feeders; but, for practical purposes, they are limited in size by the difficulty of handling large conductors and raceways in restricted building spaces, by voltage drop, and by economic considerations.

Each lighting fixture, motor, heating device, or other item of equipment must be supplied by either a branch circuit for grouped loads, by an individual branch circuit, or by a motor branch circuit.

LIGHTING AND APPLIANCE BRANCH-CIRCUIT PANELBOARDS

In solving all installation problems with panelboards, the first consideration is to determine whether the panelboard will be considered a lighting and appliance branch-circuit type. The NEC® rules are much stricter for lighting and appliance branch-circuit panelboards than for other types.

The Code defines a lighting and appliance branch-circuit panelboard as one having more than 10 percent of its overcurrent devices rated 30 amperes or less for which neutral connections are provided. For example, if any panelboard with less than 10 overcurrent devices contains one overcurrent device rated at 30 amperes for which neutral connections are provided, it would be considered a lighting and appliance branch-circuit panelboard ($1 \div 9 = 11\%$).

In another example, panelboards that supply loads without any neutral connections are not considered lighting and appliance branch-circuit types whether or not the overcurrent devices are 30 amperes or less.

When it is determined that a panelboard is a lighting and appliance branch-circuit type, the following NEC® rules apply:

1. Individual protection, consisting of not more than two main circuit breakers or sets of fuses having a combined rating not greater than that of the panelboard, is required on the supply side. This main protection may be contained within the panelboard or in a separate enclosure ahead of it. Two exceptions to the Code rule are as follows:

- a. Individual protection is not required when the panelboard feeder has overcurrent protection not greater than that of the panelboard. For example, two 400-ampere panelboards can be connected to the same feeder if the feeder overcurrent device is rated or set at 400 amperes or less.

b. Individual protection is not required where such existing panelboards are used as service equipment in supplying an individual residential occupancy. For example, take a split-bus panelboard in which the line section contains three to six circuit breakers or fuses, none of which are rated 20 amperes or less. In such an arrangement, one of the main overcurrent devices supplies the second part of the panel that contains 15- or 20-ampere branch-circuit devices. The other main overcurrent devices (over 20 amperes) supply feeders or major appliances, such as cooking equipment, clothes dryers, water heaters, or air-conditioning equipment (fig. 5-4). This arrangement is permitted only for existing panelboards in existing individual residential occupancies.

2. A lighting and appliance branch-circuit panelboard is limited to not over 42 overcurrent devices (excluding the main overcurrent devices) in any one cabinet or cutout box (fig. 5-5). When such devices are numbered, a single-pole circuit breaker is counted as one overcurrent device; a two-pole circuit breaker, as two overcurrent devices; and a three-pole circuit breaker, as three overcurrent devices.

In addition, the panelboards will be provided with physical means to prevent the installation of more overcurrent devices than the panelboard was designed, rated, and approved to handle. Figure 5-6 shows a suitable arrangement for overcurrent devices.

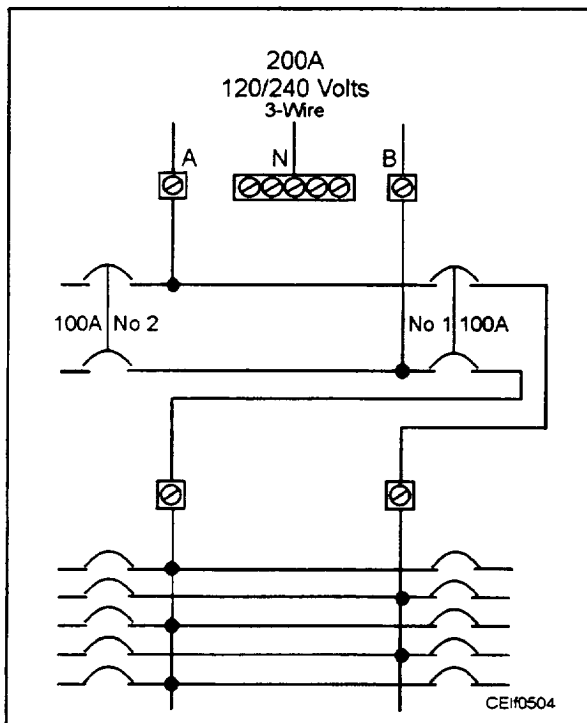

Figure 5-4.—Typical arrangement of a split-bus lighting panelboard.

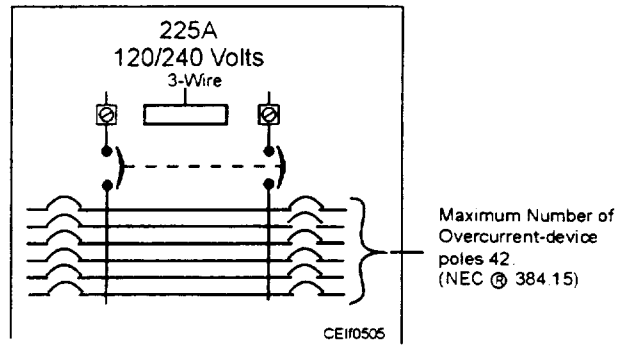

Figure 5-5.—Typical arrangement that shows NEC® rules for lighting panelboards.

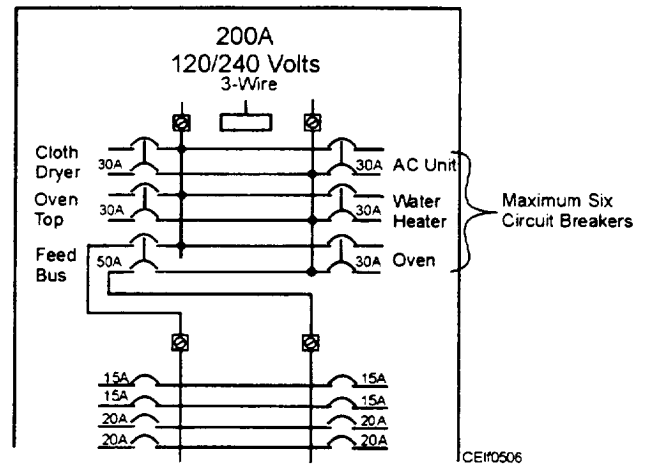

Figure 5-6.—Suitable arrangement for an existing 200-ampere lighting panelboard used as service equipment for individual residential occupancy.

A typical lighting panelboard is a circuit-breaker type with a main 200-ampere circuit breaker and thirty-two 20-ampere single-pole breakers. This type of panel is used for a four-wire, three-phase, grounded neutral system. The main breaker is three-pole.

Other NEC® provisions that apply to all types of panelboards are as follows:

1. Panelboards, equipped with snap switches rated 30 amperes or less, will have overcurrent protection not in excess of 200 amperes. Circuit breakers are not considered snap switches.

2. Panelboards that have switches on the load side of any type of fuse will not be installed except for use as service equipment. Panelboard equipment with the snap switch is on the line side of the plug fuses and satisfies the Code.

3. The total load on any overcurrent device, located in a panelboard, will not exceed 80 percent of its rating. If in normal operation, the load will be continuous (3 hours or more) unless the assembly including the overcurrent device is approved for continuous duty at 100 percent of its rating.

Power-distribution panels are similar to the feeder-distribution type. They have bus bars normally rated up to 1,200 amperes at 600 volts or less and contain control and overcurrent devices sized to match connected motor or other power circuit loads. Generally, the devices are three-phase.

Special panelboards, containing relays and contactors, can be obtained and installed when remote control of specific equipment is specified. A thorough knowledge of all the available types of panelboards aids in the selection and installation of the proper unit.

Service-equipment panelboards, for loads up to 800 amperes, containing six or fewer main fused switches, fused pullouts, or circuit breakers are available. These panels constitute service equipment and frequently contain split buses that supply branch circuit or feeder overcurrent devices installed in the same enclosure (figs. 5-4 and 5-6).

Feeder distribution panels generally contain circuit overcurrent devices rated at more than 30 amperes to protect subfeeders that extend to smaller branch-circuit panelboards.

BRANCH CIRCUITS FOR GROUPED LOADS

The uses and limitations of the common types of branch circuits are outlined in the Summary of Branch-Circuit Requirements (NEC[®] table 210-24). Lighting branch circuits may carry loads as high as 50 amperes, although florescent lighting is limited to use on circuits of 15-ampere or 20-ampere rating. Such circuits are extensively used in commercial and industrial occupancies. Branch circuits, supplying convenience outlets for general use in other than manufacturing areas, are usually limited to a maximum of 20 amperes. The type of outlet required for heavier capacity circuits usually will not accommodate the connection plug found on portable cords, lamps, motor-driven office machinery, and so forth.

INDIVIDUAL BRANCH CIRCUITS

Any individual piece of equipment (except motors) also may be connected to a branch circuit meeting the following requirements: Conductors must

be large enough for the individual load supplied. Overcurrent protection must not exceed the capacity of the conductors or 150 percent of the rating of the individual load if the single-load device is a nonmotor-operated appliance rated at 10 amperes or more. Only a single outlet or piece of equipment may be supplied.

MOTOR BRANCH CIRCUITS

Because of the peculiar conditions obtained during the starting period of a motor and because it may be subjected to severe overloads at frequent intervals, motors, except for very small sizes, are connected to branch circuits of a somewhat different design from that previously discussed.

CONDUCTORS

The Code covers general requirements for conductors and their type designations, insulations, markings, mechanical strengths, ampacity ratings, and uses. These requirements do not apply to conductors that form an integral part of the equipment, such as motors, motor controllers, and similar equipment, or to conductors specifically provided for elsewhere in the Code.

Conductors must be insulated except where covered or bare conductors are specifically permitted by the NEC[®]. The Code covers the insulation of neutral conductors of a solidly grounded high-voltage system. When stranded conductors are installed, the Code states that stranded conductors installed in raceways must be a size No. 8 or larger with the following exceptions:

Exception No. 1: When used as bus bars or in mineral-insulated, metal-sheathed cable

Exception No. 2: When bonding conductors are required

Conductors in Parallel

Aluminum, copper-clad aluminum, or copper conductors of size 1/0 and larger, in each phase of the current; neutral; and grounded circuit conductors may be connected in parallel (electrically joined at both ends to form a single conductor).

Exception No. 1: Conductors in sizes smaller than No. 1/0 AWG will be permitted to run in parallel to supply control power to indicating instruments, contactors, relays, solenoids, and similar control devices provided:

1. They are contained within the same raceway or cable

2. The ampacity of each individual conductor is sufficient to carry the entire load current shared by the parallel conductors
3. The overcurrent protection is such that the ampacity of each individual conductor will not be exceeded if one or more of the parallel conductors become inadvertently disconnected

Equipment Grounding Conductors

Bare, covered, or insulated grounding conductors will be permitted. Individually covered or insulated grounding conductors will have a continuous outer finish that is either green or green with one or more yellow stripes.

Exception No. 1: An insulated or covered conductor larger than No. 6 will be permitted, at the time of installation, to be permanently identified as a grounding conductor at each end and at every point where the conductor is accessible. Identification will be accomplished by one of the following means:

1. Stripping the insulation or covering from the entire exposed length
2. Coloring the exposed insulation or covering green

3. Marking the exposed insulation or covering with green colored tape or green colored adhesive labels

Exception No. 2: Where the conditions of maintenance and supervision assure that only qualified persons will service the installation, an insulated conductor in a multiconductor cable will be permitted, at the time of installation, to be permanently identified as a grounding conductor at each end and at every point where the conductor is accessible by one of the following means:

1. Stripping the insulation from the entire exposed length
2. Coloring the exposed insulation green
3. Marking the exposed insulation with green tape or green colored adhesive labels

The following paragraphs discuss conductors in vertical conduits. You may not work very much with multistory buildings but the knowledge is very important. Conductors in vertical conduits must be supported within the conduit system, as shown in table 5-2.

The following methods of supporting cables will satisfy NEC[®] requirements:

1. Approved clamping devices are constructed of or use insulated wedges inserted in the ends of the

Table 5-2.—Spacing of Vertical Conductors Support

CONDUCTOR SIZE	CONDUCTORS (IN FEET)	
	Aluminum or Copper-Clad Aluminum	Copper
	Not greater than	Not greater than
No. 18 through No. 8	100	100
No. 6 through No. 0	200	100
No. 00 through No. 0000	180	80
211,601 through 350,000 cmil	135	60
350,001 through 500,000 cmil	120	50
500,001 through 750,00 cmil	95	40
Above 750,000 cmil	85	35

conduits (fig. 5-7). With cables having varnished-cambric insulation, it also may be necessary to clamp the conductor.

2. Junction boxes may be inserted in the conduit system at required intervals. Insulating supports of an approved type must be installed in the junction boxes and secured in a satisfactory manner to withstand the weight of the attached conductors. The boxes must be provided with proper covers.

3. The cables may be supported in junction boxes by deflecting them (fig. 5-8) not less than 90 degrees and carrying them horizontally to a distance not less than twice the diameter of the cable. The cables may be carried on two or more insulating supports and additionally secured by tie wires. When this method is used, the cables will be supported at intervals not greater than 20 percent of those mentioned in the preceding table.

TESTING ELECTRICAL CIRCUITS

In this section, you will find out how easy it is to assist and train your crew in troubleshooting. Many

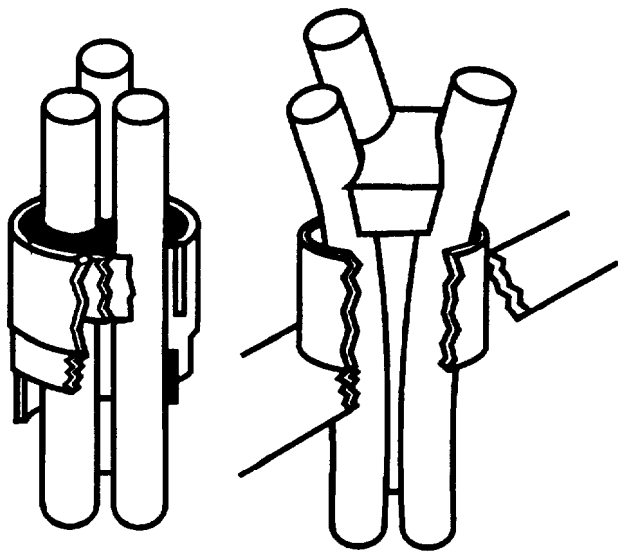

Remove pulling compound from wires. Place plug between the wires as close to the top of the body as possible. Where more than one conductor size is used, care should be taken to locate each wire in the proper groove.

CE110507

Figure 5-7.—Gable support screwed on the end of a conduit and the one piece plug type.

different types of electrical multimeters are available to assist you. Electrical circuits can be tested safely and inexpensively with a neon tester (fig. 5-9). Most electrical problems can be solved just by determining the presence or absence of voltage.

CHECKING FOR A DEFECTIVE RECEPTACLE

One of the most common tests made with a neon tester is determining whether a receptacle is providing power. Figure 5-10 shows the first step in testing a receptacle. Each lead of the tester is firmly pressed into the receptacle slots to form a good electrical contact.

If voltage is present, the neon tester will glow softly for a 110-volt circuit and more brightly for a 220-volt circuit. If the tester does not light, the receptacle cover should be removed so that a second voltage check can be made at the terminals of the receptacle (fig. 5-11). If voltage is present at the terminals but not at the receptacle, the receptacle is defective and should be replaced. If voltage is not present at either the receptacle or its terminals, the problem lies in the overload protection or in the electrical circuit leading to the troubled receptacle.

When the problem is in the electrical circuit leading to the receptacle, check each splice or each terminal point along the entire circuit for a break or a loose connection.

CHECKING FOR A DEFECTIVE SWITCH

Determining whether a switch is defective requires only a simple two-step procedure. You must determine whether voltage is reaching the switch and whether voltage is passing through the switch.

Figure 5-12 shows how you can position the neon tester to determine if voltage is reaching the switch. Figure 5-13 shows how you reposition the tester to determine if voltage is going through.

With a grounded system, you need only touch the metal box and the terminals (figs. 5-12 and 5-13), or you may find it necessary to remove the wire nut from the neutral wire and use the neutral as the other test point. If voltage is not present at either switch terminal, the problem lies in the overload protection or in the electrical circuit leading to the troubled switch.

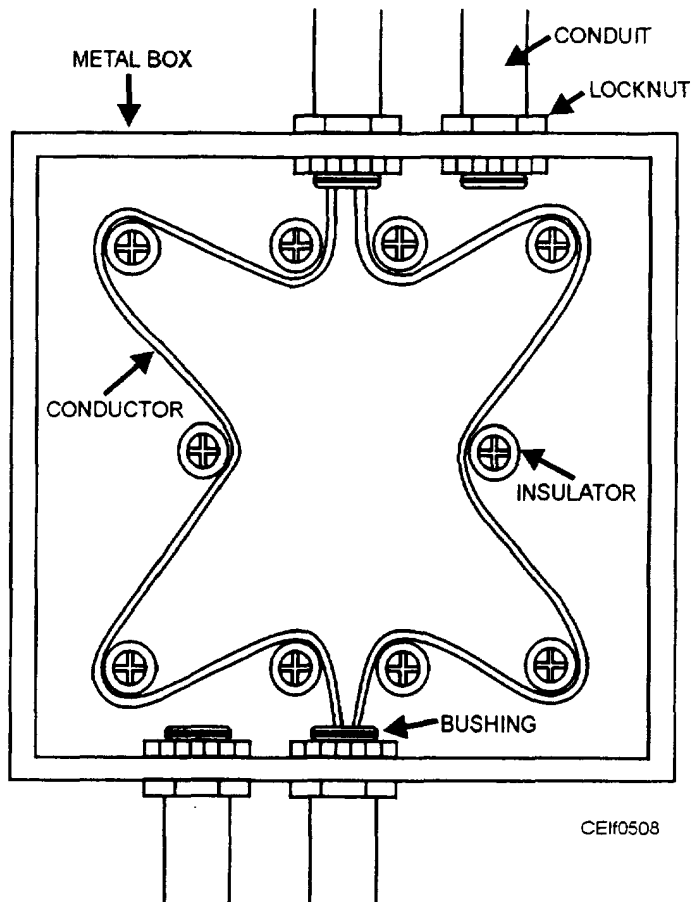

CEI10508

Figure 5-8.—Supporting conductors in a vertical conductor run.

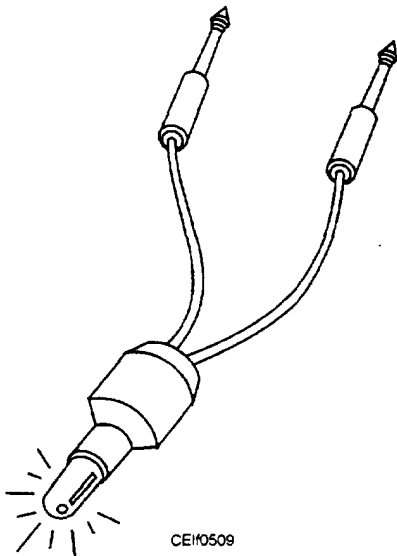

CEI10509

Figure 5-9.—Neon testers for 110/220-volt circuits.

When the problem is in the electrical circuit leading to the receptacle, each splice or terminal point should be checked along the entire circuit for a break or loose connection. Before this test procedure is started, be sure the power to the suspected switch has been turned OFF.

WARNING

Failure to secure power could result in a fatal electrical shock. More people are killed by normal household current than high voltage. When energized circuits are being worked on, the worker should be trained according to 29 CFR 1910.333 and use the protective equipment specified in 29 CFR 1910.335.

Remove the faceplate from the switch and unscrew the switch from the junction box. Pull the switch away from the metal box and position it so that no bare wires can touch the box. When the switch is in a SAFE position, power may be restored and the test procedure started.

CHECKING FOR THE HOT WIRE

In remodeling you may find it necessary to check which wires provide power to the circuit and which wires merely continue on to feed other circuits. The neon tester can simplify this procedure by individually

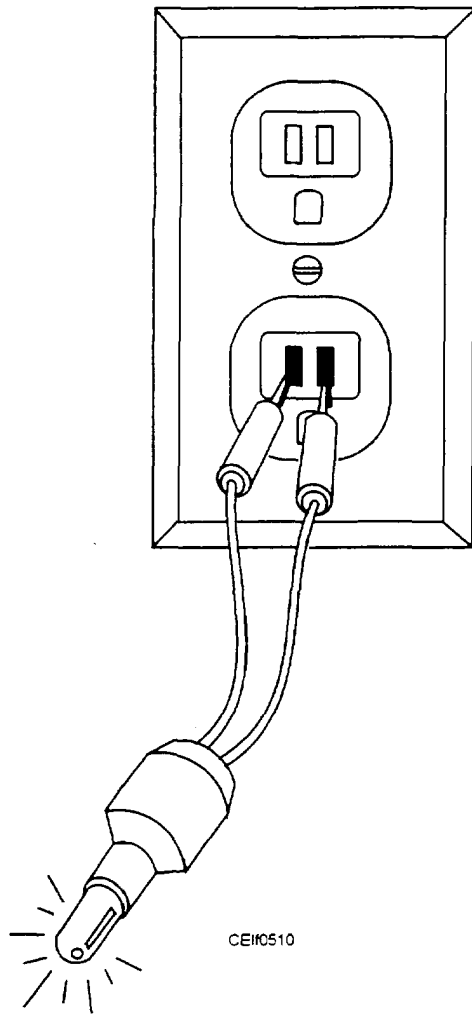

Figure 5-10.—First step in testing an outlet with a neon tester.

identifying each pair of wires. The pair that is hot will cause the neon tester to glow.

The grounded system is easiest to check because only the potential hot wires need to be disconnected, separated, and tested. Figure 5-14 shows how the wires are separated and tested. The wire that causes the neon tester to respond is the hot lead.

An ungrounded system can be checked just like a grounded system? except the solderless connector must be removed from the neutral wire and the neutral wire must be used as a reference, as shown in figure 5-15. Figure 5-16 shows how to determine if voltage is reaching a light fixture. With the switch in the ON position, the neon tester should light.

TESTING THE GROUND TERMINAL

A simple test procedure, as shown in figure 5-17, may be used to check each receptacle for ground.

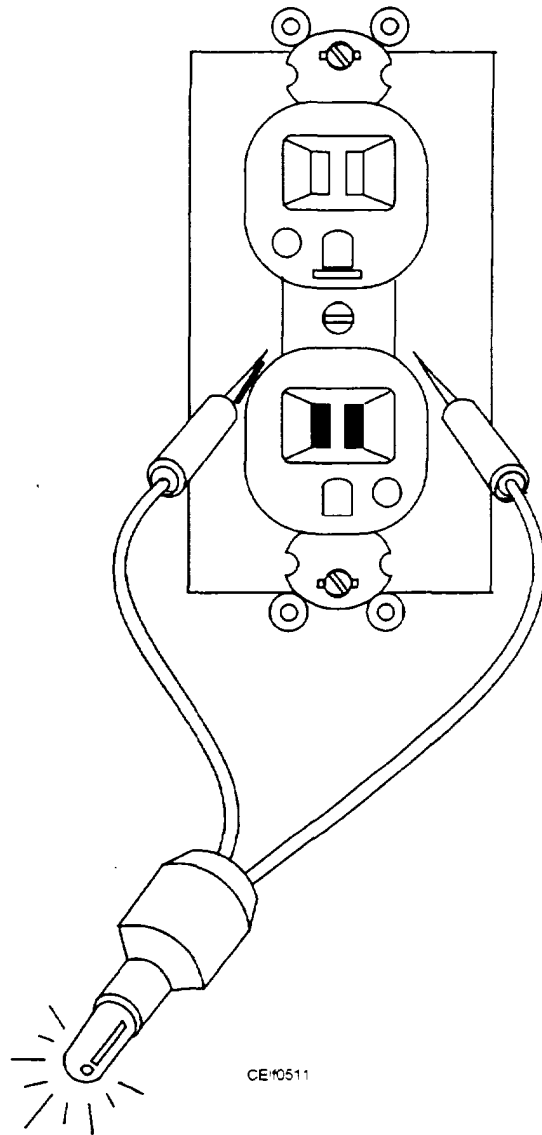

Figure 5-11.—Using the neon tester to check for a defective receptacle.

One lead of the neon tester should be held stationary on the ground terminal while the opposite lead is repositioned on each plug slot. If the receptacle is properly grounded, the neon light will light when placed in only one of the slots. If the light does not glow in either slot, the receptacle is not grounded.

TESTING CIRCUIT BREAKERS AND FUSES IN CIRCUITS

When you are troubleshooting large electrical systems, it is important to follow the systematic approach: localize, isolate, and locate. It is never a good procedure to make haphazard measurements in a system hoping that luck will lead to the problem. Testing circuit breakers and fuses in the circuit first may eliminate unnecessary troubleshooting. Practice

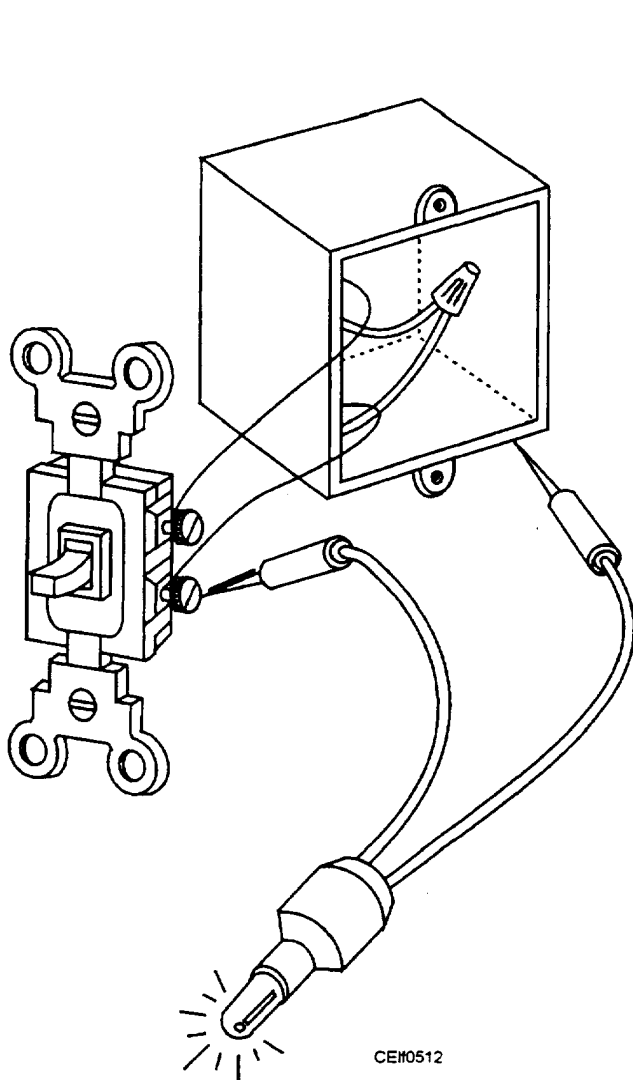

Figure 5-12.—Checking a switch in the OFF position for proper operation.

safe habits. Remember that getting too friendly with electricity can be a shocking experience.

Circuit Breaker

A circuit breaker operates much the same as a switch—the breaker is either ON or OFF. The neon tester lead is placed on the neutral bar and the other lead is placed on the screw terminal of the circuit breaker (fig. 5-18). If the breaker is good, the neon tester will light when the breaker is in the ON position and will not light when the breaker is in the TRIPPED position.

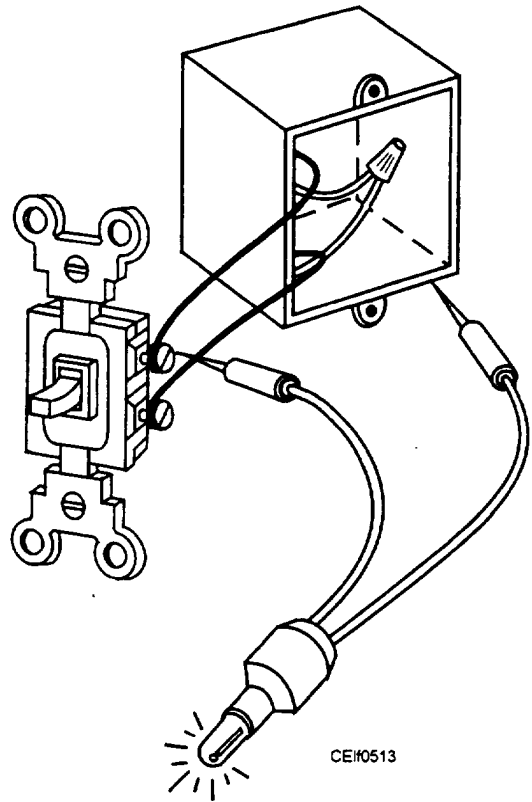

Figure 5-13.—Checking a switch in the ON position for proper operation.

If the neon tester remains lighted in both positions, the breaker is shorted and should be replaced. If the neon tester does not light in either position, the circuit breaker is open and should be replaced. Remember to reset the circuit breaker.

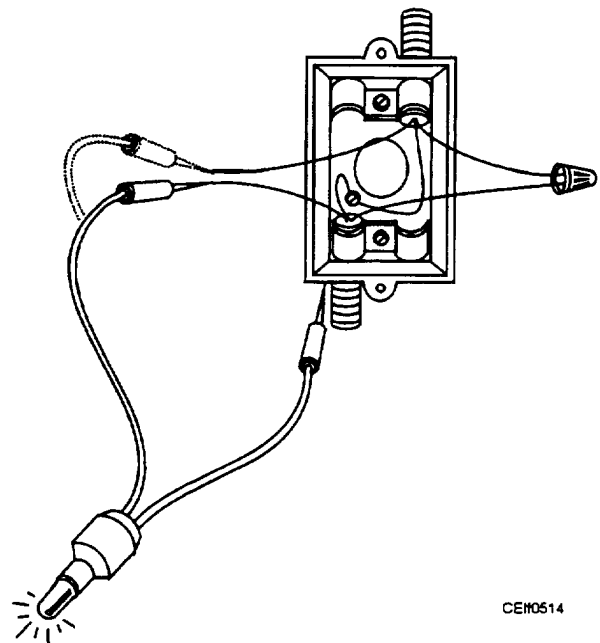
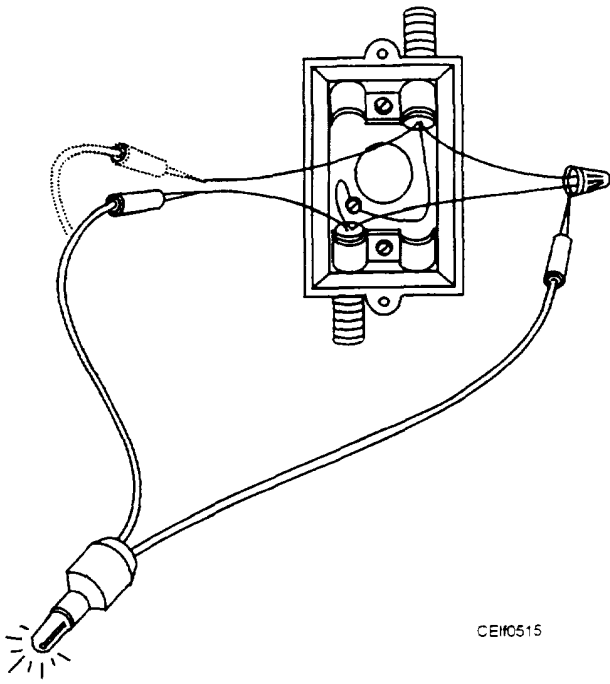
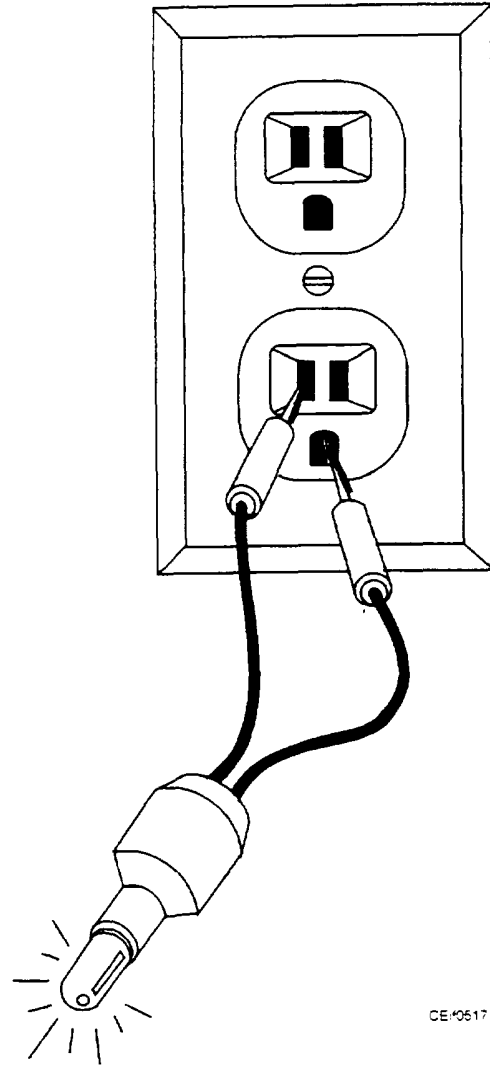

Figure 5-14.—Technique for determining which wire is hot.



CEI#0515

Figure 5-15.—Checking for the hot wire in an underground system with neutral wire exposed.



CEI#0517

Figure 5-17.—Checking for a properly grounded receptacle.

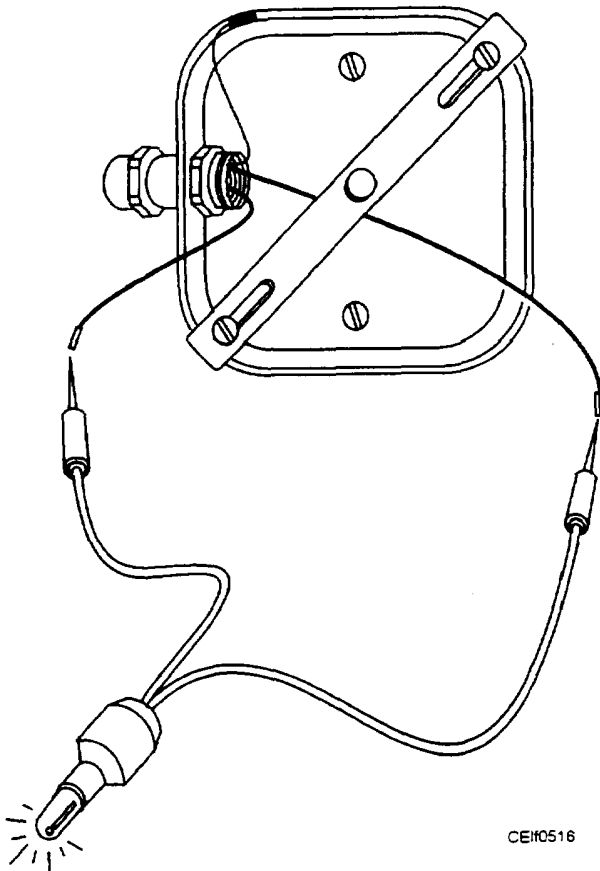

CEI#0516

Figure 5-16.—Technique for determining if voltage is reaching a light fixture.

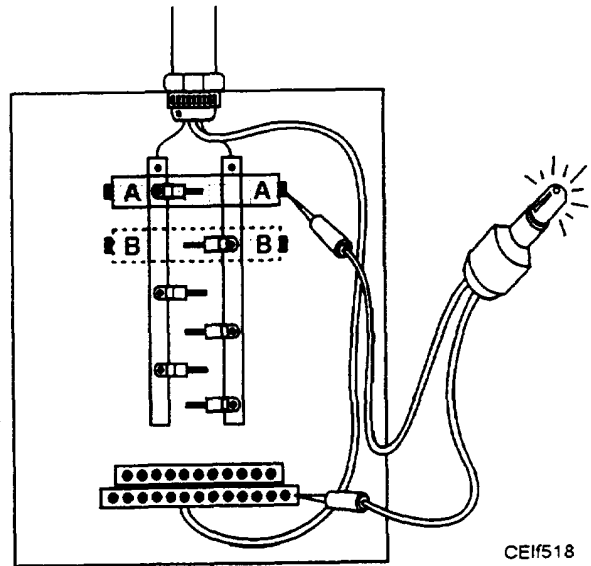

CEI#518

Figure 5-18.—Testing for proper operation of a circuit breaker.

Fuse

When a fuse is suspected of being defective, it may be checked with a neon tester using the four-part procedure shown in figure 5-19.

1. First determine if the voltage is present at the top of the fuses from the incoming lines. (Light should glow.)
2. Determine if the voltage is passing through the fuse. (If the neon tester fails to light, one or both fuses are defective.)
3. Check the left fuse to see if the voltage is present. If the light glows, the fuse is good; however, if it fails to light, the fuse is defective. Shut off the power and replace the fuse.
4. Check the right fuse to see if the voltage is present. If the light glows, the fuse is good; however, if it fails to light, the fuse is defective. Shut off the power and replace the fuse.

WARNING

To prevent electrical shock, do not replace the fuses unless the circuit is de-energized and then only with fuse pullers.

BENDING CONDUIT

Bending conduit is an art. Like all forms of art, the more often it is done correctly, the more proficient the artist becomes. It is recommended that you attend the SCBT 240.2 course that covers bending and installation of electrical conduits using mechanical benders. Keep in mind that practice will improve your skills and always read and follow the manufacturer's instruction guide. Following the guide will normally assure that you make top quality bends in a safe and efficient manner.

POWER BENDERS

Power benders are used for bending larger sizes of electrical metallic tubing (EMT), intermediate metallic tubing (IMC), and rigid conduit. Power benders come in many types and sizes. Some of the common ones are the hydraulic one-shot, sweep, and thin-wall benders. As for the mechanical benders, the thin-wall and sweep benders are common. The hydraulic benders use either a hand pump or an electric pump to move a shoe that does the actual bending. Figure 5-20 shows a hydraulic sweep bender that uses a

hand pump. By using different sizes of bending dies at different locations on the tie bar, you can use this bender to bend several types and sizes of conduit. The procedures for making the different types of bends with power benders are very similar to those used with manual benders. The main difference is that with the power benders, the take-up for 90-degree bends and the distance between bends for offsets will not be the same. This difference occurs because you are dealing with larger sizes of conduit or the shoes of the bender give a different radius of bend. Because there are so many different types and manufacturers of benders, remember to check the manufacturer's instruction guide before doing any bending.

BENDING FUNCTIONS AND SAFETY TIPS

In the following paragraphs, we will discuss some general information concerning power benders. This information does not replace the manufacturer's instruction guide, but only acquaints you with some basic functions and safety tips that you (as a crew leader) must be aware of.

When you are bending conduit, the bender must be in a horizontal position. When moving the bender any distance, place the pipe supports and pins in a 4-inch to 5-inch hole position. Then stand up the bender and roll it.

When connecting the high-pressure hose to the female quick-coupler on the end of the ram and the other end to the high-pressure pump female coupler, make sure that the quick-coupler is clean before making the connection. For the correct procedures for removing all the air from the pump and hoses, refer to the manufacturer's manual.

Some mechanical benders have an electrical power pump that is used to apply pressure on the ram. In this case, to operate the hydraulic pump, the motor must be running. Also, the quickest way to stop the advance of the ram is to stop the motor of the power pump.

WARNING

Read the pump operating instructions before operating the pump. Always place the control lever in the return position before starting the electric motor pump.

Regardless of what hydraulic bender you use, you must always check the manufacturer's charts and tables for the minimum stub length. When the

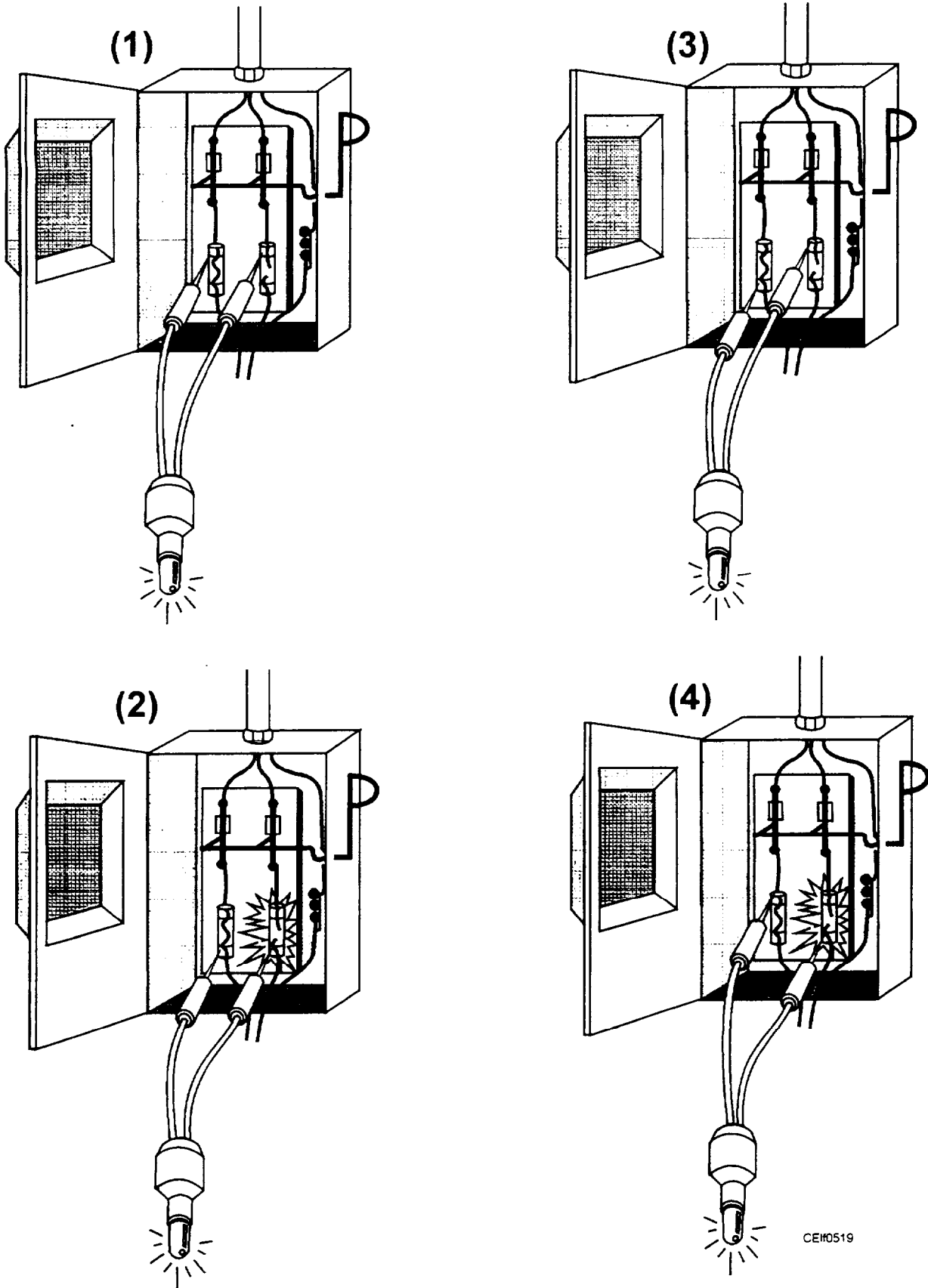

Figure 5-19.—Procedure used with a neon tester to isolate a defective fuse in a live circuit.

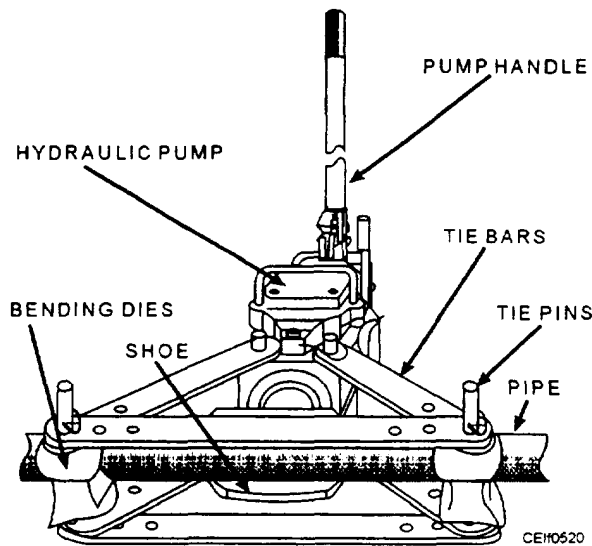

Figure 5-20.—Hydraulic sweep bender with hand pump.

manufacturer's tables and charts are not available, the conduit stub length must be equal to or greater than the minimum shown in table 5-3.

When bending conduit up to 90 degrees with a bender that has a ram travel scale, you should make your bend according to the ram travel scale reading.

An offset bend requires two bends of the same degree. To determine the distance between the two bends, you must first decide on the distance in inches of the offset and the degree of bend your conduit

Table 5-3.—Conduit Size/Deductions/Minimum Stub Lengths

CONDUIT SIZE	DEDUCT	MINIMUM STUB LENGTH
1/2	1 15/16	10
3/4	1 1/2	10
1	1 7/8	13
1 1/4	2 3/8	15 13/16
1 1/2	2 3/4	18 3/4
2	3 1/4	21 9/16
2 1/2	4 1/8	25
3	4 15/16	28 1/8
3 1/2	5 3/4	31
4	6 1/2	33 7/8

routing requires. Remember that the maximum conduit size and offset in inches may restrict your bend. Mark and bend your conduit according to the benders manufacturers' instructions, tables, and charts.

If you have access to a conduit pipe holder (normally for 1 1/4-inch to 4-inch conduit), it will simplify your work by keeping the pipe in perfect alignment at all times, achieving an outstanding bend. When offset bends are being made, the pipe holder permits making the first bend and then reversing the pipe end and making the second bend. The second bend will then be 180 degrees opposite the first bend.

CAUTION

Before using any pipe bender, make sure the quick-lock pins are through the holes in the bottom frame and the eccentric pin is turned clockwise past the ball lock. Also, make sure the correct sides of the pipe support pins are in the proper holes. Failure to ensure correct pin placement could result in damage to the conduit and/or the bender.

Occasionally conduit will require more bending. In this case, place the conduit in the bender and continue bending to the desired degree. This step is not necessary when using the Bending Degree Indicator (used for exact bends and reduces the necessity to correct bending caused by springback) or when using the Bending Degree Protractor because the bend will be accurate.

When you are bending long lengths of conduit, conduit pipe holders are very useful. Check the manufacturer's instruction guide for tables and charts that give vital information about conduit bending kit attachments.

When you have to make a large sweep 90-degree radius bend, you will need to get the operating manual of the bender you are using and follow the suggested procedures for marking the bend spacing and finding the necessary center location.

One of the benders that you may use in the field is the Greenlee™ 880 M2 Lightweight Hydraulic Bender. This bender is designed to make bends up to 90 degrees on rigid conduit from 1/2 inch to 2 inches inclusive. The 15-ton ram, the bending shoes, and the frame unit allow a complete 90-degree bend to be made with one piston stroke. The units of the bender can be rapidly and easily assembled for operation without any tools. By using the bending instructions and the piston

scale, you can make accurate bends. To assure easy portability, the manufacturer has designed the pipe supports for use as rollers; and parts are made of light-but-strong aluminum alloy whenever possible.

In the bending process, if the pipe is bent to the correct scale reading, overbends will not result. However: if you need to correct an overbend, you must follow the manufacturer's instructions that cover the bender that you are using.

As mentioned earlier, bending conduit is an art. The more you practice, the better you will be. Most bending charts show information on how to make bends to 15°, 30°, 45°, 60°, 90°, 180° and offset bends. When degrees of bend other than these are required and it is important that the bend be accurate, the Bending Degree Indicator should be used. The Bending Degree Indicator is extremely accurate and is very easy to use. The indicator also should be used when making segment bends to center radii greater than those of the bending shoe.

CONDUIT SUPPORTS AND INSTALLATION METHODS

To install conduit overhead and underground properly, you need to review the appropriate articles of the Code. Conduit should run as straight and direct as possible. There should never be more than the equivalent of four right-angle bends between outlets or fittings.

In installing exposed conduit runs where there are several conduits in the run, it is usually better to carry the erection of all of them together, rather than to complete one line before starting the others. If all are carried together, it is easier to keep all the raceways parallel, particularly at turns, and chances are that the job will look better.

Conduit can be supported on surfaces with pipe straps made in one-hole and two-hole types. On wooden surfaces, wood screws secure the straps in position. On masonry surfaces, machine screws that turn into lead expansion anchors can be used. Wooden plugs should never be used because no matter how well seasoned a plug appears to be, it usually will dry out to some extent and loosen in the hole. When laying out multiple-conduit runs, you must keep in mind the spacings between the conduits to permit proper placing of the straps. The screw-hole dimension (see table 5-4) enables you to order screws of the proper diameters to support the straps.

LOCATION OF CONDUIT SUPPORTS

The Code states that rigid-metal conduit will be firmly secured within 3 feet of each outlet box, junction box, cabinet, or fitting. The Code permits this distance to be increased to 5 feet where structural members do not readily permit fastening within 3 feet. Rigid-metal conduit will be supported at least every 10 feet; except that straight runs of conduit made up of

Table 5-4.—Spacings Requirements When Laying Out Multiple-Conduit Runs

Size of conduit (inches)	Conduit, width of opening (inches)	Conduit, height of opening (inches)	Width of conduit strap (inches)	Distance between centers of screw hole (inches)	Diameter of screw hole (inches)	Size of wood screw required
1/4	9/16	17/32	5/8	1-9/16	0.20	No. 8 × 5/8"
3/8	1 1/16	21/32	5/8	1-3/8	0.20	No. 8 × 3/4"
1/2	7/8	25/32	5/8	1-5/8	0.20	No. 8 × 3/4"
3/4	1/18	1	3/4	2-1/8	0.22	No. 10 × 3/4"
1	1-3/8	1-11/32	3/4	2-3/8	0.22	No. 10 × 7/8"
1-1/4	1-3/4	1-5/8	1-13/16	2-3/4	0.22	No. 10 × 1"
1-1/2	2	1-7/8	1-13/16	3	0.22	No. 10 × 1"
2	2-1/2	2-5/16	1	3-3/4	0.22	No. 10 × 1- 1/4"
2-1/2	2-3/4	2-15/16	7/8	4-3/3	0.25	No. 11 × 1- 1/4"

approved threaded couplings may be secured as shown in table 5-5, provided such fastening prevents transmission of stress to terminations when conduit is deflected between supports.

Table 5-5.—Spacing of Rigid-Metal Conduit Supports

CONDUIT SIZE (INCHES)	RIGID-METAL SUPPORT (FEET)
1/2 and 3/4	10
1	12
1-1/4 and 1-1/2	14
2 and 2-1/2	16
3 and larger	20

CONDUIT HANGERS AND SUPPORTS

A variety of conduit hangers and supports and several applications are shown in figure 5-21. U-channel supports are ideal for supporting several runs of conduits. In laying out these supports, consideration should be given to future conduit runs as well as those to be installed initially. It is a simple matter to provide U-channels or trapeze hangers with additional space for future conduits. This procedure greatly reduces the cost of installing new conduit at a later date. With the U-channel system, as shown in figure 5-21, special clamps are slipped into the channel slot, and the top bolt of the clamp securely fastens the conduit to the U-channel.

The U-channel can be directly fastened to a wall or ceiling, or it can be attached to bolted threaded rod

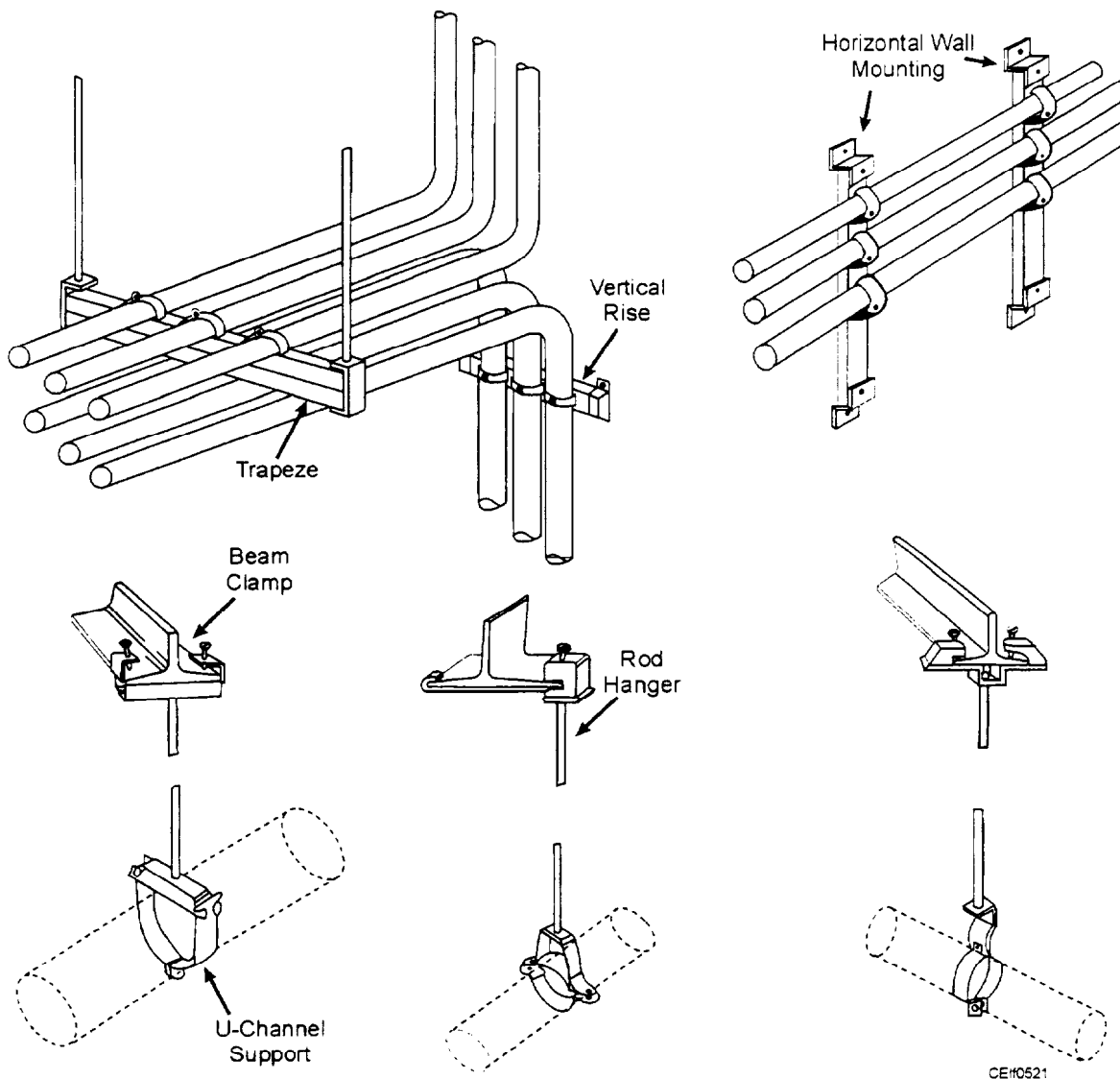

Figure 5-21.—Common conduit supports.

hangers suspended from ceilings, roof structures, or similar members.

Another excellent application for the U-channel is in suspended ceilings that contain lift-out ceiling panels. In modern construction, these lift-out panels provide ready access to mechanical and electrical equipment within the suspended-ceiling area. Accordingly, it is important that conduits installed in such an area do not prevent the removal of panels or access to the area. Rod-suspended U-channels provide the solution to conduit wiring in such areas.

Sections of the U-channel and associated fittings are available in aluminum or steel types. Another type of material that can be used for supports is slotted-angle-steel units. Numerous prepunched slots allow installers to bolt on rods, straps, and similar material without drilling holes. Slotted steel has unlimited applications in forming special structures, racks, braces, or similar items.

A cable-pulling kit (80149) has everything needed for any wire or cable-pulling job. Most large Public Works and all battalions have the wire installation kit. The heavy-duty power wire/cable puller plugs into any convenient 115-volt source. It pulls 15 feet of cable per minute and can be used with various attachments for almost any type of pulling job.

After a “fish” line has been blown or run through the conduit, a rope that is provided with the power cable puller can be pulled through the conduit. This rope, used with a cable grip, makes the actual pull. The power cable puller can be used in almost any configuration. Figures 5-22 through 5-27 are examples of the different setups.

SOLDERING AND SPLICING PROCEDURES

As a CE project supervisor or crew leader, you need to train your crew on the proper solderless connector splices, soldering splices, and taping splices. You will need to spot-check the connections to ensure proper installation.

SOLDERLESS CONNECTORS

Solderless connectors (wire nuts) have almost completely eliminated soldering and taping for certain types of splices. They are designated to hold several electrical wires firmly together and provide an

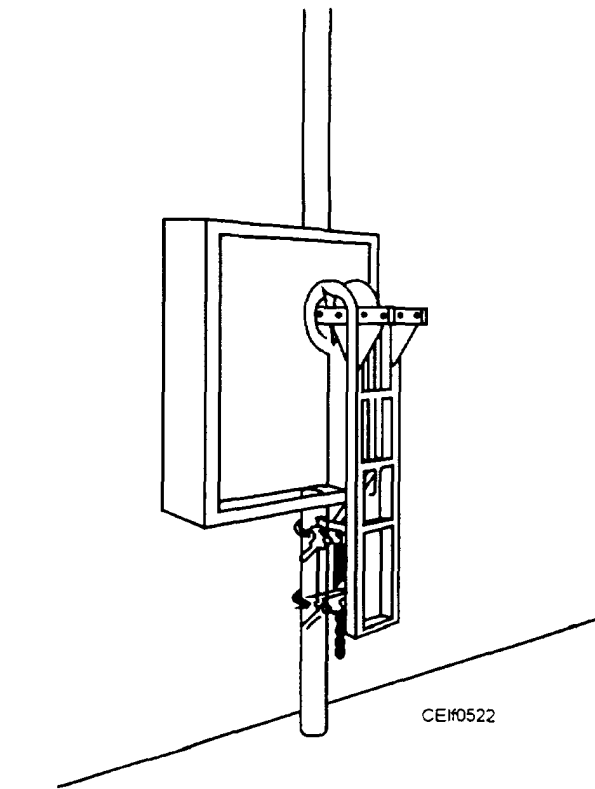

Figure 5-22.—Pipe adapter to exposed conduit.

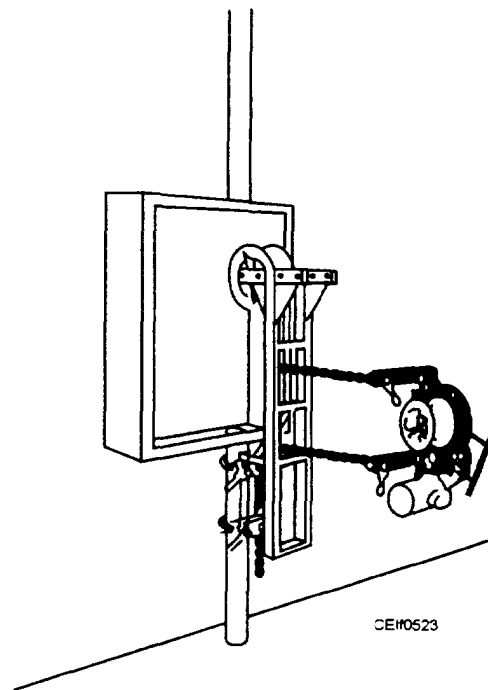

Figure 5-23.—Power unit to the power adapter.

insulating cover for the wires. They are available in several sizes. The size of the solderless connector is determined by the number and the size of the wires to be joined.

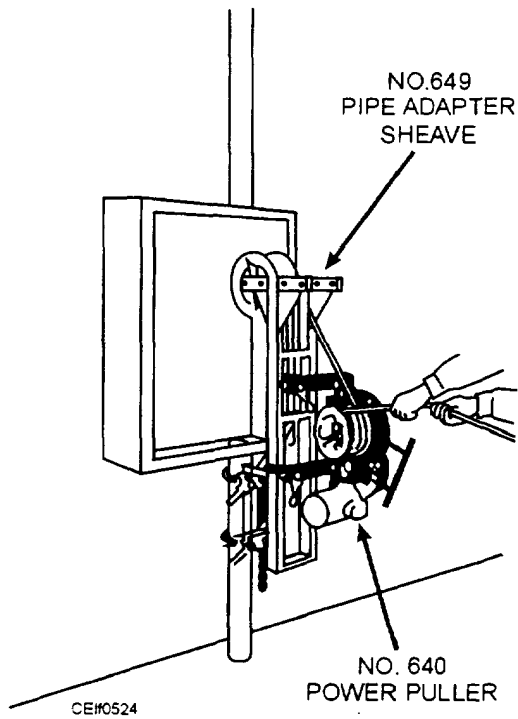

Figure 5-24.—“Up” pull, using exposed conduit.

SPLICES

An electrical splice is the joining of two or more electrical conductors by mechanically twisting them together or by using a special splicing device. Since splices can cause electrical problems, they must be made carefully. Splices must be able to withstand any reasonable mechanical strain that might be placed on the connection. They also must allow electricity to pass through as if the wire had never been broken. Some of the more common splices are explained below.

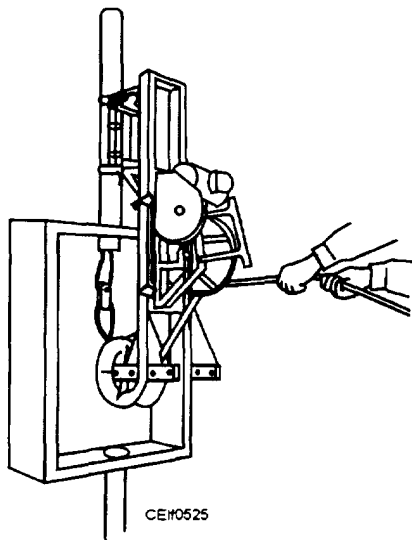

Figure 5-25.—“Down” pull, using exposed conduit.

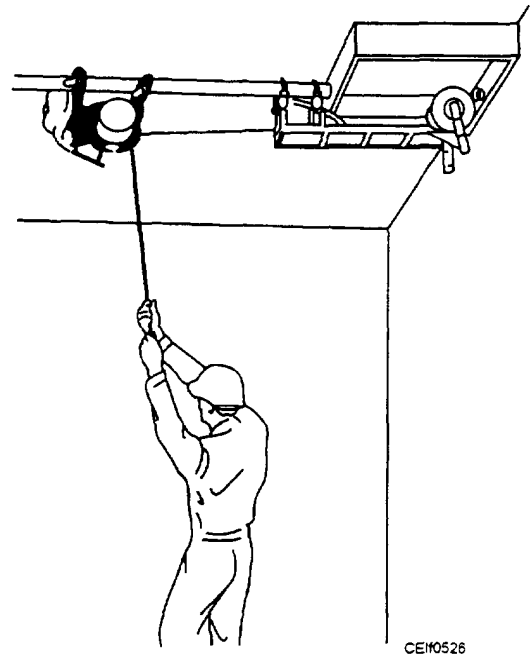

Figure 5-26.—Pulling in an overhead pull box with the puller mounted independently for extra cable.

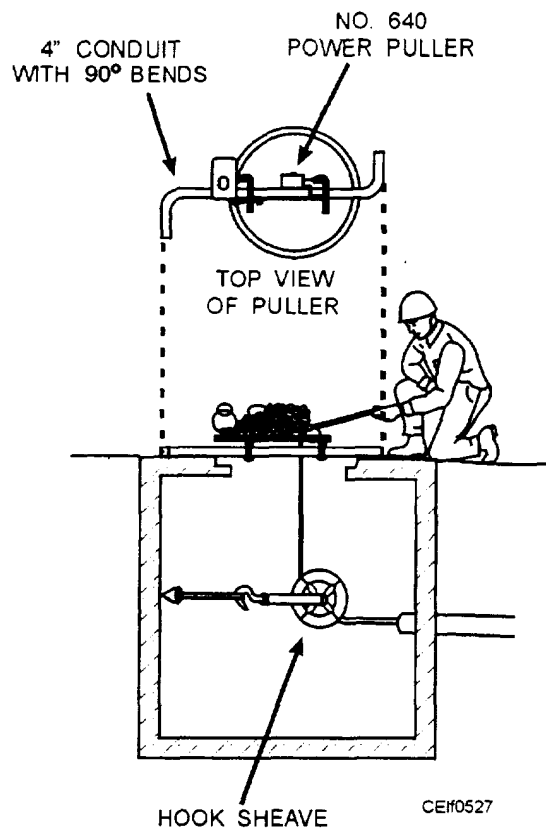

Figure 5-27.—Setup for ground pull.

Pigtail Splice

Because it is simple to make, the pigtail splice is probably the most commonly used electrical splice.

Figure 5-28 shows how to make a pigtail splice. Note the two ways to end the splice. When the splice is taped, the ends must be bent back so the sharp edges will not penetrate the tape (fig. 5-28). When a solderless connector is used instead of tape, the ends are cut off (fig. 5-28). When more than two wires are joined in a pigtail splice, as shown in figure 5-29, they should be twisted together securely before the solderless connector is put

on. Twisting the wires together first ensures that all the wires are fastened together properly.

Western Union Splice

The Western Union splice (fig. 5-30) is used when the connection must be strong enough to support long lengths of heavy, wire. In the past, this splice was used to repair telegraph wires. If the splice is to be taped, care should be taken to eliminate any sharp edges from the wire ends.

T-tap

The T-tap (fig. 5-31) is a type of splice that allows a connection to be made without cutting the main line. This connection is one of the most difficult to make. A certain amount of practice may be necessary to make this connection look neat. Study figure 5-3 1 to determine the proper technique in making this splice.

Portable Cord Splices

Cord splices are weak because there is no connector to hold them together; therefore, they should be used for emergency purposes only. If the cord must be saved, use twist lock plugs and receptacles to rejoin the cord. Figure 5-32 shows how solid wires are spliced. The individual splices are staggered to prevent a large bump when the cord is taped. Additional strength may be added to this splice by soldering each individual splice.

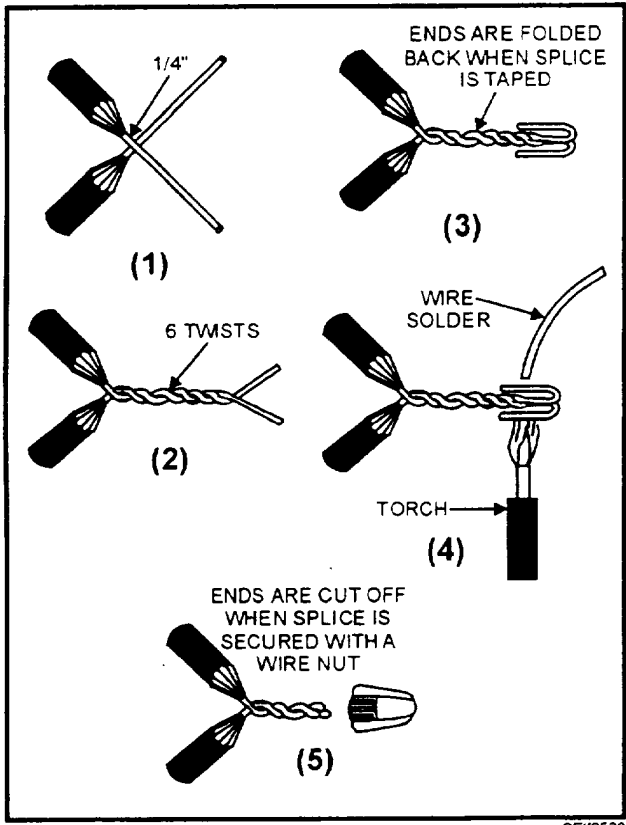

Figure 5-28.—Simple pigtail splice.

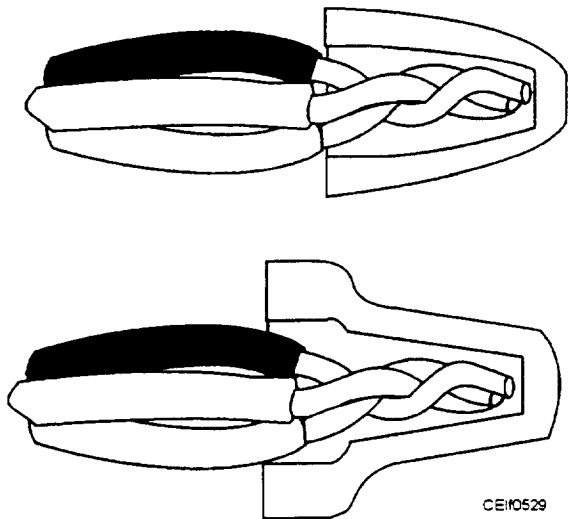

Figure 5-29.—Multiple-wire pigtail splice.

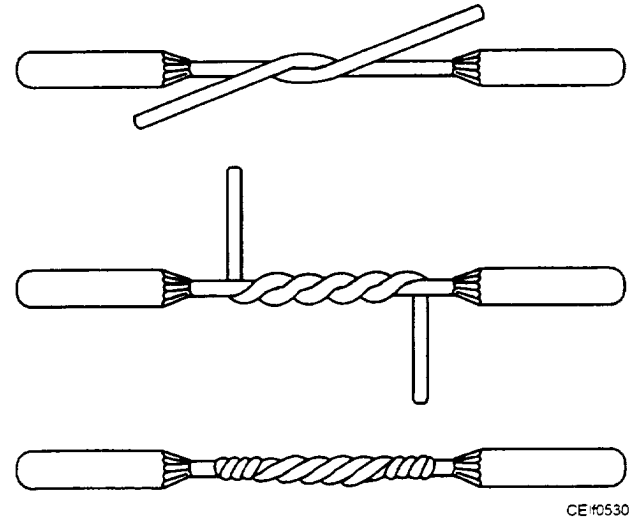

Figure 5-30.—Western Union splice used where substantial strain may be placed on the connection.

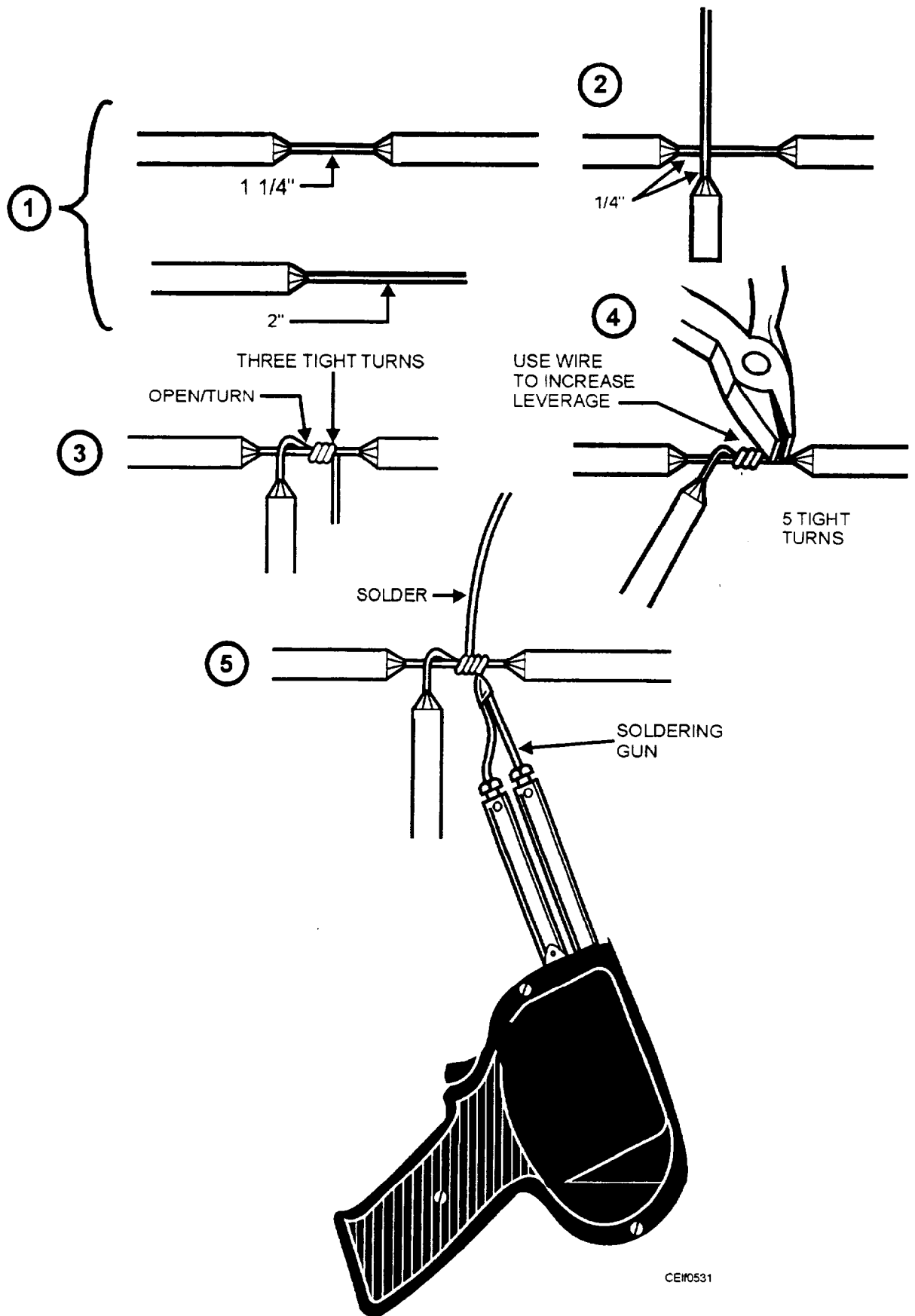

Figure 5-31.—T-tap used to connect into an ongoing line.

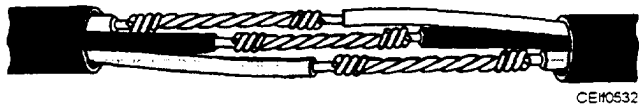

Figure 5-32.—Portable cord splices.

Cable Splices

Large stranded cables (fig. 5-33) are not often used in residential wiring; however, they are used in other situations, such as for battery jumper cables and welding cables. When jumper cables or welding cables are broken, they can be temporarily repaired, as shown in figure 5-33.

Soldering Splices

Because solderless connectors (such as plastic end caps) are time-saving and easy to use, the electrician no longer needs to solder each and every splice. It not only takes less time to make a solderless connection but also requires less skill. However, soldering is still the most reliable method of joining pieces of wire, and every electrician should learn how to solder.

Once the decision is made to solder an electrical splice and the insulation has been stripped off the wire, the splice should be soldered as soon as possible. The longer the splice is exposed to dirt and air, the more oxidation will occur thus lessening the chance of a good solder joint. Clean metal surfaces, free from oil, dirt, and rust (oxidation) are necessary to allow the melted solder to flow freely around the splice. The surfaces may be cleaned by using light sandpaper or an emery cloth or by applying flux to the joint as it is heated.

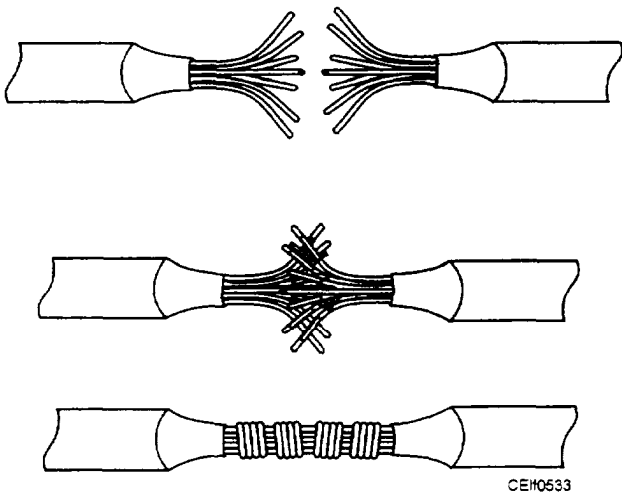

Figure 5-33.—Cable splices.

Solder usually comes in either bar or wire form and is melted with heat from soldering devices, such as a soldering iron, soldering gun, or propane torch (fig. 5-34).

The electric soldering iron and soldering gun are used when electrical service is available. The propane torch is used to solder large wires or when there is no electricity at the jobsite. Whatever method you use, be sure to apply solder on the side of the splice opposite the point where you apply the heat. Figure 5-35 shows the three methods of soldering. The melting solder will flow toward the source of heat. Thus, if the top of the wire is hot enough to melt the solder, the bottom of the wire closest to the heat source will draw the solder down through all the wires. Allow the splice to cool naturally without moving it. Do not blow on the joint or dip it in water to cool it. Rapid cooling will take all the strength out of a solder joint. Once it is cooled, clean off any excess flux with a damp rag, then dry and tape it.

WARNING

Avoid breathing the fumes and smoke from hot solder. Some solder contains lead which if inhaled or ingested can cause lead poisoning. Avoid prolonged skin contact with fluxes. Your supervisor will give you a Material Safety Data Sheet (MSDS) with the precautions for solder and flux.

Taping Splices

Taping is required to protect the splice from oxidation (formation of rust) and to insulate against electrical shock. Taping should provide at least as much insulation and mechanical protection for the splice as the original covering. Although one wrap of plastic (vinyl) tape will provide insulation protection up to 600 volts, several wraps may be necessary to provide good mechanical protection.

When plastic tape is used, it should be stretched as it is applied. Stretching will secure the tape more firmly. Figures 5-36 through 5-39 show the most commonly used methods of taping splices.

ELECTRICAL SAFETY

Safety for the electrician today is far more complicated than it was 20 years ago. But with proper use of today's safeguards and safety practices, working on electrical equipment can be safe. Electricity must be respected. With common sense and safe work practices, you can accomplish electrical work safely.

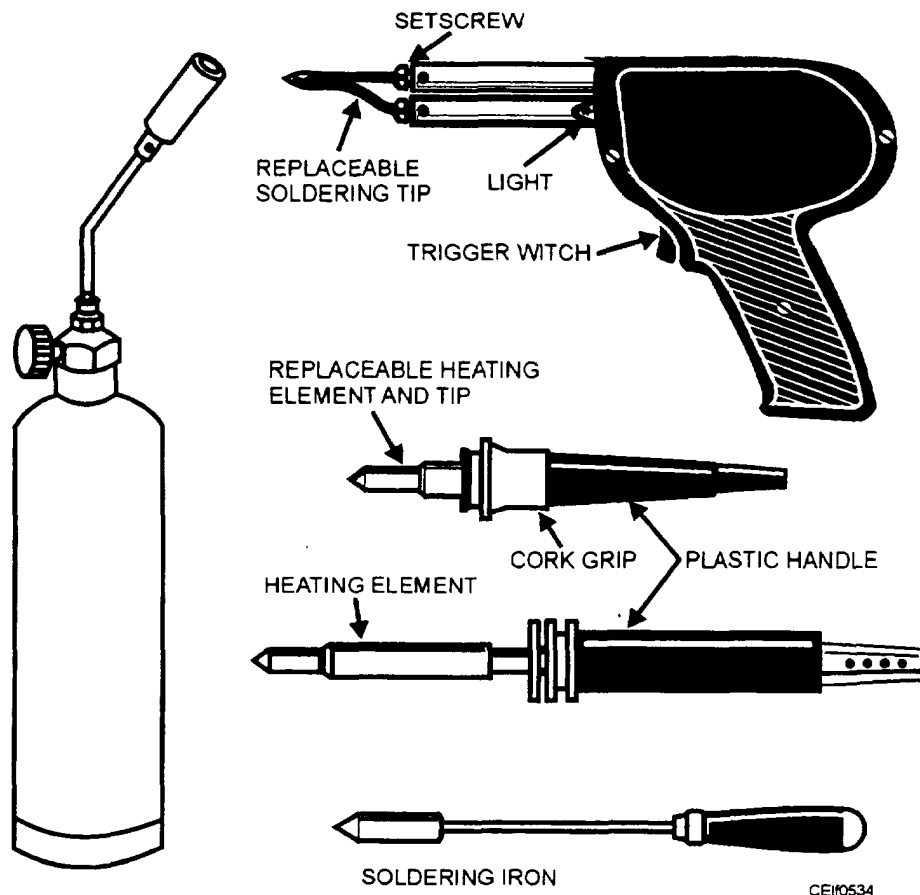

Figure 5-34.—Sources of heat for soldering splices.

An electrician must know and be able to apply the principles of electricity safety. If you disregard your own safety, you also disregard the safety of your fellow workers. Remember that the time to prevent an accident is before it happens. Respect for electricity comes from understanding electricity. Whenever in doubt, always ask your supervisor. Report any unsafe condition, unsafe equipment, or unsafe workpractices to your supervisor as soon as possible.

FUSES

Before removing any fuse from a circuit, be sure the switch for that circuit is open or disconnected. When removing fuses, use an approved type of fuse puller and break contact on the hot side of the circuit first. When replacing fuses, install the fuse first into the load side of the fuse clip, then into the line side.

ELECTRICAL SHOCK

Electrical shock occurs when a person comes in contact with two conductors of a circuit or when his or her body becomes part of the electrical circuit. In either case,

a severe shock can cause the heart and lungs to stop functioning. Also, because of the heat produced by current flow, severe burns may occur where the current enters and exits the body.

Prevention is the best medicine for electrical shock. Respect all voltages and follow safe work procedures. Do not take chances. CEs, with the exception of very few personnel with special training, are not qualified to work on live circuits.

PORTABLE ELECTRIC TOOLS

When using portable electric tools, always make sure they are in a safe operating condition. Make sure there is a third wire on the plug for grounding in case of shorts. Theoretically, if electric power tools are grounded and if an insulation breakdown occurs, the fault current should flow through the third wire to ground instead of through the operator's body to ground. Always use a ground-fault circuit-interrupter (GFCI) with portable electric tools. New power tools are double insulated eliminating the need for a ground prong; but for safety reasons, they still should be used with a GFCI.

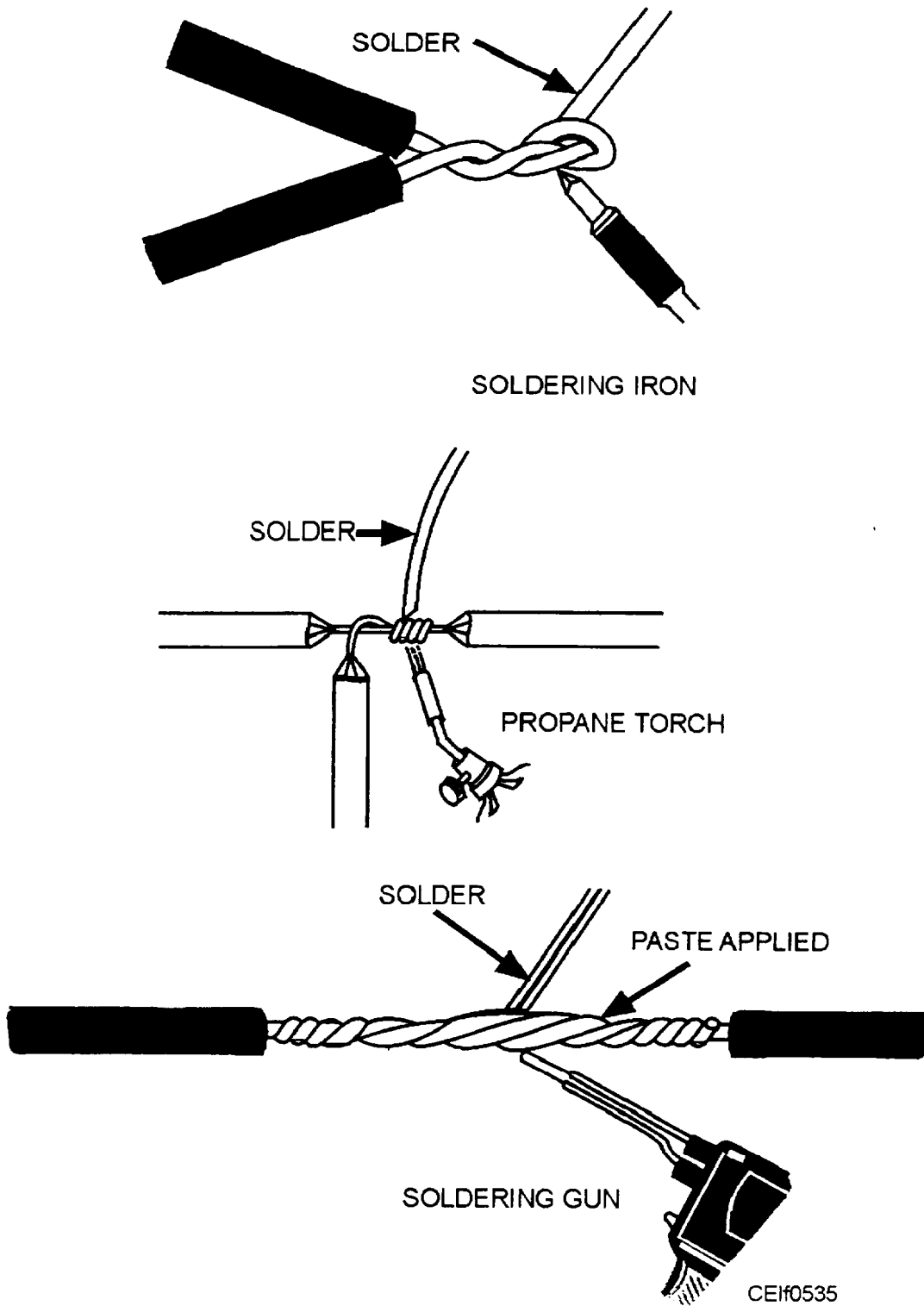

Figure 5-35.—Three methods of heating a solder joint.

OUT-OF-SERVICE PROTECTION

Before any repair is to be performed on a piece of electrical equipment, be absolutely certain the source of electricity is open and tagged or locked out of service. Whenever you leave your job for any reason or whenever

the job cannot be completed the same day, be sure the source of electricity is still open or disconnected when you return to continue the work. Seabees have died because they did not follow proper tag and lock-out procedures. These procedures are a must. It takes time to do it, but it is worth your life.

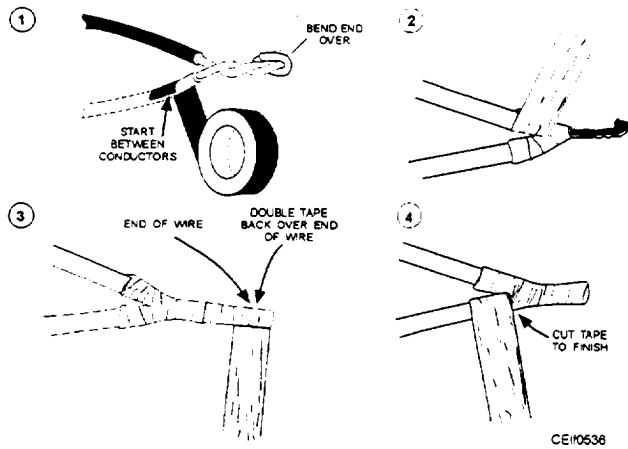

Figure 5-36.—Technique for taping a pigtail splice.

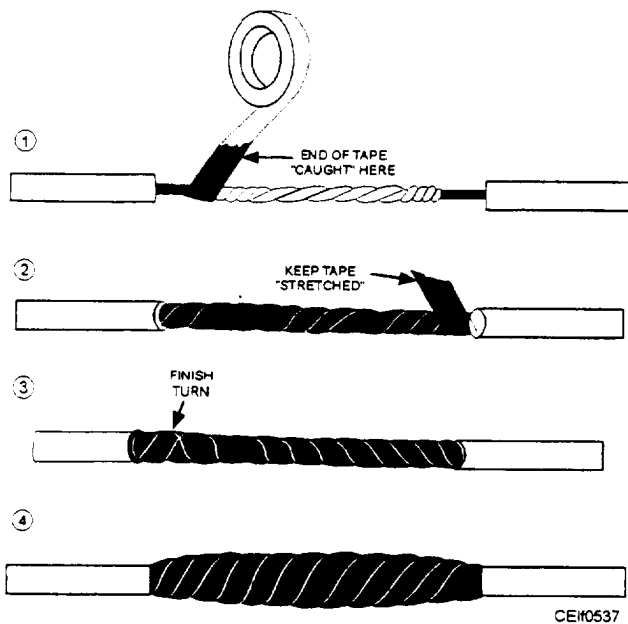

Figure 5-37.—Technique for taping a Western Union splice.

SAFETY COLOR CODES

Federal law (OSHA) has established specific colors to designate certain cautions and dangers. Table 5-6 shows the accepted usage. Study these colors and become familiar with all of them.

CLOTHING AND PERSONAL PROTECTIVE EQUIPMENT

As a crew leader, you must be familiar with required safety equipment and the conditions under which the equipment is to be used for your crew to perform an assigned task safely. The following is a list of common

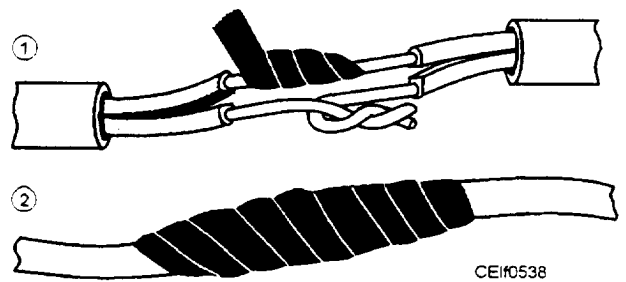

Figure 5-38.—Technique for taping a cord splice in an emergency only.

clothing and protective equipment requirements for working around electricity.

- Wear thick-soled work shoes for protection against sharp objects, such as nails. Wear work shoes with safety toes if the job requires.
- Wear electrically insulated gloves when there is the slightest chance that you might come in contact with energized parts.
- Wear rubber boots in damp locations.
- Wear safety goggles for protection against airborne particles, electrical sparks, and acid splashes.
- Wear a hard hat. Wear an approved safety helmet when on a project site. Be careful to avoid placing your head too near rotating machinery.
- Wear gloves when handling sharp objects.

FIRE SAFETY

Fire safety should always be of great concern to you as a shop supervisor or leader. Furthermore, every member of your crew should be concerned with fire safety. The following fire safety information will help you prevent or combat fires.

The chances of fire may be greatly decreased by following rules of good housekeeping. Keep debris in a designated area away from the building. Report to your supervisor any accumulations of rubbish or unsafe conditions that are a fire hazard.

If a fire should occur, however, the first thing to do is give an alarm. All workers on the job should be alerted; the fire department should be called. In the time before the fire department arrives, a reasonable effort can be made to contain the fire. In the case of some smaller fires, portable fire extinguishers that should be available at the site can be used.

Table 5-6.—OSHA Safety Color Codes

OSHA SAFETY COLOR CODES	
Red	Fire protection equipment and apparatus: portable containers of flammable liquids: emergency stop buttons; switches
Yellow	Caution and for marking physical hazards. waste containers for explosive or combustible materials; caution against starting. using. or moving equipment under repair: identification of the starting point or power source of machinery
Orange	Dangerous parts of machines; safety start buttons; the exposed parts (edges) of pulleys, gears, rollers. cutting devices. and power jaws
Purple	Radiation hazards
Green	Safety; location of first aid equipment (other than fire fighting equipment)

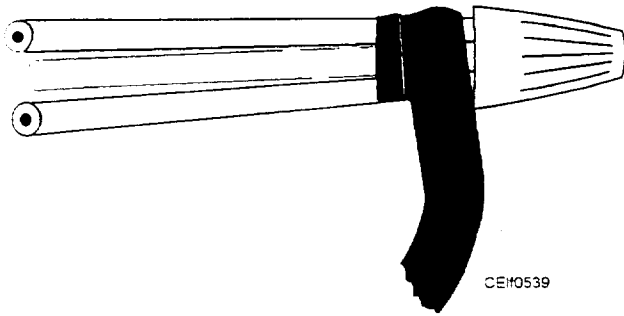

Figure 5-39.—Technique for taping a solderless connector.

The following list gives the four common types of fire. Each type of fire is designated by a class.

- Class A fires occur in wood, clothing, paper, rubbish, and other such items. This type of fire usually can be handled effectively with water. (Symbol: green triangle.)

- Class B fires occur with flammable liquids, such as gasoline, fuel oil, lube oil, grease, thinners, paints, and so forth. The agents required for extinguishing this type of fire are those that will dilute or eliminate the air by blanketing the surface of the fire. Foam, CO₂, and dry chemicals are used, but not water. (Symbol: red square.)

- Class C fires occur in electrical equipment and facilities. The extinguishing agent for this type of fire must be a nonconductor of electricity and provide a smothering effect. CO₂ and dry chemical extinguishers may be used, but not water. (Symbol: blue circle.)

- Class D fires occur in combustible metals, such as magnesium, potassium, powdered aluminum, zinc,

sodium, titanium, zirconium, and lithium. The extinguishing agent for this type of fire must be a dry-powdered compound. The dry-powdered compound must create a smothering effect. (Symbol: yellow star.)

Figure 5-40 shows the symbols that are associated with the four classes. One or more of these symbols should appear on each extinguisher. Because all fire extinguishers cannot be used on all types of fires, the electrician should be aware of how to identify which fire extinguisher should be used.

Always read the operator's instructions before using an extinguisher. Also, never use water against electrical or chemical fires. Water also should not be used against gasoline, fuel, or paint fires, as it may have little effect and only spread the fire. Figure 5-41 shows some common fire extinguishers and their uses.

Fire extinguishers are normally red. If they are not red, they should have a red background so they can be easily located.

If the fire department is called, be ready to direct them to the fire. Also, inform them of any special problems or conditions that exist, such as downed electrical wires or leaks in gas lines.

In this chapter we have discussed various aspects of interior wiring (above and below grade), bending conduit, conduit support and installation, soldering and splicing, and electrical and fire safety. Each of these areas was briefly discussed and reference given to where you could find additional specific information. To understand the material discussed, you must study these references.

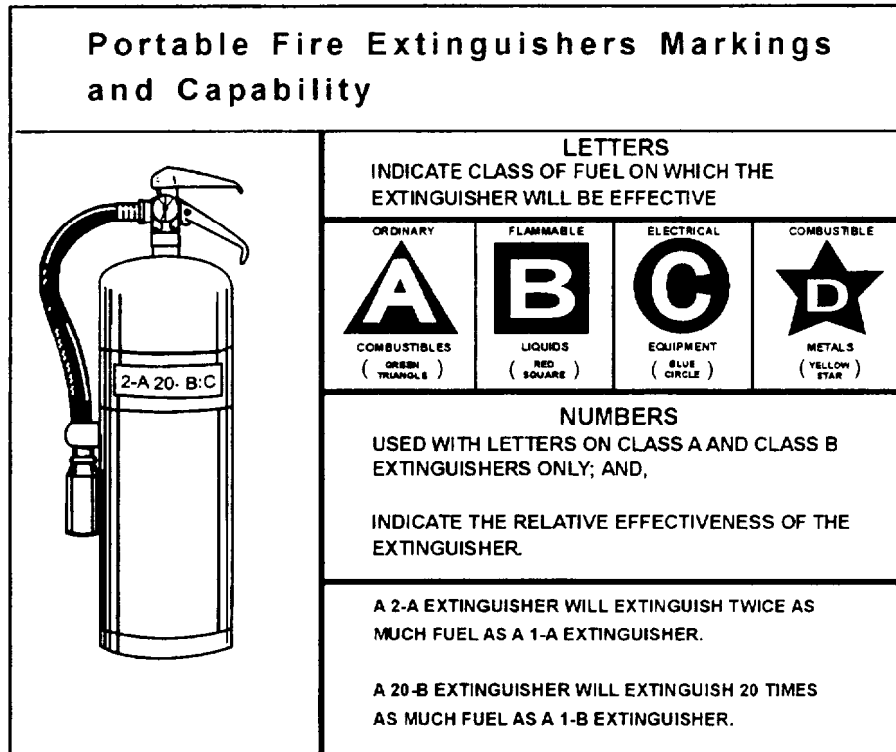

CE10540

Figure 5-40.—Fire extinguisher markings and capabilities.

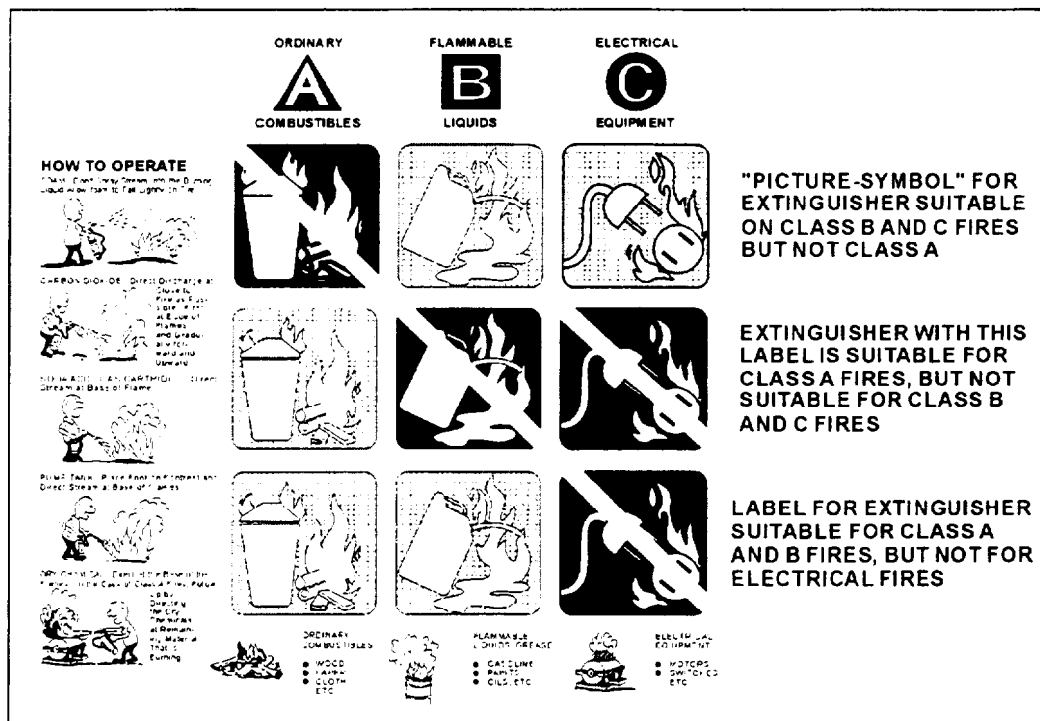

CE10541

Figure 5-41.—Selection of an effective and safe fire extinguisher.

The following listed handbooks are excellent examples of references for further study.

- *Standard Handbook for Electrical Engineers* by Donald G. Fink and H. Wayne Beaty.

- *American Electrician's Handbook* by Terrell Croft and Wilford I. Summers.
- *National Electrical Code*® by the National Fire Protection Agency.

CHAPTER 6

FIBER OPTICS AND LIGHTING SYSTEMS

INTRODUCTION

This chapter will expand on the information you learned in the CE Basic TRAMAN on fiber optics and area lighting and also introduce you to airfield lighting systems.

FIBER OPTICS

The CE Basic TRAMAN taught you that a fiber-optic data link had three basic functions:

- To convert an electrical input signal to an optical signal
- To send the optical signal over an optical fiber
- To convert the optical signal back to an electrical signal

The fiber-optic data link converts an **electrical signal** into an **optical signal**, permitting the transfer of data along an optical fiber. The fiber-optic device responsible for that signal conversion is a fiber-optic transmitter. A **fiber-optic transmitter** is a hybrid device. The transmitter converts electrical signals into optical signals and launches the optical signals into an optical fiber. A fiber-optic transmitter consists of an **interface circuit**, a **source drive circuit**, and an **optical source**.

The **interface circuit** accepts the incoming electrical signal and processes it to make it compatible with the source drive circuit. The **source drive circuit** intensity modulates the optical source by varying the current through the source. An optical source converts electrical energy (current) into optical energy (light). Light emitted by an **optical source** is launched, or coupled, into an optical fiber for transmission.

Fiber-optic data link performance depends on the amount of optical power (light) launched into the optical fiber. This chapter provides an overview of optical sources and fiber optic transmitters.

OPTICAL SOURCE PROPERTIES

The development of efficient semiconductor optical sources, along with low-loss optical fibers, has led to substantial improvements in fiber-optic

communications. Semiconductor optical sources have the physical characteristics and performance properties necessary for successful implementations of fiber-optic systems. Optical sources should do the following:

- Be compatible in size to low-loss optical fibers by having a small light-emitting area capable of launching light into fiber.
- Launch sufficient optical power into the optical fiber to overcome fiber attenuation and connection losses, allowing for signal detection at the receiver.
- Emit light at wavelengths that minimize optical fiber loss and dispersion. Optical sources should have a narrow spectral width to minimize dispersion.
- Allow for direct modulation of optical output power.
- Maintain stable operation in changing environmental conditions (such as temperature).
- Cost less and be more reliable than electrical devices, thereby permitting fiber-optic communication systems to compete with conventional systems.

Semiconductor optical sources suitable for fiber-optic systems range from inexpensive light-emitting diodes (LEDs) to more expensive semiconductor lasers. Semiconductor LEDs and laser diodes (LDs) are the principal light sources used in fiber optics.

SEMICONDUCTOR LIGHT-EMITTING DIODES AND LASER DIODES

Semiconductor LEDs emit **incoherent light**. Spontaneous emission of light in semiconductor LEDs produces light waves that lack a fixed-phase relationship. Light waves that lack a fixed-phase relationship are referred to as **incoherent light**. LEDs are the preferred optical source for multimode systems because they can launch sufficient power at a lower cost than semiconductor laser diodes (LDs).

Semiconductor LDs emit **coherent light**. Light waves having a fixed-phase relationship are referred to as coherent light. Since semiconductor LDs emit more focused light than LEDs, they are able to launch optical

power into both single mode and multimode optical fibers; however, LDs usually are used only in single mode fiber systems because they require more complex driver circuitry and cost more than LEDs.

Optical power produced by optical sources can range from microwatts (μW) for LEDs to tens of milliwatts (μW) for semiconductor LDs; however, it is not possible to couple all the available optical power effectively into the optical fiber for transmission.

The amount of optical power coupled into the fiber is the relevant optical power. It depends on the following factors:

- The angles over which the light is emitted
- The size of the light-emitting area of the source relative to the fiber core size
- The alignment of the source and fiber
- The coupling characteristics of the fiber

Typically, semiconductor lasers emit light spread out over an angle of 10 to 15 degrees. Semiconductor LEDs emit light spread out at even larger angles. Coupling losses of several decibels (dB) can easily occur when coupling light from an optical source to a fiber, especially with LEDs.

SEMICONDUCTOR MATERIAL

Understanding optical emission in semiconductor lasers and LEDs requires knowledge of semiconductor material and device properties. Providing a complete description of semiconductor properties is beyond the scope of this text. In this chapter we will only discuss the general properties of semiconductor LEDs and LDs.

Semiconductor sources are diodes, with all of the characteristics typical of diodes; however, their construction includes a special layer, called the active layer, that emits photons (light particles) when a current passes through the layer. The particular properties of the semiconductor are determined by the materials used and the layering of the materials within the semiconductor. **Silicon (Si)** and **gallium arsenide (GaAs)** are the two most common semiconductor materials used in electronic and electro-optic devices. In some cases, other elements, such as aluminum (Al), indium (In), and phosphorus (P), are added to the base semiconductor material to modify the semiconductor properties. These elements are called dopants. Current flowing through a semiconductor optical source causes it to produce light.

LEDs generally produce light through **spontaneous emission** when a current is passed through them. Spontaneous emission is the random generation of photons within the active layer of the LED. The emitted photons move in random directions. Only a certain percentage of the photons exit the semiconductor and are coupled into the fiber. Many of the photons are absorbed by the LED materials and the energy is dissipated as heat. This process causes the light output from a LED to be incoherent, have a broad spectral width, and have a wide output pattern.

Laser diodes are much more complex than LEDs. **Laser** is an acronym for **Light Amplification by the Stimulated Emission of Radiation**. Laser diodes produce light through stimulated emission when a current is passed through them. **Stimulated emission** describes how light is produced in any type of laser. In the laser diode, photons, initially produced by, spontaneous emission, interact with the laser material to produce additional photons. This process occurs within the active area of the diode called the laser cavity.

As with the LED, not all of the photons produced are emitted from the laser diode. Some of the photons are absorbed and the energy dissipated as heat. The emission process and the physical characteristics of the diode cause the light output to be coherent, have a narrow spectral width, and have a narrow output pattern.

It is important to note that in both LED and laser diodes all of the electrical energy is not converted into optical energy. A substantial portion is converted to heat. Different LED and laser diode structures convert different amounts of electrical energy into optical energy.

FIBER-OPTIC TRANSMITTERS

As stated previously, a fiber-optic transmitter is a hybrid electro-optic device. It converts electrical signals into optical signals and launches the optical signals into an optical fiber. A fiber-optic transmitter consists of an interface circuit, a source drive circuit, and an optical source. The interface circuit accepts the incoming electrical signal and processes it to make it compatible with the source drive circuit. The source drive circuit intensity modulates the optical source by varying the current through it. The optical signal is coupled into an optical fiber through the transmitter output interface.

Although semiconductor LEDs and LDs have many similarities, unique transmitter designs result

from differences between LED and LD sources. Transmitter designs compensate for differences in optical output power, response time, linearity, and thermal behavior between LEDs and LDs to ensure proper system operation. Fiber-optic transmitters using LDs require more complex circuitry than transmitters using LEDs.

Transmitter output interfaces generally fall into two categories: optical connectors and optical fiber pigtails (fig. 6-1). **Optical pigtails** are attached to the transmitter optical source. This pigtail is generally routed out of the transmitter package as a coated fiber in a loose buffer tube or a single fiber cable. The pigtail is either soldered or epoxied to the transmitter package to provide fiber strain relief. The buffer tube or single fiber cable also is attached to the transmitter package to provide additional strain relief.

The transmitter output interface may consist of a **fiber-optical connector**. The optical source may couple to the output optical connector through an intermediate optical fiber. One end of the optical fiber is attached to the source. The other end terminates in

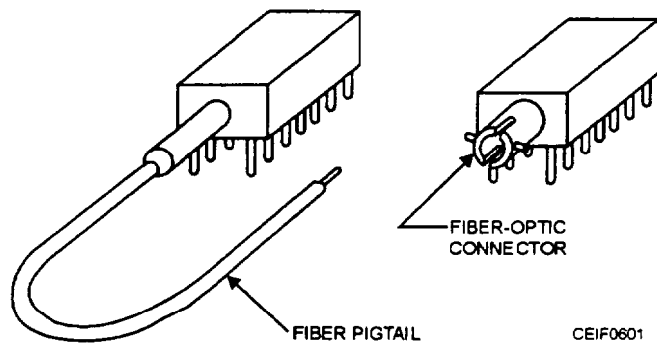

Figure 6-1.—Pigtailed and connectorized fiber-optic devices.

the transmitter optical output connector. The optical source also may couple to the output optical connector without an intermediate optical fiber. The optical source is placed within the transmitter package to launch power directly into the fiber of the mating optical connector. In some cases, **lenses** are used to more efficiently couple light from the source into the mating optical connector.

OPTICAL DETECTORS AND FIBER-OPTIC RECEIVERS

A fiber-optic transmitter is an electro-optic device capable of accepting electrical signals, converting them into optical signals, and launching the optical signals into an optical fiber. The optical signals propagating in the fiber become weakened and distorted because of scattering, absorption, and dispersion. The fiber-optic device responsible for converting the weakened and distorted optical signal back to an electrical signal is a fiber-optic receiver.

A **fiber-optic receiver** is an electro-optic device that accepts optical signals from an optical fiber and converts them into electrical signals. A typical fiber-optic receiver consists of an optical detector, a low-noise amplifier, and other circuitry used to produce the output electrical signal (fig. 6-2). The optical detector converts the incoming optical signal into an electrical signal. The amplifier then amplifies the electrical signal to a level suitable for further signal processing. The type of other circuitry contained within the receiver depends on what type of modulation is used and the receiver's electrical output requirements.

A **transducer** is a device that converts input energy of one form into output energy of another. An **optical detector** is a transducer that converts an optical signal into an electrical signal. It does this by generating an electrical current proportional to the

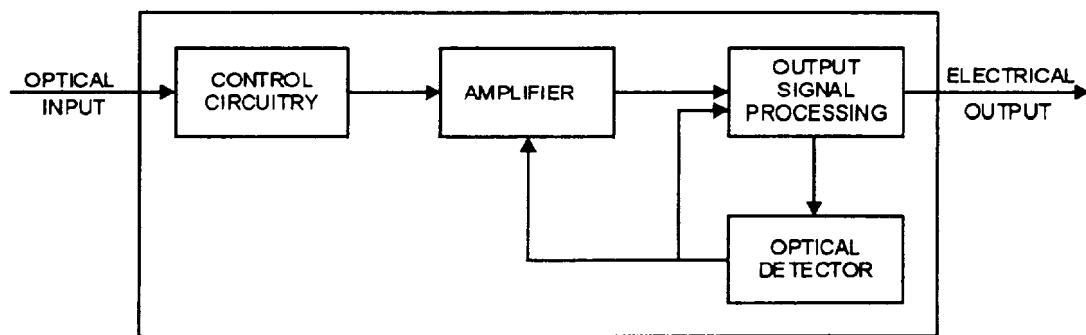

Figure 6-2.—Block diagram of a typical fiber-optic receiver.

intensity of incident optical radiation. The relationship between the input optical radiation and the output electrical current is given by the detector responsivity.

FIBER-OPTIC SYSTEM TOPOLOGY

Most of the discussion on fiber-optic data links provided earlier in this chapter and in the CE Basic TRAMAN refers to simple point-to-point links. A **point-to-point** fiber-optic data link consists of an optical transmitter, an optical fiber, and an optical receiver. In addition, any splices or connectors used to join individual optical fiber sections to each other and to the transmitter and the receiver are included. Figure 6-3 provides a schematic diagram of a point-to-point fiber-optic data link.

A common fiber-optic application is the full duplex link. This link consists of two simple point-to-point links. The links transmit in opposite directions between the equipment. This application may be configured using only one fiber. If configured with one fiber, fiber-optic splitters are used at each end to couple the transmit signal onto the fiber and receive signals to the detector.

All fiber-optic systems are simply sets of point-to-point fiber-optic links. Different system topologies arise from the different ways that point-to-point fiber-optic links can be connected between equipment. The term **topology**, as used here, refers to the configuration of various types of equipment and the fiber-optic components interconnecting them. This equipment may be computers, workstations, consoles, or other equipment. Point-to-point links are connected to produce systems with linear bus, ring, star, or tree topologies. Point-to-point fiber-optic links are the basic building block of all fiber-optic systems.

SYSTEM INSTALLATION

The Navy has a standard to provide detailed information and guidance to personnel concerned with the installation of fiber-optic cables and cable plants. The **fiber-optic cable plant** consists of all the fiber-

optic cables and the fiber-optic interconnection equipment, including connectors, splices, and interconnection boxes. The fiber-optic cable and cable plant installation standard consists of the following:

- Detailed methods for cable storage and handling, end sealing, repair, and splicing
- Detailed methods for fiber-optic equipment installation and cable entrance to equipment
- Detailed methods to install fiber-optic cables in cableways
- Detailed methods for installing fiber-optic connectors and other interconnections, such as splices
- Detailed methods for testing fiber-optic cable plants before, during, and after installation and repair

There are other standards that discuss fiber-optic system installation. Many of these standards incorporate procedures for repair, maintenance, and testing. The techniques developed for installing fiber-optic hardware are not much different than for installing hardware for copper-based systems: however, the primary precautions that need to be emphasized when installing fiber-optic systems are as follows:

- Optical fibers or cables should never be bent at a radius of curvature less than a certain value, called the **minimum bend radius**. Bending an optical fiber or cable at a radius smaller than the minimum bend radius causes signal loss.
- Fiber-optic cables should never be pulled tight or fastened over or through sharp corners or cutting edges. Extremely sharp bends increase the fiber loss and may lead to fiber breakage.
- Fiber-optic connectors should always be cleaned before mating. Dirt in a fiber-optic connection will significantly increase the connection loss and may damage the connector.
- Precautions must be taken so the cable does not become kinked or crushed during installation of the

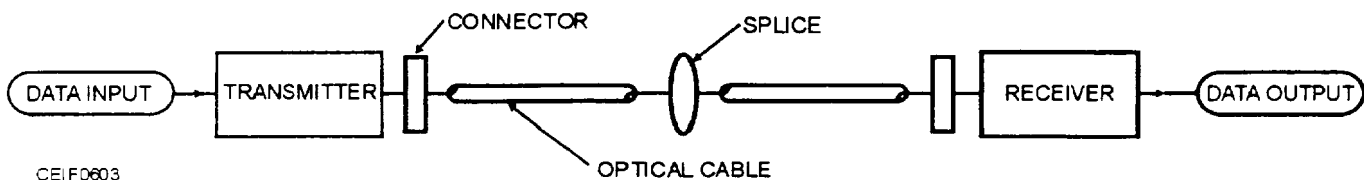

Figure 6-3.—A schematic diagram of a point-to-point fiber-optic data link.

hardware. Extremely sharp kinks or bends increase the fiber loss and may lead to fiber breakage.

FIBER-OPTIC MEASUREMENTS

Fiber-optic data links operate reliably if fiber-optic component manufacturers and you perform the necessary laboratory and field measurements. Manufacturers must test how component designs, material properties, and fabrication techniques affect the performance of fiber-optic components. These tests can be categorized as design tests or quality control tests. Design tests are conducted during the development of a component. Design tests characterize the performance of the component (optical, mechanical, and environmental) in the intended application. Once the performance of the component is characterized, the manufacturer generally only conducts quality control tests. Quality control tests verify that the parts produced are the same as the parts the design tests were conducted on. When manufacturers ship fiber-optic components, they provide quality control data detailing the results of measurements performed during or after fabrication of the component.

You, as the installer, should measure some of these parameters upon receipt before installing the component into the fiber-optic data link. These tests determine if the component has been damaged in the shipping process. In addition, you should measure some component parameters after installing or repairing fiber-optic components in the field. The values obtained can be compared to the system installation specifications. These measurements determine if the installation or repair process has degraded performance of the component and will affect data link operation.

FIELD MEASUREMENTS

Field measurements measure the transmission properties of installed fiber-optic components. You must perform field measurements to evaluate those properties most likely affected by the installation or repair of fiber-optic components or systems.

The discussion on field measurements is limited to optical fiber and optical connection properties. Optical fiber and optical connection field measurements evaluate only the transmission properties affected by component or system installation or repair. Because optical fiber geometrical properties, such as core and cladding diameter and numerical aperture, are not expected to change, there is no need to remeasure these

properties. The optical connection properties that are likely to change are connection insertion loss and reflectance and return loss.

Field measurements require rugged, portable test equipment, unlike the sophisticated test equipment used in the laboratory. Field test equipment must provide accurate measurements in extreme environmental conditions. Since electrical power sources may not always be available in the field, test equipment should allow battery operation. In addition, while both fiber ends are available for conducting laboratory measurements, only one fiber end may be readily available for field measurements. Even if both fiber ends are available for field measurements, the fiber ends are normally located some distance apart, thereby requiring two people to perform the measurements.

The main field measurement technique involves optical time domain reflectometry. An **optical time domain reflectometer (OTDR)** is recommended for conducting field measurements on installed optical fibers or links of 50 meters or more in length. An OTDR requires access to only one fiber end. An OTDR measures the attenuation of installed optical fibers as a function of length. It also identifies and evaluates optical connection losses along a cable link and locates any fiber breaks or faults.

Users also can measure fiber attenuation and cable plant transmission loss, using an optical power meter and a stabilized light source. Use this measurement technique when optical time domain reflectometry is not recommended. Measurements obtained with a stabilized light source and power meter are more accurate than those obtained with an OTDR. Measuring fiber attenuation and transmission loss using a power meter and light source requires access to both ends of the fiber or link. An **optical loss test set (OLTS)** combines the power meter and source functions into one physical unit.

OPTICAL TIME DOMAIN REFLECTOMETRY

You use optical time domain reflectometry to characterize optical fiber and optical connection properties in the field. In optical time domain reflectometry, an OTDR transmits an optical pulse through an installed optical fiber. The OTDR measures the fraction of light that is reflected back. When you compare the amount of light scattered back at different times, the OTDR can determine fiber and connection losses. When several fibers are connected to form an

installed cable plant, the OTDR can characterize optical fiber and optical connection properties along the entire length of the cable plant. A **fiber-optic cable plant** consists of optical fiber cables, connectors, splices, mounting panels, jumper cables, and other passive components. A cable plant does not include active components, such as optical transmitters or receivers.

The OTDR displays the backscattered and reflected optical signal as a function of length. The OTDR plots half the power in decibels (dB) versus half the distance. Plotting half the power in dB and half the distance corrects for round-trip effects. By analyzing the OTDR plot, or trace, you can measure fiber attenuation and transmission loss between any two points along the cable plant. You also can measure insertion loss and reflectance of any optical connection. In addition, you use the OTDR trace to locate fiber breaks or faults. Figure 6-4 shows an example OTDR trace of an installed cable plant.

MECHANICAL AND FUSION SPLICES

Mechanical splicing involves using mechanical fixtures to align and connect optical fibers. Mechanical splicing methods may involve either passive or active core alignment. Active core alignment produces a lower loss splice than passive alignment; however, passive core alignment methods

can produce mechanical splices with acceptable loss measurements even with single mode fibers.

In the strictest sense, a mechanical splice is a permanent connection made between two optical fibers. Mechanical splices hold the two optical fibers in alignment for an indefinite period of time without movement. The amount of splice loss is stable over time and unaffected by changes in environmental or mechanical conditions.

The types of mechanical splices that exist for mechanical splicing include glass, plastic, metal, and ceramic tubes; also included are V-groove, and rotary devices: Materials that assist mechanical splices in splicing fibers include transparent adhesives and index matching gels. **Transparent adhesives** are epoxy resins that seal mechanical splices and provide index matching between the connected fibers.

GLASS OR CERAMIC ALIGNMENT TUBE SPLICES

Mechanical splicing may involve the use of a glass or ceramic alignment tube or capillary. The inner diameter of this glass or ceramic tube is only slightly larger than the outer diameter of the fiber. A transparent adhesive, injected into the tube, bonds the two fibers together. The adhesive also provides index matching between the optical fibers. Figure 6-5 illustrates fiber alignment using a glass or ceramic tube. This splicing technique relies on the inner

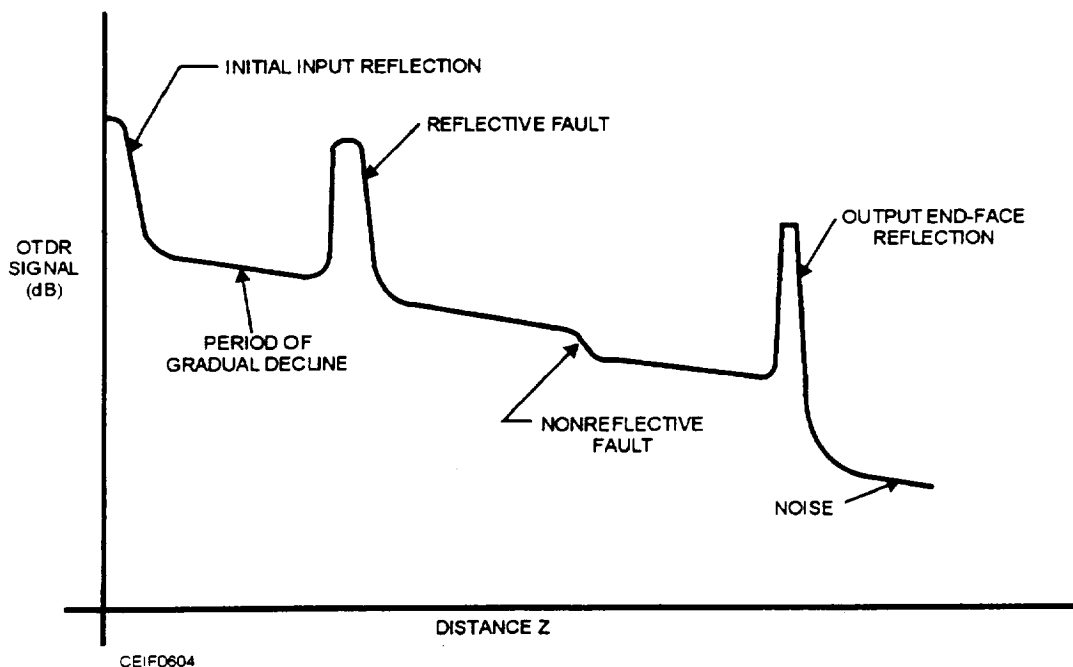

Figure 6-4.—OTDR trace of an installed cable plant.

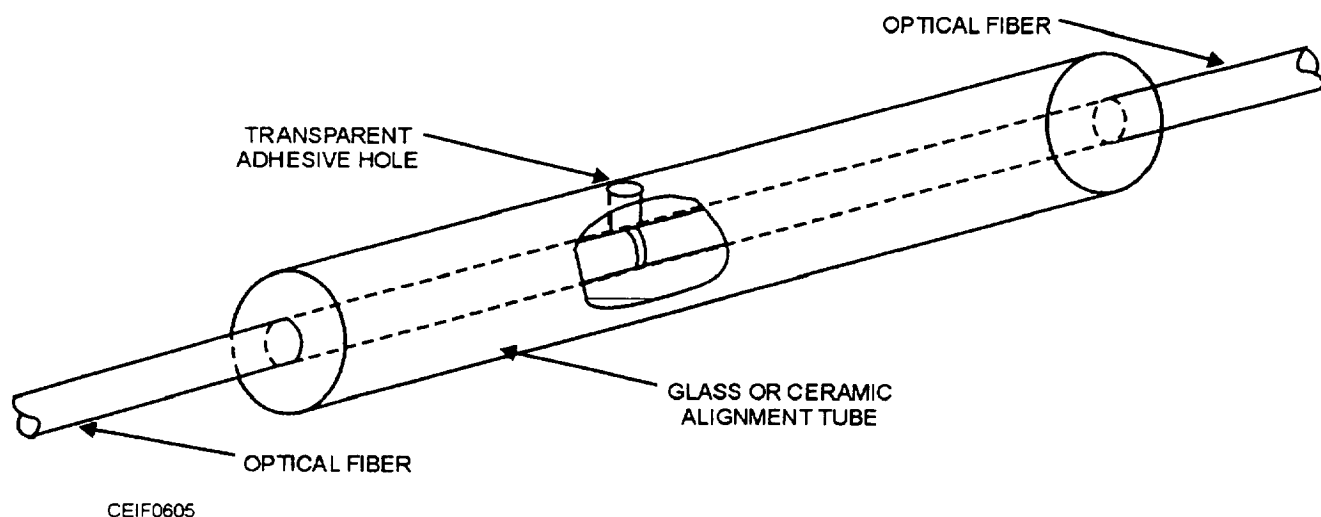

Figure 6-5.—A glass or ceramic alignment tube for mechanical splicing.

diameter of the alignment tube. If the inner diameter is too large, splice loss will increase because of fiber misalignment. If the inner diameter is too small, it is impossible to insert the fiber into the tube.

V-GROOVED SPLICES

Mechanical splices also may use either a grooved substrate or positioning rods to form suitable V-grooves for mechanical splicing. The basic V-grooved device relies on an open-grooved substrate to perform fiber alignment. When you are inserting the fibers into the grooved substrate, the V-groove aligns the cladding surface of each fiber end. A transparent adhesive makes the splice permanent by securing the fiber ends to the grooved substrate. Figure 6-6 illustrates this type of open V-grooved splice.

V-grooved splices may involve sandwiching the butted ends of two prepared fibers between a V-grooved substrate and a flat, glass plate. Additional V-grooved devices use two or three positioning rods to form a suitable V-groove for splicing. The V-grooved device that uses two positioning rods is the spring V-grooved splice. This splice uses a groove formed by two rods positioned in a bracket to align the fiber ends. The diameter of the positioning rods permits the outer surface of each fiber end to extend above the groove formed by the rods. A flat spring presses the fiber ends into the groove maintaining fiber alignment. Transparent adhesive completes the assembly process by bonding the fiber ends and providing index matching. Figure 6-7 is an illustration of the spring V-grooved splice. A variation of this splice

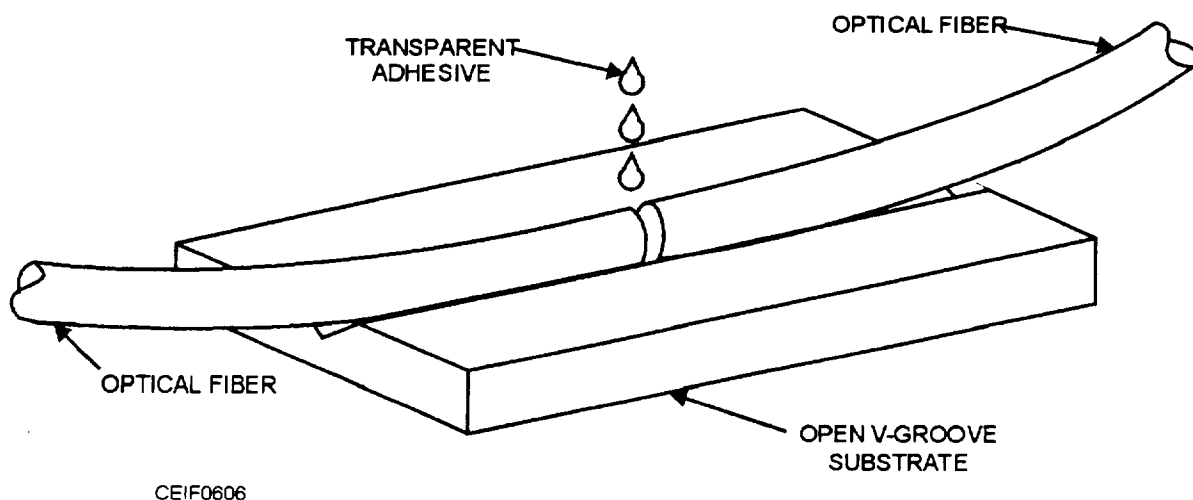

Figure 6-6.—Open V-grooved splice.

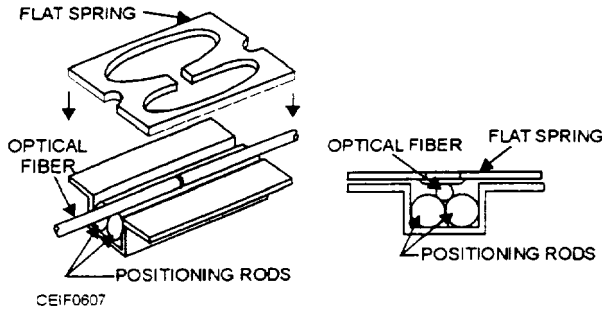

Figure 6-7.—Spring V-grooved mechanical splice.

uses a third positioning rod instead of a flat spring. The rods are held in place by a heat-shrinkable band or tube.

ROTARY SPLICES

In a rotary splice, the fibers are mounted into a glass ferrule and secured with adhesives. The splice begins as one long, glass ferrule that is broken in half during the assembly process. A fiber is inserted into each half of the tube and epoxied in place, using an ultraviolet cure epoxy. The end face of the tubes is then polished and placed together, using the alignment sleeve. Figure 6-8 is an illustration of a rotary mechanical splice. The fiber ends retain their original orientation and have added mechanical stability since each fiber is mounted into a glass ferrule and alignment sleeve. The rotary splice may use index matching gel within the alignment sleeve to produce low-loss splices.

FUSION SPLICES

The process of fusion splicing involves using localized heat to melt or fuse the ends of two optical fibers together. The splicing process begins by preparing each fiber end for fusion. Fusion splicing requires that all protective coatings be removed from the ends of each fiber. The fiber is then cleaved, using the score-and-break method. The quality of each fiber end is inspected with a microscope. In fusion splicing,

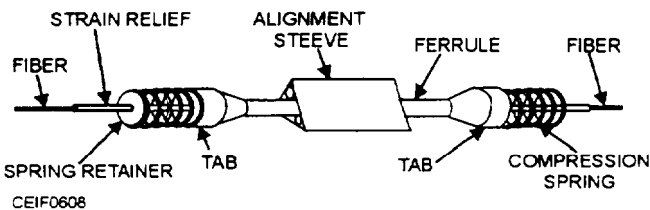

Figure 6-8.—Rotary mechanical splice.

splice loss is a direct function of the angles and quality of the two fiber end faces.

The basic fusion-splicing apparatus consists of two fixtures on which the fibers are mounted and two electrodes. Figure 6-9 shows a basic fusion-splicing apparatus. An inspection microscope assists in the placement of the prepared fiber ends into a fusion-splicing apparatus. The fibers are placed into the apparatus, aligned, and then fused together. Initially, fusion splicing used nichrome wire as the heating element to melt or fuse fibers together. New fusion-splicing techniques have replaced the nichrome wire with carbon dioxide (CO₂) lasers, electric arcs, or gas flames to heat the fiber ends, causing them to fuse together. The small size of the fusion splice and the development of automated fusion-splicing machines have made **electric arc fusion** (arc fusion) one of the most popular splicing techniques.

MULTIFIBER SPLICES

Normally, multifiber splices are only installed on ribbon type of fiber-optic cables. Multifiber splicing techniques can use arc fusion to restore connection, but most splicing techniques use mechanical splicing methods. The most common mechanical splice is the ribbon splice.

A ribbon splice uses an etched silicon chip, or grooved substrate, to splice the multiple fibers within a flat ribbon. The spacing between the etched grooves of the silicon chip is equal to the spacing between the fibers in the flat ribbon. Before you place each ribbon on the etched silicon chip, each fiber within the ribbon cable is cleaved. All of the fibers are placed into the grooves and held in place with a flat cover. Typically, an index matching gel is used to reduce the splice loss. Figure 6-10 shows the placement of the fiber ribbon on the etched silicon chip.

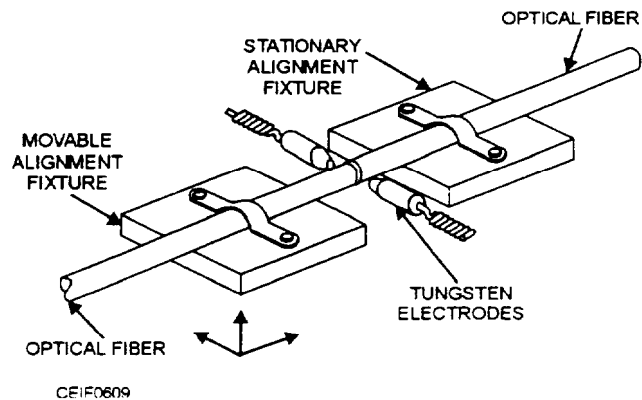

Figure 6-9.—A basic fusion-splicing apparatus.

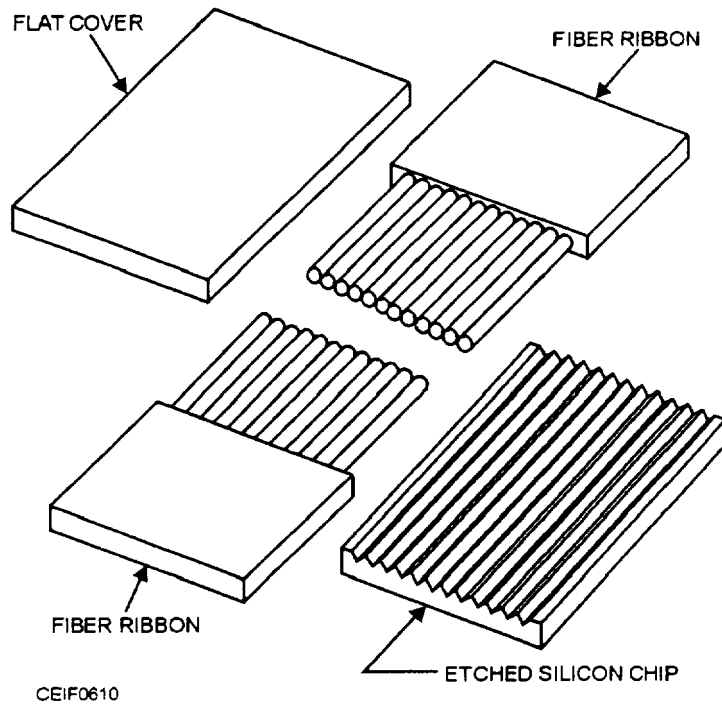

Figure 6-10.—Ribbon splice on etched silicon chip.

AREA LIGHTING SYSTEMS

Streetlighting at naval facilities usually need not produce as high a level of illumination as that required in many municipal areas. Because night activity by vehicles and pedestrians is low, only enough light is supplied to permit personnel to identify streets and buildings and to furnish sufficient visibility for local security requirements. Requirements for security and floodlighting systems will depend on the situation and the areas to be protected or illuminated.

STREET AND AREA CLASSIFICATION

Streetlighting requirements generally consist of a minimum average maintained footcandle level and a maximum allowable uniformity ratio for the installation. The authority for these requirements is the American National Standards Institute (ANSI)/Illuminating Engineering Society (IES) publication, *Standard Practice for Roadway Lighting*. Another publication that may prove helpful is *Informational Guide for Roadway Lighting*, published by the American Association of State Highway and Transportation Officials. The only significant difference between the two publications is that the latter allows a 4 to 1 uniformity ratio instead of the 3 to 1 uniformity ratio specified by IES. These uniformity ratios are defined as the ratio of the average footcandle value divided by the minimum footcandle value.

LIGHTING INTENSITY

The illumination and uniformity requirements are given in table 6-1. Note that the illumination level is dependent upon the roadway classification and the area classification that are defined in the following material.

Streets are classified into three major categories: major, collector, and local.

- **Major:** The part of the roadway system that serves as the principal network for through traffic flow. The routes connect areas of principal traffic generation and important rural highways entering the city.

- **Collector:** Distributor and collector roadways serving traffic between major and local roadways. These are roadways used mainly for traffic movements within residential, commercial, and industrial areas

- **Local:** Roadways used primarily for direct access to residential, commercial, industrial, or other abutting property. They do not include roadways carrying through traffic.

The locality or area is also defined by three major categories: commercial, intermediate, and residential.

- **Commercial:** That portion of a municipality in a business development where ordinarily there are large numbers of pedestrians and a heavy demand for parking space during periods of peak traffic or a sustained high

Table 6-1.—Roadway Illumination and Lamp Selection Guide.

Area Class	Roadways Classification	Min. Average. Maint. FC	Uniformity Avg./Min. FC/FC
Residential	Local	0.4	6:1
	Collector	0.6	3:1
	Major	1.0	3:1
Intermediate	Local	0.6	3:1
	Collector	0.9	3:1
	Major	1.4	3:1
Commercial	Collector	1.2	3:1
	Major	2.0	3:1

pedestrian volume and a continuously heavy demand for off-street parking during business hours.

- **Intermediate:** That portion of a municipality which is outside of a downtown area but generally within the zone of influence of a business or industrial development; characterized often by a moderately heavy nighttime pedestrian traffic and a somewhat lower parking turnover than is found in a commercial area. This definition includes military installations, hospitals, and neighborhood recreational centers.

- **Residential:** A residential development, or a mixture of residential and commercial establishments, characterized by few pedestrians and a lower parking demand or turnover at night. This definition includes areas with single-family homes and apartments.

SELECTION OF LUMINAIRES

Luminaires are designed to provide lighting to fit many conditions. For street and area lighting, five basic patterns are available, as shown in figure 6-11. While many luminaires can be adjusted to produce more than one pattern, no luminaire is suitable for all patterns. Care must be used, especially in repair and replacement, to install the proper luminaire for the desired pattern, as specified in the manufacturer’s literature. Even when the proper luminaire is installed, care must be used to ensure that all adjustments have been properly made to produce the desired results.

- **Type I** (fig. 6-11a) is intended for narrow roadways with a width about equal to lamp-mounting

height. The lamp should be near the center of the street. A variation of this positioning (fig. 6-11b) is suitable for intersections of two such roadways with the lamp at the approximate center.

- **Type II** (fig. 6-11c) produces more spread than does Type I. It is intended for roadways with a width of about 1.6 times the lamp-mounting height with the lamp located near one side. A variation (fig. 6-11d) is suitable for intersections of two such roadways with the lamp not near the center of the intersection.

- **Type III** (fig. 6-11e) is intended for luminaires located near the side of the roadway with a width of not over 2.7 times the mounting height.

- **Type IV** (fig. 6-11f) is intended for side-of-road mounting on a roadway with a width of up to 3.7 times the mounting height.

- **Type V** (fig. 6-11g) has circular distribution and is suitable for area lighting and wide roadway intersections. Types III and IV can be staggered on opposite sides of the roadway for better uniformity in lighting level or for use on wider roadways.

MOUNTING HEIGHT AND SPACING

There are two standards for determining a preferred luminaire mounting height: the desirability of minimizing direct glare from the luminaire and the need for a reasonably uniform distribution of illumination on the street surface. The higher the luminaire is mounted, the farther it is above the normal

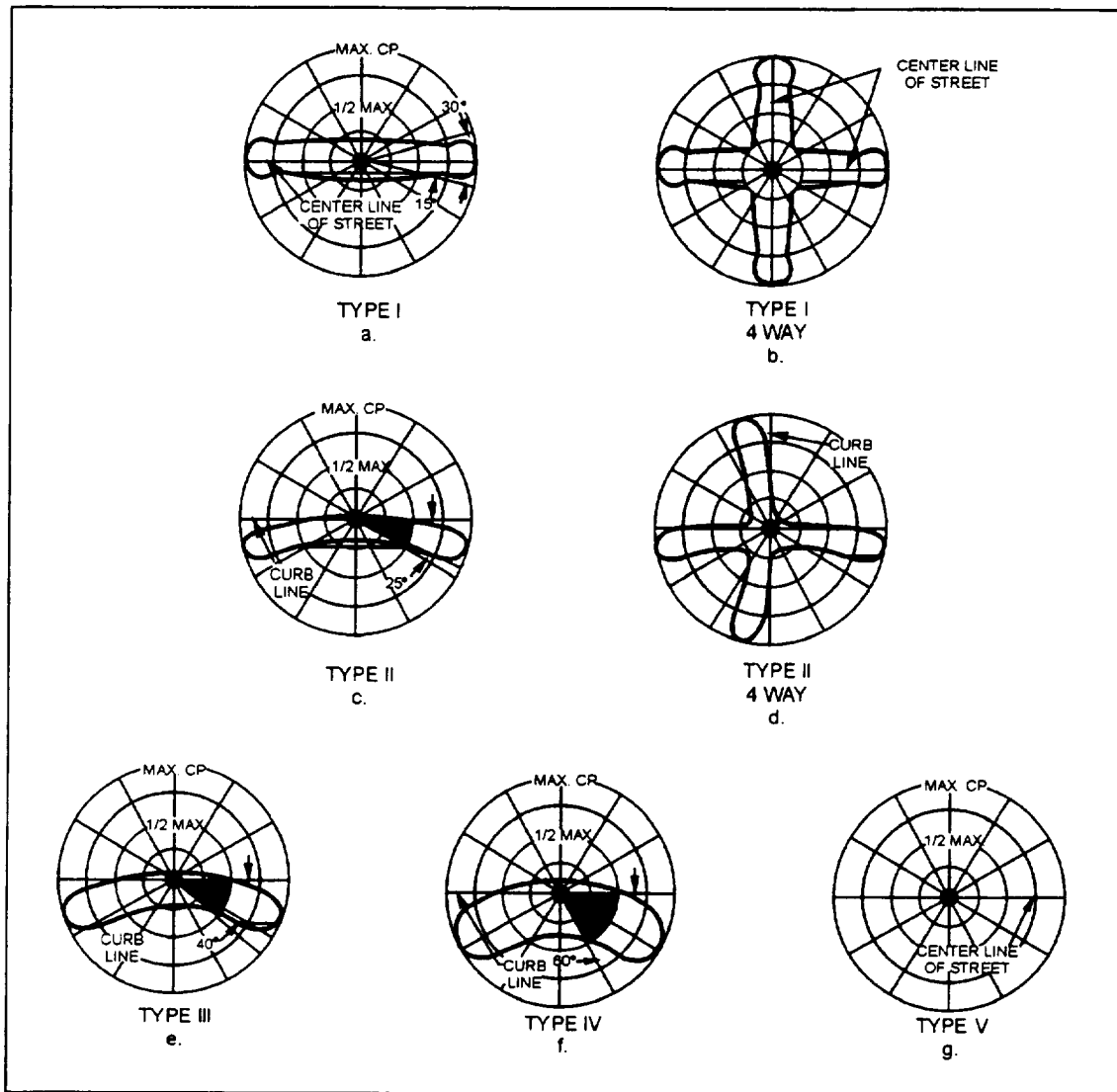

CEIF0811

Figure 6-11.—Light distribution patterns for roadway lighting.

line of vision and the less glare it creates. Greater mounting heights may often be preferable, but heights less than 20 feet cannot be considered good practice.

You must be somewhat familiar with the terminology relating to how fixtures are located down a roadway. Figure 6-12 shows these relationships graphically. The following information will be useful when determining the most appropriate mounting arrangements:

- The “transverse direction” is defined as back and forth across the width of the road, and the “longitudinal direction” is defined as up and down the length of the road.
- Modern roadway fixtures are designed to be mounted in the vicinity of one of the curbs of the road.

The “overhang” is defined as the dimension between the curb behind the fixture and a point directly beneath the fixture.

- A luminaire overhang should not exceed 25 percent of the mounting height.
- No attempt should be made to light a roadway that is more than twice the width of the fixture-mounting height. A roadway luminaire produces a beam in both longitudinal directions and is limited in its ability to light across the street.
- There are three ways that a luminaire may be positioned longitudinally down the roadway (fig. 6-12). Note that the spacing is always the dimension from one fixture to the next down the street regardless of which side of the street the fixture is located.

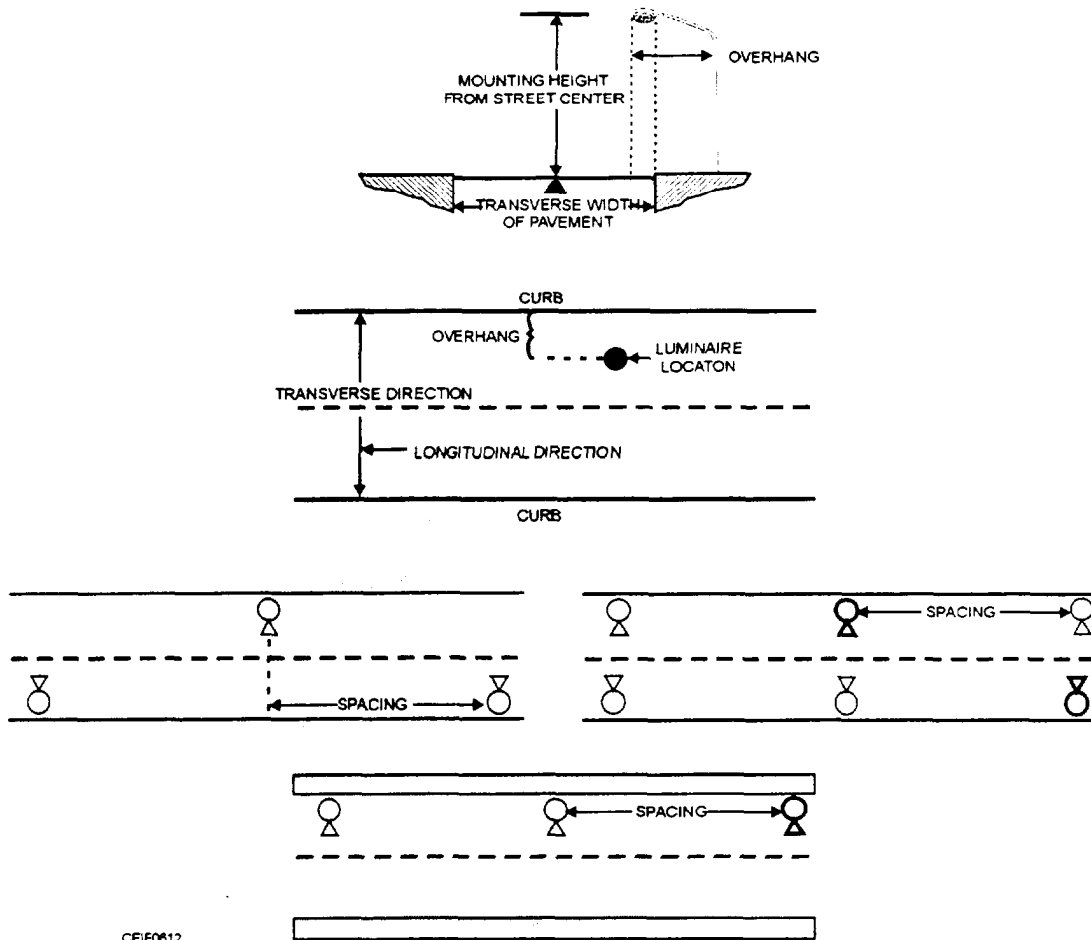

CEIF0612

Figure 6-12.—Luminaire arrangement and spacing.

- A staggered arrangement generates better uniformity and possibly greater spacing than a one-side arrangement. That is particularly true when the width of the road becomes significantly greater than the mounting height. When the width of the road starts approaching two mounting heights, an opposite arrangement definitely should be considered. That would, in effect, extend the two-mounting-height width limitation out to four-mounting heights.

The classification of a road and the corresponding illumination levels desired influences the spacing between luminaires. On a residential road, it may be permissible to extend the spacing so that the light beams barely meet (fig. 6-13). For traffic on business roadways where uniformity of illumination is more important, it may be desirable to narrow the spacing to provide 50-to 100-percent overlap.

MANUFACTURER'S LITERATURE

The performance specifications of each model, type, and size of luminaire are provided with the

fixture or obtained from the manufacturer's ordering information. A working knowledge of this information will assist you in selecting and installing the correct luminaire to accomplish the job. Manufacturers provide technical literature for every luminaire they make. This literature includes utilization and isofot candle curves. These curves are important in calculating the lighting intensity of a particular luminaire. Figure 6-14 is a sample of manufacturer's literature for a 250- or 400-watt light fixture.

Utilization Curve

The utilization curve (fig. 6-14A), a measure of luminaire efficiency, shows the amount of light that falls on the roadway and adjacent areas. The amount of light that is usable or actually falls on the area to be lighted is plotted as a percentage of the total light generated in the luminaire for various ratios of transverse distance (across the street from the luminaire on both the house side and street side) to the mounting height (fig. 6-15). The coefficient of

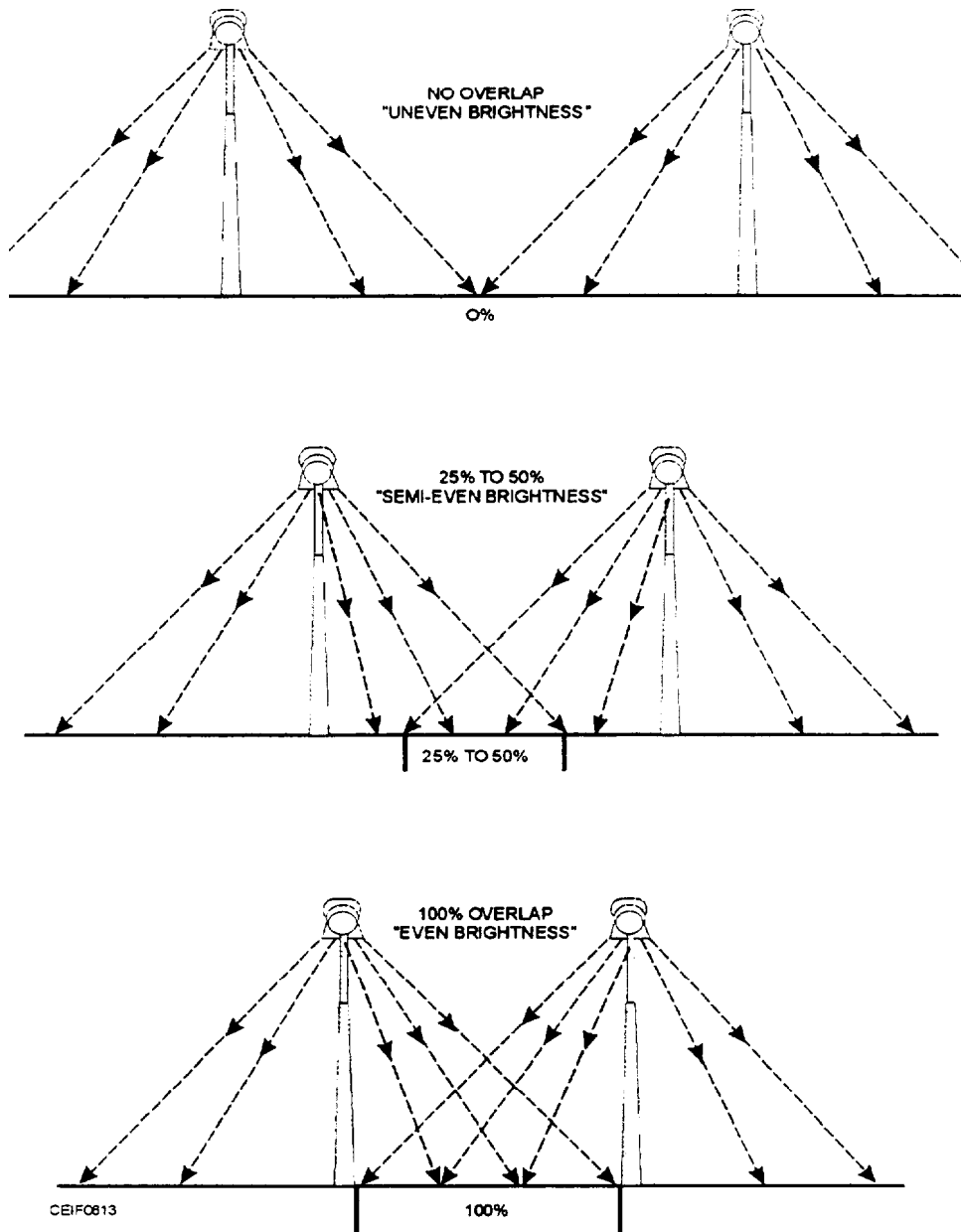

Figure 6-13.—Pavement brightness.

utilization for any specific situation is obtained from this curve. The utilization curve will determine the amount of light that actually strikes the roadway surface. This percentage of light has an impact on the spacing distance of the luminaires.

Isofootcandle Curve

The isofootcandle diagram (fig. 6-14B) shows the distribution of illumination on the road surface in the vicinity of the luminaire.

The lines on this diagram connect all points having equal illumination, much as the contour lines on a topographical map indicate all points having the same

elevation. Thus, at any point on the diagram (or roadway), we know the magnitude and direction of the illumination with respect to nearby points. To make this data more universal, you are given both the top horizontal and left vertical axes in terms of mounting-height ratios.

It is sometimes convenient for you to replot the isofootcandle data to the same scale as that used on a drawing containing a lighting layout. By superimposing this diagram, you can study the distribution of light. Under the unity correction factor in the mounting-height table (fig. 6-14B), one can find the mounting height for which the data are calculated. The numbers beside each line represent the initial

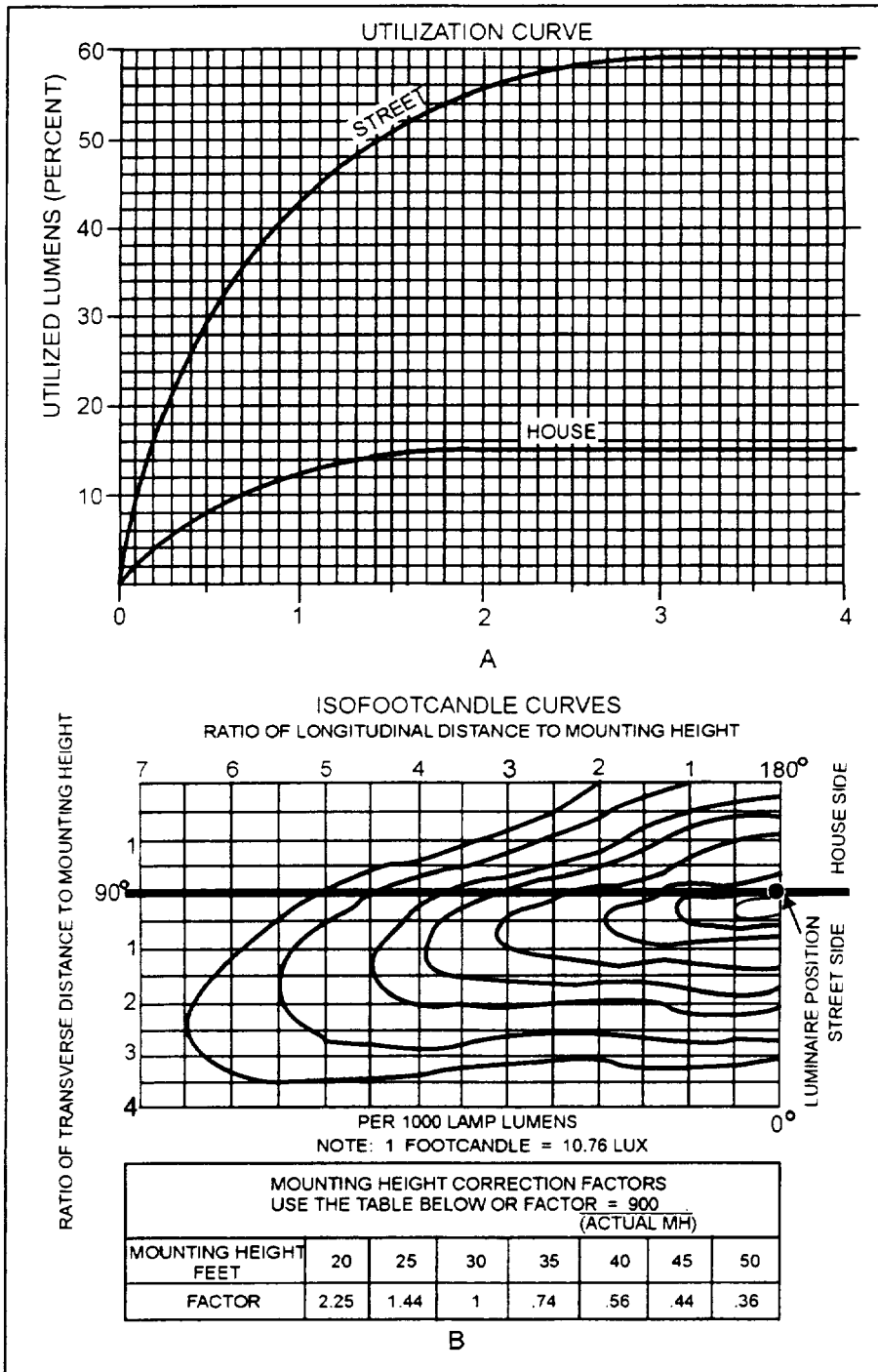

CEIF0614

Figure 6-14.—Streetlight manufacturer's literature.

footcandle values per 1,000 lamp lumens. Each footcandle value must be multiplied by 50 to obtain the correct footcandle value on the isofootcandle diagram. This ratio of actual lamp lumens divided by 1,000 is known as the lamp factor (LF). Note that the lamp factor allows a curve to represent the distribution from more than one lamp wattage; for example, from 250- and 400-watt lamps.

Maintenance Factor

Lighting efficiency is seriously impaired by blackened lamps, by lamp life, and by dirt on the reflecting surfaces of the luminaire. To compensate for the gradual loss of illumination, you must apply a maintenance factor (MF) to the lighting calculations.

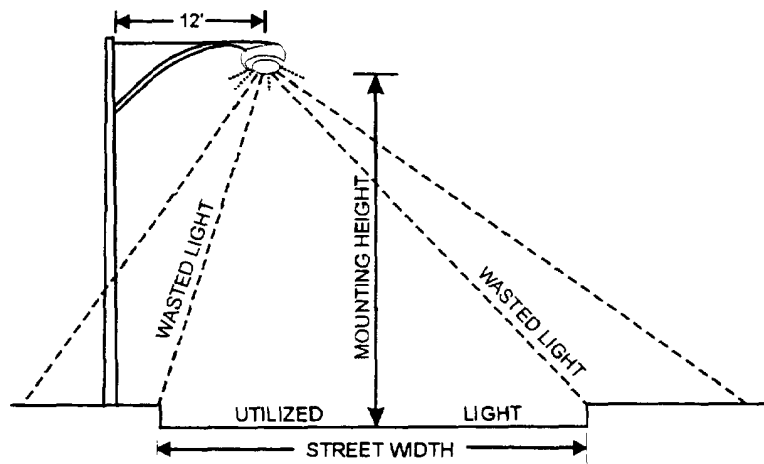

CEIF0615

Figure 6-15.—Luminaire utilization.

Normally, each luminaire manufacturer can supply you with the maintenance factor for your lamp model; however, when the manufacturer's information is not available, a 0.70 maintenance factor is widely used in the industry.

LIGHTING INTENSITY CALCULATIONS

Achieving the most satisfactory solution for any given lighting problem requires sound judgment in making necessary compromises of all factors involved.

Selection of the luminaire can be influenced by budget constraints, present stock levels in the Federal Supply System, and availability. Once the luminaire is selected, it is important that you use the manufacturer's

literature to determine the number of luminaires, mounting height, and spacing required to produce the desired illumination intensity.

Using the manufacturer's literature supplied in figure 6-14, let us solve this sample problem:

Find:

1. One-sided spacing required to provide specified illumination
2. Uniformity of illumination

Given: (fig. 6-16)

- Street width, 50 feet
- Mounting height, 40 feet
- Pole setback from curb, 2 feet

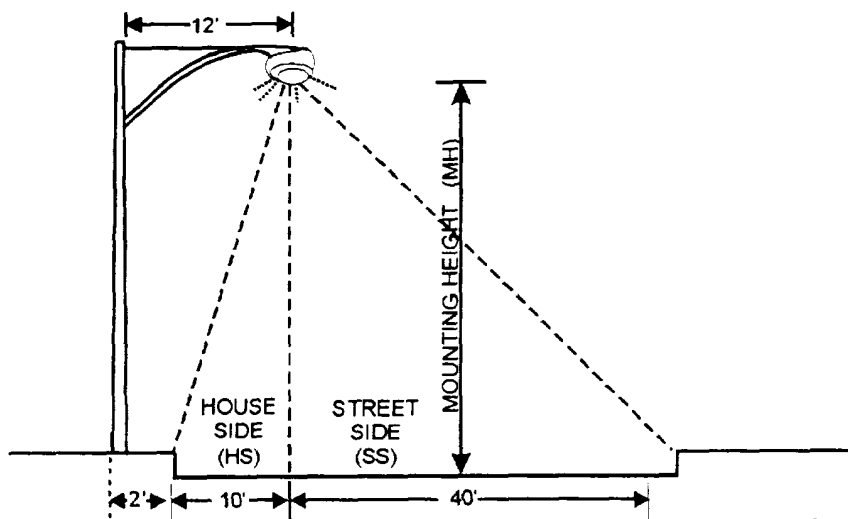

CEIF0616

Figure 6-16.—Streetlight sample problem.

- Bracket length, 12 feet
- Required average maintained level of illumination, 2 footcandles
- 400-watt luminaire (50,000 lamp lumens)

Solution:

1. Spacing. The equation to determine correct spacing is

$$Spacing (S) = \frac{(LL)(MF)(CU)}{(fc)(W)}$$

Where:

LL = rated initial lamp lumens

MF = maintenance factor

CU = coefficient of utilization

fc = illumination in footcandles

W = street width, curb to curb

The values are given for LL (50,000), MF (assume 0.70), W (50), and fc (2). After a value for CU is determined, you can solve the equation for average spacing.

To determine the coefficient of utilization, calculate the amount of wasted light on the street side (SS) and the house side (HS) where:

$$Ratio\ of\ HS = \frac{Transverse\ Distance}{Mounting\ Height} = \frac{10}{40} = 0.25$$

$$Ratio\ of\ SS = \frac{Transverse\ Distance}{Mounting\ Height} = \frac{50-10}{40} = \frac{40}{40} = 1.0$$

From the utilization curve in figure 6-17, the ratio of 1.0, street side, corresponds to 40 percent, and the ratio of 0.25, house side, corresponds to 3 percent, for a total of 43 percent CU.

Spacing can be determined as

$$S = \frac{(50,000)(0.70)(0.43)}{(2)(50)} = 150\ feet.$$

2. Uniformity.

The uniformity of illumination is expressed in terms of a ratio of

$$\frac{Average\ fc}{Minimum\ fc}$$

It has been determined that one-side spacing of 150 feet will produce an average of 2 footcandles on the roadway surface. The point of minimum illumination can now be determined from the isofootcandle diagram.

The minimum value of the illumination can be found by studying the isofootcandle diagram and taking into account all luminaires that are contributing significant amounts of light. Generally, the minimum value will be found along a line halfway, between two consecutively spaced luminaires. The minimum value can be determined by checking the minimum footcandle values at points P1, P2, and P3, as shown in figure 6-18.

The roadway surface can be plotted on the isofootcandle curve by observing the 40-foot mounting height to longitudinal and transverse distance ratios. (See fig. 6-19.) Since P1 is located outside the 0.02 footcandle line, it is the lowest total footcandle value. This value would be 0.03 fc (0.015 footcandle from each luminaire).

Figure 6-20 shows a perspective view of the two isofootcandle lines that are considered when determining the illumination value at P1.

The following factors are now applied to this "raw" footcandle value, as shown in the formula:

$$fc\ min = (fc)(LF)(MF)(CF)$$

Where:

fc min = minimum point footcandles

fc = raw footcandle from isofootcandle diagram

LF = lamp factor

MF = maintenance factor

CF = mounting height correction factor

The values are given for fc (0.03) and MF (assume 0.70). The value for LF was determined earlier as 50 for the 400-watt lamp. The CF factor can be determined from the correction chart below the isofootcandle curve in figure 6-14. The CF for a 40-foot mounting height is 0.56.

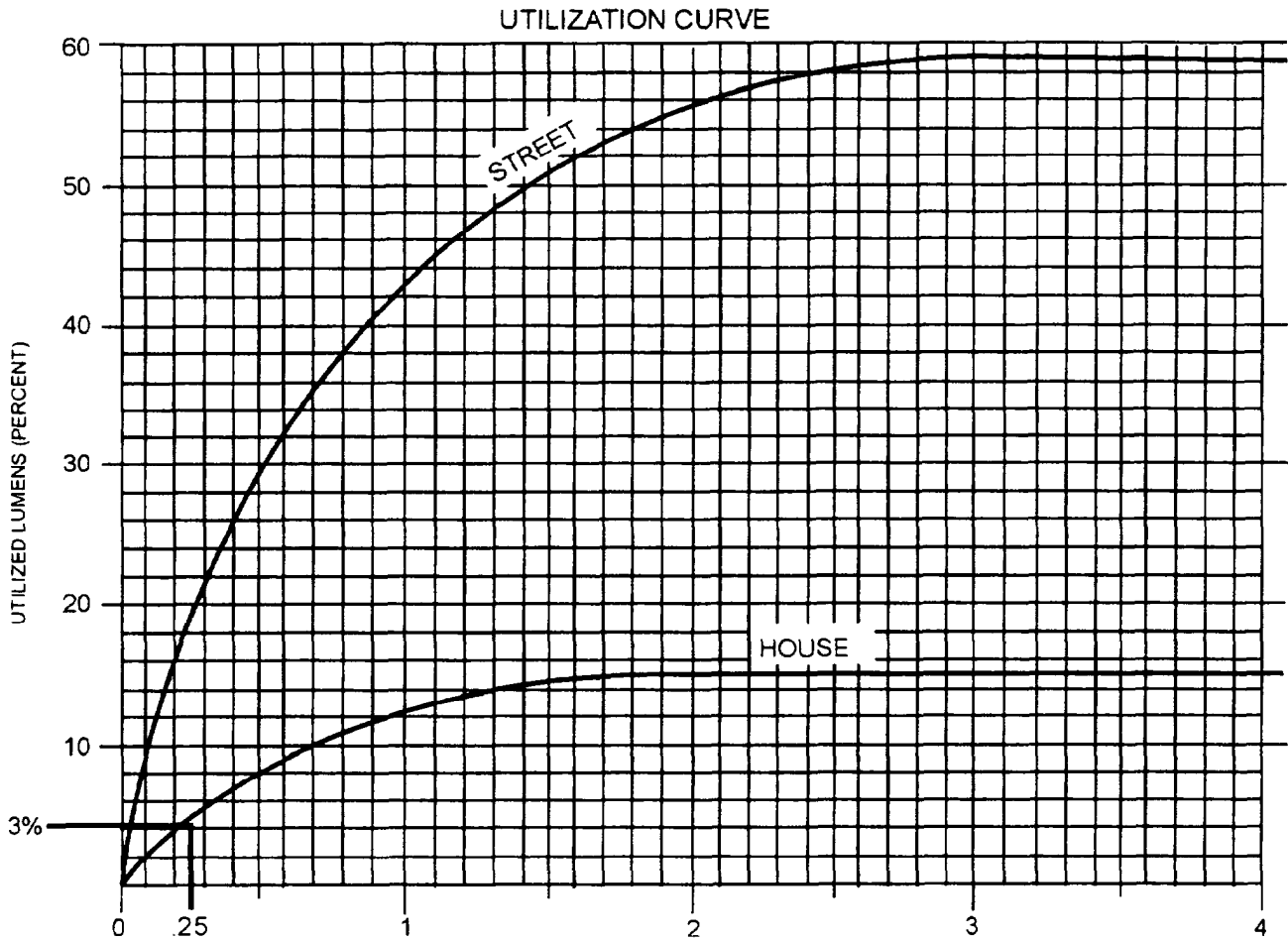

Figure 6-17.—Utilization curve

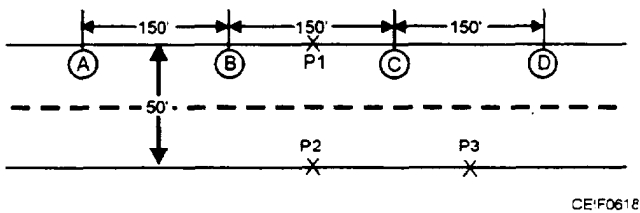

Figure 6-18.—Streetlight layout.

The minimum point footcandies are
 $fc_{min} = (0.03) (50) (0.70) (0.56) = 0.58$

Therefore, the average-to-minimum ratio of uniformity would be

$$\frac{2 fc}{0.58 fc} = 3.40$$

A uniformity ratio of 3.40 meets the ANSI/IES recommended roadway illumination levels (table 6-1) for a major, commercial roadway.

FLOODLIGHTS

Streetlighting systems usually give lighting intensity from .01 to 0.5 footcandle; however, this value is too low for any night activity requiring good visibility. Figure 6-21 gives recommended illumination intensities for specific night activities. The following suggestions should be followed to improve the efficiency of floodlighting systems:

- Select floodlight locations so beams strike the surface to be illuminated as nearly perpendicular as possible.
- When lighting irregular surfaces, use two or more floodlights to reduce sharp shadows caused by surface contour.
- For lighting extended horizontal surfaces, such as work areas, mount floodlights high enough to minimize glare.

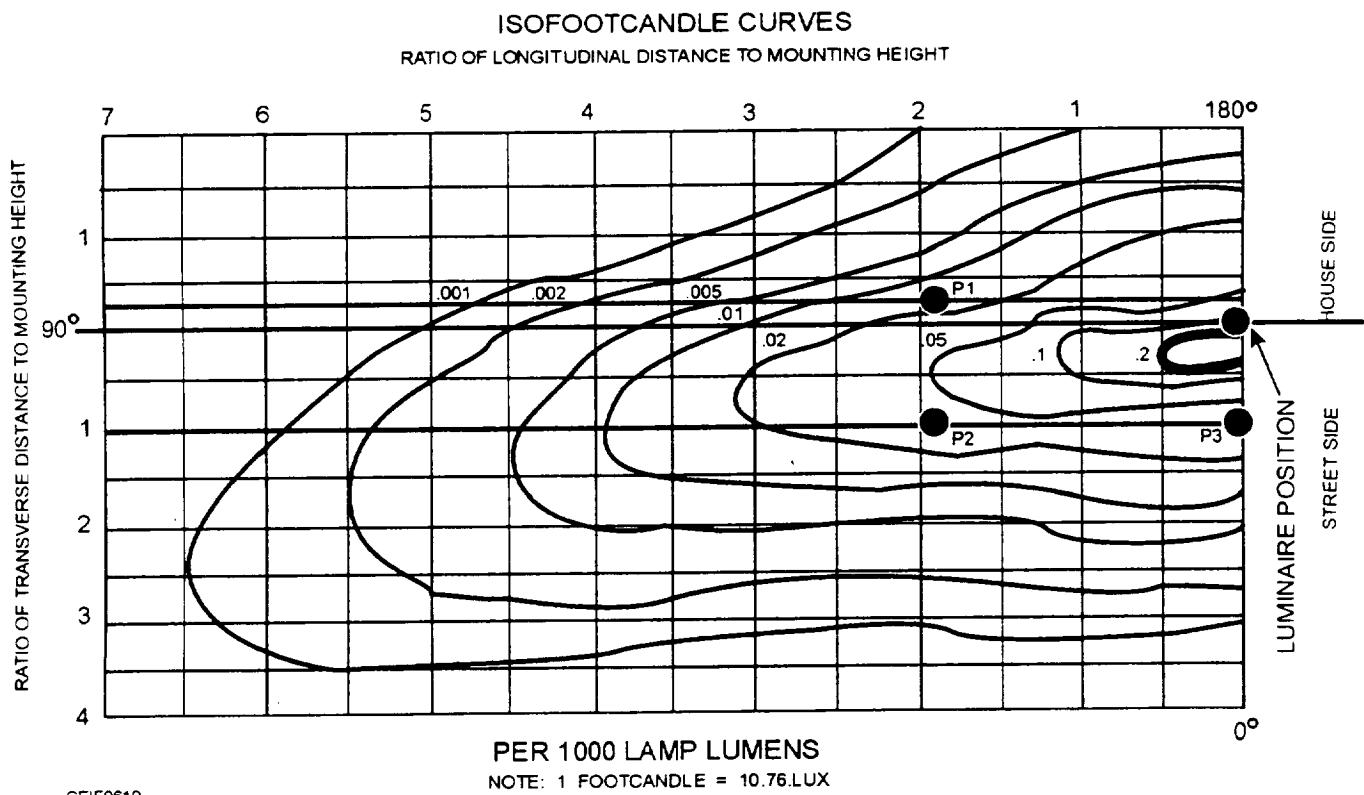

Figure 6-19.—Isofootcandle curve.

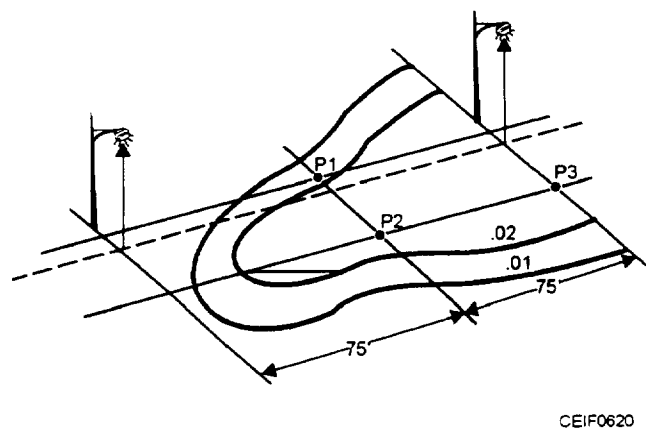

Figure 6-20.—Roadway perspective view.

- For lighting extended vertical surfaces, such as smoke stacks or towers, mount floodlights so distance between floodlights or groups does not exceed twice the distance from the floodlight to the illuminated surface.

- Use a smaller number of large floodlights instead of a larger number of smaller floodlights.

SELECTION OF LUMINAIRES

The National Electrical Manufacturer's Association (NEMA) has classified floodlighting luminaires into four classes according to construction:

1. Class HD (Heavy Duty)—Enclosed with an outer housing into which is placed a separate and removable reflector, or an enclosure in which a separate housing is placed over the reflector

2. Class GP (General Purpose)—Enclosed with a one-piece housing with the inner surface serving as a reflector and the outer surface being exposed to the elements

3. Class O (Open)—One-piece housing without cover glass

4. Class OI—Same as Class O except with an auxiliary inner reflector to modify the beam

The suffix letter "B" should be added to the above class designations to indicate when an integral ballast is required.

Example: A heavy-duty floodlight with an integral ballast would be designated as a Class HDB floodlight.

GENERAL APPLICATION	MINIMUM AVERAGE RECOMMENDED FOOTCANDLES		
	CITY	SUBURBAN	RURAL
BUILDING EXTERIORS - Terra cotta, light marble or plaster - Bedford or buff limestone, smooth buff face brick, concrete, aluminum - Smooth or medium gray brick, common tan or dark field gray brick - Brownstone, stained wooden shingles or other dark surfaces	15	10	5
	20	15	10
	30	20	15
	50	35	20
CONSTRUCTION - General - Excavation	10 2		
INDUSTRIAL ROADWAYS - Adjacent to buildings - Not bordered by buildings	10 05		
INDUSTRIAL YARD / MATERIAL HANDLING AREA	5		
LOADING / UNLOADING PLATFORMS, FREIGHT DOCKS	20		
PARKING AREAS - Industrial - Shopping centers - Commercial lots	10 2 - 5 2 - 5		
SHIPYARDS - General - Ways - Fabrication areas	5 10 30		
* Outdoor recreational and sporting facilities should be based on Illuminating Engineering Society publications.			
All values are considered to be footcandles and are in terms of horizontal-plane. Higher levels of illumination may be required for safety.			

CEI#0621

Figure 6-21.—Recommended intensities for specific night activities.

The beam spread can be described in degrees or by NEMA types (table 6-2). The beam spread is based on the angle to either side of the aiming point where the candlepower drops to 10 percent of its maximum value. The lamp and floodlight NEMA type is given in the upper left-hand corner of each isofootcandle diagram.

The NEMA type should only be used as a reference. It does not describe the shape of the light pattern the floodlight produces or the peak illumination level (footcandles). Symmetrical floodlights have the same horizontal and vertical beam spread and are classified with one NEMA number. Asymmetrical beam spreads have a horizontal (H) and

a vertical (V) designation. The horizontal value is always given first.

$$\text{Example: NEMA TYPE } \frac{H}{7} \times \frac{V}{6}$$

MOUNTING HEIGHT AND SPACING

The size of the area to be illuminated has a direct effect on determining the number and spacing of the poles. The suggested area that can be covered by a single pole is four times the mounting height. That is known as the “2X-4X” rule (fig. 6-22).

Areas lighted from interior poles or other central locations (fig. 6-22A) can be more economical, but

Table 6-2.—Luminaire Designations

			Min. Beam Efficiency %	
Beam Spread Degrees	NEMA Type Designation	Beam Description	Incandescent, Tungsten, Halogen	High-Intensity Discharge
10 up to 18	1	very narrow	38	
18 up to 29	2	narrow	30	30
29 up to 46	3	medium narrow	46	34
46 up to 70	4	medium	50	38
70 up to 100	5	medium wide	54	42
100 up to 130	6	wide	56	46
130 and up	7	very wide	60	50

perimeter locations are also desirable to provide needed visibility at entrances and exits. in the case of perimeter poles (fig. 6-22B), if corner locations are not used, the distance from any side location to the edge of the area should not exceed twice the mounting height. If building-mounted luminaire locations are limited to only one side of the area to be lighted (fig. 6-22C), the system will be effective for a distance of only two mounting heights unless glare is not a determining factor.

According to the 2X-4X rule, the spacing is determined to be, from the corner to the first pole, two times the mounting height(X). The next pole is set four times this mounting height (X), and the CE will continue in this manner until reaching the last pole, which also is to be set two times the mounting height from the far corner. This rule can be used to calculate the minimum number of poles. For long, narrow areas, it is better to choose several short poles than one tall one, especially since pole costs increase substantially above 40 feet. It is wise to consider several alternatives, however. to determine the system with the lowest cost.

If the pole is located inside the area to be lighted, there should be at least three floodlights or two streetlights per pole. For one side perimeter mounting, there should be two floodlights or one streetlight per pole.

FLOODLIGHT AIMING

When a fixture is aimed at the surface at an angle other than perpendicular, the maximum lighting level will always occur behind the aiming point, or point of maximum candela. That is important to know when the fixtures are placed close to the base of a tall structure. In this case, the highest lighting level will occur at the base, even though the fixture is aimed at the top.

For vertical aiming, the aiming point should be two thirds to three fourths of the distance across the area or twice the mounting height, whichever is the lowest value. Higher aiming angles will not improve utilization and uniformity. (See fig. 6-23.)

The highest light level (vertical and horizontal) a floodlight can produce at a distance from the pole occurs when the maximum intensity or candlepower is aimed to form approximately a three, four, five triangle. (See fig. 6-24.) That is useful when determining pole height for area lighting or setback for building floodlighting.

Floodlights with NEMA 6 or 7 horizontal beams will effectively light an area 45 degrees to either side of the aiming line. In figure 6-25, the perimeter pole needs at least two floodlights to cover the area in all directions. Narrower beam floodlights require less separation to achieve uniform lighting.

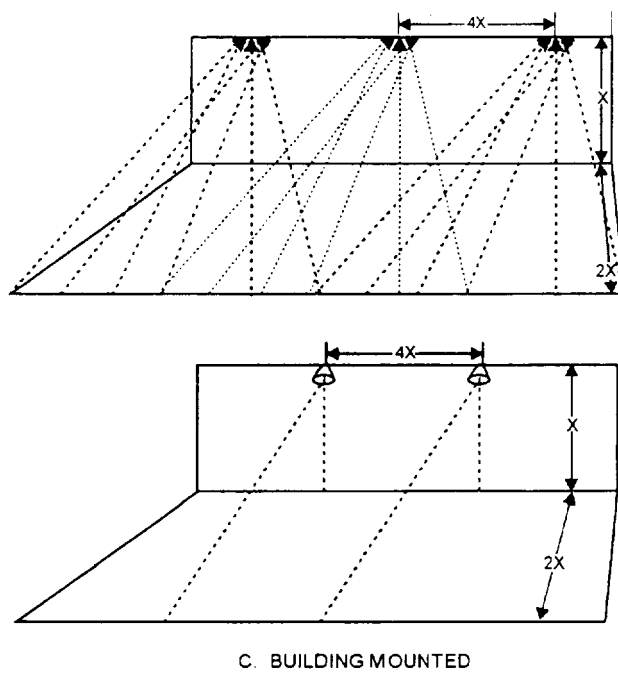
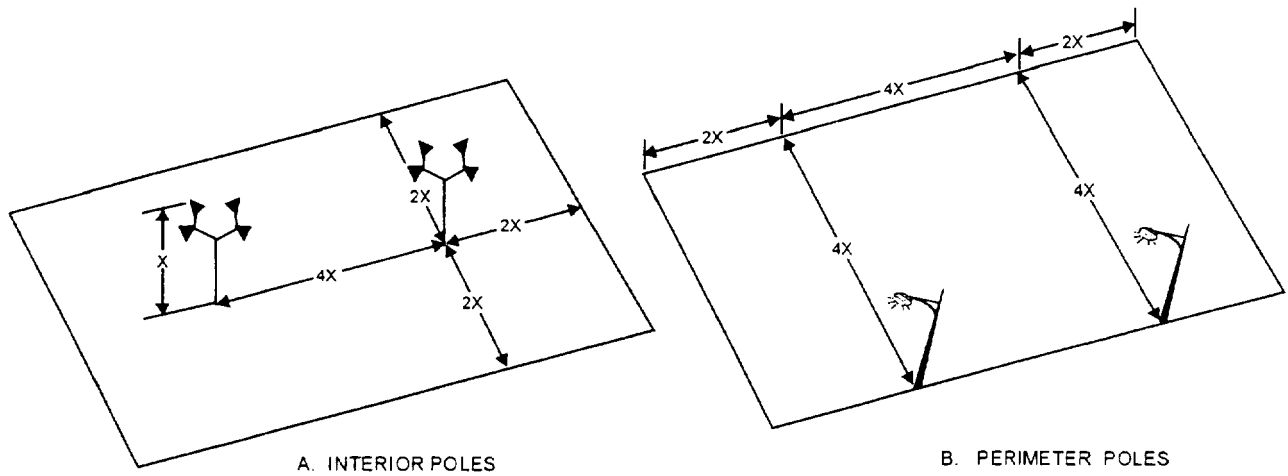

CEIF0622

Figure 6-22.—2X-4X mounting height rule.

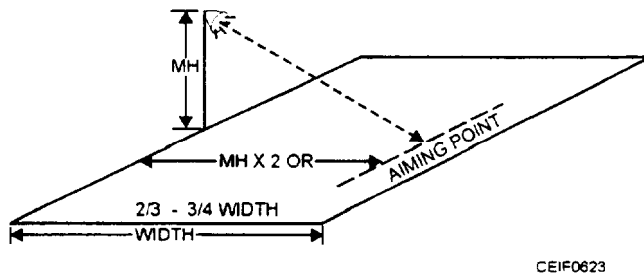

CEIF0623

Figure 6-23.—Vertical aiming.

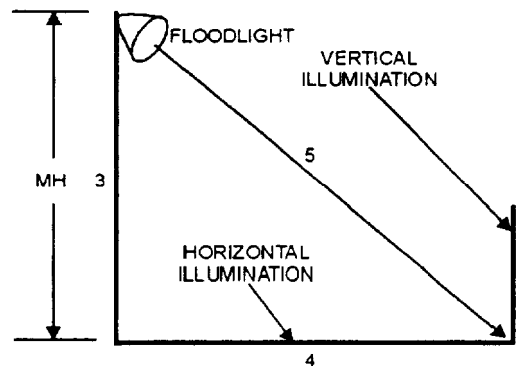

CEIF0624

Figure 6-24.—Maximum candlepower of illumination.

NEMA TYPE	HORIZONTAL BEAM SPREAD	SUGGESTED MAX. AIMING LINE SEPARATION
2	18° - 29°	12°
3	29° - 46°	24°
4	46° - 70°	40°
5	70° - 100°	60°
6	100° - 130°	90°
7	130°	120°

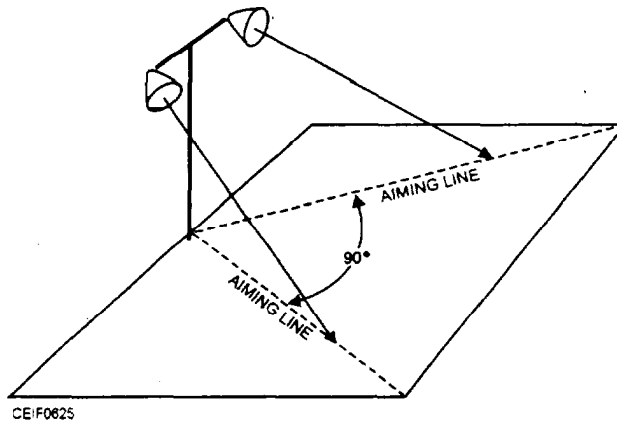

Figure 6-25.—Horizontal aiming.

Select lighting fixtures with a beam spread greater than the area being lighted. When several units are required, good lighting overlap occurs when the edge of the beam of one fixture coincides with the aiming point of the adjacent fixture.

By examining the shape (beam spread) of the lighting pattern emitted by the fixture, you can begin the process of selecting the NEMA type of floodlight best suited for the application.

Horizontal and vertical lumen distribution is stated on each photometric test. Generally, the more concentrated the luminous intensity (candela), the tighter the beam spread; for instance, the NEMA Type 2 Power Spot[®] floodlight has a beam spread of 22-degrees horizontal by 21-degrees vertical; whereas, a NEMA Type 5 has a beam spread of 77-degrees horizontal by 77-degrees vertical. The isofootcandle diagrams shown in figure 6-26 compare 1,000-watt metal halide Power Spot[®] luminaires of NEMA Type 2 and Type 5 when each luminaire is aimed out a distance of twice its mounting height.

The initial footcandle level at the aiming point of different NEMA types varies a great deal; for example, assume that each luminaire is mounted at a 50-foot mounting height and aimed 100 feet (2 x MH) directly in front of its location. If you are using a NEMA Type 2 distribution, the approximate initial footcandle level at that point would be 20; however, if you are using a NEMA Type 5 distribution, the initial footcandle level would be approximately 1.5.

By understanding the intensity of the lighting pattern, you can now appreciate the need for a range of distribution patterns.

MANUFACTURER'S LITERATURE

The performance specifications of each model, type, and size of luminaire are provided with the fixture or obtained from the manufacturer's ordering catalog. A working knowledge of this information will assist you in selecting and installing the correct floodlight to accomplish the job. Figure 6-27 shows a sample of manufacturer's literature for a 250- to 1,000-watt light fixture.

INITIAL FC TABLE			
	MOUNTING HEIGHT		
	40	50	60
A	0.16	0.1	0.07
B	0.31	0.2	0.14
C	0.78	0.5	0.35
D	1.6	1.0	0.69
E	3.1	2.0	1.4
F	7.8	5.0	3.5
G	15.6	10.0	6.9
H	31.2	20.0	13.9

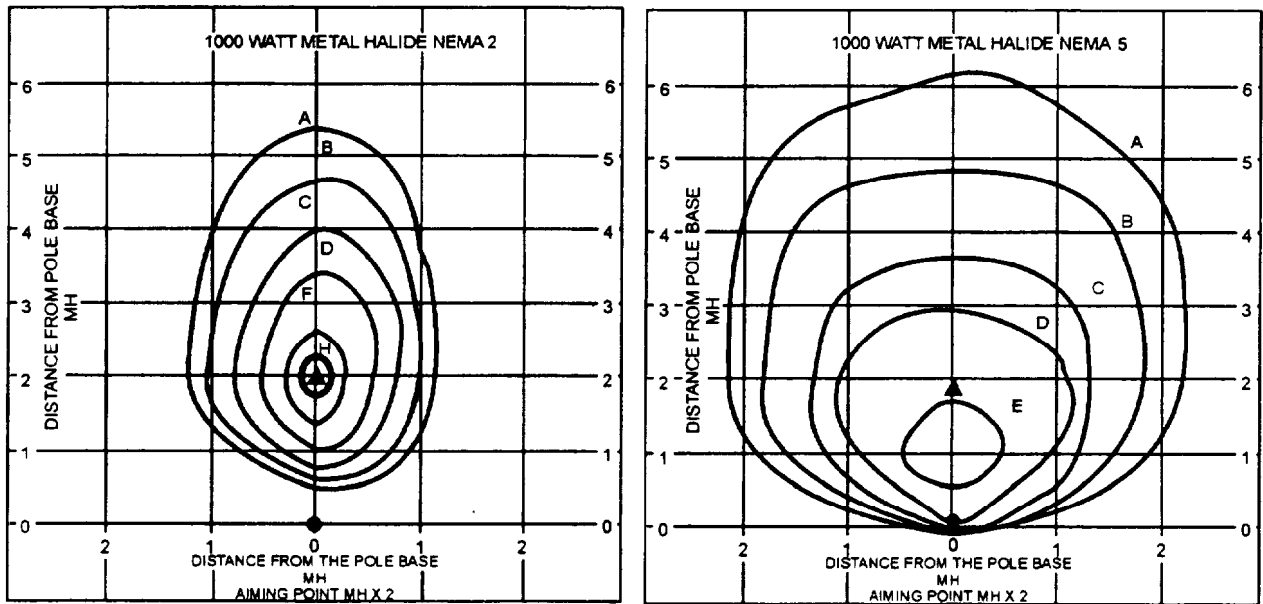

CEIF0626

Figure 6-26.—Isofootcandle diagrams.

ISOFOOTCANDLE DIAGRAMS

The isofootcandle diagrams show what the light level will be at any given point. The dimensions for the diagram are based on the mounting height (MH) of the floodlight. The aiming point (▲) is also based on the mounting height. Figure 6-27 provides a diagram for mounting heights of MH x 0.5, MH x 1, and MH x 2.

The grid pattern is also based on the mounting height. The grid line values left and right give the distance to either side of the floodlight. The values up

the side show the distance in line with the aiming direction of the floodlight. The number 3, for instance, represents 3 x 40, or 120, feet from a 40-foot mounting height.

Each isofootcandle line shows where the footcandle level is the same. These lines are identified by a letter, which is used with the initial footcandle (fc) table. The footcandle values between isofootcandle lines do not change more than 2 to 1. That makes it possible to approximate the level between lines.

INITIAL FC TABLE LU 250 watt			
	30	40	50
A	0.05	0.33	0.02
B	0.11	0.06	0.04
C	0.31	0.17	0.11
D	0.61	0.34	0.22
E	1.2	0.69	0.44
F	3.1	1.7	1.1
G	6.1	3.4	2.2
H	9.2	5.2	3.3

INITIAL FC TABLE LU 400 watt			
	30	40	50
A	0.10	0.06	0.04
B	0.22	0.13	0.08
C	0.56	0.31	0.2
D	1.1	0.63	0.4
E	2.2	1.3	0.8
F	5.6	3.1	2.0
G	11.1	6.4	4.0
H	16.7	9.4	6.0

INITIAL FC TABLE LU 1000 watt			
	40	50	60
A	0.16	0.1	0.07
B	0.31	0.2	0.14
C	0.78	0.5	0.35
D	1.6	1.0	0.69
E	3.1	2.0	1.4
F	7.8	5.0	3.5
G	15.6	10.0	6.9
H	23.4	15.0	10.4

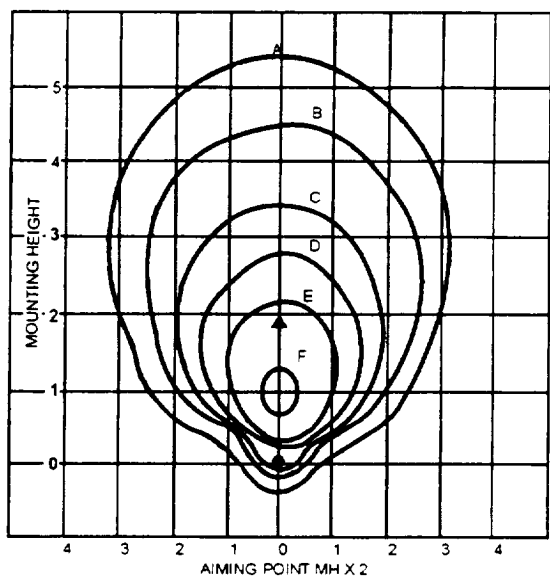
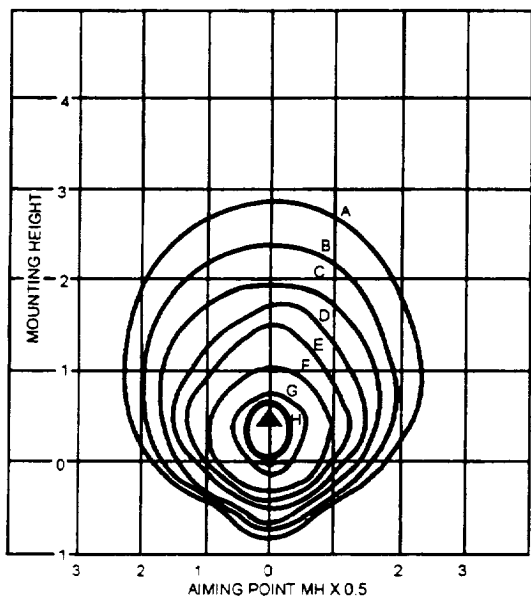
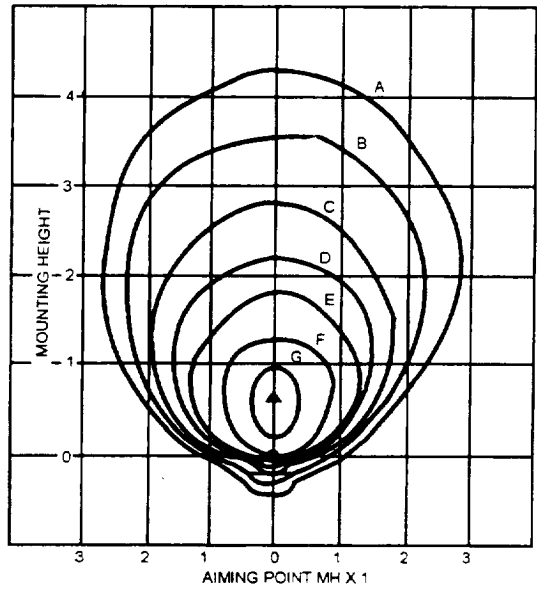
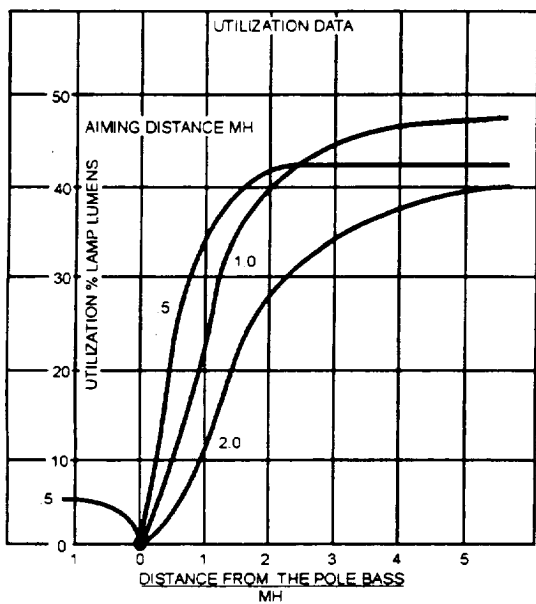

CEIF0627

Figure 6-27.—Floodlight manufacturer's literature.

The initial footcandle table gives the footcandle value for each isofootcandle curve at a specific mounting height. The values for each letter are the same on each set of curves. That makes it possible to compare diagrams directly and interpolate between curves for different aiming distances.

The mounting heights given in the initial footcandle table are representative of the wattage and beam pattern associated with the floodlight. To convert to other mounting heights, use the following formula:

OLD	NEW
(FROM CHART)	(FROM CALCULATION)
$(fc)(MH^2)$	$(fc)(MH^2)$

For example, a 5-footcandle level at 50 feet (isofootcandle curve F) would have a value of 4.13 at a 55-foot mounting height.

$$(5)(50^2) = (fc)(55^2)fc = 4.13$$

In figure 6-27 (aiming point $MH \times 2$), the floodlight is aimed a distance of two mounting heights away from a point on the ground directly below the floodlight. That would be 80 feet for a 40-foot mounting height.

UTILIZATION GRAPH

The luminaire utilization data graph (fig. 6-27) gives the percentage of the initial lamp lumens that fall into the area being lighted. Knowing this, you can easily determine the average lumens per square foot, or footcandles.

The number beside each curve identifies the aiming point, so that the utilization curve can be identified with the associated isofootcandle diagrams. In the example, for instance, the floodlight aimed two mounting heights away from the pole would have a utilization of 35 percent if it were lighting an area three mounting heights wide. The same floodlight aimed at one mounting height away from the pole would have a utilization of 45 percent for the same area.

MAINTENANCE FACTOR

Lighting efficiency in floodlighting, as in streetlighting, is seriously impaired by blackened lamps, by lamp life, and by dirt on the reflecting surfaces of the luminaire. A maintenance factor (MF) must be applied in the lighting calculations to

compensate for the gradual losses of illumination on the lighted area.

The following maintenance factors have been widely used in industry when manufacturer's information is not available:

Enclosed flood lamps, 0.76

Open flood lamps, 0.65

LIGHT INTENSITY CALCULATIONS

There are a number of ways by which to determine luminaire requirements. Since most methods would require an engineering background, we will only discuss the basic area lighting design considerations that you, as a Construction Electrician, can perform in the field if engineering assistance is not available. To better understand how the calculations are performed, solve this sample problem:

Determine the average, initial light level in a 160-foot x 160-foot material storage yard using two NEMA 6 x 5 HLX 1,000-watt floodlights.

Solution:

1. Apply the 2X-4X rule (fig. 6-28) to determine spacing and mounting height. A 40-foot mounting height provides $MH \times 2$ or an 80-foot aiming distance.
2. The formula used to calculate the average, initial light level (fc) is as follows:

$$fc = \frac{(N)(LL)(CU)}{AREA}$$

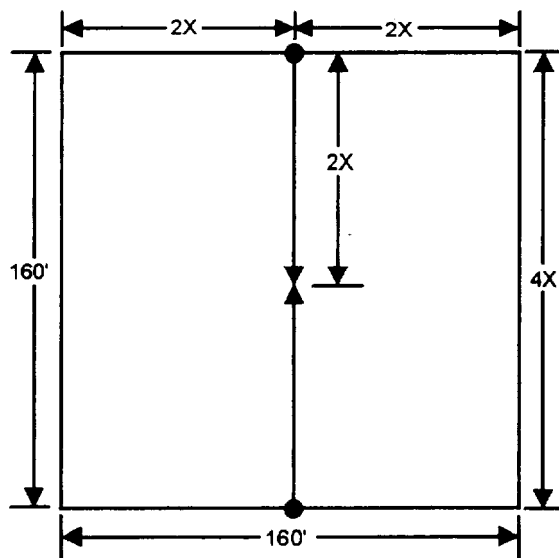

CEIF0628

Figure 6-28.—Material yard sample problem.

Where:

N = number of floodlights

LL = initial lamp lumens

CU = utilization of the floodlights

From the utilization data (fig. 6-27), you can find that the utilization for the HLX luminaire aimed at two mounting heights across an area 160 feet or four mounting heights wide is 38 percent. The initial lumens for the 1,000 watt lamp are 140,000 lumens, obtained from the manufacturer's literature. Substituting in the formula,

$$fc = \frac{(2)(140,000)(0.38)}{(160)(160)} = 4.2 \text{ fc}$$

The maintained light level is obtained by multiplying the initial light level by the maintenance factor.

$$fc = (4.2)(0.75) = 3.15 \text{ fc}$$

Using the isofootcandle diagram, we obtain point by point footcandle values: for example, the center of the area occurs just inside isofootcandle line E. From the initial footcandle table, the 1,000-watt HLX at 40 feet produces 3.1 footcandles at line E and 7.8 at line F. Since the point is approximately one fourth of the distance between the two isofootcandle lines, the value will be about 4.0 footcandles. With the two floodlights contributing, the value in the center will be 8.0 footcandles. Note that the corners of the area will have very little light. That is why two or more floodlights are recommended at perimeter locations.

Another design method that will yield sufficient accuracy is the quick selector design method. The general layout considerations shown in figure 6-28 should be followed. The watts per square foot obtained from the graph in figure 6-29 produce an average lighting level accurate to within 20 percent of desired value. That is close enough, since the difference between the luminaire requirement obtained from the graph and the number that will actually be needed to satisfy the physical requirements of the job involve adjustments greater than 20 percent. It is not unusual, for instance, to need two poles instead of one or to require three luminaries per pole instead of two. This calculation method should not be used for sports lighting or where the poles are set back from the area to be lighted.

Before determining the number of luminaries, you should work out the size of the area to be lighted. Also,

you should determine the maintained illumination level. The following rules of thumb provide some guidelines to help in these decisions.

1. From figure 6-21, you find that the minimum average footcandles recommended for industrial yard/material handling is 5.

2. Read up the left side of the graph in figure 6-29 until you come to 5. Follow this line across until you intersect the dark diagonal line representing Lucalox[®].

3. By reading straight down from this intersection to the value at the bottom of the chart, you find 0.095 lamp watts/square foot of the area is required to light the yard to 5 footcandles.

4. Area to be lighted is (160)(160) = 25,600 square feet.

5. Multiply 25,600 by 0.095 = 2,432 lamp watts.

2,432 is more than two 1,000-watt Lucalox[®] lamps

2,432 is approximately equal to six 400-watt Lucalox[®] lamps

2,432 is approximately equal to ten 250-watt Lucalox[®] lamps

6. By using the general layout considerations, you will find that the most economical floodlight installation will use the 400-watt Lucalox[®] lamps, mounted on 40-foot poles, as shown below.

$$2X + 2X = 4X = 160 \text{ feet}$$

$$X = \frac{160 \text{ feet}}{4} = 40 \text{ feet MH.}$$

SECURITY LIGHTING

Requirements for security lighting at activities will depend upon the situation and the area to be protected. Each situation requires careful study to provide the best visibility that is practical for guard duties, such as identifying personnel and vehicles, preventing illegal entry, detecting intruders, and investigating unusual or suspicious circumstances.

The type of security lighting may be either the continuous or the standby type. The continuous type, as the name implies, is on all the time during the hours of darkness. The standby type is activated either manually or automatically when suspicious activity is detected.

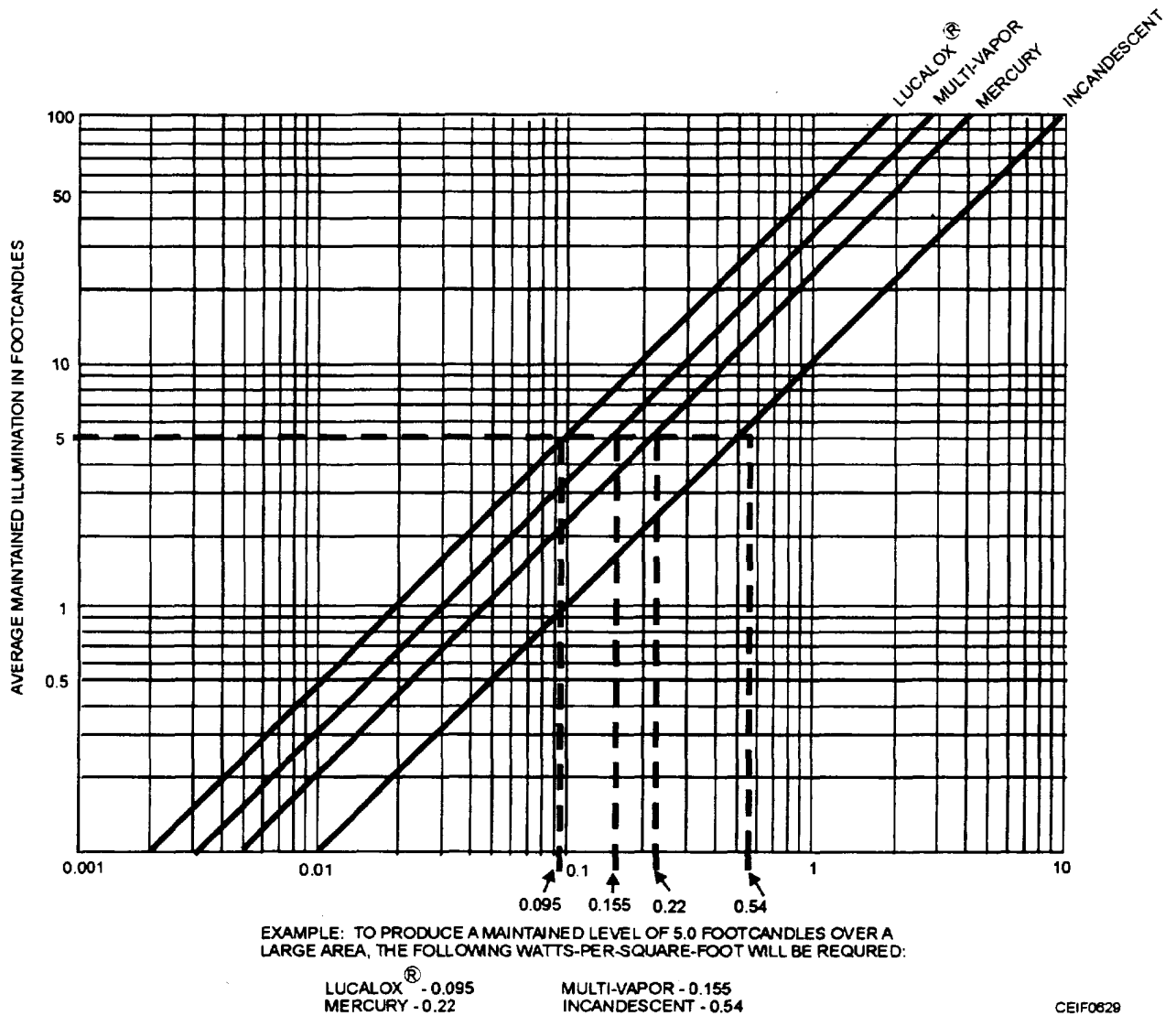

Figure 6-29.—Lamp watts per square foot chart.

SECURITY AREA CLASSIFICATION

The installation of security lighting is set forth in *United States Navy Physical Security Manual*, OPNAVINST 5530.14. It provides specifications on searchlights and minimum footcandle requirements under given situations. The illumination of boundaries, entrances, structures, and areas must be according to the security manual.

LIGHTING CONTROL

Each security lighting system is designed to meet a particular need of the activity. The design is such that it provides the security required at maximum economy.

Multiple circuits may be used to advantage here. The circuits are so arranged that the failure of any one lamp will not darken a long section of the area. The

protective lighting system should be independent of other lighting systems and protected from interruption in case of fire.

The switches and controls of the system should be locked and/or guarded at all times. The most effective means is to have them located in a key guard station or central station similar to the system used in intrusion alarm central station installations.

ALTERNATE POWER SOURCES

In general, any security area provided with protective lighting should have an emergency power source located within that security area. The emergency power source should be adequate to sustain all security requirements and other essential service required within the security area. Provisions should be made to ensure the immediate availability of the

emergency power in the event of power failure. Security force personnel should be capable of operating the power unit. If technical knowledge prevents this, plans must provide for responsible personnel to respond immediately in times of emergency. In addition, battery-powered lights and essential communications should be available at all times at key locations within the secure area.

AIRFIELD LIGHTING

As a Construction Electrician second class petty officer, you may be responsible for the installation of expeditionary airfield lighting and any repairs or maintenance required to the installation as well as to permanent advanced base launch and landing facilities.

Since the Seabees existence is based on being used in contingency operation, you should know the equipment and components of such a contingency lighting system. The "Expedient Airfields Facility," 13610A, as taken from the Advanced Base Functional Component Facility Listings, provides such information. If the world situation should develop to a point where the Seabees are alerted and tactical air support is required, such a kit would accompany you to the forward area. For contingency operations, the types of airfields used may be any of the following:

1. Vertical takeoff and landing (VTOL) airfields
2. Vertical short takeoff and landing (VSTOL) airfields (600 and 1,800 feet)
3. Expeditionary airfield (EAF)
4. Strategic expeditionary landing field (SELF)

The scope of this chapter is not to provide details on the electrical systems used at each of the above-mentioned airfields but rather to acquaint you with the components of the systems and their functions for both expeditionary and permanent airfields.

Normally, the VTOL airfield is an installation made of aluminum matting and is used as a forward landing field by either helicopters or Harrier type of aircraft; whereas, the VSTOL airfield, also an aluminum matted installation, is usually used as a forward operational facility. The EAF is used by high-performance aircraft and is also used as a forward air facility. The SELF is similar to the EAF, but with a longer runway.

AIRFIELD LIGHTING SYSTEMS

Airfield lighting systems are designed to aid pilots during launch, recovery, and taxi operations. The reasons for these systems date back to the days of smudge pots and the burning of brush piles to help guide pilots into safe landings. Through the years, the methods of lighting airfields have become much more sophisticated. The lighting systems today have the light properly distributed, have light controls, and also have the ability to define certain areas by means of different colored lenses and filters inside of the lighting fixtures.

The patterns and colors of the light, as well as the markings, at each airfield are uniform to enable the pilots to interpret what is seen and then to react almost automatically. To ensure that airfield lighting standards are met, the Federal Aviation Administration (FAA) has been tasked with developing the standards and with the policing authority to ensure compliance within the United States. In addition, FAA standards are used in airfields constructed by the military overseas.

The design of airfield lighting systems must provide for locating an obstruction warning system, runway and approach markings, and taxiway and parking facility markings.

AIRFIELD LAYOUT

The VTOL forward operating site is a portable airfield of minimum size designed for operations dependent upon logistic or tactical support by helicopters and other vertical takeoff or landing aircraft. The field consists of a surface pad 72 feet square, as shown in figure 6-30, view A, without lighting, communications, or recovery systems.

A VSTOL facility is a portable airfield capable of providing support to VSTOL fixed-wing aircraft as well as helicopters. The field consists of a surfaced runway 900 feet long and 72 feet wide and turnoff, parking, and maintenance areas. The nature of the aircraft to be serviced precludes the necessity for arresting gear; however, a field lighting system and a communications system are supplied to provide suitable aircraft recovery capability. A VSTOL facility can readily be converted to a VSTOL air base.

A VSTOL air base also is a portable airfield capable of providing support for VSTOL fixed-wing aircraft as well as helicopters. The field consists of a surfaced runway 1,800 feet long and 72 feet wide and turnoff, maintenance, and parking areas to

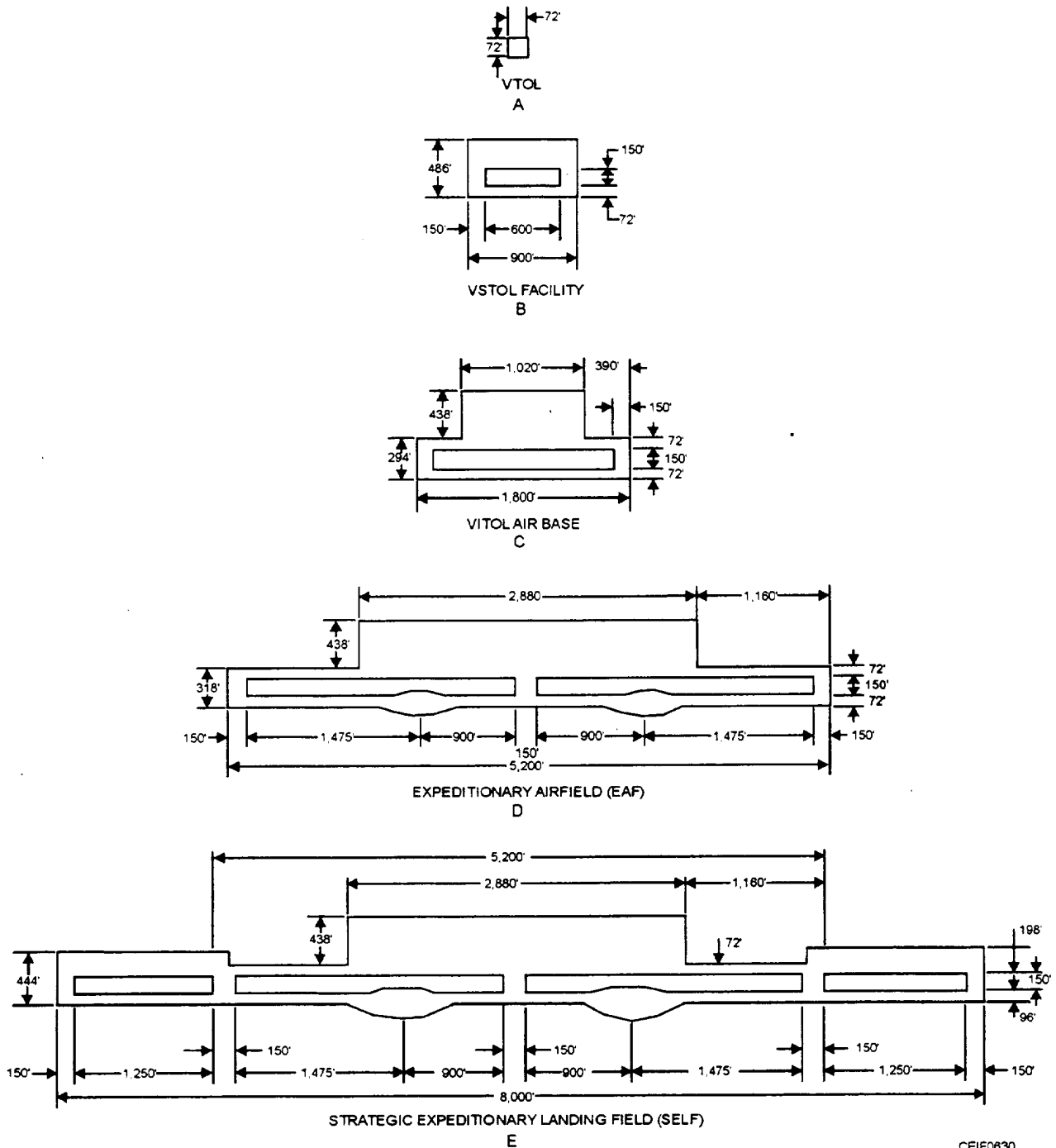

Figure 6-30.—Field arrangement direct installation.

accommodate up to 12 aircraft. From the VSTOL air base assets, plans are provided from which three VSTOL FACILITIES can be constructed. The VSTOL air base can support at least one squadron of light VSTOL attack aircraft and a number of helicopters. The nature of the aircraft serviced by the VSTOL air base precludes the necessity for arresting gear; however, a field lighting system, a Fresnel® lens optical landing system (FLOLS), and a

communications system are incorporated to provide suitable aircraft support. A VSTOL air base readily may be converted to an expeditionary airfield (EAF).

The EAF is a portable airfield that provides a surfaced runway 5,200 feet long and 96 feet wide, as shown in figure 6-30, view D, and parking and maintenance areas for up to six squadrons of light-to-medium fighter/attack aircraft, in addition to a complement of reconnaissance aircraft and

helicopters. The field includes two M-21 aircraft recovery systems, two FLOLS, and field lighting and communications systems. An EAF may readily be converted to a strategic expeditionary landing field (SELF).

The SELF is a portable airfield that provides a surfaced runway 8,000 feet long and 96 feet wide, as shown in figure 6-30, view E. The SELF is a pre-positioned war reserve (PWR) setup. The airfield provides turnoff, maintenance, and parking areas to accommodate up to six squadrons of light-to-medium fighter/attack aircraft, a detachment of tanker aircraft, and various transient logistic support aircraft. The SELF configuration includes two M-21 aircraft recovery systems as well as two FLOLS and field lighting and communications systems.

AIRFIELD LIGHTING VAULT

The beginning of the airfield lighting system is the airfield lighting vault. The primary power feeder enters the vault and supplies power to all of the major components. These components, in turn, control and operate the airfield lights. The vault houses the high-voltage power cables, the current regulators, the relay cabinets, and the control panels.

The control cables are installed between the vault and the control tower or other control points. The high-voltage cables are connected to the regulators and run out to the lights. The lighting control panels are used to give local/remote control of the system. The same type of remote control panel that is in the vault should also be installed in the control tower.

The airfield lighting vault should be about 3,000 feet from the runway. This distance ensures that no interference will occur with the operation of the airfield, and still, it is not so far away that voltage drops might cause a problem. The lengths of the control circuits between the control tower and the vault are limited by operational characteristics; for example, size of field, obstructions, and so forth. The minimum distance is 350 feet; that is to prevent the equipment in the vault from causing radio interference. If the control cable leads terminate into actuating coils of relays in the pilot relay cabinet, the maximum distance is 7,350 feet.

Safety

The airfield lighting vault should have certain items of safety equipment affixed to a board. This

board should be an open display and easily accessible. It should be a minimum of 1/2 inch thick and 4 by 4 feet in width and length. The color should be dark green with white letters and borders.

On this board, some of the safety items you should have are as follows:

1. Operating instructions for the equipment in the vault
2. Resuscitation instructions
3. A phone and a list of emergency phone numbers
4. A first-aid kit
5. A switch stick with a minimum length of 5 feet and a 300-pound pull ability
6. A hemp rope, 1/2 inch thick, with a minimum length of 15 feet
7. Insulated fuse pullers (for secondary cartridge fuses)
8. A nonmetallic-encased flashlight marked with luminescent tape to aid in its location in the dark
9. A shorting stick
10. Rubber gloves

For the safety of personnel, the airfield lighting vault must be grounded. That may be accomplished by using two 1/2-inch-diameter, 8-foot-long, copper-plated electrodes, driven into the ground about 8 feet apart and connected in a loop with the vault or ground cable part of the ground grid. This typical connection is shown in figure 6-31.

Power Supply

In many cases, the power supply will not be all high or low voltage. In fact, in many expeditionary airfields, the system may be a combination of high and low voltage. However, if you are assigned to a naval air station, chances are that you may be required to maintain high-voltage airfield lighting systems. Basically, the systems are identical, but because of safety requirements, the high-voltage systems will have a few variables. As an example, take the isolation transformer (IT) in the high-voltage system; it serves to step the voltage down, but its primary purpose is to prevent an opening in the primary series loop when a lamp failure occurs. In a low-voltage system, the transformer is usually a 2: 1 or 1: 1 ratio unit that serves to maintain a closed loop—the same function as the one in the high-voltage system. Even though we will

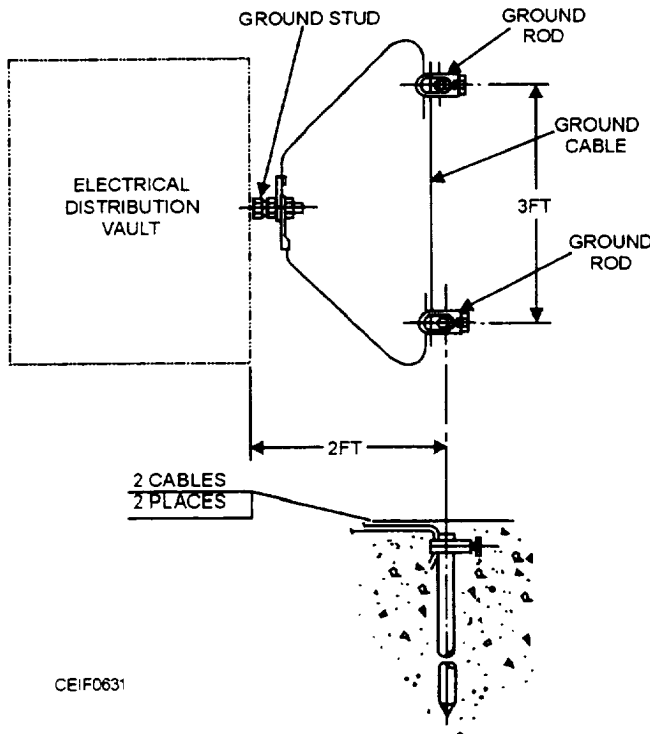

Figure 6-31.—Vault grounding arrangement.

be talking primarily about high-voltage systems most of the time, the functions of the components will apply to either system.

In the 2,400/4,160-volt system, the four-wire wye primary source is usually from the base electrical system by means of either an overhead or an underground line. Inside the vault, the lines are connected to a suitable switch, then to a bus system consisting of heavy metal bars that are supported on insulators. This bus system may be mounted on either the wall or the ceiling.

The bus is divided into a high-voltage (2,400-volt) bus and a low-voltage (120/240-volt) bus for service as follows: the 2,400-volt bus supplies all of the 2,400-volt regulators and one or more distribution type of transformers. The distribution transformers supply 240 volts to the low-voltage bus that is connected to the regulators operating from this lower voltage as well as for light and power inside the lighting vault.

Where an emergency power supply is available for airfield lighting, a changeover switch makes the primary connection to the bus. This changeover switch in its normal position connects the bus to the base power source. Changing the switch to the emergency operation position connects the bus to the emergency

power and, at the same time, disconnects the base power source.

Emergency power can be supplied by a completely automatic engine-driven generator; for example, failure of the base power causes the engine to start. In a matter of seconds, the changeover switch automatically shifts to the emergency position, connecting the generator to the airfield lighting bus.

At many advance bases, this automatic feature may not exist. You would have to hook up the proper sized generator manually. The generator should have a kilowatt (kW) rating capable of handling the airfield lighting systems, runway edge lights, threshold lights, approach lights, distance markers, optical launching system (OLS), and other circuits that may be used. The generator is three phase; its voltage output varies from 120/240 volts delta or 120/208 volts wye to 2,400/4,160 volts, and it has to be capable of being operated at frequencies of 50 or 60 hertz (Hz).

Constant-Current Regulator

Runway lighting systems are supplied from series circuits served by constant-current regulators (CCRs). Each lighting circuit on the airfield has a separate regulator. The CCRs maintain the output current throughout its rated output value, depending on the load. Some of the regulators are equipped with brightness controls. These brightness controls adjust the brightness of the lamps in the lighting system to compensate for visibility conditions.

The CCR uses solid-state devices to maintain a constant-current level in its respective lighting system. The regulators are silicon-controlled rectifiers (SCRs) in a feedback circuit to obtain a constant-current output instead of resonant circuits, moving transformer elements, or saturable reactors. The SCRs are controlled to vary the part of a cycle during which the current is permitted to flow into the load circuit. In the load circuit, the current is maintained constant at any value preset with the brightness control by means of a feedback circuit as the load resistance is varied from maximum to zero. The block diagram (fig. 6-32) shows the elements constituting the regulator. Load current is measured by the current transformer and the Hall unit, or multiplier unit, that has an output voltage proportional to the square of the load current. The Hall unit, or multiplier, output is filtered and fed into the input of an amplifier and compared with an input from a brightness control potentiometer. The output voltage is a function of the difference between the two inputs.

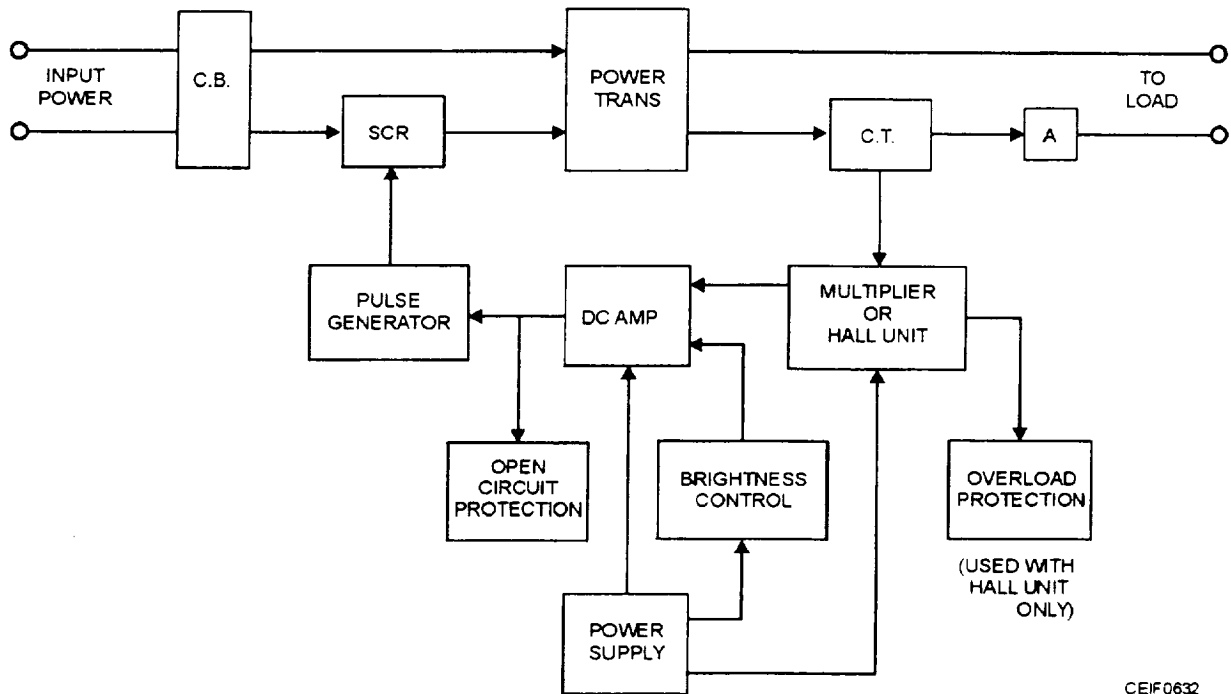

Figure 6-32.—Block diagram of constant-current regulator.

The output voltage is applied to the input of the gate pulse generator that determines the condition angle of the SCRs and changes it to bring the system to equilibrium. Transient overload protection is provided for the semiconductor element of the Hall unit. Open-circuit protection is provided when no current is drawn by the load and the brightness potentiometer output voltage is any value other than zero. Under these conditions, the SCRs will be prevented from conducting, and the output voltage to the load will be zero.

Remote Control

The airfield lighting systems may be operated completely by the remote control panel assembly. The only operation required at the electrical distribution vault is to ensure that all circuit breakers are engaged,

the regulators are set for remote operation, and the load switches are in the ON position. The electrician must ensure that the unit is installed properly and that the different levels of light intensity desired can be achieved. Figure 6-33 is a typical view of a remote control unit that you may encounter in the installation of a contingency airfield lighting system.

The unit uses 120 volts as the control voltage with low-burden pilot relays to compensate for the voltage drop caused by the long distances usually found between the control tower and the vault. In this type of control system, the switches on the control panel actuate low-burden relays; these, in turn, actuate the power switches, contactors, and the relays controlling the regulators that supply the airfield lighting circuits.

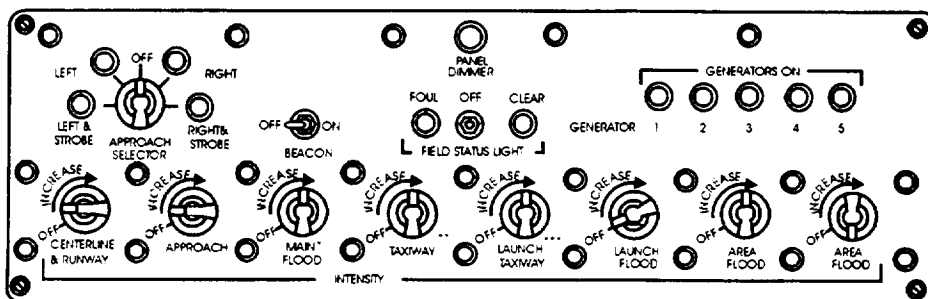

- * WILL BE RE-IDENTIFIED AS TAXWAY ON SELF.
- ** WILL BE BLANKED OUT ON SELF
- *** WILL BE RE-IDENTIFIED AS RUNWAY FLOOD ON ALL AIR FIELDS.

CBF0633

Figure 6-33.—Typical remote control panel operating controls.

Both the tower and vault control panels are wired into a double-throw “transfer-relay cabinet” located in the vault. That is shown in figure 6-34 with a single line representing the control cable. The transfer relay can connect either control panel to the pilot-relay cabinet. It can switch the system control from the tower to the vault or from the vault to the tower. The transfer relay has an eight-pole, double-throw, transfer-relay assembly unit. This unit is actuated by a toggleswitch.

The low-burden pilot relay is designed to operate at a wide range of voltages lower than the designed 120-volt ac rating. The pilot relay can be actuated at voltages from 50 to 90 volts ac.

The standard control cable is a No. 7 conductor, 600-volt, insulated, polychloroprene-sheathed cable. One conductor (black) is a No. 12 American Wire Gauge (AWG), and the remaining conductors are No. 16 AWG. The No. 12 conductor is the hot lead, and the No. 16, the “switch legs.”

LIGHTING CIRCUITS

Several different lighting circuits are used on airfields: runway edge lighting circuits, taxiway lighting circuits, approach lighting circuits, obstruction lighting circuits, beacon lighting circuits, and the

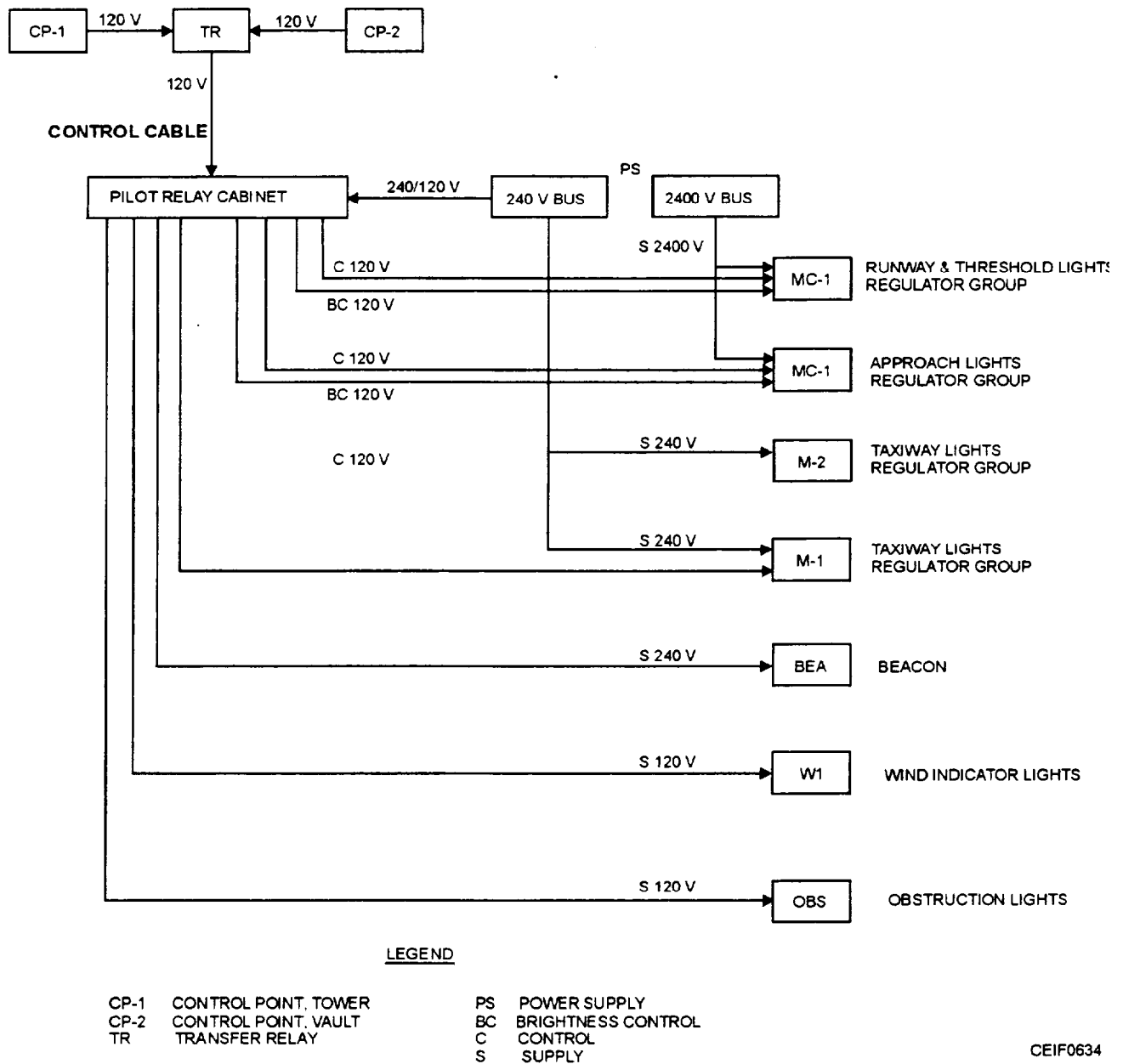

CEIF0634

Figure 6-34.—Airfield lighting control system

and the condenser discharge circuits. Each of these circuits will be covered separately.

Runway Edge Lights

Runway edge lighting is designed to show the width and length of the usable landing area; there are two rows of lights—one row on each side—that run the length of the runway. The light they give off is aviation white (clear). The edge lights are installed not more than 10 feet from the edge of the full-strength runway paving. Both lines of lights will be the same distance from the runway center line. It is best if the lines of lights are located as close to the runway as the base mounting for the lights allows. The lights are equally spaced along the runway at distances not to exceed 200 feet. (See fig. 6-35.)

The runway lighting controls are set up so that the lights on intersecting runways cannot be on at the same time. Also, the controls must turn all the light systems of one runway on at the same time. The runway edge lights are controlled so all the lights are the same brightness. In a high-intensity system, threshold lights are one step higher than the runway edge lights except when the runway edge lights are at full brightness. At this time, both the runway edge lights and the threshold lights are at full brightness. In a medium-intensity runway lighting system, all lights (runway edge lights and threshold lights) are the same brightness.

In some instances, it is a good practice to use runway edge light fixtures and lamps for the threshold lights, so that the difference is noticeable when the threshold lighting configuration has to be stepped up one brightness higher than the runway edge lights. To determine the number of circuits required for runway edge lights, you need to determine the length of the runway. You determine the number of lights on one circuit by considering not only the number of lights connected to the circuit but also the voltage loss for the circuit cables and the feeder cables from the vault to the runway. If this distance is long, you may need to adjust the number of lights in the circuit.

Do not load the regulator less than one half of its rated kilowatt (kW) output. If more than one regulator is required, each regulator should be equally loaded.

Each light circuit will be fed by a series loop. The current leaves one terminal of the CCR, goes through the circuit to each light unit, and returns to the other terminal of the regulator.

Taxiway Lights

Taxiway lights are used to show the pilot the width and direction of the “taxiing route.” The lights are aviation blue in color. They are basically the same as runway lighting circuits.

Approach Lights

Runway approach light systems are used on high-intensity-equipped runways. The system starts at the threshold and extends outward for 3,000 feet. When the full length of the land cannot be used, the greatest length possible is used. Condenser discharge (strobe) lights that put out a high-intensity, bluish white light start at the 3,000-foot mark and flash in sequence toward the threshold. The system is used to help the pilots land under low-visibility conditions. The condenser discharge lights are discussed in more detail later in this chapter.

The lights of the approach system are located on an imaginary line that extends from the runway center line. Each light bar is centered on this imaginary line and spaced the same distance apart for the entire 3,000 feet.

The supply and control circuits of the approach lighting systems are installed underground and are usually in conduit; however, in some cases, the last 2,000 feet of the approach lights can be above ground. In some cases, the supply cable from the series circuit can be direct burial.

Aboveground circuits may be used for approach lighting when the cables do not present a hazard to vehicular traffic or are not accessible to unauthorized personnel and animals. The cable must be installed, normally, a minimum of 22 feet above ground. Where the area is completely closed off (fenced): a lower ground clearance is acceptable. Control circuits may use a small-size conductor when it is supported by a messenger cable. **DO NOT USE ALUMINUM CONDUCTORS.** Use standard overhead construction practices for series circuits. Use lightning arresters when the cables go from underground to overhead. Connect the ends of the circuits in the same way as underground cables.

Besides the basic runway light configuration, there are other airfield lighting aids to help the pilot in landing and takeoff operations. Four such aids for landing and taking off are the visual approach slope indicators (VASI), the Fresnel[®] lens optical loading system (FLOLS), the runway distance markers, and the threshold lights.

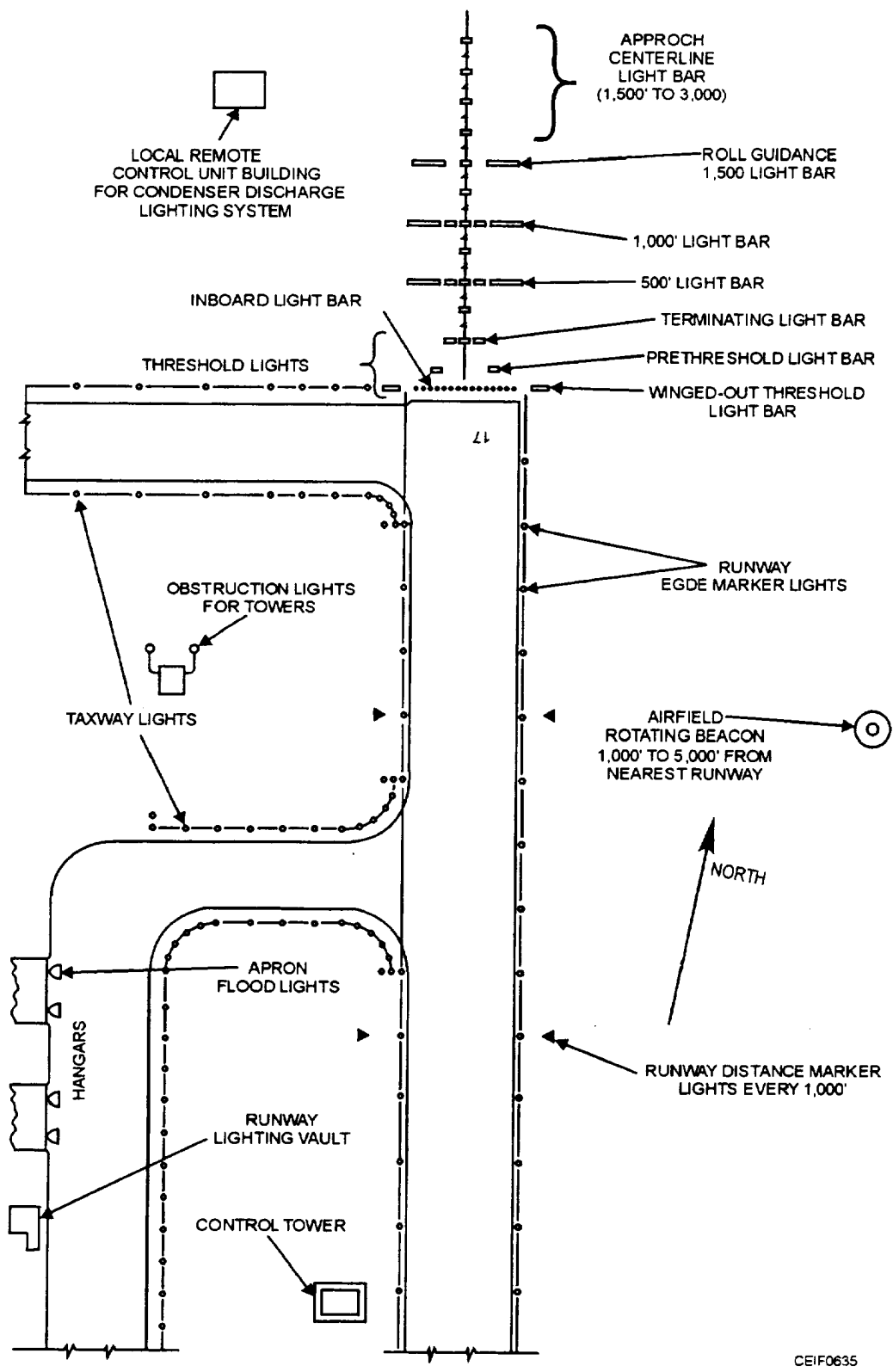

Figure 6-35.—Typical airfield lighting layout.

CEIF0635

VISUAL APPROACH SLOPE INDICATORS (VASI)—The VASI system provides the pilot with visual approach slope angle information while on final approach. The VASI system is helpful during daylight or night operations. There are three standard VASI system configurations: VASI-4, VASI-12, and VASI-16. We will discuss the VASI-12 system as it will appear on most Navy airfields.

The VASI system consists of twelve light boxes with three lights in each box. There is one complete system for each end of the runway. There are two pairs of bars—one pair of bars on each side of the runway. Each wing bar is composed of three light boxes (fig. 6-36). The set of bars nearest the threshold is called the downwind bars, and the other pair, the upwind bars. Each light box projects a beam of light that is white (clear) in its upper part and red in its lower part. The lights are arranged so that the pilot of an airplane, during the approach, sees all of the wing bar lights as red when below the glide slope. When on the glide slope, the pilot sees the downwind bar lights as white and the upwind bar as red. When above the glide slope, the pilot sees all the wing bar lights as white.

FRESNEL® LENS OPTICAL LANDING SYSTEM (FLOLS).—Another system designed for continuous automatic operation is the FLOLS. (See

fig. 6-37.) It also provides optical landing assistance by indicating the correct glide slope angle to the pilot of an approaching aircraft. This system contains two groups of horizontal datum lights set perpendicular to the approach path; two vertical bars of wave-off lights; two double types of cut lights; and a source light indicator assembly, consisting of five vertical cell assemblies. Each cell assembly contains source lights, a Fresnel® lens, and a lenticular lens. The arrangement of these lenses gives the pilot the glide slope. The unit should be set up on the left side of the runway, from the pilot's perspective, about 10 feet from the edge of the pavement and 750 feet from the runway threshold.

Power for the system is provided by an installed field lighting supply or by an auxiliary, power unit capable of 20 kilowatt (kW), 60 hertz (Hz), three-phase, 120 volts phase to neutral.

RUNWAY DISTANCE MARKER.—With the use of high-speed aircraft, the runway distance marker system is needed to tell the pilots how much runway is left to take off or to land. The distance information, in thousands of feet, is given by numbers on the side of the marker. The numbers are on two sides of the signs, so that the distance left can be shown for both directions. There is one row of signs on each side of the runway. Each row is the same distance from the runway center

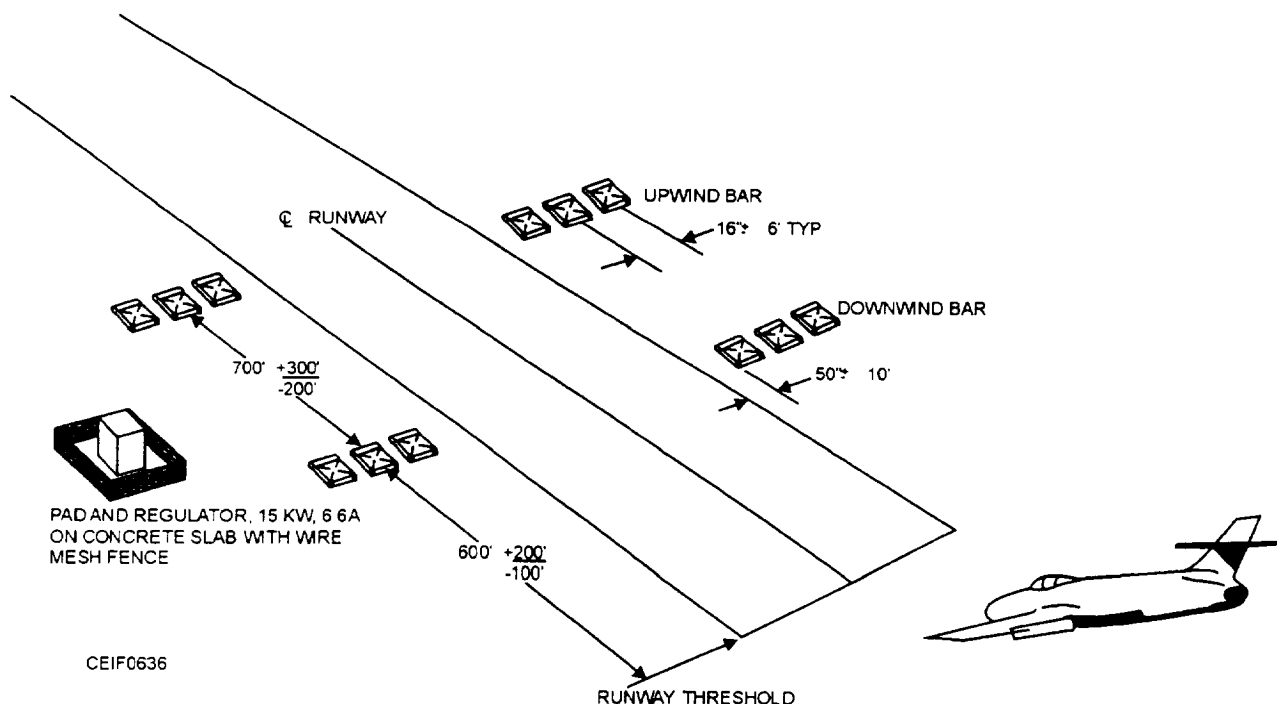
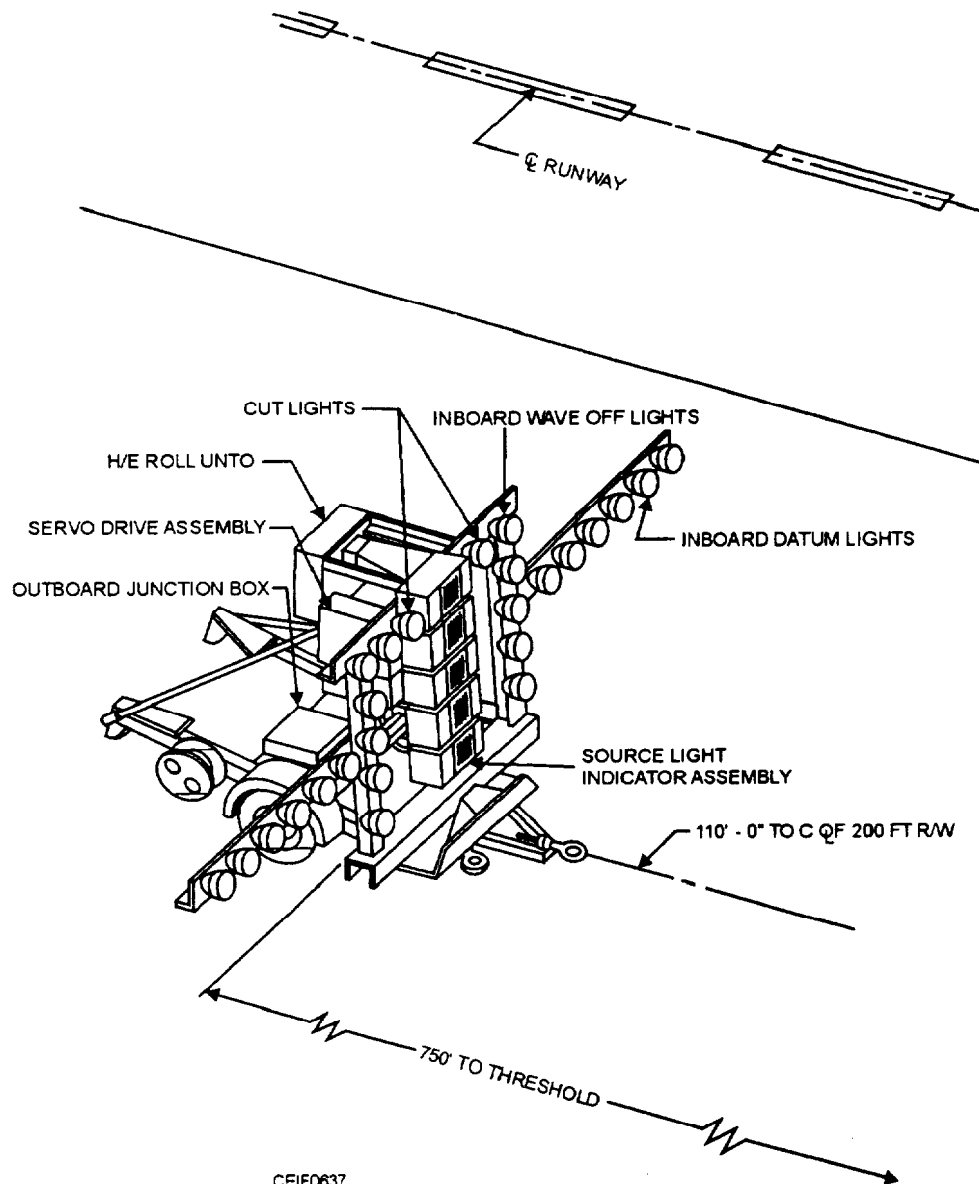

Figure 6-36.—Visual approach slope indicators (VASI).



CEIF0637

Figure 6-37.—Fresnel® lens optical landing system (FLOLS).

line. They are spaced 1,000 feet apart. The signs have painted numbers that are lit so they can be seen at night and during periods of restricted visibility.

The power supply for serving the runway distance markers should be from a separate series circuit. Do not have the markers supplied from circuits feeding either the runway, threshold, or the approach lighting circuits, since these circuits are operated at various brightness steps, and the signs are operated at their full brightness at all times. Also, do not connect them to taxiway circuits because of the intermittent operation requirements. The cable used for the runway distance marker circuit is a single conductor, No. 8 AWG, stranded, 5,000 volts.

THRESHOLD LIGHTS.—The threshold lights are a part of the approach light system. Four sets of light systems are used in the threshold light configuration. These lights are as follows: inboard threshold lights, winged-out threshold lights, prethreshold wing bars, and a terminating bar. These four sets of lights are installed on both ends of the runway and are used to mark the beginning of the runway.

Inboard Threshold Lights.—Inboard threshold lights are installed in the area at the end of the runway between the two runway edge light lines. This line of lights will be at a right angle to the runway center line. They arc as close to the full-strength paving as possible but not more than 10 feet from it. The lights

are spaced 10 feet apart. Their color is aviation green. (See fig. 6-35.)

Winged-Out Threshold Lights.—The winged-out threshold light bar is on the same light line as the inboard lights. These lights extend out from the end of each side of the inboard light bar. Each bar is 40 feet long and has nine lights spaced 5 feet apart. The first light location is at the intersection of the runway edge light line and the threshold light line. The color of these lights is also aviation green. (See fig. 6-35.)

Prethreshold Wing Bars.—A prethreshold wing bar is located on each side of the extended runway center line 100 feet out from the threshold. The innermost light of the bar is 75 feet from the center line. Each bar (14 feet long) has five aviation red lights spaced 3 1/2 feet apart. (See fig. 6-35.)

Terminating Bar.—The terminating bar is located in the overrun area. The light bar is at a right angle to the runway center line and 200 feet out from the runway threshold (100 feet out from the prethreshold lights). There are 11 aviation red lights in the bar. The bar is 50 feet long and is arranged so that one half of the bar is on each side of the center line. The lights are arranged in three groups: five lights spaced 3 1/2 feet apart on a 14-foot bar in the middle and, on each side, one 10-foot bar of three lights spaced 5 feet apart. (See fig. 6-35.)

Obstruction Lights

Obstruction lighting is a system of red lights used to show the height and width of natural or man-made objects that are hazardous to air flight. These lights are for the safety of aircraft in flight. The lights must be seen from all directions and are aviation red in color.

The obstruction lights are turned on during all hours of darkness and during periods of restricted visibility. They are placed on all objects with an overall height of more than 150 feet above ground or water within the airspace.

At least two lights (or one light fixture with two lamps) are located at the top of the obstruction. When the top of an obstruction is more than 150 feet above the level of the surrounding ground, an intermediate light, or lights, is provided for each 150 feet. These lights are equally spaced from the top to the bottom.

Where obstructions cover an extensive horizontal plane, the top lights will be put on the point or edge of the obstruction highest in relation to the obstruction-marking surface. The lights should not be spaced more

than 150 feet apart. This spacing indicates the general extent of the obstruction. Double lights are used at the horizontal limits of the obstruction, and single lights are used for intermediate lights. If two or more edges are of the same height, the edge nearest the airfield is lit.

On overhead wires, obstruction lights are placed at intervals not exceeding 150 feet and at a level not below that of the highest wire at each light location.

Obstruction lighting systems are served by, either a series or a multiple circuit. The type of circuit used depends on the location of the obstruction and the type of lighting equipment installed. The six most common types of circuits that may be used for the obstruction lights are as follows:

1. Low-voltage multiple service from the vault when the length of the circuit is less than 800 feet
2. Series circuit when the load is less than 4 kilowatts (kW) from a taxiway type of regulator in the vault
3. Twenty-four hundred-volt service from the vault to a distribution transformer to serve a multiple circuit
4. Twenty-four hundred-volt service from the vault to a CCR that serves a series circuit
5. Control circuit from the vault that operates any of the previously listed circuits by means of a relay
6. Time clock or a photocell with a series or multiple circuit for the lights

Obstruction lights on objects that are more than 150 feet above ground or water must be on all the time or controlled by a photocell.

Beacon Lights

The landing facility location is provided by the aeronautical beacon. The beacon is a high candlepower flashing light visible throughout 360 degrees. It provides the pilot a visual signal to locate and identify airfields during night operations or during periods of restricted visibility, day or night.

There are three functional types of beacons that we will discuss: the airport beacon; the identification, or code beacon; and the hazard, or obstruction beacon.

The airport beacon is normally located within 5,000 feet of the airfield. The rotatable unit will display

alternate double-peaked white flashes and a single green flash to identify the airfield as a military facility. The size of the unit is about 24 inches; a rigid drum duplex type with a clear double-flasher spread-light lens on one end and a plain green lens on the other. There is an automatic built-in lamp change in case of lamp burnout. An illustration of a typical airport beacon is shown in figure 6-38. Beacon lights may be manually controlled from the tower or from the lighting vault. If the facility is not operated on a 24-hour basis, an automatic control is possible with a photoelectric control that turns the unit ON or OFF automatically.

The identification beacon, or code beacon, identifies an airfield where the airport beacon is more than 5,000 feet away from the airfield or where two or more airfields are close enough to use the same airport beacon. This nonrotatable unit can be seen from all directions and is equipped with a flasher switch operating at 40 flashes per minute with a range adjustment. The beacon has white lenses with green filters and is manually controlled from the tower but may be controlled automatically.

The third beacon, the hazard, or obstruction beacon, furnishes visual identification of natural features or structures that are 150 feet above airfield elevation for on-station or off-station hazards; that is,

tanks, towers, stacks, and so forth. The beacon uses white lenses with red filters and is manually controlled from the tower. When automatic controls are desirable, a photoelectric control system may be used. Since the beacon does not rotate, a flashing system is used—flashing 26 times per minute. The beacon lamps and motor require 120 volts for operation. Most of the time, this unit is fed by a 120/240-volt or 120/208-volt, three-wire service. You can use a 120-volt, two-wire service, but it is not recommended. When the lighting vault is less than 800 feet away from the beacon, a low-voltage service can be used. When the vault is more than 800 feet away, high voltage (2,400 volts) from the lighting vault is used to supply a distribution transformer at the base of the beacon. You also can run a control wire from the vault to the beacon to operate a relay that, in turn, switches on the power from a local source near the beacon. The last method works best when the beacon is at a remote location from the airfield.

Because of the extreme hazard to life, an alternate low-voltage source near the beacon is usually required.

TYPES OF FIXTURES AND LAMPS

To meet different system requirements, you must have different intensities of lighting. Along with these systems, you need different kinds of fixtures to meet

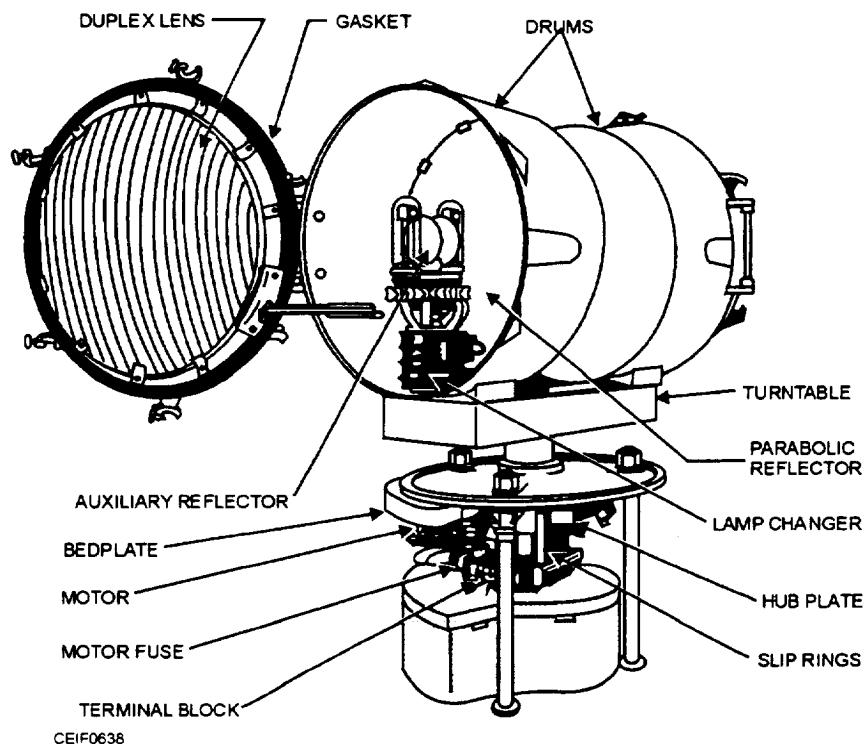

Figure 6-38.—Beacon with one door open and base pan dropped.

the needs of designated locations. In each fixture, a certain type of lamp must be used to give off the right kind of light. A runway light fixture, in a series loop system, requires an isolation transformer (IT). These transformers must be matched to each lamp according to amperage and watts. Figure 6-39 provides you with a pictorial view of the lighting fixtures used in contingency airfield operation; table 6-3 provides the Naval Air System Command part number of each fixture plus the number of fixtures required per given type of field installation.

Several different types of lights are used. The exact type used depends on the system. Not only are there different fixtures for different widths of runways, but there are different intensities. In most cases, high-intensity lighting systems are used for high-speed air-

craft. Also, high-intensity lighting systems are required during low-visibility conditions.

CONDENSER DISCHARGE LIGHTING SYSTEM

The condenser discharge lights are added to make the approach system complete. Because the lamps flash on and off to give a stroboscopic effect, the term **strobe** is used for these lights. From here on out, the term strobe will be used when referring to condenser discharge lights.

The transformer and the master sequence timer cabinet are located in a small vault or pad near the center of the approach system. The vault or pad should be secured so neither animals nor unauthorized personnel can enter..

Table 6-3.—Airfield Lighting Equipment Required.

Component	NAEC Part Number	Quantity Per Field			
		VTOL 900'	VSTOL 1,800'	EMF 5,200'	SEL F 8,000'
Approach Light Assembly	505954-1	10	20	20	20
Center-line Light Assembly	613593-1	17	34	86	51
Circling Guidance Light Assembly	508233-1	-	8	16	16
Electrical Distribution Vault	615220-1	1	1	1	1
Floodlight Assembly 500W	615902	26	54	125	125
Floodlight Assembly 200W	615506-1 or 616324-1	12	12	24	12
Obstruction Light Assembly	505956-1	10	10	20	20
Regulator Constant Current 4kW	*616040-1	1	2	2	4
Regulator Constant Current 15kW	*614384-1	6	7	11	11
Remote Control Assembly	614896-1	1	1	1	1
Rotating Beacon Assembly	609990-1	-	1	1	1
Rotating Light Assembly	505954-2	4	4	-	-
Runway Light Assembly	615911-1	18	32	64	66
Status Light Assembly	409823-1	-	2	2	2
	409823-2	-	2	2	2
Strobe Light Assembly	506208-1	10	10	10	10
Strobe Power Supply	610361-1	10	10	10	10
Strobe Timer Assembly	610036-1	2	2	2	2
Taxiway Light Assembly	615910-1	37	92	122	228
Threshold Light Assembly	505954-3	8	8	-	-
	505954-4	-	-	4	4
Wind Cone Assembly	506054-1	1	2	2	2
**Lamp Holder	413021-1	10	-	-	-
**Adapter Bracket	423041-1	10	-	-	-
**Lamp	MS24348-5	10	-	-	-

*616040-1 and 614384 replaced with 618650 and 616360, respectively when supply is exhausted.

**Components of extended line-up light.

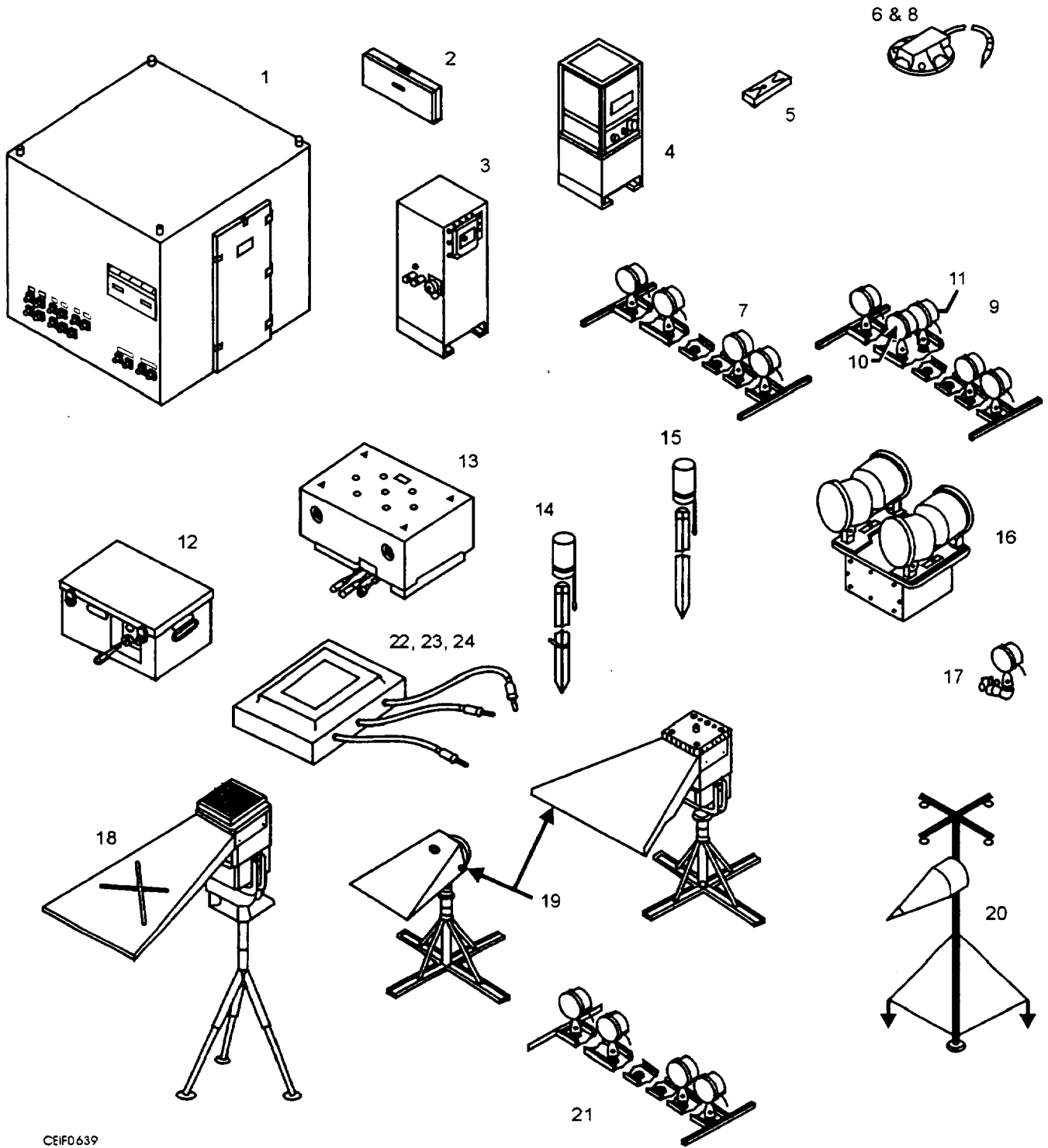

CEIF0639

- | | | |
|-------------------------------------|-----------------------------|---------------------------------------|
| 1. Electrical distribution vault | 9. Approach light | 17. Status light |
| 2. Remote control assembly | 10. Strobe light | 18. 500-W floodlight |
| 3. 4-kW constant current regulator | 11. Extended line-up light | 19. 200-W floodlight |
| 4. 15-kW constant current regulator | 12. Strobe timer | 20. Wind cone assembly |
| 5. Center-line sight | 13. Strobe power supply | 21. Rotation light |
| 6. Runway light | 14. Obstruction light | 22. Transformer - runway and approach |
| 7. Threshold light | 15. Circling guidance light | 23. Transformer - taxiway |
| 8. Taxiway light | 16. Rotating beacon light | 24. Transformer - work area |

Figure 6-39.—Airfield lighting components.

The major components of the condenser discharge lighting system are the elevated and semiflush strobe light units, the master sequence timer cabinet (containing the local/remote control unit, the monitor and control chassis, and the master sequence timer), and the tower control unit.

Strobe Light System

The strobe lights are installed on each center-line light bar starting 300 feet from the runway threshold and extending outward for the length of the system. The strobe light will be located on the center-line light bar, midway between the center light and the next light on either the left or right side. They can be placed in front of the light bar but not more than 10 feet. No matter where they are placed, they must be in the same position on each light bar throughout the entire approach system.

In the overrun area, the strobe lights are installed as flush lights. Starting with the 1,000-foot bar (decision bar) and going out, an elevated type of strobe light is used. An elevated approach light bar looks like the one shown in figure 6-40.

The strobe lights are controlled from the remote control panel. They can be turned on and off independently or so triggered that they come on when the approach light switch is in either the third, fourth, or fifth brightness position. The brightness of the strobe lights cannot be controlled.

The strobe lights put out a high beam of light that peaks at 30 million candlepower. **DO NOT LOOK INTO THE BEAM OF LIGHT WHEN YOU ARE NEAR ONE OF THE LAMPS OR YOUR EYES COULD BE DAMAGED.** The system we discuss here is one of several different types manufactured. The operation is the same no matter who manufactures them. Your knowledge of one will give you an understanding of the others.

Strobe lights are either flush mounted or elevated. The operation of the flush light is exactly the same as that of the elevated light unit. The main difference between the units is the way in which the components are arranged. We will be discussing the condenser discharge strobe light unit (figure 6-41); the numbered areas in parenthesis will refer to the numbered items in the figure.

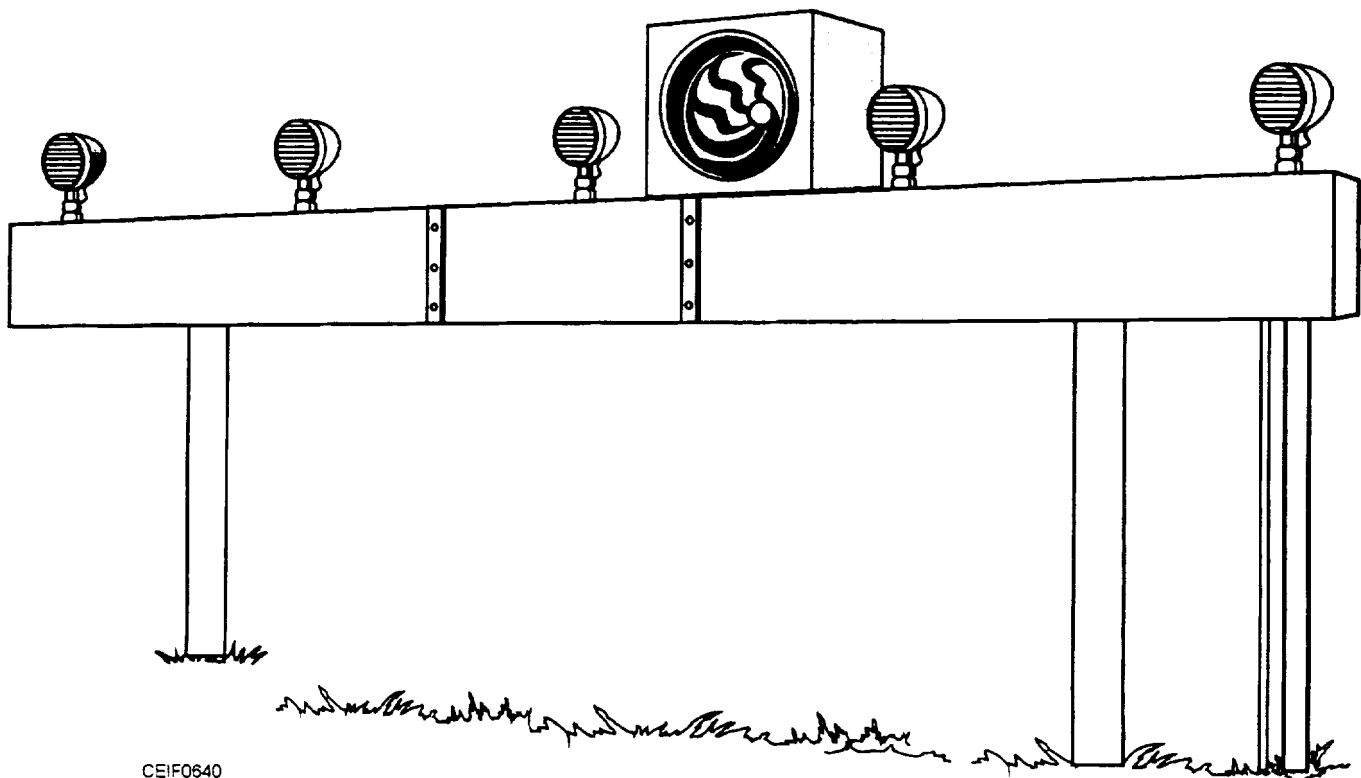

Figure 6-40.—Elevated approach light bar.

Each strobe light has four inputs from the rest of the system: (1) 240 volts ac, (2) ground, (3) 120 volts ac timing pulses at the rate of two per second, and (4) a dc voltage connection to the monitor system. These inputs are plugged into a cable through a four-pin connector (No. 10). The unit steps up the 240-volt ac input voltage to 1,460 volts ac with a transformer (No. 15) and passes this voltage through a full-wave rectifier circuit of vacuum tubes (No. 13). The resultant 2,000 volts dc is applied to the electrodes of a flashtube and across the flash capacitor (No. 4).

The xenon-filled flashtube will fire only when ionization is initiated by a trigger pulse of about 5,000 volts applied to its third electrode. This pulse is supplied by a trigger coil. At the same time that the flash capacitor is storing its charge, the trigger capacitor is also being charged by the primary of the trigger coil, which is an autotransformer, and cuts the bleeder resistors in series out of the circuit. When the 120-volt ac timing signal arrives, it is applied to the coil of the trigger relay (No. 9), thus closing the relay contacts, allowing the trigger capacitor to discharge through the primary of the trigger coil. That generates the necessary trigger pulse in the secondary of the trigger coil, the flashtube fires, and the flash capacitor discharges across the flashtube electrodes. The flash capacitor discharges down to the deionization potential of the flashtube, at which point the tube becomes a nonconductor. The light-producing arc ceases, and the charge cycle begins again.

The charge stored in the flash capacitor is a potential safety hazard. To make sure that the capacitor is discharged when the light unit is shut off, provide a discharge circuit by a series of bleeder relays. The bleeder relay (No. 5) closes this discharge circuit when the power to the transformer is turned off.

The current that charges the flash capacitor creates a pulse voltage in a surge resistor twice each second. A part of this voltage is applied to a silicon rectifier through a tap-off of the surge resistor. The rectified voltage is then filtered and applied to the monitor relay. The value of this voltage is sufficient to keep the monitor relay energized when the unit is flashing normally. When the unit stops operating because of a component failure in the unit, the absence of the pulse voltage at the surge resistor will allow the contacts of the monitor relay to close. This action completes a circuit from the monitor connection through a monitor resistor of 22 kilohms to ground. The monitor and control chassis react to the ground by warning the operator.

Master Sequence Timer Cabinet

The master sequence timer cabinet has all of the controls for the strobe light system except the tower control unit. The cabinet is supplied from a 240-volt, phase-to-ground circuit. Our discussion of how the system operates is keyed to the numbered items in figure 6-42.

LOCAL/REMOTE CONTROL UNIT.—The local/remote control unit (No. 1) gives you a way to turn the system on locally or give control to the tower. In the center of this unit is a control knob with three positions: REMOTE/OFF/LOCAL-ON. There are two red indicator lights above the control knob and two green lights below it. When the control knob is in the LOCAL-ON position, the system is turned on, and red lights will glow to indicate that the system is on LOCAL CONTROL. The green monitor lights should burn unless there is a fault in the system; in which case, they will go out. When the control knob is placed in the REMOTE position, the system can be turned on and off at the tower control unit. The red indicator lights will go out, but the monitor lights will continue to work as before. You should remember that the tower has no control except when the switch is in REMOTE.

MONITOR AND CONTROL CHASSIS.—The monitor and control chassis has several functions. They are as follows:

1. It de-energizes the monitor lights in both control units when a set number of lights stop working.
2. It has a step-down transformer to supply the voltages needed for control and indication.
3. It has a diode rectifier that supplies direct current for relay operation.
4. It has the fuses that protect the master sequence timer, the indicator circuits, and other components.

The main power transformer in the monitor and control chassis is energized all the time from a local 240-volt ac supply. The secondary voltage from this transformer energizes the indicator lamp transformer and the transformer of the dc circuit. The indicator lamp transformer supplies 12 volts ac to the indicator lights in the local/remote control unit. The transformer for the dc power will supply 95 volts ac to a bridge rectifier that supplies 120 volts dc to the dc monitor circuit.

As long as the master control switch is on, power is fed to the tower control unit no matter what position the local/remote control unit switch is in. When the

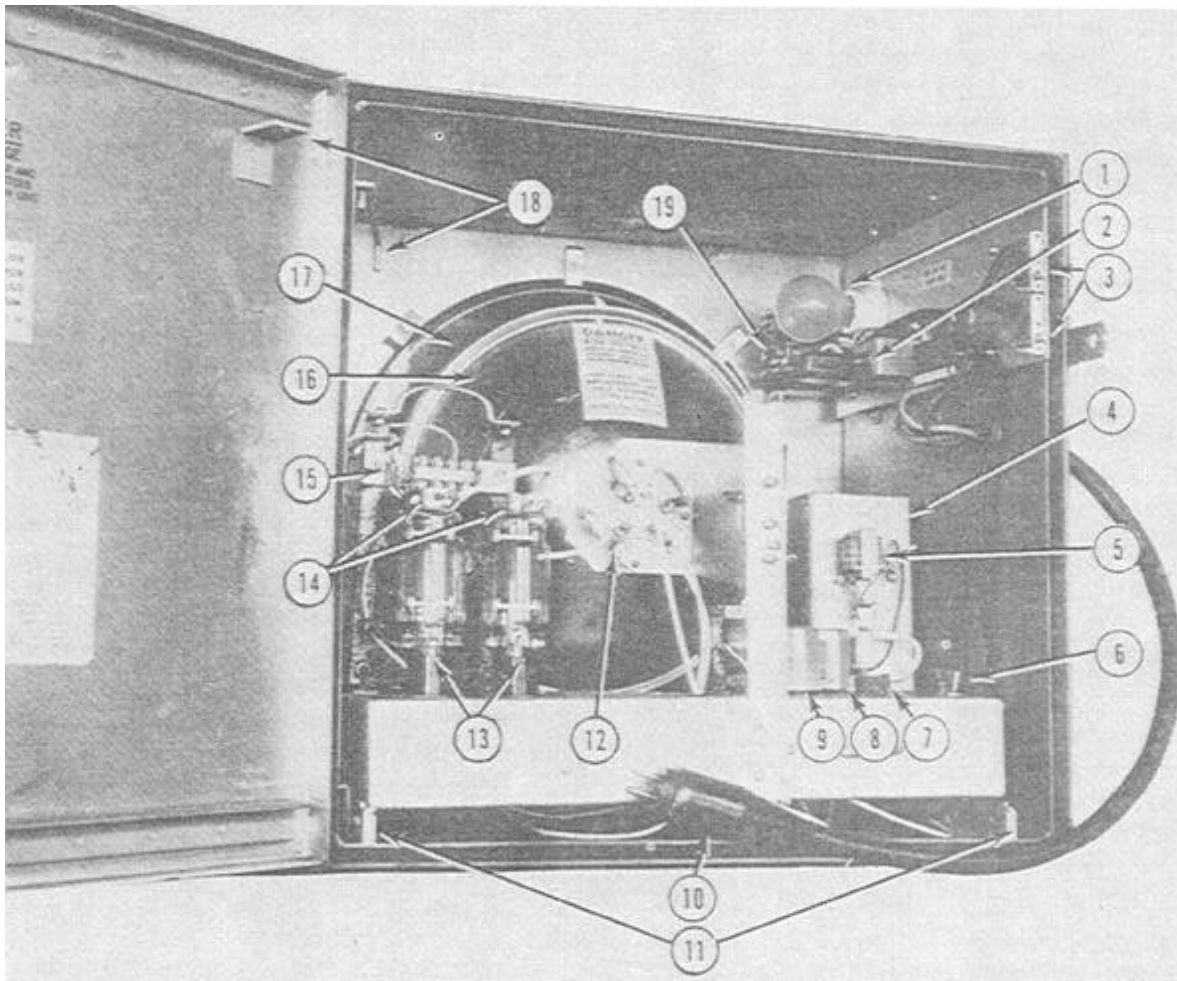

- | | |
|------------------------------------|---------------------------|
| 1. Cabinet light (240 V) | 11. Tracks |
| 2. Light switch and fuse | 12. Flashtube socket |
| 3. Safety interlock switches | 13. Rectifier tubes |
| 4. Flash capacitor | 14. Plate caps |
| 5. Capacitor bleeder relay | 15. Transformer |
| 6. Fuse and switch, 240-volt power | 16. Reflector |
| 7. Connector receptacle | 17. Glass |
| 8. Monitor relay | 18. Door stop and bracket |
| 9. Trigger relay | 19. Lightning arresters |
| 10. Four-pin connector | |

Figure 6-41.—Condenser discharge strobe light unit.

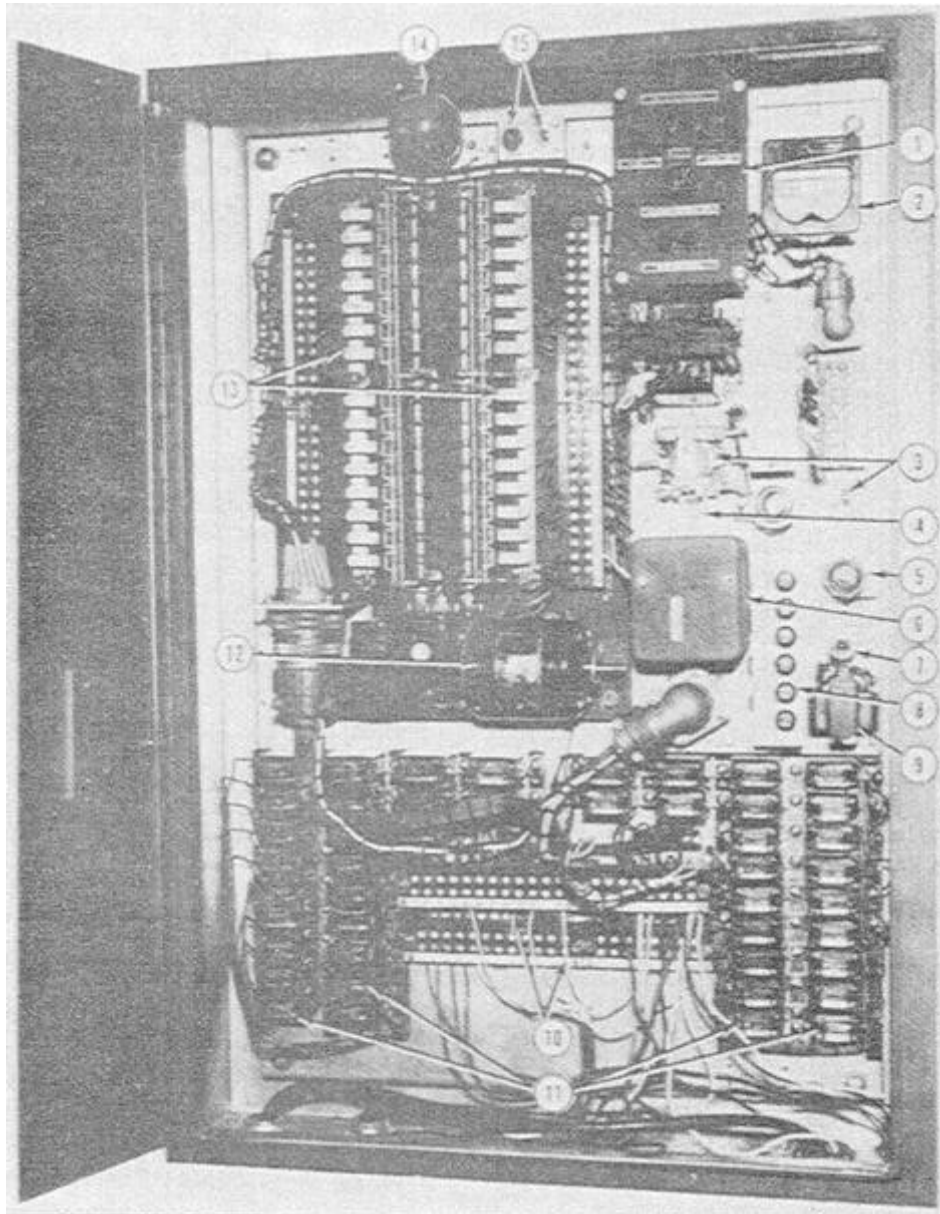

- | | |
|--------------------------------|-------------------------------|
| 1. Local/remote control | 9. 12-volt transformer |
| 2. Elapsed time meter | 10. Terminal blocks |
| 3. Main relay and switch | 11. Lightning |
| 4. Sensitivity rheostat | 12. Timer motor |
| 5. Sensitivity selector switch | 13. Timer switches |
| 6. DC power supply | 14. Cabinet light (240 volts) |
| 7. DC regulator tube | 15. Fuse and light switch |
| 8. Fuses | |

Figure 6-42.—Master sequence timer and controls.

flasher control switch in the vault control unit is closed, the dc power interlock relay closes and energizes the monitor lights in the tower control unit. The unit responds in the same way as if the system were in full operation and working well. For this reason, the tower personnel must be notified when the switch in the local/remote control unit is in the OFF position. When the flasher control switch on the local/remote control unit is in the OFF or LOCAL-ON position, the red indicator lights tell you that the tower control unit is not in full operation.

There is a monitor-sensing relay to monitor the operation of the strobe lights. When all the light units are working correctly, there will not be enough current through the coil of the monitor-sensing relay to actuate the relay. A variable adjustable resistor can be adjusted so that there will be 7,333 ohms of resistance between the monitor-sensing relay and ground. A resistance of 7,333 ohms equals three 22-kilohm resistors in series. The monitoring circuit in each light unit has a 22-kilohm resistor. So, if you take the three 22-kilohm resistors out of the monitor control unit, the monitor-sensing relay actuates when at least three light units have ceased to work and their monitoring circuits are grounded, as described earlier.

The sensitivity selector switch lets you reduce the number of malfunctioning lights needed to actuate the monitor-sensing relay by increasing the current flowing through its coil. There are three 22-kilohm resistors in the monitor control unit. Each of these three resistors simulates the effect of a grounded monitor connection to one of the lights.

If the monitor-sensing relay is tripped, the monitor lights on the local/remote control unit will go out. At the same time, the monitor lights in the tower control unit go out and a buzzer sounds.

The adjustment for the sensitivity of the monitor system is made at the monitor and control chassis in the master sequence timer cabinet.

With all of the strobe lights operating and the sensitivity selector switch in the No. 1 UNIT position, the green monitor lamps should be on. If you turn the strobe light units on and the monitor lights do not come on, you need to adjust the sensitivity of the variable resistor (sensitivity rheostat). You need a small screwdriver to fit the slot in the rheostat shaft (No. 4). Turn the shaft clockwise as far as it will go (about half a turn). The green lamps should now be lit. Now, turn the rheostat counterclockwise slowly until the green lamps go out. Then turn the rheostat back clockwise

slowly and stop as soon as the green lamps light. Check this setting by slipping a piece of paper between the contacts of one of the timer switches. The monitor lamps should go out. Remove the paper and turn the control switch to OFF for a few seconds and then to ON. The green lamps should now stay lit. Repeat this procedure for different lamps and shift the rheostat slightly if you need to until you find a setting that will operate for any of the approach lights.

Change the sensitivity selector switch to the No. 2 UNIT position and repeat the procedure while blocking two of the switches with pieces of paper. That is like having two strobe light units out and should have the same results as before. Restore the monitor lights the same as before. Repeat the procedure with the sensitivity switch in the No. 3 UNIT position while you block three of the timer switches. Now, check the operation of the monitor circuit with number 1, 2, and 3 strobe lights out.

When you find the correct setting of the rheostat, no further adjustments should be needed. When your base requires the selector switch to be on the No. 1 UNIT position, then, in proper operation, if one strobe light fails, the alarm is silenced by just moving the selector switch to the No. 2 UNIT position. The switch is left in this position until the bad strobe light is fixed. At that time, the selector is returned to the No. 1 UNIT position.

MASTER SEQUENCE TIMER.—The master sequence timer controls the order and rate of the triggering impulses to the light units. The timer has two camshafts driven by a motor (No. 12) through a reduction gear. The cams actuate 30 contacts (No. 13)—one for each light unit—staggered on the shafts so that the contacts are closed in rapid succession as the shafts turn. Note that although there are 30 contacts, only 28 are used. Each of the 28 contacts is electrically connected to one of the light units. Thus, when the motor is energized, the contacts are momentarily closed in a predetermined sequence twice each second. That provides a series of 120-volt ac pulses to the trigger relays in the lights. These pulses are known as the timing circuit. Power for the 120-volt motor and the 120-volt timing pulses comes from the monitor and control chassis. An elapsed time meter (No. 2) is mounted next to the timer to show the total time the equipment has been in use; thus it serves as a guide for maintenance. Forty-five lightning arresters (No. 11) are installed in the lower part of the cabinet to protect the equipment from voltage surges on any of the lines.

Tower Control Unit

The control switch on the tower control unit works only when the local/remote control unit in the timer cabinet is in the REMOTE position. The audible and visible monitoring alarms, however, are operable whenever the system is in use, even if the local/remote unit is at the LOCAL-ON position. Adjustments are provided on the panel for regulating the brightness of the two green monitor lights and the loudness of the buzzer. A push-button switch is used to test the operation of the buzzer.

MAINTENANCE OF AIRFIELD LIGHTING SYSTEMS

Regardless of the design of an airfield system, maintenance is highly recommended to ensure the operational dependency of the field. Routine scheduled downtime is much better than unscheduled downtime in the midst of an operation. Simple visual inspection plus periodic resistance readings of circuit devices, components, and cables reveal probable trouble areas.

Do not get caught in the “jury-rigged trap.” This tendency to patch, bypass, piece together, or otherwise rig a system to work “just for a little while” can be as dangerous as a coiled rattlesnake. That “temporary fix” is just sitting there waiting to catch some uninformed individual sent **out** to work on the system. This section covers routine maintenance for airfield lighting and underground systems, troubleshooting cable systems, and cable splicing and repair.

ROUTINE MAINTENANCE

Routine maintenance includes, but is not limited to, cleaning, adjusting, lubricating, painting, and treating for corrosion. Components and connections must be checked for condition and security. The insulation of the conductors should be checked for good condition and burns, scrapes, breaks, cracks, or evidence of overheating.

Visual Inspection

During your visual inspection of an airfield lighting wiring system, you should check the constant-current regulator (CCR) for chipped or cracked porcelain bushings, correct connections, proper fuses and switches, and relays for freedom of movement. Only relay panel covers should be removed. It is not

necessary to open the main regulator tank. All covers that are removed should be cleaned and then reinstalled tightly. Cable and isolation transformer connectors require close visual inspections for cuts, bruises, or other mishandling; these conditions could cause premature failure to the system. The mating surfaces of these molded rubber connectors must be clean and dry when they are plugged together. Either dirt or moisture prevents the mating surfaces from making complete surface contact and **causes a** failure at the connector. When connectors are plugged together, trapped air can cause them to disengage partially. Wait a few seconds and push them together again. Apply two or three turns of tape to hold them in place. When the connectors are clean, dry, and taped properly, the connection is equal or superior to a high-voltage splice.

Check light fixture connections for tightness. Look for cable bends that are too sharp; sharp bends can cause insulation breakdown or connector failure.

Operational Check

Once all components of the system have been visually inspected for damage and the cable system has been checked with a megger and hi-pot, make an operational check of the entire airfield lighting system.

1. Working from the control tower with an observer in the vault, operate each switch of the airport and taxiway panel, so that each position is reached at least twice. You must have radio or telephone communication with the observer in the vault during this operation. The observer in the vault determines that each switch properly controls its corresponding circuit.

2. Repeat this operation from the vault (alternate control panel) in the same manner, assuring that each switch position is reached twice.

3. Now, repeat the test by using the local control switches on the regulator.

4. Operate each lighting circuit at maximum brightness for 6 continuous hours. Make a visual inspection of all lights, both at the beginning and at the end of this test to assure that the proper number of lights are operating at full brightness. Measure lamp terminal voltage on at least one lamp in each multiple circuit to assure that this voltage is within ± 5 of the rated lamp voltage. Dimming of some or all of the lights in a circuit indicates grounded cables.

Condenser Discharge Light System

Periodic maintenance of this system is fairly simple. **Remember**, however, that **high voltages exist** in the components of the system and you must be extra careful. One such area is the **flash capacitor**. This capacitor may contain as much as 2,000 volts. **Anyone working on the light fixture should make sure that this capacitor is discharged before working on the light unit.** The capacitor should bleed down through its resistor network in 5 seconds; however, the capacitor should be shorted out before any work is done inside the unit. In a flush unit short between terminals 7 and 10 of the terminal board with a shorting stick. In the elevated light, short the two contacts on the left side of the flashtube socket. **That must be done before any work is done inside the light unit, such as changing a flashtube or cleaning the reflector.**

WARNING

Anyone working on a condenser discharge light system must make sure that the capacitor is discharged before working on the light unit.

Since these are sealed units, cleaning the reflectors rarely should be required. When such cleaning is required, be sure to use a nonabrasive cleaner. The lenses in both the 'elevated and flush units should be cleaned periodically, depending on the local conditions.

Inspect the timer contacts to see that they are clean and making good contact. If not, the stationary timer contacts can be adjusted. The timer gears of the master sequence timer require periodic lubrication. Match the grease to the ambient temperatures expected in your particular area. **NEVER use a graphite-based grease, as graphite is electrically conductive.** Check to see that both pairs of green indicator lights will light. When only one lamp is lit on either unit, the other bulb has burned out. To replace one of these bulbs, remove the front panel, pull off the colored lens, push out the old bulb, and insert the new bulb from the front of the panel. Replace the lens and panel.

Underground Distribution System

Normally speaking, underground systems that are properly installed require little maintenance of the routine type. Since both the equipment and the cable are well protected from man and the elements, the system normally is not subject to the same problems that overhead systems experience.

In some areas, groundwater or dampness may create some problems for underground systems by increasing rust or corrosion. Racks and splice boxes may require more painting and other rust or corrosion maintenance. Look especially for rusted nuts on boxes and rack hangers. They should be cleaned and painted. The manholes and vaults should be cleaned. These areas should not be used for storage or should trash be allowed to collect in them.

Check the manhole walls for evidence of cracks, breaks, or other evidence of water seepage or leakage. Check empty ducts for plugs and evidence of water seepage.

You will find manholes with enough water in them to hamper or prohibit work operations. In such cases, bail the water out with a bucket and rope or pump it out with a manhole pump. Sometimes sump holes are built into the floor of manholes, and these provide places to bail from or to pump from the lowest places in the manhole. When water runs into a manhole from unoccupied ducts, hard rubber plugs are provided to stop or slow the water. When the manhole pump is used, place it in a position so the flow of water will be away from the manhole. That would be on the downhill side. Place the pump at least 10 feet from the manhole opening. The pump has a hose to be inserted in the manhole and an outlet hose to carry the water away from the manhole. Check cables for proper racking, making sure that they are trained in the proper direction and positioned so an ample cable radius is left for bends and expansion/contraction. This radius is basically 5 to 12 times the cable diameter, depending on the sheath type and the number of conductors. Make sure that 6 inches of straight cable exists for racking on each side of the splice. Check splices for evidence of leakage or tracking. Look for scrapes, burns, cracks, corrosion, or any other evidence of cable insulation deterioration. See that all cables are properly tagged for identification.

Check potheads and terminations that are attached to risers for leakage, tracking, and evidence of overheating or an overvoltage. Also, check the security of the mounting of the pothead and conduit.

TROUBLESHOOTING CIRCUITS

Troubleshooting of cable systems is much the same as any other type of electrical troubleshooting. You need a thorough knowledge of the system as well as the ability to analyze problems. A review of the history of the system provides clues to present or future troubles. Simply using your eyes and head is

sometimes the most effective method of locating the trouble. A knowledge of test equipment, an ability to read drawings or schematics, and an understanding of electricity are the key factors in locating electrical troubles.

Types of Trouble

The same basic types of trouble can occur in the airfield lighting cable system whether that system is in series or in multiple; however, the results of these circuit troubles can cause dramatic differences; for instance, a short circuit across the terminals of a distribution transformer supplying a multiple system is a dangerous overload; and the same short circuit across the output terminals of a CCR and series transformer is a no-load condition. An open in the output circuit of a CCR, on the other hand, creates a dangerous overload. Burned-out lamps in the secondary of a series circuit will not damage the transformer, but the secondary voltage will rise above normal and distort the wave shape of the primary current. When enough lamps burn out, the primary current may rise high enough to shorten lamp life and possibly damage the regulator. These critical factors should tell you why you need to know the circuit.

In the discussion above, all types of electrical trouble were mentioned; for example, opens, shorts, grounds, and improper power.

OPENS.—An open circuit is an incomplete circuit. Somewhere the circuit has a break; therefore, there is not a complete path for current flow throughout the circuit. Because there is no current flow, the circuit cannot operate. In analyzing circuit trouble, if the lights are not burning, the motor is not running, and so forth, you need to look for a break in the circuit. Usually this break will be at the unit(s) of resistance (burned-out lamp, broken resistor, motor burned out), but sometimes the break will happen in the cable. When the cable breaks, this break is most likely to happen at a splice or connection. Other cable breaks may be caused by digging operations being done in the wrong place. That occurs when base maps are not kept up to date and when unauthorized digging operations take place. It is an excellent reason for installing and maintaining direct burial cable markers.

Improper installation of cables can cause them to fail. Cables may be damaged by kinking, bruised by rocks, crushed by wheels, or cut by shovels when proper care is not exercised during handling and

installation. While the damage at the time it occurs may not be great enough to take the cable out of service, it may be the starting point for a cable failure at a later date. This failure may be either in the form of a broken cable (open), cross type of short (two cables touching), or a short to ground (cable in contact with earth ground). Any of these troubles can render the circuit inoperative. The indication of the type of trouble that you have in the circuit and the point in the circuit where this indication appears should assist you in locating and repairing the circuit.

With an open circuit, that portion of the lighting system being supplied by the effected cable will not operate. A string of lamps that do not light, then, would indicate an open cable.

SHORTS.—If lamps are lit when they are not supposed to be or if a circuit is affected by another circuit, you most likely have a cross type of short between the two circuits. The logical point to start looking for this trouble is where the two cables cross or where they are close to each other.

GROUNDS.—When a string of lights burns dim or when fuses blow on a circuit, you have a short to ground. The insulation on the supply cable is damaged. This defect lets current pass directly from the conductor to the earth and prevents the lamps from receiving enough power to operate correctly; that is, some of the resistance of the circuit is being bypassed. The amount of resistance being bypassed in the circuit governs the effect of the short to ground. If enough resistance is removed (bypassed), then the current rises to a point that is sufficient to blow the fuses and thus disconnect the circuit.

IMPROPER POWER.—Improper power can result when regulators or distribution transformers are not connected properly. If the incorrect input voltage is connected or if the regulator has been purposely connected for an unusual load requirement, improper power can be applied to the system and serious damage may result.

Underground Lighting Problems

The care and craftsmanship of the original installation will, to a large extent, determine the life of the system. Still, no system lasts forever. Even the best installation and the most conscientious inspection and maintenance program cannot prevent the aging and gradual breakdown of a system. In almost all cases when an underground cable breaks down, it goes to ground. Where more than one conductor is enclosed in

one sheath, the insulation within the sheath may deteriorate so that a cross type of short occurs. This contact almost always creates enough heat and pressure to rupture the sheath and put the conductors in contact with ground.

Moisture is one of the most common causes of an underground system breakdown. Impurities in the water help set up corrosion cells, break down neoprene, and rot rubber. Only a trace of moisture, when superheated by the electrical power of the circuit and converted to steam, can cause an explosion that will rip the cable to shreds. Groundwater contains enough minerals to provide an excellent conductor to all other parts of the system. Some underground cables are bonded together. The usual way to find out that an underground power cable has a problem is to check when the circuit opens.

In ducted systems, the maximum runs between manholes are 500 feet. The normal method of repair is to replace the cable. In direct burial cable systems, the

cable runs may be quite long, and it would be impractical to replace the entire run. In this case, cable fault locators are used to locate the fault. Before starting to work, make sure that all power is off on the circuits in the trench before you start digging or repairing the cable.

This chapter does not discuss detailed circuit troubleshooting because each system is different. When you troubleshoot complex problems that involve airfield lighting, you should refer to the following publications: *Definitive Designs for Naval Shore Facilities*, NAVFAC P-272; *General Requirements for Shorebased Airfield Marking and Lighting*, NAVAIR 51-50AAA-2; and *Lighting and Marking Systems for Expeditionary Airfields*, NAVAIR 51-4OABA-7. Problems, such as improper power connections, component connections, safety grounding, cable splices, cable terminations, and cable installations, are discussed in detail in these publications.

CHAPTER 7

ELECTRICAL EQUIPMENT

INTRODUCTION

As a Construction Electrician, you will encounter many pieces of electrical equipment and many appliances. A solid background in electrical theory and standards and a working knowledge of the components and of the machines themselves will allow you to install, maintain, troubleshoot, and repair a wide variety of equipment and appliances.

In one way or another, all machines use the same technologies. The differences are in the complexity of their operation and the tasks they perform. This chapter will not cover specific pieces of equipment or appliances but will concentrate on electrical components, motors, controllers, and circuitry that are common to most equipment and appliances.

In this chapter you will find many references to articles, parts, and sections of the National Electrical Code® (NEC®). You should have an NEC® book on hand while reading this chapter. The chapter text is written in general terms. Many of the exceptions given in the NEC® are not included. Look up the sections when they are referenced. The NEC® can be quite confusing, so **read the articles** closely and pay special attention to the notes and exceptions.

MOTOR-BRANCH CIRCUITS

A motor-branch circuit is a wiring system extending beyond the final automatic overload protective device. Thermal cutouts or motor overload devices are not branch-circuit protection. These are supplementary overcurrent protection. The branch circuit represents the last step in the transfer of power from the service or source of energy to utilization devices.

MOTOR-BRANCH-CIRCUIT SHORT-CIRCUIT AND GROUND-FAULT PROTECTION (NEC® 430, PART D)

The Code requires that branch-circuit protection for motor circuits must protect the circuit conductors, the control apparatus, and the motor itself against overcurrent caused by short circuits or grounds (sections 430-51 through 430-58). Fuses or circuit

breakers are the most common protectors used as branch-circuit protective devices. These protective devices must be able to carry the starting current of the motor. To carry this current, they may be rated 300 or 400 percent of the running current of the motor, depending on the size and type of motor.

Motor controllers provide motor protection against all ordinary overloads but are not intended to open during short circuits.

Motor-branch circuits are commonly laid out in a number of ways. Figures 7-1 through 7-3 show three motor-branch circuits and how the circuit protection is used in various types of layouts.

As mentioned before, the motor-branch-circuit short-circuit and ground-fault protective device must be capable of carrying the starting current of the motor. For motor circuits of 600 volts or less, a protective device is permitted that has a rating or setting that does not exceed the values given in table 430-152 of the Code. An instantaneous-trip circuit breaker (without time delay) may be used **ONLY** if it is adjustable and is part of a listed combination controller, having motor overload and also short-circuit and ground-fault protection in each conductor.

When values for branch-circuit protective devices, as shown in the NEC®, table 430-152, do not correspond to the standard sizes or ratings of fuses, nonadjustable circuit breakers, or thermal protective devices, you may use the next higher size, rating, or setting.

The National Electrical Manufacturer's Association (NEMA) has adopted a standard of identifying code letters that may be marked by the manufacturers on motor nameplates to indicate the motor kilovoltampere input with a locked rotor. These code letters, with their classification, are given in the NEC®, table 430-7(b). In determining the starting current to use for circuit calculations, use values from table 430-7(b). Exceptions to the above are given in table 430-52.

When maximum branch-circuit protective device ratings are shown in the manufacturer's overload-relay table for use with a motor controller or are marked on

LAYOUT #1

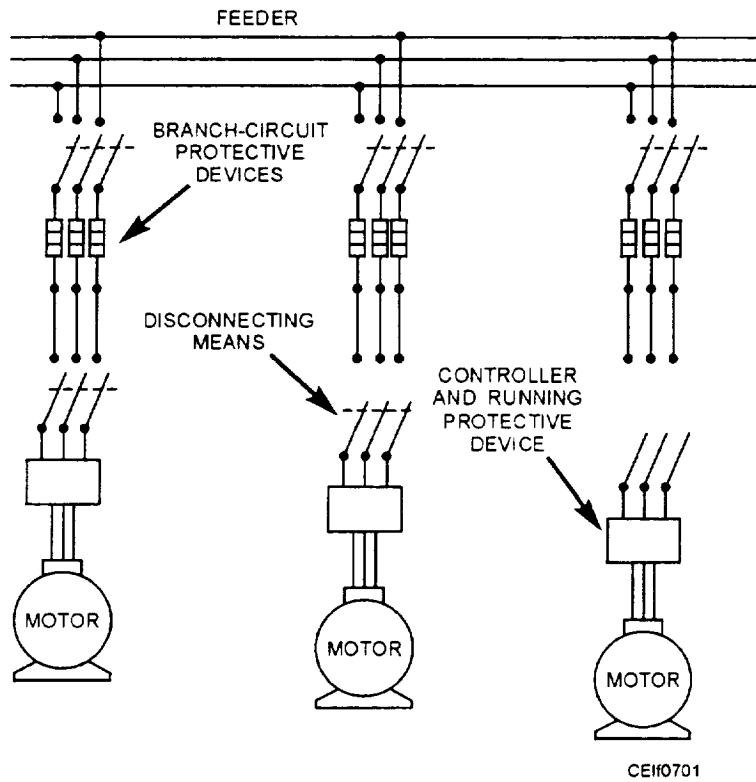

Figure 7-1.—Branch-circuit layout #1.

LAYOUT #2

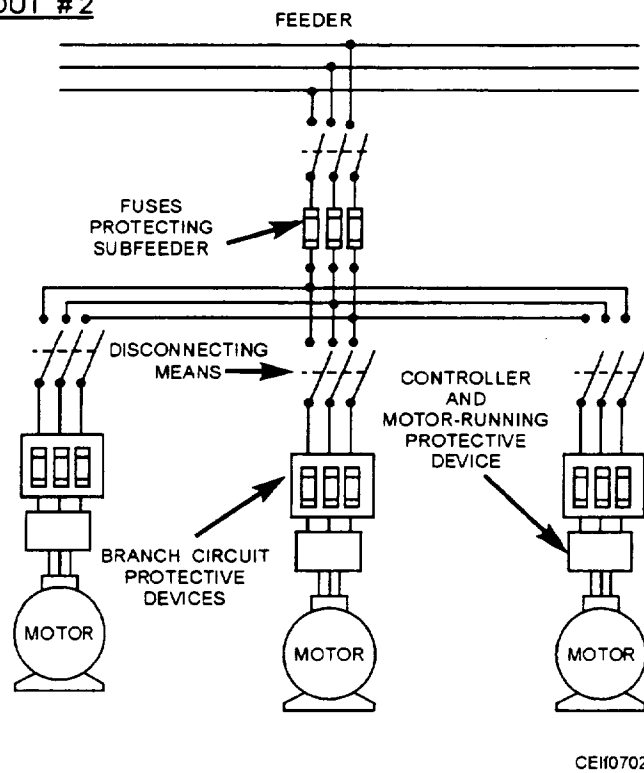

Figure 7-2.—Branch-circuit layout #2.

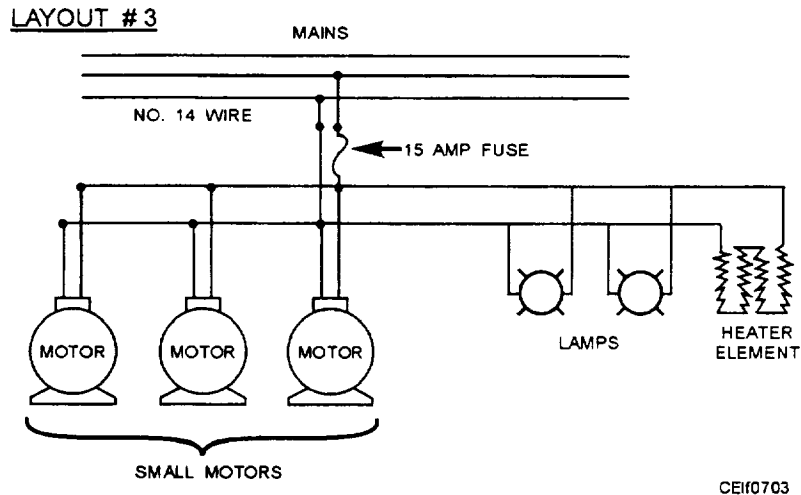

Figure 7-3.—Branch-circuit layout #3.

equipment, you may not exceed them even if higher values are indicated in table 430-152 of the NEC[®]; however, you may use branch-circuit protective devices of smaller sizes. If you use a branch-circuit device that is smaller, you only need to be sure that it has sufficient time delay to permit the motor-starting current to flow without opening the circuit.

Often it is not convenient or practicable to locate the branch-circuit short-circuit and ground-fault protective device directly at the point where the branch-circuit wires are connected to the mains. In such cases, the size of the branch-circuit wires between the feeder and the protective device must be the same as the mains unless the length of these wires is 25 feet (7.6 meters) or less. When the length of the branch-circuit wires is not greater than 25 feet, the NEC[®] rules allow the size of these wires to be such that they have an ampacity not less than one third of the ampacity of the mains if they are protected against physical damage.

Figure 7-4 gives you an example of branch-circuit conductor sizing, using the figures found in the NEC[®] tables 430-152 and 430-7(b).

SEVERAL MOTORS OR LOADS ON ONE BRANCH CIRCUIT

You may use a single-branch circuit to supply two or more motors or one or more motors and other loads according to section 430-53 of the Code. Some examples are as follows:

1. Several motors, each not exceeding 1 horsepower, are permitted on a branch circuit protected at not more than 20 amperes at 120 volts or less, or at

600 volts or less protected at not over 15 amperes if all of the following conditions can be met:

- The rating of the branch-circuit short-circuit and ground-fault protective device marked on the controllers is not exceeded.
- The full-load rating of each motor does not exceed 6 amperes.
- Individual overload protection conforms with section 430-32 of the NEC[®].

2. You may connect two or more motors of any rating to a branch circuit that is protected by a short-circuit and ground-fault protective device selected according to the maximum rating or setting of the smallest motor.

3. You may connect two or more motors of any rating and other loads to one branch circuit if the overload devices and controllers are approved for group installation and if the branch-circuit fuses or circuit-breaker rating is according to section 430-52 of the NEC[®].

MOTOR FEEDER SHORT-CIRCUIT AND GROUND-FAULT PROTECTION (NEC[®] 430, PART E)

Overcurrent protection for a feeder to several motors must have a rating or setting not greater than the largest rating or setting of the branch-circuit protective device for any motor of the group plus the sum of the full-load currents of the other motors supplied by the feeder.

Protection for a feeder to both motor loads and a lighting and/or appliance load must be rated on the

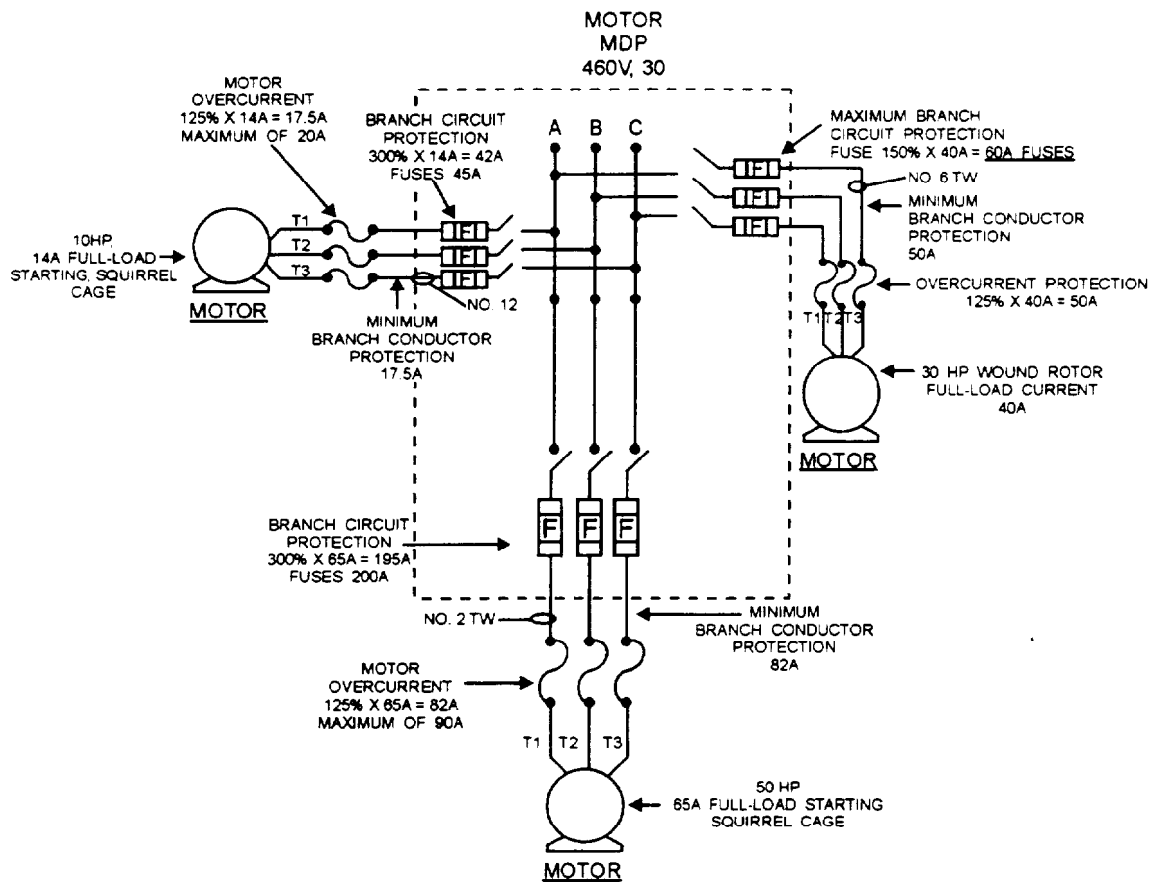

CEI#0704

Figure 7-4.—Branch-circuit conductor sizing.

basis of both of these loads. The rating or setting of the overcurrent device must be sufficient to carry the lighting and/or appliance load plus the rating or setting of the motor branch-circuit protective device.

MOTOR CONTROLLER PROTECTION (NEC® 430, PART G)

A controller is a device that starts and stops a motor by making and breaking the power current flow to the motor windings. A push-button station, a limit switch, or any other pilot-control device is not considered a controller. Each motor is required to have a suitable controller that can start and stop the motor and perform any other control functions required. A controller must be capable of interrupting the current of the motor under locked-rotor conditions (NEC® 430-151) and must have a horsepower rating not lower than the rating of the motor, exceptions as permitted.

Branch-circuit fuses or circuit breakers are considered to be acceptable controller devices under the following conditions:

- For a stationary motor rated at one-eighth horsepower or less that is normally left running and is constructed so that it cannot be damaged by overload or failure to start.
- For a portable motor rated at one-third horsepower or less, the controller may be an attachment plug and receptacle.

The controller may be a general-use switch having an ampere rating at least twice the full-load current rating of a stationary motor rated at 2 horsepower or less and 300 volts or less.

A branch-circuit breaker, rated in amperes only, may be used as a controller. When this circuit breaker is also used for short-circuit and ground-fault and/or overload protection, it will conform to the appropriate provisions of the NEC® governing the type of protection afforded. Figure 7-5 will help you to understand controller definitions.

Generally, each motor must have its own individual controller. The exception is for motors rated 600 volts or less; a single controller rated at not less than the sum of the horsepower ratings of all of the

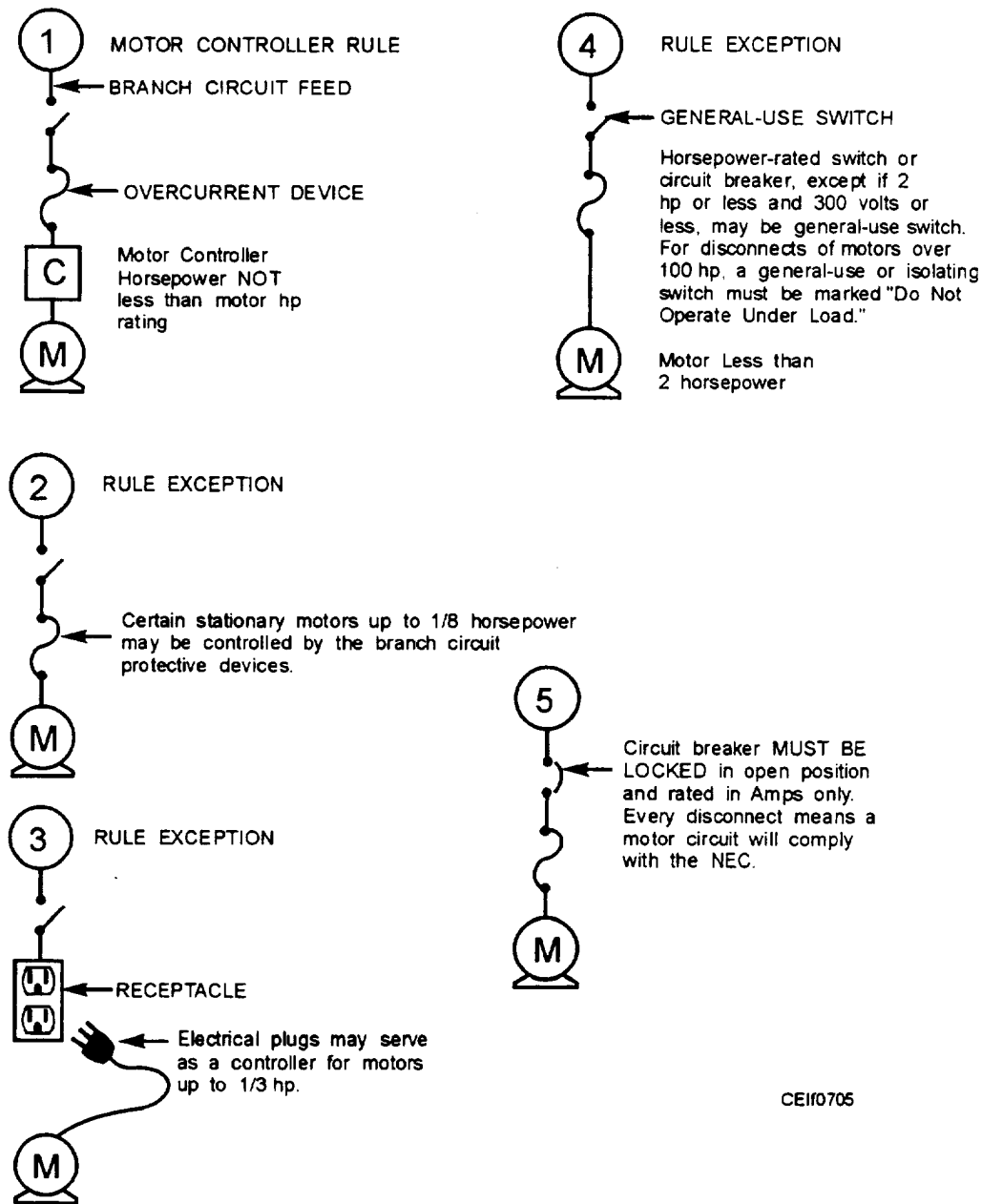

Figure 7-5.—Motor controllers basic rules and exceptions.

motors of the group should be permitted to serve the group of motors under any one of the following conditions:

- Where a number of motors drive several parts of a single machine or a piece of apparatus, such as metalworking and woodworking machines, cranes, hoists, and similar apparatus.
- Where a group of motors is under the protection of one overcurrent device, as permitted in *NEC*[®] section 430-53(a).
- Where a group of motors is located in a single room within sight of the controller location. A

distance of more than 50 feet (15.3 meters) is considered equivalent to being out of sight.

DISCONNECTING MEANS, MOTORS, AND CONTROLLERS (*NEC*[®] 430, PART H)

Each motor, along with its controller or magnetic starter, must have some form of approved manual disconnecting means, rated in horsepower, or a circuit breaker. This disconnecting means, when in the OPEN position, must disconnect both the controller and the motor from all ungrounded supply conductors. It must plainly indicate whether it is in the OPEN or the CLOSED position and may be in the same housing as the controller.

For motor circuits of 600 volts or less, the controller manual disconnecting means must be within sight and not more than 50 feet away from the location of the motor controller. There are two exceptions in the Code rule requiring a disconnect switch to be in sight from the controller:

1. For motor circuits over 600 volts, the controller disconnecting means is permitted to be out of sight from the controller, provided the controller is marked with a warning label giving the location and identification of the disconnecting means, and the disconnecting means can be locked in the OPEN position.

2. On complex machinery using a number of motors, a single common disconnect for a number of controllers may be used. This disconnect may be out of sight from one or all of the controllers if it is adjacent to them.

The Code also stipulates that a manual disconnecting means must be within sight and not more than 50 feet from the motor location and the driven machinery. The exception to this rule is that the disconnecting means may be out of sight if it can be locked in the OPEN position. See figure 7-5 for other exceptions and basic rules.

The *NEC*[®] rules allow a single switch to be the disconnecting means of a group of motors under 600 volts. Also, manual switches or circuit breakers rated in horsepower can be used as a disconnecting means and the controller for many motor circuits.

MOTOR AND BRANCH-CIRCUIT OVERLOAD PROTECTION (NEC[®] 430, PART C)

Each continuous-duty motor must be protected against excessive overloads under running conditions by some approved protective device. This protective device? except for motors rated at more than 600 volts, may consist of fuses, circuit breakers, or specific overload devices. Overload protection will protect the branch circuit, the motor, and the motor control apparatus against excessive heating caused by motor overloads. Overload protection does not include faults caused by shorts or grounds.

Each continuous-duty motor rated at more than 1 horsepower must be protected against overload by one of the following means:

1. A separate overload device that is responsive to motor current. This device is required to be rated or

selected to trip at no more than the following percentage of the motor nameplate full-load current rating:

MOTOR	PERCENT
Motors with a marked service factor not less than 1.15	125
Motor with a marked temperature rise not over 40°C	125
All other motors	115

For a multispeed motor, each winding connection must be considered separately. Modification of these values is permitted. See section 430-34.

2. A thermal, protector, integral with the motor, is approved for use with the motor that it protects on the basis that it will prevent dangerous overheating of the motor caused by overload and failure to start. The percentages of motor full-load trip current are given in section 430-32 (a-2).

3. A protective device, integral with the motor, that will protect the motor against damage caused by failure to start is permitted if the motor is part of an approved assembly that does not normally subject the motor to overloads.

Nonportable, automatically started motors of 1 horsepower or less must be protected against running overload current in the same manner as motors of over 1 horsepower, as noted in section 430-32 (c).

Motors of 1 horsepower or less that are manually started, within sight of the controller location and not permanently installed are considered protected by the branch-circuit protective device.

FUSES FOR MOTOR-OVERLOAD PROTECTION (NEC[®] 430, PART C)

If regular fuses are used for the overload protection of a motor, they must be shunted during the starting period since a regular fuse having a rating of 125 percent of the motor full-load current would be blown by the starting current. Many dc-motor and some wound-rotor-induction-motor installations are exceptions to this rule. Aside from these exceptions, it is not common practice to use regular fuses for the overload protection of motors. Time-delay fuses sometimes can be used satisfactorily for overload protection since those rated at 125 percent of the motor full-load current will not be blown by the starting

current. In fact, the manufacturers of these fuses recommend that for ordinary service, fuses of a smaller rating than 125 percent of the motor full-load current be used.

Even time-delay fuses may not be satisfactory unless they are shunted during the starting period because the 125 percent value cannot be exceeded.

OVERLOAD DEVICES OTHER THAN FUSES (NEC® 430, PART C)

The NEC® (table 430-37) indicates the number and location of overload protective devices, such as trip coils, relays, or thermal cutouts. These overload devices are usually part of a magnetic motor controller. Typical devices include thermal bimetallic heaters, resistance or induction heaters, and magnetic relays with adjustable interrupting and/or time-delay settings. Overload devices can have a manual or automatic reset.

THERMALLY PROTECTED MOTORS (NEC® 430, PART C)

Thermally protected motors are equipped with built-in overload protection, mounted directly inside the motor housing or in the junction box on the side. These devices are thermally operated and protected against dangerous overheating caused by overload, failure to start, and high temperatures. The built-in protector usually consists of a bimetallic element connected in series with the motor windings. When heated over a certain temperature, the contacts will open, thereby opening the motor circuit. On some types, the contacts automatically close when cooled, or a reset button must be operated manually to restart the motor.

PROTECTION OF LIVE PARTS (NEC® 430, PART K)

The NEC® requires that live parts be protected in a manner judged adequate to the hazard involved. The following rules apply:

1. Exposed live parts of motors and controllers operating at 50 volts or more between terminals must be guarded against accidental contact by enclosure or by location as follows:

- a. By installation in a room or enclosure accessible only to qualified persons
- b. By installation on a suitable balcony, gallery, or platform so elevated and arranged as to exclude unqualified persons

c. By elevation 8 feet (2.4 meters) or more over the floor

2. If the live parts of motors or controllers, operating at more than 150 volts to ground, are guarded against accidental contact only by location, as specified in paragraph I, and if adjustment or other attendance may be necessary during the operation of the apparatus, suitable insulating mats or platforms must be provided so that the attendant cannot readily touch live parts without standing on the mats or platforms.

EQUIPMENT GROUNDING

An equipment ground refers to connecting the noncurrent-carrying metal parts of the wiring system or equipment to ground. Grounding is done so that the metal parts a person might come into contact with are always at or near ground potential. With this condition, there is less danger that a person touching the equipment will receive a shock.

GROUNDING EQUIPMENT FASTENED IN PLACE OR CONNECTED BY PERMANENT WIRING METHODS (FIXED) (NEC® 250, PART E)

The word *fixed*, as applied to equipment requiring grounding, now applies to equipment fastened in place or connected by permanent wiring, as shown in figure 7-6. That usage is consistently followed in other Code sections also.

The Code requires that all exposed noncurrent-carrying metal parts, such as equipment enclosures, boxes, and cabinets, must be grounded. Equipment must be grounded where supplied by metallic wiring methods; in hazardous locations; where it comes into contact with metal building parts; in wet, nonisolated locations; within reach of a person who is in contact with a grounded surface; and where operated at over 150 volts.

METHODS OF GROUNDING (NEC® 250, PART F)

Section 250-51 sets forth basic rules on the effectiveness of grounding. This rule defines the phrase effective grounding path and establishes mandatory requirements on the quality and quantity of conditions in any and every grounding circuit. The three required characteristics of grounding paths are very important for safety:

1. That every grounding path is permanent and continuous. The installer can ensure these conditions by

If the equipment is not fastened to the floor, wall, shelf, or other support and is fed by permanent wiring it is called "fixed equipment."

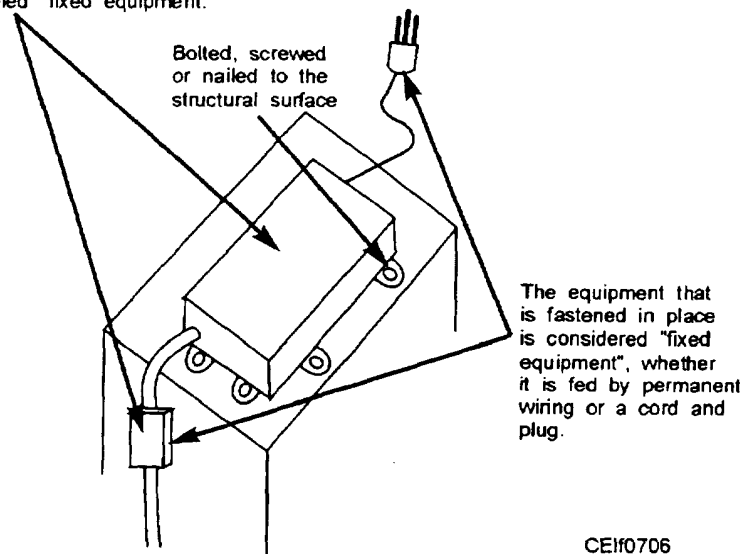

CEI#0706

Figure 7-6.—Definition of fixed equipment.

proper mounting, coupling, and terminating of the conductor or raceway intended to serve as the grounding conductor. The installation must be made so that it can be inspected by an electrical inspector, the design engineer, or any other authority concerned. A continuity test with a meter, a light, or a bell will assure that the path is "continuous."

2. That every grounding conductor has the capacity to conduct safely any fault current likely to be imposed on it. Refer back to the section of the Code that specifically establishes a minimum required size of grounding conductor.

3. That the path to ground has sufficiently low impedance to limit the voltage to ground and to facilitate the operation of the circuit protective devices in the circuit.

USE OF GROUNDED CIRCUIT CONDUCTOR FOR GROUNDING EQUIPMENT (*NEC*[®], SECTION 250-61)

Part (a) of *NEC*[®], section 250-61, permits the grounded conductor (usually the neutral) of a circuit to be used to ground metal equipment enclosures and raceways on the **supply side** of the service disconnect. Figure 7-7 shows such applications. At (A), the grounded service neutral is bonded to the meter housing by means of the bonded neutral terminal lug in the socket. The housing is thereby grounded by this connection to the grounded neutral, which itself is

grounded at the service equipment as well as at the utility transformer secondary supplying the service. At (B), the service equipment enclosure is grounded by connection (bonding) to the grounded neutral, which itself is grounded at the meter socket and at the supply transformer. These same types of grounding connections may be made for cabinets, auxiliary gutters, and other enclosures on the line side of the service entrance disconnect means, including the enclosure for the service disconnect. At (C), equipment is grounded to the neutral on the line (supply) side of the first disconnect fed from a step-down transformer (a separately derived system).

Aside from the permission given in the five exceptions to the rule of part(b) of section 250-61, the Code prohibits connection between a grounded neutral and equipment enclosures on the **load side** of the service. So bonding between any system grounded conductor, neutral or phase leg, and equipment enclosures is prohibited on the load side of the service (fig. 7-8). The use of a neutral-to-ground panelboard or other equipment (other than specified in the exceptions) on the load side of service equipment would be extremely hazardous if the neutral became loosened or disconnected. In such cases, any line-to-neutral load would energize all metal components connected to the neutral, creating a dangerous potential for electrocution. Hence such a practice is prohibited. This prohibition is fully described in figure 7-9.

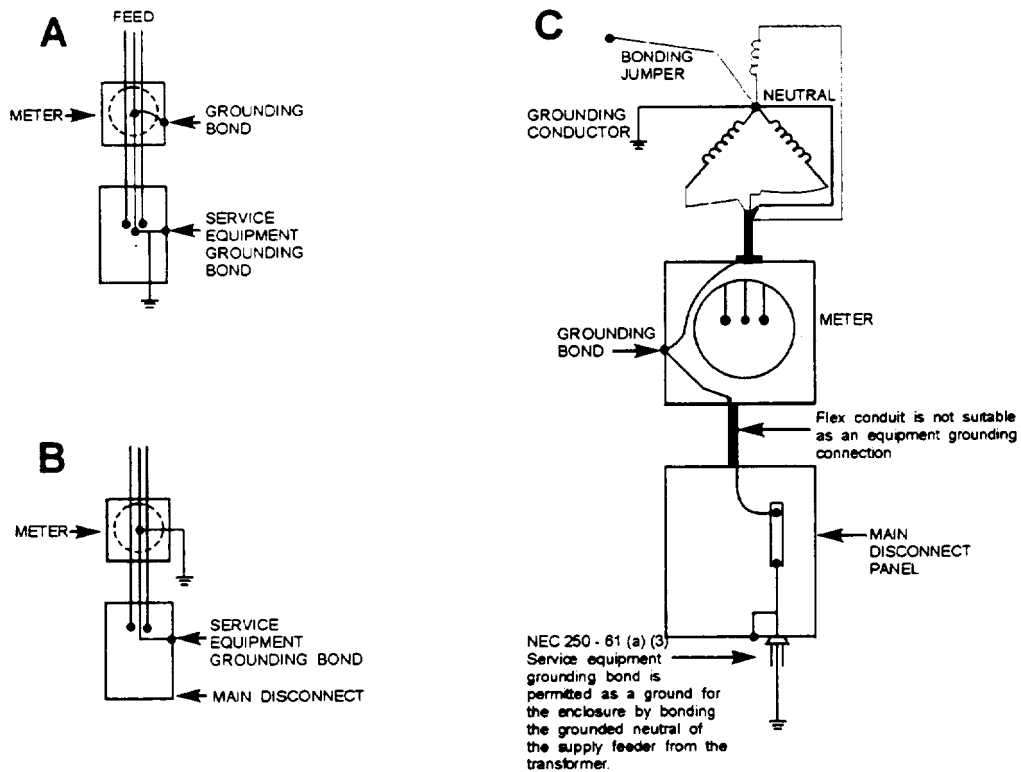

CEIf0707

Figure 7-7.—Equipment housing ground connections (line side).

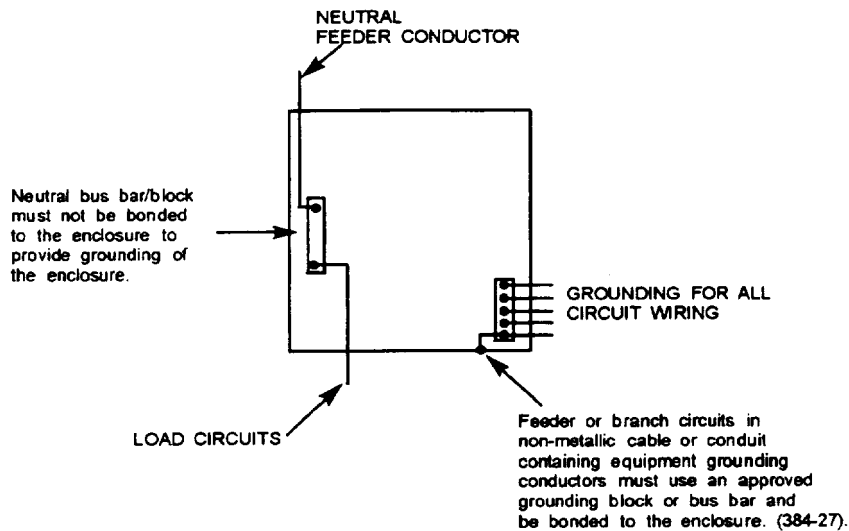

CEIf0708

Figure 7-8.—Equipment housing ground connections (load side).

Although this rule of the Code prohibits neutral bonding on the load side of the service, sections 250-50(a) and 250-53(b) clearly require such bonding at the **service entrance**.

The circuit conductors used for equipment grounding must be within the same raceway, cable, or

cord or run with the circuit conductors. The conductors may be bare or insulated. The insulated conductors must have a continuous outer finish of green or green with one or more yellow stripes.

When the equipment grounding is to be accomplished by the protective device of the circuit

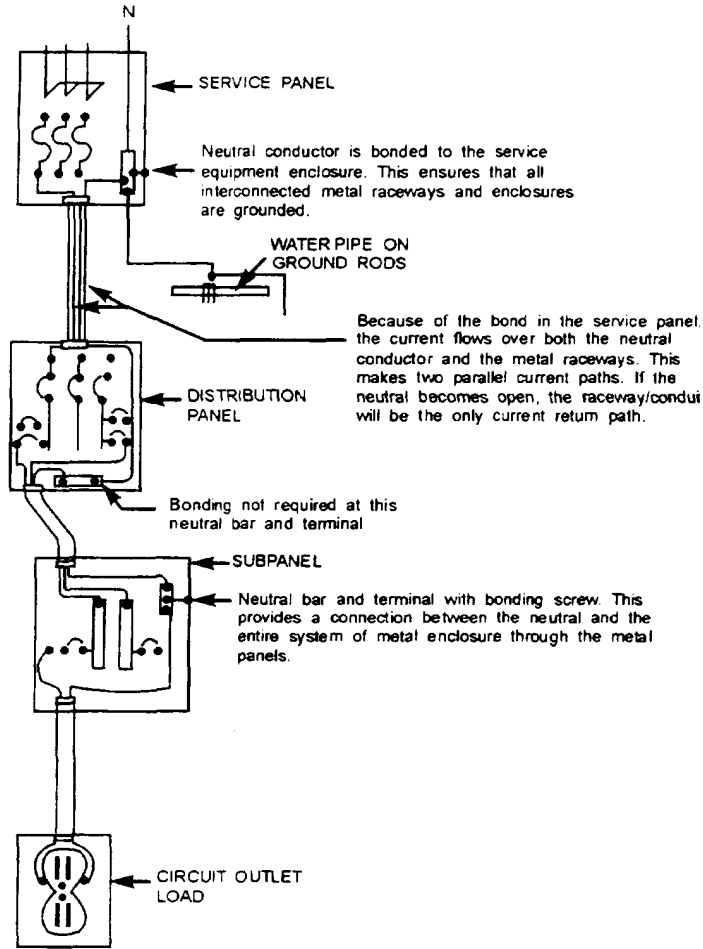

A HAZARD CONDITION EXISTS:

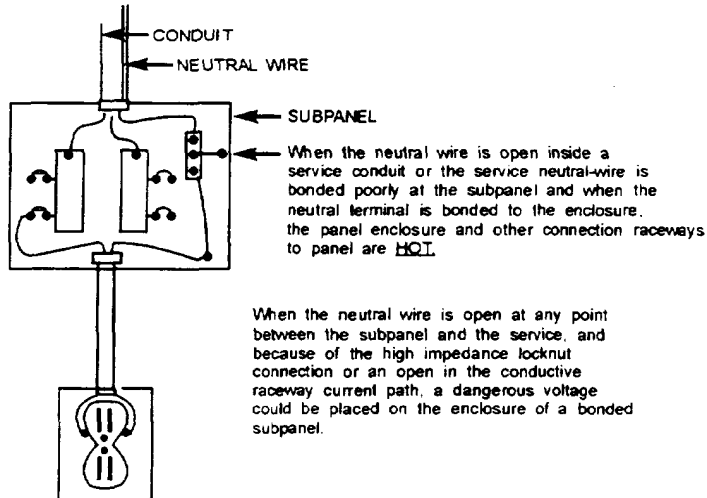

CE#0709

Figure 7-9.—Subpanel bonding hazards.

conductors, it must be rigid metal conduit, intermediate metal conduit, electrical metallic tubing, flexible metal conduit, type AC cable, or the combined metallic sheath and grounding conductors of type MC cable.

Flexible metal conduit is permitted as an equipment grounding conductor if the following conditions are met: the length of the flex does not exceed 6 feet, the circuit conductors within are rated at 20 amperes or less, and the connectors are fittings listed for grounding. If the 6 feet of flex is exceeded, a bonding jumper wire, run inside the flex, must be used.

CONTROL CIRCUITS

The subject of electric control circuits is quite broad. The following text will cover a few of the basic control circuit requirements and controls. For more information, refer to special books devoted to this important phase of motor circuitry. Two such books are *Electric Motor Control* by Walter N. Alerich and *Electric Motor Repair* by Robert Rosenberg and August Hand. These textbooks provide an excellent insight on how to understand, select, and design control circuits.

CONTROL CIRCUITS GENERAL (NEC® 430, PART F and ARTICLE 725)

A control circuit is a circuit that exercises control over one or more other circuits. These other circuits controlled by the control circuit may themselves be control circuits, or they may be “load” circuits that carry utilization current to a lighting, heating, power, or signal device. Figure 7-10 clarifies the distinction between control circuits and load circuits.

The elements of a control circuit include all the equipment and devices concerned with the function of the circuit: conductors, raceway, contactor-operating coil, source of energy supply to the circuit, overcurrent protective devices, and all switching devices that govern energization of the operating coil.

Typical control circuits include the operating-coil circuit of magnetic motor starters, magnetic contactors, and relays. Control circuits include wiring between solid-state control devices as well as between magnetically actuated components. Low-voltage relay switching of lighting and power loads also are classified as remote-control wiring.

A control circuit is divided into three classes:

- Class 1 system may operate at any voltage that does not exceed 600 volts. They are, in many cases, merely extensions of light and power systems, and, with a few exceptions, are subject to all the installation rules for light and power systems.

- Class 2 and Class 3 systems are those systems in which the current is limited to certain specified low values. This limiting may be accomplished by fuses or circuit breakers, by transformers that deliver only very small currents, or by other voltages at which the system operates from 5 milliamps or less. All Class 2 and Class 3 circuits must have a power source with the power-limiting characteristics described in NEC®, table 725-31(a). These requirements are in addition to the overcurrent device.

Conductors for any Class 1 control circuit must be protected against overcurrent. Number 14 and larger wires must generally be protected at their ampacities. (Review NEC®, table 310-16.) Number 18 and Number 16 control wires must always be protected at 7 and 10 amperes, respectively.

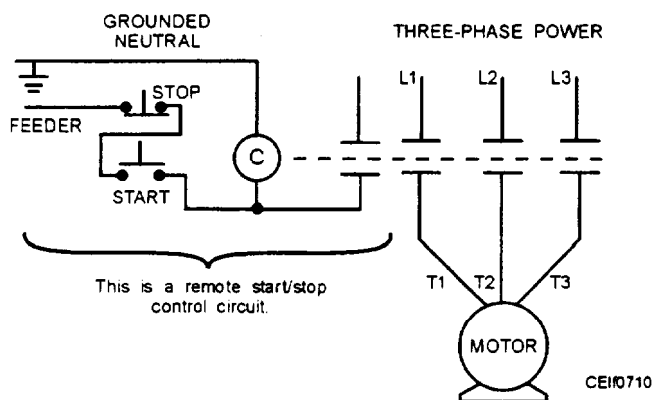

Figure 7-10.—Defining a control circuit.

Any number and any type of Class 1 circuit conductors may be installed in the same conduit, raceway, box, or other enclosure if all conductors are insulated for the maximum voltage at which any of the conductors operates and the wires are functionally associated with each other.

Class 1 circuit wires may be run in raceways by themselves according to the *NEC*[®]. The number of conductors in a conduit must be determined from tables 1 through 5 in chapter 9 of the *NEC*[®].

CONTROL SYMBOLS

In figures 7-11 and 7-12, you see the electrical symbols that conform to the standards established by the National Electrical Manufacturer's Association (NEMA). Where NEMA standards do not exist, American Standards Association (ASA) standards are used; however, not all manufacturers use these established symbols. In spite of the lack of standardization, knowledge of the symbols presented in this unit will give you a firm basis for interpreting variations found in the field.

PUSH BUTTONS							PILOT LIGHTS					
MOMENTARY CONTACT					MAINTAINED CONTACT		INDICATE COLOR BY LETTER					
SINGLE CIRCUIT		DOUBLE CIRCUIT		MUSHROOM HEAD	WOBBLE STICK	ILLUMINATED	TWO SINGLE CRT	ONE DOUBLE CRT				
N.O.	N.C.	N.O.	N.C.									
CONTACTS				COILS				OVERLOAD RELAYS		INDUCTORS		
INSTANT OPERATING				TIMED CONTACTS - CONTACT ACTION RETARDED WHEN COIL IS				SHUNT	SERIES	THERMAL	MAGNETIC	IRON CORE
WITH BLOWOUT		WITHOUT BLOWOUT		ENERGIZED		DE-ENERGIZED						
N.O.	N.C.	N.O.	N.C.	N.O.	N.C.	N.O.	N.C.					

SPST, N.O.		SPST, N.C.		SPDT		TERMS
SINGLE BREAK	DOUBLE BREAK	SINGLE BREAK	DOUBLE BREAK	SINGLE BREAK	DOUBLE BREAK	
						SPST - SINGLE POLE SINGLE THROW SPDT - SINGLE POLE DOUBLE THROW DPST - DOUBLE POLE SINGLE THROW DPDT - DOUBLE POLE DOUBLE THROW N.O. - NORMALLY OPEN N.C. - NORMALLY CLOSED
DPST, 2 N.O.		DPST, 2 N.C.		DPDT		
SINGLE BREAK	DOUBLE BREAK	SINGLE BREAK	DOUBLE BREAK	SINGLE BREAK	DOUBLE BREAK	

PRESSURE & VACUUM SWITCHES		LIQUID LEVEL SWITCH		TEMPERATURE ACTUATED SWITCH		FLOW SWITCH (AIR, WATER, ETC.)																		
N.O.	N.C.	N.O.	N.C.	N.O.	N.C.	N.O.	N.C.																	
FUSE	STANDARD DUTY SELECTOR		HEAVY DUTY SELECTOR																					
	2 POSITION		2 POSITION		3 POSITION		2 POS SEL PUSH BUTTON																	
	3 POSITION		1-CONTACT CLOSED		1-CONTACT CLOSED		<table border="1"> <thead> <tr> <th colspan="2">SELECTOR POSITION</th> <th colspan="2">BUTTON</th> </tr> <tr> <th>A</th> <th>B</th> <th>FREE</th> <th>DEPRESSED</th> </tr> </thead> <tbody> <tr> <td>1-2</td> <td>1</td> <td></td> <td></td> </tr> <tr> <td>1-2</td> <td>1</td> <td></td> <td></td> </tr> </tbody> </table>		SELECTOR POSITION		BUTTON		A	B	FREE	DEPRESSED	1-2	1			1-2	1		
SELECTOR POSITION		BUTTON																						
A	B	FREE	DEPRESSED																					
1-2	1																							
1-2	1																							

CEI#0711

Figure 7-11.—Standard wiring diagram symbols.

SWITCHES								
DISCONNECT	CIRCUIT INTERRUPTER	CIRCUIT BREAKER W/THERMAL O. L.	CIRCUIT BREAKER W/MAGNETIC O. L.	CIRCUIT BREAKER W/THERMAL AND MAGNETIC O. L.	LIMIT SWITCHES		FOOT SWITCHES	
					NORMALLY OPEN	NORMALLY CLOSED	N. O.	N. C.
					HELD CLOSED	HELD OPEN		

WIRING				CONNECTIONS		RESISTORS			CAPACITORS	
NOT CONNECTED	CONNECTED	POWER	CONTROL	WIRING TERMINAL	MECHANICAL	FIXED	ADJ BY FIXED TAPS	RHEOSTAT POT OR ADJ TAP	FIXED	ADJ
				GROUND	MECHANICAL INTERLOCK	HEATING ELEMENT				
SPEED (PLUGGING)		ANTI-PLUG	BELL	BUZZER	HORN SIREN, ETC.	METER	METER SHUNT	HALF WAVE RECTIFIER	FULL WAVE RECTIFIER	BATTERY

TRANSFORMERS					A.C. MOTORS			D.C. MOTORS			
AUTO	IRON CORE	AIR CORE	CURRENT	DUAL VOLTAGE	SINGLE PHASE	3 PHASE SQUIRREL CAGE	WOUND ROTOR	ARMATURE	SHUNT FIELD	SERIES FIELD	COMM OR COMPENS FIELD
									(SHOW 4 LOOPS)	(SHOW 3 LOOPS)	(SHOW 2 LOOPS)

CEI0712

Figure 7-12.—Standard wiring diagram symbol—Continued.

The control-circuit line diagram of figure 7-13 shows the symbol of each device used in the circuit and indicates its function. The push-button station wiring diagram on the right of figure 7-13 represents the physical control station and shows the relative position of each device, the internal wiring, and the connections with the motor starter.

Control and Power Connections

The correct connections and component locations for line and wiring diagrams are shown in table 7-1. Compare the information given in the table with actual

line diagrams to develop the ability to interpret the table quickly and use it correctly; for example, refer to figure 7-14 and the three-phase column of table 7-1. Note that the control circuit switching is connected to line 1 (L1) and the contactor coil is connected to line 2 (L2)

Control Wiring

Control wiring can be very confusing. A single operation of an electrical circuit is usually not complicated; however, a sequence of operations, one depending on the other, in a complex circuit can be

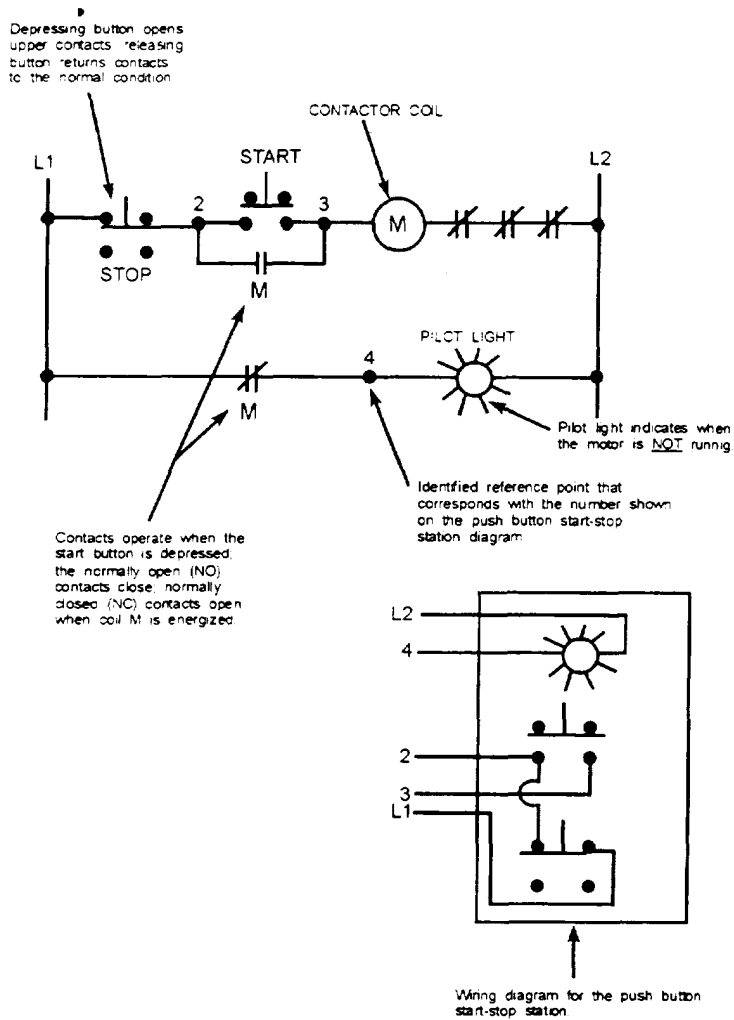

CEI0713

Figure 7-13.—Control circuit components.

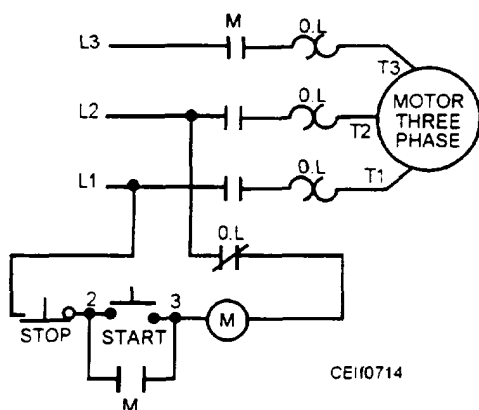

Figure 7-14.—Three-phase motor controller diagram.

difficult to understand. As you already know, most electrical circuits are represented as a wiring diagram or a line diagram. Work through the examples given throughout this chapter. This practice will improve

your skills in reading and understanding electrical diagrams. If the diagrams are too complex, break them down to a more elementary diagram. These diagrams are your key to understanding how a machine operates and how to repair it when it breaks.

TWO-WIRE CONTROL.—Two-wire control provides no-voltage release or low-voltage release. Two-wire control of a starter means that the starter drops out when there is a voltage failure and picks up as soon as the voltage returns. In figure 7-15, the pilot device is unaffected by the loss of voltage. Its contact remains closed, ready to carry current as soon as line voltage returns to normal.

The phrases **no-voltage** release and **two-wire control** should indicate to you that an automatic pilot device, such as a limit switch or a float switch, opens and closes the control circuit through a single contact.

Table 7-1.—Power and Control Connections for Across-the-Line Motor Controllers/Starters

	DIRECT CURRENT	SINGLE PHASE	THREE PHASE
Line markings for.	L1 & L2	L1 & L2	L1, L2, & L3
Overload relay heaters in	L1	L1	T1, T2, & T3
Contactors coil connected to	L2	L2	L2
Overload relay contacts in	L2	L2	L2
Control circuits connected to	L1 & L2	L1 & L2	L1 & L2
Control circuit switching connected to.	L1	L1	L1
Reversing interchange lines.	N/A	N/A	L1 & L3
Requiring grounding.	L1 is always ungrounded	L1 is always ungrounded	L2

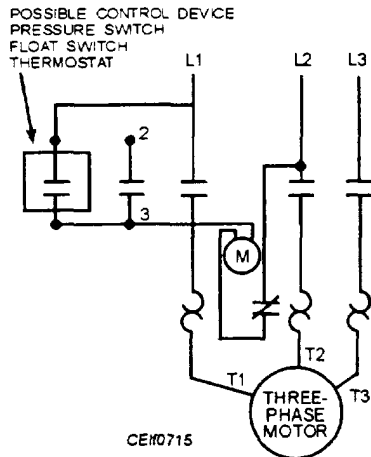

Figure 7-15.—Two-wire control circuit.

THREE-WIRE CONTROL.—The three-wire control involves the use of a maintaining circuit. This method eliminates the need for the operator to press continuously on the push button to keep the coil energized. Refer to the elementary control circuit diagram in figure 7-16. When the START button is pressed, coil M is energized across L1 and L2. This action closes contact M to place a shunt circuit around terminals 2 and 3. the START button. A parallel circuit is formed with one circuit through push-button terminals 2 and 3 and one circuit through contact M. As a result, current will flow through the M coil. If pressure is removed from the START button, terminals 2 and 3 open. The other circuit through contacts M remains closed, supplying current to coil M and

maintaining a started-closed position. Such a circuit is called a maintaining circuit: a sealing circuit, or a holding circuit.

The phrases no-voltage protection and three-wire control should indicate to the electrician that the most common means of providing this type of control is a start-stop push-button station.

The main distinction between the two types of control is that in no-voltage release (two-wire control), the coil circuit is maintained through the pilot-switch contacts; in no-voltage protection (three-wire control), the circuit is maintained through a stop contact on the push-button station and an auxiliary (maintaining) contact on the starter.

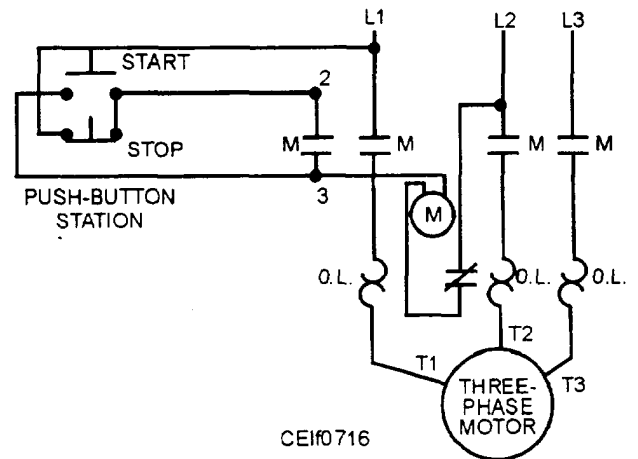

Figure 7-16.—Three-wire control circuit.

LOW-VOLTAGE CONTROL.—Sometimes it is desirable to operate push buttons or other control devices at some voltage lower than the motor voltage. In the control system for such a case, a separate source, such as an isolating transformer or an independent voltage supply, provides the power to the control circuit. This independent voltage is separate from the main power supply for the motor.

One form of separate control is shown in figure 7-17. When the thermostat calls for cooling and the high-low pressure control is activated, the compressor motor starter coil M is energized through the step-down isolating transformer. When coil M is energized, power contacts in the 240-volt circuit close to start the refrigeration compressor motor. Since the control circuit is separated from the power circuit by the isolating control transformer, there is no electrical connection between the two circuits. For this reason, the wire jumper attached to L2 on a starter should be removed for different voltages; however, the overload relay control contact must be included in the separate control wiring.

TROUBLESHOOTING AND TESTING CONTROLLERS

In this section it is assumed that the motor and fuse are in good condition. To make certain that the motor is not at fault, connect a voltmeter at the motor terminals and determine whether voltage is available when the contacts of the controller are closed. If there is no voltage, the trouble probably lies in the controller.

TROUBLESHOOTING

By using a snap-around type of voltmeter-ohmmeter or individual instruments, you can conduct many of the tests needed to determine opens, shorts, grounds, and continuity in just a short time. You can test malfunctioning circuits for shorted coils; open coils; grounded coils; open resistances; shorted resistances; low voltages; high voltages; excessive amperes; broken, loose, or dirty connections; and many other problems with comparative ease. This testing is true of all motors, as well as starters.

You should follow a systematic procedure when troubleshooting controls.

WARNING

You must exercise extreme caution when testing live components. Always use the one-hand rule to avoid completing the circuit between the live component and a metal surface. Always have a second person standing by when working on energized equipment and ensure the person is qualified in CPR. When working on anything that should have the power off, always shut the power off **yourself**. Most disconnects have allowances for a padlock to be used to keep the power from being turned back on. This safety precaution is called "LOCKOUT." The NAVOSH Manual, OPNAVINST 5 100.23, provides guidance on the Lockout/Tag out program at shore activities according to OSHA regulations. It is extremely important to take this precaution. Controls with voltage over 240 volts should never be energized when you are troubleshooting.

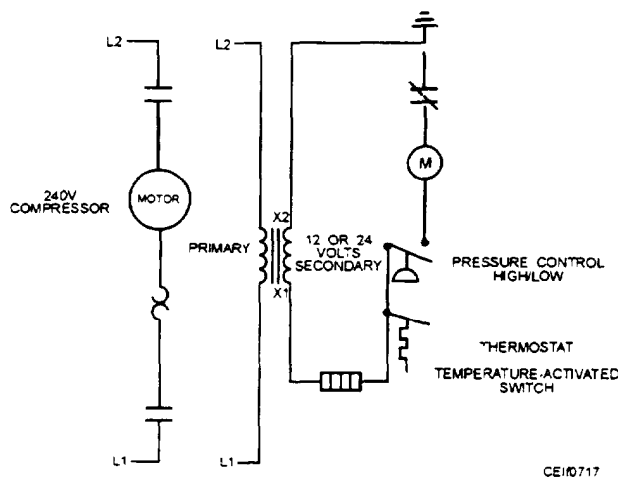

Figure 7-17.—Low-voltage control circuit.

Because there are so many different kinds and makes of controllers, we will outline a general procedure for locating the source of trouble.

1. If the motor does not start when the main contacts close, the trouble may be as follows:

- a. Open overload heater coil or poor connection.
- b. Main contacts not making contact. It is not unusual for one or more contacts to wear to the degree that they will not make when closed. This fault will also occur if the contacts become dirty, gritty, or burned.
- c. Broken, loose, or dirty terminal connection.
- d. Loose or broken pigtail connection.
- e. Open resistance units or open autotransformer.
- f. Obstruction of the magnet core, preventing the contacts from closing.
- g. Mechanical trouble, such as mechanical interlocks, gummy pivots, and poor spring tension.

2. If the contacts do not close when the START button is pressed, the trouble may be as follows:

- a. Open holding coil. This can be tested by connecting a voltmeter across the coil terminals when the START button is pressed. If there is voltage when the START button is pressed but the coil does not become energized, the coil is defective.
- b. Dirty START button contacts or poor contact.
- c. Open or dirty STOP button contacts. If more than one station is connected to the same controller, each station should be checked. If FORWARD-REVERSE stations are used and they are interlocked, check all contacts.
- d. Loose or open terminal connections.
- e. Open overload-relay contacts.
- f. Low voltage.
- g. Shorted coil.
- h. Mechanical trouble.

3. If the contacts open when the START button is pressed, the trouble may be as follows:

- a. Contacts that do not close completely or are dirty, pitted, or loose.

- b. Wrong connection of station to the controller.

4. If a fuse blows when the START button is pressed, the trouble may be as follows:

- a. Grounded circuits.
- b. Shorted coil.
- c. Shorted contacts.

5. If the magnet is noisy in operation, the trouble may be as follows:

- a. Broken shaded pole causing chattering.
- b. Dirty core face.

6. If the magnet coil is burned or shorted, the trouble may be as follows:

- a. . Overvoltage.
- b. Excessive current due to a large magnetic gap caused by dirt, grit, or mechanical trouble.
- c. Too frequent operation.

TESTING COMPONENT CIRCUITS

The example used here is a control that is operated by a remote switch, such as a float switch. It is assumed that the device being controlled (a three-phase motor) is in good working order but is not receiving power. Figure 7-18 shows such a circuit.

The first thing you should check is the line voltage. To do this check, remove the cover of the control box and test each line with a voltmeter. You should take the volt readings between L1 and L2, L2 and L3, and then between L3 and L1. If full voltage is found, you should visually check the power circuit for loose connections. These terminals include L1, L2, L3, T1, T2, and T3. Look for signs of heating at these connections. When a connection becomes loose, the terminal becomes very hot; and the screw, wire, and terminal become discolored or charred. Check all terminals and tighten them if necessary. **You should only do this checking and tightening with the power OFF.**

Next, check the control circuitry within the controller. Do this check by looking at the control circuit shown in figure 7-18. The external controls, the magnetic holding coil, and the normally closed overload contacts are always located between line 1 and line 2. Unless the control has been altered, line 3 is not part of the control circuit. Check also that the externally located controlling switches, such as the

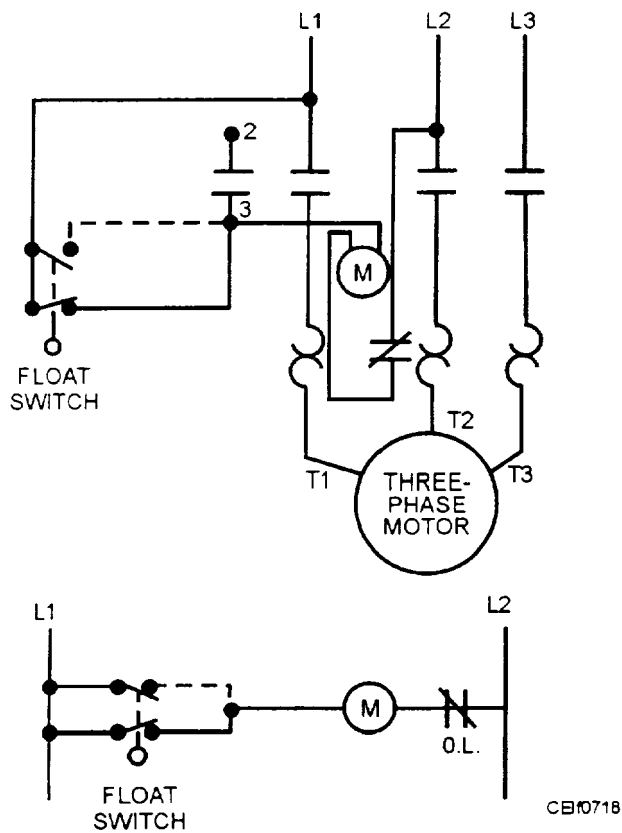

Figure 7-18.—Three-phase starter controlled by a float switch.

push button, the float, the pressure, or the limit switches, are connected between line 1 and the holding coil. The normally closed overload contacts are always located between the holding coil and line 2. A wiring diagram usually can be found in the cover of the controller. Now it has been established that the motor and line voltage are in working order. This checking has narrowed the problem to the control circuit and the chance that some components are open.

You can locate opens in the control circuit with a voltmeter. Connect one lead of the voltmeter to line 1, and touch the other lead to first one terminal or the holding coil and then the other terminal. There should be the same voltage reading that is read between line 1 and line 2. If the control circuit voltage is supplied with a transformer, the voltage read should be that of the transformer output. If there is no voltage on either side of the holding coil, the overload contacts are open. Pushing the RESET button should close the overload contacts. If they do not close after they have had time to cool, they may be defective. In this case, they should be replaced.

If there is a voltage on one terminal of the holding coil but not the other, the coil is open. You must then

replace the coil. If there is a voltage on both terminals of the holding coil, the coil and the overload contacts can be assumed to be in working order. To double-check these components, short out line 1 and the terminal marked 3 with a piece of wire. This action will bypass the external control, and then the holding coil should close the contacts. You can use a current-limiting resistor in place of a wire. If the control functions, the problem is in the external controlling device.

Solid-state controllers have very complicated circuitry; thus, troubleshooting these units requires a good background in electronics and electric motors. These controllers have repair instructions with them as well as a list of parts that should be stocked for repair purposes. Repairs consist of replacing boards or modules that plug into the circuitry.

COMBINATION STARTERS

A combination starter consists of a magnetic starter and disconnect switch mounted in the same enclosure. These starters are supplied with either a fused disconnect switch or a circuit breaker. The fuses (or circuit breaker) provide short-circuit protection by disconnecting the line. A combination starter and circuit breaker will prevent single phasing by simultaneously opening all lines when a fault occurs in any one phase. This type of starter can be quickly reset after the fault has been cleared. Figure 7-19 shows a fused combination starter. Figure 7-20 shows a combination starter and a thermal-magnetic circuit breaker.

PUSH-BUTTON-STATION CONNECTIONS

We will now show you a number of control circuits with various combinations of push-button stations. All of these diagrams use one type of magnetic switch, but others can be used. Figure 7-21 shows a magnetic switch that is operated from any of three stations. Figure 7-22 shows a straight-line diagram of the control circuit of three start-stop stations. Figure 7-23 shows the control circuit of two start-stop stations. In these diagrams, the START buttons are connected in parallel, and the STOP buttons are connected in series. These button connections must be done regardless of the number of stations. Note that the maintaining contact is always connected across the START button. All STOP buttons are connected in series with one another and in series with the holding coil, so the motor can be stopped from any position in case of emergency.

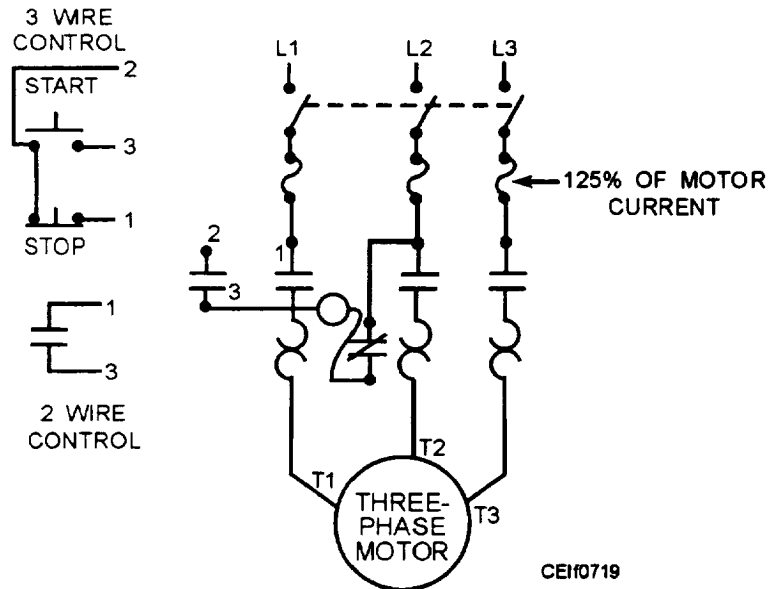

Figure 7-19.—Combination starter with a disconnect switch.

MOTOR MAINTENANCE

Modern methods of design and construction have made the electric motor one of the least complicated and most dependable forms of machinery in existence and thereby have made the matter of its maintenance one of comparative simplicity. This statement, however, should not be taken to mean that proper maintenance is not important; on the contrary, it must be given careful consideration if the best performance and longest life are to be expected from the motor. The two major features, from the standpoint of their effect upon the general performance of the motor, are those of proper lubrication and the care given to insulation. Lubrication and insulation protect the most vital, and probably the most vulnerable, parts of the machine.

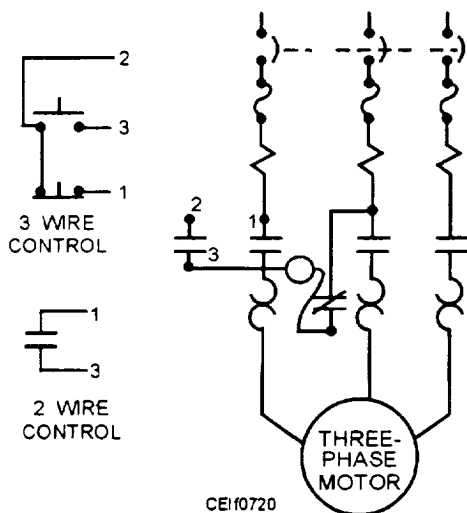

Figure 7-20.—Combination starter with a thermal-magnetic circuit breaker.

START-STOP STATION WITH A PILOT LIGHT

Sometimes it is advisable to have a pilot light on the push-button station to indicate whether the motor is running. The lamp usually is mounted on the station and is connected across the holding coil. Such a connection is shown in figures 7-24 and 7-25. Figure 7-26 shows a control circuit with the pilot light on when the motor is stopped. Normally closed contacts are needed on this starter. When the motor is running, these contacts are open. Contacts are closed when the motor is stopped, and the pilot light goes on.

LUBRICATION

The designs of bearings and bearing housings of motors have been remarkably improved. However, this advance in design can cause problems. The bearings of modern motors, whether sleeve, ball, or roller, require infrequent attention. In the case of older designs with housings less tight than on modern machines, oiling and greasing are done frequently. The perpetuation of this habit causes the oiling and greasing of new motors to be overdone. The result is that oil or grease is copiously and frequently applied to the out-side, as well as the inside, of bearing housings. Some excess lubricant is carried into the machine and lodges on the windings where it catches dirt and thereby hastens the ultimate failure of the insulation.

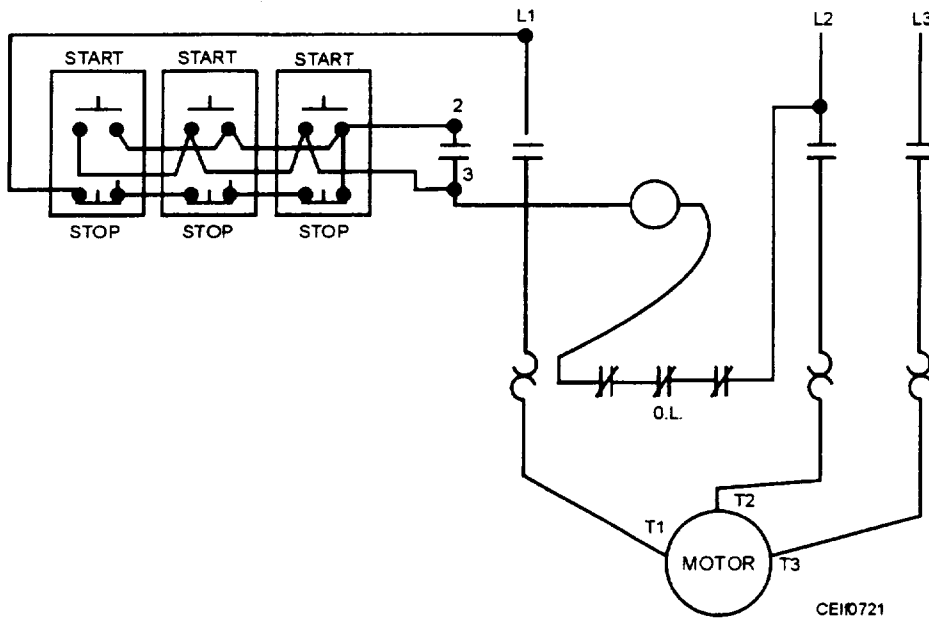

Figure 7-21.—Magnetic switch controlled by three start-stop stations.

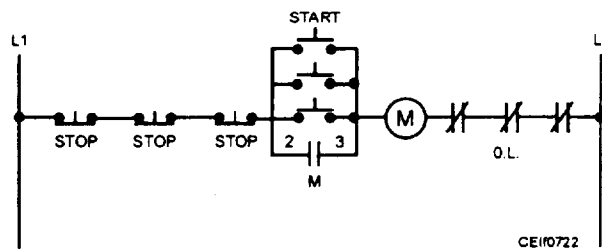

Figure 7-22.—Control circuit for three start-stop stations.

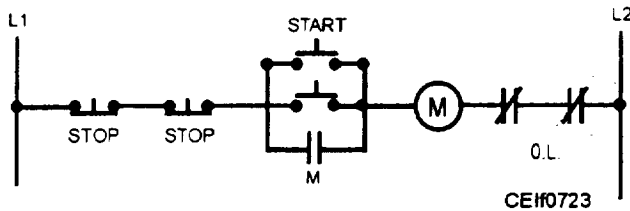

Figure 7-23.—Control circuit for two start-stop stations.

Greasing Ball Bearings

Only a high grade of grease with the following general characteristics should be used for ball-bearing lubrication:

1. Consistency, a little stiffer than that of petroleum jelly, maintained over the operating temperature range
2. Melting point preferably over 150°C
3. Freedom from separation of oil and soap under operating and storage conditions

4. Freedom from abrasive matter, acid, and alkali

In greasing a motor, you must take care not to add too much grease. Overgreasing will cause too high an operating temperature with resulting expansion and leaking of the grease, especially with large bearings operated at slow speeds.

CAUTION

Always review the Material Safety Data Sheet (MSDS) for greases, oils, lubricants, and other hazardous materials before use. Avoid prolonged skin contact with lubricants. Dispose of waste materials in an environmentally responsible manner.

Pressure-Relief Systems

The following procedures are recommended for greasing ball-bearing motors equipped with a pressure-relief greasing system.

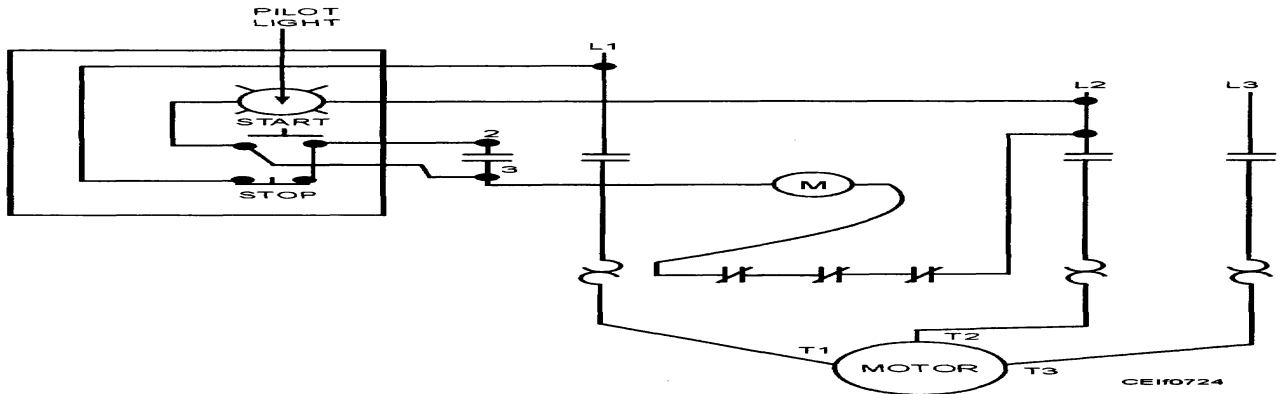

Figure 7-24.—Push-button station with a pilot light.

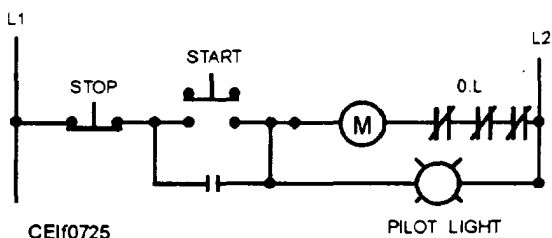

Figure 7-25.—Control circuit with a pilot light.

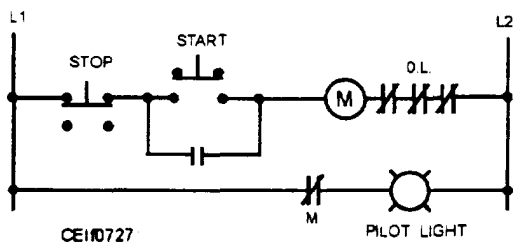

Figure 7-26.—Pilot light indicates when motor is not running.

Before pumping grease into the grease fitting, wipe it clean to prevent the grease from carrying dirt into the fitting and bearing housing. Always remove the relief plug from the bottom of the bearing before using the grease gun. This action prevents applying excessive pressure, which could rupture the bearing seals inside the bearing housing.

With a clean screwdriver or similar tool, free the relief hole of any hardened grease so that any excess grease will run freely from the bearing. With the motor running, add grease with a hand-operated pressure gun until it begins to flow from the relief hole. This procedure tends to purge the housing of old grease.

WARNING

It might prove dangerous to lubricate the motor while it is running; follow the procedures with the motor at a standstill.

After adding the grease, allow the motor to run long enough to permit the rotating parts of the bearing to expel all excess grease from the housing. This very important step prevents overgreasing of the bearing. Stop the motor and tightly replace the relief plug with a wrench.

Motors that are not equipped with the pressure-gun fitting and the relief plug on the bearing housing cannot be greased by the procedures described. Under average operating conditions, the factory-packed grease in the bearing housings of these motors is sufficient to last approximately 1 year. When the first year of service has elapsed and once a year thereafter (or more often if conditions warrant), you should

remove the old grease and lubricate the bearings with new grease. To do this, disassemble the bearing housings and clean the inside of the housings and housing plates or caps and the bearings with a suitable solvent. When you have thoroughly cleansed them of old grease, reassemble all parts except the outer plates or caps. Apply new grease, either by hand or from a tube, over and between the balls. The amount of grease you should use varies with the type and frame size of the particular motor. You should consult the instruction sheet that accompanied the motor for this information.

You should add enough grease to fill the bearing housing one-third to one-half full. Do not use more than the amount specified. After reassembling the motor, you should refill any V-grooves that are found in the housing lip with grease (preferably a fibrous, high-temperature-sealing grease) that will act as an additional protective seal against the entrance of dirt or foreign particles.

Roller Bearings

The technique for greasing motors equipped with roller bearings is quite similar to that used for ball bearings. However, you should follow specific instructions for the individual design because more frequent greasing or slight changes in technique may sometimes be necessary.

Sleeve Bearings

With the motor stopped, you periodically should check the oil level in the sleeve-bearing housings. If the motor is equipped with an oil-filler gauge, the gauge should be approximately three-quarters full at all times.

If the oil is dirty, drain it off by removing the drain plug, which is usually located in the bottom or side of the bearing housing. Then flush the bearing with clean oil until the outcoming oil is clean.

Fractional-Horsepower Motors

In fractional-horsepower motors, there may be no means of checking the oil level, as all the oil may be held in the waste packing. In such cases, a good general rule for normal motor service is to add 30 to 70 drops of oil at the end of the first year and to reoil at the end of each subsequent 1,000 hours of motor operation.

Most fractional-horsepower motors built today require lubrication once a year. Small fan and agitator motors often require more frequent lubrication with 3-month intervals between oilings.

MOTOR STORAGE

Motors should be stored in a dry, clean place until ready for installation. Heat should be supplied, especially for larger high-voltage machines, to protect them against alternate freezing and thawing. This advice is equally applicable to spare coils.

Motors that have been in transit in a moist atmosphere or have been idle for an extended period without heat to prevent the accumulation of moisture should be dried out thoroughly before being placed in service. Machines also may become wet by accident, or they may sweat as a result of a difference between their temperature and that of the surrounding air. This condition is harmful particularly in the case of large or important motors, and should be prevented, by keeping them slightly warm at all times.

You can pass current at a low voltage through the windings, use electric heaters, or even use steam pipes for protective purposes. During extended idle periods, you can stretch tarpaulins over the motor and place a small heater inside to maintain the proper temperature.

If a motor should become wet from any cause, you should dry it out thoroughly before operating it again. The most effective method is to pass current through the windings, using a voltage low enough to be safe for the winding in its moist condition.

You can apply heat externally by placing heating units around or in the machine and cover the machine with canvas or some other covering, and then leave a vent at the top to permit the escape of moisture. You can use small fans to help circulation. You should not allow the temperature of the windings to exceed 100°C for Class A insulated motors.

PERIODIC INSPECTION

A systematic and periodic inspection of motors is necessary to ensure best operation. Of course, some machines are installed where conditions are ideal; and dust, dirt, and moisture are not present to an appreciable degree. Most motors, however, are located where some sort of dirt accumulates in the windings, lowering the insulation resistance and cutting down creepage distance. Dusts are highly abrasive and actually cut the insulation while being carried by ventilating air. Fine cast-iron dust quickly penetrates most insulating materials; hence, you can see why motors should be cleaned periodically. If conditions are extremely severe, open motors might require a certain amount of cleaning each day. For less severe conditions, weekly inspection and partial cleaning are

desirable. Most machines require a complete overhauling and thorough cleaning out once a year.

BRUSH INSPECTION

Essential for satisfactory operation of brushes is free movement of the brushes in their holders. Uniform brush pressure is necessary to assure equal current distribution. Adjustment of brush holders should be set so that the face of the holder is approximately one eighth of an inch up from the commutator; any distance greater than this will cause brushes to wedge, resulting in chattering and excessive sparking.

Check the brushes to make sure that they will not wear down too far before the next inspection. Keep an extra set of brushes available so that replacements can be made when needed. Sand in new brushes, and run the motor without a load to seat the brushes.

Make sure that each brush surface in contact with the commutator has the polished finish that indicates good contact and that the polish covers all contact surfaces of the brush. Check the freedom of motion of each brush in the brush holder. When replacing a brush, be sure to put it in the same brush holder and in its original position. It will be easier for you to replace the brush properly if you scratch a mark on one side of the brush before you remove it.

Check the springs that hold the brushes against the commutator. Improper spring pressure may lead to commutator wear and excessive sparking. Excessive heating may have annealed the springs, in which case you should replace them and correct the cause of overheating.

COMMUTATOR INSPECTION

Inspect the commutator for color and condition. The part where the brushes ride should be clean and smooth and should be a polished brown color. A bluish color indicates overheating of the commutator.

You should remove any roughness on the commutator by sandpapering or stoning. Never use an emery cloth or an emery stone. For this operation, run the motor without load. If you use sandpaper, wrap it partly around a wooden block. The stone is essentially a piece of grindstone, known to the trade as a commutator stone. With the motor running without load, press the stone or sandpaper against the commutator with moderate pressure and move it back and forth across the commutator surface. If the armature is very rough, it should be taken out and the commutator turned down in a lathe.

WARNING

Use care not to come into contact with moving parts.

RECORDS

The electrical shop should have a record card for every motor. As a minimum, the information on the card should include inspections, repair work, age, and replacement stock number.

CLEANING

About once a year or more often if conditions warrant, motors should be cleaned thoroughly. Smaller motors, the windings of which are not easily accessible, should be taken apart.

First, remove the heavy dirt and grease with a heavy, stiff brush; wooden or fiber scrapers; and cloths. You can use rifle-cleaning bristle brushes in the air ducts. You can blow-dry dust and dirt off, using dry-compressed air at a moderate pressure, perhaps 25 to 50-psi pressure at the point of application, taking care to blow the dirt out and away from the windings. If the dirt and dust are metallic, conducting, or abrasive, using air pressure is not as satisfactory as using a suction system.

CAUTION

When cleaning motors with compressed air, wear safety goggles and hearing protection. Dispose of lubricants and contaminated materials in an environmentally responsible manner.

You can easily remove grease, oil, and sticky dirt by applying cleaning liquids specifically designed for the purpose. These liquids evaporate quickly and, if not applied too generously, will not soak or injure the insulation. If you do use one of these liquids, be sure to follow the manufacturer's direction for use.

MOTOR START-UP

After new motors and controls are installed, they should be checked for operation under load for an initial period of at least 1 hour. During this time, the electrician can observe if any unusual noise or hot spots develop. The operating current must be checked against the nameplate ampere rating. This check requires skill in the proper connection, setting, and reading of a clamp-on ammeter. The nameplate ampere reading multiplied by the service factor (if any)

sets the limits of the steady current. This value should NOT be exceeded.

Check the power supply against the nameplate values; they should agree. Most motors will operate successfully with the line voltage within 10 percent (plus or minus) of the nameplate value or within 5 percent of the frequency (hertz). Most 220-volt motors can be used on 208-volt network systems but with slightly modified performance. Generally, 230-volt motors should not be used on 208-volt systems.

To reconnect a dual-voltage motor to a desired voltage, follow the instructions on the connection diagram on the nameplate.

Motor-starter-overload-relay heaters of the proper size must be installed. The motor will not run without them. Sizing information is found inside the control enclosure cover. The starting fuses should be checked in a similar manner. The selection of the correct fuse size must be according to the *NEC*® or local requirements.

If the motor has not been installed in a clean, well-ventilated place, clean the area. Good housekeeping, as well as direct accident and fire-prevention techniques, must be emphasized.

Check the motor mounts to be sure that they are secure and on a firm foundation. If necessary, add grout to secure the mounts.

Rotate the end shields to place grease fittings, plugs, or any openings in the best, or most accessible, location. Oil or grease the bearings, if necessary.

EQUIPMENT TROUBLESHOOTING

In troubleshooting motors, the first step is to shut down the machine and lock it out for repair or adjustment. The most valuable troubleshooting asset is your ability to apply common sense when analyzing a control operation. Also, experienced Construction Electricians learn to use sensory functions to diagnose and locate trouble.

- **LOOKING** may reveal contacts stuck and hung up, thereby creating open circuits.
- **LISTENING** may indicate loose parts, faulty bearings, excessive speed, and so forth.
- **SMELLING** may indicate burning insulation or a coil failure.
- **TOUCHING** may reveal excessive motor shaft play, vibration, or normal heat.

Using this seemingly oversimplified procedure to locate a problem may save you many hours of labor. Consider the length of time it would take to become thoroughly familiar with a complicated schematic diagram, compared with locating a few contacts that are stuck by merely **LOOKING**.

However, finding a problem in an installation is not usually this easy. An orderly, step-by-step approach is required. Circuit operation is separated into logical parts. Circuits and components are then divided into smaller parts to determine their functions, the relationships to one another, and the effect that they have on each other in the overall control system operation. Each step leads closer to the source of the difficulty, finally pinpointing the problem. This procedure may require the use of a voltage tester, ammeter, multimeter, jumper wires, and other tools.

Check the power supply to see if it is on and if it is correct. Test all protective devices. If a coil does not energize (fig. 7-27), connect a jumper wire from L1 to terminal 3 of the control circuit. By jumping across the contacts of the limit switch and push buttons, you have separated the circuit operation into logical parts. If the starter coil is now energized, the problem may be in the limit switch or **STOP** or **START** push buttons. You now can test smaller circuits and components by “jumping” around them individually. Test the limit switch, for example, then go to the control station, if necessary. By an orderly process of elimination accomplished by testing all possible fault areas, you can locate the problem accurately and efficiently.

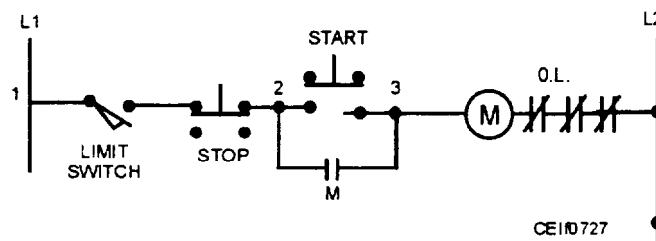

Figure 7-27.—Start-and-hold control circuit.

WARNING

Indiscriminate jumping, however, should not be practiced because of the danger of short circuits. For example, a jumper should never be placed across a power-consuming device, such as a contactor coil; voltage or ohmmeters testers are

used in this instance. If an ohm-meter is used to test a coil for continuity, the power must be OFF.

Table 7-2 is provided as an aid to servicing electric control equipment. Refer to the table to find the possible causes of a controller symptom.

Table 7-2.—Controller Troubleshooting Tips

Controller Symptoms	Possible Causes and Recommended Items to Investigate
Arcing and burning of contacts	Should handle very little current and have sealing circuit; misapplied
Bellows distorted (on thermally operated devices)	Mechanical binding; temperature allowed to pass control limits
Blowout coil overheats	Overcurrent; wrong size of coil; loose connections on stud or tip; tip heating; excess frequency
Breakage, distortion and wear	Overheating; mechanical abuse; severe vibration; shock
Breakdown (of static accessories)	High temperature; moisture; overcurrent; overvoltage; corrosive atmosphere; mechanical damage; overload; ac on dc capacitor; continuous voltage on intermittent types
Broken flexible shunt	Large number of operations; improper installation; extreme corrosive conditions; burned from arcing
Broken pole shader	Heavy slamming caused by overvoltage; weak tip pressure; wrong coil; mechanical overload; low frequency
Bulbs distorted (on thermally operated devices)	Liquid frozen in capillary tube
Burning and welding of control contacts and shunts	Shorts circuits on control circuits with too large protecting fuses; severe vibration; dirt; oxidation
Coil failure	Moisture; overvoltage; high ambient temperature; failure of magnet to seal in on pickup; too rapid duty cycle; metallic dust; corrosive atmosphere; chattering of magnet; wrong coil; holding resistor not cut in; intermittent coil energized continuously; mechanical failure; mechanical overload; mechanical underload; handling fluid above rated temperature
Contact opens prematurely	Dirt in air gap; shim too thick; too much spring and tip pressure; misalignment; not enough capacitance; not enough resistance
Contact takes longer than normal to open	Shim too thin; weak spring and tip pressure; gummy substance on magnet faces; too much capacitance; too much resistance
Contact-tip troubles	
a. Filing or dressing	Do not file silver tips; rough spots or discoloration will not. harm efficiency

Table 7-2.—Controller Troubleshooting Tips—Continued

b. Interrupting excessively high current	Check for grounds, shorts, or excessive motor currents
c. Excessive jogging	Install larger device rated for jogging service
d. Weak tip pressure	Replace contacts and springs; check carrier for damage
e. Dirt on surfaces	Clean contacts; reduce exposure
f. Short circuits or ground fault	Remove fault; be sure fuse/breaker size is correct
g. Loose connection	Clean then tighten
h. Sustained overload	Check for excessive motor current or install larger controller
Corrosion	Excess moisture; salt air; acid fumes
Excess wear or friction	Abrasive dust; high inertia load; excess temperature
Failure to break arc	Too much current; too much voltage (dc); misapplication; too much inductance
Failure to hold load	Worn parts; out of adjustment; misapplication; failure to use recommended substitute parts
Failure to make contact	Mechanical damage; dirt; corrosive; wear allowance gone
Failure to open or close	Low voltage; coil open; mechanical binding; mechanical overload; no voltage; wrong coil: shorted turns; excessive magnet gap: mechanical binding; gummy substance on magnet faces: air gap in magnet destroyed; contact tip welded; voltage not removed; corrosion; scale; dirt; operating above rated pressure; damaged motor
Failure to operate properly	Coils connected wrong; wrong coil; mechanical binding
Failure to release	Improper adjustment; coil not energized; mechanical binding: low voltage or current; coil open; shorted turns
Failure to reset overload relay	Mechanical binding; worn parts; dirt; broken mechanism; corrosion; worn parts; resetting to soon
Failure to set overload relay	Improper adjustment; mechanical binding; coil not de-energized; worn parts
Failure to time out (on motor operated relays)	Mechanical binding; worn parts; motor damaged; no voltage to motor; dirt
Failure to trip (during overload conditions)	Heater incorrectly sized; mechanical binding; relay previously damaged by short circuit current; dirt; corrosion; motor and relay in different ambient temperatures
Fast trip (on overload relays)	High temperature; wrong heaters
Flashover	Jogging; short circuits; handling too large motor; moisture; acid fumes; gases; dirt
Heating	Overcurrent; loose connection; spring clips loose or annealed; oxidation: corrosion

Table 7-2.—Controller Troubleshooting Tips—Continued

High trip	Mechanical binding; wrong or shorted coil; assembled wrong
Insulation failure	Moisture; acid fumes; overheating; accumulation of dirt on surfaces; voltage surges; short circuits; mechanical damage; overvoltage
Leaks and mechanical failure (on pneumatic and hydraulic controllers)	Corrosion; mechanical damage; excessive pressure; worn seat; solid matter in seat/strainer
Low trip	Wrong coil; assembled wrong
Mechanical wear or failure	Abrasive dust and dirt; misapplication; mechanical damage; excessive operating speed
Noisy magnet	Broken pole shader; magnet faces not true as result of wear or mounting strains; dirt on magnet faces; low voltage; mechanical overload; improper adjustment (too much pressure or incorrect lever ratio)
Overheating	Incorrect heat rating; running on starter resistor; overload; overvoltage; intermittent-rating device operating too long
Pitted, worn, or broken arc-chutes	Abnormal interrupting duty; excessive vibration or shock; moisture; improper assembly; rough handling
Premature blowing of protective fuses	Extra heating from outside; copper oxide on ferrules and clips; high ambient temperature
Resistor failure (on static accessories)	Overcurrent; moisture; corrosive atmospheres
Short contact life	Jogging; handling abnormal currents; lack of lubrication where recommended; abrasive dirt
Slow trip (of overload relays)	Mechanical binding; dirt; low temperature; wrong heaters
Sticking	Dirt; worn parts; improper adjustment; corrosion; mechanical binding
Too slow blowing (of fuse)	Wrong size fuse for application
Trips too low (on overload relay)	Wrong heater; relay in high ambient temperature (motor)
Various mechanical failures	Overvoltage; heavy slamming; chattering; abrasive dust; underload
Wear on magnet	Overvoltage; broken pole shader; wrong coil; underload; weak tip pressure; chattering; load out of alignment
Wear on segments or shoes (of a rheostat)	Abrasive dust; very heavy duty; no lubrication

CHAPTER 8

ALARM SYSTEMS

INTRODUCTION

Many buildings and complexes being constructed today are equipped with some type of intrusion detection and fire-alarm systems. You, as a Construction Electrician, will be challenged to install, troubleshoot, and maintain these systems. Numerous detection and fire-alarm systems are in existence today. In this chapter, we will discuss the function and operation of a typical detection system and various fire-alarm systems. When you are in charge of the installation or maintenance of either a detection or a fire-alarm system, you should acquire reference material, such as manufacturer's literature. If such material is unattainable, refer to *Maintenance of Fire Protection Systems*, NAVFAC MO-117, that provides an excellent description of several fire-alarm systems. *Commercial Intrusion Detection Systems (IDS)*, Design Manual 13.02, provides descriptions of various intrusion detection systems.

The purpose of any alarm system is either to protect life or property or to detect an intrusion. Alarm systems are set up to (1) give early warning so occupants may evacuate the building and (2) notify the fire department and/or security so they can react as soon as possible.

This chapter will increase your knowledge about security/fire-alarm system installation techniques, operations, and maintenance.

INSTALLATION TECHNIQUES

Before the installation of a security/fire-alarm system is started, a sketch of the building should be prepared or the original blueprints should be obtained. This sketch should be drawn to scale and should show the location of all windows and doors, chases, closets, and so forth. A simple riser diagram showing the various components, such as smoke and heat sensors, control panel, and alarm signals, should also appear on the sketch. When this is completed, the installer can begin the design of the security/fire-alarm system. As a Seabee, it is important to check all supporting documents in the manufacturer's manual before

installing a system. If you encounter a problem, contact the NAVFAC alarm systems coordinator.

TYPES OF FIRE-ALARM SYSTEMS

Building alarm systems may be local or local with base alarm system connections. They may be coded or noncoded and may operate either on line-voltage or low-voltage electric power. Their characteristics are described in the following paragraphs.

Coded Alarm Systems

A coded alarm system has audible or visual alarm signals with distinctive pulsing or coding to alert occupants to a fire condition and the location or type of device that originated the alarm. Coding the audible appliances may help personnel to distinguish the fire-alarm signal from other audible signals. Clear and early recognition of the signal should encourage a more orderly and disciplined evacuation of the building. A common characteristic of coded alarm systems, especially of selective coded and multiplex coded systems, is that the coded alarm identification provided by the audible alarm signals is not repeated continuously. Normally, after four complete repetitions of the coded signal, the coding process ends.

Noncoded Alarm Systems

A noncoded alarm system has one or more alarm-indicating appliances to alert the building occupants of a fire but does not tell the location or the type of device that has been activated (manual alarm or automatic protection equipment). The audible or visual alarm appliances operate continuously until they are turned off, until a predetermined time has passed, or until the system is restored to normal. The location or type of device originating the alarm condition can be determined by using an annunciator system. An annunciator is a visual-indicating device.

NATIONAL ELECTRICAL CODE REQUIREMENTS FOR SECURITY/ FIRE-ALARM SYSTEMS

Because of the potential fire and explosion hazards caused by the improper handling and installation of electrical wiring, certain rules in the selection of materials and quality of workmanship must be followed as well as precautions for safety. The *National Electrical Code*[®] (*NEC*[®]) was developed to standardize and simplify these rules and provide some reliable guide for electrical construction.

The *NEC*[®] is published (and frequently revised) by the National Fire Protection Association (NFPA), Batterymarch Park, Quincy, MA 02269. It contains specific rules and regulations intended to help in the practical safeguarding of persons and property from hazards arising from the use of electricity, including low voltage, used in the majority of security/fire-alarm systems.

Article 725 of the *NEC*[®] covers remote-control, signaling, and power-limited circuits that are not an integral part of a device or appliance. The *NEC*[®] (section 725-1) states:

The circuits described herein (Article 725) are characterized by usage and electrical power limitations that differentiate them from light and power circuits and, therefore, special consideration is given with regard to minimum wire sizes, derating factors, overcurrent protection, and conductor insulation requirements.

Personnel assigned to install security/fire-alarm systems should become familiar with Article 725 of the *NEC*[®] as well as Article 760, "Fire Protective Signaling Systems." This article covers the installation of wiring and equipment of fire-protective signaling systems operating at 600 volts or less.

Other *NEC*[®] articles of interest to security/fire-alarm installers include the following:

1. Section 300-21, "Spread of Fire or Products of Combustion."
2. Articles 500 through 516 and Article 517, Part G (dealing with installations in hazardous locations).
3. Article 110, "Requirements for Electrical Installations" and Article 300, "Wiring Methods."
4. Article 310, "Conductors for General Wiring."

5. Fire-protective signaling circuits and equipment will be grounded according to Article 250, except for dc-power limited fire-protective signaling circuits that have a maximum current of 0.03 amperes.

6. The power supply of nonpower-limited fire-protective signaling circuits will comply with chapters 1 through 4 and the output voltage will not be more than 600 volts, nominal.

7. Conductors of No. 18 and No. 16 sizes will be permitted to be used provided they, supply loads that do not exceed the ampacities given in table 402-5 and are installed in a raceway or a cable approved for the purpose. Conductors larger than No. 16 will not supply loads greater than the ampacities given in tables 310-16 through 310-19.

8. When only nonpower-limited fire-protective signaling circuits and Class 1 circuits are in a raceway, the number of conductors will be determined according to section 300-17. The derating factors given in Note 9 to tables 310-16 through 310-19 will apply if such conductors carry continuous loads.

9. Where power-supply conductors and fire-protective signaling circuit conductors are permitted in a raceway according to section 760-15, the number of conductors will be determined according to section 300-17. The derating factors given in Note 8 to tables 310-16 through 310-19 will apply as follows:

a. For all conductors when the fire-protective signaling circuit conductors carry continuous loads and the total number of conductors is more than three.

b. For the power-supply conductors only when the fire-protective signaling circuit conductors do not carry continuous loads and the number of power-supply conductors is more than three.

10. When fire-protective signaling circuit conductors are installed in cable trays, comply with sections 318-8 through 318-10.

UNDERSTANDING BASIC INSTALLATION OF SECURITY/ FIRE-ALARM SYSTEMS

The installation of a protective security/fire-alarm circuit should always start at the protective-circuit energy source, as if it were an end-of-line battery-a battery, remote from the control panel-even though it may actually be a power supply installed in the panel. A pair of wires is run from this power source to the first contact location, but just the positive wire is cut and

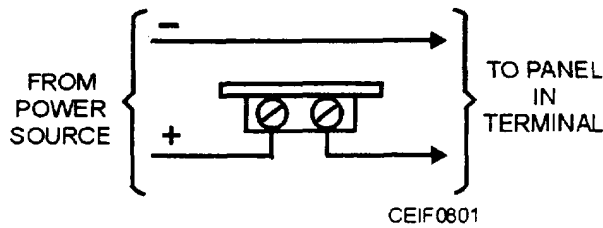

Figure 8-1.—Contacts are connected into the positive wire only. Break positive wire only at door contacts.

connected to the two contact terminals, as shown in figure 8-1. The neutral or common wire is not cut but continues on in parallel with the positive or “hot” wire. The pair is then run on to the next contact—a door, window, or sensor—and again only the hot wire is connected to the contacts. This procedure is repeated until all contacts are wired in series, and then the pair of wires is run from the last contact device on the system to the protective-circuit terminals in the panel. Although the markings will vary from manufacturer to manufacturer, the terminals for the starting connections will read something like LOOP POWER OUT, while the terminating terminals will read IN, or a similar term.

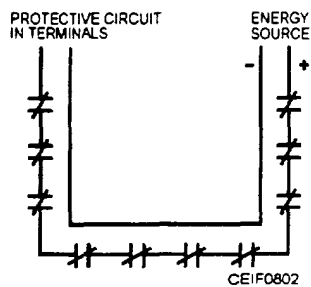

Figure 8-2.—Negative conductor is run with a positive conductor to all contacts, even though the system would operate with just a single-wire, positive-leg wire run from contact to contact.

A simple circuit of the wiring connections just described is shown in figure 8-2. Obviously, the system would operate with just a single-wire, positive-leg circuit run from contact to contact, with the negative power-supply terminal connected directly to the negative protective-circuit terminal within the cabinet. However, manufacturers discourage this practice since troubleshooting a single-wire circuit can be extremely time consuming, and the single wire is more vulnerable to defeat by an intruder with no trouble symptoms occurring to warn the user of the loss of protection.

An exit/entry delay relay is sometimes used on security systems so that authorized personnel may exit and enter (using their door keys) without activating the alarm. However, a shunt switch is more often preferred (fig. 8-3). The purpose of the shunt lock is to enable an authorized person with a key to shunt out the contacts on the door used for exit/entry, allowing him or her to enter or leave the premises without causing an alarm when the alarm system is turned on. The shunt lock does extend outside the protected premises; however: it is a potential weak link in the system. Following the two procedures suggested below makes defeat of the shunt lock much more difficult:

1. Install the shunt lock at the door that is most brightly illuminated and most readily visible to passersby.
2. Wire the shunt lock switch to the magnetic contact terminals, as shown in figure 8-4. This arrangement traps the lock so that any attempt to pull it out to gain access to its terminals will break the positive side of the protective circuit and cause an alarm to sound.

Contacts used to signal the opening of doors, windows, gates, drawers, and so forth are usually mounted on the frame of the door or window, while

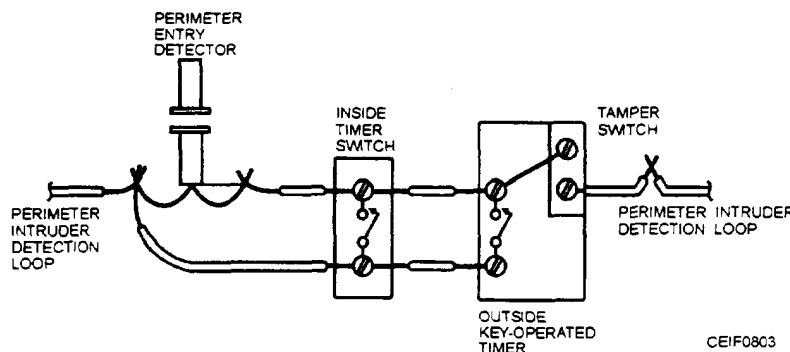

Figure 8-3.—Typical shunt switch circuit.

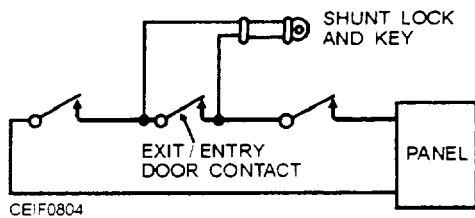

Figure 8-4.—Wire the shunt lock switch to the magnetic contacts as shown.

the magnet unit is mounted on the door or window (moving part) itself. The two units should be positioned so that the magnet is close to and parallel with the switch when the door or window is closed. This keeps the shunt lock actuated, but opening the door or window moves the magnet away and releases the switch mechanism.

As long as the faces of the switch and magnet are parallel and in close proximity when the door or window is closed, they may be oriented side-to-side, top-to-top, or top-to-side. Mounting spacers may be used under the units if necessary to improve their alignment and proximity.

Terminal covers are available for most makes of door contacts to give the installation a more finished look and also to protect the terminal connections against tampering.

The wiring of any alarm system is installed like any other type of low-voltage signal system; that is, one must locate the outlets, furnish a power supply, and finally interconnect the components with the proper size and type wire.

ALARM SYSTEMS INSTALLED IN EXISTING BUILDINGS

Many changes and advances in developing complete security/alarm systems for building operation and protection have taken place in the past few years. Numerous existing buildings are currently having security and fire-alarm systems installed either to replace their obsolete systems or to provide protection they never had.

The materials used for installing a complete alarm system in an existing building are essentially the same as those used in new structures. However, the methods used to install the equipment and related wiring can vary tremendously and require a great deal of skill and ingenuity. Each structure is unique.

When concealed wiring is to be installed in a finished existing building, the installation must be planned so that the Least amount of cutting and

patching is necessary. In most cases, this means giving special consideration to the routing of conductors. Unlike the wiring of a new building where the installer would try to conserve as much material as possible, the amount of material used (within reason) is secondary in existing buildings. The main objective in security/fire-equipment installations in existing buildings is to install the wiring in the least amount of time with the least amount of cutting and patching of the existing finishes of the building.

Before any actual work on an existing building is started, the contractor or the installers should make a complete survey of the existing conditions in the areas where the security system will be installed. If the majority of the work can be done in exposed areas (as in an unfinished basement or attic), the job will be relatively simple. On the other hand, if most of the wiring must be concealed in finished areas, there are many problems to be solved. The initial survey of the building should determine the following:

1. The best location for the alarm control panel.
2. The type of construction used for the exterior and interior walls, ceilings, floors, and so forth.
3. The location of any chases that may be used for routing the conductors and the location of closets, especially those located one above the other for possible use in fishing wires.
4. The material used for wall and ceiling finishes—plaster, drywall, paneling, and so forth.
5. Location of moldings, baseboards, and so forth, that may be removed to hide conductors.
6. Location of decorations or other parts of the building structure that cannot be disturbed.
7. Location of any abandoned electrical raceways that new alarm system wires might be fished into. Do not overlook similar possibilities. For example, an old abandoned gas line can be used to fish security-system wires in an old building.
8. The location of all doors and windows, coal chutes, and similar access areas to the inside of the building.

As indicated previously, the most difficult task in running wires in existing buildings is the installation of concealed wiring in finished areas with no unfinished areas or access to them. In cases like these, the work is usually performed in one of two ways. First by deliberately cutting the finished work so that the new wiring can be installed. Of course, these damaged

areas must be patched once the wiring is installed. The second way is to remove a small portion of the finished area (only enough to give access to voids in walls, ceilings, etc.) and then fish the wires in. The removed portions of the finished area are then replaced after the wiring is complete.

Where outlet boxes are used, they should be designed for installation in the type of finish in the area. Means of securing the boxes to some structural member-like mounting ears or holding devices—should be given consideration.

Another method of providing outlets in a finished area is to remove the existing baseboard and run the conductors in the usual groove between the flooring and the wall and then replace the baseboard. This method requires less work (cutting and patching) than most other methods when disturbing a finished area. There is also a type of metal baseboard on the market that may be installed along the floor line and used as a raceway. Most types are provided with two compartments for wires: one for power and one for low-voltage wiring. Using this metal baseboard provides a simple means of routing wires for security/fire-alarm systems with very little cutting or patching. In most cases, wires can be fished from the baseboard up to outlets on the wall, especially if the outlets are less than 3 feet (0.9 m) above the floor. However, if this is not practical, matching surface molding can be installed to blend in very nicely with the baseboard.

When a lot of cutting and patching is required in a finished area, many installers will have a carpenter do the work. The carpenter may know some tricks that will help the alarm-system installers get the system in with the least amount of difficulty. Also, any cutting or patching will be done in a professional manner.

Before doing any actual cutting on an existing building to install security/fire-alarm components, the installer should carefully examine the building structure to ascertain that the wires may be routed to the contacts and other outlets in a relatively easy way. It is possible that a proposed outlet location, for example, could be moved only a foot or two to take advantage of an existing chase. Perhaps a smoke detector or similar component was originally located in a ceiling with insulation, which would make the fishing of cables very difficult. If the detector could be located on a ceiling containing no insulation, the job would be greatly simplified.

When cutting holes in ceilings for outlets, you should spread a drop cloth or paper underneath to catch all dust and dirt. Sometimes an old umbrella can be opened and hung upside down under the spot in the ceiling where the hole is being made to catch the debris and keep it off the rugs and furniture.

Holes for wires and components can be cut through plaster with a chisel, through wood with a keyhole saw after first drilling two or four pilot holes, and in brick or other masonry with a masonry chisel or rotary hammer. To locate the exact spot to cut these openings, first cut a small hole in the center of the spot where the larger one will be made. This hole may then be used to locate the area between studs or—in the case of very old buildings—the cracks between the plaster laths. It is then possible to shift the mark for the outlet openings so that all obstacles can be avoided and the outlet box or component can be properly anchored.

There are a number of ways to pull and fish wires into walls and openings in finished buildings and, with a little ingenuity and careful thought, workers should be able to solve almost any problem of this kind that they may encounter.

When you are pulling wires into spaces between the joists in walls, a flashlight placed in the outlet box hole is often a great help when feeding the wires in or catching them as they are pushed near the opening. Under no circumstances should a candle or other open flame be used for this purpose. If one must see farther up or down the inside of a partition, a flashlight and a mirror used in combination, as shown in figure 8-5, is a great help. Many installers like to make their own mirror by gluing a small 2- by 3-inch (5- by 8-cm) compact mirror on a handle, resembling a wooden tongue depressor. Any type of small flashlight may be used.

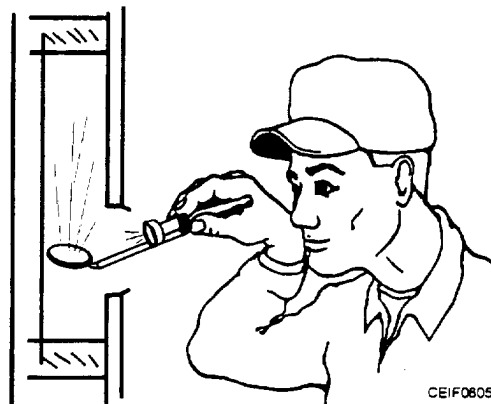

Figure 8-5.—A flashlight and mirror used in combination are useful for viewing conditions inside of partitions.

NEW TECHNIQUES FOR INSTALLING SECURITY/FIRE-ALARM SYSTEMS IN EXISTING BUILDINGS

Presently available are tools that make it much easier to install security/fire-alarm systems in existing buildings. You may now attach a drill bit to a long, flexible spring steel shaft. This makes it possible to easily manipulate a drill bit in walls to accomplish complex installation maneuvers in existing buildings. There are some other tools that are helpful with cable installation. An alignment tool may be used to hold the bit and shaft steady while drilling. Line recovery devices grip the holes located in the shaft end of the drill, thus, allowing one person to quickly fish wires or cables through partitions and shaft extensions.

Where it becomes necessary, to remove floorboards during a security/fire-alarm installation, it should be done with the greatest of care so that the edges are not split. On the finished job, when the boards are replaced, split edges make a poor appearance. Special saws may be purchased for cutting into floors or other surfaces without having to drill holes to start the saw. Then if the tongue (on tongue-and-groove boards) is split off with a thin, sharp chisel driven down in the crack between the boards, the board from which the tongue was removed can be pried up carefully without damaging the rest of the floor.

NEW TECHNIQUES AND PROCEDURES FOR OPERATING EQUIPMENT

If at all possible, a reversible drill motor should be used to withdraw the bit from the wall. The motor should be running only when the bit is actually passing through a wood member. When you are drilling, force is exerted in one direction. When the bit is being removed, it is removed at a different angle and force is exerted from a different direction. This is why the reverse is used. If the flexible shaft is being used with drill motors with no reverse, it would be better to exert force to pull the bit from the hole with the motor running because chances of an easy recovery without damage are much better with the motor running.

When you are drilling from an attic or crawl space, be certain not to select an area directly above or below a door since this will result in property damage. It is also good to keep a slight tension on the wire when it is being pulled from overhead so that it will not get tangled with the bit and become damaged.

The shaft should not be bowed any more than absolutely necessary to accomplish the job. Excessive bowing will decrease the life of the flexible shaft. Drill motors, of course, should be adequately grounded or else have insulated handles.

PUTTING NEW TECHNIQUES INTO PRACTICAL APPLICATIONS

Assume that an outlet box for an infrared photoelectric detector is to be installed above a countertop in a residential kitchen to sense entry of unauthorized persons through the kitchen door. If, upon investigation of the space inside of the partitions, it is found that a 2- by 4-inch (5- by 10-cm) wood member (fire stop) blocks the route from the outlet hole to the basement area where the alarm control station is located, an alignment tool must be used.

The flexible shaft, containing a drill bit, is placed through a cut outlet-box opening and then the special alignment tool is attached to the shaft, as shown in figure 8-6. The shaft will bow back toward the operator by keeping the alignment tool in the same position to the shaft and by lifting the handle. As the bit is lowered into the wall cavity, the operator can feel the bit strike the inside wall. When the bit is aligned correctly on the wooden member, the alignment tool is removed while keeping downward pressure on the bit so that it will not slip out of place, and the hole is drilled through a fire stop. This hole will then act as a guide for drilling through the floor plate, as shown in figure 8-7.

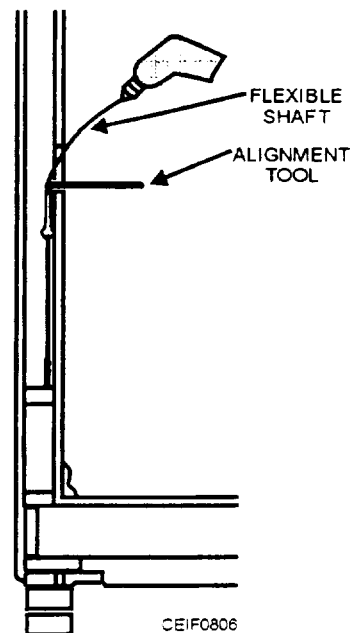

Figure 8-6.—The alignment tool is attached to the shaft, ready for operation.

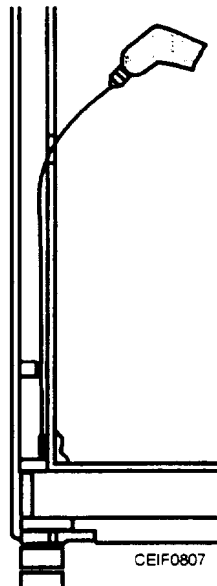

Figure 8-7.—The first hole cut acts as a guide for drilling through the floor plate.

In the case of a wall cavity without tire stops or purlins, the alignment tool is used to snap the bit back to the inside wail (fig. 8-8) at which time downward pressure on the drill motor will keep the bit point in place and cause the shaft to bow. Power and pressure are then transmitted from the back wall that allows proper angle drilling to miss the joint boxing.

After the bit has penetrated into the basement area, as shown in figure 8-9, the operator has access to the hole in the drill bit itself for attaching the recovery grip

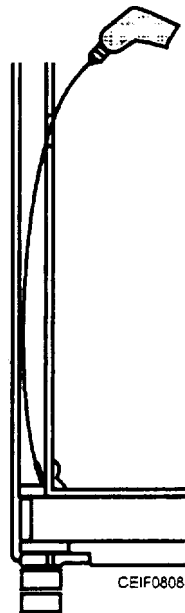

Figure 8-8.—Alignment tool used to snap the bit back to the inside wall.

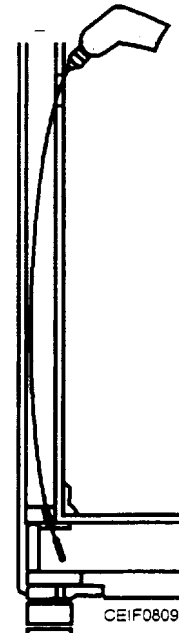

Figure 8-9.—Bit has penetrated into basement area.

and pulling the wire up to the outlet location—all without damage to existing finishes.

Figure 8-10 shows how the recovery grip is attached to the bit tip eyelet. The swivel, located between the cable and the head of the grip, prevents the wire or cable from becoming twisted during the fishing process.

Figure 8-11 shows the grip after it has been attached to the bit tip with the line inserted, ready for recovery. The operator uses the drill motor in reverse and applies a slight pull. The wire then can be pulled easily through the holes because of the reverse cutting action of the bit. If desired, the drill motor can be removed from the shaft and a recovery grip attached to the chuck end of the shaft for pulling the wires downward toward the basement. While this example shows the method of routing wires or cables from an outlet to a basement, the same procedure would apply for drilling from an outlet opening to an attic space.

To install contacts on windows for a burglar-alarm system, drill from the location of the contact through the casement, lintels, and plates with a 3/8-inch (0.9-cm) shaft. Attach a recovery grip to the end of the bit, insert the wire to keep the grip from becoming tangled, reverse the drill motor, and bring the wire toward the operator as the bit is being withdrawn.

Burglar-alarm contacts or door switches installed at doors are simple projects when one uses the flexible shaft. First cut or drill the entrance hole in the normal manner and then insert the flexible shaft with bit into



CEIF0810

Figure 8-10.—Recovery grip attached to the bit tip eyelet.

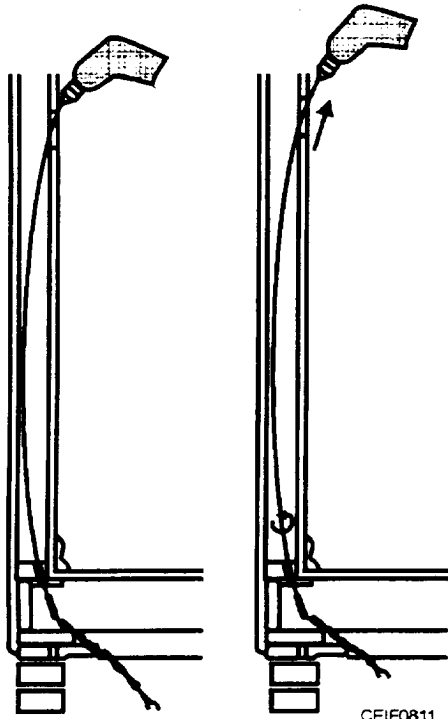

CEIF0811

Figure 8-11.—Grip attached to the bit tip with the line inserted, ready for recovery

the entrance hole, slanting the bit as much as possible in the desired direction of travel. Continue by drilling through the door casing and floor jamb into the cavity of the wall, as shown in figure 8-12, view A. A similar procedure is followed when drilling for window installation as shown in figure 8-12, view B. The drill is then stopped until it strikes the next stud that will deflect the bit either up or down, depending on the direction of the drilling. Continue to push the bit until it strikes the top of the bottom plate and then drill through the plate into the basement or attic. The recovery grip is then attached to the bit and the wire or cable may be drawn back toward the operator by reversing the drill motor and keeping a slight tension on the wires, as they are being pulled to prevent tangling.

With conventional tools, the routing of wires from one outlet to another, as shown in figure 8-13, requires either channeling the wall; using wire mold; or running the wires down to the baseboard, removing the baseboard, and then installing the wires behind it. Instances like these occur when the crawl space is too shallow for workers to crawl into or the house is built on a concrete slab. However, with the flexible shaft, it

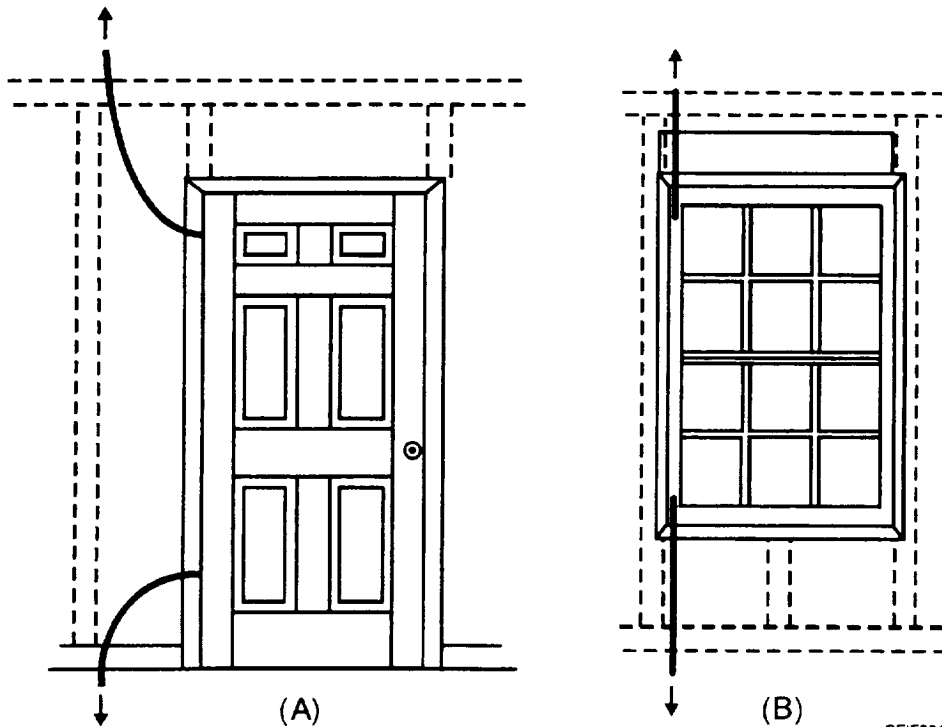

CEIF0812

Figure 8-12.—Drilling through the doorjamb (A) and window casing (B) into the cavity of the wall.

is possible to drill through the wall horizontally through several studs (if the operator is careful) and then pull the wires back through the holes to the openings.

The installation of an outside annunciator under the eave of a house with an extremely low pitch to the roof would cause several problems in getting wires to the outlet. With the flexible shaft, a hole can be drilled through the boxing, as shown in figure 8-14. As soon as the bit penetrates the boxing, it is pushed into the attic as far as it will go. A recovery grip is then attached to the bit, the wire or cable inserted, and then pulled backward toward the outlet opening. The outlet box and annunciator (horn, bell, etc.) are installed under the eave and the other end of the cable is connected to the alarm system. Also, because the flexible shaft is more rigid than the conventional fish tape, it will penetrate attic insulation if any exists.

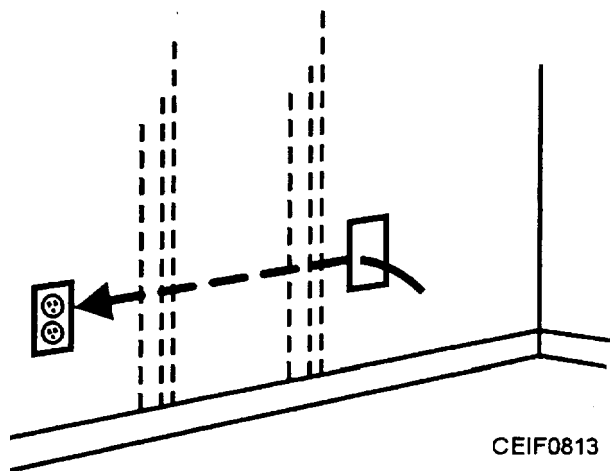

Figure 8-13.—How wires must be routed when one uses conventional tools.

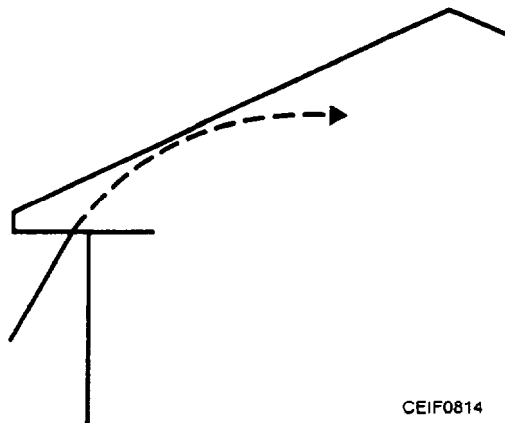

Figure 8-14.—Method of drilling a hole through boxing by using a flexible shaft.

If it becomes necessary to install wiring in an attic and run cable from this area to the basement, the installation can be greatly simplified by using a flexible shaft. First drill through the top plate into the wall cavity, making sure that the drilling is not being done above a window or doorway or any other obstruction, such as existing wiring, ductwork, and so forth. Once through the top plate, the drill motor is turned off and the bit is pushed into the cavity of the wall as far as it will go. If no fire stops are encountered, the bit is pulled back and an extension is attached to the shaft. With the extension installed, the bit is again lowered into the wall cavity until a fire stop is encountered. The bit is then positioned and used to drill through the wooden member. Once the wooden member is penetrated, the drill motor is again stopped and the bit is lowered further until the bottom plate is reached. Continue drilling through the bottom plate in the basement or crawl space. Fasten the appropriate recovery grip, insert the wire or cable, and pull up the wire with the flexible shaft. The drill motor should be reversed only when the bit is passing through one of the wooden members.

Those who use the flexible shaft device often are certain to discover many other useful techniques for installing wiring in existing structures.

COMPONENTS OF SECURITY/FIRE-ALARM SYSTEMS

Wire sizes for the majority of low-voltage systems range from No. 22 to No. 18 AWG. However, when larger-than-normal currents are required or when the distance between the outlets is long, it may be necessary to use wire sizes larger than specified to prevent excessive voltage drop. Voltage-drop calculations should be made to determine the correct wire size for a given application even on low-voltage circuits.

The wiring of an alarm system is installed like any other type of low-voltage system. The process consists of locating the outlets, furnishing a power supply, and finally interconnecting the components with the proper size and type of wire.

Most closed systems use two-wire No. 22 or No. 24 AWG conductors and are color-coded for identification. A No. 18 pair normally is adequate for connecting bells to controls if the run is 40 feet (12 m) or less. Many electricians, however, prefer to use No. 16 or even No. 14 cable.

Some of the various components for a typical security/fire-alarm system are shown in figure 8-15.

CONTROL PANEL

This is the heart of any security system. It is the circuitry in these control panels that senses a broken contact and then either sounds a local bell or horn or omits the bell for a silent alarm. Most modern control panels use relay type of controls to sense the protective circuits and regulate the output for alarm-sounding devices. They also contain contacts to actuate other deterrents or reporting devices and a silent holdup alarm with dialer or police-connected reporting mechanism.

The control unit also continuously monitors the condition of the alarm-initiating-and-indicating-circuit wiring and provides a trouble indication in the event of an abnormal condition in the system, such as an ac power failure or a wiring failure.

The control unit is usually housed in a sheet-metal cabinet (fig. 8-16). The control unit usually provides annunciation of signals (telling where a signal originates).

Because all circuits end at the control unit, it is a convenient test location. Test switches (if provided)

are usually inside the locked door of the control unit. If the switches are key-operated, they may be on the control unit cover, rather than inside the cabinet.

POWER SUPPLIES

Power supplies vary for different systems; but, in general, they consist of rechargeable 6-Vdc power supplies for burglar-alarm systems. The power packs usually contain nickel-cadmium batteries that are kept charged by 12-Vac input from a plug-in or otherwise connected transformer to a 120-volt circuit. Better power supplies have the capability of operating an armed system for 48 hours or more without being charged and still have the capacity to ring an alarm bell for 30 minutes or longer. Power supplies are obviously used in conjunction with a charging source and supply power for operation of the alarm system through the control panel.

Many older local alarm systems are powered by alternating current (ac) power only with no provision for standby, battery power. In these cases, two separate ac circuits (usually 120/240 Vac) are used: one to power the fire-alarm system operating circuits and another to power the trouble-signaling circuits of the system. Low-voltage alarm systems, especially, those provided with battery standby power, are most often

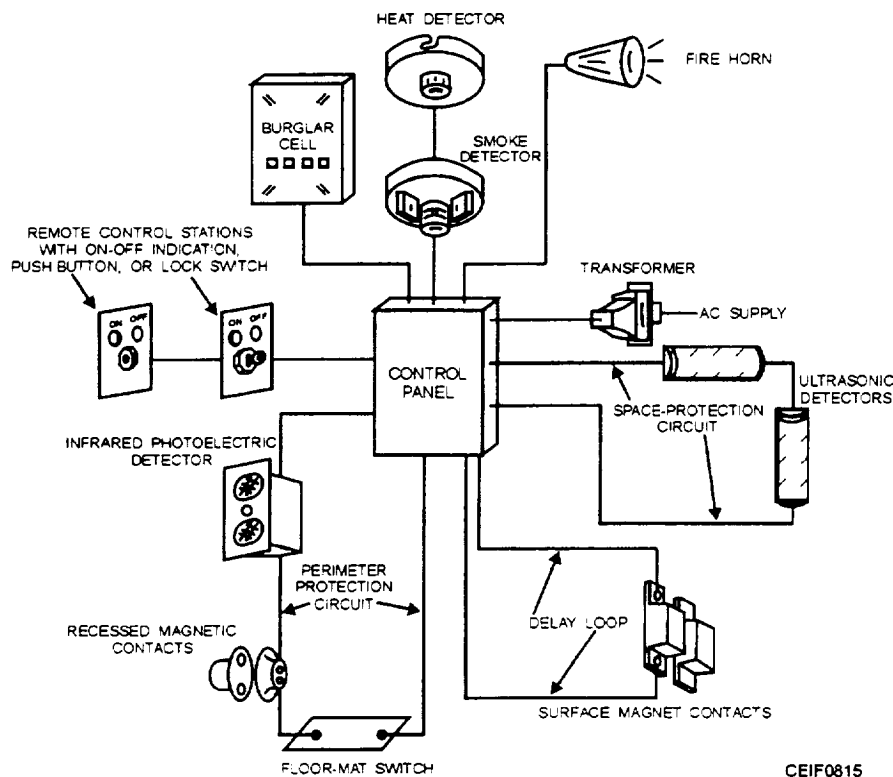

Figure 8-15.—Various components for a typical security/fire-alarm system.

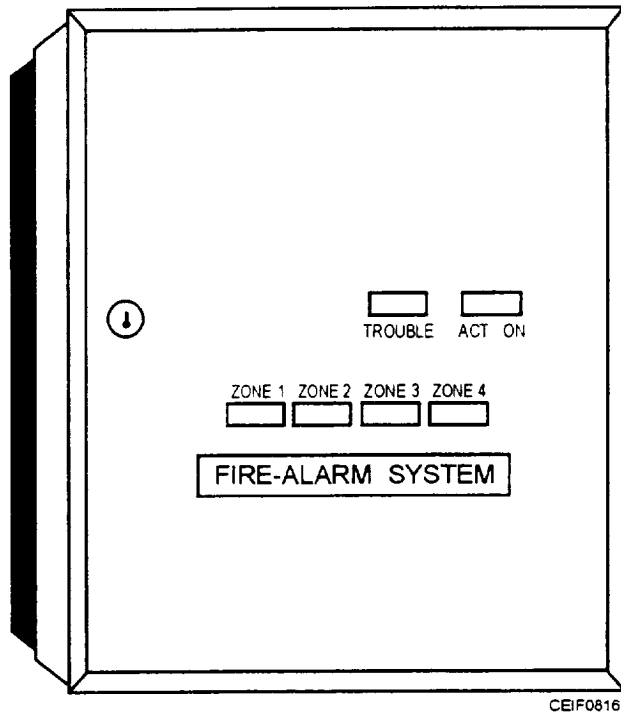

Figure 8-16.—Control unit with annunciation.

found where some form of automatic fire detection or automatic fire extinguishing is connected to the alarm system. However, recent conversion by most alarm system manufacturers to solid-state electronic design, which is essentially a low-voltage direct-current (dc)

technology, means that the most recent installations are of the low-voltage type.

The power supply of the system refers to the circuitry and components used to convert the ac line voltage to low-voltage ac or dc for operating the alarm system and for charging standby batteries. If the system is an older one with a dry cell, nonrechargeable standby battery (no longer permitted by NFPA standards), the lower supply probably contains a switching arrangement for connecting the battery to the system when ac power fails. Figure 8-17 is a simplified diagram of a typical dc power supply for powering a low-voltage dc alarm system and for charging a rechargeable standby battery.

Transformer T drops the line voltage from 120 volts ac to a voltage in the range of 12 to 48 volts ac. The low ac voltage is rectified by diode bridge D, and the resulting dc voltage powers the alarm system through relay contacts S1 and charges battery B through the current limiting resistor R. When normal ac power is available energizing relay coil S, contacts S1 are closed. If ac power fails, S1 opens and S2 closes, connecting the battery to the alarm system. Fuse F1 protects against a defect in the power supply or the alarm system during normal ac operation. Fuse F2 protects against alarm circuits defects that would cause a battery overload during dc-powered operation.

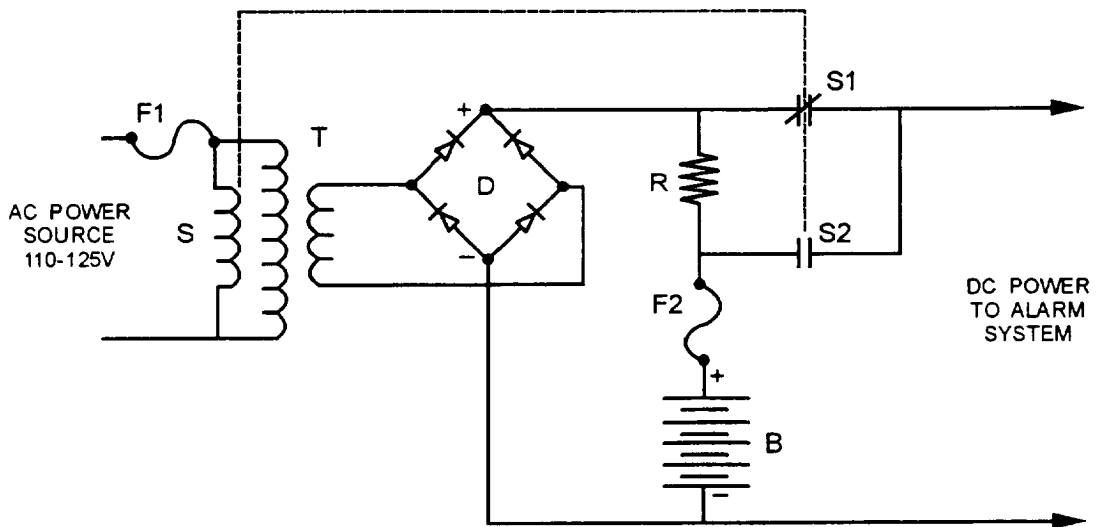

- | | | |
|-----------|----|---|
| F1 AND F2 | -- | OVERCURRENT PROTECTIVE FUSES |
| S | -- | AC POWER SENSING RELAY COIL (CONTROLS CONTACTS S1 AND S2) |
| T | -- | VOLTAGE STEP-DOWN TRANSFORMER |
| D | -- | FULL-WAVE RECTIFIER BRIDGE |
| B | -- | RECHARGEABLE STANDBY BATTERY |
| R | -- | CHARGE CURRENT LIMITING RESISTOR |
| S1 | -- | CLOSED CONTACT WITH RELAY S ENERGIZED |
| S2 | -- | OPEN CONTACT WITH RELAY S ENERGIZED |

CEIF0817

Figure 8-17.—Typical dc power supply and battery charger.

Removal of resistor R eliminates the battery-charging feature and allows the use of a dry-cell battery that sits idle until ac power fails. At that time, S1 pens and S2 closes, connecting the battery to the alarm system.

There are many variations of this basic power supply design. These variations add such features as voltage regulation, current limiting, and automatic high-rate/low-rate charging, controlled by the state of the battery charge. All designs normally provide current and voltage meters, pilot lamps, and switches for manual control of charging rate.

ENTRY DETECTORS

The surface magnetic detector is the most versatile entry detector for residential alarm systems and should be considered first as a method of protecting any movable door or window. These detectors can be mounted on wood, metal, and even glass, if necessary. They can be mounted with screws, double-sided tape, or epoxy. Obviously, the tape and epoxy are useful on glass, aluminum, or any other surface where screws cannot be used. However, when applying tape or epoxy, make certain that the surface is clean, dry, smooth, and at least 65°F (18°C).

Surface-Mounted Magnetic Contacts on Double-Hung Windows

A switch is mounted on the window casing with a magnet on the window (fig. 8-18). As long as the switch and magnet are parallel and in close proximity when the window is

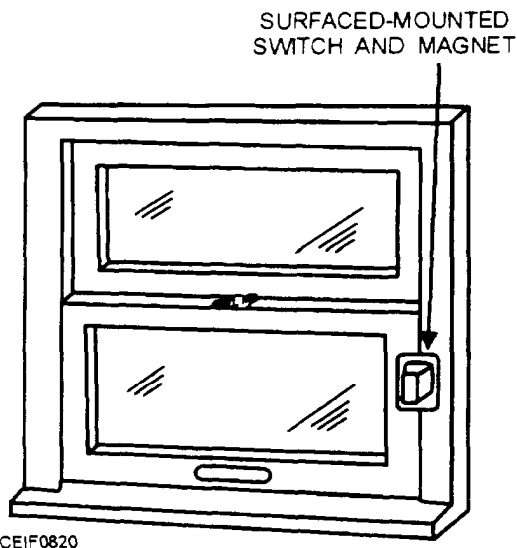

CEIF0820
Figure 8-18.—Double -hung window with surface-mounted magnetic contacts.

shut, they may be oriented side-to-side, top-to-side, or top-to-top.

Surface-Mounted Magnetic Contacts on Doors

Where appearance is not the most important consideration, the use of a surface-mounted switch (on the doorframe) and a magnet (on the door) will simplify installation (fig. 8-19).

Recessed Magnetic Contacts in Doors and Casement Windows

Where the appearance of surface-mounted systems is objectionable, recess-mounted magnetic protectors may be used. These detectors are more difficult to install and require greater care on the installer's part, but few problems develop if the following precautions are taken.

1. Be careful not to damage or destroy any weatherproofing seal around windows, doors, or other openings.

2. If a recess-mounted entry detector is installed in the windowsill, you must prevent water seepage to the switch by applying a sealant under the switch flange and around the switch body.

3. When drilling holes to accept each half of the detector, be sure the holes line up. Holes are drilled in the door and in the casing, one directly across from the other, and a pair of wires from the positive side of the

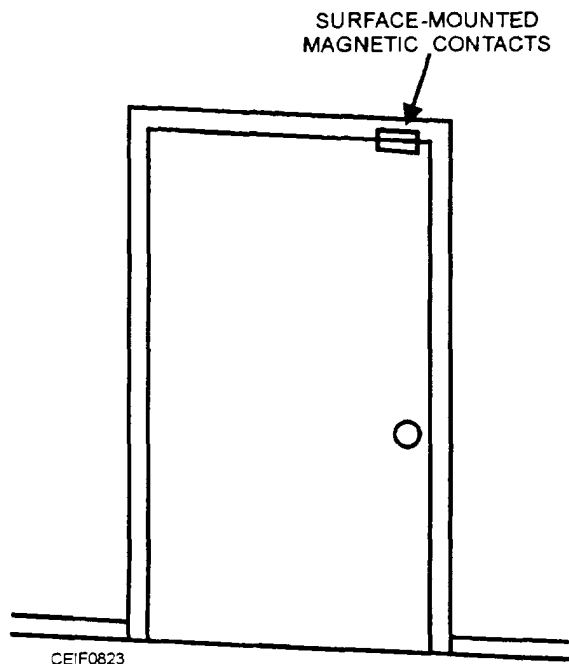

CEIF0823
Figure 8-19.—Surface-mounted magnetic contacts on door..

protective circuits is run out through the switch hole (fig. 8-20). There should be no more than 1/4-inch (0.6 cm) space for windows and 1/8-inch (0.3 cm) for doors between the two sections of the detector.

4. Be certain there is enough space between the window and its frame (or door and its frame) when each is closed; that is, there must be enough space (usually equaling 1/16 inch or 0.16 cm) for the protrusion of both sections when they meet.

5. A switch and magnet are installed preferably in the top of the window and underside of the upper window casing, where they will be least noticeable (fig. 8-21). If the window frame is not thick enough to accept the magnetic section of the detector, the detector can be mounted in the side frame.

Conductive Foil on Glass Doors

A self-adhesive foil block (terminator) on the door is connected to a similar unit on the doorframe by a short length of flexible cord to allow for door movement (fig. 8-22). The foil is connected in the positive conductor of the protective circuit and is adhered to the glass parallel to and about 3 inches (7.6 m) from the edge of the glass, using recommended varnish. Breaking the glass breaks the foil and opens the circuit. A double circuit of foil may be taken from the foil block to provide more coverage. Coiled, retractable cords are available for use between foil blocks to allow for sliding-door travel.

Conductive Foil on Picture Window

Where a window does not open, a single run of foil is connected to a foil block on the glass, frame, or wall (fig. 8-23). When the foil crosses over a frame member, a piece of plastic electrical tape should be used to provide an insulated crossover surface for the foil.

Complete Glass-Door Protection

A glass door with a glass transom may be protected by a combination of magnetic contacts and foil (fig. 8-24).

Recessed Plunger

The recessed plunger detector shown in figure 8-25 is mounted so that the door or window will contact the plunger at the tip and push the plunger straight in. Therefore, the area of the window or door that depresses the plunger should have no slots, cutouts, or step-downs into which the plunger might slip. The area also should be hard and free of rubber or vinyl that might be weakened by the plunger and consequently allow the plunger to open. For protecting doors, plunger type of detectors should be mounted only in the doorframe on the hinge side of the door.

Space Detectors

In cases where it is difficult to protect a window or door by mounting any of the direct type of detectors, the area directly inside the door or window can be protected with interior "space" detectors, such as a floor-mat detector (fig. 8-26) or an ultrasonic motion detector (fig. 8-27).

Floor-mat detectors are easily concealed under rugs at doors, windows, top or bottom of stairways, or any other area onto which an intruder is likely to step. Light pressure on the mat triggers the alarm.

There are also rolls of super-thin floor matting that can be cut to any desired length. These rolls can be used on stair treads and in areas near sliding glass doors or other larger glass areas, entrance foyers, and so forth. In households with unrestricted pets, these mats are almost useless since the pets roam around the home and are certain to step on one of the mats and trigger the alarm.

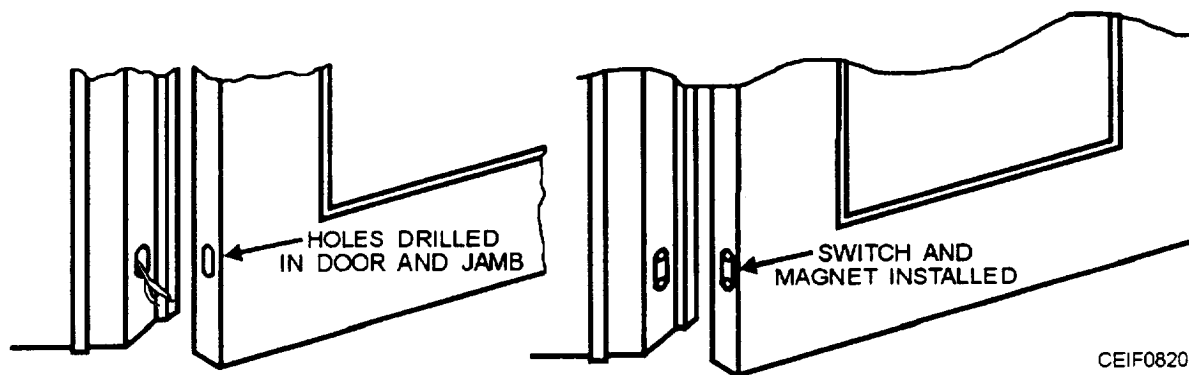

Figure 8-20.—Recessed magnetic contacts in door.

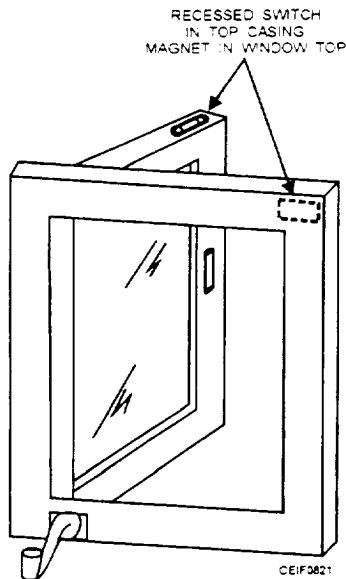

Figure 8-21.—Recessed magnetic contacts in casement window.

Other space detectors include ultrasonic motion detectors, audio detectors, and infrared detectors. Care must be used with any of these units because the protected area is limited both in width and depth--depending upon the particular unit.

The ultrasonic motion detector can be used in large glass-walled rooms that might otherwise be difficult to protect and in hallways or entries or in virtually any area an intruder would have to pass through in moving about a home or business. They are especially useful as added protection (when conventional detectors are used also) to monitor a "valuables" room or area.

Most ultrasonic motion detectors are designed for mounting on either the wall or ceiling. It emits inaudible high-frequency sound waves in an elliptical pattern that ranges from 12 feet (4 m) to 5 feet (11 m)

long, by 20 feet (6 m) wide, by 5 feet (2 m) high for most residential models. When an intruder moves within the secured area, movement interrupts the established pattern of sound waves and sounds the alarm.

Some designs of motion detectors can be rotated up to 180° for maximum coverage of the area being monitored, as shown in figure 8-28.

Another type of motion detector is the audio detector (fig. 8-29). This type senses certain sharp sounds known to be present in forced entry, such as wood splintering or glass breaking. When these sounds are received through the miniature microphone of the unit, the detector triggers the control unit to sound an alarm.

Audio detectors are best utilized in areas that are seldom used, such as an attic, a garage, or a closed-off wing. They can be used in other areas, but when such areas are subject to much daytime activity, it is recommended that the detector only be armed at night when the business is closed or the family retires or is away from home.

Infrared detectors are another type of motion detector. A combination transmitter-receiver is used to project an invisible pulsating beam at a special bounce-back reflector on an opposite wall. Any interruption of the beam activates the system alarms. Infrared detectors can be wired to either the perimeter or interior circuit; but for faster response, it is recommended that it be connected to the interior circuit.

Infrared detectors are designed for indoor areas, such as entries, hallways, rooms, and so forth. Most cover a span from 3 feet (1 m) to 75 feet (23 m), so it may be used in practically any indoor area or room.

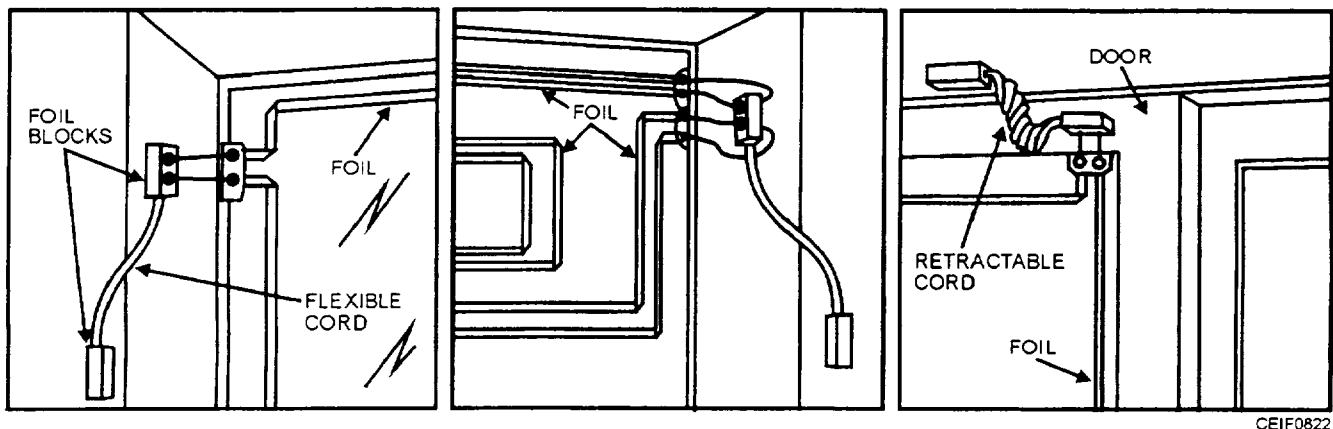

Figure 8-22.—Conductive foil on glass doors.

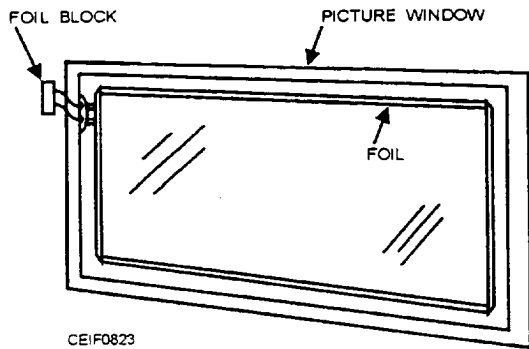

Figure 8-23.—Conductive foil on picture window.

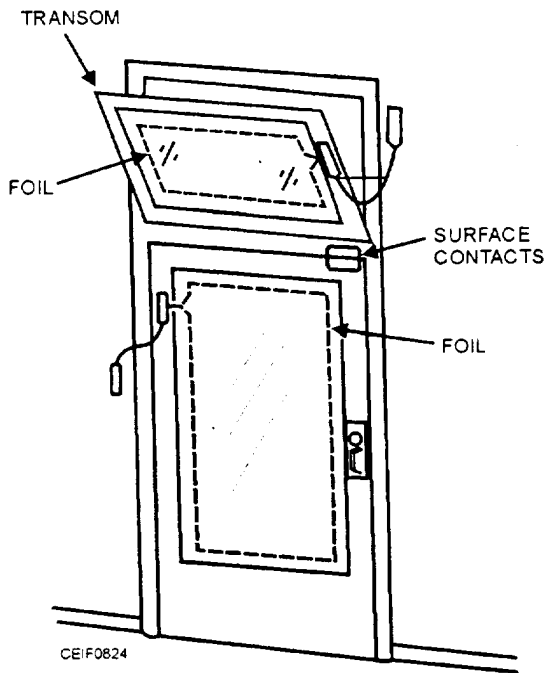

Figure 8-24.—Complete glass-door protection.

ADDITIONAL COMMERCIAL/ INDUSTRIAL COMPONENTS OF SECURITY/FIRE-ALARM SYSTEMS

Industrial security/fire-alarm systems are essentially the same as those used for residential applications. There are, however, a few additional components that are used mostly in industry.

Vibration detectors are often used on industrial buildings to detect vibrations caused by forced entry. Such detectors have been used on a variety of construction materials, such as hollow tile, plaster and lath, brick, concrete, metal ceilings, and wood. Once mounted in place, they may be adjusted with a setscrew for the desired sensitivity.

Some factories maintain a security fence equipped with fence-guard detectors. This type of detector will detect climbing, cutting, or any other penetration of the fenced area. Most of these detectors operate on standard closed-circuit controls as described previously.

Fence-guard detectors use a vertical-motion detector that is sensitive to movement created by climbing or cutting the fence. Normal side motions, such as wind or accidental bumping, do not affect the detector and cause false alarms. The detectors are normally mounted about midway up the fence and every 10 feet (3 m) of fence length. Most of these devices set off the alarm if they are tampered with or if the wire is cut. They may be connected to a control panel and the alarm will sound in the form of a bell or horn, or it will silently dial the local law-enforcement agency.

Another type of detector that is used is the outdoor microwave detector. This detector is used for protecting large outdoor areas like car lots, construction sites, and factory perimeters. In operation, a solid, circular beam of microwave energy extends from a transmitter to the receiver over a range of up to 1,500 feet (457 m) for some brands. Any movement inside of this beam (fig. 8-30) will activate the alarm.

Thermistor Sensors

The continuous linear thermal sensor is a small-diameter coaxial wire that is capable of sensing temperature changes along its entire length. The sensor is made up of a center conductor and an outer stainless steel sheath. The center conductor is electrically insulated from the outer sheath by a ceramic thermistor material, as shown in figure 8-31.

Since the thermistor has a negative coefficient of resistance, the electrical resistance between the center wire and the outer sheath decreases exponentially, as the surrounding temperature increases (fig. 8-32).

The changing resistance is monitored by one of several control panels that then can actuate extinguishing systems or any other electrically controlled devices.

Such sensors have a diameter of approximately 0.080 inch (0.2 cm) and, therefore, have a small mass that permits them to sense changes in temperature rapidly. They can sense temperatures from 70°F (21°C) up to 1200°F (649°C) if the thermistor material is properly selected.

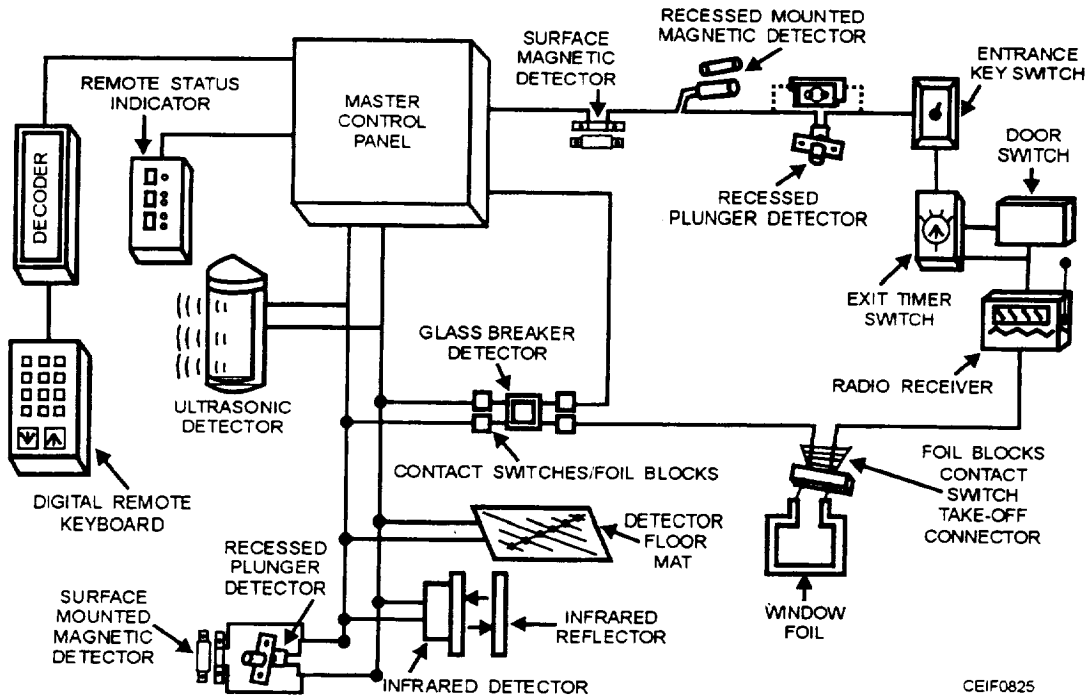

Figure 8-25.—Various components of a residential security/fire-alarm system.

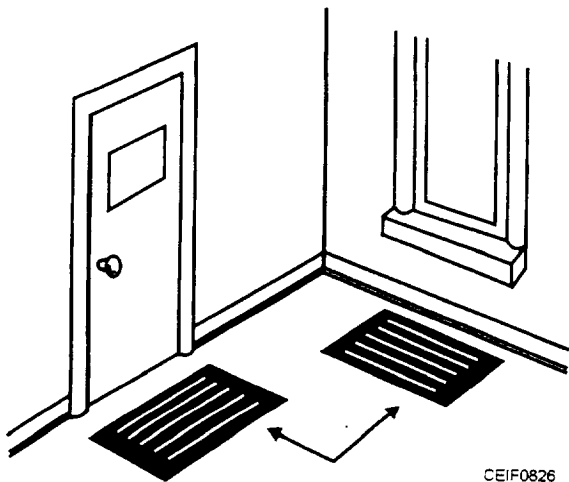

Figure 8-26.—Floor-mat detector.

Since electrical resistance is measured across two wires (center and sheath), the sensor has the ability to detect a high temperature on a short wire as well as a lower temperature on a longer one.

The elements are mounted by clamps spaced along their lengths and the detectors, being all solid state, have only two electrical failure modes: open circuit and short circuit. Both of these conditions can be caused only by mechanical means and are minimized by rigid mounting. Figure 8-33 shows the construction and mounting details.

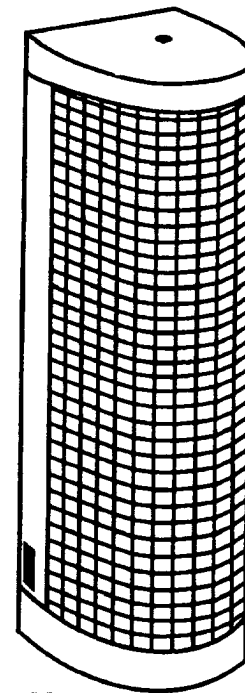

Figure 8-27.—Ultrasonic motion detector.

Ultraviolet-Radiation Fire Detectors

Ultraviolet-radiation fire detectors combine large-scale integration circuit techniques with an ultraviolet detection assembly to form a simple, yet flexible, fire-detection system.

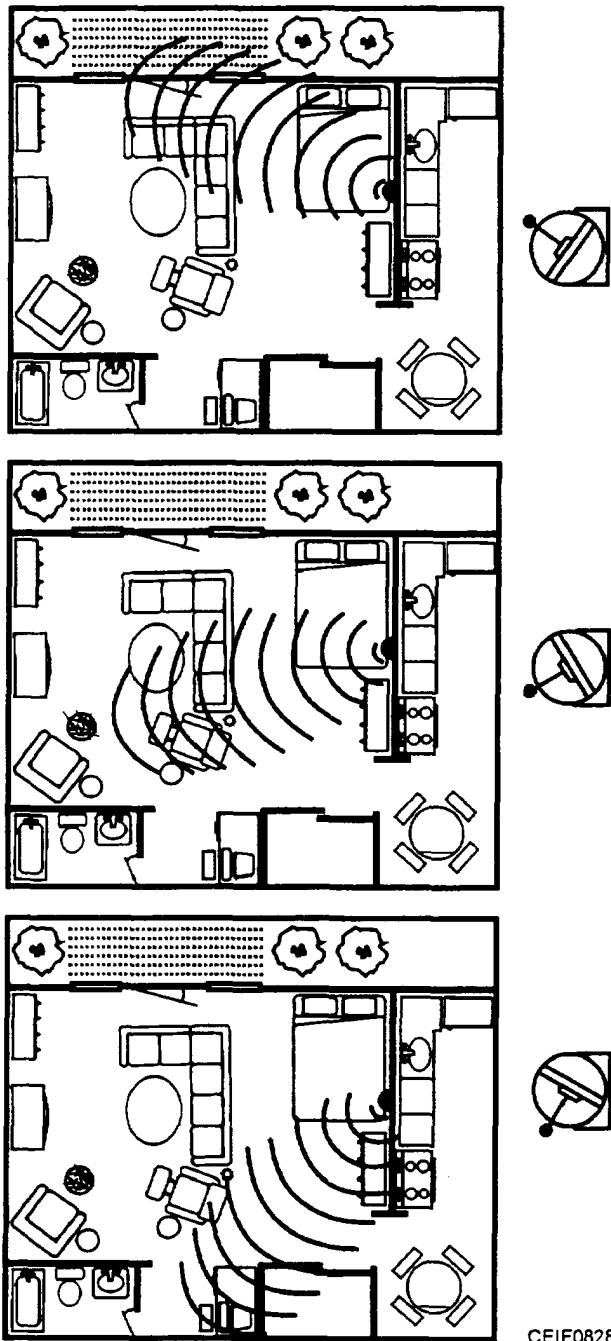

Figure 8-28.—Motion detector rotating up to 180° for maximum coverage.

The basis of this type of system is a gas-detection tube using the Geiger-Mueller principle to detect radiation wavelengths extending from 2000 to 2450 angstroms (Å) ($1 \text{ \AA} = 10^{-8} \text{ cm}$). Figure 8-34 displays the radiation sensitive area of the tube and compares this area to other forms of radiation. It should be noted that visible radiation does not extend into the sensitive area of the detector. Similarly, radiation from artificial lighting sources does not extend into the sensitive area of the detector.

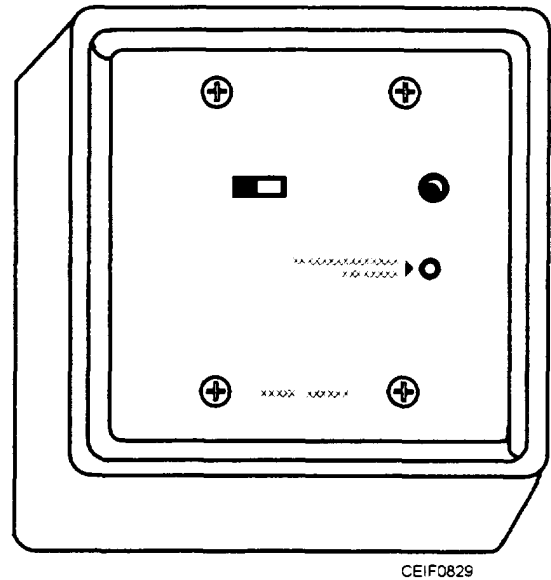

Figure 8-29.—Audio detector.

Welding arcs and lightning strikes, however, will generate radiation to which the detectors are sensitive and precautions must be taken to minimize these effects.

The ultraviolet-radiation detector's focus of sensitive points is a 60-degree spherical cone whose apex lies at the detector tube. Figure 8-35 indicates the relationship between viewing angle and relative sensitivity. The sensitivity of the detector tube is a characteristic of its cathode material and is fixed, but its voltage-pulse output rate varies both with flame size and flame viewing distance. The pulse output rate is directly proportional to flame size; that is, it increases when larger flame fronts are presented to the detector. The pulse output rate is also inversely proportional to the distance of the flame front from the detector tube—the pulse output rate decreases as the distance from the detector tube to the flame front increases.

To illustrate, a 1-foot (0.09 m^2) hydrocarbon fire will cause a pulse output rate of 3 pulses per second at a viewing distance of 30 feet (8 m). This same fire will cause a tube pulse output rate of 20 pulses per second at a viewing distance of 20 feet (6 m). In a like manner, 1-foot (0.09 m^2) flame front must be located at a distance of 5 feet (1.5 m) to create a pulse output rate of 30 pulses per second; a 16-foot (1.4 m^2) fire will create the same pulse output rate at a distance of 25 feet (7.6 m), and so forth.

Telephone Dialers

A schematic wiring diagram of a typical telephone dialer is shown in figure 8-36. The two cooperating

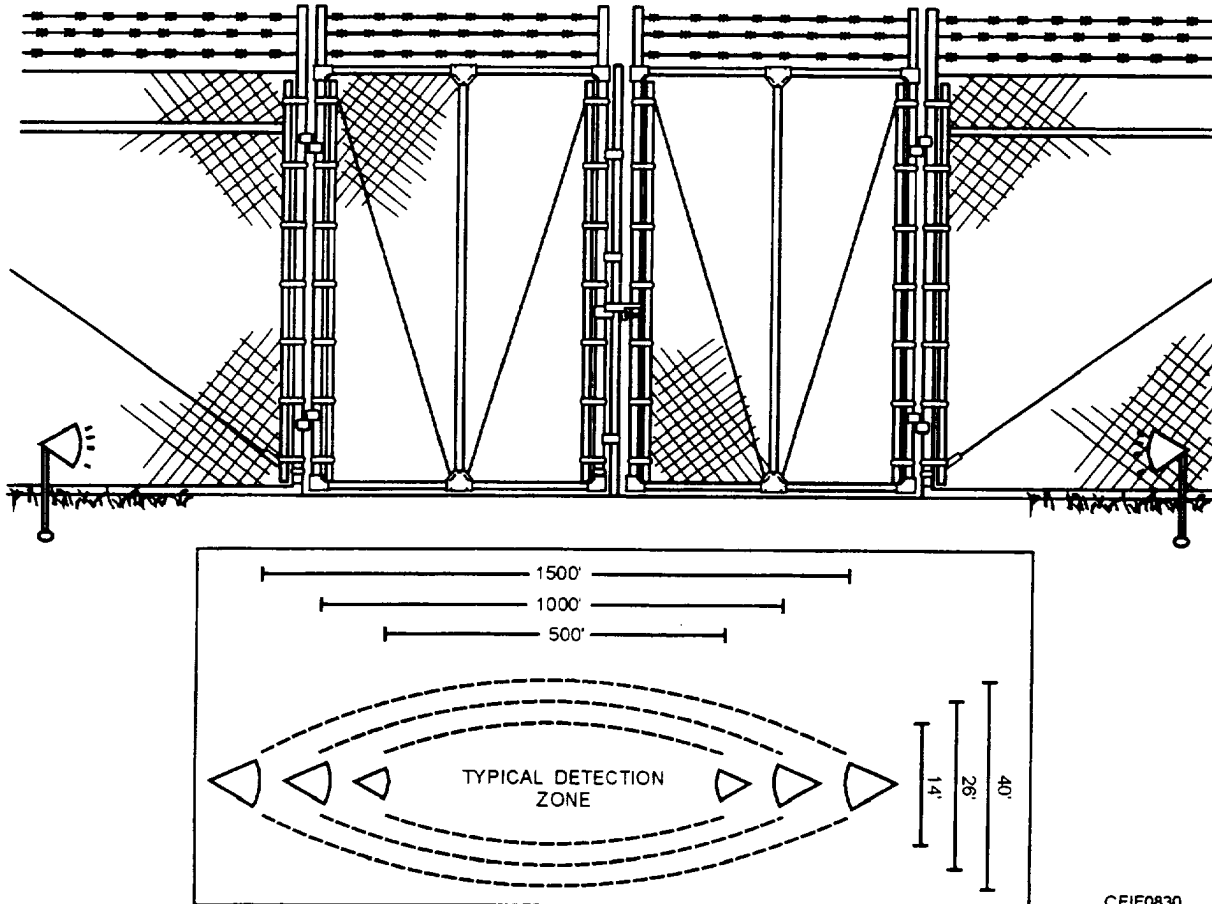

Figure 8-30.—A solid, circular beam of microwave energy extends from a transmitter to the receiver over a range of up to 1,500 feet (457 m).

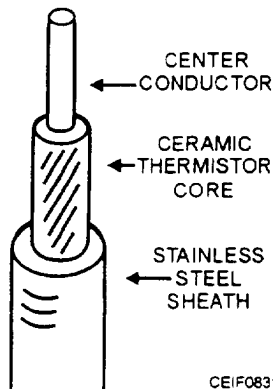

Figure 8-31.—Structure of a heat-sensor cable.

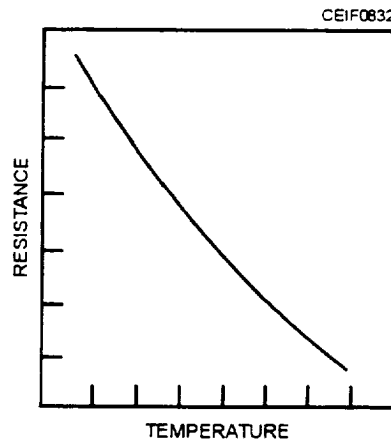

Figure 8-32.—Curve showing relationship of resistance to temperature.

channels of the dialer permit two distinct dialing and message programs. Although labeled as, and most commonly used for, separate burglar and fire alarms the two channels can be connected and programmed for any application: medical emergency, heating-system failure, freezer warmup, and water-pressure failure.

It is important to understand the priority relationship between the two channels before making trigger connections. The priority arrangement ensures

transmission of the vital fire-alarm program (or other priority program on the FIRE channel) in three ways.

1. If the dialer is already operating on the BURGLAR channel when the FIRE channel is triggered, the dialer immediately switches to FIRE-channel transmission

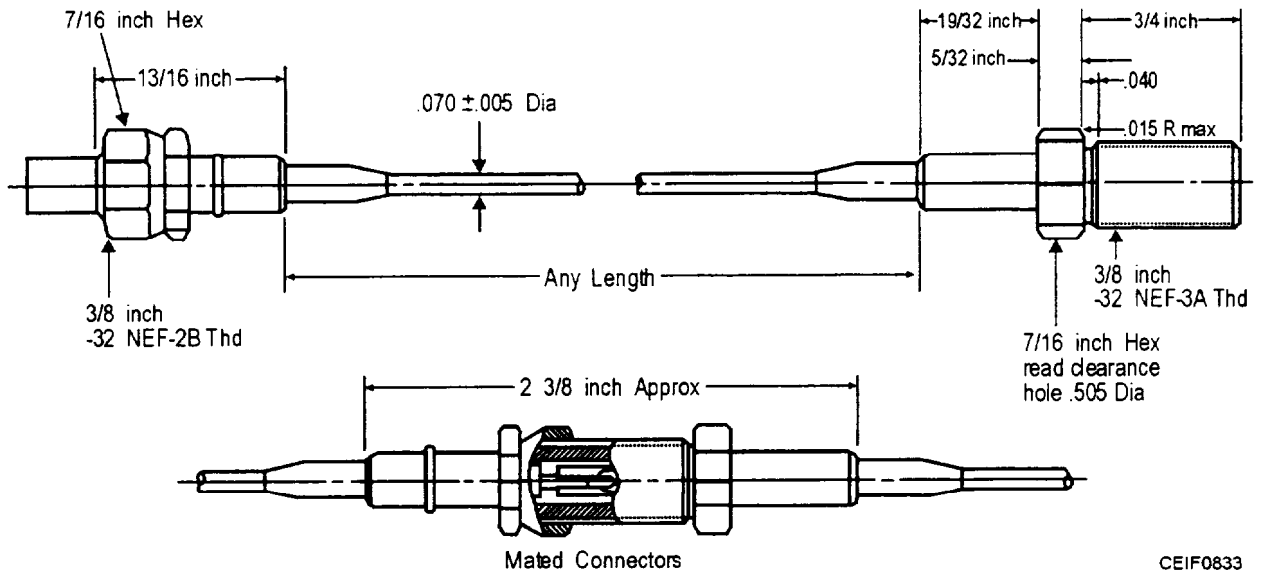

Figure 8-33.—Using connectors to supply desired length of sensor cable.

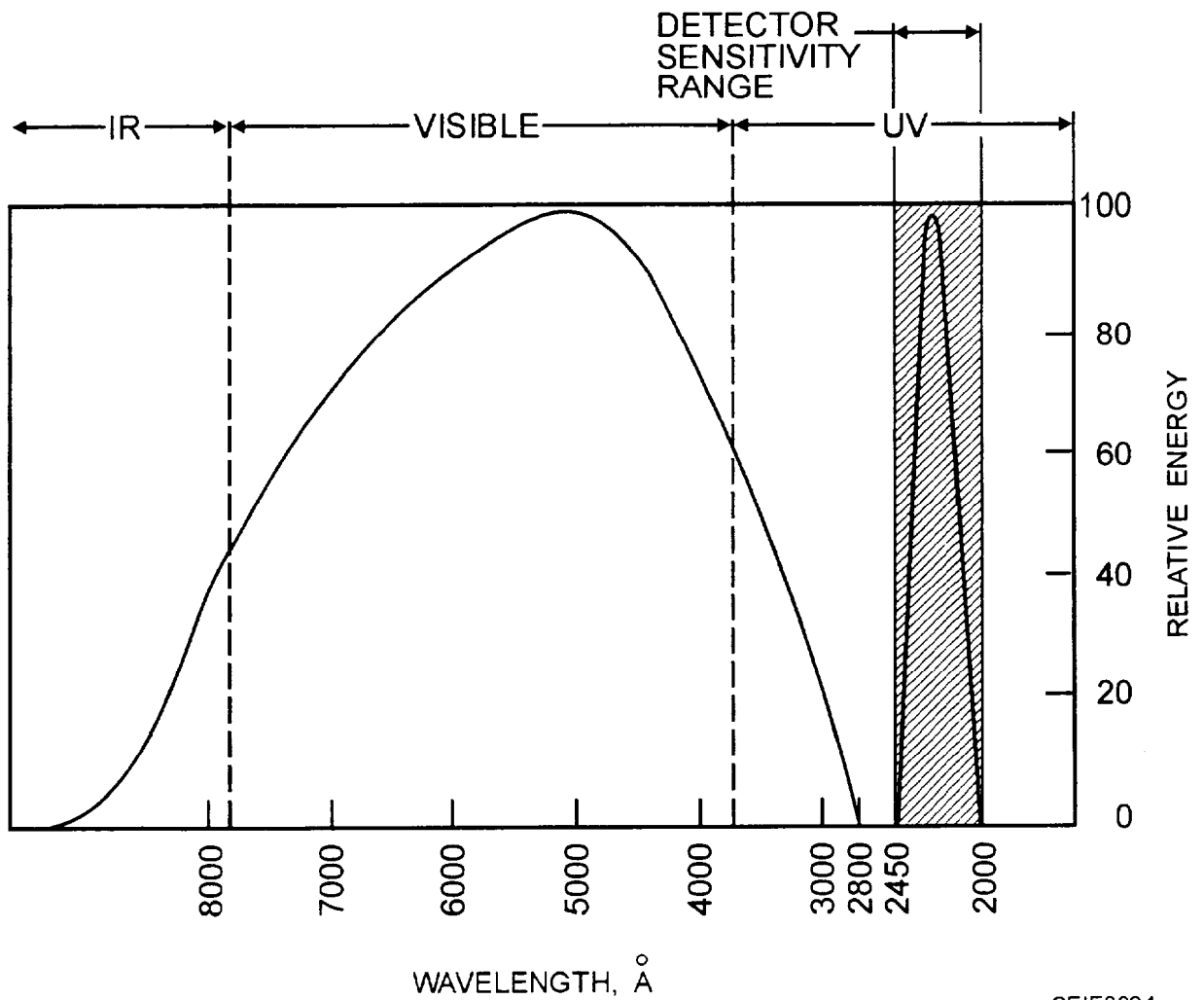

Figure 8-34.—This detector has maximum sensitivity in the ultraviolet range.

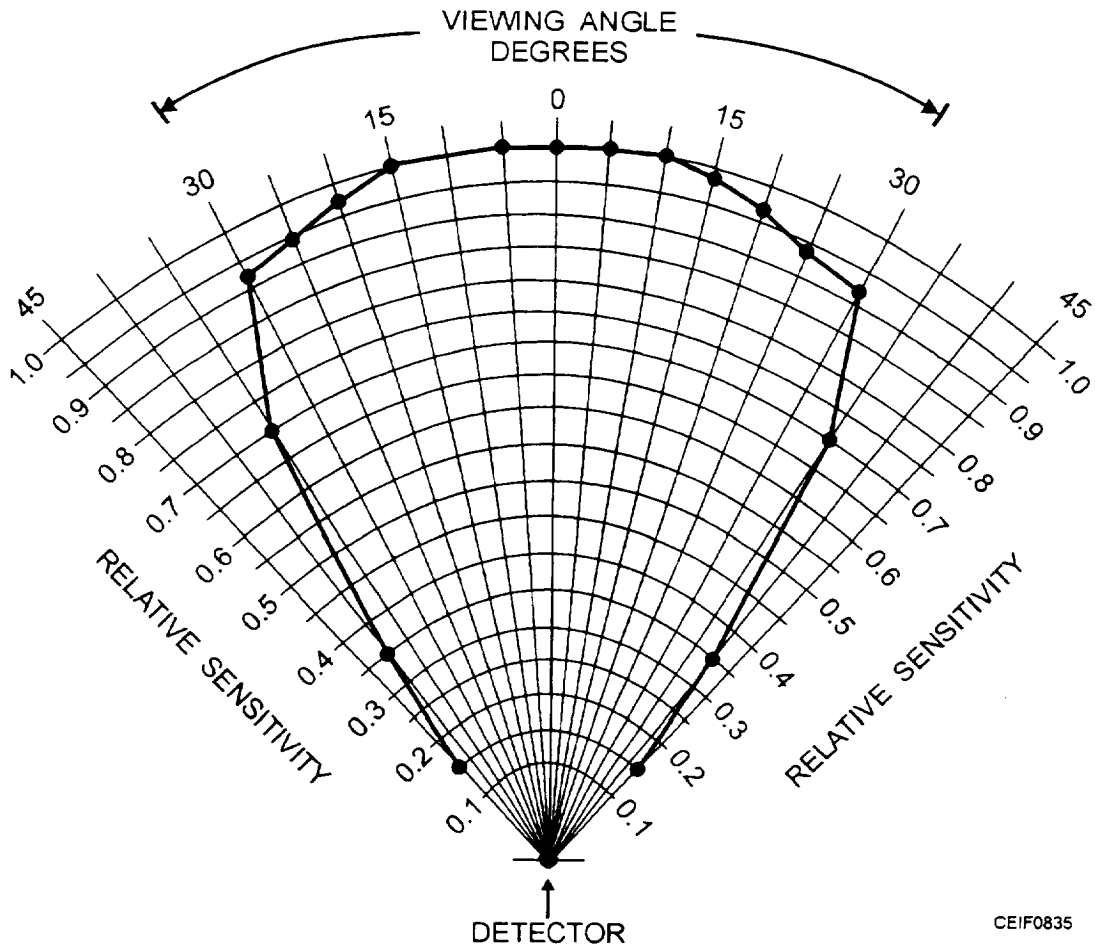

Figure 8-35.—Viewing angle of ultraviolet motion detector.

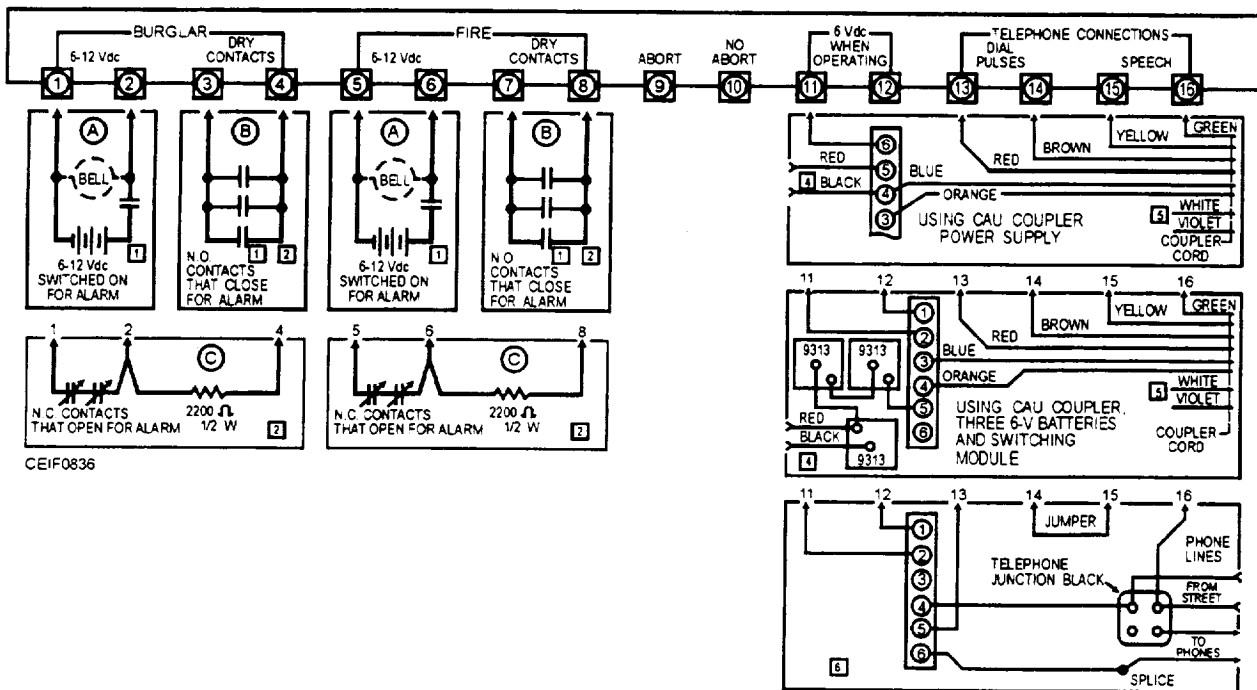

Figure 8-36.—Schematic wiring diagram of a typical telephone dialer.

2. When FIRE-channel priority seizure has occurred, the dialer overrides its normal end-of-cycle stop and runs for another full cycle. This ensures transmission of the entire priority program, even if the FIRE-channel take-over occurred near the end of a BURGLAR-channel cycle.

3. Even if the dialer has stopped after transmitting the full BURGLAR-channel program and the burglar-alarm input is still present, an input on the FIRE channel causes immediate transmission of the FIRE-channel program.

Each of the channels of the dialer can be triggered by a switched dc voltage, a dry-contact closure, or a dry-contact opening. The trigger inputs may be either

momentary or sustained. In either case, the dialer transmits its full program, then stops and resets itself. An input that is still present when the dialer stops must be removed briefly and then applied again to restart transmission on that channel. A sustained input does not make the dialer transmit or interfere with normal use of the telephones, nor does it interfere with triggering and operation of the dialer on its other channel.

When available, an appropriate dry-contact closure should be used instead of a switched voltage for the dialer-trigger input. Figure 8-37 shows the preferred connections for a typical telephone dialer.

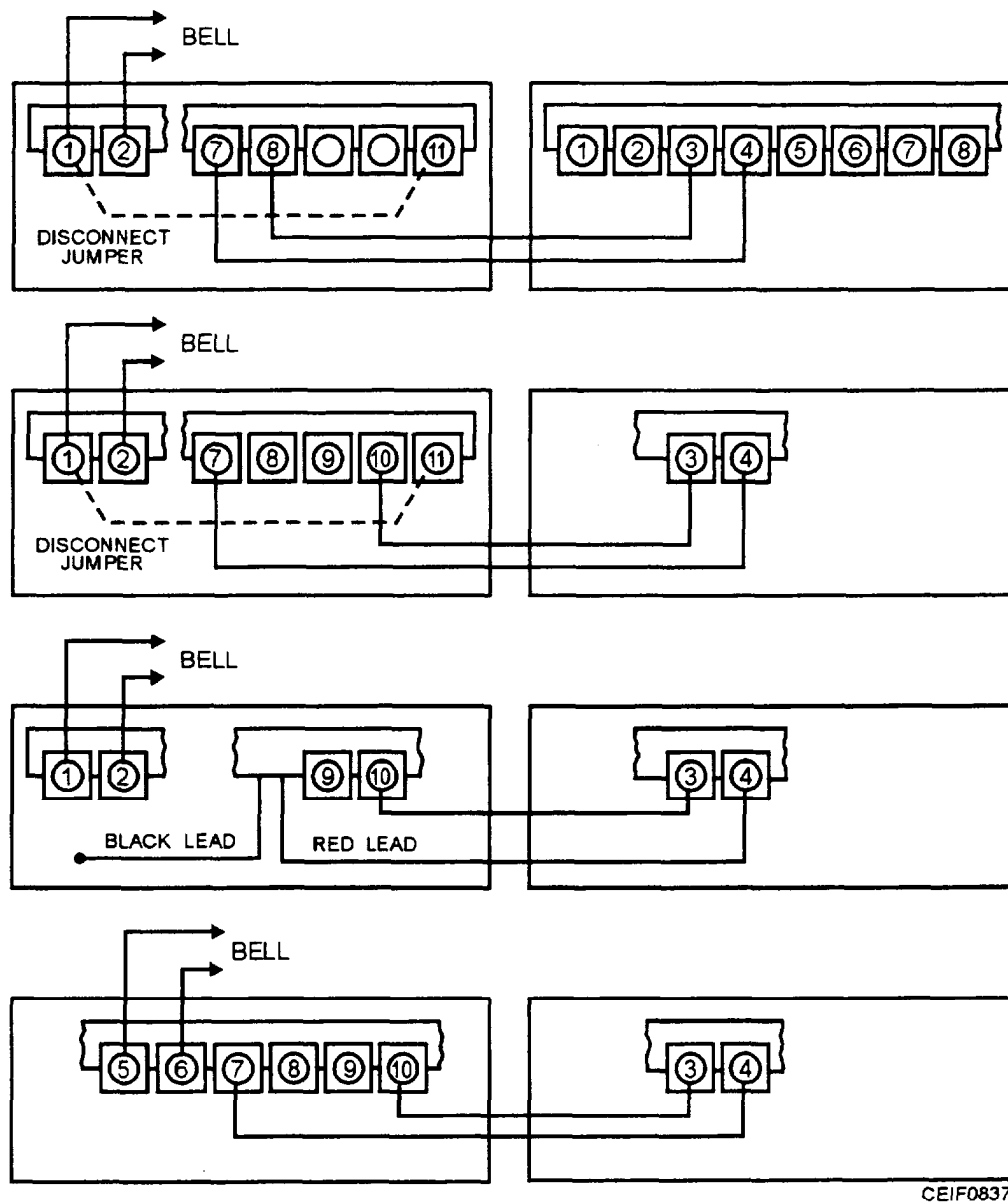

CEIF0837

Figure 8-37.—Preferred connections for a typical telephone dialer.

Where the contacts of a police-connect panel are needed for polarity reversal, the contacts may be used to provide a switched-voltage trigger for the dialer, as shown in figure 8-38. This hookup lets the panel's BELL TEST feature be used without causing any dialer transmission.

When using the bell output of an alarm panel as a switched-voltage trigger for the dialer, always run the

trigger wires directly from the dialer input terminals to control the panel terminals. Do not run the wires from the dialer inputs to the bell, horn, or siren locations; and do not route the sounding-device wires through the cabinet. Figure 8-39 shows the correct wiring for this hookup. In this hookup, dialer terminals 2, 5, and 6 are connected together within the dialer. This permits a simplified three-wire trigger connection from the control panel.

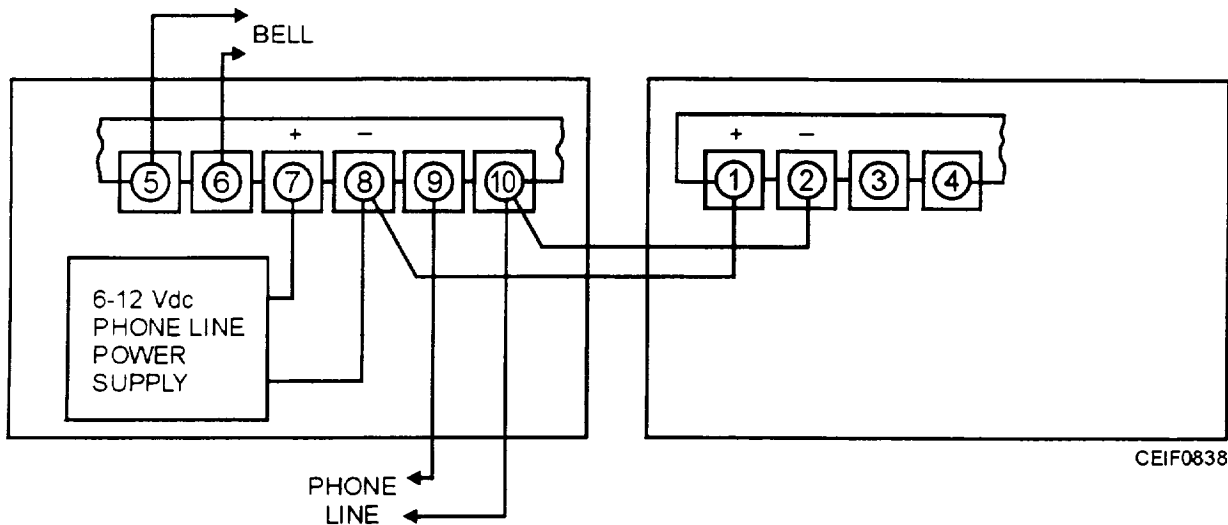

Figure 8-38.—A switched-voltage trigger connected to a telephone dialer.

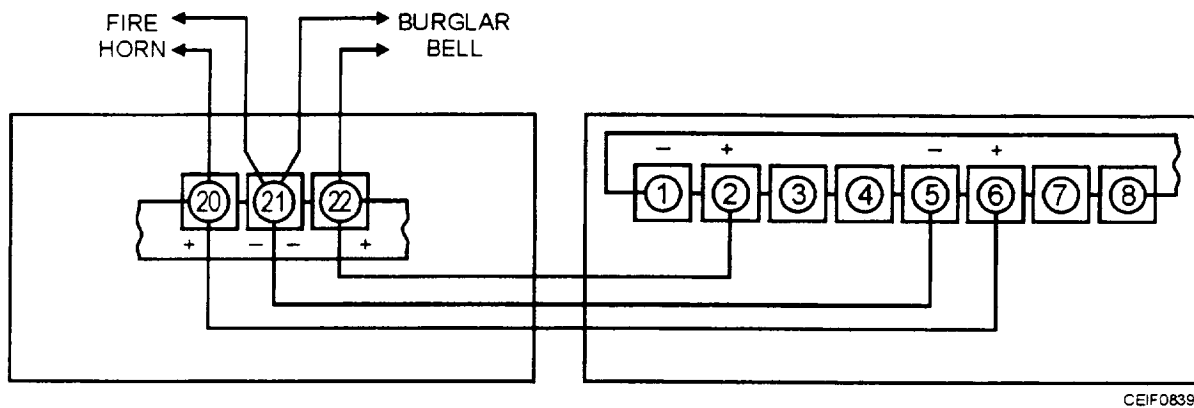

Figure 8-39.—Wiring diagram for a switched-voltage trigger.

APPENDIX I

REFERENCES USED TO DEVELOP THE TRAMAN

Although the following references were current when this TRAMAN was published, their continued currency cannot be assured. When consulting these references, keep in mind that they may have been revised to reflect new technology or revised methods, practices, or procedures. You therefore need to ensure that you are studying the latest references.

Chapter 1

Code of Federal Regulation, Title 29, Part 1926; Title 40, Parts 122 and 260-267; U. S. Government Printing Office, Washington, DC, 1997.

Department of the Navy Facility Category Codes, NAVFAC P--72, Naval Facilities Engineering Command, Alexandria, VA, 1984.

Environmental and Natural Resources Program Manual, OPNAVINST 5090.1 B, Chief of Naval Operations, Washington, DC, 1994.

Facilities Planning Guide, Volumes 1 and 2, NAVFAC P-437, Naval Facilities Engineering Command, Alexandria, VA, 1990.

Facilities Projects Manual, OPNAVINST 11010.20F, Chief of Naval Operations, Washington, DC, 1996.

Hazardous Material Control and Management (HMC&M), OPNAVINST 5090.1B, Chief of Naval Operations, Washington, DC, 1989.

Mishap Investigation and Reporting, OPNAVINST 5102.1C, Chief of Naval Operations, Washington, DC, 1989.

Naval Construction Force Occupational Safety and Health Program Manual, COMSECOND/COMTHIRDNCBINST 5100.1, Commander, Naval Construction Battalions, U.S. Pacific Fleet, Pearl Harbor, HI, and Commander, Naval Construction Battalions, U.S. Atlantic Fleet, Norfolk, VA, 1996.

Naval Mobile Construction Battalion Operations Officer's Handbook COMSECOND/COMTHIRDNCBINST 5200.2A, 1989.

Operation and Organizational Maintenance Manual, NAVFAC P-8-628-12, Naval Facilities Engineering Command, Alexandria, VA, 1984.

Procurement, Lease, and Use of Relocatable Buildings, OPNAVINST 11010.33B, Chief of Naval Operations, Washington, DC, 1988.

Seabee Crewleader's Handbook, The Civil Engineer Corps Officer's School (CECOS) CBC, Port Hueneme, CA, 1997.

Seabee Planner's and Estimator's Handbook, NAVFAC P-405, Naval Facilities Engineering Command, Alexandria, VA, 1994.

Table of Advanced Base Functional Components with Abridged Initial Outfitting List, OPNAV 41P3C, Chief of Naval Operations, Washington, DC, 1996.

Chapter 2

Blueprint Reading and Sketching, NAVEDTRA 12014, Naval Education and Training Program Management Support Activity*, Pensacola, FL, 1994.

Policy and Procedures for Project Drawing and Specification Preparation MIL-HDBK-1006/1A, Chesapeake Division, Naval Facilities Engineering Command, Washington DC, 1995.

Putnam, Robert, *Construction Blueprint Reading*, Englewood Cliffs, NJ, 1985.

Chapter 3

Croft, Terrell and Wilford I. Summers, *American Electrician's Handbook*, 12th ed., McGraw-Hill, New York, 1992.

Electric Power Distribution Systems Operations, NAVFAC MO-201, Naval Facilities Engineering Command, Alexandria, VA, 1990.

Electric Power Supply and Distribution, TM-5-811-1/AFM 88-9, Chapter 1, Department of the Army and Air Force, Washington, DC, 1984.

Facilities Engineering-Electrical Exterior Facilities, NAVFAC MO-200, Naval Facilities Engineering Command, Alexandria, VA, 1979.

Generator Set, Diesel Engine Drive, Tactical Skid Mount, NAVFAC P-8-628-12, Naval Facilities Engineering Command, Alexandria, VA, 1984.

Introduction to Alternating Current and Transformers, Navy Electricity and Electronics Training Series, Module 2, NAVEDTRA 172-02-00-91, Naval Education and Training Program Management Support Activity, Pensacola, FL, 1991.

Introduction to Solid-State Devices and Power Supplies, Navy Electricity and Electronics Training Series, Module 7, NAVEDTRA, 172-07-00-92, Naval Education and Training Program Management Support Activity, Pensacola, FL, 1992.

McPortland, J. F., and Brian J. McPortland, *National Electrical Code® Handbook*, 22nd ed., McGraw-Hill, New York, 1996.

National Electrical Code®, National Fire Protection Association, Quincy, MA, 1996.

Chapter 4

Application Guide for Capacitance Current Switching of AC High-Voltage Circuit Breakers Rated on a Symmetrical Current Basis, American National Standard Institute, Inc., ANSI C37.012-1979(R1989), The Institute of Electrical and Electronics Engineers, Inc., New York.

Electric Power Distribution Systems Operations, NAVFAC MO-201, Naval Facilities Engineering Command, Alexandria, VA, 1990.

Electric Power Supply and Distribution, TM-5-811-1/AFM 88-9, Chapter 1, Department of the Army and Air Force, Washington, DC, 1984.

IEEE Guide for Protection of Shunt Capacitor Banks, American National Standard Institute, Inc., ANSI C37.99, The Institute of Electrical and Electronics Engineers, Inc., New York, 1990.

Introduction to Alternating Current and Transformers, Navy Electricity and Electronics Training Series, Module 2, NAVEDTRA 172-02-00-91, Naval Education and Training Program Management Support Activity, Pensacola, FL, 1991.

Introduction to Solid-State Devices and Power Supplies, Navy Electricity and Electronics Training Series, Module 7, NAVEDTRA, 172-07-00-92, Naval Education and Training Program Management Support Activity, Pensacola, FL, 1992.

Kurtz, Edwin B., and Thomas M. Shoemaker, *The Lineman's and Cableman's Handbook*, 8th ed., McGraw-Hill, New York, 1996.

McPortland, J. F., and Brian J. McPortland, *National Electrical Code® Handbook*, 22nd ed., McGraw-Hill, New York, 1996.

National Electrical Code®, National Fire Protection Association, Quincy, MA, 1996.

Protective Headwear for Industrial Worker-Requirements, American National Standard Institute, Inc., ANSI 289.1, New York, 1986.

Rubber Insulating Blankets, American National Standard Institute, Inc., and American Society for Testing and Materials, ANSI/ASTM D1048-88, Philadelphia, 1988.

Rubber Insulating Gloves, American National Standard Institute, Inc., and American Society for Testing and Materials, ANSI/ASTM D120, Philadelphia, 1995.

Rubber Insulating Line Hose, American National Standard Institute, Inc., and American Society for Testing and Materials, ANSI/ASTM D1050-90, Philadelphia, 1990.

Specifications and Dimensions of Wood Poles, American National Standard Institute, Inc., ANSI O5.1, The Institute of Electrical and Electronics Engineers, Inc., New York, 1992.

Chapter 5

Croft, Terrell and Wilford I. Summers, *American Electrician's Handbook*, 12th ed., McGraw-Hill, New York, 1992.

Fink, Donald G., and H. Wayne Beaty, *Standard Handbook for Electrical Engineers*, 13th ed., McGraw-Hill, New York, 1993.

Introduction to Alternating Current and Transformers, Navy Electricity and Electronics Training Series, Module 2, NAVEDTRA 172-02-00-91, Naval Education and Training Program Management Support Activity, Pensacola, FL, 1991.

McPortland, J. F., and Brian J. McPortland, *National Electrical Code® Handbook*, 22nd ed., McGraw-Hill, New York, 1996.

National Electrical Code®, National Fire Protection Association, Quincy, MA, 1996.

Chapter 6

AM-2 Airfield Landing Mat and Accessories, NAVAIR 51-60A-1, Naval Air Systems Command, Washington, DC, 1996.

Definitive Designs for Naval Shore Facilities, NAVFAC P-272, Naval Facilities Engineering Command, Alexandria, VA, 1988.

Department of the Navy Physical Security and Loss Prevention, OPNAVINST 5530.14B. Chief of Naval Operations, Washington, DC. 1988.

Expeditionary Airfields, NAVAIR 51-35-7, Naval Air Systems Command, Washington, DC. 1984.

Facilities Engineering-Electrical Exterior Facilities, NAVFAC MO-200, Naval Facilities Engineering Command, Alexandria, VA, 1979.

General Requirements for Shorebased Airfield Marking and Lighting, NAVAIR 51-50AAA-2, Naval Air Systems Command, Washington, DC, 1990.

Informational Guide for Roadway Lighting, American Association of State Highway and Transportation Officials, Washington, DC.

Introduction to Fiber Optics, Navy Electricity and Electronics Training Series, Module 24, NAVEDTRA B72-24-00-92, Naval Educational Training Program Management Support Activity, Pensacola, FL, 1992.

Lighting and Marking Systems for Expeditionary Airfields, NAVAIR 51-40ABA-7, Naval Air Systems Command, Washington, DC, 1992.

McPortland, J. F., and Brian J. McPortland, *National Electrical Code[®] Handbook*, 32nd ed., McGraw-Hill, New York, 1996.

National Electrical Code[®]. National Fire Protection Association, Quincy, MA, 1996.

Standard Practice for Roadway Lighting, American National Standard Institute, Inc.. Illuminating Engineering Society, ANSI/IES RP8-1983(R1993), New York.

Chapter 7

Alerich, Walter N., *Electric Motor Control*, 5th ed., Delmar Publishers Inc., Albany, NY, 1993.

Code of Federal Regulation, Title 29, Part 1926, U. S. Government Printing Office, Washington, DC, 1997.

Croft, Terrell and Wilford I. Summers, *American Electrician's Handbook*, 12th ed., McGraw-Hill, New York, 1992.

Fink, Donald G., and H. Wayne Beaty, *Standard Handbook for Electrical Engineers*, 13th ed., McGraw-Hill, New York, 1993.

Introduction to Solid-State Devices and Power Supplies, Navy Electricity and Electronics Training Series, Module 7, NAVEDTRA, 172-07-00-92, Naval Education and Training Program Management Support Activity, Pensacola, FL: 1992.

McPortland, J. F., and Brian J. McPortland, *National Electrical Code[®] Handbook*, 22nd ed., McGraw-Hill. New York, 1996.

National Electrical Code[®], National Fire Protection Association, Quincy, MA, 1996.

Navy Occupational Safety and Health (NAVOSH) Program Manual, OPNAVINST 5100.23D, Chief of Naval Operations, Washington, DC, 1994.

Rosenberg, Robert and August Hand, *Electric Motor Repair*, 3d ed., Saunders College Publishing, Fort Worth, TX, 1987.

Chapter 8

Commercial Intrusion Detection Systems (IDS)DM.13.02, SN 0525-LP-64-6625, Naval Facilities Engineering Command, Alexandria, VA, 1986.

Introduction to Solid-State Devices and Power Supplies, Navy Electricity and Electronics Training Series, Module 7, NAVEDTRA, 172-07-00-92, Naval Education and Training Program Management Support Activity, Pensacola, FL, 1992.

Maintenance of Fire Protection Systems, NAVFAC MO-117, Naval Facilities Engineering Command, Alexandria, VA, 1989.

McPortland, J. F., and Brian J. McPortland, *National Electrical Code*[®] *Handbook*, 22nd ed., McGraw-Hill, New York, 1996.

National Electrical Code[®], National Fire Protection Association, Quincy, MA, 1996.

Traister, John E., *Design and Application of Security/Fire-Alarm Systems*, McGraw-Hill, New York, 1990.

* Effective 01 October 1996, the Naval Education and Training Program Management Support Activity (NETPMSA) became the Naval Education and Training Professional Development and Technology Center (NETPDTC).

INDEX

A

Advanced Base Functional Components (ABFC)

- assembly 32602, 1-5
- component P-25, 1-3
- facility 811 10R, 1-5
- index of facilities, 1-5
- NAVFAC P-437, 1-1, 1-2
- OPNAV 41P3, 1-1
- ordering, 1-5

Airfield lighting, 6-28

- circuits, 6-33
- condenser discharge system, 6-40
- fixtures and lamps, 6-39
- layout, 6-28
- systems, 6-28
- vault, 6-30

Airfield lighting systems, maintenance, 6-47

- routine, 6-47
- troubleshooting circuits, 6-48

Alarm systems, 8-1

- components, 8-9
- components, commercial/industrial 8-15
- control panel, 8-10
- entry detectors, 8-12
- equipment operation, new techniques, 8-6
- fire-alarm systems, 8-1
- installation, basic, 8-2
- installation in existing buildings, 8-4
- installation in existing buildings, new techniques, 8-6
- installation techniques, 8-1
- NEC[®] requirements, 8-2
- power supplies, 8-10
- techniques, new, practical application, 8-6

Area lighting systems, see Lighting, area systems

As-built drawings, see Construction drawings

C

Circuits, motor branch, see Motor branch

Conduit, bending, 5-15

- functions and safety, 5-15
- power benders, 5-15

Conduit, supports and installation, 5-1 8

- hangers and supports, 5-19
- location of supports, 5-18

Construction drawings, 2-2

- abbreviations and symbols, 2-5

Construction drawings-Continued

- as-built drawings, 2-4
- blueprint language, 2-4
- dimensions, metric, 2-13
- dimensions, modular, 2-12
- lines, types and weights, 2-4
- scale representation, 2-6
- schedules, 2-6
- working sketches, 2-4

Control circuits

- control symbols, 7-12
- general, 7-11

Controllers

- combination starters, 7-18
- push-button-station connections, 7-18
- start-stop station with a pilot light, 7-19
- testing component circuits, 7-17
- troubleshooting, 7-16

D

Drawings and specifications, definitions, 2-1

Drawings, construction, see Construction drawings

E

Electrical distribution systems configuration, 4-1

- loop/ring, 4-1
- network, 4-2
- primary selective, 4-3
- radial, 4-1

Electrical distribution systems maintenance, 4-33

- digital multimeters, 4-34
- interference elimination, 4-35
- maintenance of distribution equipment, 4-35
- measuring instrument precautions, 4-33
- safety equipment, 4-36

Electrical distribution systems overhead

- considerations
- equipment, 4-4
- capacitors, 4-15
- poles, 4-4
- protective/interrupting devices, 4-20
- transformers, 4-5
- pole locations, 4-3
- protective grounds, 4-25

- Electrical distribution systems underground
 - considerations
 - cable installation, 4-33
 - communication cables, 4-31
 - dangerous gases, 4-33
 - ducts and trenches, 4-29
 - manholes, 4-26
 - power cables, 4-31
 - pulling cable, 4-31
 - rigging, 4-32
 - risers and potheads, 4-30
- Electrical safety, 5-24
 - clothing and protective equipment, 5-27
 - fuses, 5-25
 - out-of-service protection, 5-26
 - portable electric tools, 5-25
 - safety color codes, 5-27
 - shock, 5-25
- Emergency/standby power, 3-1
 - generating plant operations, 3-6
 - generator installation, 3-4
 - generator selection, 3-1
 - power plant maintenance, 3-11
 - system design, 3-1
- Equipment grounding
 - fixed, 7-7
 - grounded circuit conductor, use of, 7-8
 - methods, 7-7
- Equipment troubleshooting, 7-24
- Excavations and shoring
 - excavations, 1-6
 - shoring, 1-6
- F**
- Fiber-optic measurements, 6-5
 - field measurements, 6-5
 - optical time domain reflectometry, 6-5
- Fiber-optic receivers, see Optical detectors
- Fiber-optic system installation, 6-4
- Fiber-optic system topology, 6-4
- Fiber-optical splices, mechanical and fusion 6-6
 - fusion, 6-8
 - glass or ceramic alignment tube, 6-6
 - multifiber, 6-8
 - rotary, 6-8
 - v-grooved, 6-7
- Fiber optics, 6-1
 - optical source properties, 6-1
 - semiconductor LEDs and LDs, 6-1
 - semiconductor material, 6-2
 - transmitters, 6-2
- Fire safety, 5-27
- Fire-alarm systems, see Alarm systems
- Floodlights, 6-17
 - aiming, 6-20
 - intensity calculations. 6-25
 - isofootcandle diagrams. 6-23
 - luminaires, selection of. 6-18
 - maintenance factor, 6-35
 - manufacturer's literature. 6-22
 - mounting height and spacing. 6-19
 - utilization graph. 6-25
- G**
- Generators, see Power generation
- Grounding equipment. see Equipment grounding
- H**
- Hazardous material, 1-15
- I**
- Interior wiring above grade, 5-4
 - branch circuits for grouped loads. 5-8
 - building wiring, 5-5
 - conductors, 5-8
 - conduit layout, 5-4
 - general provisions. 5-5
 - grounding, 5-5
 - individual branch circuits, 5-8
 - lighting and appliance branch circuit panelboards, 5-6
 - lighting and power systems, 5-6
 - motor branch circuits, 5-8
 - raceway system provisions, 5-5
 - services and feeders, 5-6
- Interior wiring below grade, 5-1
 - markings, 5-1
 - underfloor raceway systems, 5-3
 - wet and corrosive installations. 5-1
- L**
- Lighting. airfield, see Airfield lighting
- Lighting, area systems, 6-9
 - intensity, 6-9
 - intensity calculations. 6-15
 - luminaires, selection of, 6-10
 - manufacturer's literature. 6-12
 - mounting height and spacing. 6-10
 - street and area classifications, 6-9
- Lighting, security, see Security lighting
- M**
- Motor-branch circuits, 7-1
 - disconnecting means. motors, and controllers, 7-5

Motor-branch circuits-Continued
controllers, 7-5
fuses for motor-overload protection, 7-6
motor controller protection, 7-4
motor-feeder short-circuit and ground-fault protection, 7-3
overload devices, 7-7
overload protection, 7-6
protection of live parts, 7-7
several motors or loads, 7-3
short-circuit and ground-fault protection, 7-1
thermally protected motors, 7-7
Motor maintenance, 7-19
brush inspection, 7-23
cleaning, 7-23
commutator inspection, 7-23
lubrication, 7-19
periodic inspection, 7-22
records, 7-23
storage, 7-22
Motor start-up, 7-23

O

Optical detectors and fiber-optic receivers, 6-3
Optical fiber splices, see Fiber-optical splices

P

Power generation, 3-1
Project planning, 1-7
network analysis, 1-12
project planning package, 1-9

Q

Quality control
quality control plan, 1-15
resident officer in charge of construction (ROICC), 1-15

S

Safety, electrical, see Electrical safety
Safety, fire, see Fire safety
Security lighting, 6-26
alternate power sources, 6-27
area classification, 6-27
control, 6-27
Soldering and splicing, 5-20
solderless connectors, 5-20
splices, 5-21
Specifications, 2-2
Splices, see Fiber-optical splices

T

Testing electrical circuits, 5-10
circuit breakers and fuses, 5-12
defective receptacle, 5-10
defective switch, 5-10
ground terminal, 5-12
hot wire, 5-11
Timekeeping, 1-13
crew supervisor's report, 1-14
labor accounting system, 1-14
reporting, 1-14

Assignment Questions

Information: The text pages that you are to study are provided at the beginning of the assignment questions.

ASSIGNMENT 1

Textbook Assignment: "Construction Support," chapter 1, and "Drawings and Specifications," chapter 2.

- 1-1. The ABFC system was developed to provide support facilities to constantly changing tactical and strategic situations.
1. True
 2. False
- 1-2. Which of the following publications is a detailed, itemized line-item printout of the material in each ABFC?
1. NAVFAC P-405
 2. OPNAV 41P3B
 3. NAVFAC P-437
 4. NAVFAC P-72
- 1-3. Which of the following publications is the basic document that identifies the structures and supporting utilities of the ABFC system?
1. NAVFAC P-405
 2. OPNAV 41P3B
 3. NAVFAC P-437
 4. NAVFAC P-72
- 1-4. What Facilities Planning Guide gives you planning information, such as crew size, man-hours, land area, and fuel?
1. NAVFAC P-437, Vol. I, part III
 2. NAVFAC P-437, Vol. II
 3. NAVFAC P-72, Vol. II
 4. NAVFAC P-72, Vol. I
- 1-5. Which of the following ABFC series provides the facility code for an electrical power plant?
1. 200
 2. 700
 3. 800
 4. 900
- 1-6. The Construction Electrician Oriented Assemblies are grouped into which of the following numbered groupings?
1. 10,000 - 19,999
 2. 20,000 - 29,999
 3. 30,000 - 39,999
 4. 40,000 - 49,999
- 1-7. Verification of stock numbers is automatically done when components, facilities, or assemblies are ordered.
1. True
 2. False
- 1-8. The facility 811 10R of the mobilization component P25 has two fuel tanks for two 200 kW generators.
1. True
 2. False
- 1-9. Which of the following time frames is the duration of the construction standard classified as temporary?
1. less than 6 months
 2. 6 to 60 months
 3. 61 to 65 months
 4. 66 to 70 months

1-10. Days of construction duration are based on job requirements, optimum construction crew size, and full-material availability.

1. True
2. False

1-11. An assembly designated code "N" is suitable for which of the following temperate zones?

1. North
2. Tropical
3. South
4. Arctic

1-12. Which of the following facility recoverability codes indicate a total recoverability?

1. A
2. B
3. C
4. D

1-13. Trench-excavated materials must NOT be stored closer than which of the following minimum distances from the excavated trench edge?

1. 10 feet
2. 2 feet
3. 6 feet
4. 4 feet

1-14. When exiting or entering an excavated trench 4 feet or deeper, which of the following methods should be used?

1. Ladder
2. Stairway
3. Hoist
4. All of the above

1-15. Trenches of soft material must be shored if the depth exceeds what minimum depth?

1. 8 feet
2. 6 feet
3. 5 feet
4. 4 feet

1-16. Which of the following features should you be concerned with when determining the angle of slope or the material required for safe trench shoring?

1. Physical condition of the crew
2. Depth or cut of the trench
3. Anticipated changes in material from exposure to air, sun, and water
4. Both 2 and 3 above

1-17. The project package is the collection of all information required to plan, schedule, monitor, and execute the project.

1. True
2. False

1-18. Which of the following elements is the most critical part of the project package?

1. Field change documentation
2. Project history package
3. Project planning package
4. Inspection reports and material availability supply documentation

1-19. After the regiment divides the project into master activities and assigns the project to the battalion, the battalion breaks down the project into construction activities.

1. True
2. False

1-20. Network analysis is used for which of the following purposes?

1. As a management tool
2. As a method of planning
3. As a method of controlling a project
4. All of the above

1-21. As a management tool of network analysis, what advantage is there in seeing the interdependencies between events and the overall project?

1. Time restraints are easily adjustable to permit changes in the plan
2. Prevents unrealistic or superficial planning
3. Both 1 and 2 above
4. Enables the crew to complete the project on schedule

1-22. The identification of which of the following events is useful if the project completion date has to be advanced?

1. Critical path
2. Manpower scheduling
3. Material scheduling
4. Equipment scheduling

1-23. Which of the following disadvantages is common in network analysis of large projects?

1. Requirement for a computer
2. Chance for error is high when manually attempting to calculate events
3. Needs to be revised daily
4. Difficult to follow project progress on a day-to-day basis

1-24. Who is responsible for project planning?

1. Project crew leader
2. Project crew
3. Planning and estimating department
4. Project manager

1-25. Timekeeping and labor reporting are only important to NCF units.

1. True
2. False

1-26. Labor accounting records are mandatory for man-hours spent on various project functions.

1. True
2. False

1-27. The accountability for labor expended includes work performed by which of the following personnel?

1. Military
2. Civilian
3. Both 1 and 2 above

1-28. Quality control serves which of the following purposes?

1. Prevents discrepancies
2. Ensures the quality of workmanship
3. Ensures material meets specification requirements
4. All of the above

1-29. Who has responsibility for the quality of the construction project?

1. Crew leader only
2. The chain of command only
3. Crew leader and the chain of command
4. Project supervisor

- | |
|--|
| <ul style="list-style-type: none"> A. Personnel awareness B. Construction methods C. Quality control measures D. Work evaluation E. Training and equipment requirements |
|--|

Figure 1A

IN ANSWERING QUESTIONS 1-30 THROUGH 1-34, REFER TO FIGURE 1A, AND SELECT THE STEP THAT IS DESCRIBED IN THE QUESTION.

1-30. In what quality control development step would you address special requirements, such as training, hazardous material, or personnel safety protection?

- 1. A
- 2. B
- 3. C
- 4. D

1-31. In what quality control development step would you address concerns about project impact on equipment, tools, materials, labor, training, and safety requirements?

- 1. A
- 2. B
- 3. D
- 4. E

1-32. In what quality control development step would you address specialized training and special qualifications?

- 1. A
- 2. B
- 3. C
- 4. E

1-33. In what quality control development step would you brief all crew members about critical measurements and inspection items?

- 1. A
- 2. B
- 3. C
- 4. D

1-34. In what quality control development step would you judge that the work is being performed according to specifications?

- 1. B
- 2. C
- 3. D
- 4. E

1-35. Who has the final approving authority for NCF project field changes?

- 1. Quality control department
- 2. Quality control chief
- 3. Quality control officer
- 4. Resident officer in charge of construction

1-36. Tight work schedules and adverse working conditions are acceptable reasons for relaxation of safety standards.

- 1. True
- 2. False

1-37. Project concepts are normally developed by which of the following activity/activities?

- 1. NAVFACENGCOM
- 2. Local activities
- 3. Engineering Field Divisions
- 4. COMSECOND/COMTHIRD NCB

1-38. For which of the following reasons is/are supporting documentation for a construction project forwarded to NAVFACENGCOM?

1. Requirement validation
2. Technical adequacy of the design
3. Reasonable cost estimate
4. All of the above

1-39. Project activity quantities provide the basis for preparing which of the following estimates?

1. Material
2. Equipment
3. Manpower
4. All of the above

1-40. Which of the following information is NOT provided on a project bill of material statement?

1. Project stock numbers
2. Material quantities and line items
3. Identification of the location of where the material will be used
4. Description, vendor's name, and cost

1-41. Which of the following items contains a precise statement of quantities of material, equipment, and manpower required to construct a given project?

1. Activity estimate
2. Bill of material
3. Detailed estimate
4. Master activity

1-42. The specifications are arranged in the sequence in which the project will progress.

1. True
2. False

1-43. Construction drawings are the main basis for defining the required activities, measuring the quantities of material, and making accurate estimates.

1. True
2. False

1-44. Building projects are broadly divided into how many major phases?

1. One
2. Two
3. Three
4. Four

THIS SPACE LEFT BLANK
INTENTIONALLY.

- A. Working
- B. Shop
- C. Presentation
- D. Preliminary
- E. As built

Figure 1B

IN ANSWERING QUESTIONS 1-45 THROUGH 1-49, REFER TO FIGURE 1B, AND SELECT THE DRAWING THAT IS DESCRIBED IN THE QUESTION.

1-45. What drawing is prepared during the design phase?

- 1. A
- 2. B
- 3. C
- 4. D

1-46. What drawing shows the proposed building or facility in an attractive setting?

- 1. A
- 2. B
- 3. C
- 4. E

1-47. What drawing is developed after approval has been given for construction?

- 1. A
- 2. B
- 3. C
- 4. D

1-48. What drawing is supplied by manufacturers to show fabrication of building parts?

- 1. A
- 2. B
- 3. D
- 4. E

1-49. What drawing provides marked prints that indicate any construction deviations?

- 1. A
- 2. B
- 3. D
- 4. E

1-50. The drawing index is commonly divided into how many categories?

- 1. 10
- 2. 8
- 3. 6
- 4. 4

A. Border	G. Extension
B. Main object	H. Symbol section
C. Trim	I. Center
D. Dimension	J. Section
E. Broken	K. Invisible
F. Equipment	

Figure 1C

IN ANSWERING QUESTIONS 1-51 THROUGH 1-61, REFER TO FIGURE 1 C, AND SELECT THE TYPE OF LINE DESCRIBED BY THE QUESTION.

1-51. What construction drawing line is a light, continuous line along which the tracing is trimmed to square the sheet?

- 1. A
- 2. B
- 3. C
- 4. D

1-52. What construction drawing line is a heavy, continuous line that outlines the drawing?

- 1. A
- 2. B
- 3. C
- 4. D

1-53. What construction drawing line outlines the main wall lines on plans and sections?

1. A
2. B
3. C
4. D

1-54. What construction drawing line is drawn between extension lines with an arrowhead on each end?

1. A
2. B
3. C
4. D

1-55. What construction drawing line extends out from the edge or the point at which the dimension is to be determined?

1. E
2. F
3. G
4. H

1-56. What construction drawing line is a light, continuous, unbroken line used to show the location of transformers, panels, etc.?

1. E
2. F
3. G
4. H

1-57. What construction drawing line is used to shade surfaces shown on a drawing and by these means indicate the material used?

1. E
2. F
3. G
4. H

1-58. What construction drawing line is used in detailed drawings where only a section of the object is to be shown?

1. E
2. G
3. H
4. J

1-59. What construction drawing line is used to indicate an edge(s) that is/are hidden under some other part of the structure?

1. E
2. I
3. J
4. K

1-60. What construction drawing line is made up of alternating long and short dashes and is used to indicate the middle of an object?

1. E
2. I
3. J
4. K

1-61. What construction drawing line has arrowheads at each end that point in the direction in which the section is to be taken?

1. E
2. I
3. J
4. K

1-62. Where on a drawing would you find the meaning of any nonstandard symbol(s)?

1. Title block
2. Legend
3. Notes
4. Bill of material

1-63. Which of the following drawing scales is most commonly used to draw floor plans and elevations of construction projects?

1. 1 inch = 1 foot
2. 1/2 inch = 1 foot
3. 1/4 inch = 1 foot
4. 1/8 inch = 1 foot

ASSIGNMENT 2

Textbook Assignment: "Generators," chapter 3.

- 2-1. The National Electrical Code NEC® requires emergency generators and standby generator systems to be kept entirely separate of all other wiring and equipment.
1. True
 2. False
- 2-2. When designing an emergency generator backup system, which of the following must comply with electrical safety standards and codes?
1. Design
 2. Material
 3. Installation
 4. All of the above
- 2-3. When emergency power replaces normal power, which of the following load requirements is powered?
1. Full load
 2. Maximum capacity of the generator
 3. Selected loads
 4. 50% of normal power
- 2-4. A well-operated active base should have a minimum of which of the following (a) annual load factors and (b) power factors?
1. (a) 25% (b) 95%
 2. (a) 45% (b) 90%
 3. (a) 50% (b) 80%
 4. (a) 50% (b) 75%
- 2-5. Lighting circuits will be powered by 240 or 208 volt systems.
1. True
 2. False
- 2-6. When calculating a generator's electrical load, which of the following factors must be determined first?
1. Generator size
 2. Amount of ampere fluctuation in the system
 3. Connected load
 4. Both 2 and 3 above
- 2-7. The electrical power group maximum demand determines the size of which of the following pieces of equipment?
1. Generator
 2. Conductors
 3. Electrical apparatus
 4. All of the above
- 2-8. Which of the following terms is/are known as the ratio between the actual maximum demand and the connected load?
1. Group maximum demand
 2. Required supply demand
 3. Demand factor
 4. All of the above

2-9. The demand factor is usually less than 1.00 for which of the following reasons?

1. All load devices are seldom in use at the same time
2. All load devices will seldom reach maximum demand at the same time
3. Some load devices are usually larger than the minimum size needed and draw less than their rated load
4. All of the above

2-10. The total connected load of your repair shop is 60 kW, while the maximum demand is 40 kW. What is the demand factor?

1. 26%
2. 50%
3. 66%
4. 75%

2-11. Because of noise levels, fire hazards, and air circulation, regulations prevent you from locating a generator closer than a minimum of how many feet to a load?

1. 25
2. 20
3. 15
4. 10

2-12. A generator supplying power for an advanced base should be located at the

1. barracks site
2. edge of the base
3. points of small demand
4. points of large demand

2-13. Assume you have the responsibility of providing shelter for advanced base generators. Before the shelter can be constructed, you must give the builder all EXCEPT which of the following information?

1. Electrical power load
2. Number of generators to be sheltered
3. Size of the generators
4. Arrangement of the exhaust system

2-14. One way to get rid of excess engine heat in and around a generator set that is installed inside a building is by

1. providing suitable exits for exhaust gases
2. opening all the doors and hatches on the generator set
3. providing large louvered openings in the side of the generator set
4. providing large louvered openings in the building walls at the front and back of the generator set

2-15. When installing a generator exhaust system you must make sure that there are no more than three right-angle bends and that the piping is level.

1. True
2. False

2-16. Which of the following minimum generator exhaust pipe insulation temperature ratings should you install?

1. 500°
2. 1000°
3. 1200°
4. 1500°

2-17. Which of the following minimum generator ground terminal conductor size should you use for your generator installation?

1. 4 AWG
2. 6 AWG
3. 8 AWG
4. 10 AWG

2-18. The generator change board facilitates conversion of which of the following voltages?

1. 120/208 only
2. 240/480 only
3. 120/208 or 240/480
4. 120/208 or 240/416

2-19. Positioning of the voltage charge board connects two coils of each phase in series or in parallel.

1. True
2. False

2-20. When grounding a generator with a solid metal rod, you must ensure that the ground rod complies with which of the following requirements?

1. Is embedded below the permanent moisture level
2. Has a minimum diameter of 5/8 inch
3. Is driven to a minimum depth of 8 feet
4. Both 2 and 3 above

2-21. When grounding a generator with a grounding plate, you must ensure that the ground plate complies with which of the following requirements?

1. Has a minimum of 2 square feet of surface area
2. Is buried at a minimum depth of 2 1/2 feet
3. Both 1 and 2 above
4. Is a minimum of 6 inches thick

2-22. The NEC® states that if you are using a single ground rod to ground a generator set, it must have what maximum resistance to ground?

1. 25 ohms
2. 30 ohms
3. 35 ohms
4. 40 ohms

2-23. When installing multiple rods or plate electrodes, they should be installed at what minimum distance apart to meet NEC® requirements?

1. 5 feet
2. 6 feet
3. 8 feet
4. 10 feet

2-24. When installing a generator, which of the following tests will determine the required number of ground rods?

1. Conductivity
2. Static saturability
3. Earth resistance
4. Either 2 or 3 above

2-25. Which of the following factors must be determined before the installation of a generator feeder cable?

1. The size of conductors
2. Whether conductors will be direct burial, overhead, or installed in conduit
3. Proper voltage output
4. All of the above

2-26. Concerning generator cable loading, voltage drop should NOT exceed which of the following percentages for combined power and lighting loads?

1. 6%
2. 2%
3. 3%
4. 5%

2-27. Feeder conductors are capable of carrying which of the following percentage of rated generator amperes?

1. 100%
2. 125%
3. 150%
4. 200%

2-28. In a traffic area, what is the minimum burial depth for a cable?

1. 18 inches
2. 24 inches
3. 36 inches
4. 48 inches

2-29. Electrical cable may be covered with backfill (earth) that is free of rocks.

1. True
2. False

2-30. Which of the following duties are performed by personnel on generator watch?

1. Operating generator equipment
2. Maintaining generator equipment
3. Keeping the generator operating log
4. All of the above

2-31. In which of the following logs should the number of generator operating hours be recorded?

1. Generator fuel log
2. Generating station log
3. Generator inspection log
4. Generator maintenance log

2-32. One purpose for keeping a generator station log is to help determine when a particular piece of equipment needs preventive maintenance.

1. True
2. False

2-33. Which of the following requirements applies to oily cleaning rags in and around the generator spaces?

1. They must be stored outside
2. They must be stored in a wooden box that has wooden chips to absorb any oil
3. They must be stored in an oily waste container that has a cover
4. Either 2 or 3 above

2-34. As a generating plant supervisor, you are responsible for which of the following actions?

1. Supervising the activities of the operating personnel
2. Maintaining a continuous and adequate flow of electrical power
3. Supplementing your knowledge of the electrical plans and diagrams with an actual study of the generating station's systems
4. All of the above

2-35. Connecting an electric plant to a de-energized bus involves which of the following actions?

1. Starting the diesel engine and bringing it up to rated speed
2. Operating the switchboard controls
3. Both 1 and 2 above
4. Aligning the compressed air system on all electric-start engines

2-36. Which of the following documents contains the procedure that assures that all systems and controls are properly aligned for operation?

1. Prestart checklist
2. Operator maintenance manual
3. Intermediate maintenance manual
4. Shutdown checklist

2-37. Which of the following devices/switches adjusts the generator frequency?

1. Voltage regulator
2. Governor control
3. Synchronizing switch
4. Frequency switch

2-38. Which of the following actions should you take if the load of a single generator becomes so large that its rating is exceeded?

1. Secure the feed to unnecessary loads
2. Install a generator near the greatest load demand
3. Add another generator in parallel
4. Implement electrical ration hours

2-39. Before two generators can be operated in parallel, they must be brought into synchronism. When they are in synchronism, which of the following conditions must exist?

1. The terminal voltages must be equal
2. The frequencies must be equal
3. The voltage sequences must be in phase
4. All of the above

2-40. Which of the following terms describes the operation of getting a generator into synchronism?

1. Synchronizing
2. Balancing
3. Paralleling
4. Equalizing

2-41. Which of the following factors is a primary consideration in paralleling generator sets?

1. Proper division of the load
2. Proper division of the speed
3. Proper regulation of the speed
4. Both 2 and 3 above

2-42. Isochronous and speed droop are the two types of governor operations you should be concerned with when paralleling generators.

1. True
2. False

2-43. The isochronous governor will maintain which of the following generator actions?

1. Load regulation
2. Generator capacity
3. Output frequency
4. Load division

2-44. The number setting on the speed droop knob of a hydraulic governor indicates the percentage of droop.

1. True
2. False

2-45. On a solid-state electronic governor, when, if ever, are speed droop adjustments necessary?

1. As the load increases
2. As the load decreases
3. Both 1 and 2 above
4. No adjustments are necessary

2-46. When paralleling four generators in the droop mode, how many generator sets would be in the isochronous position?

1. One
2. Two
3. Three
4. Four

2-47. Concerning generator paralleling, it is preferable to have the frequency of which of the following generators slightly higher than the other generators?

1. The largest generator
2. The master generator
3. Either 1 or 2 above
4. The slave generator

2-48. Which of the following actions should you take if the phase sequence indicating light lights 1-2-3 on the master generator and 3-2-1 on the slave generator?

1. Commence paralleling operations
2. Interchange two of the load cables
3. Speed up the master generator
4. Slow down the slave generator

2-49. When the synchronizing lights blink ON and OFF simultaneously, this action indicates which of the following generator conditions?

1. Out of phase
2. In phase
3. Speed is too fast
4. Speed is too slow

2-50. The frequency at which the synchronizing lights blink ON and OFF together indicates which of the following circumstances?

1. The frequency of the master generator is out of sync
2. The frequency of the slave generator is out of sync
3. One generator is out of sync and one generator is in sync
4. The different frequency output between the two generators

2-51. Concerning generator paralleling operations using a synchroscope, you should adjust the frequency of the slave generator until the synchroscope pointer slowly rotates in (a) what direction and to (b) what position?

1. (a) Counterclockwise
(b) through the zero position
2. (a) Clockwise
(b) through the zero position
3. (a) Clockwise
(b) through the six o'clock position
4. (a) Counterclockwise
(b) through the six o'clock position

2-52. While paralleling using the synchronizing light, you should close the main circuit breaker during which of the following conditions?

1. When lamps are dark
2. When lamps are bright
3. When one lamp is bright and the other dark
4. Either 2 or 3 above

2-53. The master generator will absorb all load changes and maintain correct frequency unless it becomes overloaded or until its load is reduced to zero.

1. True
2. False

2-54. The power factor of an electrical load is determined by dividing the

1. true power by the peak power
2. true power by the apparent power
3. apparent power by the peak power
4. peak power by the average power

2-55. Capacitors may be used to improve the power factor of the system when the reduced power factor has been caused by effects of which of the following electrical factors?

1. Inductive reactance
2. Capacitive reactance
3. Pure resistance
4. All of the above

2-56. You can divide the reactive load between two generators by adjusting the

1. speed of the generators
2. voltage of the generators
3. speed droop of the generators
4. capacitance-reactance of the voltage regulators

2-57. Which of the following conditions may shut down the generator automatically and disconnect it from the main load?

1. Engine overspeed
2. High jacket water
3. Low lubricating oil pressure
4. All of the above

2-58. What is the purpose of installing both a mechanical clock and an electric clock at the power plant?

1. To ensure correct generator output frequency
2. To compensate for power failure
3. To ensure correct generator output voltage
4. To indicate improper division of reactive load

2-59. Which of the following is NOT a recommended time frame for the generator operator maintenance program?

1. Hourly
2. Daily
3. Weekly
4. Monthly

2-60. Of the following maintenance checks, which one is NOT performed by the operator?

1. Checking the level of the coolant
2. Greasing the fuel transfer pump
3. Draining water from the fuel tank
4. Adding oil to the crankcase

2-61. Which of the following is NOT a recommended time frame for the generator preventive maintenance program?

1. Weekly
2. Monthly
3. Quarterly
4. Semiannually

ASSIGNMENT 3

Textbook Assignment: "Electrical Distribution," chapter 4, pages 4-1 through 4-33.

- 3-1. What distribution system configuration is the simplest and least expensive to build?
1. Radial
 2. Loop
 3. Network
 4. Primary
- 3-2. The loss of which of the following components in a radial distribution system will result in an outage on all loads served by the feeder?
1. Cable
 2. Primary supply
 3. Transformer
 4. Each of the above
- 3-3. Service to a radial distribution system can be improved by the installation of which of the following components?
1. Hand reset circuit breakers
 2. Automatic circuit breakers
 3. Auto-protected transformers
 4. Additional lightning protective devices
- 3-4. In the loop distribution system, how many sectionalizing breakers are installed near the distribution transformers to open each primary cable?
1. One
 2. Two
 3. Three
 4. Four
- 3-5. A network system and a radial system differ in what respect?
1. The type of transformers used
 2. The type of fuses used
 3. The way the secondaries are connected
 4. The way the primaries are connected
- 3-6. If a new primary feeder system must be flexible because of probable future growth, what type of system should you recommend?
1. Network
 2. Radial
 3. Loop
- 3-7. Which of the following books is an excellent source of information on electrical distribution systems?
1. *American Electrician's Handbook*
 2. *Standard Handbook for Electrical Engineers*
 3. *The Lineman's and Cableman's Handbook*
 4. *National Electrical Code®*

3-8. Which of the following concerns may be addresssd when installing a new power distribution addition?

1. Select the straightest and shortest route
2. Route the system in the general direction of future load demands
3. Make the system readily accessible for construction, inspection and maintenance
4. All of the above

3-9. What type of pole is considered to be the most economical for power line support?

1. Fiberglass
2. Steel
3. Wood
4. Reinforced concrete

3-10. Which of the following means of disposal should you use for a creosote-treated wooden pole?

1. Burning
2. EPA approved landfill
3. Burying
4. Either 2 or 3 above

3-11. Which of the following means is used to classify a wooden pole?

1. Length
2. Circumference at the top of the pole
3. Circumference measured 6 feet from the bottom of the pole
4. All of the above

3-12. Lightning arresters for a distribution transformer should be located between which of the following areas?

1. Primary mains and fuse cutouts
2. Primary and secondary sides of the transformer
3. Fuse cutouts and the secondary bushings of the transformer
4. Secondary side of the transformer and the service drop

3-13. Which of the following types of distribution transformers require the installation of external protective devices?

1. Conventional
2. Self-protected
3. Both 1 and 2 above
4. Completely self-protected

3-14. What feature does the completely self-protected (CSP) type of transformer have that differs from the other types?

1. A built-in circuit breaker
2. A fuse cutout mounted to the outside of the transformer
3. A beeper that sounds when there's trouble within the transformer
4. Two tap changers: one primary and one secondary

3-15. How much oil should be put in a transformer?

1. Fill up to the rim
2. Standard 5 gallons
3. Fill up to the oil-level line
4. Add as much oil as needed to cover the secondary coils only

- | |
|--|
| A. Liquid-immersed water-cooling
B. Liquid-immersed self-cooling
C. Air-blast cooling
D. Self-air cooling |
|--|

Figure 3A

IN ANSWERING QUESTIONS 3-16 THROUGH 3-19, REFER TO FIGURE 3A, AND SELECT THE TRANSFORMER DESCRIBED IN THE QUESTION.

3-16. This transformer has a cooling method that cools by surrounding air at atmospheric pressure.

1. A
2. B
3. C
4. D

3-17. This transformer has a cooling method that has the core and windings encased in a metal enclosure through which air is circulated by a blower.

1. A
2. B
3. C
4. D

3-18. This transformer has a cooling method that has water circulated through coils and carries away the heat from the oil as it rises in the tank.

1. A
2. B
3. C
4. D

3-19. This transformer has a cooling method that has its coils and core completely immersed in transformer oil.

1. A
2. B
3. C
4. D

3-20. Which of the following types of transformers would you find in a major substation?

1. Completely self-protected (CSP)
2. Current
3. Air-blast-cooling
4. Auto

3-21. Old transformers may contain which, if any, of the following dangerous chemical elements?

1. CO_2R_2
2. PCBs
3. CO_2H_2
4. None

3-22. Which of the following safety precautions will protect you when handling Askarel® oil?

1. Wearing impermeable gloves
2. Wearing splashproof goggles
3. Properly ventilating the work space
4. All of the above

3-23. When removing Askarel® oil that is contaminated with PCBs, an air respirator may be necessary,

1. True
2. False

- 3-24. The ground resistance between the ground wire and the ground distribution neutral should read no more than how many ohms?
1. 10
 2. 25
 3. 50
 4. 66
- 3-25. Which of the following actions will lower ground resistance?
1. Drive additional ground rods
 2. Connect additional ground rods in parallel
 3. Use larger ground rods
 4. All of the above
- 3-26. Which of the following terminal markings is correct for a transformer with additive polarity?
1. H2H1-X1X2
 2. H1H2-X2X1
 3. Both 1 and 2 above
 4. H1H2-X1X2
- 3-27. Transformers larger than 100 kVA are usually mounted on which of the following places?
1. Pad or platform
 2. Pole below the secondary mains
 3. Pole above the secondary mains
 4. Cluster mount above the primary mains
- 3-28. At what height above the base of the pole are ground wires required to be covered with plastic or wood molding?
1. 6 feet
 2. 8 feet
 3. 10 feet
 4. 12 feet
- 3-29. When determining the size of a transformer for a certain load, how should you calculate the approximate maximum demand load?
1. Divide the total maximum connected load by the demand factor
 2. Divide the demand factor by the total maximum connected load
 3. Multiply the total maximum connected load by the demand factor
 4. Multiply the total maximum connected load by the power factor
- 3-30. Power capacitors are used in distribution systems to supply what electrical factor?
1. Capacitive reactance
 2. Inductive reactance
 3. Reactive voltamperes
 4. Impedance
- 3-31. When voltage and current waves do not have the same direction at the same instant they are said to be
1. in phase
 2. out of phase
 3. lagging phase
 4. leading phase
- 3-32. When current and voltage in a circuit rise and fall in value together, in the same direction at the same instant, what is the power factor in that circuit?
1. Zero
 2. .75
 3. .80
 4. 1.0

3-33. What is the unit of measurement for apparent power?

1. ohms
2. Watts
3. Voltamperes
4. Watts per voltamperes

3-34. What is the cause of low power factor in an electrical circuit?

1. High load resistance
2. Low impedance
3. High amount of inductance
4. Low inductive reactance

3-35. Which of the following electrical components is used for power factor correction?

1. Booster transformer
2. Filter resistor
3. Inductive filter
4. Synchronous motor

3-36. What device is most economical to correct a low power factor?

1. Synchronous motor
2. Capacitor
3. Inductor
4. Filter resistor

3-37. Capacitance is the opposite of what electrical factor?

1. Resistance
2. Impedance
3. Conductance
4. Inductance

3-38. What happens when a capacitor is operated below its rated frequency?

1. kvar rating is reduced
2. kvar rating is increased
3. Current is reduced
4. Voltage is reduced

3-39. Other than for power factor correction, a capacitor in an electrical distribution system can be used for which of the following purposes?

1. Current boost during heavy loads
2. Voltage boost during heavy loads
3. Current boost when the power factor is low
4. Voltage boost when the power factor is low

3-40. After a capacitor has been disconnected from an energized circuit, how long should you wait before connecting it back to the circuit?

1. 1 hour
2. 1 1/2 hours
3. 5 minutes
4. 15 minutes

3-41. Before shorting the terminals of a capacitor, which of the following precautions should you follow?

1. Wait 15 minutes
2. Make sure the capacitor voltage is zero
3. Make sure the terminals are grounded to earth
4. All of the above

3-42. When a capacitor is installed to switch a circuit on and off, the switching device should be rated at what percentage of the capacitor rating?

1. 80%
2. 100%
3. 125%
4. 135%

3-43. Capacitors rated at 600 volts or more with built-in discharge resistors are required by the *National Electrical Code*® to be discharged in 5 minutes to what minimum voltage?

1. 5 volts
2. 15 volts
3. 50 volts
4. 100 volts.

3-44. Primary capacitors used in distribution systems are rated at what minimum voltage?

1. 600 volts
2. 1,000 volts
3. 2,400 volts
4. 3,000 volts

3-45. Capacitors installed in an open-rack configuration are normally connected in which of the following manners?

1. Delta
2. Parallel
3. Series
4. Wye

3-46. After a capacitor bank has been installed, it should be inspected and checked at what minimum interval?

1. Once a week
2. Once a month
3. Twice a month
4. Once a year

3-47. Maintenance for an oil switch operating a capacitor bank should be performed after the switch has been operated on and off for what maximum number of times?

1. 500
2. 1,500
3. 2,500
4. 3,000

3-48. A surge arrester performs which of the following functions?

1. Allows follow-up currents to flow to ground
2. Drains off excess voltage through the capacitor banks
3. Drains off excess voltage to ground
4. Drains off excess current to ground

3-49. Enclosed cutouts are designed to operate at what maximum voltage?

1. 2,400 volts
2. 5,000 volts
3. 7,200 volts
4. 10,000 volts

3-50. Primary fuse links with no electrical load must withstand what minimum pound pull?

1. 5
2. 10
3. 15
4. 25

3-51. For an electrical distribution system to be safe, distribution transformers are protected against the slightest overload.

1. True
2. False

3-52. What is the minimum number of linemen required to open a ganged three-way switch?

1. One
2. Two
3. Three
4. Four

3-53. Opening a disconnect switch in a circuit where current is flowing could cause which of the following conditions?

1. Circuit overload
2. Circuit overcurrent
3. Circuit overvoltage
4. Short circuit

3-54. The oil in an oil switch serves which of the following purposes?

1. Lubricant for the moving parts
2. Extinguishing agent for the electrical arc
3. Coolant during heavy loads
4. Insulator for the live parts

3-55. When an oil switch opens a circuit automatically because of an overload or short circuit, which of the following components should be installed with the oil switch?

1. Fuse
2. Magnetic relay
3. Overload relay
4. Trip coil

3-56. What is the purpose of a recloser in a distribution circuit?

1. It opens the circuit in case of a fault, locks the switch in the open position, then recloses the circuit immediately after the fault is corrected
2. It recloses an open circuit automatically after the circuit has the sufficient amount of power
3. It recloses an open circuit only when it is signaled remotely by the substation operator to close
4. It opens the circuit in case of a temporary fault and recloses the circuit a few times until the fault is corrected

3-57. A recloser could be set to re-close at what maximum number of times?

1. One
2. Five
3. Three
4. Four

3-58. Which of the following statements describes a difference between a fuse link and a recloser?

1. A fuse link has a lower ampere rating
2. A fuse link has a higher voltage rating
3. A fuse link can distinguish between temporary and permanent fault
4. A fuse link cannot distinguish between temporary and permanent fault

- 3-59. When a de-energized line runs parallel to an unloaded energized line, which of the following electrical characteristics could be picked up?
1. Capacitance
 2. Static current
 3. Static voltage
 4. Induced voltage
- 3-60. When a de-energized line runs parallel to a loaded energized line, which of the following electrical characteristics could be picked up?
1. Capacitance
 2. Static current
 3. Static voltage
 4. Induced voltage
- 3-61. When working with de-energized power lines, which of the following precautions is the best way to avoid accidentally energizing the lines?
1. Post a watchstander by the power switch
 2. Put a lock on the power switch
 3. Install short circuiting and grounding: leads to the lines
 4. All of the above
- 3-62. What is the maximum recommended distance between manholes?
1. 400 feet
 2. 500 feet
 3. 600 feet
 4. 1,000 feet
- 3-63. What is the smallest allowable size of a manhole?
1. 2- by 3-foot
 2. 3- by 4-foot
 3. 5- by 7-foot
 4. 6- by 6-foot
- 3-64. When determining the size of manhole to be used for transformers, how many cubic feet should you allow per kilovoltampere rating of the transformer?
1. 1 to 1 1/2
 2. 2 to 3
 3. 3 1/2 to 4
 4. 4 1/2 to 5
- 3-65. Uppermost ducts installed on a manhole should have a minimum of which of the following depths from the ground?
1. 18 inches
 2. 30 inches
 3. 3 feet
 4. 4 feet
- 3-66. Communication cables installed underground should be buried at what minimum depth?
1. 18 inches
 2. 2 feet
 3. 3 feet
 4. 30 inches
- 3-67. Before you completely bury an underground cable, what should you place above the cable?
1. Concrete markers
 2. Plastic streamers
 3. Three-inch layer of sand
 4. Each of the above
- 3-68. A 600-volt direct burial cable should be installed at what minimum depth?
1. 12 inches
 2. 18 inches
 3. 24 inches
 4. 30 inches

3-69. Which of the following means should be used for water drainage from a manhole?

1. Ducts that slope down from the manhole
2. Pumps installed in the manhole
3. A central drain hole, a dram line, and a sump for the manhole
4. A series of drainage holes bored on the deck of the manhole

3-70. When a duct line is set in concrete, there should be a minimum of how many inches of concrete around each line of duct?

1. 6
2. 9
3. 3
4. 12

3-71. Which of the following methods is used to clean ducts?

1. Wiping
2. Vacuuming
3. Rodding
4. Each of the above

3-72. You are pulling multiple cables through a duct. You should pull the cable at what rate?

1. 25 feet per minute
2. 35 feet per minute
3. 50 feet per minute
4. 75 feet per minute

3-73. Before you enter an underground structure, which of the following people must certify it as being safe?

1. Safety chief
2. Safety officer
3. Confined space manager
4. Commanding officer

ASSIGNMENT 4

Textbook Assignment: "Electrical Distribution," chapter 4, pages 4-33 through 4-37, "Interior Wiring," chapter 5, and "Fiber Optics and Lighting," chapter 6, pages 6-1 through 6-8.

- 4-1. An ammeter has which of the following electrical characteristics?
1. High internal resistance
 2. High power consumption
 3. Low internal resistance
 4. Low voltage rating
- 4-2. When an ammeter is connected across a voltage source, which of the following conditions will occur?
1. The circuit will be overloaded
 2. The circuit will consume excessive power
 3. The ammeter will be damaged
 4. The ammeter will read the current in the reverse direction
- 4-3. Before breaking a circuit connection for an ammeter, what should be your first step?
1. Set the meter at its highest range
 2. Energize the circuit
 3. De-energize the circuit
 4. Set the meter at its lowest range
- 4-4. When taking measurements on a direct-current circuit you should connect the ammeter to the correct polarity.
1. True
 2. False
- 4-5. Before connecting an ohmmeter into a circuit, what step should you do first?
1. Place the meter to its highest range
 2. Check the polarity of the meter
 3. Make sure current is in the circuit
 4. Make sure there is no voltage in the circuit
- 4-6. Before placing the test leads of an ohmmeter into the terminals of a capacitor, what step should you do first?
1. Ground the case of the capacitor
 2. Charge the capacitor
 3. Discharge the capacitor
 4. Ground the ohmmeter
- 4-7. You should not use a low-voltage megger to test high-voltage insulation breakdown for which of the following reasons?
1. The megger will be damaged
 2. The megger will not read accurately
 3. The insulation will be damaged
 4. The megger will not indicate any reading
- 4-8. To dry a wet digital multimeter, you should use low-pressure clean air at what maximum pounds per square inch (psi)?
1. 10
 2. 20
 3. 25
 4. 30

4-9. Cross-modulation interference is caused by which of the following conditions?

1. Ionized air in the vicinity of power lines
2. Localized excessive voltage stress
3. Corroded connections in distribution lines
4. Cracked power line insulation

4-10. Spark-discharge interference is caused by which of the following conditions?

1. Ionized air in the vicinity of power lines
2. Corroded connection in distribution lines
3. Cracked power line insulation
4. Both 2 and 3 above

4-11. When working on distribution lines, what action should you take to protect your high-voltage rubber gloves?

1. Wear cotton gloves over them
2. Avoid handling sharp objects
3. Wear leather gloves over them
4. Use them only on de-energized circuits

4-12. How often should rubber gloves be given an air test?

1. Yearly
2. Monthly
3. Weekly
4. Each day, before using the glove

4-13. What action should you take to protect rubber gloves from mechanical damage?

1. Leave the rubber gloves inside the cotton gloves
2. Leave the rubber gloves inside the leather gloves
3. Store the gloves inside a canvas bag
4. Store the gloves in dry storage

4-14. Besides mechanical damage, rubber gloves should be protected from which of the following conditions?

1. Moisture
2. Dryness
3. Sunlight
4. Chemical exposures

4-15. A rubber insulating insulator hood is used to cover what distribution system component?

1. Bare conductor
2. Suspension insulator
3. Strain insulator
4. Post insulator

4-16. If a direct burial cable is installed underneath a four-inch concrete slab, it should be buried at what minimum depth?

1. 6 inches
2. 18 inches
3. 24 inches
4. 30 inches

4-17.If a direct burial cable is installed underground without covering, it should be buried at what minimum depth?

1. 6 inches
2. 12 inches
3. 18 inches
4. 24 inches

4-18.Type UF cable can be used in what location?

1. A service entrance
2. Embedded in concrete
3. A wet location
4. In a storage-battery room

4-19. An electrical wiring system installed in an underfloor raceway should have what maximum voltage?

1. 110 V
2. 220 V
3. 440 V
4. 600 V

4-20.Underfloor raceway ducts should be filled with conductors up to what maximum percentage of its cross sectional area?

1. 90%
2. 80%
3. 50%
4. 40%

4-21.For general installation, underfloor raceways should be installed at least how many inch(es) below the surface of a floor?

1. 1 inch
2. 2 inches
3. 1/2 inch
4. 3/4 inch

4-22. If an interior wiring system is not installed underground, where is the starting point located?

1. At the service entrance
2. At the watt-hour meter
3. At the panel board
4. At the service drop

4-23. Power feeders should never be suspended less than what minimum distance above a walkway?

1. 10 feet
2. 12 feet
3. 18 feet
4. 20 feet

4-24.Communications circuits should be installed in what enclosure?

1. In the same enclosure with light circuits
2. In the same enclosure with power circuits
3. In an enclosure all by itself

4-25.Conductors installed in raceways that are No. 8 AWG or larger should be configured in which of the following ways?

1. Solid
2. Stranded
3. Securely fastened to the raceway
4. Grounded to the raceway

4-26. If an overcurrent device or circuit breaker is located in a panel board and rated at 80 amperes, it should have a load that does not exceed how many amperes?

1. 60
2. 64
3. 80
4. 100

4-27. The insulation of an equipment-grounding conductor should have what outer color?

1. White
2. Green with yellow stripes
3. Gray
4. Gray with yellow stripes

4-28. You have a conductor with black insulation that you want to use as an equipment ground conductor. What should you do with the wire before installing it?

1. Put a yellow stripe on the insulation
2. Color the exposed insulation white
3. Mark the exposed insulation with gray tape
4. Strip the insulation from the entire exposed length of the wire

IN ANSWERING QUESTIONS 4-29 AND 4-30, REFER TO TABLE 5-2 IN CHAPTER 5.

4-29. When a No. 2 AWG copper wire is installed vertically in a multistory building, it should be supported at what intervals?

1. Every 200 feet
2. Every 180 feet
3. Every 100 feet
4. Every story

4-30. When a No. 6 copper conductor is installed vertically in a multistory building and supported by the deflection method, it should be supported at what intervals?

1. Every 100 feet
2. Every 200 feet
3. Every 50 feet
4. Every 20 feet

4-31. An electrical circuit can be tested safely and inexpensively using which of the following test equipment?

1. Digital multimeter
2. Line-voltage tester
3. Light bulb tester
4. Neon tester

4-32. When you use a power bender, what procedures should you follow?

1. The same procedures as manual benders
2. The procedures recommended by the conduit manufacturer
3. The procedures recommended by the bender manufacturer
4. The same procedures as any other power bender

IN ANSWERING QUESTION 4-33, REFER TO TABLE 5-3 IN CHAPTER 5.

4-33. When bending with power benders and the manufacturer's chart is not available, what should be the minimum stub length of a 1-inch conduit?

1. 1 7/8 inches
2. 2 3/8 inches
3. 10 inches
4. 13 inches

4-34. Before turning the motor of a power bender to bend a conduit, what safety check should you make?

1. Make sure the power is on
2. Make sure that the bender is perfectly leveled to the floor
3. Make sure the lock pins are properly engaged
4. Make sure the conduit is g-rounded

4-35. A conduit run from one outlet to the next should only have what maximum number of bends?

1. Seven
2. Six
3. Five
4. Four

4-36. Wooden plugs should never be used as anchors for which of the following reasons?

1. They cure in a short time
2. They might stain the wall
3. They eventually loosen in the hole
4. Each of the above

IN ANSWERING QUESTION 4-37,
REFER TO TABLE 5-4 IN CHAPTER 5.

4-37. You are installing two 1/2 inch conduit runs parallel to each other. What is the proper spacing between the conduits?

1. 1 5/8 inches
2. 7/8 inch
3. 5/8 inch
4. 25/32 inch

IN ANSWERING QUESTION 4-38,
REFER TO TABLE 5-5 IN CHAPTER 5.

4-38. A 1 1/2-inch rigid conduit installed in a straight run should be supported at what maximum interval?

1. 10 feet
2. 12 feet
3. 14 feet
4. 16 feet

4-39. Which of the following wire splices is simple to make?

1. Western Union
2. T-tap
3. Portable chord splice
4. Pigtail

4-40. Which of the following wire splices is the most difficult to make?

1. Western Union
2. T-tap
3. Portable chord splice
4. Pig tail

4-41. When soldering wires, you should not leave the unsoldered splice exposed to the air for a long period of time for which of the following reasons?

1. The exposed splice will oxidize
2. The exposed wire will collect dirt
3. The exposed splice will collect moisture
4. All of the above

4-42. What means should you use to cool a soldered splice?

1. Dip it in water
2. Blow on it
3. Allow it to cool naturally
4. Apply a damp rag to it

4-43. Which of the following tools should you use to remove a fuse from a switch box?

1. Electrician's pliers
2. Needle nose pliers
3. Fuse puller
4. Each of the above

4-44. Which of the following methods should you use to replace a fuse?

1. Install the fuse first into the line side of the fuse clip, then into the load side
2. Install the fuse into the load side and line side fuse clips at the same time
3. Install the fuse first into the load side of the fuse clip, then into the line side
4. Each of the above

4-45. Which of the following statements is correct about the use of portable electric tools?

1. Make sure all tools you use have a third plug
2. Make sure all tools are double insulated
3. Make sure all tools are grounded
4. Make sure you use GFCI on any tool

IN ANSWERING QUESTIONS 4-46 AND 4-47, REFER TO TABLE 5-6 IN CHAPTER 5.

4-46. What OSHA safety color code is used to indicate a cutting device?

1. Purple
2. Orange
3. Yellow
4. Red

4-47. What OSHA safety color code is used to designate emergency stop switches?

1. Orange
2. Yellow
3. Red
4. Green

4-48. What is the very first thing you should do when you discover a fire in your work place?

1. Make a reasonable effort to put out the fire
2. Call the fire department
3. Pull the fire alarm and alert all workers in the work place
4. Contact your immediate supervisor

4-49. A fire in an electric motor is designated as what type of fire?

1. Class A
2. Class B
3. Class C
4. Class D

4-50. Fire in a paint locker should be extinguished with what which of the following agents?

1. Water
2. Carbon dioxide
3. Dry chemicals
4. Both 2 and 3 above

4-51. The best extinguishing agent for electrical fires is water.

1. True
2. False

4-52. What fiber-optic device converts electrical signals to optical signals?

1. Transducer
2. Converter
3. Transmitter
4. Inverter

4-53. What fiber-optic transmitter component receives incoming electrical signals?

1. Receiver
2. Source drive circuit
3. Coupler
4. Interface circuit

4-54. What is the difference between a semiconductor LED and an LD?

1. An LED emits coherent light while an LD does not
2. An LED has a fixed-phase relationship while an LD lacks this relationship
3. An LED is more economical to operate than an LD
4. An LED is more expensive to operate than an LD

4-55. Semiconductor lasers emit light at a spread of what angle?

1. 2 to 4 degrees
2. 5 to 7 degrees
3. 10 to 15 degrees
4. 16 to 20 degrees

4-56. Which of the following is the most common material used to produce a semiconductor?

1. Silicon
2. Indium
3. Aluminum
4. Phosphorus

4-57. Light from a laser is produced through what process?

1. Spontaneous emission
2. Simulated emission
3. Simultaneous emission
4. Stimulated emission

4-58. Which of the following statements is correct concerning electric energy in the operation of an LED and an LD?

1. All electrical energy is converted to optical energy
2. A small amount of electrical energy is converted to heat energy
3. A substantial amount of electrical energy is converted to optical energy
4. A substantial amount of electrical energy is converted to heat energy

4-59. What component is used to more efficiently couple light from a light source to an optical connector?

1. Optical pigtail
2. Coupler
3. Lens
4. Transducer

4-60. Which of the following fiber-optic components converts the weakened and distorted optical signal back into an electrical signal?

1. Transmitter
2. Amplifier
3. Receiver
4. Coupler

4-61. Which of the following is the purpose of an optical detector?

1. To generate an optical pulse proportional to the input current
2. To convert an optical signal into an electrical signal
3. To convert an electrical signal into an optical signal
4. To amplify the optical output signal

4-62. What type of fiber-optic link consists of two simple point-to-point links transmitting in opposite directions?

1. Simplex
2. Composite
3. Full duplex
4. Opposite

4-63. What instrument is recommended for taking field measurements on an installed optical fiber cable that is 100 feet long?

1. Optical loss test reflectometer
2. Digital multimeter
3. Optical time domain reflectometer
4. Optical time domain refractometer

4-64. What fiber-optic cable splice is considered a permanent splice?

1. Adhesive splice
2. Mechanical splice
3. Welded splice

4-65. In a V-groove splice, what material or component completes the assembly process by bonding the ends of the fiber-optic cable?

1. The substrate
2. The flat spring
3. The transparent adhesive
4. The alignment sleeve

4-66. Which of the following techniques is the most popular technique used for fusion splicing?

1. Carbon-dioxide-laser fusion
2. Nichrome-wire fusion
3. Electric-arc fusion
4. Gas-flame fusion

4-67. What was the first heating element used for fusion splicing?

1. Gas flame
2. Chrome wire
3. Carbon-dioxide laser
4. Nichrome wire

ASSIGNMENT 5

Textbook Assignment: "Fiber Optics and Lighting Systems," chapter 6, pages 6-9 through 6-50; "Electrical Equipment," chapter 7; "Alarm Systems," chapter 8.

- 5-1. In street lighting, streets are classified into how many categories?
1. Five
 2. Two
 3. Three
 4. Four
- 5-2. Which of the following measurements should NOT be used as a mounting height for a lighting luminaire?
1. 18 feet
 2. 20 feet
 3. 25 feet
 4. 30 feet
- 5-3. A luminaire overhang should not exceed what percentage of its mounting height?
1. 25%
 2. 30%
 3. 35%
 4. 40%
- 5-4. What technical information does a luminaire utilization curve show?
1. The distribution of illumination on the road surface in the vicinity of the luminaire
 2. The amount of light generated within the luminaire
 3. The amount of light that falls on the roadway and adjacent areas
 4. The magnitude and direction of light coming from the luminaire
- 5-5. What technical information does a luminaire isofotocandle curve show?
1. The distribution of illumination on the road surface in the vicinity of the luminaire
 2. The amount of light generated within the luminaire
 3. The amount of light that falls on the roadway and adjacent areas
 4. The magnitude and direction of the light coming from the luminaire
- 5-6. When performing lighting calculations, what factor should you include to compensate for the gradual loss of illumination that is due to accumulated dirt on the luminaire surface?
1. Power factor
 2. Correction factor
 3. Maintenance factor
 4. Illumination factor
- 5-7. Floodlighting luminaries have what total number of National Electrical Manufacturer's Association (NEMA) classifications?
1. Five
 2. Two
 3. Three
 4. Four

5-8. A general-purpose floodlight, with an integral ballast, has what NEMA classification?

1. GP
2. GPB
3. HD
4. HDB

5-9. A NEMA Type 5 floodlight has a horizontal and vertical beam spread of how many degrees?

1. 21
2. 22
3. 45
4. 77

5-10. You are performing lighting calculations and the manufacturer's information is not available for an enclosed floodlight. What maintenance factor should you use in the calculation to compensate for the gradual loss of illumination?

1. 0.76
2. 0.70
3. 0.65
4. 0.55

5-1 1. What types of airfield is/are best suited for helicopter operations?

1. VTOL
2. VSTOL
3. Both 1 and 2
4. SELF

5-12. What type(s) of airfield can accommodate the landing of high-performance aircraft?

1. VSTOL
2. SELF
3. EAF
4. Both 2 and 3

5-1 3. What airfield lighting standards are followed by U.S. military airfields overseas?

1. NAVFAC standards
2. The host nation's aviation standards
3. FAA standards
4. U.S. Air Force standards

5-14. The SELF has how many sets of FOLS and field lighting systems?

1. Five
2. Two
3. Three
4. Four

5-15. In an airfield lighting control circuit, the hot lead is what size of wire?

1. No. 6 AWG
2. No. 7 AWG
3. No. 12 AWG
4. No. 17 AWG

5-16. In an airfield lighting control circuit, what color is the hot lead?

1. Red
2. Blue
3. Black
4. Orange

5-17. Runway edge lights should be installed at what maximum distance from the edge of the runway paving?

1. 5 feet
2. 2 feet
3. 10 feet
4. 15 feet

5-18. When approach lighting circuits are to be installed above ground and the airfield area is not fenced, the circuit should be installed at what minimum height?

1. 8 feet
2. 10 feet
3. 12 feet
4. 22 feet

5-19. The power supply for a runway distance marker light should be the same as the power supply for approach lights.

1. True
2. False

5-20. In an obstruction lighting system, what color are the lights?

1. Orange
2. Yellow
3. Blue
4. Red

5-21. There are how many types of functional beacons?

1. Five
2. Two
3. Three
4. Four

5-22. Which of the following beacons uses a flashing light instead of a rotating light?

1. Airport beacon
2. Identification or code beacon
3. Hazard or obstruction beacon
4. Both 2 and 3

5-23. When you are working very near airfield strobe lights during an airfield operation, what safety precaution should you follow?

1. Wear sunglasses
2. Do not look directly at the light beam
3. Cover the strobe lights to block their light
4. Turn off the power to the strobe lights

5-24. When, if ever, does the control tower have any control over the airfield strobe lighting?

1. Only when the local/remote control unit in the sequence timer cabinet is in the local-on position
2. Only when the local/remote control unit in the sequence timer cabinet is in the remote position
3. Never

5-25. When you are performing an operational test during routine maintenance on an airfield lighting system, you should leave the light on for at least how many hours?

1. 1
2. 2
3. 6
4. 4

5-26. What will happen in an airfield lighting circuit when the output terminals of a constant-current regulator (CCR) in the circuit are accidentally shorted?

1. The circuit will be overloaded
2. There will be a short circuit
3. The CCR will have a no-load condition
4. The CCR will be damaged

- 5-27. What will happen to a CCR in a lighting circuit if its secondary terminals are left open without a load?
1. It will be overloaded
 2. It will be shorted
 3. It will have a no-load condition
 4. There will be no significant effect to the CCR
- 5-28. NEW® requirements for motor-branch circuit and ground fault protection can be found in what part of Article 430?
1. A
 2. B
 3. C
 4. D
- 5-29. Motor-branch circuit protection must protect which of the following circuit components?
1. The motor
 2. The control apparatus
 3. The conductors
 4. All of the above
- 5-30. Which of the following devices can be considered a motor controller?
1. Pilot control device
 2. Circuit breaker
 3. Push button station
 4. Limit switch
- 5-31. The NEC® considers a motor controller to be out of sight when the controller is more than how many feet from the motor?
1. 10
 2. 15
 3. 25
 4. 50
- 5-32. An approved disconnecting means for a motor circuit should have what kind of rating?
1. Ampere
 2. Horsepower
 3. Kilowatt
 4. Voltage
- 5-33. The Code permits a motor disconnecting means to be out of sight if what condition can be met?
1. It can be locked in the ON position
 2. It can be locked in the OPEN position
 3. It can not be locked in the ON position
 4. It can not be locked in the OPEN position
- 5-34. A motor overload protection should be capable of protecting the motor from which of the following circuit condition(s)?
1. Short circuit
 2. Ground fault
 3. Excessive circuit heat
 4. All of the above
- 5-35. What must be done to a regular fuse used as an overload protection for a motor during the motor's starting period?
1. It must be grounded
 2. It must be shunted
 3. It should be outfitted with a time-delaying device
 4. None of the above

- 5-36. Which of the following non-current carrying metal parts of a motor circuit is/are required to be grounded?
1. Cabinets
 2. Boxes
 3. Equipment enclosures
 4. All of the above
- 5-37. Flexible metal conduit is permitted to be used as an equipment grounding conductor provided its length does not exceed how many feet?
1. 6
 2. 10
 3. 15
 4. 20
- 5-38. When flexible metal conduit used as a grounding conductor exceeds its permitted length, you should install what component in the conduit?
1. A neutral wire
 2. An additional hot wire
 3. A bonding jumper wire
 4. A connector listed for grounding
- 5-39. A flexible metal conduit used as an equipment grounding conductor should have circuit conductors within it rated at what maximum amperes?
1. 10
 2. 15
 3. 20
 4. 25
- 5-40. A control circuit is divided into how many classes?
1. Five
 2. Two
 3. Three
 4. Four
- 5-41. In a class 1 control circuit, a number 18 wire should be protected at how many amperes?
1. 7
 2. 10
 3. 16
 4. 18
- 5-42. In a two wire control circuit, what component opens and closes the circuit?
1. Circuit breaker
 2. Start-stop button
 3. Toggle switch
 4. Automatic pilot device
- 5-43. In a three-wire control, what is the function of the maintaining circuit?
1. To maintain the voltage of the circuit
 2. To maintain the current of the circuit
 3. To maintain power to the circuit
 4. To eliminate the need for the operator to press constantly on the start button to keep the controller coil energized
- 5-44. Which of the following is another term for a maintaining circuit?
1. Control circuit
 2. Sealing circuit
 3. Holding circuit
 4. Both 2 and 3

- 5-45. Which of the following components is commonly used to open and close the circuit?
1. Limit switch
 2. Circuit breaker
 3. Push button station
 4. Float switch
- 5-46. A low-voltage control uses a separate low voltage source from which of the following components?
1. Adjustable resistor
 2. Rectifier
 3. Isolation transformer
 4. Small generator
- 5-47. The low-voltage control's supply voltage should come from the same power supply as the motor it is controlling.
1. True
 2. False
- 5-48. Lockout guidance is provided by what instruction?
1. OPNAVINST 5010.23
 2. OPNAVINST 5001.23
 3. OPNAVINST 5100.32
 4. OPNAVINST 5100.23
- 5-49. If a motor does not start when the main contacts of the controller close, which of the following conditions is/are the possible cause(s)?
1. Dirty start button contacts
 2. Open holding coil
 3. Open overload heater coil
 4. Each of the above
- 5-50. If the controller contacts do not close when the start button is pressed, which of the following conditions is a possible cause?
1. Defective load
 2. Grounded circuit
 3. Over voltage
 4. Shorted coil
- 5-51. If the controller contacts open when the start button is pressed, which of the following conditions is a possible cause?
1. A shorted coil
 2. Wrong connection of the push button station
 3. Over voltage
 4. An open overload relay
- 5-52. If a magnetic coil is noisy while in operation, which of the following conditions is a possible cause?
1. Shorted contacts
 2. Shorted coil
 3. Grounded coil
 4. Broken shaded pole
- 5-53. Grease used for lubricating motor bearings should have a melting point not less than how many degrees?
1. 150°F
 2. 212°F
 3. 100°C
 4. 150°C
- 5-54. What is the most common lubrication problem on newer motors?
1. Infrequent greasing
 2. Overgreasing
 3. Undergreasing
 4. Grease melting

5-55. When using an external heating unit to dry moisture from a Class A insulated motor, you should not allow the motor windings to exceed what temperature?

1. 150°C
2. 100°C
3. 150°F
4. 100°F

5-56. What condition indicates an overheated commutator?

1. A polished brown color on the surface of the commutator
2. A bluish color on the surface of the commutator
3. An uneven wear on the commutator
4. A worn out commutator brush

5-57. After you install an electric motor, how long should you initially leave the motor running with a load for observation?

1. 1 hour
2. 1/2 hour
3. 5 minutes
4. 15 minutes

5-58. Which of the following reasons is/are the purpose of a building alarm system?

1. To protect property
2. To detect an intrusion
3. To protect life
4. All of the above

5-59. What is an annunciator?

1. A public address system
2. An audible indicating device
3. A visual indicating device
4. A coding device

5-60. What Article in the NEC® covers the installation of wiring and equipment of fire-protective signaling systems?

1. 607
2. 670
3. 706
4. 760

5-61. In a security wiring circuit, what component allows an authorized person to leave and enter the premises without causing an alarm when the system is on?

1. Tamper switch
2. Key-operated timer
3. Shunt lock
4. Tuner switch

5-62. Which of the following types of installation for fire and security wiring systems is the most difficult to accomplish in an existing building?

1. Surface mounted conduit
2. Wire molding
3. Concealed wiring
4. Exposed wiring

5-63. Which of the following drills is recommended for drilling holes using a flexible shaft?

1. Low-speed
2. High-speed
3. High torque
4. Reversible

- 5-64. In the installation of burglar alarm wiring through a window casement, what size of flexible shaft is recommended?
1. 1/4 inch
 2. 5/16 inch
 3. 3/8 inch
 4. 1/2 inch
- 5-65. While pulling a wire with a flexible shaft attached to a drill, when, if ever, should you reverse the direction of the drill?
1. All the time while pulling the wire
 2. Only when the wire is hard to pull
 3. Only when the bit is passing through a wooden member
 4. Never
- 5-66. Security and fire alarm systems' wiring ranges from what AWG sizes?
1. No. 10 to No. 8
 2. No. 14 to No. 12
 3. No. 20 to No. 16
 4. No. 22 to No. 18
- 5-67. What component is the heart of any security system?
1. Bell
 2. Horn
 3. Control panel
 4. Switchboard
- 5-68. A good rechargeable power supply should be able to operate an alarm system for how many hours without being recharged?
1. 8 hours
 2. 12 hours
 3. 24 hours
 4. 48 hours
- 5-69. A non-rechargeable standby battery power supply for fire alarms is still permitted for use by the NFPA.
1. True
 2. False
- 5-70. Surface magnetic detectors can be mounted by using which of the following materials?
1. Epoxy
 2. Double-sided tape
 3. Screws
 4. All of the above
- 5-71. When installing a detector on windows, the two sections of the detector should be no more than how many inches apart?
1. 1/4 inch
 2. 3/8 inch
 3. 1/2 inch
 4. 5/8 inch
- 5-72. The conductive foil in an alarm system is connected to what conductor?
1. Neutral
 2. Ground
 3. Positive
 4. Negative
- 5-73. What type of motion detector is used to detect sounds caused by an intruder?
1. Infrared detector
 2. Ultrasonic detector
 3. Sound wave detector
 4. Audio detector

5-74. Which of the following detectors is used to protect large areas such as construction sites?

1. Infixed
2. Audio
3. Microwave
4. Vibration

5-75. The proper performance of an ultraviolet-radiation fire detector could be affected by which of the following factors?

1. Sunlight
2. Welding arc
3. Lightning
4. Both 2 and 3

