



**NONRESIDENT
TRAINING
COURSE**



July 2001

Aviation Boatswain's Mate E

NAVEDTRA 14310

DISTRIBUTION STATEMENT A: Approved for public release; distribution is unlimited.

Although the words “he,” “him,” and “his” are used sparingly in this course to enhance communication, they are not intended to be gender driven or to affront or discriminate against anyone.

DISTRIBUTION STATEMENT A: Approved for public release; distribution is unlimited.

PREFACE

By enrolling in this self-study course, you have demonstrated a desire to improve yourself and the Navy. Remember, however, this self-study course is only one part of the total Navy training program. Practical experience, schools, selected reading, and your desire to succeed are also necessary to successfully round out a fully meaningful training program.

COURSE OVERVIEW: When you complete this course you will be familiar with common maintenance tools and their uses, measuring tools and techniques, aircraft recovery equipment, steam catapults, and associated launching equipment. You will also learn about the aircraft launch and recovery equipment maintenance program (ALREMP) and maintenance planning and administration.

THE COURSE: This self-study course is organized into subject matter areas, each containing learning objectives to help you determine what you should learn along with text and illustrations to help you understand the information. The subject matter reflects day-to-day requirements and experiences of personnel in the rating or skill area. It also reflects guidance provided by Enlisted Community Managers (ECMs) and other senior personnel, technical references, instructions, etc., and either the occupational or naval standards, which are listed in the *Manual of Navy Enlisted Manpower Personnel Classifications and Occupational Standards*, NAVPERS 18068.

THE QUESTIONS: The questions that appear in this course are designed to help you understand the material in the text.

VALUE: In completing this course, you will improve your military and professional knowledge. Importantly, it can also help you study for the Navy-wide advancement in rate examination. If you are studying and discover a reference in the text to another publication for further information, look it up.

*2001 Edition Prepared by
ABECS(AW) Johnny Eggleston*

Published by
NAVAL EDUCATION AND TRAINING
PROFESSIONAL DEVELOPMENT
AND TECHNOLOGY CENTER

NAVSUP Logistics Tracking Number
0504-LP-026-4030

Sailor's Creed

“I am a United States Sailor.

I will support and defend the Constitution of the United States of America and I will obey the orders of those appointed over me.

I represent the fighting spirit of the Navy and those who have gone before me to defend freedom and democracy around the world.

I proudly serve my country's Navy combat team with honor, courage and commitment.

I am committed to excellence and the fair treatment of all.”

TABLE OF CONTENTS

CHAPTER	PAGE
1. Common Maintenance Tools and their Uses.....	1-1
2. Measuring Tools and Techniques.....	2-1
3. Mk 7 Aircraft Recovery Equipment and Emergency Recovery Equipment	3-1
4. Steam Catapults	4-1
5. Associated Launching Equipment	5-1
6. The Aircraft Launch and Recovery Equipment Maintenance Program.....	6-1
7. Maintenance Planning and Administration	7-1
APPENDIX	
I. Glossary	AI-1
II. References.....	AII-1
III. Answers to Review Questions	AIII-1
INDEX	INDEX-1

INSTRUCTIONS FOR TAKING THE COURSE

ASSIGNMENTS

The text pages that you are to study are listed at the beginning of each assignment. Study these pages carefully before attempting to answer the questions. Pay close attention to tables and illustrations and read the learning objectives. The learning objectives state what you should be able to do after studying the material. Answering the questions correctly helps you accomplish the objectives.

SELECTING YOUR ANSWERS

Read each question carefully, then select the BEST answer. You may refer freely to the text. The answers must be the result of your own work and decisions. You are prohibited from referring to or copying the answers of others and from giving answers to anyone else taking the course.

SUBMITTING YOUR ASSIGNMENTS

To have your assignments graded, you must be enrolled in the course with the Nonresident Training Course Administration Branch at the Naval Education and Training Professional Development and Technology Center (NETPDTC). Following enrollment, there are two ways of having your assignments graded: (1) use the Internet to submit your assignments as you complete them, or (2) send all the assignments at one time by mail to NETPDTC.

Grading on the Internet: Advantages to Internet grading are:

- you may submit your answers as soon as you complete an assignment, and
- you get your results faster; usually by the next working day (approximately 24 hours).

In addition to receiving grade results for each assignment, you will receive course completion confirmation once you have completed all the

assignments. To submit your assignment answers via the Internet, go to:

<http://courses.cnet.navy.mil>

Grading by Mail: When you submit answer sheets by mail, send all of your assignments at one time. Do NOT submit individual answer sheets for grading. Mail all of your assignments in an envelope, which you either provide yourself or obtain from your nearest Educational Services Officer (ESO). Submit answer sheets to:

COMMANDING OFFICER
NETPDTC N331
6490 SAUFLEY FIELD ROAD
PENSACOLA FL 32559-5000

Answer Sheets: All courses include one "scannable" answer sheet for each assignment. These answer sheets are preprinted with your SSN, name, assignment number, and course number. Explanations for completing the answer sheets are on the answer sheet.

Do not use answer sheet reproductions: Use only the original answer sheets that we provide—reproductions will not work with our scanning equipment and cannot be processed.

Follow the instructions for marking your answers on the answer sheet. Be sure that blocks 1, 2, and 3 are filled in correctly. This information is necessary for your course to be properly processed and for you to receive credit for your work.

COMPLETION TIME

Courses must be completed within 12 months from the date of enrollment. This includes time required to resubmit failed assignments.

PASS/FAIL ASSIGNMENT PROCEDURES

If your overall course score is 3.2 or higher, you will pass the course and will not be required to resubmit assignments. Once your assignments have been graded you will receive course completion confirmation.

If you receive less than a 3.2 on any assignment and your overall course score is below 3.2, you will be given the opportunity to resubmit failed assignments. **You may resubmit failed assignments only once.** Internet students will receive notification when they have failed an assignment—they may then resubmit failed assignments on the web site. Internet students may view and print results for failed assignments from the web site. Students who submit by mail will receive a failing result letter and a new answer sheet for resubmission of each failed assignment.

COMPLETION CONFIRMATION

After successfully completing this course, you will receive a letter of completion.

ERRATA

Errata are used to correct minor errors or delete obsolete information in a course. Errata may also be used to provide instructions to the student. If a course has an errata, it will be included as the first page(s) after the front cover. Errata for all courses can be accessed and viewed/downloaded at:

<http://www.advancement.cnet.navy.mil>

STUDENT FEEDBACK QUESTIONS

We value your suggestions, questions, and criticisms on our courses. If you would like to communicate with us regarding this course, we encourage you, if possible, to use e-mail. If you write or fax, please use a copy of the Student Comment form that follows this page.

For subject matter questions:

E-mail: n315.products@cnet.navy.mil
Phone: Comm: (850) 452-1001, ext. 1777
DSN: 922-1001, ext. 1777
FAX: (850) 452-1370
(Do not fax answer sheets.)
Address: COMMANDING OFFICER
NETPDTC N315
6490 SAUFLEY FIELD ROAD
PENSACOLA FL 32509-5237

For enrollment, shipping, grading, or completion letter questions

E-mail: fleetservices@cnet.navy.mil
Phone: Toll Free: 877-264-8583
Comm: (850) 452-1511/1181/1859
DSN: 922-1511/1181/1859
FAX: (850) 452-1370
(Do not fax answer sheets.)
Address: COMMANDING OFFICER
NETPDTC (CODE N331)
6490 SAUFLEY FIELD ROAD
PENSACOLA FL 32559-5000

NAVAL RESERVE RETIREMENT CREDIT

If you are a member of the Naval Reserve, you will receive retirement points if you are authorized to receive them under current directives governing retirement of Naval Reserve personnel. For Naval Reserve retirement, this course is evaluated at 8 points. (Refer to *Administrative Procedures for Naval Reservists on Inactive Duty*, BUPERSINST 1001.39, for more information about retirement points.)

(THIS PAGE IS INTENTIONALLY LEFT BLANK.)

Student Comments

Course Title: Aviation Boatswain's Mate E

NAVEDTRA: 14310 Date: _____

We need some information about you:

Rate/Rank and Name: _____ SSN: _____ Command/Unit _____

Street Address: _____ City: _____ State/FPO: _____ Zip _____

Your comments, suggestions, etc.:

Privacy Act Statement: Under authority of Title 5, USC 301, information regarding your military status is requested in processing your comments and in preparing a reply. This information will not be divulged without written authorization to anyone other than those within DOD for official use in determining performance.

NETPDTC 1550/41 (Rev 4-00)

CHAPTER 1

COMMON MAINTENANCE TOOLS AND THEIR USES

Tools are designed to make a job easier and enable you to work more efficiently. If they are not properly used and cared for, their advantages are lost to you.

Regardless of the type of work to be done, you must have, choose, and use the correct tools in order to do your work quickly, accurately, and safely. Without the proper tools and the knowledge of how to use them, you waste time, reduce your efficiency, and may even injure yourself.

This chapter explains the specific purposes, correct use, and proper care of the more common tools you will encounter as an ABE. Also discussed briefly are other aids to maintenance, such as blueprints and schematics.

TOOL WORK HABITS

LEARNING OBJECTIVES: Describe the Tool Control Program. List several good tool work habits.

"A place for everything and everything in its place" is just good common sense. You can't do an efficient repair job if you have to stop and look around for each tool you need. The following rules will make your job easier and safer.

KEEP EACH TOOL IN ITS PROPER STOWAGE PLACE. All V-2 divisions have incorporated a Tool Control Program as directed by the Aircraft Launch and Recovery Equipment Maintenance Program (ALREMP).

The Tool Control Program is based on the concept of a family of specialized toolboxes and pouches configured for instant inventory before and after each maintenance action. The content and configuration of each container is tailored to the task, work center, and equipment maintained. Work center containers are assigned to and maintained within a work center. Other boxes and specialized tools are checked out from the tool control center (tool room).

KEEP YOUR TOOLS IN GOOD CONDITION. Protect them from rust, nicks, burrs, and breakage.

KEEP YOUR TOOL ALLOWANCE COMPLETE. When you are issued a toolbox, each tool should be placed in it when not in use. When the

toolbox is not actually at the work site, it should be locked and stored in a designated area.

NOTE

An inventory list is kept in every toolbox to be checked before and after each job or maintenance action, to ensure that all tools are available to do your work, and to ensure that they are accounted for after you have completed your work.

USE EACH TOOL ONLY FOR THE JOB IT WAS DESIGNED TO DO. Each particular type of tool has a specific purpose. If you use the wrong tool when performing maintenance or repairs, you may cause damage to the equipment you're working on or damage the tool itself. Remember, improper use of tools results in improper maintenance. Improper maintenance results in damage to equipment and possible injury or death to you or others.

SAFE MAINTENANCE PRACTICES. Always avoid placing tools on or above machinery or an electrical apparatus. Never leave tools unattended where machinery or aircraft engines are running.

NEVER USE DAMAGED TOOLS. A battered screwdriver may slip and spoil the screw slot, damage other parts, or cause painful injury. A gauge strained out of shape will result in inaccurate measurements.

Remember, the efficiency of craftsmen and the tools they use are determined to a great extent by the way they keep their tools. Likewise, they are frequently judged by the manner in which they handle and care for them. Anyone watching skilled craftsmen at work notices the care and precision with which they use the tools of their trade.

The care of hand tools should follow the same pattern as for personal articles; that is, always keep hand tools clean and free from dirt, grease, and foreign matter. After use, return tools promptly to their proper place in the toolbox. Improve your own efficiency by organizing your tools so that those used most frequently can be reached easily without digging through the entire contents of the box. Avoid accumulating unnecessary junk.

REVIEW QUESTIONS

- Q1. *Describe the Tool Control Program.*
- Q2. *List several good tool work habits.*
- Q3. *What are inspection mirrors used for?*

CARE OF HAND TOOLS

LEARNING OBJECTIVES: List several principles that apply to the care of hand tools.

Tools are expensive; tools are vital equipment. When the need for their use arises, common sense plus a little preventive maintenance prolongs their usefulness. The following precautions for the care of tools should be observed:

- Clean tools after each use. Oily, dirty, and greasy tools are slippery and dangerous to use.
- NEVER hammer with a wrench.
- NEVER leave tools scattered about. When they are not in use, stow them neatly on racks or in toolboxes.
- Apply a light film of oil after cleaning to prevent rust on tools.
- INVENTORY tools after use to prevent loss.

REVIEW QUESTION

- Q4. *List several principles that apply to the care of hand tools.*

PERSONAL SAFETY EQUIPMENT

LEARNING OBJECTIVES: Identify the types of personal safety equipment.

To protect you from danger, protective equipment such as safety shoes, goggles, hard hats, and gloves are issued. The use of this equipment is mandatory on certain jobs. Their use is a **MUST**, and there is no question about that. Be sure to **USE THEM** on any job **WHERE** they are **REQUIRED**. They can protect you from a lot of harm.

SAFETY SHOES

Some safety shoes are designed to limit damage to your toes from falling objects. A steel plate is placed in the toe area of such shoes so that your toes are not crushed if an object impacts there.

Other safety shoes are designed for use where danger from sparking could cause an explosion. Such danger is minimized by elimination of all metallic nails and eyelets and by the use of soles that do not cause static electricity.

GOGGLES

Proper eye protection is of the utmost importance for all personnel. Eye protection is necessary because of hazards posed by infrared and ultraviolet radiation, or by flying objects such as sparks, globules of molten metal, or chipped concrete and wood. These hazards are ever-present during welding, cutting, soldering, chipping, grinding, and a variety of other operations. It is **IMPERATIVE** for you to use eye protection devices, such as helmets, face shields, and goggles (fig. 1-1), during eye-hazard operations.

Appropriate use of goggles will limit eye hazards. Some goggles have plastic lenses that resist shattering upon impact. Others are designed to limit harmful infrared and ultraviolet radiation from arcs or flames by use of appropriate filter lenses.

Remember, eye damage can be excruciatingly painful. **PROTECT YOUR EYES.**

GLOVES

Use gloves whenever you are required to handle rough, scaly, or splintery objects. Special flameproof gloves are designed for gas and electric-arc welding to limit danger and damage from sparks and other hot flying objects (fig. 1-2). Personnel in the electrical fields are usually required to wear insulating rubber gloves.

Be sure to follow all regulations prescribed for the use of gloves. Gloves must not be worn around rotating machinery unless sharp or rough material is being handled. If such is the case, **EXTREME CARE SHOULD BE EXERCISED** to prevent the gloves from being caught in the machinery.

SAFETY BELTS AND STRAPS

The safety strap and body belt shown in figure 1-3 are what might be called your extra hands when you work aloft. The body belt, strapped around your waist, contains various pockets for small tools. The safety strap is a leather or neoprene-impregnated nylon belt with a tongue-type buckle at each end. While you are climbing you will have the safety strap hanging by both ends from the left ring (called a D-ring because of its

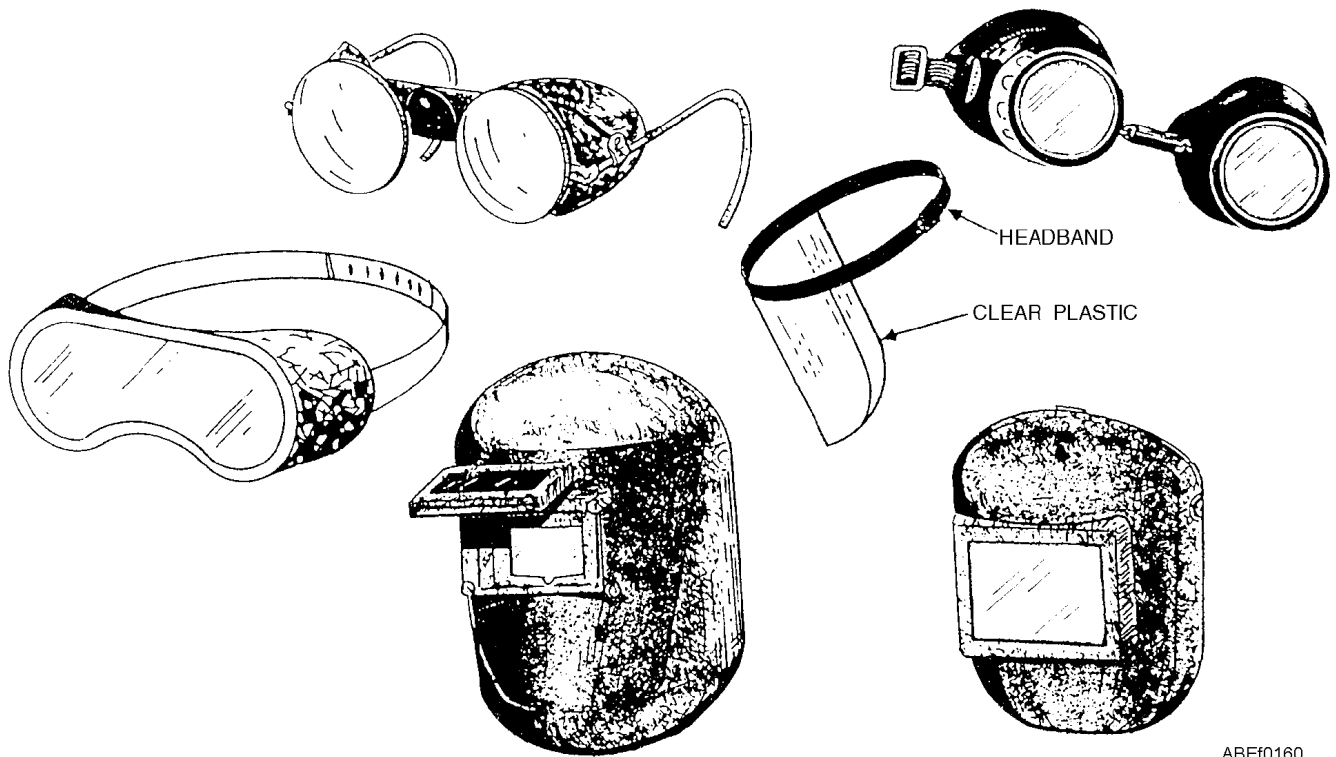

ABEF0160

Figure 1-1.—Eye-protection devices.

shape) on the body belt. When you are at working position, you unstrap one end of the safety strap, pass it around the supporting structure so there is no danger of its slipping (at least 18 inches from the top of the part on which it is fastened), and hook it to the right D-ring on the body belt.

The safety strap must be placed around a part of the structure that is of sufficient strength to sustain an ABs weight and his or her equipment, and must rest flat against the surface without twists or turns. It must not

be placed around any part of a structure that is being removed.

Before placing your weight on the strap, determine VISUALLY that the snap and D-ring are properly engaged. Do not rely on the click of the snap-tongue as an indication that the fastening is secure.

The body belt and safety strap require inspection before use. Look for loose or broken rivets; cracks, cuts, nicks, tears or wear in leather; broken or otherwise defective buckles, such as enlarged tongue-holes, defects in safety-belt snap hooks and body belt D-rings. If you discover any of these or other defects, turn in your equipment and replace it.

Perform maintenance periodically according to applicable procedures. Remember that leather and nylon belts are treated in different manners.

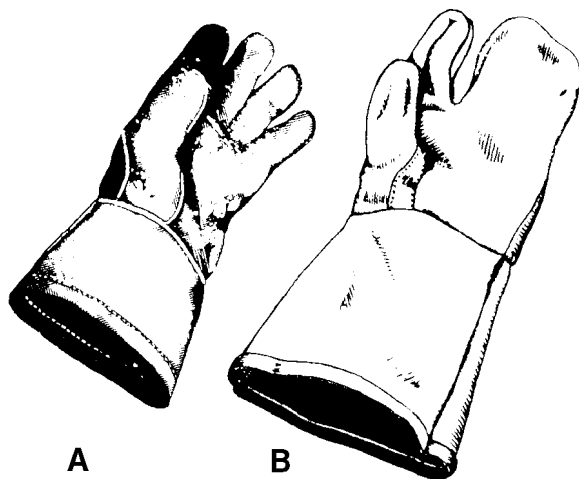

ABEF0161

Figure 1-2.—Gas and electric-arc welding gloves.

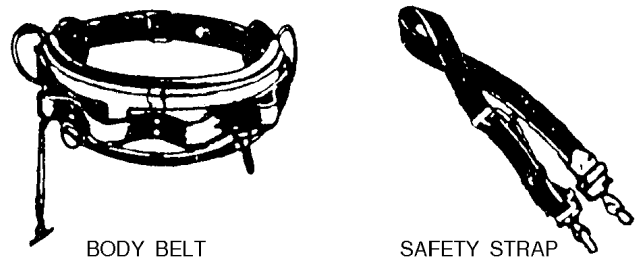

BODY BELT

SAFETY STRAP

ABEF0162

Figure 1-3.—Safety equipment.

REVIEW QUESTION

- Q5. *Identify the different types of personal safety equipment.*

MAINTENANCE AIDS

LEARNING OBJECTIVES: Read and interpret blueprints, drawings, diagrams, and other maintenance aids.

As an ABE you will be required to read blueprints and drawings during the performance of many maintenance actions required to maintain the operational readiness of the catapults and the arresting gear engines. As you advance in rating you may also be required to make sketches and drawings, which will assist you in the training of less-experienced maintenance personnel by making it possible for them to visualize the system or object you are explaining.

BLUEPRINTS AND DRAWINGS

Blueprints are exact copies of mechanical or other types of drawings and employ a language of their own. It is a form of sign language or shorthand that uses lines, graphic symbols, dimensions, and notations to accurately describe the form size, kind of material, finish, and construction of an object. It can be said that blueprint reading is largely a matter of translating these lines and symbols into terms of procedure, materials, and other details needed to repair, maintain, or fabricate the object described on the print.

Usually you can look at a blueprint and recognize the object if you are familiar with the actual part. But when you are required to make or check on a certain part, the applicable blueprint must be referred to in order to get dimensions and other pertinent information. The important thing is to know what the different symbols stand for and where to look for the important information on a blueprint. Some of the important facts listed on all blueprints are discussed in the following paragraphs.

Title Block

The title block is located in the lower right corner of all blueprints and drawings prepared according to military standards. The block contains the drawing number, the name of the part or assembly that the blueprint represents, and all information required to identify the part or assembly.

The title block also includes the name and address of the Government agency or organization preparing the drawing, the scale, drafting record, authentication, and the date (fig. 1-4).

A space within the title block with a diagonal or slant line drawn across it indicates that the information usually placed in it is not required or is given elsewhere on the drawing.

Revision Block

The revision block (not shown) is usually located in the upper right corner of the blueprint and is used for the recording of changes (revisions) to the print. All revisions are noted in this block and are dated and identified by a letter and a brief description of the revision. A revised drawing is shown by the addition of a letter to the original number in the title block, as shown in figure 1-4, view A. If the print shown in figure 1-4, view A, was again revised, the letter in the revision block of the title block would be replaced by the letter *B*.

Drawing Number

All blueprints are identified by a drawing number (NAVSHIP Systems Command No. in view A of fig. 1-4, and FEC Drawing No. in view B), which appears in a block in the lower right corner of the title block. It may be shown in other places also; for example, near the top border line in an upper corner, or on the reverse side at both ends so that it will be visible when a drawing is rolled up. If a blueprint has more than one sheet, this information is included in the block indicating the sheet number and the number of sheets in the series. For example, note that in the title blocks shown in figure 1-4 the blueprint is sheet 1 of 1.

Reference Numbers

Reference numbers that appear in the title block refer to numbers of other blueprints. When more than one detail is shown on a drawing, a dash and a number are frequently used. For example, if two parts are shown in one detail drawing, both prints would have the same drawing number, plus a dash and an individual number, such as 8117041-1 and 8117041-2.

In addition to appearing in the title block, the dash and number may appear on the face of the drawings, near the parts they identify. Some commercial prints show the drawing and dash number, and point with a leader line to the part; others use a circle, 3/8 inch in

NN DWG NO. 0101 46		NEWPORT NEWS SHIPBUILDING & DRY DOCK CO. NEWPORT NEWS, VIRGINIA FSCM NO. 43689 HULL DESIGN DIV STRUCTURAL DEPT					
DRAWN <i>J.A. Doe</i> CHECKED <i>J.R. Frost</i> SUPVR <i>W.J. Doe</i> DATE <i>6/11/95</i>		TITLE AIRCRAFT CARRIER CVAN 68 DOUBLE BOTTOM AFT OF FRAME 180 COMPARTMENT & ACCESS.					
EXAMINED <i>John Boat</i> DATE COMPLETED <i>5/17/95</i>		APPROVED <i>Ch. B. Seaman</i> DATE JUL 17 1995 <small>FOR SUPERVISOR OF SHIPBUILDING USN</small>					
AUTHORIZED		TYPE OF DWG WORKING DRAWING		SIZE H	CODE IDENT NO 80064	NAVSHIP SYSTEM COMMAND NO. 800 2647537	REV. A
		SCALE $\frac{1}{8} = 1\text{FT.}$		SHEET 1 OF 1			

A

DES. <i>Mary (M) Christmas</i> DRWN. <i>Mary (M) Christmas</i> CHK. <i>Ch. B. Seaman</i> SUPV. <i>Paul T. Brute</i> IN CHARGE <i>Yany C. Pistol</i>		DEPARTMENT OF THE NAVY NAVAL FACILITIES ENGINEERING COMMAND U. S. NAVAL STATION, WASHINGTON, D.C. <i>INSTALLATION OF NEW LIGHTING BLDG. 220-3 & 4 WASHINGTON NAVY YARD</i>			
SATISFACTORY TO <i>Flas A. Brute</i>		CODE IDENT. NO. 80091	SIZE F	FEC DRAWING NO. 1167420	
APPROVED <i>John Boat</i> DATE <i>5/17/95</i> OFFICER IN CHARGE		SCALE $\frac{1}{8} = 1'$		SPEC. 82805/91 NBy 82805	SHEET 1 OF 1
APPROVED <i>J.R. Frost</i> DATE <i>5/12/95</i> PUBLIC WORKS OFFICER					

B

ABE0172

Figure 1-4.—Blueprint title blocks. (A) Naval Ship's Systems Command; (B) Naval Facilities Engineering Command.

diameter, around the dash number, and carry a leader line to the part.

A dash and number are used to identify modified or improved parts, and also to identify right-hand and left-hand parts. Many aircraft parts on the left-hand side of an aircraft are exactly like the corresponding parts on the right-hand side but in reverse. The left-hand parts are usually shown in the drawing.

Above the title block on some prints you may see a notation such as "159674 LH shown; 159674-1 RH opposite." Both parts carry the same number. But the part called for is distinguished by a dash and number. (LH means left-hand, and RH means right-hand.) Some companies use odd numbers for right-hand parts and even numbers for left-hand parts.

Drawing Lines

The lines used in working drawings are more than a means of showing a picture of an object for the purpose of building or repairing. The way a line is drawn has a definite meaning.







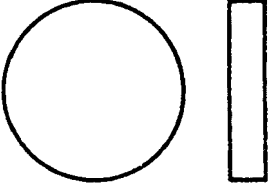

Thick lines are used for the visible outline of the object being drawn. Medium lines are used for the dotted lines representing hidden features and for cutting-plane, short-break, adjacent-part, and alternate-position lines. Center lines, dimension lines, long-break lines, ditto lines, extension lines, and section lines are represented by thin lines.

To understand blueprint reading, you must know the different types of lines used in general drawing practice and the information conveyed by each. Some of the lines of major importance are illustrated in

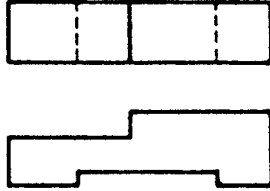
figures 1-5-A and 1-5-B. The correct uses are illustrated in figure 1-6.

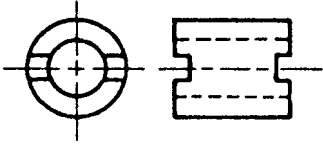
Blueprints make it possible to understand, in a comparatively small space, what is to be made or repaired. Of the many types of blueprints you will use aboard ship, the simplest one is the plan view. This type

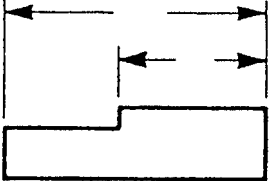

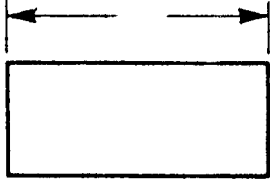



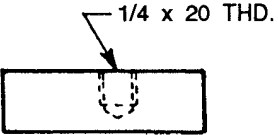

of blueprint shows the position, location, and use of the various parts of the ship; for example, to find the battlestations sickbay, barbershop, or other parts of the ship. In addition to plan views, other blueprints, called assembly prints, unit or subassembly prints, and detail prints, show various kinds of machinery and mechanical equipment.

LINE STANDARDS			
NAME	CONVENTION	DESCRIPTION AND APPLICATION	EXAMPLE
VISIBLE LINES		HEAVY UNBROKEN LINES USED TO INDICATE VISIBLE EDGES OF AN OBJECT	
HIDDEN LINES		MEDIUM LINES WITH SHORT EVENLY SPACED DASHES USED TO INDICATE CONCEALED EDGES	
CENTER-LINES		THIN LINES MADE UP OF LONG AND SHORT DASHES ALTERNATELY SPACED AND CONSISTENT IN LENGTH USED TO INDICATE SYMMETRY ABOUT AN AXIS AND LOCATION OF CENTERS	
DIMENSION LINES		THIN LINES TERMINATED WITH ARROWHEADS AT EACH END USED TO INDICATE DISTANCE MEASURED	
EXTENSION LINES		THIN UNBROKEN LINES USED TO INDICATE EXTENT OF DIMENSIONS	

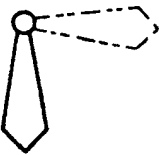
ABEF0173

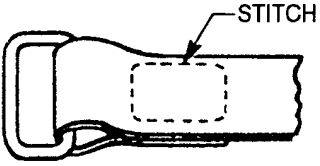
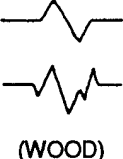
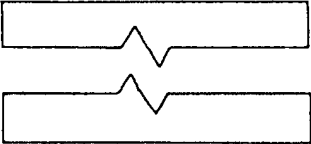
(A)

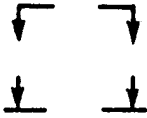
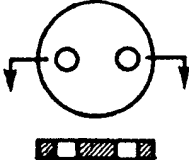
Figure 1-5-A.—Standard lines.

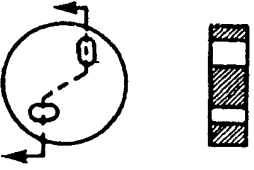
NAME	CONVENTION	DESCRIPTION AND APPLICATION	EXAMPLE
LEADER		THIN LINE TERMINATED WITH ARROW-HEAD OR DOT AT ONE END USED TO INDICATE A PART, DIMENSION OR OTHER REFERENCE	
PHANTOM OR DATUM LINE		MEDIUM SERIES OF ONE LONG DASH AND TWO SHORT DASHES EVENLY SPACED ENDING WITH LONG DASH USED TO INDICATE ALTERNATE POSITION OF PARTS, REPEATED DETAIL OR TO INDICATE A DATUM PLANE	
STITCH LINE		MEDIUM LINE OF SHORT DASHES EVENLY SPACED AND LABELED USED TO INDICATE STITCHING OR SEWING	
BREAK (LONG)		THIN SOLID RULED LINES WITH FREEHAND ZIG-ZAGS USED TO REDUCE SIZE OF DRAWING REQUIRED TO DELINEATE OBJECT AND REDUCE DETAIL	
BREAK (SHORT)		THICK SOLID FREE HAND LINES USED TO INDICATE A SHORT BREAK	
CUTTING OR VIEWING PLANE VIEWING PLANE OPTIONAL		THICK SOLID LINES WITH ARROWHEAD TO INDICATE DIRECTION IN WHICH SECTION OR PLANE IS VIEWED OR TAKEN	
CUTTING PLANE FOR COMPLEX OR OFFSET VIEWS		THICK SHORT DASHES USED TO SHOW OFFSET WITH ARROWHEADS TO SHOW DIRECTION VIEWED	

ABEF0174

(B)

Figure 1-5-B.—Standard lines—continued.

Assembly prints show the various parts of the mechanism, how the parts fit together, and their relation to each other. Subassembly prints show the location, shape, size, and relationships of the parts of the subassembly or unit. Detail prints show a single part

with its dimensions and all the information needed to make a new part as a replacement. Assembly and subassembly prints may be used to learn operation and maintenance of machines, systems, and equipment.

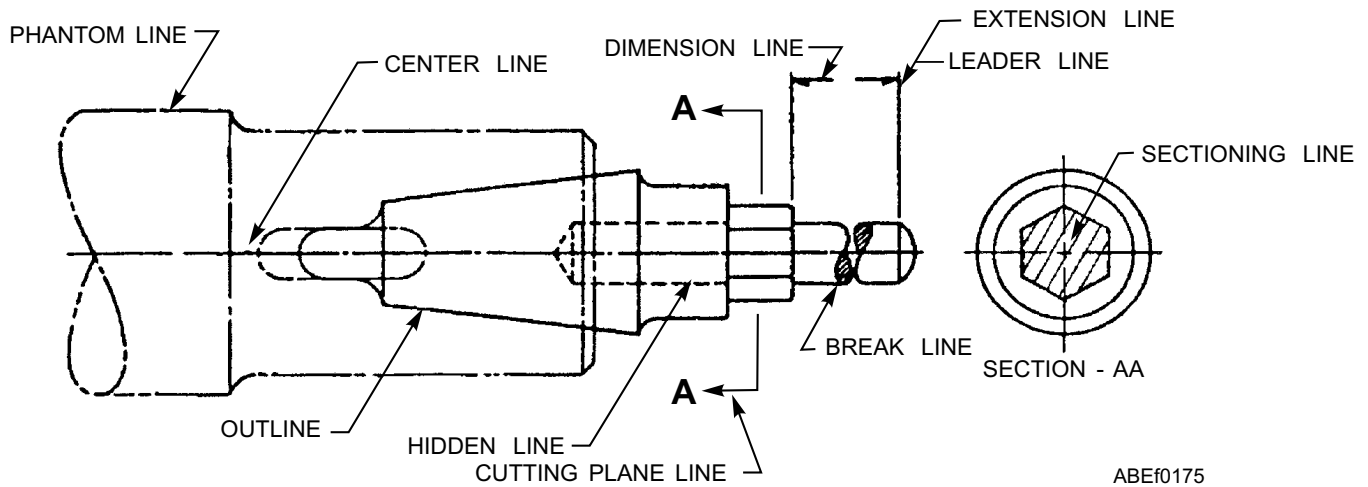

Figure 1-6.—Use of standard lines.

MICROFILM/APERTURE CARDS

Many prints and drawings are procured in the form of 16- and 35-mm microfilm. Microfilm prints and drawings are available mounted on aperture (viewer) cards, as well as in roll form. A reader or some type of projector is required to enlarge the microfilm for reading. Activities are provided with a microfilm reader-printer, which as its name implies, enlarges the microfilm for reading and also has the capability of printing a working copy in a matter of a few seconds.

Microfilm greatly reduces the size of otherwise bulky files, which is very important aboard ship.

SCHEMATIC DIAGRAMS

Schematic diagrams show by means of single lines and symbols how the parts of a system are connected for the operation of the system.

Piping

Piping diagrams are normally used to trace piping systems and their functions without actually describing the shape, size, or location of the components or parts. Each component is represented by a symbol; and once these symbols are learned, the piping schematic diagram is easy to read.

Figure 1-7 is a good example of a piping diagram. As may be seen from this example, diagrams do not indicate the location of individual components within the station, but do locate the components with respect to each other within the system.

Electrical

Schematic diagrams are also used to depict electrical systems. They are basically the same as the

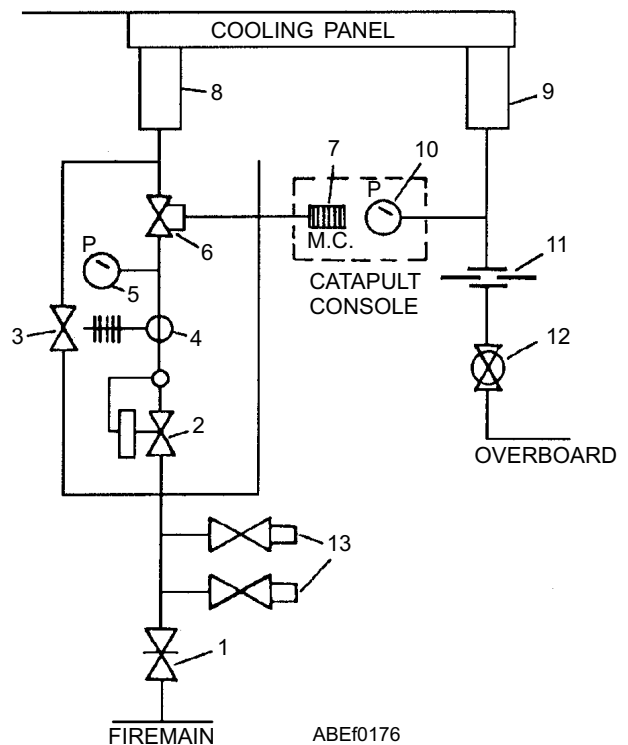

- | | | |
|----------------------|---------------------|--------------------|
| 1. Cutout valve. | 6. Hytrol valve. | 11. Orifice. |
| 2. Reducing valve | 7. Pilot valve. | 12. Scupper valve. |
| 3. Throttling valve. | 8. Inlet lines. | 13. Hose valves. |
| 4. Relief valve. | 9. Discharge lines. | |
| 5. Test gauge. | 10. Pressure gage. | |

Figure 1-7.—Typical piping schematic for saltwater cooling.

piping diagrams except they use electrical symbols instead of piping symbols. Figure 1-8 is an example of an electrical system schematic.

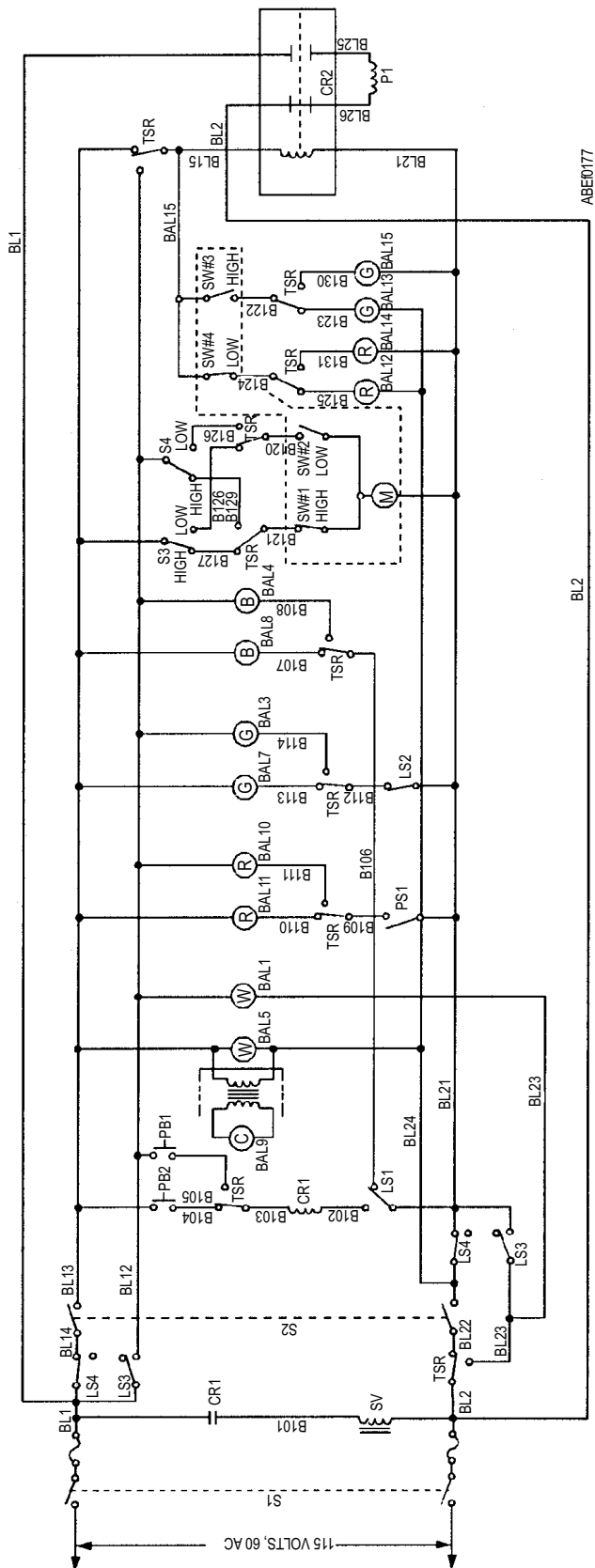

Figure 1-8.—Electrical system schematic.

Schematic diagrams are especially helpful when you are learning a hydraulic system or pinpointing a malfunction in an electrical system. For more information on diagrams, drawings, and blueprints, and their interpretation, study *Blueprint Reading and Sketching*, NAVEDTRA 12014.

REVIEW QUESTION

Q6. Where is the title block located on all blueprints and drawings prepared to military standards?

METAL-CUTTING TOOLS

LEARNING OBJECTIVES: Identify the different types of metal-cutting tools. Describe the uses of different types of cutting tools.

Many types of metal-cutting tools are used by skilled mechanics of all ratings. As you become better acquainted with the ABE rating, you will probably discover many tools that you use for cutting metal that are not described in this text. In this text, only the basic hand metal-cutting tools will be considered.

SNIPS AND SHEARS

Snips and shears are used for cutting sheet metal and steel of various thickness and shapes. Normally, the heavier or thicker materials are cut by shears.

One of the handiest tools for cutting light (up to 1/16-inch thick) sheet metal is the hand snip (tip snips). The STRAIGHT HAND SNIPS, shown in figure 1-9,

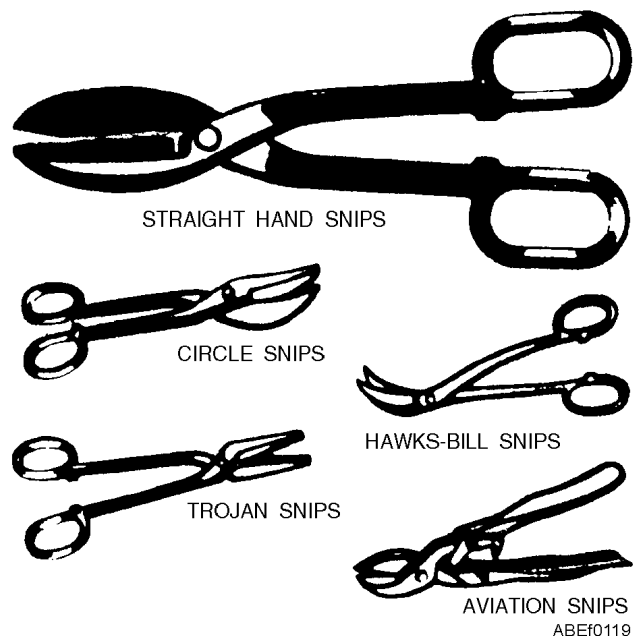

Figure 1-9.—Metal snips.

have blades that are straight and cutting edges that are sharpened to an 85-degree angle. Snips like this can be obtained in different sizes, ranging from the small, 6-inch, to the large, 14-inch, snip. Tin snips will also work on slightly heavier gauges of soft metals, such as aluminum alloys.

Snips will not remove any metal when a cut is made. There is danger, though, of causing minute metal fractures along the edges of the metal during the shearing process. For this reason, it is better to cut just outside the layout line. This procedure will allow you to dress the cutting edge while keeping the material within required dimensions.

Cutting extremely heavy gauge metal always presents the possibility of springing the blades. Once the blades are sprung, hand snips are useless. When cutting heavy material, use the rear portion of the blades. This procedure not only avoids the possibility of springing the blades but also gives you greater cutting leverage.

Many snips have small serrations (notches) on the cutting edges of the blades. These serrations tend to prevent the snips from slipping backwards when a cut is being made. Although this feature does make the actual cutting easier, it mars the edges of the metal slightly. You can remove these small cutting marks if you allow proper clearance for dressing the metal to size. There are many other types of hand snips used for special jobs, but the snips discussed here can be used for almost any common type of work.

Cutting Sheet Metal with Snips

It is hard to cut circles or small arcs with straight snips. There are snips especially designed for circular cutting. They are called **CIRCLE SNIPS**, **HAWKS-BILL SNIPS**, **TROJAN SNIPS**, and **AVIATION SNIPS** (fig. 1-9).

To cut large holes in the lighter gauges of sheet metal, start the cut by punching or otherwise making a hole in the center of the area to be cut out. With an aviation snips, or some other narrow-bladed snips, make a spiral cut from the starting hole out toward the scribed circle, as shown in figure 1-10, and continue cutting until the scrap falls away.

To cut a disk in the lighter gauges of sheet metal, use a combination snips or a straight-blade snips, as shown in figure 1-11. First, cut away any surplus material outside the scribed circle, leaving only a narrow piece to be removed by the final cut. Make the

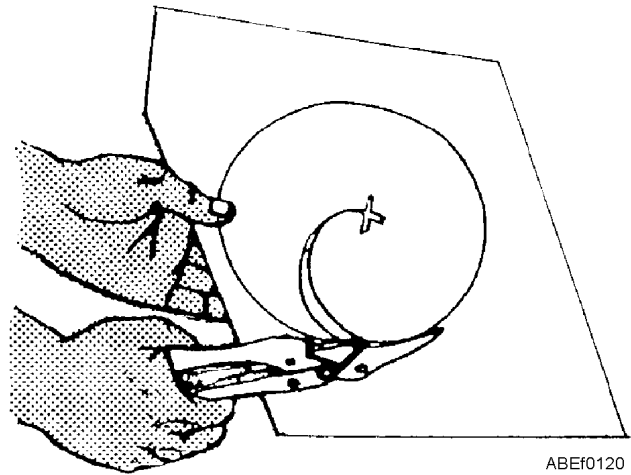

Figure 1-10.—Cutting an inside hole with snips.

final cut just outside the layout line. This will permit you to see the scribed line while you are cutting and will cause the scrap to curl up below the blade of the snips, where it will be out of the way while the complete cut is being made.

To make straight cuts, place the sheet metal on a bench with the marked guideline over the edge of the bench and hold the sheet down with one hand. With the other hand, hold the snips so that the flat sides of the blades are at right angles to the surface of the work. If the blades are not at right angles to the surface of the work, the edges of the cut will be slightly bent and burred. The bench edge will also act as a guide when you are cutting with the snips. The snips will force the scrap metal down so that it does not interfere with cutting. Any of the hand snips may be used for straight cuts. When notches are too narrow to be cut out with a pair of snips, make the side cuts with the snips and cut the base of the notch with a cold chisel.

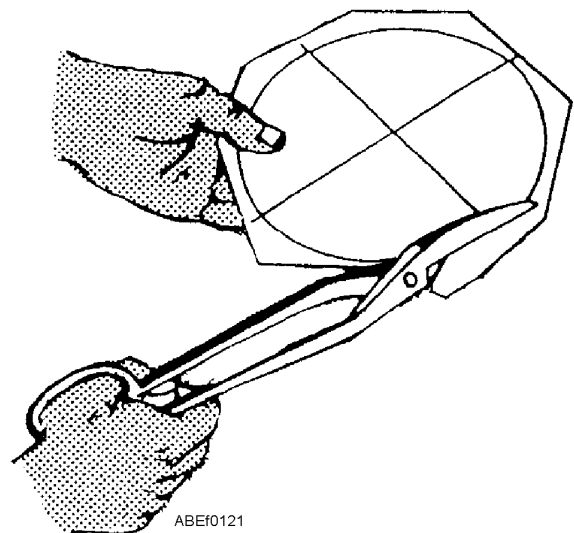

Figure 1-11.—Cutting a disk out of sheet metal.

Safety and Care

Learn to use snips properly. They should always be oiled and adjusted to permit ease of cutting and to produce a surface that is free from burrs. If the blades bind or if they are too far apart, the snips should be adjusted. Remember the following safety tips:

- Never use snips as screwdrivers, hammers, or pry bars. They break easily.
- Do not attempt to cut heavier materials than the snips are designed for. Never use tin snips to cut hardened steel wire or other similar objects. Such use will dent or nick the cutting edges of the blades.
- Never toss snips in a toolbox where the cutting edges can come into contact with other tools. This dulls the cutting edges and may even break the blades.
- When snips are not in use, hang them on hooks or lay them on an uncrowded shelf or bench.

HACKSAWS

Hacksaws are used to cut metal that is too heavy for snips or bolt cutters. Thus, metal bar stock can be cut readily with hacksaws.

There are two parts to a hacksaw: the frame and the blade. Common hacksaws have either an adjustable or a solid frame (fig. 1-12). Most hacksaws found in the Navy are of the adjustable-frame type. Adjustable frames can be made to hold blades from 8 to 16 inches long, while those with solid frames take only the length blade for which they are made. This length is the

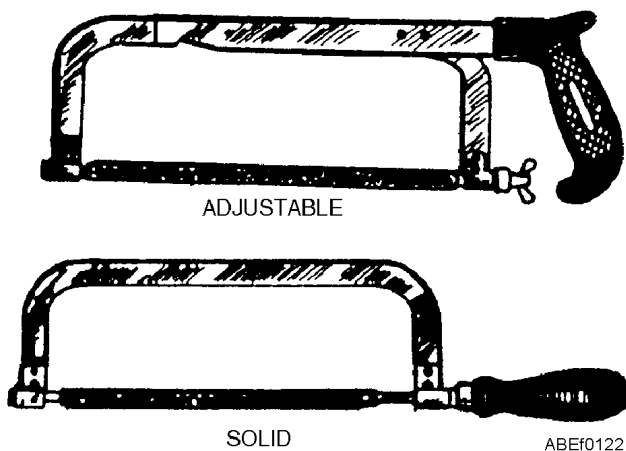

Figure 1-12.—Hacksaws.

distance between the two pins that hold the blade in place.

Hacksaw blades are made of high-grade tool steel, hardened and tempered. There are two types, the all-hard and the flexible. All-hard blades are hardened throughout, whereas only the teeth of the flexible blades are hardened. Hacksaw blades are about 1/2-inch wide, have from 14 to 32 teeth per inch, and are from 8 to 16 inches long. The blades have a hole at each end, which hooks to a pin in the frame. All hacksaw frames, which hold the blades either parallel or at right angles to the frame, are provided with a wingnut or screw to permit tightening or removing the blade.

The SET in a saw refers to how much the teeth are pushed out in opposite directions from the sides of the blade. The four different kinds of set are the ALTERNATE set, DOUBLE ALTERNATE set, RAKER set, and WAVE set. Three of these are shown in figure 1-13.

The teeth in the alternate set are staggered, one to the left and one to the right throughout the length of the blade. On the double alternate set blade, two adjoining teeth are staggered to the right, two to the left, and so on. On the raker set blade, every third tooth remains straight and the other two are set alternately. On the wave (undulated) set blade, short sections of teeth are bent in opposite directions.

Using Hacksaws

The hacksaw is often used improperly. Although it can be used with limited success by an inexperienced person, a little thought and study given to its proper use will result in faster and better work and in less dulling and breaking of blades.

Good work with a hacksaw depends not only upon the proper use of the saw but also upon the proper

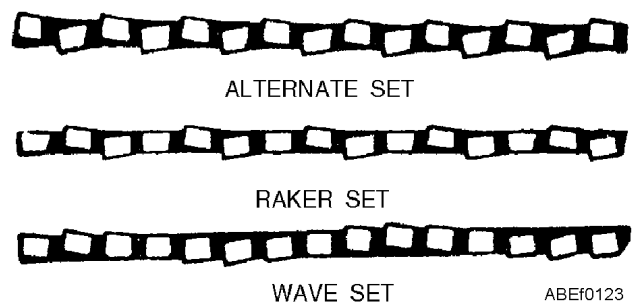

Figure 1-13.—"Set" of hacksaw-blade teeth.

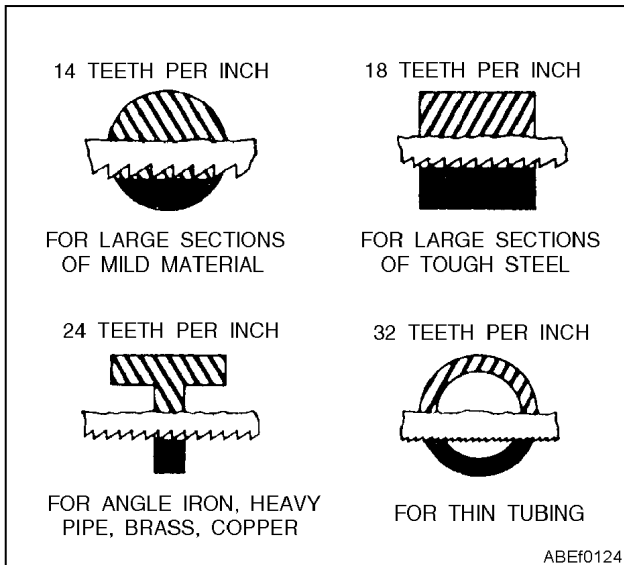

Figure 1-14.—Selecting the proper hacksaw blade.

selection of the blades for the work to be done. Figure 1-14 will help you select the proper blade to use when sawing metal with a hacksaw. Coarse blades, with fewer teeth per inch, cut faster and are less likely to choke up with chips. However, finer blades, with more teeth per inch, are necessary when thin sections are being cut. The selection should be made so that, as each tooth starts its cut, the tooth ahead of it will still be cutting.

To make the cut, first install the blade in the hacksaw frame (fig. 1-15) so the teeth point away from the handle of the hacksaw. (Hand hacksaws cut on the push stroke.) Tighten the wingnut until the blade is definitely under tension. This helps make straight cuts.

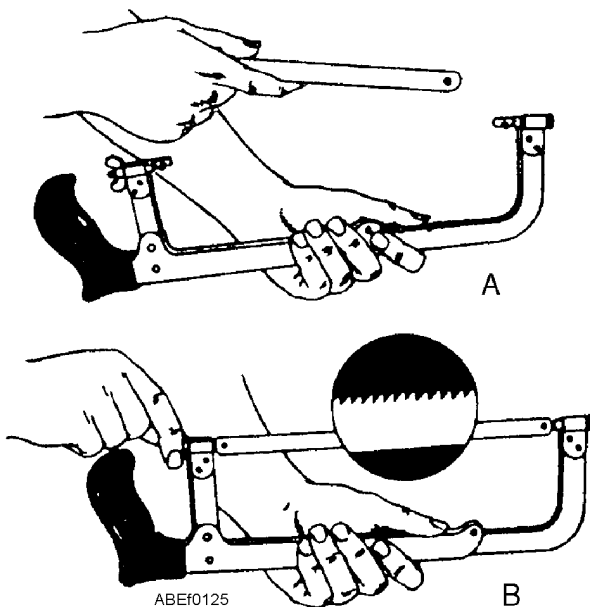

Figure 1-15.—Installing a hacksaw blade.

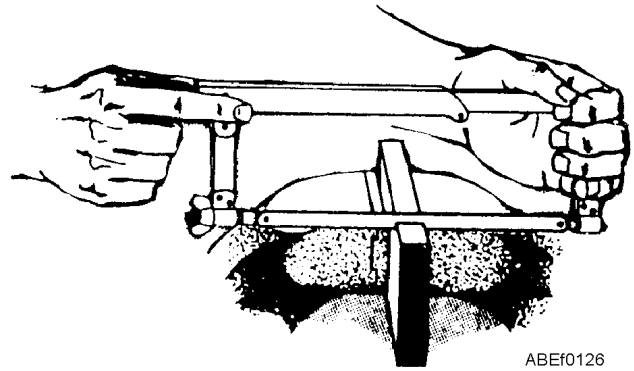

Figure 1-16.—Proper way to hold a hacksaw.

Place the material to be cut in a vise. A minimum of overhang will reduce vibration, give a better cut, and lengthen the life of the blade. Have the layout line outside of the vise jaw so that the line is visible while you work.

The proper method of holding the hacksaw is depicted in figure 1-16. See how the index finger of the right hand, pointed forward, aids in guiding the frame.

When cutting, let your body sway ahead and back with each stroke. Apply pressure on the forward stroke, which is the cutting stroke, but not on the return stroke. From 40 to 50 strokes per minute is the usual speed. Long, slow, steady strokes are preferred.

For long cuts, rotate the blade in the frame so that the length of the cut is not limited by the depth of the frame. Hold the work with the layout line close to the vise jaws, raising the work in the vise as the sawing proceeds.

To remove a frozen nut with a hacksaw, saw into the nut, as shown in figure 1-17, starting the blade close to the threads on the bolt or stud and parallel to one face of the nut, as shown in view A. Saw parallel to the bolt until the teeth of the blade almost reach the lockwasher. Lockwashers are hard and will ruin hacksaw blades, so do not try to saw them. View B shows when to stop sawing. Then, with a cold chisel and hammer, remove this one side of the nut completely by opening the saw

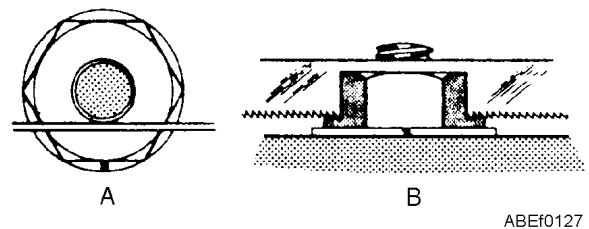

Figure 1-17.—Removing a frozen nut with a hacksaw.

kerf. Put an adjustable wrench across this new flat and the one opposite, and again try to remove the frozen nut. Since very little original metal remains on this one side of the nut, the nut will either give or break away entirely and permit its removal.

To saw a wide kerf in the head of a cap screw or machine bolt, fit the hand hacksaw frame with two blades side by side, and with teeth lined up in the same direction. With slow, steady strokes, saw the slot approximately one-third the thickness of the head of the cap screw, as shown in figure 1-18. Such a slot will permit subsequent holding or turning with a screwdriver when it is impossible, due to close quarters, to use a wrench.

Hacksaw Safety

The main danger in using hacksaws is injury to your hand if the blade breaks. The blade will break if too much pressure is applied, when the saw is twisted, when the cutting speed is too fast, or when the blade becomes loose in the frame. Additionally, if the work is not tight in the vise, it will sometimes slip, twisting the blade enough to break it.

CHISELS

Chisels are tools that can be used for chipping or cutting metal. They are made from a good grade of tool steel and have a hardened cutting edge and beveled head. Chisels are classified according to the shape of their points, and the width of the cutting edge denotes their size. The most common shapes of chisels are the flat (cold chisel), cape, round nose, and diamond point (fig. 1-19).

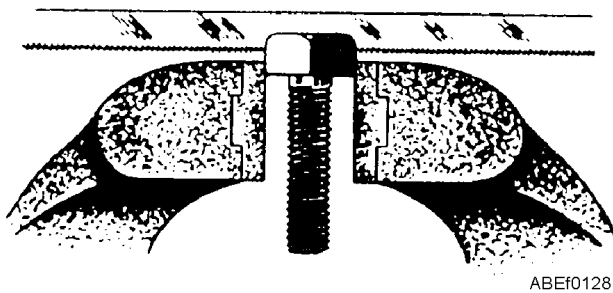

Figure 1-18.—Cutting a wide kerf in the head of a cap screw or bolt.

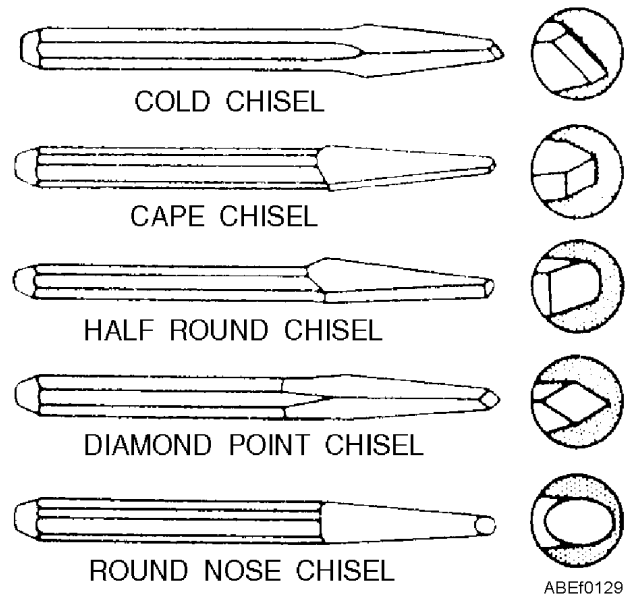

Figure 1-19.—Types of points on metal-cutting chisels.

The type of chisel most commonly used is the flat cold chisel, which serves to cut rivets, split nuts, chip castings, and cut thin metal sheets. The cape chisel is used for special jobs like cutting keyways, narrow grooves, and square corners. Round-nose chisels make circular grooves and chip inside corners. Finally, the diamond-point is used for cutting V-grooves and sharp corners.

As with other tools, there is a correct technique for using a chisel. Select a chisel that is large enough for the job. Be sure to use a hammer that matches the chisel; that is, the larger the chisel, the heavier the hammer. A heavy chisel will absorb the blows of a light hammer and will do virtually no cutting.

When using a chisel for chipping, always wear goggles to protect your eyes. If others are working close by, see that they are protected from flying chips by erecting a screen or shield to contain the chips. Remember that the time to take these precautions is before you start the job.

FILES

There are a number of different types of files in common use, and each type may range in length from 3 to 18 inches.

Grades

Files are graded according to the degree of fineness and whether they have single- or double-cut teeth. The difference is apparent when you compare the files in figure 1-20, view A.

Single-cut files have rows of teeth cut parallel to each other. These teeth are set at an angle of about 65 degrees with the centerline. You will use single-cut files for sharpening tools, finish filing, and drawfiling. They are also the best tools for smoothing the edges of sheet metal.

Files with crisscrossed rows of teeth are double-cut files. The double cut forms teeth that are diamond-shaped and fast cutting. You will use double-cut files for quick removal of metal and for rough work.

Files are also graded according to the spacing and size of their teeth, or their coarseness and fineness. Some of these grades are pictured in view B. In addition to the three grades shown, you may use some DEAD SMOOTH files, which have very fine teeth, and some ROUGH files, with very coarse teeth. The fineness or coarseness of file teeth is also influenced by the length of the file. (The length of a file is the distance from the tip to the heel, and does not include the tang view C.) When you have a chance, compare the actual size of the teeth of a 6-inch, single-cut smooth file and a 12-inch, single-cut smooth file; you will notice the 6-inch file has more teeth per inch than the 12-inch file.

Shapes

Files come in different shapes. Therefore, in selecting a file for a job, consider the shape of the finished work. Some of the cross-sectional shapes are shown in figure 1-20, view D.

TRIANGULAR files are tapered on all three sides. They are used to file acute internal angles and to clear out square corners. Special triangular files are used to file saw teeth.

MILL files are tapered in both width and thickness. One edge has no teeth and is known as a SAFE EDGE. Mill files are used for smoothing lathe work, drawfiling, and other fine, precision work. Mill files are always single-cut.

FLAT files are general-purpose files and may be either single- or double-cut. They are tapered in width and thickness. HARD files, not shown, are somewhat

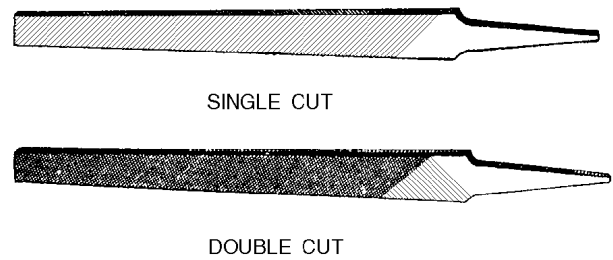

A. SINGLE AND DOUBLE-CUT FILES

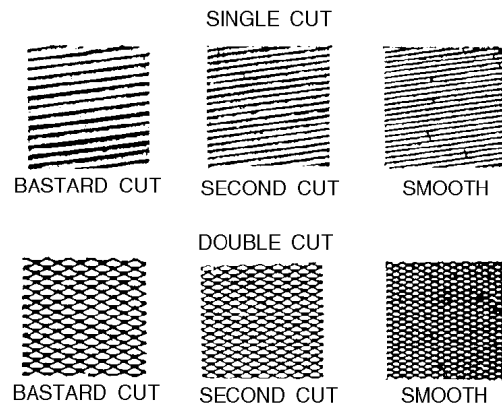

B. DESIGN AND SPACING OF FILE TEETH

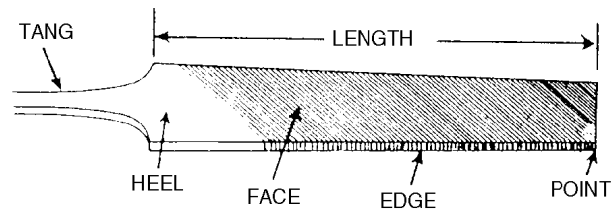

C. FILE NOMENCLATURE

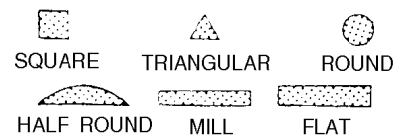

ABEf0130

Figure 1-20.—File information.

thicker than flat files. They taper slightly in thickness, but their edges are parallel.

The flat or hard files most often used are the double-cut for rough work and the single-cut smooth file for finish work.

SQUARE files are tapered on all four sides and are used to enlarge rectangular-shaped holes and slots. ROUND files serve the same purpose for round openings. Small round files are often called "rattail" files.

The HALF ROUND file is a general-purpose tool. The rounded side is used for curved surfaces, and the flat face on flat surfaces. When you file an inside curve, use a round or half-round file whose curve most nearly matches the curve of the work.

Kits of small files, often called "swiss pattern" or "jewelers" files, are used to fit parts of delicate mechanisms and for filing work on instruments. Handle these small files carefully because they break easily.

Filing Operations

Using a file is an operation that is nearly indispensable when working with metal. You may be crossfiling, drawfiling, using a file card, or even polishing metal. Let's examine these operations.

When you have finished using a file, it may be necessary to use an abrasive cloth or paper to finish the product. Whether this is necessary depends on how fine a finish you want on the work.

CROSSFILING.—Figure 1-21, view A, shows a piece of mild steel being crossfiled. This means that the file is being moved across the surface of the work in approximately a crosswise direction. For best results, keep your feet spread apart to steady yourself as you file with slow, full-length, steady strokes. The file cuts as you push it—ease up on the return stroke to keep from dulling the teeth. Keep your file clean.

View B shows the alternate positions of the file when an exceptionally flat surface is required. Using either position first, file across the entire length of the stock. Then, using the other position, file across the entire length of the stock again. Because the teeth of the file pass over the surface of the stock from two directions, the high spots and low spots will readily be visible after filing in both positions. Continue filing first in one position or direction and then the other until

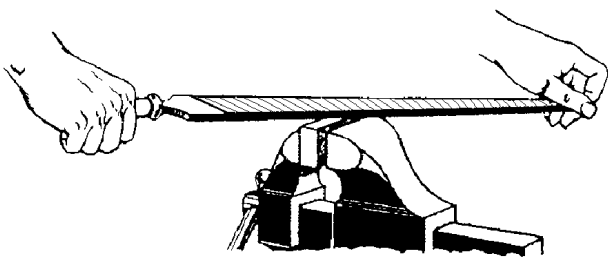

A. CROSSFILING A PIECE OF MILD STEEL

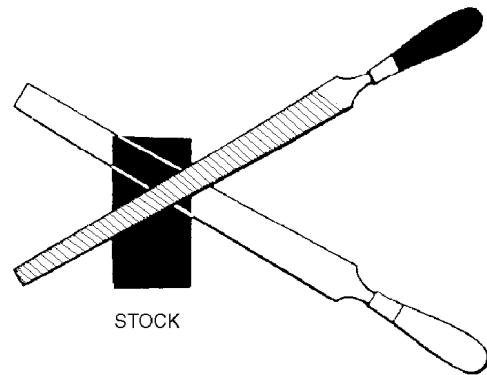

B. ALTERNATING POSITIONS WHEN FILING

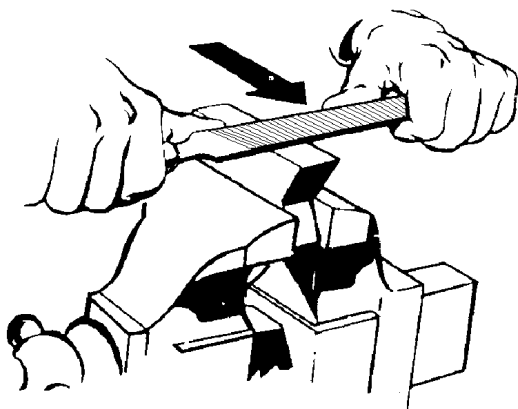

C. DRAWFILING A SMALL PART

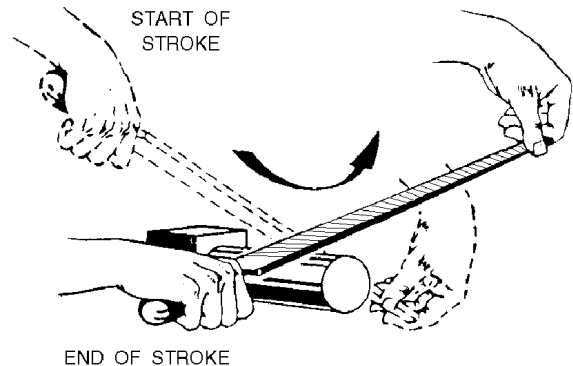

D. FILING ROUND METAL STOCK

ABEF0131

Figure 1-21.—Filing operations.

the surface has been filed flat. Test the flatness with a straightedge or with prussian blue and a surface plate.

DRAWFILING.—Drawfiling produces a finer surface finish and usually a flatter surface than crossfiling. Small parts, as shown in view C, are best held in a vise. Hold the file as shown in the figure; notice that the arrow indicates that the cutting stroke is away from you when the handle of the file is held in the right hand. If the handle is held in the left hand, the

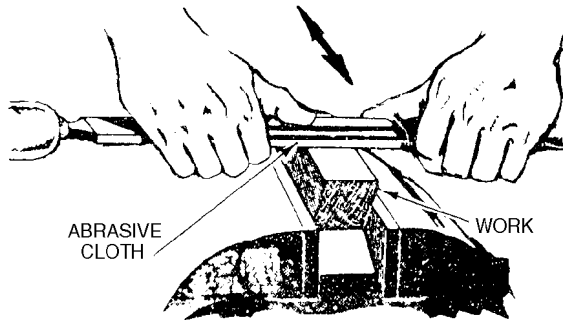

A. POLISHING METAL WITH ABRASIVE CLOTH WRAPPED AROUND A FILE

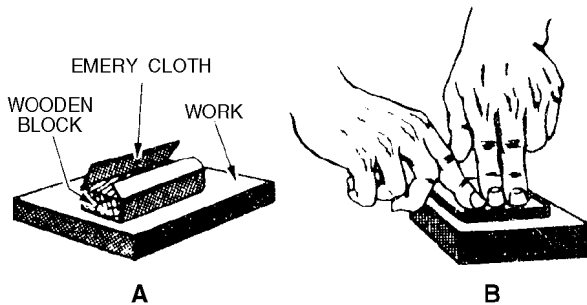

B. ALTERNATE METHODS FOR POLISHING METAL SURFACE

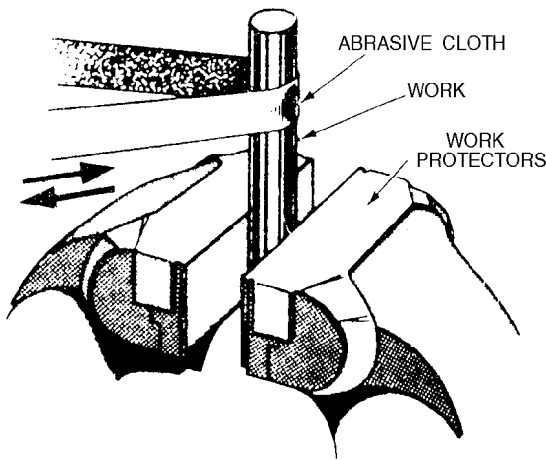

C. POLISHING ROUND METAL STOCK

ABEF0132

Figure 1-22.—Polishing operations.

cutting stroke will be toward you. Lift the file away from the surface of the work on the return stroke. When drawfiling will no longer improve the surface texture, wrap a piece of abrasive cloth around the file and polish the surface as shown in figure 1-22, view A.

USE OF FILE CARD.—As you file, the teeth of the file may "clog up" with some of the metal filings and scratch your work. This condition is known as **PINNING**. You can prevent pinning by keeping the file teeth clean. Rubbing chalk between the teeth will help prevent pinning, too, but the best method is to clean the file frequently with a **FILE CARD** or brush. A file card (fig. 1-23) has fine wire bristles. Brush with a pulling motion, holding the card parallel to the rows of teeth.

Always keep the file clean, whether you're filing mild steel or other metals. Use chalk liberally when filing nonferrous metals.

FILING ROUND-METAL STOCK.—Figure 1-21, view D, shows that as a file is passed over the surface of round work, its angle with the work is changed. This results in a rocking motion of the file as it passes over the work. This rocking motion permits all the teeth on the file to make contact and cut as they pass over the work's surface, thus tending to keep the file much cleaner and thereby doing better work.

POLISHING A FLAT-METAL SURFACE.—When polishing a flat metal surface, first draw file the surface as shown in figure 1-21, view C. Then, when the best possible drawfiled surface has been obtained, proceed with abrasive cloth, often called emery cloth. Select a grade of cloth suited to the drawfiling. If the drawfiling was well done, only a fine cloth will be needed to do the polishing.

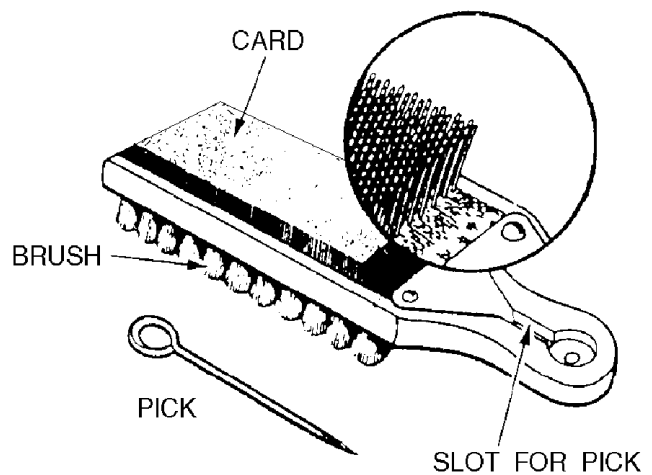

ABEF0133

Figure 1-23.—File card/brush cleaner.

If your cloth is in a roll and if the job you are polishing is the size that would be held in a vise, tear off a 6- or 8-inch length of the 1- or 2-inch width. If you are using sheets of abrasive cloth, tear off a strip from the long edge of the 8- by 11-inch sheet.

Wrap the cloth around the file (fig. 1-22, view A) and hold the file as you would for drawfiling. Hold the end of the cloth in place with your thumb. In polishing, apply a thin film of lubricating oil on the surface being polished and use a double stroke with pressure on both the forward and the backward strokes. Note that this is different from the drawfiling stroke in which you cut with the file in only one direction.

When further polishing does not appear to improve the surface, you are ready to use the next finer grade of cloth. Before changing to the finer grade, however, reverse the cloth so that its back is toward the surface being polished.

Work the reversed cloth back and forth in the abrasive-laden oil as an intermediate step between grades of abrasive cloth. Then, with the solvent available in your ship, clean the job thoroughly before proceeding with the next finer grade of cloth. Careful cleaning between grades helps to ensure freedom from scratches.

For the final polish, use a strip of crocus cloth—first the face and then the back—with plenty of oil. When polishing is complete, again carefully clean the job with a solvent and protect it with oil or other means, from rusting.

In figure 1-22, A of view B shows another way to polish, in which the abrasive cloth is wrapped around a block of wood. In B of view B, the cloth has simply been folded to form a pad, from which a worn, dull surface can be removed by simply tearing it off to expose a new surface.

POLISHING ROUND-METAL STOCK.—In figure 1-22, view C, a piece of round stock is being polished with a strip of abrasive cloth, which is "seesawed" back and forth as it is guided over the surface being polished.

Remember that the selection of grades of abrasive cloth, the application of oil, and the cleaning between grades applies to polishing, regardless of how the cloth is held or used.

Care of Files

A new file should be broken in carefully by using it first on brass, bronze, or smooth cast iron. Just a few of the teeth will cut at first, so use a light pressure to prevent tooth breakage. Do not break in a new file by using it first on a narrow surface.

Protect the file teeth by hanging your files in a rack when they are not in use or by placing them in drawers with wooden partitions. Your files should not be allowed to rust—keep them away from water and moisture. Avoid getting the files oily. Oil causes a file to slide across the work and prevents fast, clean cutting. Files that you keep in your toolbox should be wrapped in paper or cloth to protect their teeth and prevent damage to other tools.

Never use a file for prying or pounding. The tang is soft and bends easily. The body is hard and extremely brittle. Even a slight bend or a fall to the deck may cause a file to snap in two. Do not strike a file against the bench or vise to clean it—use a file card.

Safety

Never use a file unless it is equipped with a tight-fitting handle. If you use a file without the handle and it bumps something or jams to a sudden stop, the tang may be driven into your hand. To put a handle on a file tang, drill a hole in the handle, slightly smaller than the tang. Insert the tang end, and then tap the end of the handle to seat it firmly. Make sure you get the handle on straight.

TWIST DRILLS

Making a hole in a piece of metal is generally a simple operation, but in most cases an important, precise job. A large number of different tools and machines have been designed so that holes may be made speedily, economically, and accurately in all kinds of material.

To be able to use these tools efficiently, it is important that you become acquainted with them. The most common tool for making holes in metal is the twist drill. It consists of a cylindrical piece of steel with spiral grooves. One end of the cylinder is pointed, while the other end is shaped so that it may be attached to a drilling machine. The grooves, usually called FLUTES, may be cut into the steel cylinder, or the flutes may be formed by twisting a flat piece of steel into a cylindrical shape.

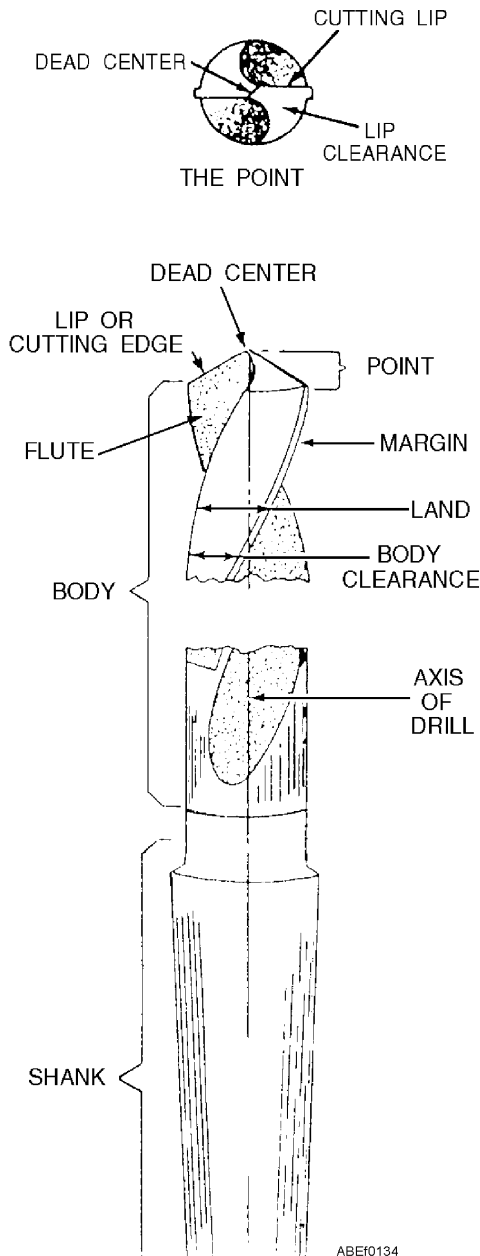

Figure 1-24.—Twist drill nomenclature.

The principal parts of a twist drill are the body, the shank, and the point (fig. 1-24). The dead center of a drill is the sharp edge at the extreme tip end of the drill. It is formed by the intersection of the cone-shaped surfaces of the point and should always be the exact center of the axis of the drill. The point of the drill should not be confused with the dead center. The point is the entire cone-shaped surface at the end of the drill.

The lip or cutting edge of a drill is that part of the point that actually cuts away the metal when drilling a hole. It is ordinarily as sharp as the edge of a knife. There is a cutting edge for each flute of the drill.

The shank is the part of the drill that fits into the socket, spindle, or chuck of the drill press. Several types exist (fig. 1-25).

The maintenance of twist drills and more about how to use them on specific jobs are discussed later.

REVIEW QUESTIONS

- Q7. Identify the different types of metal-cutting tools.
- Q8. What are hawks-bill snips used for?
- Q9. What are hacksaws used for?
- Q10. What are taps and dies used for?

WRENCHES

LEARNING OBJECTIVES: Identify the different types of wrenches. Describe the uses of different types of wrenches. List the safety precautions that apply to wrenches.

A wrench is a basic tool that is used to exert a twisting force on bolt heads, nuts, studs, and pipes. The special wrenches designed to do certain jobs are, in most cases, variations of the basic wrenches that are described in this section.

The best wrenches are made of chrome vanadium steel. Wrenches made of this material are lightweight and almost unbreakable. This is an expensive material, however, so the most common wrenches found in the Navy are made of forged carbon steel or molybdenum steel. These latter materials make good wrenches, but they are generally built a little heavier and bulkier to achieve the same degree of strength as chrome vanadium steel.

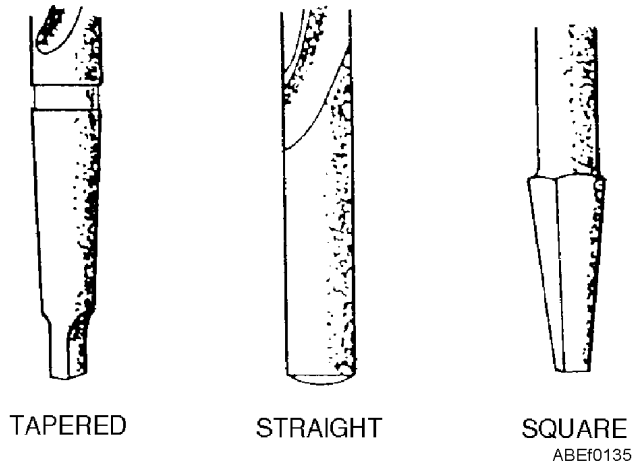

Figure 1-25.—Representative shanks.

The size of any wrench used on bolt heads or nuts is determined by the size of the opening between the jaws of the wrench. The opening of a wrench is manufactured slightly larger than the bolt head or nut that it is designed to fit. Hex-nuts (six-sided) and other types of nut or bolt heads are measured across opposite flats (fig. 1-26). A wrench that is designed to fit a 3/8-inch nut or bolt usually has a clearance of from 5 to 8 thousandths of an inch. This clearance allows the wrench to slide on and off the nut or bolt with a minimum of "play." If the wrench is too large, the points of the nut or bolt head will be rounded and destroyed.

There are many types of wrenches. Each type is designed for a specific use. Let's discuss some of them.

OPEN-END WRENCHES

Solid, nonadjustable wrenches with openings in one or both ends are called open-end wrenches. (See fig. 1-26.) Usually they come in sets of from 6 to 10 wrenches, with sizes ranging from 5/16 to 1 inch. Wrenches with small openings are usually shorter than wrenches with large openings. This proportions the lever advantage of the wrench to the bolt or stud and helps prevent wrench breakage or damage to the bolt or stud. One exception exists.

Hydraulic piping installations for catapult and arresting gear are often in close spaces. During certain

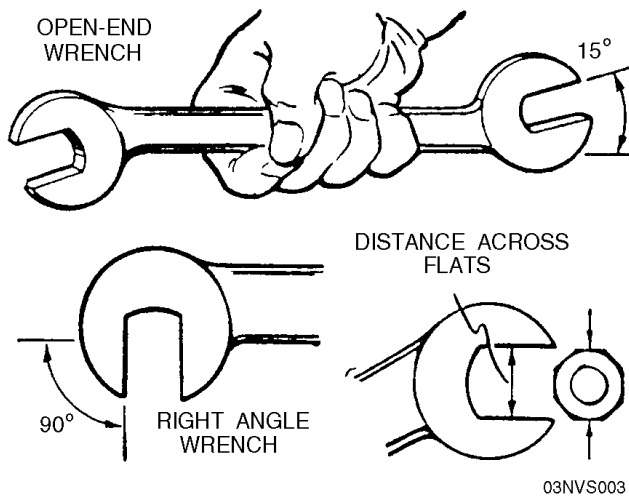

Figure 1-26.—Open-end wrenches.

phases of hydraulic maintenance it may be impossible to swing an ordinary wrench because of its length. Ordinary wrenches that are normally available increase in length as their size increases. Thus, when a large-size wrench is needed, the length of the wrench sometimes prevents its use, due to the space available to swing the wrench. The Bonney wrench, shown in figure 1-27, is an open-end wrench that may be used to great advantage because of its thickness and short length. This wrench is normally procured in the larger sizes, although it is available in a range of sizes to fit most hydraulic fittings.

Open-end wrenches may have their jaws parallel to the handle or at angles anywhere up to 90 degrees. The average angle is 15 degrees (fig. 1-26). This angular displacement variation permits selection of a wrench suited for places where there is room to make only a part of a complete turn of a nut or bolt. If the wrench is turned over after the first swing, it will fit on the same flats and turn the nut farther. After two swings on the wrench, the nut is turned far enough so that a new set of flats are in position for the wrench, as shown in figure 1-28.

Handles are usually straight, but may be curved. Those with curved handles are called S-wrenches. Other open-end wrenches may have offset handles. This allows the head to reach nut or bolt heads that are sunk below the surface.

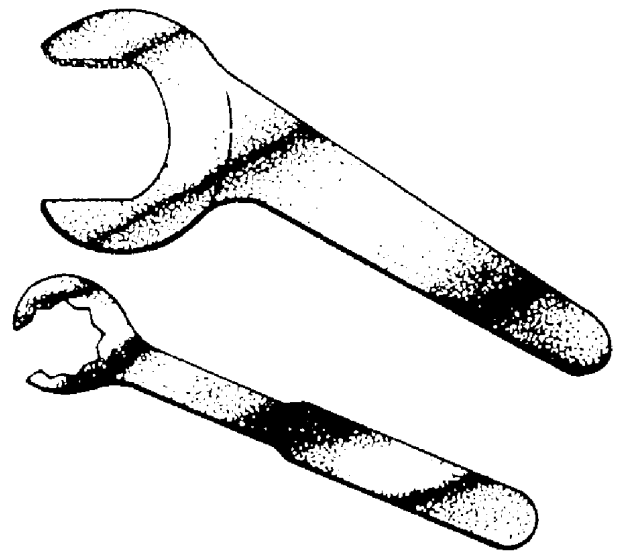
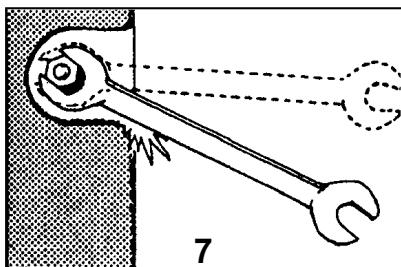
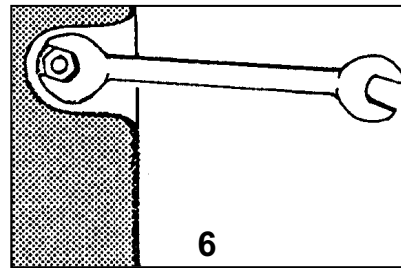
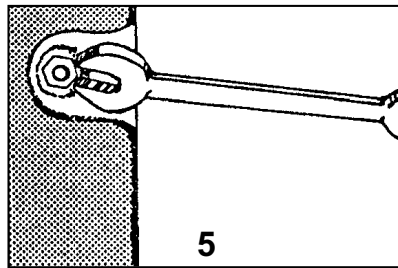
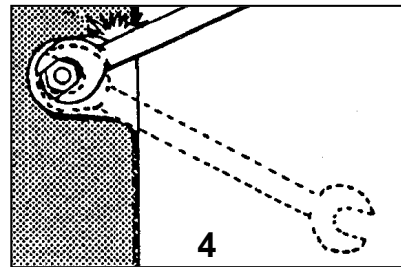
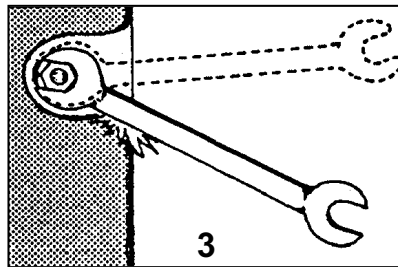
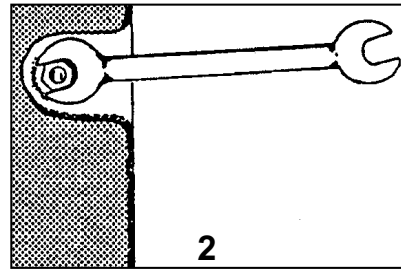
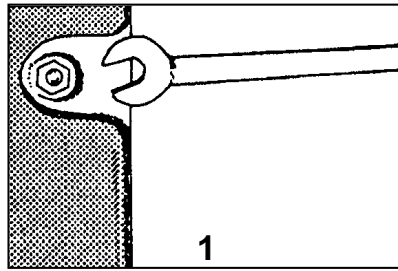

Figure 1-27.—Bonney wrenches.



1. WRENCH, WITH OPENING SLOPING TO THE LEFT, ABOUT TO BE PLACED ON NUT.
2. WRENCH POSITIONED AND READY TO TIGHTEN NUT. NOTE THAT SPACE FOR SWINGING THE WRENCH IS LIMITED.
3. WRENCH HAS BEEN MOVED CLOCKWISE TO TIGHTEN THE NUT AND NOW STRIKES THE CASTING, WHICH PREVENTS FURTHER MOVEMENT.
4. WRENCH IS REMOVED FROM NUT AND TURNED COUNTER CLOCKWISE TO BE PLACED ON THE NEXT SET OF FLATS ON NUT. BUT CORNER OF CASTING PREVENTS WRENCH FROM FITTING ONTO THE NUT.
5. WRENCH IS BEING TURNED OVER SO THAT WRENCH OPENING WILL SLOPE TO THE RIGHT.
6. IN THIS POSITION, THE WRENCH WILL FIT THE NEXT TWO FLATS ON THE NUT.
7. WRENCH NOW IS PULLED CLOCKWISE TO FURTHER TIGHTEN NUT UNTIL WRENCH AGAIN STRIKES CASTING. BY REPEATING THE PROCEDURE, THE NUT CAN BE TURNED UNTIL IT IS TIGHT.

Figure 1-28.—Use of open-end wrench.

ABEf0105

The non-adjustable union nut wrench (fig. 1-29) is used to assemble and disassemble launch valve piping union nuts. These special open-end wrenches are designed to pass over the piping and then slide onto the union nut to fully engage five of the six flats, thus reducing the probability of damaging the nuts.

NOTE

These non-adjustable union nut wrenches are the preferred type for launch valve piping. Under **no** circumstances should any other type of adjustable or open-end wrench be used on launch valve piping fittings.

BOX WRENCHES

Box wrenches (fig. 1-30) are safer than open-end wrenches since there is less likelihood they will slip off the work. They completely surround, or box, a nut or bolt head.

The most frequently used box wrench has 12 points or notches arranged in a circle in the head and can be used with a minimum swing angle of 30 degrees. Six- and eight-point wrenches are used for heavy duty; twelve-point for medium, and sixteen for light-duty only.

One advantage of the 12-point construction is the thin wall. It is more suitable for turning nuts that are hard to get at with an open-end wrench. Another advantage is that the wrench will operate between obstructions where the space for handle swing is limited. A very short swing of the handle will turn the nut far enough to allow the wrench to be lifted and the next set of points fitted to the corners of the nut.

One disadvantage of the box-end wrench is the time loss that occurs whenever a craftsman has to lift the wrench off and place it back on the nut in another

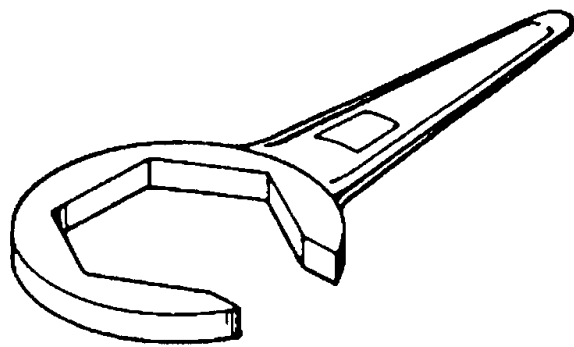

ABEf0106

Figure 1-29.—Nonadjustable union nut wrench.



ABEf0107

Figure 1-30.—12-point box-end wrench.

position when there is insufficient clearance to spin the wrench in a full circle.

COMBINATION WRENCH

After a tight nut is broken loose, it can be unscrewed much more quickly with an open-end wrench than with a box-wrench. A combination box-open end wrench (fig. 1-31) comes in handy in a situation of the type. You can use the box-end for breaking nuts loose or for snuggling them down, and the open-end for faster turning.

The box-end portion of the wrench can be designed with an offset in the handle. Notice in figure 1-31 how the 15-degree offset allows clearance over nearby parts.

The correct use of open-end and box-end wrenches can be summed up in a few simple rules, most important of which is to be sure that the wrench properly fits the nut or bolt head.

When you have to pull hard on the wrench, as in loosening a tight nut, make sure the wrench is seated squarely on the flats of the nut.

Pull on the wrench—DO NOT PUSH. Pushing a wrench is a good way to skin your knuckles if the wrench slips or the nut breaks loose unexpectedly. If it is impossible to pull the wrench and you must push, do it with the palm of your hand and hold your palm open.

Only actual practice will tell you if you are using the right amount of force on the wrench. The best way to tighten a nut is to turn it until the wrench has a firm, solid "feel." This will turn the nut to proper tightness without stripping the threads or twisting off the bolt. This "feel" is developed by experience alone. Practice until you have mastered the "feel."

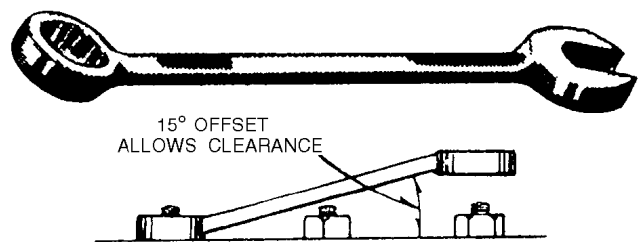

ABEf0108

Figure 1-31.—Offset combination wrench.

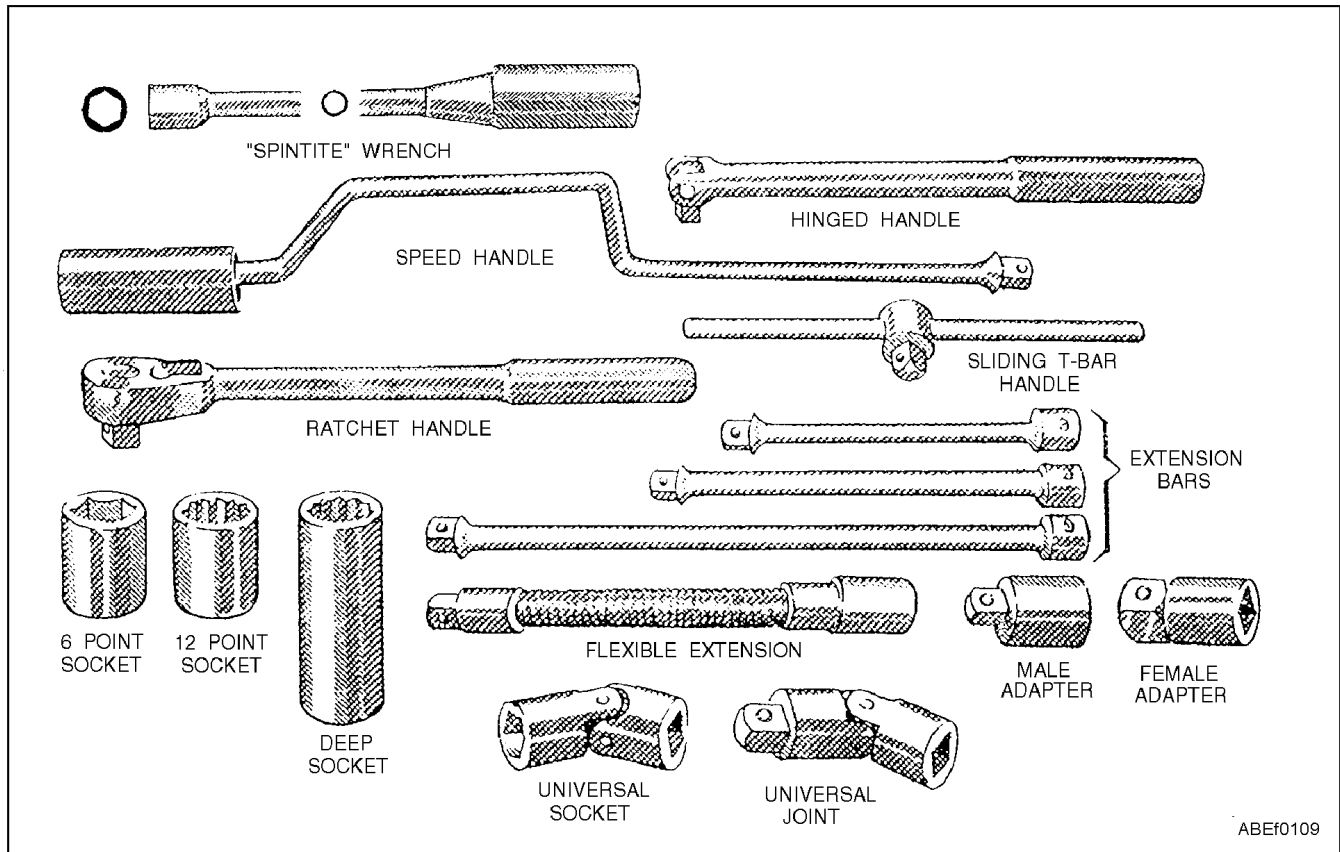

Figure 1-32.—Socket set components.

SOCKET WRENCH

The socket wrench is one of the most versatile wrenches in the toolbox. Basically, it consists of a handle and a socket-type wrench that can be attached to the handle.

The "Spintite" wrench, shown in figure 1-32, is a special type of socket wrench. It has a hollow shaft to accommodate a bolt protruding through a nut, has a hexagonal head, and is used like a screwdriver. It is supplied in small sizes only and is useful for assembly

and electrical work. When used for the latter purpose, it must have an insulated handle.

A complete socket wrench set consists of several types of handles along with bar extensions, adapters, and a variety of sockets (fig. 1-32).

Sockets

A socket (fig. 1-33) has a square opening cut in one end to fit a square drive lug on a detachable handle. In the other end of the socket is a 6-point or 12-point

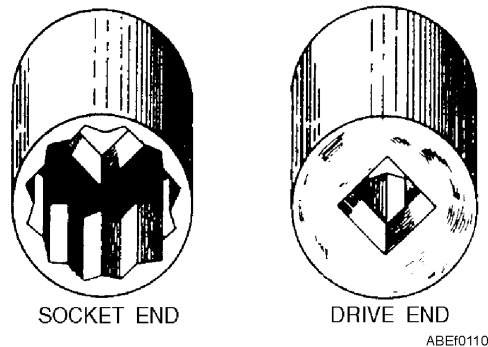

Figure 1-33.—12-point sockets.

opening, very much like the opening in the box-end wrench. The 12-point socket needs to be swung only half as far as the 6-point socket before it has to be lifted and fitted on the nut for a new grip. It can therefore be used in closer quarters where there is less room to move the handle. (A ratchet handle eliminates the necessity of lifting the socket and refitting it on the nut again and again.)

Sockets are classified by size according to two factors. One is the size of the square opening, which fits on the square drive lug of the handle. This size is known as the drive size. The other is the size of the opening in the opposite end, which fits the nut or bolt. The standard toolbox can be outfitted with sockets having 1/4-, 3/8-, and 1/2-inch-square drive lugs. Larger sets are usually available in the tool room for temporary checkout. The openings that fit onto the bolt or nut are usually graduated in 1/16-inch sizes. Sockets are also made in deep lengths to fit over spark plugs and long bolt ends.

Socket Handles

There are four types of handles used with these sockets. (See fig. 1-32.) Each type has special advantages, and the experienced worker chooses the one best suited for the job at hand. The square driving lug on the socket wrench handles has a spring-loaded ball that fits into a recess in the socket receptacle. This mated ball-recess feature keeps the socket engaged with the drive lug during normal usage. A slight pull on the socket, however, disassembles the connection.

RATCHET.—The ratchet handle has a reversing lever that operates a pawl (or dog) inside the head of the tool. Pulling the handle in one direction causes the pawl to engage the ratchet teeth and turn the socket. Moving the handle in the opposite direction causes the pawl to slide over the teeth, permitting the handle to back up without moving the socket. This allows rapid turning of the nut or bolt after each partial turn of the handle. With the reversing lever in one position, the handle can be used for tightening. In the other position, it can be used for loosening.

HINGED HANDLE.—The hinged handle is also very convenient. To loosen tight nuts, swing the handle

at right angles to the socket. This gives the greatest possible leverage. After loosening the nut to the point where it turns easily, move the handle into the vertical position and then turn the handle with the fingers.

SLIDING T-BAR HANDLE.—When you are using the sliding bar or T-handle, the head can be positioned anywhere along the sliding bar. Select the position that is needed for the job at hand.

SPEED HANDLE.—The speed handle is worked like the woodworker's brace. After the nuts are first loosened with the sliding bar handle or the ratchet handle, the speed handle can be used to remove the nuts more quickly. In many instances the speed handle is not strong enough to be used for breaking loose or tightening the nut. The speed socket wrench should be used carefully to avoid damaging the nut threads.

Accessories

Several accessory items complete the socket wrench set. Extension bars of different lengths are made to extend the distance from the socket to the handle. A universal joint allows the nut to be turned with the wrench handle at an angle. Universal sockets are also available. The use of universal joints, bar extensions, and universal sockets in combination with appropriate handles makes it possible to form a variety of tools that will reach otherwise inaccessible nuts and bolts.

Another accessory item is an adapter, which allows you to use a handle having one size of drive and a socket having a different size drive. For example, a 3/8- by 1/4-inch adapter makes it possible to turn all 1/4-inch-square drive sockets with any 3/8-inch-square drive handle.

TORQUE WRENCHES

There are times when, for engineering reasons, a definite force must be applied to a nut or bolt head. In such cases a torque wrench must be used. For example, equal force must be applied to all the head bolts of an engine. Otherwise, one bolt may bear the brunt of the force of internal combustion and ultimately cause engine failure.

The three most commonly used torque wrenches are the deflecting beam, dial indicating, and micrometer setting types (fig. 1-34). When using the deflecting beam and the dial indicating torque wrenches, read the torque visually on a dial or scale mounted on the handle of the wrench.

To use the micrometer setting type, unlock the grip and adjust the handle to the desired setting on the micrometer-type scale, then relock the grip. Install the required socket or adapter to the square drive of the handle. Place the wrench assembly on the nut or bolt and pull in a clockwise direction with a smooth, steady motion. (A fast or jerky motion will result in an improperly torqued unit.) When the torque applied reaches the torque value, which is indicated on the handle setting, a signal mechanism will automatically issue an audible click, and the handle will release or "break," and move freely for a short distance. The release and free travel is easily felt, so there is no doubt about when the torquing process is complete.

Manufacturers' and technical manuals generally specify the amount of torque to be applied. To assure getting the correct amount of torque on the fasteners, it is important that the wrench be used properly according to manufacturer's instructions.

Use the torque wrench that will read about mid-range for the amount of torque to be applied. **BE SURE THE TORQUE WRENCH HAS BEEN CALIBRATED BEFORE YOU USE IT.** Remember, too, that the accuracy of torque-measuring depends a lot on how the threads are cut and the cleanliness of the threads. Make sure you inspect and clean the threads. If

the manufacturer specifies a thread lubricant, it must be used to obtain the most accurate torque reading. When using the deflecting beam or dial indicating wrenches, hold the torque at the desired value until the reading is steady.

Torque wrenches are delicate and expensive tools. The following precautions should be observed when using them:

1. When using the micrometer setting type, do not move the setting handle below the lowest torque setting. However, it should be placed at its lowest setting before it is returned to storage.
2. Do not use the torque wrench to apply greater amounts of torque than its rated capacity.
3. Do not use the torque wrench to loosen bolts that have been previously tightened.
4. Do not drop the wrench. If a torque wrench is dropped, its accuracy will be affected.
5. Do not apply a torque wrench to a nut that has been tightened. Back off the nut one turn with a nontorque wrench and retighten to the correct torque with the indicating torque wrench.
6. Calibration intervals have been established for all torque tools used in the Navy. When a tool is calibrated by a qualified calibration activity at a shipyard, tender, or repair ship, a label showing the next calibration due date is attached to the handle. This date should be checked before a torque tool is used to ensure that it is not overdue for calibration.

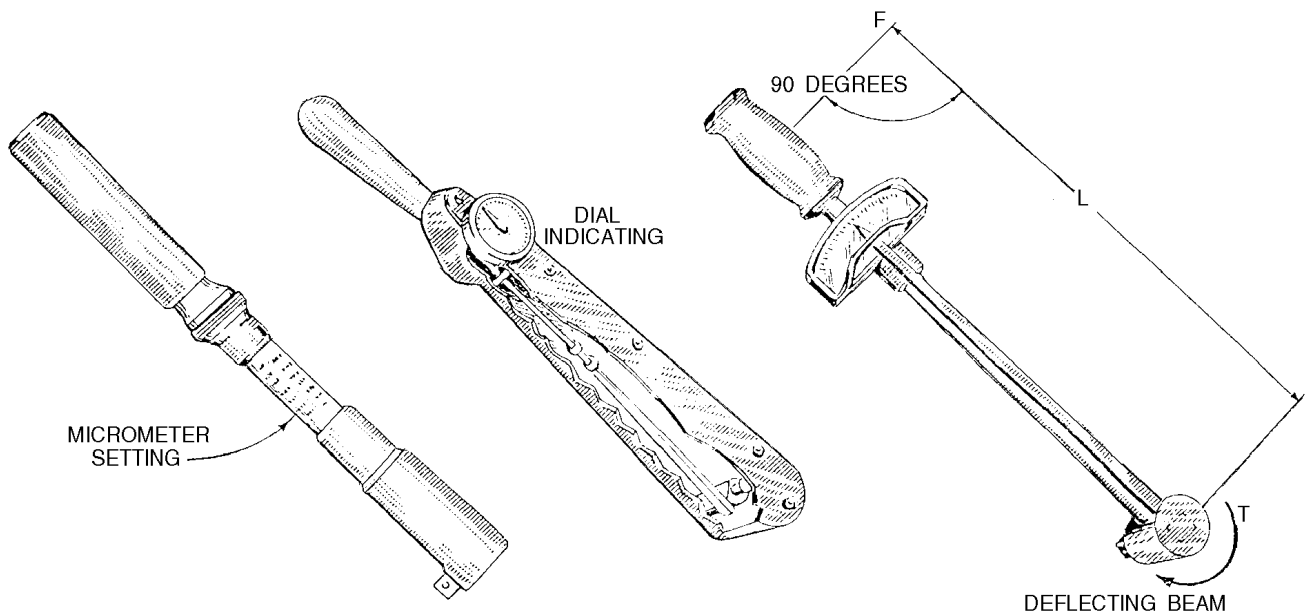

Figure 1-34.—Torque wrenches.

03NVS010

ADJUSTABLE WRENCHES

A handy all-round wrench that is generally included in every toolbox is the adjustable open-end wrench. This wrench is not intended to take the place of the regular solid open-end wrench. Additionally, it is not built for use on extremely hard-to-turn items. Its usefulness is achieved by being capable of fitting odd-sized nuts. This flexibility is achieved although one jaw of the adjustable open-end wrench is fixed, because the other jaw is moved along a slide by a thumbscrew adjustment (fig. 1-35). By turning the thumbscrew, you can adjust the jaw opening to fit various sizes of nuts.

Adjustable wrenches are available in varying sizes, normally ranging from 4 to 24 inches in length. The size of the wrench selected for a particular job is dependent upon the size of the nut or bolt head to which the wrench is to be applied.

Adjustable wrenches are often called "knuckle busters," because mechanics frequently suffer these consequences as a result of improper usage of these tools. To avoid accidents, follow four simple steps. First, choose a wrench of the correct size; that is, do not pick a large 12-inch wrench and adjust the jaw for use on a 3/8-inch nut. This could result in a broken bolt and a bloody hand. Second, be sure the jaws of the correct-size wrench are adjusted to fit snugly on the nut. Third, position the wrench around the nut until the nut is all the way into the throat of the jaws. If the wrench is

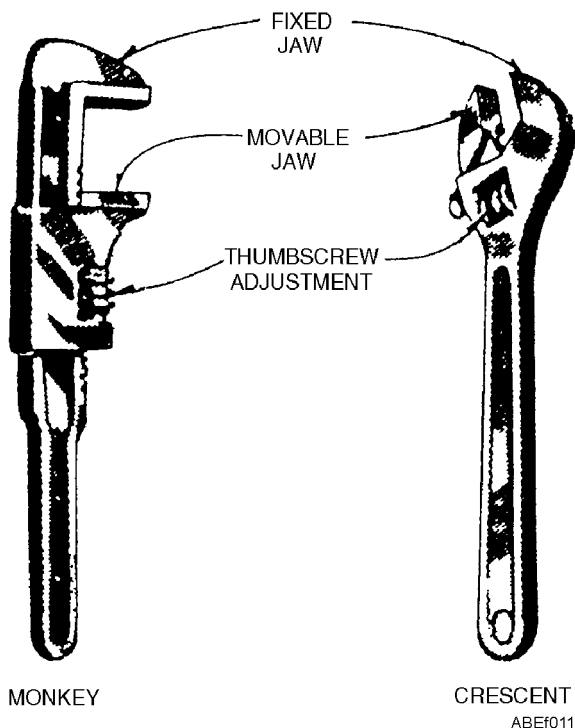

Figure 1-35.—Adjustable wrenches.

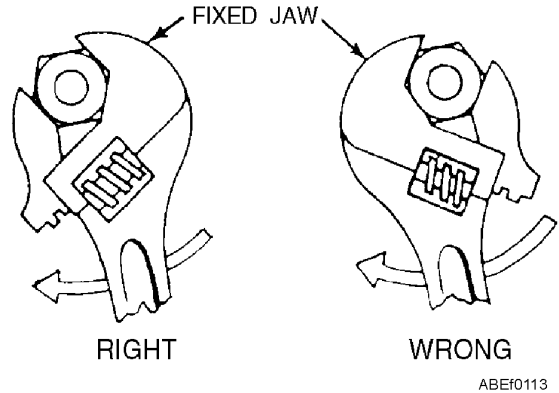

Figure 1-36.—Proper procedure for using adjustable wrenches.

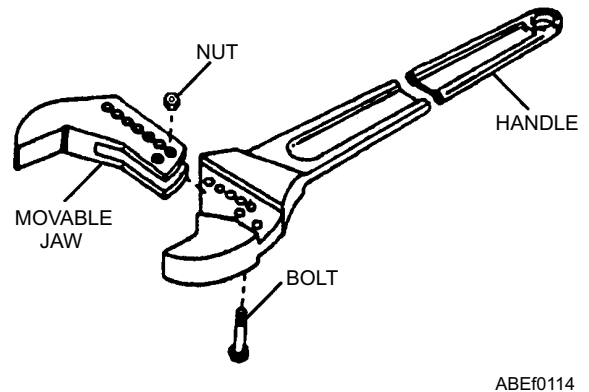

Figure 1-37.—Union nut wrench.

not used in this manner, the result is apt to be as bloody as before. Fourth, pull the handle toward the side having the adjustable jaw (fig. 1-36). This will prevent the adjustable jaw from springing open and slipping off the nut. If the location of the work will not allow for all four steps to be followed when using an adjustable wrench, then select another type of wrench for the job.

Union Nut Wrench

The adjustable union nut wrench (fig. 1-37) is used to assemble and disassemble pipe union nuts. The adjustable jaws are held in place by removable nut and bolt and is adjusted to proper size before each use.

In rotating or holding round work, an adjustable pipe wrench (Stillson) may be used (fig. 1-38). The

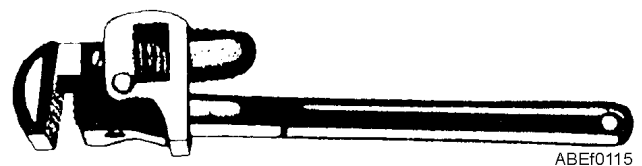

Figure 1-38.—Adjustable pipe wrench.

movable jaw on a pipe wrench is pivoted to permit a gripping action on the work. This tool must be used with discretion, as the jaws are serrated and always make marks on the work unless adequate precautions are observed. The jaws should be adjusted so the bite on the work will be taken at about the center of the jaws.

Strap Wrench

The strap wrench (fig. 1-39) is used for turning pipe or cylinders where you do not want to mar the surface of the work. To use this wrench, the webbed strap is placed around the pipe and passed through the slot in the metal body of the wrench. The strap is then pulled up tight; and as the mechanic turns the wrench in the desired direction, the webbed strap tightens further around the pipe. This gripping action causes the pipe to turn.

SPANNER WRENCHES

Many special nuts are made with notches cut into their outer edge. For these nuts a hook spanner (fig. 1-40) is required. This wrench has a curved arm with a lug or hook on the end. This lug fits into one of the notches of the nut, and the handle is turned to loosen or tighten the nut. This spanner may be made for just one particular size of notched nut, or it may have a hinged arm to adjust it to a range of sizes.

Another type of spanner is the pin spanner. Pin spanners have a pin in place of a hook. This pin fits into a hole in the outer part of the nut.

Face pin spanners are designed so that the pins fit into holes in the face of the nut (fig. 1-40).

When you use a spanner wrench, you must make sure the pins, lugs, or hooks make firm contact with the nut while the turning force is transferred from the wrench to the nut. If this is not done, damage will result to tools or equipment or injury to personnel.

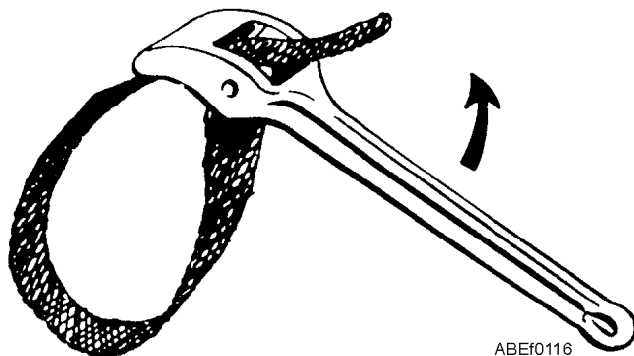
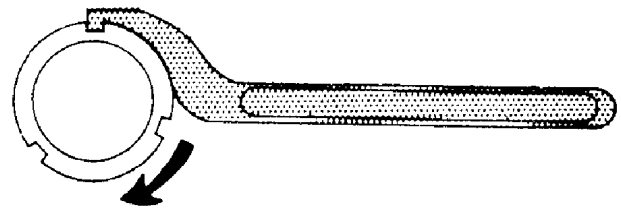

Figure 1-39.—Strap wrench.

ABEF0116



HOOK SPANNER



ADJUSTABLE HOOK SPANNER



PIN SPANNER

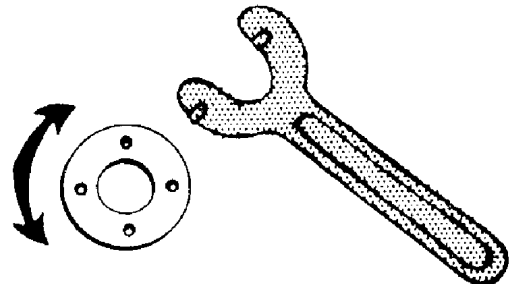

FACE PIN SPANNER

ABEF0117

Figure 1-40.—General-purpose spanner wrenches.

SETSCREW WRENCHES (ALLEN AND BRISTOL)

In some places it is desirable to use recessed heads on setscrews and capscrews. One type of screw (Allen) is used extensively on office machines and in machine shops. The other type (Bristol) is used infrequently.

Recessed-head screws usually have a hex-shaped (six-sided) recess. To remove or tighten this type of screw requires a special wrench that will fit in the recess. This wrench is called an Allen-type wrench. Allen wrenches are made from hexagonal L-shaped

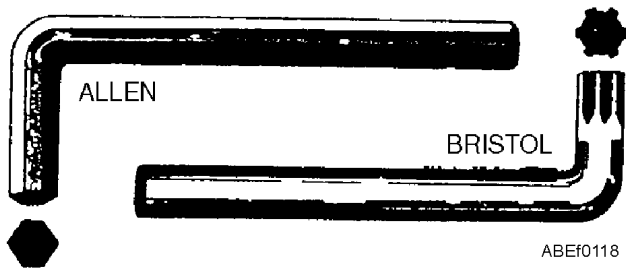

Figure 1-41.—Allen- and Bristol-type wrenches.

bars of tool steel (fig. 1-41). They generally range in size up to 3/4 inch. When using the Allen-type wrench, make sure you use the correct size to prevent rounding or spreading the head of the screw. A snug fit within the recessed head of the screw is an indication that you have the correct size.

The Bristol wrench is made from round stock. It is also L-shaped, but one end is fluted to fit the flutes or little splines in the Bristol setscrew (fig. 1-41).

SAFETY RULES FOR WRENCHES

There are a few basic rules that you should keep in mind when using wrenches. They are as follows:

- Always use a wrench that fits the nut properly.
- Keep wrenches clean and free from oil. Otherwise they may slip, resulting in possible serious injury to you or damage to the work.
- Do not increase the leverage of a wrench by placing a pipe over the handle. Increased leverage may damage the wrench or the work.
- Provide some sort of kit or case for all wrenches. Return them to the case at the completion of each job. This saves time and trouble and aids selection of tools for the next job. Most

important, it eliminates the possibility of leaving them where they can cause injury to personnel or damage to equipment.

- Determine which way a nut should be turned before trying to loosen it. Most nuts are turned counterclockwise for removal. This may seem obvious, but even experienced people have been observed straining at the wrench in the tightening direction when they wanted to loosen the nut.
- Learn to select your wrenches to fit the type of work you are doing. If you are not familiar with these wrenches, make arrangements to visit a shop that has most of them, and get acquainted.

REVIEW QUESTIONS

- Q11. Identify the different types of wrenches.
- Q12. Describe the uses of different types of wrenches.
- Q13. List the safety precautions that apply to wrenches.

PLIERS

LEARNING OBJECTIVES: Identify the different types of pliers. Describe the uses of different types of pliers. Describe the proper care of pliers.

Pliers are made in many styles and sizes and are used to perform many different operations. Pliers are used for cutting purposes, as well as holding and gripping small articles in situations where it may be inconvenient or impossible to use hands. Figure 1-42 shows several different kinds.

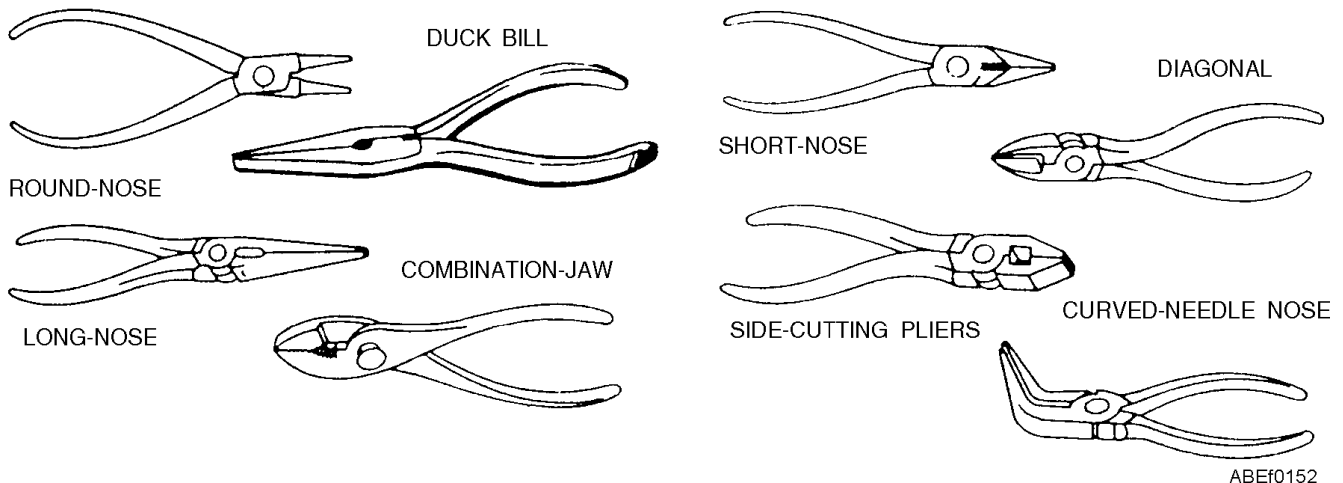

Figure 1-42.—Pliers.

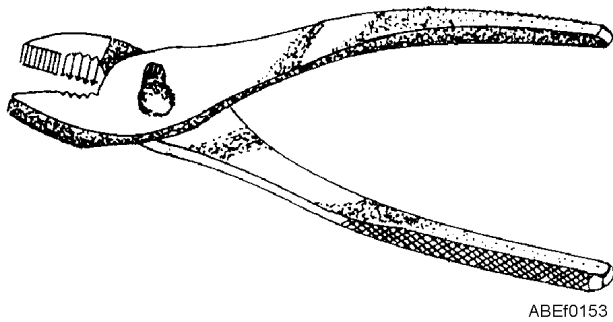

Figure 1-43.—Slip-joint pliers.

The combination pliers are handy for holding or bending flat or round stock. The long-nosed pliers are less rugged, and break easily if you use them on heavy jobs. Long-nosed pliers, commonly called needle-nose pliers, are especially useful for holding small objects in tight places and for making delicate adjustments. The round-nosed kind are handy when you need to crimp sheet metal or form a loop in a wire. The diagonal cutting pliers, commonly called "diagonals" or "dikes," are designed for cutting wire and cotter pins close to a flat surface and are especially useful in the electronic and electrical fields. The duckbill pliers are used extensively in aviation areas.

Here are two important rules for using pliers:

1. Do not make pliers work beyond their capacity. The long-nosed kind is especially delicate. It is easy to spring or break them, or nick their edges. After that, they are practically useless.
2. Do not use pliers to turn nuts. In just a few seconds, a pair of pliers can damage a nut. Pliers must not be substituted for wrenches.

SLIP-JOINT PLIERS

Slip-joint pliers (fig. 1-43) are pliers with straight, serrated (grooved) jaws, and pivot where the jaws are fastened together to move to either of two positions to grasp small- or large-sized objects better.

Slip-joint combination pliers are pliers similar to the slip-joint pliers just described but with the

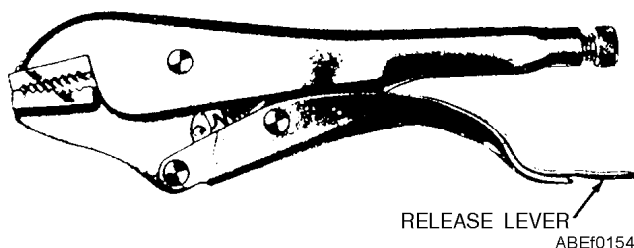

Figure 1-44.—Wrench pliers.

additional feature of a side cutter at the junction of the jaws. This cutter consists of a pair of square-cut notches, one on each jaw, which act like a pair of shears when an object is placed between them and the jaws closed.

WRENCH PLIERS

Wrench pliers (visegrips) (fig. 1-44), can be used for holding objects regardless of their shape. A screw adjustment in one of the handles makes them suitable for several different sizes. The jaws of wrench pliers may have standard serrations such as the pliers just described, or they may have a clamp-type jaw. The clamp-type jaws are generally wide and smooth and are used primarily when working with sheet metal.

Wrench pliers have an advantage over other types of pliers in that you can clamp them on an object and they will stay. This will leave your hands free for other work.

A craftsman uses this tool a number of ways. It may be used as a clamp, speed wrench, portable vise, and for many other uses where a locking, plier-type jaw may be used. These pliers can be adjusted to various jaw openings by turning the knurled, adjusting screw at the end of the handle (fig. 1-44). Wrench pliers can be clamped and locked in position by pulling the lever toward the handle.

CAUTION

Wrench pliers should be used with care, since the teeth in the jaws tend to damage the object on which they are clamped. They should not be used on nuts, bolts, tube fittings, or other objects that must be reused.

WATER-PUMP PLIERS

Water-pump pliers were originally designed for tightening or removing water-pump packing nuts. They were excellent for this job because they have a jaw adjustable to seven different positions. Water-pump pliers (fig. 1-45) are easily identified by their size, jaw teeth, and adjustable slip joint. The inner surface of the jaws consists of a series of coarse teeth formed by deep

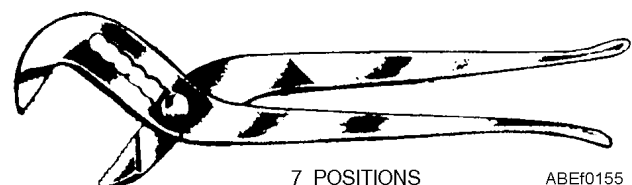

Figure 1-45.—Water-pump pliers.

grooves, a surface adapted to grasping cylindrical objects.

GROOVE-JOINT PLIERS

Groove-joint pliers (fig. 1-46) are another version of water-pump pliers and are easily identified by the extra-long handles, which make them a very powerful gripping tool. They are shaped approximately the same as the pliers just described, but the jaw opening adjustment is effected differently. Groove-joint pliers have grooves on one jaw and lands on the other. The adjustment is effected by changing the position of the grooves and lands. The groove-joint pliers are less likely to slip from the adjustment setting when gripping an object. The groove-joint pliers will only be used where it is impossible to use a more adapted wrench or holding device. Many nuts and bolts and surrounding parts have been damaged by improper use of groove-joint pliers.

DIAGONAL PLIERS

Diagonal cutting pliers (fig. 1-42) are used for cutting small, light material, such as wire and cotter pins in areas that are inaccessible to the larger cutting tools. Also, since they are designed for cutting only, larger objects can be cut than with the slip-joint pliers.

Because the cutting edges are diagonally offset approximately 15 degrees, diagonal pliers are adapted to cutting small objects flush with a surface. The inner jaw surface is a diagonal straight cutting edge. Diagonal pliers should never be used to hold objects, because they exert a greater shearing force than other types of pliers of a similar size. The sizes of the diagonal cutting pliers are designated by the overall length of the pliers.

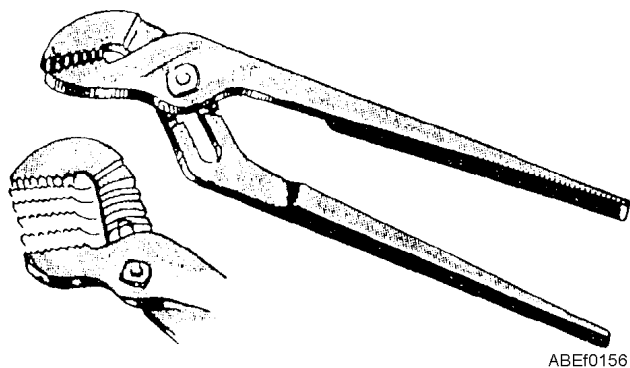

Figure 1-46.—Groove-joint pliers.

SIDE-CUTTING PLIERS

Side-cutting pliers (sidecutters) are principally used for holding, bending, and cutting thin materials or small gauge wire. Sidecutters vary in size and are designated by their overall length. The jaws are hollowed out on one side just forward of the pivot point of the pliers. Opposite the hollowed out portion of the jaws are the cutting edges (fig. 1-42).

When holding or bending light metal surfaces, the jaw tips are used to grasp the object. When holding wire, grasp it as near one end as possible because the jaws will mar the wire. To cut small-diameter wire, the side-cutting edge of the jaws near the pivot is used. Never use sidecutters to grasp large objects, tighten nuts, or bend heavy gauge metal, since such operations will spring the jaws.

Sidecutters are often called electrician or lineman pliers. They are used extensively for stripping insulation from wire and for twisting wire when making a splice.

DUCKBILL PLIERS

Duckbill pliers (fig. 1-47, view A) have long wide jaws and slender handles. Duckbills are used in confined areas where the fingers cannot be used. The jaw faces of the pliers are scored to aid in holding an item securely. Duckbills are ideal for twisting the safety wire used in securing nuts, bolts, and screws.

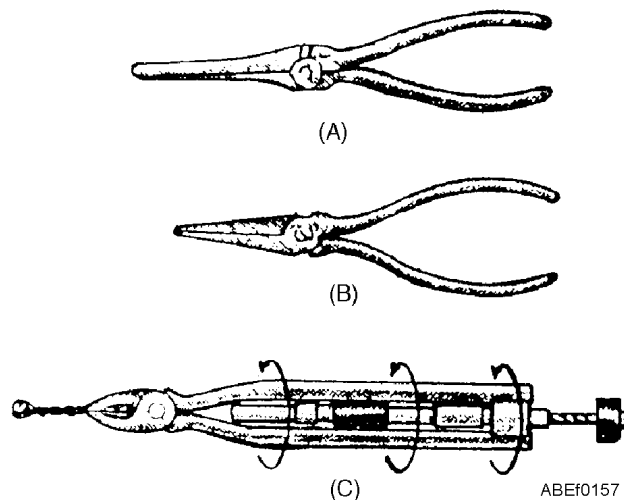

Figure 1-47.—Pliers; (A) duckbill, (B) needle-nose, and (C) wire twister.

NEEDLE-NOSE PLIERS

Needle-nose pliers (fig. 1-47, view B) are used in the same manner as duckbill pliers. However, there is a difference in the design of the jaws. Needle-nose jaws are tapered to a point, which makes them adapted to installing and removing small cotter pins. They have serrations at the nose end and a side cutter near the throat. Needle-nose pliers may be used to hold small items steady, to cut and bend safety wire, or to do numerous other jobs that are too intricate or too difficult to be done by hand alone.

NOTE

Duckbill and needle-nose pliers are especially delicate. Care should be exercised when using these pliers to prevent springing, breaking, or chipping the jaws. Once these pliers are damaged, they are practically useless.

WIRE-TWISTER PLIERS

Wire-twister pliers (safety wire pliers) (fig. 1-47, view C) are three-way pliers: they hold, twist, and cut. They are designed to reduce the time used in twisting safety wire on nuts and bolts. To operate, grasp the wire between the two diagonal jaws, and the thumb will bring the locking sleeve into place. A pull on the knob twirls the twister, making uniform twists in the wire. The spiral rod may be pushed back into the twister without unlocking it, and another pull on the knob will give a tighter twist to the wire. A squeeze on the handle unlocks the twister, and the wire can be cut to the desired length with the side cutter. The spiral of the twister should be lubricated occasionally.

MAINTENANCE OF PLIERS

Nearly all sidecutting pliers and diagonals are designed so that the cutting edges can be reground. Some older models of pliers will not close if material is ground from the cutting edges. When grinding the cutting edges, never take any more material from the jaws than is necessary to remove the nicks. Grind the same amount of stock from both jaws.

NOTE

When jaws on pliers do not open enough to permit grinding, remove the pin that attaches the two halves of the pliers, so that the jaws can be separated.

The serrations on the jaws of pliers must be sharp. When they become dull, the pliers should be held in a

vice and the serrations recut by using a small three-corner file.

Pliers should be coated with light oil when they are not in use. They should be stored in a toolbox in such a manner that the jaws cannot be injured by striking hard objects. Keep the pin or bolt at the hinge just tight enough to hold the two parts of the pliers in contact, and always keep the pivot pin lubricated with a few drops of light oil.

REVIEW QUESTIONS

- Q14. Identify the different types of pliers.
- Q15. What are wrench pliers used for?
- Q16. What are side-cutting pliers used for?
- Q17. What is used to sharpen the serrations on the jaws of pliers?

STRIKING TOOLS

LEARNING OBJECTIVES: Identify the different types of striking tools. Describe the uses of different types of striking tools. Describe the proper care of striking tools. List the safety precautions that apply to striking tools.

Hammers, mallets, and sledges are used to apply a striking force. The tool you select (fig. 1-48) will depend upon the intended application.

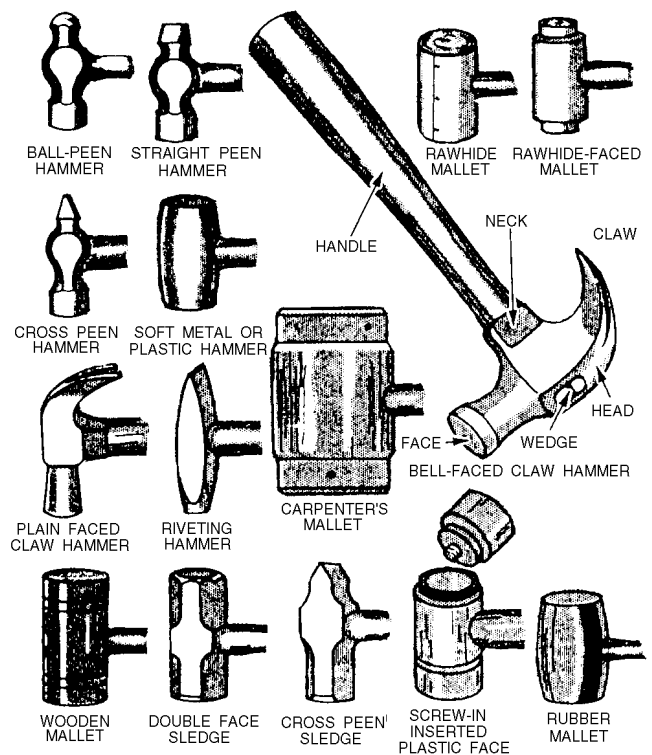

Figure 1-48.—Hammers, mallets, and sledges.

HAMMERS

A toolkit for nearly every rating in the Navy would not be complete without at least one hammer. In most cases, two or three are included, since they are designated according to weight (without the handle) and style or shape. The shape will vary according to the intended work.

Machinists' Hammers

Machinists' hammers are mostly used by people who work with metal or around machinery. These hammers are distinguished from carpenter hammers by a variable-shaped peen, rather than a claw, at the opposite end of the face (fig. 1-48). The ball-peen hammer is probably most familiar to you.

The ball-peen hammer, as its name implies, has a ball that is smaller in diameter than the face. It is therefore useful for striking areas that are too small for the face to enter.

Ball-peen hammers are made in different weights, usually 4, 6, 8, and 12 ounces and 1, 1 1/2, and 2 pounds. For most work a 1 1/2 pound and a 12-ounce hammer will suffice. However, a 4- or 6-inch hammer will often be used for light work such as tapping a punch to cut gaskets out of sheet gasket material.

Machinists' hammers may be further divided into hard-face and soft-face classifications. The hard-faced hammer is made of forged tool steel, while the soft-faced hammers have a head made of brass, lead, or a tightly rolled strip of rawhide. Plastic-faced hammers or solid plastic hammers with a lead core for added weight are becoming increasingly popular.

Soft-faced hammers (fig. 1-48) should be used when there is danger of damaging the surface of the work, as when pounding on a machined surface. Most soft-faced hammers have heads that can be replaced as the need arises. Lead-faced hammers, for instance, quickly become battered and must be replaced, but have the advantage of striking a solid, heavy nonrebounding blow that is useful for such jobs as driving shafts into or out of tight holes. If a soft-faced hammer is not available, the surface to be hammered may be protected by covering it with a piece of soft brass, copper, or hard wood.

Using Hammers

Simple as the hammer is, there is a right and a wrong way of using it. (See fig. 1-49.) The most

common fault is holding the handle too close to the head. This is known as choking the hammer, and reduces the force of the blow. It also makes it harder to hold the head in an upright position. Except for light blows, hold the handle close to the end to increase leverage and produce a more effective blow. Hold the handle with the fingers underneath and the thumb along side or on top of the handle. The thumb should rest on the handle and never overlap the fingers. Try to hit the object with the full force of the hammer. Hold the hammer at such an angle that the face of the hammer and the surface of the object being hit will be parallel. This distributes the force of the blow over the full face and prevents damage to both the surface being struck and the face of the hammer.

MALLETS AND SLEDGES

The mallet is a short-handled tool used to drive wooden-handled chisels, gouges, and wooden pins, or to form or shape sheet metal where hard-faced hammers would mar or damage the finished work. Mallet heads are made from a soft material, usually wood, rawhide, or rubber. For example, a rubber-faced mallet is used for knocking out dents in an automobile. It is cylindrically shaped with two flat driving faces that are reinforced with iron bands. (See fig. 1-48.) Never use a mallet to drive nails, screws, or any other object that can damage the face of the mallet.

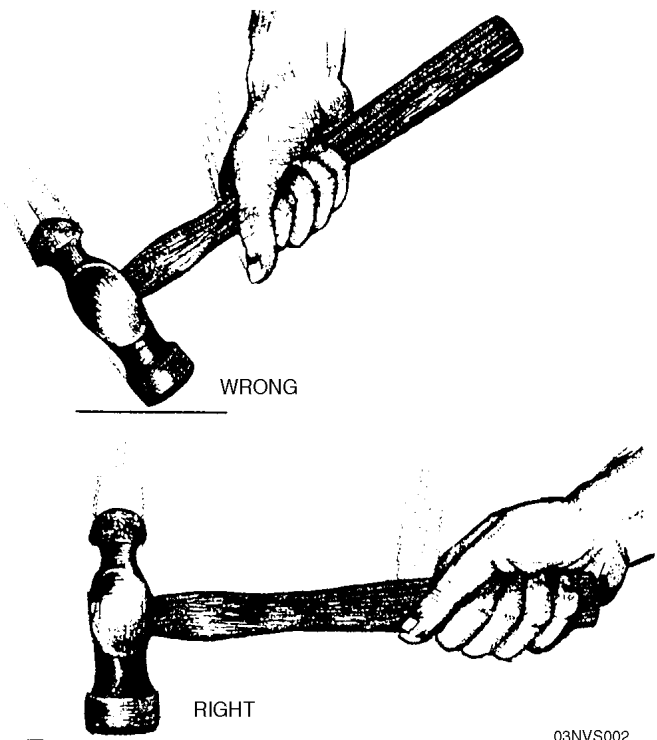

Figure 1-49.—Striking a surface.

03NVS002

The sledge is a steel-headed, heavy-duty driving tool that can be used for a number of purposes. Short-handled sledges are used to drive driftpins, and large nails, and to strike cold chisels and small hand-held rock drills. Long-handled sledges are used to break rock and concrete, to drive spikes or stakes, and to strike rock drills and chisels.

The head of a sledge is generally made of a high-carbon steel and may weigh from 2 to 16 pounds. The shape of the head will vary according to the job for which the sledge is designed.

MAINTENANCE OF STRIKING TOOLS

Hammers, sledges, or mallets should be cleaned and repaired if necessary before they are stored. Before using them, make sure the faces are free from oil or other material that would cause the tool to glance off nails, spikes, or stakes. The heads should be dressed to remove any battered edges.

Never leave a wooden or rawhide mallet in the sun, as it will dry out and may cause the head to crack. A light film of oil should be left on the mallet to maintain a little moisture in the head.

The hammer handle should always be tight in the head. If it is loose, the head may fly off and cause an injury.

SAFETY PRECAUTIONS

Hammers are dangerous tools when used carelessly and without consideration. Practice will help you learn to use a hammer properly.

Some important things to remember when using a hammer or mallet follow:

- Do not use a hammer handle for bumping parts in assembly, and never use it as a pry bar. Such abuses will cause the handle to split, and a split handle can produce bad cuts or pinches. When a handle splits or cracks, do not try to repair it by binding with string, wire, or tape. Replace it.
- Make sure the handle fits tightly on the head.
- Do not strike a hardened steel surface with a steel hammer. Small pieces of steel may break off and injure someone in the eye or damage the work. However, it is permissible to strike a punch or chisel directly with a ball-peen hammer, because the steel in the heads of

punches and chisels is slightly softer than that of the hammerhead.

REVIEW QUESTIONS

- Q18. Identify the different types of striking tools.
- Q19. Describe the uses of different types of striking tools.
- Q20. Describe the proper care of striking tools.
- Q21. List the safety precautions that apply to striking tools.

PUNCHES

LEARNING OBJECTIVES: Identify the different types of punches. Describe the uses of different types of punches.

A hand punch is a tool that is held in the hand and struck on one end with a hammer. There are many kinds of punches designed to do a variety of jobs. Figure 1-50 shows several types of punches. Most punches are made of tool steel. The part held in the hand is usually octagonal in shape, or it may be knurled. This prevents the tool from slipping around in the hand. The other end is shaped to do a particular job.

When you use a punch, there are two things to remember:

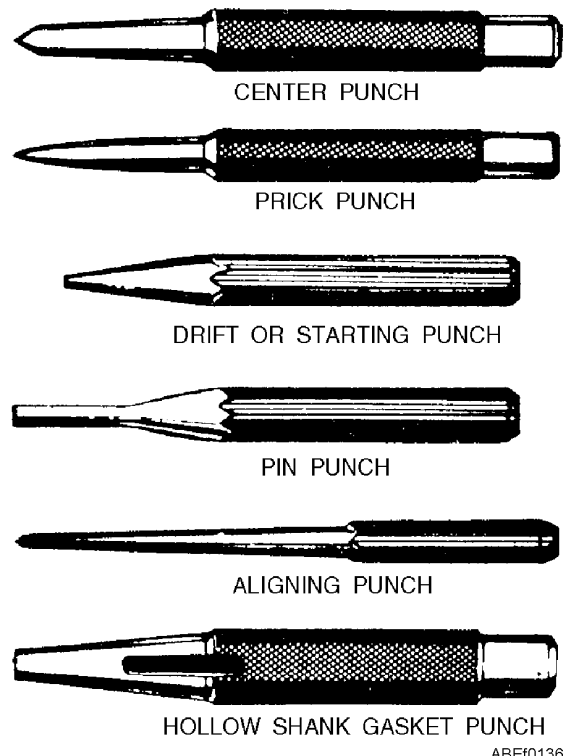

Figure 1-50.—Punches.

ABE0136

1. When you hit the punch, you do not want it to slip sideways over your work.
2. You do not want the hammer to slip off the punch and strike your fingers. You can eliminate both of these troubles by holding the punch at right angles to the work and striking the punch squarely with your hammer.

The center punch, as the name implies, is used for marking the center of a hole to be drilled. If you try to drill a hole without first punching the center, the drill will "wander" or "walk away" from the desired center.

Another use of the center punch is to make corresponding marks on two pieces of an assembly to permit reassembling in the original positions. Before taking a mechanism apart, make a pair of center punchmarks in one or more places to help in reassembly. To do this, select places, staggered as shown in figure 1-51, where matching pieces are joined. First, clean the places selected. Then, scribe a line across the joint, and center punch the line on both sides of the joint, with single and double marks as shown to eliminate possible errors. In reassembly, refer first to the sets of punchmarks to determine the approximate position of the parts. Then line up the scribed lines to determine the exact position.

To make the intersection of two layout lines, bring the point of the prick punch to the exact point of intersection and tap the punch lightly with a hammer. If inspection shows that the exact intersection and the punchmark do not coincide, as in view A of figure 1-52, slant the punch as shown in view B and strike again with the hammer, thus enlarging the punchmark and centering it exactly. When the intersection has been correctly punched, finish off with a light blow on the punch held in an upright position. View C shows the corrected punchmark.

DRIFT punches, sometimes called "starting punches," have a long taper from the tip to the body.

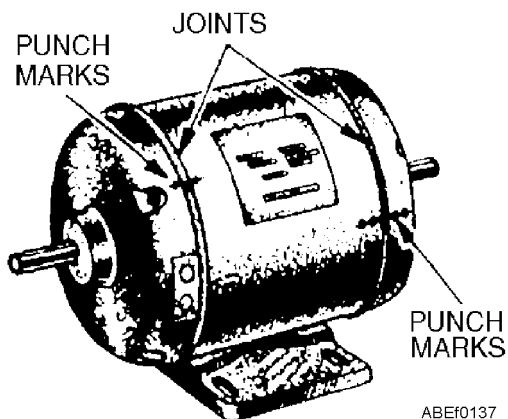

Figure 1-51.—Punch marking mating parts.

They are made that way to withstand the shock of heavy blows. They may be used for knocking out rivets after the heads have been chiseled off or for freeing pins that are "frozen" in their holes.

After a pin has been loosened or partially driven out, the drift punch may be too large to finish the job. The follow-up tool to use is the PIN PUNCH. It is designed to follow through the hole without jamming. Always use the largest drift or pin punch that will fit the hole. These punches usually come in sets of three to five assorted sizes. Both of these punches will have flat ends, never edged or rounded.

To remove a bolt or pin that is extremely tight, start with a drift punch that has an end diameter that is slightly smaller than the diameter of the object you are removing. As soon as the bolt or pin loosens, finish driving it out with a pin punch. Never use a pin punch for starting a pin, because it has a slim shank and a hard blow may cause it to bend or break.

For assembling units of a machine, an ALIGNMENT (aligning) punch is invaluable. It is usually about 1-foot long and has a long gradual taper. Its purpose is to line up holes in mating parts.

Hollow metal-cutting punches are made from hardened tool steel. They are made in various sizes and are used to cut holes in light gauge sheet metal.

Other punches have been designed for special uses. One of these is the soft-faced drift. It is made of brass or fiber and is used for such jobs as removing shafts, bearings, and wrist pins from engines. It is generally heavy enough to resist damage to itself, but soft enough not to injure the finished surface on the part that is being driven.

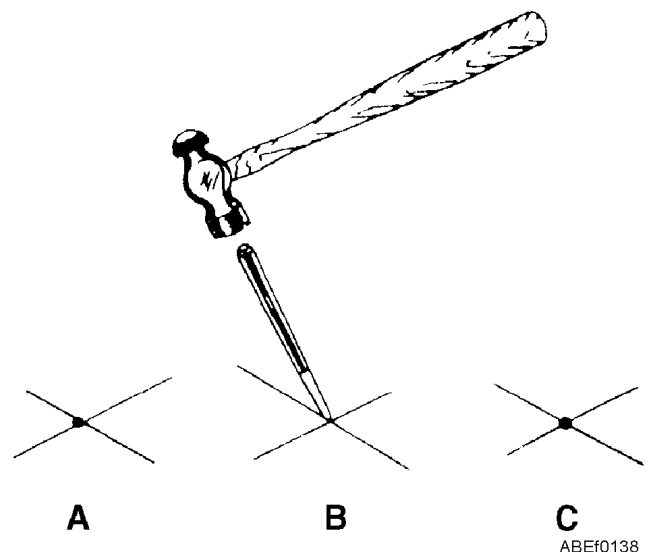

Figure 1-52.—Marking the intersection of lines with a prick punch.

You may have to make gaskets of rubber, cork, leather, or composition materials. For cutting holes in gasket materials, a hollow shank GASKET PUNCH may be used (fig. 1-50). Gasket punches come in sets of various sizes to accommodate standard bolts and studs. The cutting end is tapered to a sharp edge to produce a clean uniform hole. To use the gasket punch, place the gasket material to be cut on a piece of hard wood or lead so that the cutting edge of the punch will not be damaged. Then strike the punch with a hammer, driving it through the gasket where holes are required.

REVIEW QUESTIONS

- Q22. Identify the different types of punches.
 Q23. What is a center punch used for?
 Q24. What is a prick punch used for?

TAPS AND DIES

LEARNING OBJECTIVES: Identify the different types of taps and dies. Describe the uses of different types of taps and dies.

Taps and dies are used to cut threads in metal, plastics, or hard rubber. The taps are used for cutting internal threads, and the dies are used to cut external threads. There are many different types of taps. However, the most common are the taper, plug, bottoming, and pipe taps (fig. 1-53).

The taper (starting) hand tap has a chamfer length of 8 to 10 threads. These taps are used when starting a tapping operation and when tapping through holes.

Plug hand taps have a chamfer length of 3 to 5 threads and are designed for use after the taper tap.

Bottoming hand taps are used for threading the bottom of a blind hole. They have a very short chamfer length of only 1 to 1 1/2 threads for this purpose. This tap is always used after the plug tap has been used. Both the taper and plug taps should precede the use of the bottoming hand tap.

Pipe taps are used for pipefitting and other places where extremely tight fits are necessary. The tap diameter, from end to end of the threaded portion, increases at the rate of 3/4 inch per foot. All the threads on this tap do the cutting, as compared to the straight taps, where only the nonchamfered portion does the cutting.

Dies are made in several different shapes and are of the solid or adjustable type. The square pipe die (fig.

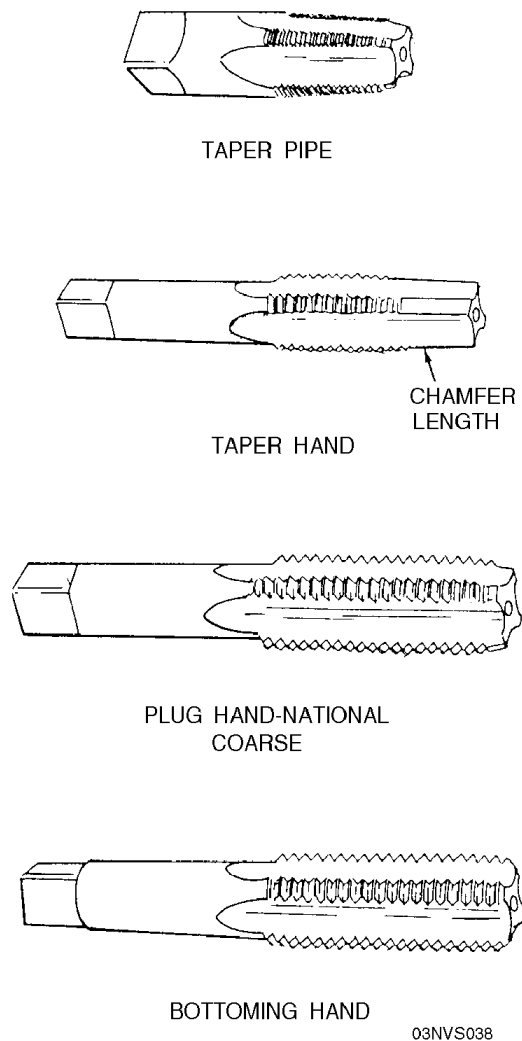

Figure 1-53.—Types of common taps.

1-54) will cut American Standard Pipe thread only. It comes in a variety of sizes for cutting threads on pipe with diameters of 1/8 inch to 2 inches.

A rethreading die (fig. 1-54) is used principally for dressing over bruised or rusty threads on screws or bolts. It is available in a variety of sizes for rethreading American Standard Coarse and Fine threads. These dies are usually hexagon in shape and can be turned

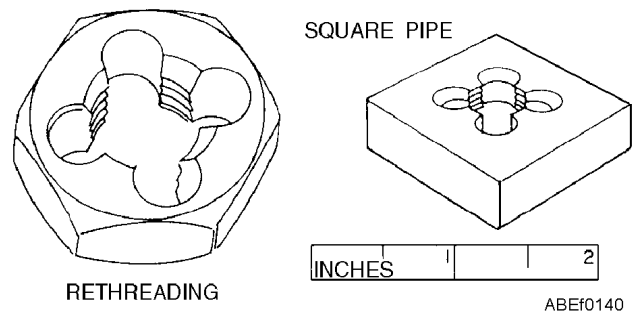
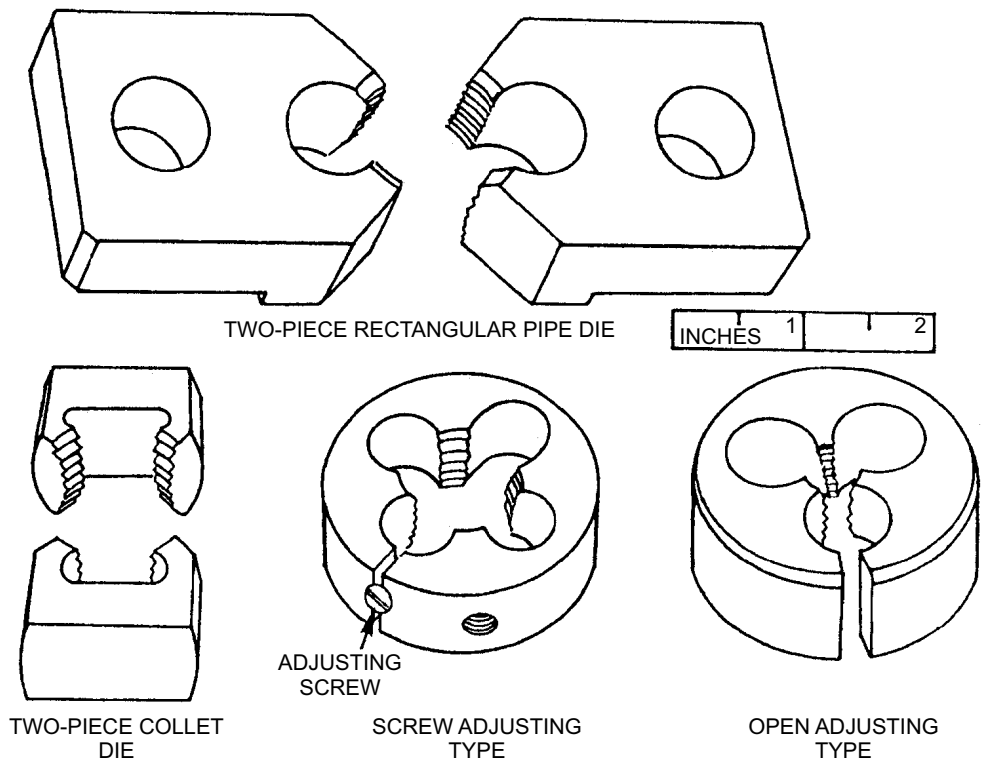

Figure 1-54.—Types of solid dies.



ABEF0141

Figure 1-55.—Types of adjustable dies.

with a socket, box, open-end, or any wrench that will fit. Rethreading dies are available in sets of 6, 10, 14, and 28 assorted sizes in a case.

Round split adjustable dies (fig. 1-55) are called "Burton" dies and can be used in either hand diestocks or machine holders. The adjustment in the screw adjusting type is made by a fine-pitch screw, which

forces the sides of the die apart or allows them to spring together. The adjustment in the open adjusting type is made by means of three screws in the holder, one for expanding and two for compressing the dies.

Two piece collet dies (fig. 1-55) are used with a collet cap (fig. 1-56) and collet guide. The die halves are placed in the cap slot and are held in place by the

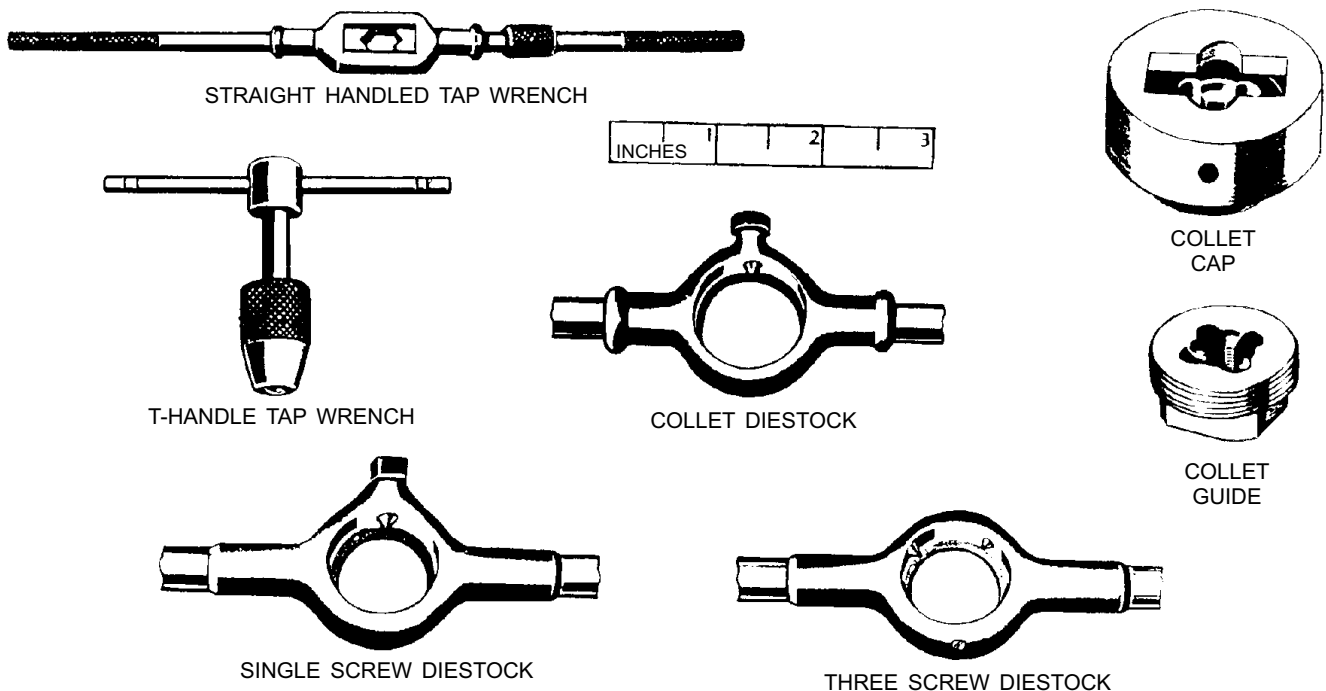

ABEF0142

Figure 1-56.—Diestocks, diecollet, and tap wrenches.

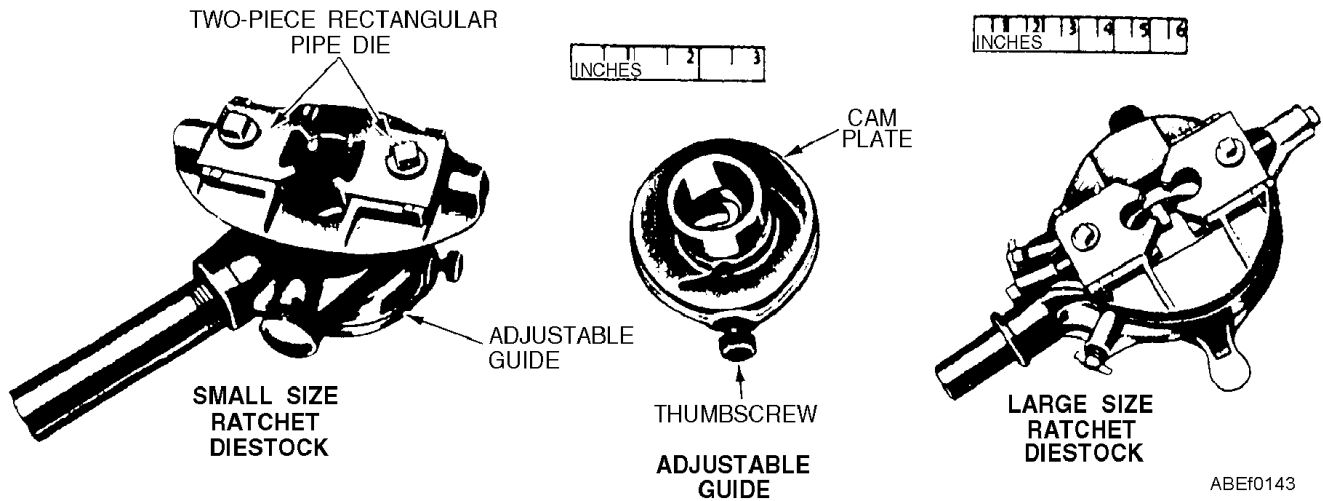

Figure 1-57.—Adjustable die guide and ratchet diestocks.

guide, which screws into the underside of the cap. The die is adjusted by setscrews at both ends of the interval slot. This type of adjustable die is issued in various sizes to cover the cutting ranges of American Standard Coarse and Fine and special-form threads. Diestocks to hold the dies come in three different sizes.

Two-piece rectangular pipe dies (fig. 1-55) are available to cut American Standard Pipe threads. They are held in ordinary or ratchet-type diestocks (fig. 1-57).

Threading sets are available in many different combinations of taps and dies, together with diestocks, tap wrenches, guides, and necessary screwdrivers and wrenches to loosen and tighten adjusting screws and bolts. Figure 1-58 illustrates typical threading sets for pipe, bolts, and screws.

Never attempt to sharpen taps or dies. Sharpening of taps and dies involves several highly precise cutting processes that involve the thread characteristics and chamfer. These sharpening procedures must be done by experienced personnel to maintain the accuracy and the cutting effectiveness of taps and dies.

Keep taps and dies clean and well oiled when not in use. Store them so that they do not contact each other or other tools. For long periods of storage, coat taps and dies with a rust-preventive compound, place in individual or standard threading set boxes, and store in a dry place.

REVIEW QUESTIONS

Q25. Identify the different types of taps.

- Q26. What are taper taps used for?
- Q27. Identify the different types of dies.
- Q28. What are two-piece rectangular pipe dies used for?

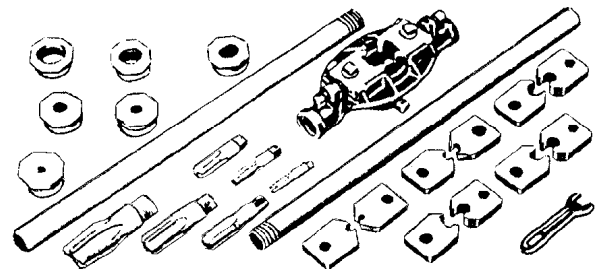

PIPE THREADING SET WITH RECTANGULAR ADJUSTABLE DIES, DIESTOCK, WRENCH, GUIDES AND TAPS

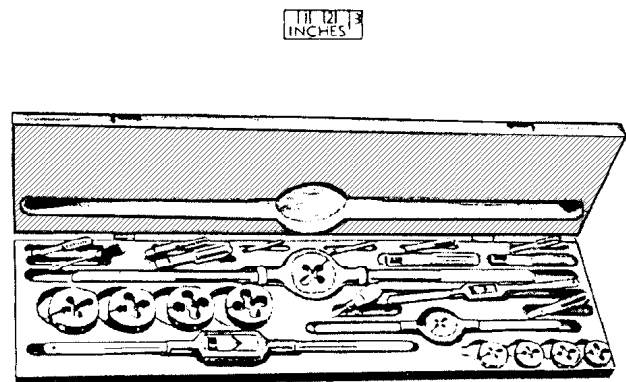

BOLT AND SCREW THREADING SET WITH ROUND ADJUSTABLE SPLIT DIES, DIESTOCKS, TAPS, TAP WRENCHES, AND SCREWDRIVERS

Figure 1-58.—Tap and die thread sets.

POWER TOOLS

LEARNING OBJECTIVES: Identify the different types of power tools. Describe the uses of different types of power tools. List the safety precautions that apply to power tools. List the safety precautions that apply to extension cords.

Power tools have become so commonplace in the Navy that all ratings now use them in the performance of maintenance at one time or another.

The following paragraphs are devoted to the identification, general-operating practices, and care of these tools.

DRILLS

The portable electric drill (fig. 1-59) is probably the most frequently used power tool in the Navy. Although it is especially designed for drilling holes, by adding various accessories you can adapt it for different jobs. Sanding, sawing, buffing, polishing, screw driving, wire brushing, and paint mixing are examples of possible uses.

Portable electric drills commonly used in the Navy have capacities for drilling holes in steel from 1/16 inch up to 1 inch in diameter. The sizes of portable electric drills are classified by the maximum size straight shank drill it will hold. That is, a 1/4-inch electric drill will hold a straight shank drill bit up to and including 1/4 inch in diameter.

The revolutions per minute (rpm) and power the drill will deliver are most important when choosing a drill for a job. You will find that the speed of the drill motor decreases with an increase in size, primarily because the larger units are designed to turn larger cutting tools or to drill in heavy materials, and both of these factors require slower speed.

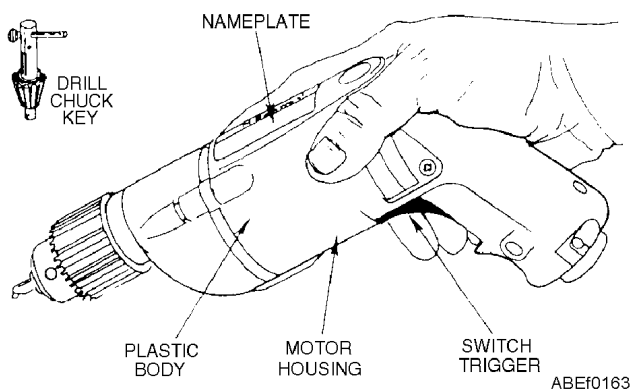

Figure 1-59.—1/4-inch portable electric drill.

If you are going to do heavy work, such as drilling in masonry or steel, then you would probably need to use a drill with a 3/8- or 1/2-inch capacity. If most of your drilling will be forming holes in wood or small holes in sheet metal, then a 1/4-inch drill will probably be adequate.

The chuck is the clamping device into which the drill bit is inserted. Nearly all electric drills are equipped with a three-jaw chuck. Some drills have a hand-type chuck that you tighten or loosen by hand, but most of the drills used in the Navy have gear-type, three-jaw chucks, which are tightened and loosened by a chuck key, shown in figure 1-60. Do not apply further pressure with pliers or wrenches after you hand tighten the chuck with the chuck key.

Always remove the key IMMEDIATELY after you use it. Otherwise the key will fly loose when the drill motor is started and may cause serious injury to you or one of your shipmates. The chuck key is generally taped on the cord of the drill; but if it is not, make sure you put it in a safe place where it will not get lost.

All portable electric drills used in the Navy have controls similar to the ones shown on the 1/4-inch drill in figure 1-59. This drill has a momentary contact trigger switch located in the handle. The switch is squeezed to start the electric drill and released to stop it.

The trigger latch is a button in the bottom of the drill handle. It is pushed in while the switch trigger is held down to lock the trigger switch in the ON position. The trigger latch is released by squeezing and then releasing the switch trigger.

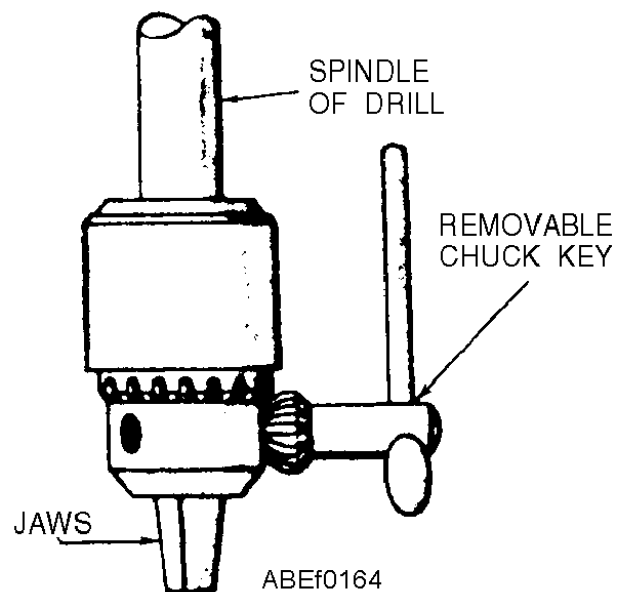

Figure 1-60.—Three-jaw chuck and chuck key.

DISK SANDER

Electric disk sanders (fig. 1-61) are especially useful on work where a large amount of material is to be removed quickly, such as in scaling surfaces in preparation for painting. This machine, however, must not be used where a mirror-smooth finish is required.

The disk should be moved smoothly and lightly over the surface. Never allow the disk to stay in one place too long, because it will cut into the metal and leave a large depression.

PORTABLE GRINDERS

Portable grinders are power tools that are used for rough grinding and finishing of metallic surfaces. They are made in several sizes; however, the one used most in the Navy uses a grinding wheel with a maximum diameter of 6 inches. See figure 1-62.

The abrasive wheels are easily replaceable so that different grain size and grades of abrasives can be used for the various types of surfaces to be ground and the different degrees of finish desired.

A flexible shaft attachment is available for most portable grinders. This shaft is attached by removing the grinding wheel, then attaching the shaft to the grinding wheel drive spindle. The grinding wheel can then be attached to the end of the flexible shaft. This attachment is invaluable for grinding surfaces in hard-to-reach places.

ELECTRIC IMPACT WRENCH

The electric impact wrench (fig. 1-63) is a portable, hand-type reversible wrench. The one shown has a 1/2-inch-square impact-driving anvil, over which 1/2-inch-square drive sockets can be fitted. Wrenches also can be obtained that have impact driving anvils ranging from 3/8 inch to 1 inch. The driving anvils are

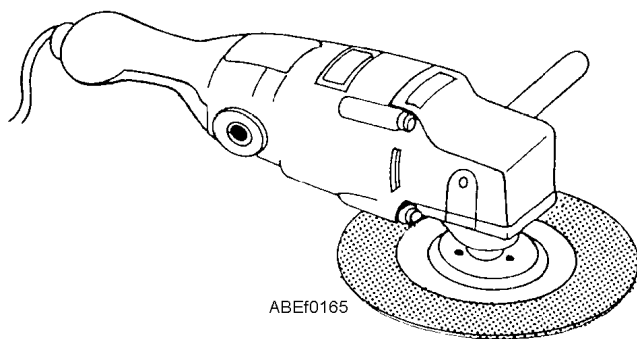

Figure 1-61.—Portable electric sander.

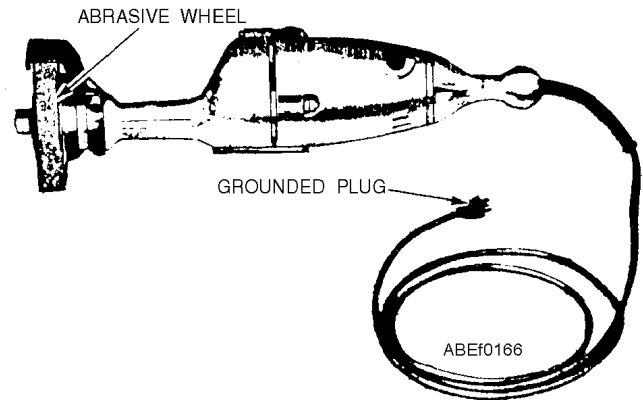

Figure 1-62.—Portable grinder.

not interchangeable, however, from one wrench to another.

The electric wrench with its accompanying equipment is primarily intended for applying and removing nuts, bolts, and screws. It may also be used to drill and tap metal, wood, plastics, and so on, and to drive and remove socket-head, Phillips-head, or slotted-head wood, machine, or self-tapping screws.

Before you use an electric impact wrench, depress the on-and-off trigger switch and allow the electric wrench to operate a few seconds, noting carefully the direction of rotation. Release the trigger switch to stop the wrench. Turn the reversing ring, located at the rear of the tool; it should move easily in one direction (which is determined by the current direction of rotation). Depress the on-and-off trigger again to start the electric wrench. The direction of rotation should now be reversed. Continue to operate for a few seconds in each direction to be sure that the wrench and its reversible features are functioning correctly. When you

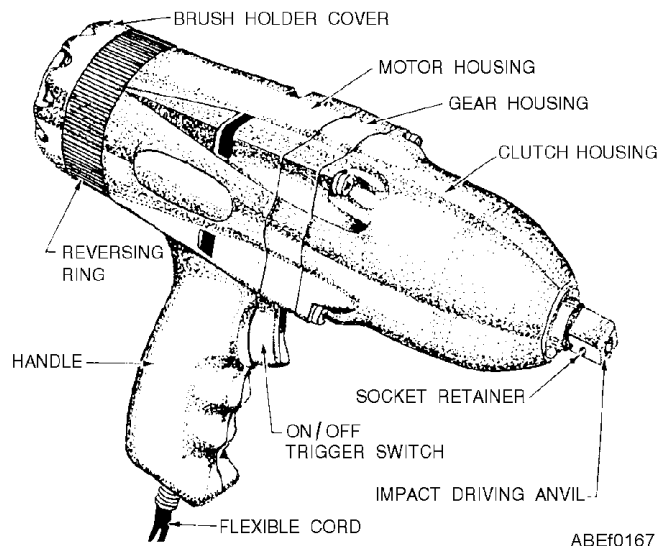

Figure 1-63.—Reversible electric impact wrench.

are sure the wrench operates properly, place the suitable equipment on the impact-driving anvil and go ahead with the job at hand.

SAFETY PRECAUTIONS FOR USE WITH PORTABLE ELECTRICAL TOOLS

When portable electric tools are used, you should use the following procedures:

- Before portable electrical tools are used they must be inspected and approved for shipboard use by the ship's electrical safety officer.
- Prior to the use of any portable electric tools, you should make sure the tools have a current ship's inspection mark. Additionally, visually examine the attached cable with the plug and any extension cords for cracks, breaks, or exposed conductors and damaged plugs. When any defects are noted, the tools should be turned in to the ship's electrical shop for repair before use. Before plugging in any tool, be sure the tool is turned off.
- Personnel using portable electric tools are required to wear safety glasses/goggles.
- Portable electric tools producing hazardous noise levels in excess of the limits set forth in OPNAVINST 5100.19 (Series) are required to be conspicuously labeled. Personnel using tools designated as producing hazardous noise levels are required to wear proper ear protection, as issued by the medical department.
- Only explosion-proof (class I, group D, or better) portable electric tools should be used where flammable vapors, gases, liquids, or exposed explosives are present.
- Hand-held portable electric tools authorized for use on board ship shall be equipped with ON/OFF switches, which must be manually held in the closed ON position to maintain operation.
- Rubber gloves must be worn when you are using portable electric tools under hazardous conditions; for example, wet decks, bilge areas, working over the side, in boats, and so forth.
- Leather glove shells should be worn over rubber gloves when the work being done, such as sheet metal work, could damage the rubber gloves.

SAFETY PRECAUTIONS FOR USE WITH EXTENSION CORDS

You should use the following procedures when using extension cords:

- Only three-wire extension cords that have three-pronged plugs and three-slot receptacles should be used.
- Because a metal hull ship is a hazardous location, personnel who must use portable electric devices connected to extension cords should take the time to plug the device into the extension cord before the extension cord is inserted into a live bulkhead receptacle. Likewise, the extension cord should be unplugged from the bulkhead receptacle before the device is unplugged from the extension cord.
- Electrical cords shall be cared for as follows:
 - Cords should not be allowed to come in contact with sharp objects. They should not be allowed to kink nor should they be left where they might be damaged by vehicle/foot traffic. When it is necessary to run electrical leads through doors and hatches, the cords must be protected to guard against accidental closing of the doors/hatches.
 - Cords must not come in contact with oil, grease, hot surfaces, or chemicals.
 - Damaged cords must be replaced. They are not to be patched with tape.
 - Cords must be stored in a clean, dry place where they can be loosely coiled.
 - Cords extending through walkways should be elevated so they do not become a tripping hazard or interfere with safe passage.
 - Extension cords should be no longer than 25 feet (except repair locker and CV flight deck cords, which are 100 feet long). No more than two such cords should be connected together for the operation of portable equipment.

REVIEW QUESTIONS

- Q29. Identify the different types of power tools.*
- Q30. What are electric drills used for?*

- Q31. List the safety precautions that apply to power tools.
- Q32. List the safety precautions that apply to extension cords.

PORTABLE PNEUMATIC POWER TOOLS

LEARNING OBJECTIVES: Identify different types of portable pneumatic power tools. Describe the uses of different types of portable pneumatic power tools. List the safety precautions that apply to portable pneumatic power tools.

Portable pneumatic power tools are tools that look much the same as electric power tools but use the energy of compressed air instead of electricity. Because of the limited outlets for compressed air aboard ship and shore stations, the use of pneumatic power tools is not as widespread as electric tools. Portable pneumatic tools are used most around a shop where compressed air outlets are readily accessible.

PNEUMATIC CHIPPING HAMMER

The pneumatic chipping hammer (fig. 1-64) consists basically of a steel piston that is reciprocated (moved backward and forward alternately) in a steel barrel by compressed air. On its forward stroke the piston strikes the end of the chisel, which is a sliding fit in a nozzle pressed into the barrel. The rearward stroke is cushioned by compressed air to prevent any metal-to-metal contact. Reciprocation of the piston is automatically controlled by a valve located on the rear end of the barrel. Located on the rear end of the barrel is a grip handle, containing a throttle valve.

The pneumatic hammer may be used for beveling; caulking or beading operations; and for drilling in brick, concrete, and other masonry.

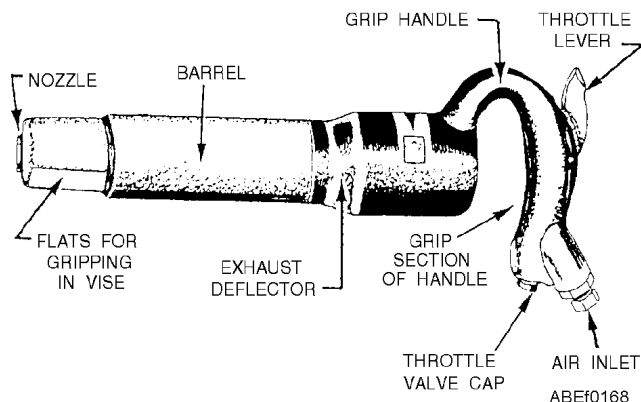

Figure 1-64.—Pneumatic chipping hammer.

Chipping hammers should not be operated without safety goggles, and all other persons in the immediate vicinity of the work should wear goggles.

While working, never point the chipping hammer in such a direction that other personnel might be struck by an accidentally ejected tool. When chipping alloy steel or doing other heavy work, it is helpful to dip the tool in engine lubricating oil about every 6 inches of the cut and make sure the cutting edge of the tool is sharp and clean. This will allow faster and easier cutting and will reduce the possibility of the tool breaking.

When nearing the end of a cut, ease off on the throttle lever to reduce the intensity of the blows. This will avoid any possibility of the chip or tool flying.

If for any reason you have to lay the chipping hammer down, always remove the attachment tool from the nozzle. Should the chipping hammer be accidentally started when the tool is free, the blow of the piston will drive the tool out of the nozzle with great force and may damage equipment or injure personnel.

ROTARY AND NEEDLE IMPACT SCALERS

Rotary and needle scalers (figs. 1-65 and 1-66) are used to remove rust, scale, and old paint from metallic and masonry surfaces. You must be especially careful when using these tools since they will "chew" up anything in their path. Avoid getting the power line or any part of your body in their way.

The rotary scaling and chipping tool, sometimes called a "jitterbug," has a bundle of cutters or chippers for scaling or chipping (fig. 1-65). In use, the tool is pushed along the surface to be scaled, and the rotating chippers do the work. Replacement bundles of cutters are available when the old ones are worn.

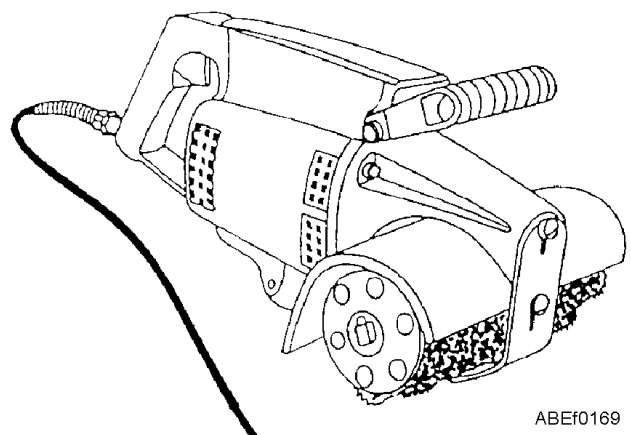

Figure 1-65.—Rotary impact scaler.

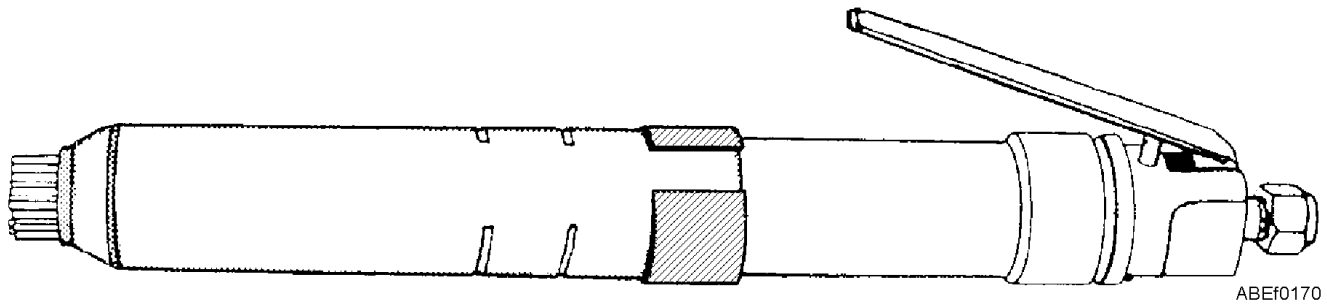

Figure 1-66.—Needle impact scaler.

BE SURE YOU ARE NOT DAYDREAMING when you use the rotary scaler.

Needle scalers accomplish their task with an assembly of individual needles impacting on a surface hundreds of times a minute. The advantage of using individual needles is that irregular surfaces can be cleaned readily. See figure 1-66.

PORTABLE PNEUMATIC IMPACT WRENCH

The portable pneumatic impact wrench (fig. 1-67) is designed for installing or removing nuts and bolts. The wrench comes in different sizes and is classified by the size of the square anvil on the drive end. The anvil is equipped with a socket lock, which provides positive locking of the socket wrenches or attachments.

Nearly all pneumatic wrenches operate most efficiently on an air pressure range of 80 to 100 psi. Lower pressure causes a decrease in the driving speeds, while higher pressure causes the wrench to overspeed with subsequent abnormal wear of the motor impact mechanisms.

Before operating the pneumatic impact wrench, make sure the socket or other attachment you are using is properly secured to the anvil. It is always a good idea to operate the wrench free of load in both forward and reverse directions to see that it operates properly. Check the installation of the air hose to make sure it is in accordance with the manufacturer's recommendation.

SAFETY PRECAUTIONS FOR USE WITH PNEUMATIC TOOLS—GENERAL

When using pneumatic tools, you should use the following procedures:

- You should wear and use necessary personnel protective devices. Pneumatic tools shall not be connected to, or driven by, air pressure in excess

of that for which the tools are designed. The wearing of appropriate eye protection equipment is mandatory for Navy personnel when operating pneumatic tools.

- You should be authorized and trained to operate pneumatic tools.
- Pneumatic tools should be laid down in such a manner that no harm can be done if the switch is accidentally tripped. No idle tools should be left in a standing position.
- Pneumatic tools should be kept in good operating condition. They should be thoroughly inspected at regular intervals with particular attention given to the ON-OFF control valve trigger guard (if installed), hose connections, guide clips on hammers, and the chucks of reamers and drills.
- Pneumatic tools and air lines may be fitted with quick-disconnect fittings. These should incorporate an automatic excess-flow shutoff valve. This valve automatically shuts off the air

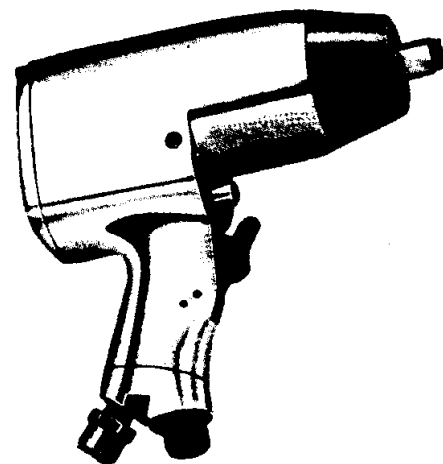

ABDf0171
Figure 1-67.—Pneumatic impact wrench.

at the air lines before changing grinding wheels, needles, chisels, or other cutting or drilling bits.

- The air hose must be suitable to withstand the pressure required for the tool. A leaking or defective hose should be removed from service. The hose should not be laid over ladders, steps, scaffolds, or walkways in such a manner as to create a tripping hazard. Where the hose is run through doorways, the hose should be protected against damage by the doors' edges. The air hose should generally be elevated over walkways or working surfaces in a manner to permit clear passage and to prevent damage to it.
- All portable pneumatic grinders must be equipped with a safety lock-off device. A safety lock-off device is any operating control that requires positive action by the operator before the tools can be turned on. The lock-off device must automatically and positively lock the throttle in the OFF position when the throttle is released. Two consecutive operations by the same hand are required, first to disengage the lock-off device and then to turn on the throttle. The lock-off device should be integral with the tool. It should not adversely affect the safety or operating characteristics of the tools, and it should not be easily removable. Devices, such as a "dead-man control," that do not automatically and positively lock the throttle in the OFF position when the throttle is released are not safety lock-off devices.

For detailed information on safety precautions, see *Navy Occupational Safety and Health (NAVOSH) Program Manual for Forces Afloat, OPNAVINST 5100.19 (latest series)*.

SAFETY PRECAUTIONS FOR USE WITH PNEUMATIC TOOLS—SPECIFIC

In operating or maintaining air-driven tools, take the following precautionary measures to protect yourself and others from the damaging effects of compressed air:

- Inspect the air hose for cracks or other defects; replace the hose if found defective.

WARNING

Before opening the control valve, see that nearby personnel are not in the path of the airflow. Never point the hose at another person.

- Open the control valve momentarily before connecting an air hose to the compressed air outlet. Then, make sure the hose is clear of water and other foreign material by connecting it to the outlet and again opening the valve momentarily.
- Stop the flow of air to a pneumatic tool by closing the control valve at the compressed air outlet before connecting, disconnecting, adjusting, or repairing a pneumatic tool.

REVIEW QUESTIONS

- Q33. Identify different types of portable pneumatic power tools.
- Q34. What are rotary and needle sanders used for?
- Q35. List the safety precautions that apply to portable pneumatic power tools.

SCREW AND TAP EXTRACTORS

LEARNING OBJECTIVE: State the purpose of screw and tap extractors.

Screw extractors are used to remove broken screws without damaging the surrounding material or the threaded hole. Tap extractors are used to remove broken taps (fig. 1-68, view A).

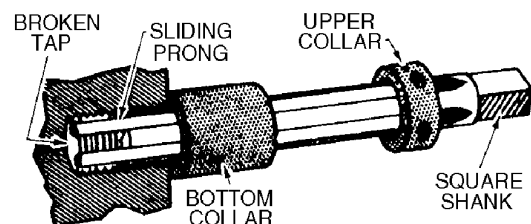

A. STRAIGHT TAP EXTRACTOR

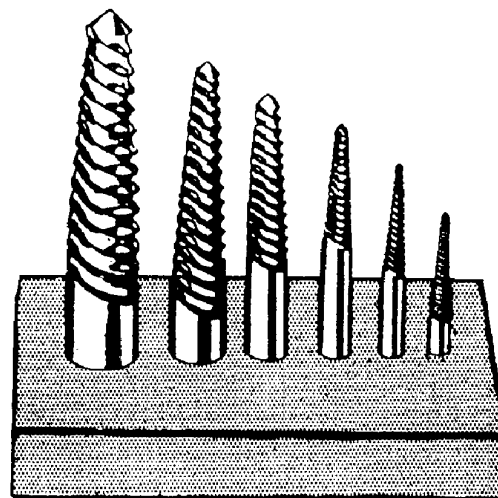

B. SPIRAL SCREW EXTRACTORS

ABEF0145

Figure 1-68.—Screw and tap extractors.

Screw extractors (view B) are straight, with spiraling flutes at one end. These extractors are available in sizes to remove broken screws having 1/4- to 1/2-inch outside diameters (ODs). Spiral tapered extractors are sized to remove screws and bolts from 3/16 inch to 2 1/8 inches OD.

Most sets of extractors include twist drills and a drill guide. Tap extractors are similar to the screw extractors and are sized to remove taps ranging from 3/16 inch to 2 1/8 inches OD.

To remove a broken screw or tap with a spiral extractor, first drill a hole of proper size in the screw or tap. The size hole required for each screw extractor is stamped on it. The extractor is then inserted in the hole, and turned counterclockwise to remove the defective component.

REVIEW QUESTIONS

Q36. State the purpose of screw and tap extractors.

PIPE AND TUBING CUTTERS AND FLARING TOOLS

LEARNING OBJECTIVES: State the purpose of pipe cutters, tube cutters, and flaring tools.

Pipe cutters (fig. 1-69) are used to cut pipe made of steel, brass, copper, wrought iron, or lead. Tube cutters

(fig. 1-69) are used to cut tubing made of iron, steel, brass, copper, or aluminum. The essential difference between pipe and tubing is that tubing has considerably thinner walls. Flaring tools (fig. 1-70) are used to make flares in the ends of tubing.

Two sizes of hand pipe cutters are generally used in the Navy. The No. 1 pipe cutter has a cutting capacity of 1/8 inch to 2 inches, and the No. 2 pipe cutter has a cutting capacity of 2 to 4 inches. The pipe cutter (fig. 1-69) has a special alloy-steel cutting wheel and two pressure rollers, which are adjusted and tightened by turning the handle.

Most TUBE CUTTERS closely resemble pipe cutters, except that they are of lighter construction. A hand screw feed tubing cutter of 1/8-inch to 1 1/4-inch capacity (fig. 1-69) has two rollers with cutouts located off center so that cracked flares may be held in them and cut off without waste of tubing. It also has a retractable cutter blade, which is adjusted by turning a knob. The other tube cutter shown is designed to cut tubing up to and including 1 inch OD. Rotation of the triangular portion of the tube cutter within the tubing will eliminate any burrs.

FLARING TOOLS (fig. 1-70) are used to flare soft copper, brass, or aluminum. The single flaring tool consists of a split die block, which has holes for 3/16-, 1/4-, 5/16-, 3/8-, 7/16-, and 1/2-inch OD tubing; a clamp to lock the tube in the die block; and a yoke,

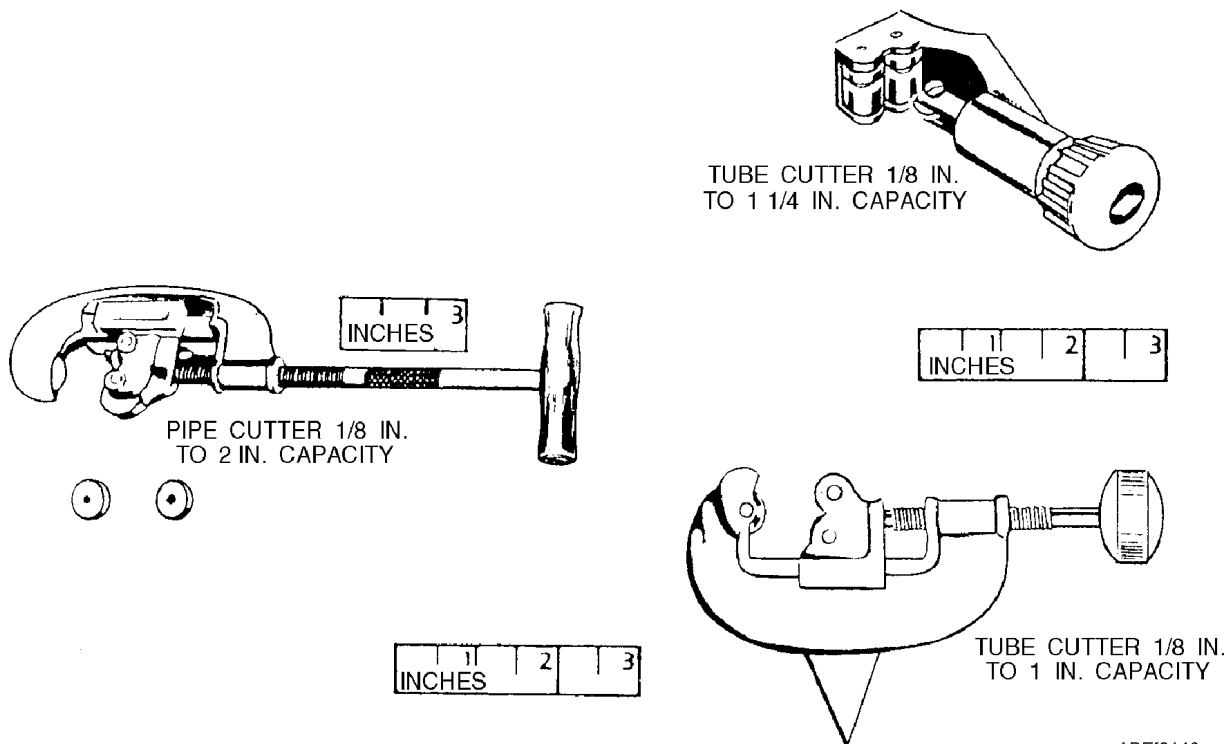

ABEF0146

Figure 1-69.—Pipe and tubing cutters.

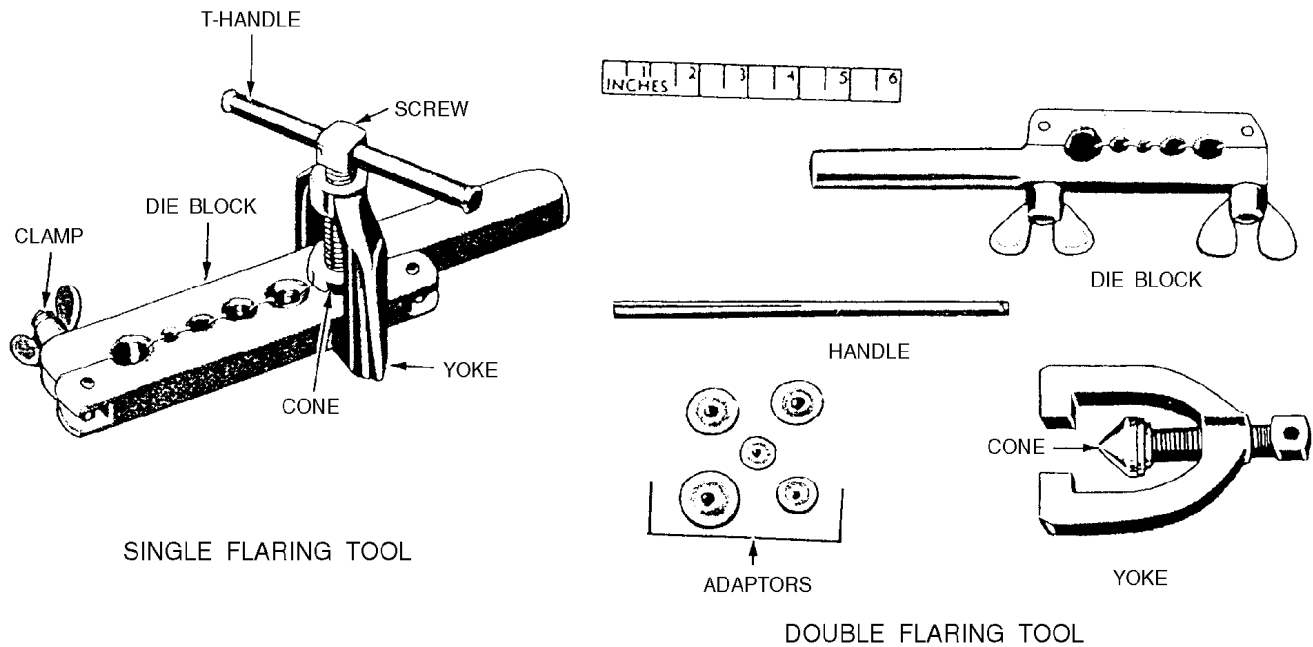

ABEf0147

Figure 1-70.—Flaring tools.

which slips over the die block and has a compressor screw and a cone that forms a 45-degree flare or a bell shape on the end of the tube. The screw has a T-handle. A double flaring tool has the additional feature of adapters, which turn in the edge of the tube before a regular 45-degree double flare is made. It consists of a die block with holes for 3/16-, 1/4-, 5/16-, 3/8-, and 1/2-inch tubing; a yoke with a screw and a flaring cone; plus five adapters for different size tubing, all carried in a metal case.

REVIEW QUESTIONS

- Q37. What are pipe cutters used for?
 Q38. What are tube cutters used for?
 Q39. What are flaring tools used for?

SCREWDRIVERS

LEARNING OBJECTIVES: Identify the different types of screwdrivers. List the safety precautions that apply to screwdrivers.

A screwdriver is one of the most basic of handtools. It is also the most frequently abused of all hand tools. It is designed for one function only—to drive and to remove screws. A screwdriver should not be used as a pry bar, a scraper, a chisel, or a punch.

STANDARD

There are three main parts to a standard screwdriver. The portion you grip is called the handle, the steel portion extending from the handle is the shank, and the end that fits into the screw is called the blade (fig. 1-71).

The steel shank is designed to withstand considerable twisting force in proportion to its size, and the tip of the blade is hardened to keep it from wearing.

Standard screwdrivers are classified by size, according to the combined length of the shank and blade. The most common sizes range in length from 2 1/2 to 12 inches. There are many screwdrivers smaller and some larger for special purposes. The diameter of the shank, and the width and thickness of the blade are generally proportionate to the length, but again there are special screwdrivers with long thin shanks, short thick shanks, and extra wide or extra narrow blades.

When using a screwdriver, you should select the proper size so that the blade fits the screw slot properly. This prevents burring the slot and reduces the force required to hold the driver in the slot. Keep the shank perpendicular to the screw head (fig. 1-72).

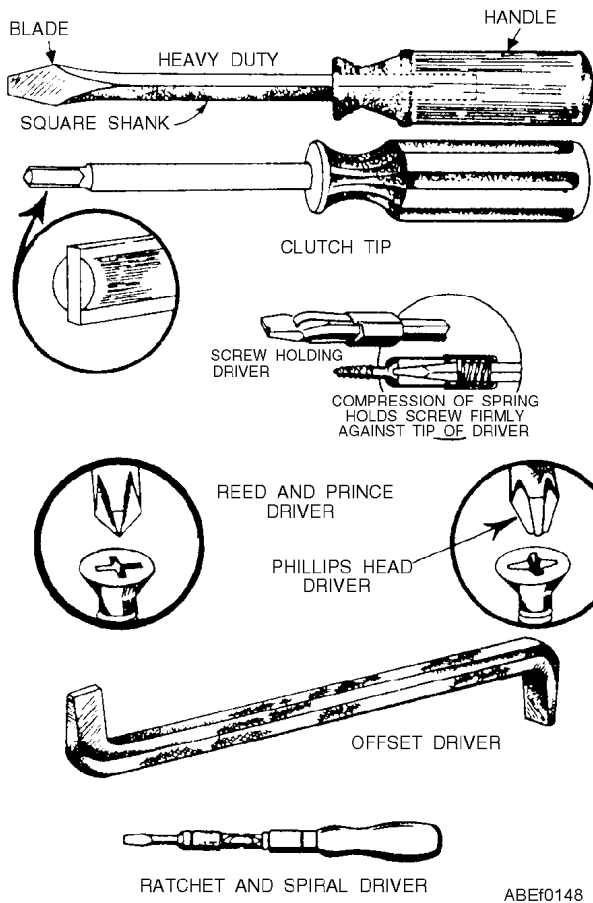

Figure 1-71.—Types of screwdrivers.

RECESSED

Recessed screws are now available in various shapes. They have a cavity formed in the head and require a specially shaped screwdriver. The clutch tip (fig. 1-71) is one shape, but the more common include the Phillips, Reed and Prince, and newer Torq-Set types (fig. 1-73). The most common type of screw found is the Phillips head. This requires a Phillips-type screwdriver (fig. 1-71).

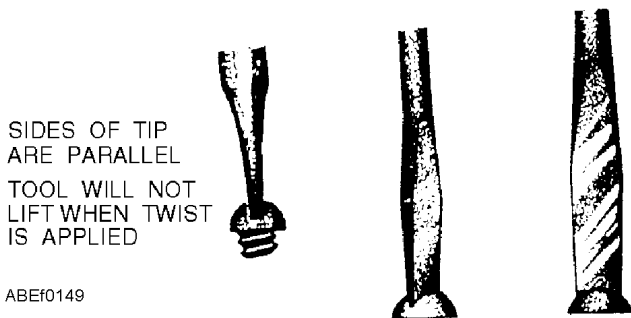

Figure 1-72.—Positioning screwdrivers.

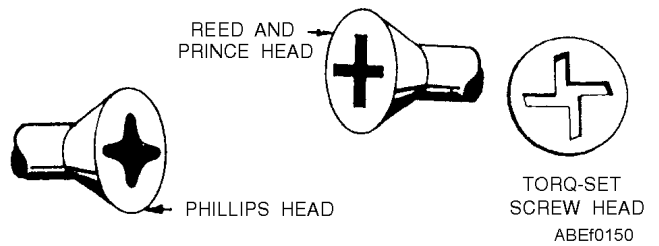

Figure 1-73.—Comparison of Phillips, Reed and Prince, and Torq-Set screwheads.

Phillips Screwdriver

The head of a Phillips-type screw has a four-way slot into which the screwdriver fits. This prevents the screwdriver from slipping. Three standard-sized Phillips screwdrivers handle a wide range of screw sizes. Their ability to hold helps to prevent damaging the slots or the work surrounding the screw. It is a poor practice to try to use a standard screwdriver on a Phillips screw, because both the tool and screw slot will be damaged.

Reed and Prince Screwdriver

Reed and Prince screwdrivers are not interchangeable with Phillips screwdrivers. Therefore, always use a Reed and Prince screwdriver with Reed and Prince screws, and a Phillips screwdriver with Phillips screws, or a ruined tool or ruined screwhead will result.

To distinguish between these similar screwdrivers, refer to figure 1-74.

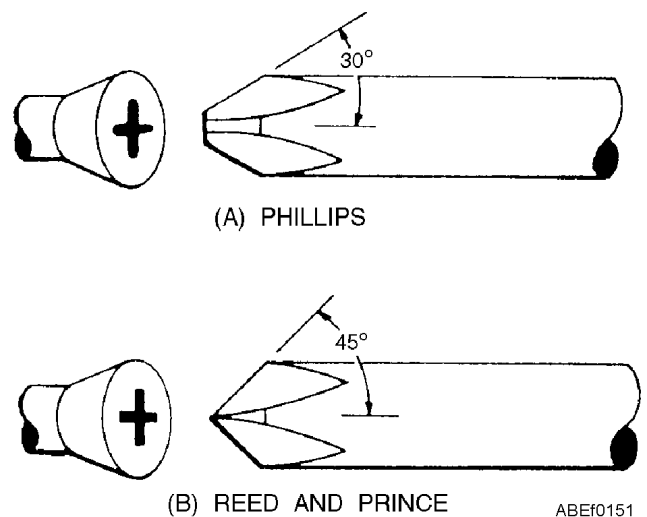

Figure 1-74.—Matching cross-slot screws and screwdrivers.

The Phillips screwdriver has about 30-degree flukes and a blunt end, while the Reed and Prince has 45-degree flukes and a sharper, pointed end. The Phillips screw has beveled walls between the slots; the Reed and Prince, straight, pointed walls. In addition, the Phillips screw slot is not as deep as the Reed and Prince slot.

Additional ways to identify the right screwdriver are as follows:

1. If the screwdriver tends to stand up unassisted when the point is put in the head of a vertical screw, it is probably the proper one.
2. The outline of the end of a Reed and Prince screwdriver is approximately a right angle, as seen in figure 1-74.
3. In general, Reed and Prince screws are used for airframe structural applications, while Phillips screws are found most often in component assemblies.

Torq-Set Screws

Torq-Set machine screws (offset cross-slot drive) have recently begun to appear in new equipment. The main advantage of the newer type is that more torque can be applied to its head while tightening or loosening than to any other screw of comparable size and material without damaging the head of the screw.

Torq-Set machine screws are similar in appearance to the more familiar Phillips machine screws.

Since a Phillips driver could easily damage a Torq-Set screwhead, making it difficult if not impossible to remove the screw even if the proper tool is later used, maintenance personnel should be alert to the differences (fig. 1-73) and make sure the proper tool is used.

OFFSET SCREWDRIVERS

An offset screwdriver (fig. 1-71) may be used where there is not sufficient vertical space for a standard or recessed screwdriver. Offset screwdrivers are constructed with one blade forged in line and another blade forged at right angles to the shank handle. Both blades are bent 90 degrees to the shank handle. By alternating ends, most screws can be seated or loosened even when the swinging space is very restricted. Offset screwdrivers are made for both standard and recessed-head screws.

RATCHET SCREWDRIVER

For fast, easy work, the ratchet screwdriver (fig. 1-71), is extremely convenient, as it can be used one-handed and does not require the bit to be lifted out of the slot after each turn. It may be fitted with either a standard-type bit or a special bit for recessed heads. The ratchet screwdriver is most commonly used by the woodworker for driving screws in soft wood.

SAFETY

Screwdrivers, like any other hand tool, are dangerous when not used properly. Therefore, the following safety precautions should always be followed:

- Never use a screwdriver to check an electrical circuit.
- Never try to turn a screwdriver with a pair of pliers.
- Do not hold work in your hand while using a screwdriver—if the point slips, it can cause a bad cut. Hold the work in a vise, with a clamp, or on a solid surface. If that is impossible, you will always be safe if you follow this rule: **NEVER GET ANY PART OF YOUR BODY IN FRONT OF THE SCREWDRIVER BLADE TIP.** That is a good safety rule for any sharp or pointed tool.

REVIEW QUESTIONS

- Q40. Identify the different types of screwdrivers.*
- Q41. List the safety precautions that apply to screwdrivers.*

MECHANICAL FINGERS

LEARNING OBJECTIVES: Describe the use of mechanical fingers.

Small articles that have fallen into places where they cannot be reached by hand may be retrieved with mechanical fingers. Mechanical fingers, shown in figure 1-75, have a tube containing flat springs, which extend from the end of the tube to form clawlike fingers, much like the screw holder. The springs are attached to a rod that extends from the outer end of the tube. A plate is attached to the end of the tube, and a similar plate to be pressed by the thumb is attached to the end of the rod. A coil spring placed around the rod

between the two plates holds them apart and retracts the fingers into the tube.

With the bottom plate grasped between the fingers and enough thumb pressure applied to the top plate to compress the spring, the tool fingers extend from the tube in a grasping position. When the thumb pressure is released, the tool fingers retract into the tube as far as the object they hold will allow. Thus, enough pressure is applied on the object to hold it securely. Some mechanical fingers have a flexible end on the tube to permit their use in close quarters or around obstructions (fig. 1-75).

NOTE

The fingers are made of thin sheet metal or spring wire and can be easily damaged by overloading.

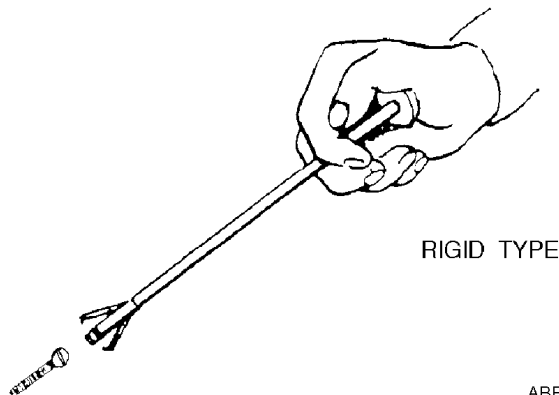
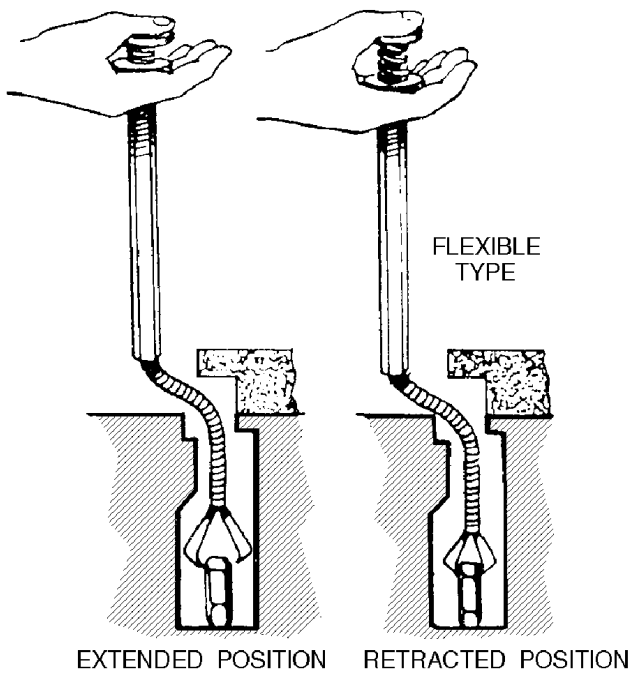

ABEF0158

Figure 1-75.—Mechanical fingers.

REVIEW QUESTIONS

Q42. What are mechanical fingers used for?

FLASHLIGHT

LEARNING OBJECTIVES: Identify the type of flashlight that belongs in every toolbox.

Each toolbox should have a standard Navy vaporproof two-cell flashlight. The flashlight is used constantly during all phases of maintenance. Installed in both ends of the flashlight are rubber seals, which keep out all vapors. The flashlight should be inspected periodically for these seals, the spare bulb, and colored filters, which are contained in the cap.

NOTE

Do not throw away the filters; they will be necessary during night operations.

REVIEW QUESTION

Q43. Identify the type of flashlight that belongs in every toolbox.

INSPECTION MIRROR

LEARNING OBJECTIVES: Describe the use of inspection mirrors.

Several types of inspection mirrors are available for use in maintenance. The mirror is issued in a variety of sizes and may be round or rectangular. The mirror is connected to the end of a rod and may be fixed or adjustable (fig. 1-76).

The inspection mirror aids in making detailed inspections where the human eye cannot directly see the inspection area. By angling the mirror, and with the aid of a flashlight, it is possible to inspect most required areas. One model of inspection mirror features a built-in light to aid in viewing those dark places where use of a flashlight is not convenient.

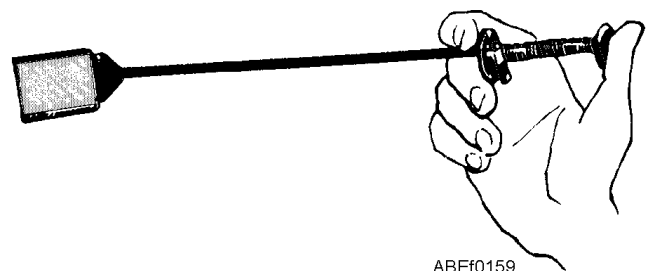

Figure 1-76.—Adjustable inspection mirror.

SUMMARY

This chapter introduced you to the specific purposes, correct uses, and proper care of some of the common hand tools and power tools that you will use as an ABE. You should be able to select, maintain, and safely use tools required for maintenance of catapults

and arresting gear. Blueprints, electrical prints, piping prints, and aperture cards were discussed. By thoroughly understanding this chapter, you, as an ABE, will be able to perform your daily duties more efficiently and safely.

CHAPTER 2

MEASURING TOOLS AND TECHNIQUES

When performing maintenance and repair tasks on catapults and arresting gear equipment, you must take accurate measurements during inspection, to determine the amount of wear or service life remaining on a particular item or to make sure replacement parts used to repair equipment meet established specifications. The accuracy of these measurements, often affecting the performance and failure rates of the concerned equipment, depends on the measuring tool you use and your ability to use it correctly.

COMMON MEASURING TOOLS

LEARNING OBJECTIVES: Identify the different types of measuring tools. Describe the uses of different types of measuring tools. Describe the proper care of measuring tools.

You will use many different types of measuring tools in the daily performance of your duties. Where exact measurements are required, use a micrometer caliper (mike). If you use the micrometer caliper properly, it will allow you to measure within one ten-thousandth (0.0001) of an inch accuracy. On the other hand, where accuracy is not extremely critical, a common straightedge rule or tape rule will suffice for most measurements.

RULES AND TAPES

Figure 2-1 illustrates some of the commonly used straightedge and tape rules. Of all measuring tools, the

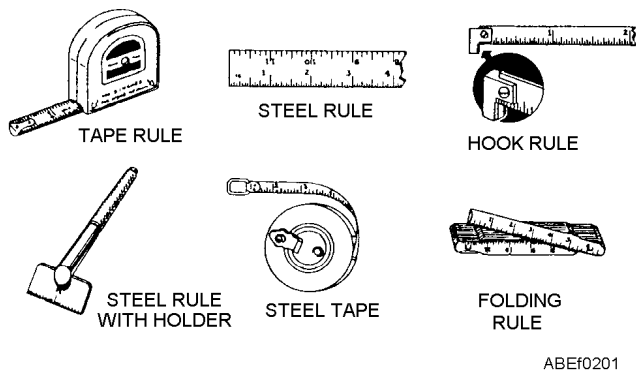

Figure 2-1.—Some common types of rules.

simplest and most common is the steel or wooden straightedge rule. This rule is usually 6 or 12 inches long, although other lengths are available. Steel rules may be flexible or nonflexible, but the thinner the rule is, the easier it is to measure accurately with it, because the division marks are closer to the work to be measured.

Generally, a rule has four sets of graduated division marks, one on each edge of each side of the rule. The longest lines represent the inch marks. On one edge, each inch is divided into 8 equal spaces, so each space represents 1/8 inch. The other edge of this side is divided into sixteenths. The 1/4-inch and 1/2-inch marks are commonly made longer than the smaller division marks to facilitate counting, but the graduations are not normally numbered individually, as they are sufficiently far apart to be counted without difficulty. The opposite side of the rule is similarly divided into 32 and 64 spaces per inch, and it is common practice to number every fourth division for easier reading.

There are many variations of the common rule. Sometimes the graduations are on one side only, sometimes a set of graduations is added across one end for measuring in narrow spaces, and sometimes only the first inch is divided into 64ths, with the remaining inches divided into 32nds and 16ths.

Steel tapes are made from 6 to about 300 feet in length. The shorter lengths are frequently made with a curved cross section so that they are flexible enough to roll up, but remain rigid when extended. Long, flat tapes require support over their full length when measuring, or the natural sag will cause an error in reading.

MEASURING PROCEDURES

To take a measurement with a common rule, hold the rule with its edge on the surface of the object being measured. This will eliminate parallax and other errors that might result because of the thickness of the rule. Read the measurement at the graduation that coincides with the distance to be measured, and state it as being so

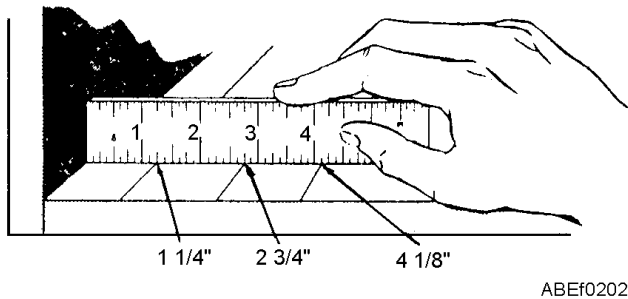

Figure 2-2.—Measuring with and reading a common rule.

many inches and fractions of an inch. (See fig. 2-2.) Always reduce fractions to their lowest terms, for example, 6/8 inch would be called 3/4 inch. A hook or eye at the end of a tape or rule is normally part of the first measured inch.

Bolts and Screws

The length of bolts and screws is best measured by holding them up against a rigid rule or tape. Hold both the rule and the bolt or screw to be measured up to your eye level, so that your line of sight will not be in error in reading the measurement. As shown in figure 2-3, the bolts or screws with countersink-type heads are measured from the top of the head to the opposite end, while those with other types of heads are measured from the bottom of the head.

Outside Pipe Diameters

To measure the outside diameter of a pipe, you should use some kind of rigid rule. A wooden rule or a steel rule is satisfactory for this purpose. As shown in figure 2-4, line up the end of the rule with one side of the pipe, using your thumb as a stop. Then, with the one end held in place with your thumb, swing the rule through an arc and take the maximum reading at the

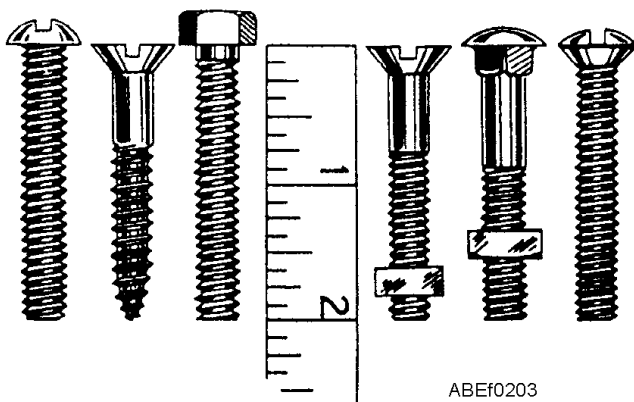

Figure 2-3.—Measuring the length of a bolt or screw.

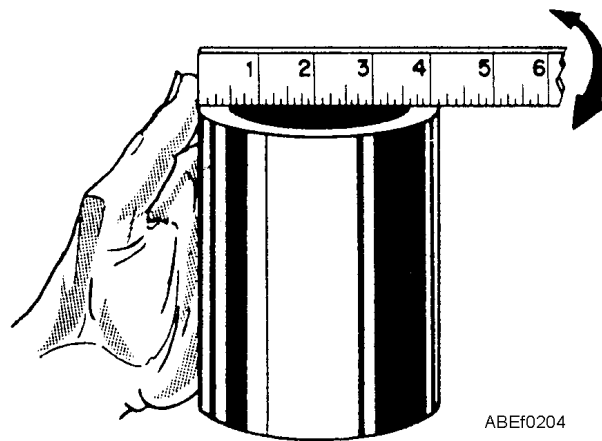

Figure 2-4.—Measuring the outside diameter of a pipe.

other side of the pipe. For most purposes, the measurement obtained by using this method is satisfactory. It is necessary that you know how to take this measurement, as the outside diameter of pipe is sometimes the only dimension given on pipe specifications.

Inside Pipe Diameters

To measure the inside diameter of a pipe with a rule, as shown in figure 2-5, hold the rule so that one corner of the rule just rests on the inside of one side of the pipe. Then, with one end thus held in place, swing the rule through an arc and read the diameter across the maximum inside distance. This method is satisfactory for an approximate inside measurement.

Pipe Circumferences

To measure the circumference of a pipe, you must use a flexible-type rule that will conform to the shape of the pipe. A fabric or steel flexible tape rule is adaptable to this job. When measuring the pipe, make sure the tape is wrapped squarely around the axis of the pipe to ensure that the measurement will not be more than the

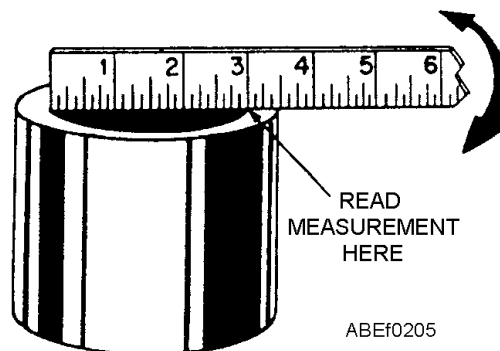

Figure 2-5.—Measuring the inside diameter of a pipe.

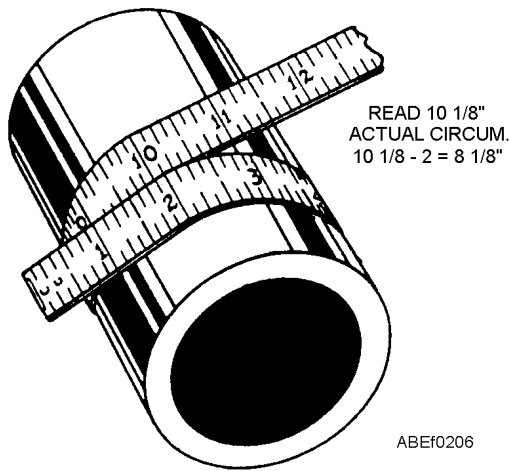

Figure 2-6.—Measuring the circumference of a pipe with a tape rule.

actual circumference of the pipe. This is extremely important when you are measuring a large diameter pipe.

Hold the rule or tape as shown in figure 2-6. Take the reading, using the 2-inch graduation, for example, as the reference point. In this case the correct reading is found by subtracting 2 inches from the actual reading. In this way the first 2 inches of the tape, serving as a handle, will enable you to hold the tape securely.

Inside Dimensions

For an inside measurement such as the inside of a box, a folding rule that incorporates a 6- or 7-inch sliding extension is one of the best measuring tools. To take the inside measurement, first unfold the folding rule to the approximate dimension. Then, extend the end of the rule and read the length that it extends, adding the length of the extension to the length on the

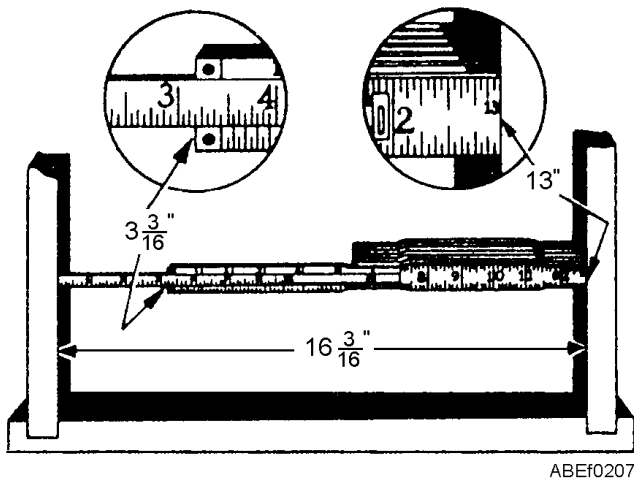

Figure 2-7.—Using a folding rule to measure an inside dimension.

main body of the rule. See figure 2-7. In this illustration the length of the main body of the rule is 13 inches, and the extension is pulled out $3 \frac{3}{16}$ inches; the total inside dimension being measured is $16 \frac{3}{16}$ inches.

Notice in the circled inset in figure 2-8 that the hook at the end of the particular rule shown is attached to the rule so that it is free to move slightly. When an outside dimension is taken by hooking the end of the rule over an edge, the hook will move to locate the end of the rule even with the surface from which the measurement is being taken. By being free to move, the hook will retract toward the end of the rule when an inside dimension is taken. To measure an inside dimension using a tape rule, extend the rule between the surfaces as shown, take a reading at the point on the scale where the rule enters the case, and add 2 inches. The 2 inches are the length of the case. The total is the inside dimension being taken.

Outside Dimensions

To measure an outside dimension using a tape rule, hook the rule over the edge of the stock. Pull the tape out until it projects far enough from the case to permit measuring the required distance. The hook at the end of the rule is designed so that it will locate the end of the rule at the surface from which the measurement is being taken. When taking a measurement of length, hold the tape parallel to the lengthwise edge. For measuring widths, the tape should be at right angles to the lengthwise edge. Read the dimension of the rule exactly at the edge of the piece being measured.

It may not always be possible to hook the end of the tape over the edge of stock being measured. In this case it may be necessary to butt the end of the tape against another surface or to hold the rule at a starting point from which a measurement is to be taken.

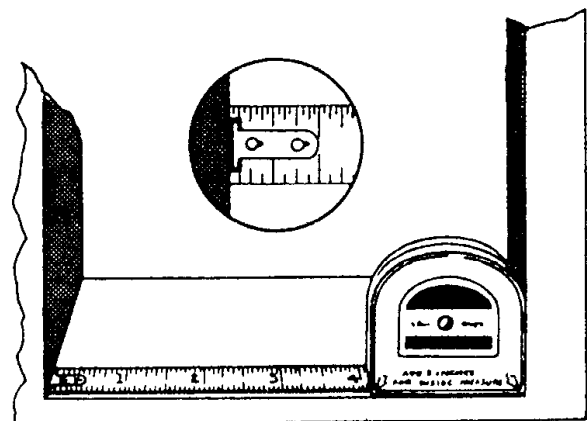

Figure 2-8.—Measuring an inside dimension with a tape rule.

Distance Measurements

Steel or fiberglass tapes are generally used for making long measurements. Secure the hook end of the tape. Hold the tape reel in the hand and allow it to unwind while walking in the direction in which the measurement is to be taken. Stretch the tape with sufficient tension to overcome sagging. At the same time make sure the tape is parallel to an edge or the surface being measured. Read the graduation on the tape by noting which line on the tape coincides with the measurement being taken.

CARE OF RULES AND TAPES

Handle rules and tapes carefully and keep metal ones lightly oiled to prevent rust. Never allow the edges of measuring devices to become nicked by striking

them with hard objects. They should preferably be kept in a wooden box when not in use.

To avoid kinking tapes, pull them straight out from their cases—do not bend them backward. With the windup type, always turn the crank clockwise—turning it backward will kink or break the tape. With the spring-wind type, guide the tape by hand. If it is allowed to snap back, it may be kinked, twisted, or otherwise damaged. Do not use the hook as a stop. Slow down as you reach the end.

SIMPLE CALIPERS

Simple calipers are used in conjunction with a scale or rule to determine the thickness or the diameter of a surface, or the distance between surfaces. The calipers you will most commonly use are shown in figure 2-9.

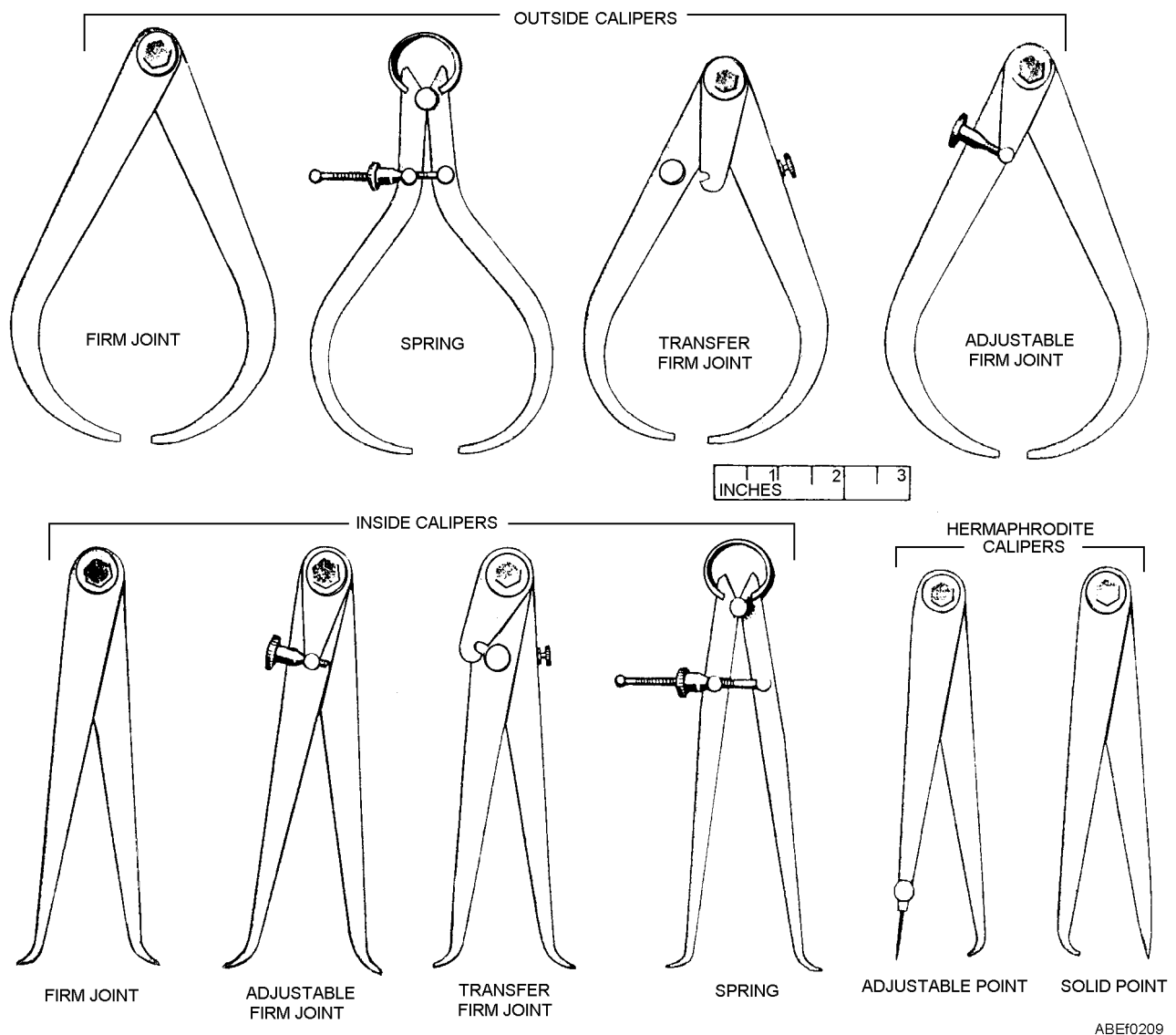

Figure 2-9.—Simple calipers—noncalibrated.

ABEF0209

Outside calipers for measuring outside diameters are bow-legged; those used for inside diameters have straight legs with the feet turned outward. Calipers are adjusted by pulling or pushing the legs to open or close them. Fine adjustment is made by tapping one leg lightly on a hard surface to close them, or by turning them upside down and tapping on the joint end to open them.

Spring-joint calipers have the legs joined by a strong spring hinge and linked together by a screw and adjusting nut. For measuring chamfered cavities (grooves) or for use over flanges, transfer calipers are available. They are equipped with a small auxiliary leaf attached to one of the legs by a screw (fig. 2-9). The measurement is made as with ordinary calipers; then the leaf is locked to the leg. The legs may then be opened or closed as needed to clear the obstruction, then brought back and locked to the leaf again, thus restoring them to the original setting.

A different type of caliper is the hermaphrodite, sometimes called odd-leg caliper. This caliper has one straight leg ending in a sharp point, sometimes removable, and one bow leg. The hermaphrodite caliper is used chiefly for locating the center of a shaft, or for locating a shoulder.

USING CALIPERS

A caliper is usually used in one of two ways. Either the caliper is set to the dimension of the work and the dimension transferred to a scale, or the caliper is set on a scale and the work machined until it checks with the

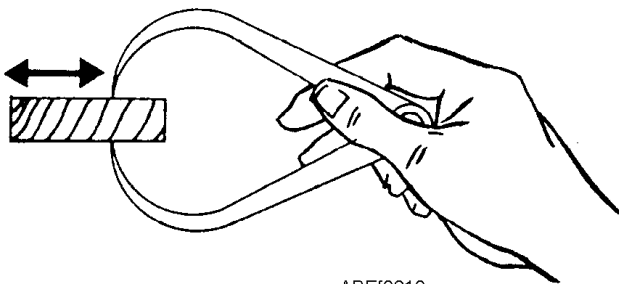
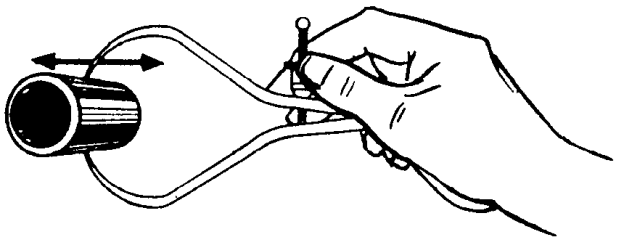

ABEf0210

Figure 2-10.—Using an outside caliper.

dimension set up on the caliper. To adjust a caliper to a scale dimension, hold one leg of the caliper firmly against one end of the scale and adjust the other leg to the desired dimension. To adjust a caliper to the work, open the legs wider than the work and then bring them down to the work.

CAUTION

Never place a caliper on work that is revolving in a machine.

Measuring the Diameter of Round Stock or the Thickness of Flat Stock

To measure the diameter of round stock or the thickness of flat stock, adjust the outside caliper so that you feel a slight drag as you pass it over the stock. (See fig. 2-10.) After the proper "feel" has been attained, measure the setting of the caliper with a rule. In reading the measurement, sight over the leg of the caliper after making sure the caliper is set squarely with the face of the rule.

Measuring the Distance Between Two Surfaces

To measure the distance between two surfaces with an inside caliper, first set the caliper to the approximate distance being measured. Hold the caliper with one leg in contact with one of the surfaces being measured. (See fig. 2-11.) Then, as you increase the setting of the caliper, move the other leg from left to right. Feel for the slight drag indicating the proper setting of the caliper. Then, remove the caliper and measure the setting with a rule.

Measuring Hard-to-Reach Dimensions

To measure an almost inaccessible outside dimension, such as the thickness of the bottom of a cup, use an outside transfer firm-joint caliper as shown in

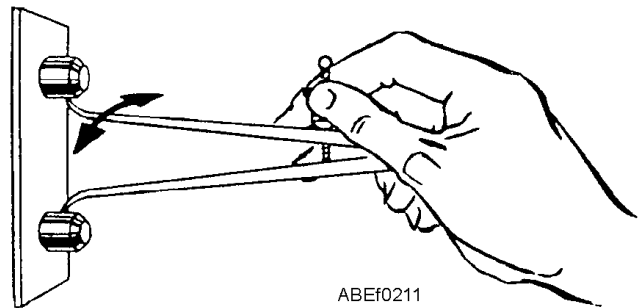

Figure 2-11.—Measuring the distance between two surfaces with an inside caliper.

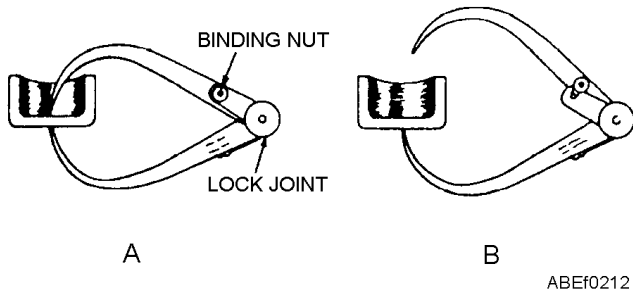

Figure 2-12.—Measuring the thickness of the bottom of a cup.

figure 2-12. When the proper "feel" is obtained, tighten the lock joint. Then, loosen the binding nut and open the caliper enough to remove it from the cup. Close the caliper again and tighten the binding nut to seat in the slot at the end of the auxiliary arm. The caliper is now at the original setting, representing the thickness of the bottom of the cup. The caliper setting can now be measured with a rule.

To measure a hard-to-reach inside dimension, such as the internal groove shown in figure 2-13, use an inside transfer firm-joint caliper. Use the procedure for measuring a hard-to-reach outside dimension.

Measuring Hole Diameters

To measure the diameter of a hole with an inside caliper, hold the caliper with one leg in contact with one side of the hole (fig. 2-14) and, as you increase the setting, move the other leg from left to right, and in and out of the hole. When you have found the point of largest diameter, remove the caliper and measure the caliper setting with a rule.

Setting a Combination Firm-Joint Caliper

To set a combination firm-joint caliper with a rule, when the legs are in position for outside measurements, grasp the caliper with both hands as shown in view A of figure 2-15, and adjust both legs to the approximate setting. After you adjust both legs, the shape of the tool

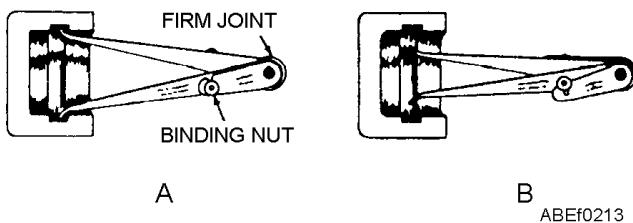

Figure 2-13.—Measuring a hard-to-reach inside dimension with an inside caliper.

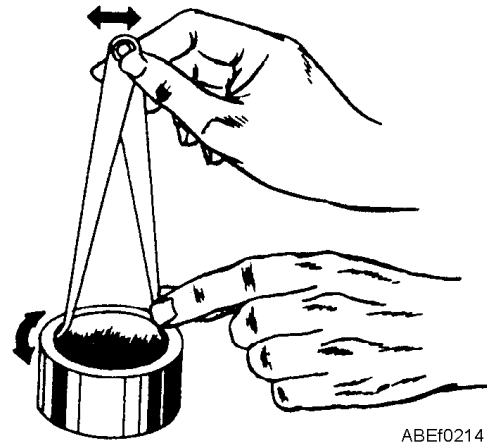

Figure 2-14.—Measuring an inside diameter with an inside caliper.

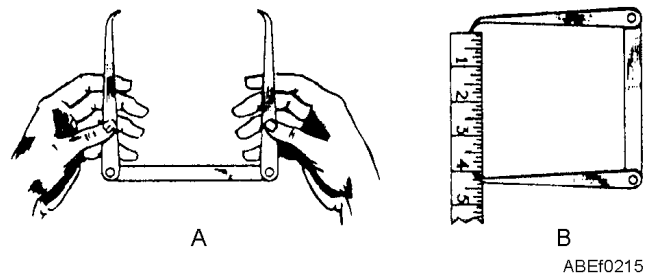

Figure 2-15.—Setting a combination firm-joint caliper.

will be approximately symmetrical. Thus, it will maintain its balance and be easier to handle.

Check this approximate setting as shown in figure 2-15, view B. Sight squarely across the leg at the graduations on the rule to get the exact setting required.

If it is necessary to decrease or increase the setting, tap one leg of the caliper as shown in figure 2-16. The arrow indicates the change in setting that will take place.

When the caliper is set for inside measurements, the same directions for adjusting the setting apply.

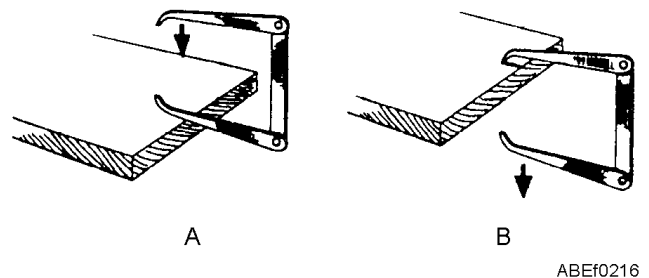

Figure 2-16.—Decreasing and increasing the setting of a firm-joint caliper.

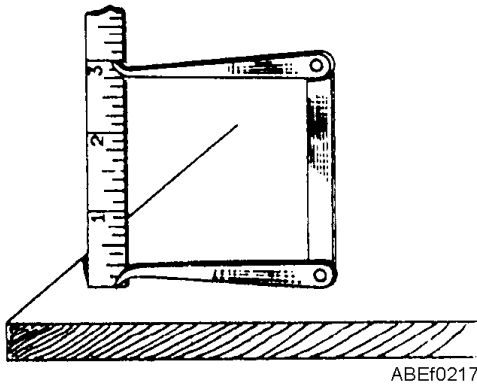

Figure 2-17.—Setting a combination firm-joint caliper for inside measurements.

Figure 2-17 shows how the end of the rule and one leg of the caliper are rested on the bench top so that they are exactly even with each other when the reading is taken.

Setting Outside and Inside Spring Calipers

To set a particular reading on an outside spring caliper, first open the caliper to the approximate setting. Then, as shown in figure 2-18, place one leg over the end of the rule, steadying it with the index finger. Make the final setting by sighting over the other leg of the caliper squarely with the face of the rule at the reading, and turning the knurled adjusting nut until the desired setting is obtained.

To set an inside spring caliper to a particular reading, place both caliper and rule on a flat surface as shown in figure 2-19. The rule must be held squarely or normal (90° in both directions) to the surface to ensure accuracy. Adjust the knurled adjusting nut, reading the setting on the rule with line-of-sight normal to the face of the rule at the reading.

Transferring Measurements from One Caliper to Another

To transfer a measurement from one spring caliper to another, hold the calipers as shown in figure 2-20.

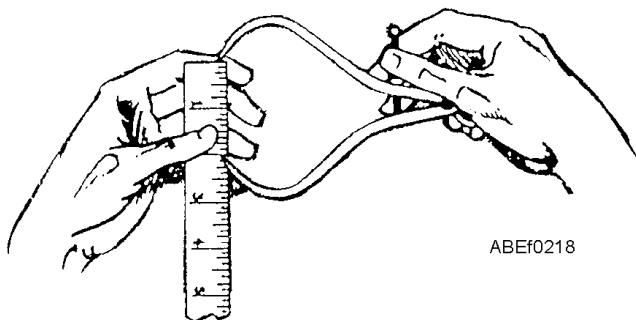

Figure 2-18.—Setting an outside spring caliper.

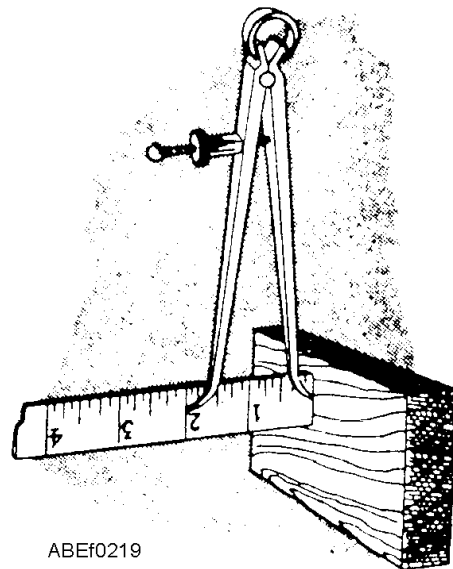

Figure 2-19.—Setting an inside spring caliper.

Note that one of the man's fingers is extended to steady the point of contact of the two lower caliper legs. In this figure the inside caliper is being adjusted to the size of the outside caliper. As careful measurements with calipers depend on one's sense of touch, which is spoken of as "feel," calipers are best held lightly. When you notice a slight drag, the caliper is at the proper setting.

CARE OF CALIPERS

Keep calipers clean and lightly oiled, but do not over oil the joint of firm-joint calipers or you may have difficulty in keeping them tight. Do not throw them around or use them for screwdrivers or pry bars. Even a slight force may spring the legs of a caliper so that other measurements made with it are never accurate. Remember that calipers are measuring instruments and must be used only for the purpose for which they are intended.

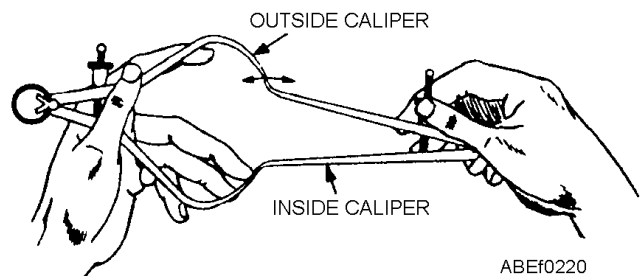

Figure 2-20.—Transferring a measurement from an outside to an inside caliper.

REVIEW QUESTIONS

- Q1. Identify the different types of measuring tools.
- Q2. Describe the uses of different types of measuring tools.
- Q3. Describe the proper care of measuring tools.

PRECISION MEASURING EQUIPMENT

LEARNING OBJECTIVES: Identify the different types of precision measuring tools. Describe the uses of different types of precision measuring tools. Describe the proper care of measuring tools. Maintain inventory and accountability of precision equipment.

In much wider use by ABEs than even common calipers are the various types of micrometer calipers. As was stated earlier, you can use micrometer calipers to take accurate measurements to the nearest one ten-thousandth of an inch. However, in most applications a measurement to the nearest one-thousandth of an inch is considered acceptable accuracy. These measurements are expressed or written as a decimal (0.0001, 0.001, 0.01), so you must know how to read and write decimals.

TYPES OF MICROMETER CALIPERS

There are three types of micrometer calipers, commonly called micrometers or simply mikes, used throughout the Navy: the outside micrometer, including

the screw thread micrometer; the inside micrometer; and the depth micrometer. (See fig. 2-21.) The outside micrometer is used for measuring outside dimensions, such as the outside diameter of a piece of round stock or the thickness of a piece of flat stock. The screw thread micrometer is used to determine the pitch diameter of screws. The inside micrometer is used to measure the inside diameter of a cylinder or hole. The depth micrometer is used for measuring the depth of a hole or recess.

Outside Micrometer

The nomenclature of an outside micrometer is illustrated in figure 2-22.

The sleeve and thimble scales of a micrometer (fig. 2-23) have been enlarged and laid out for demonstration. To understand these scales, you need to know that the threaded section on the spindle, which revolves, has 40 threads per inch. Therefore, every time the thimble completes a revolution, the spindle advances or recedes $1/40$ inch, or 0.025 inch.

Note the horizontal line on the sleeve is divided into 40 equal parts per inch. Every fourth graduation is numbered 1, 2, 3, 4, and so on, representing 0.100 inch, 0.200 inch, and so on. When you turn the thimble so its edge is over the first sleeve line past the 0 on the thimble scale, the spindle has opened 0.025 inch. If you turn the spindle to the second mark, it has moved 0.025 inch plus 0.025 inch, or 0.050 inch.

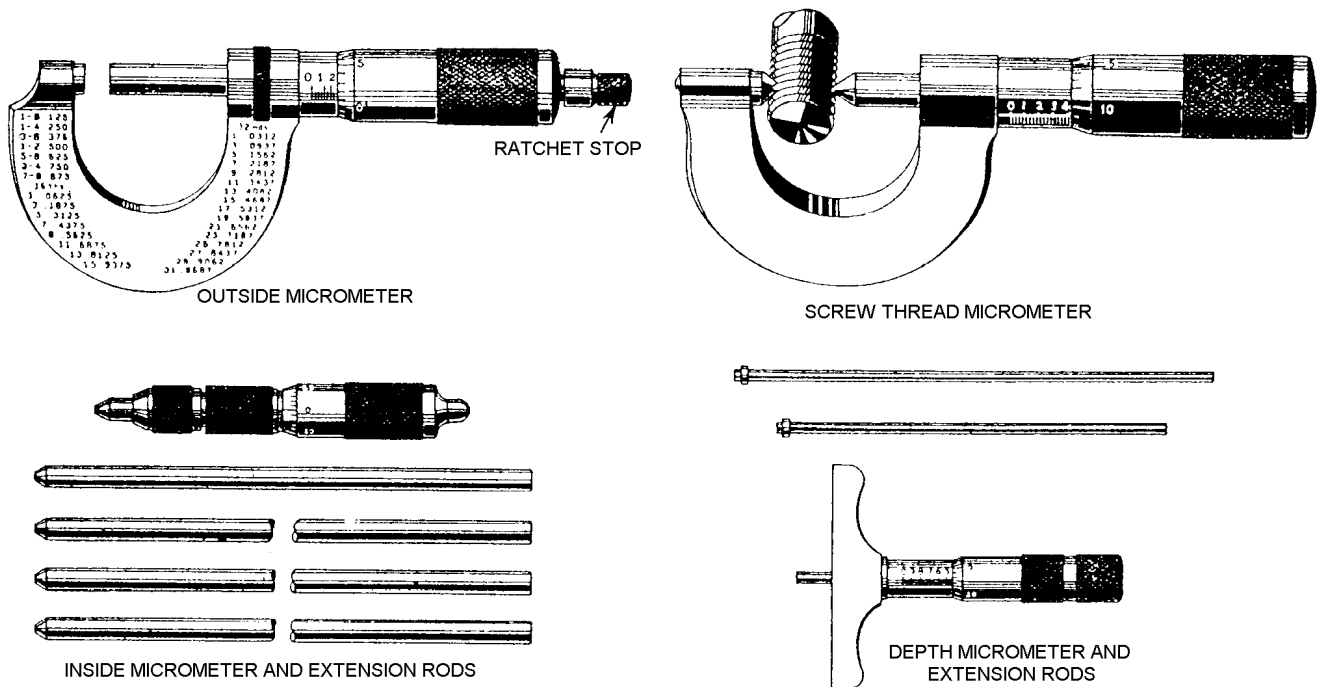

Figure 2-21.—Common types of micrometers.

ABE10221

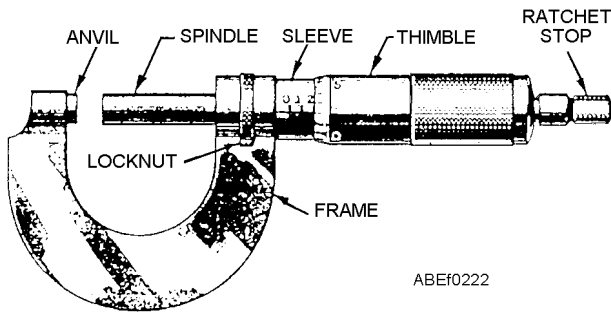

Figure 2-22.—Nomenclature of an outside micrometer caliper.

When the beveled edge of the thimble stops between graduated lines on the sleeve scale, you must use the thimble scale to complete your reading. The thimble scale is divided into 25 equal parts; each part or mark represents 1/25th of a turn. And, 1/25th of 0.025 inch equals 0.001 inch. Note that in figure 2-23 every fifth line on the thimble scale is marked 5, 10, 15, and so on. The thimble scale permits you to take very accurate readings to the thousandths of an inch.

The enlarged scale in figure 2-24 can help you understand how to take a complete micrometer reading to the nearest thousandth of an inch.

The thimble is turned far enough to expose the 7 on the sleeve scale but not far enough to expose the first mark after the 7. Therefore, the measurement must be between 0.700 inch and 0.725 inch. Exactly how far between 0.700 inch and 0.725 inch must be read on the thimble scale.

As you can see, the thimble has been turned through 12 spaces of its scale, and the 12th graduation

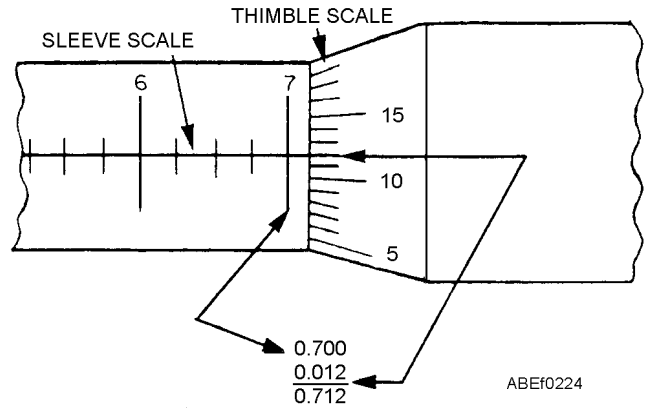

Figure 2-24.—Enlarged micrometer scale.

is lined up with the reference line on the sleeve. When the value on the sleeve scale is added to the value on the thimble scale that is lined up with the reference line on the sleeve scale, the space between the anvil and spindle must be 0.712 inch (seven hundred and twelve thousandths of an inch).

MICROMETER-READING EXERCISE.—

Occasionally you attain a reading in which the horizontal reference line of the sleeve scale falls between two graduations on the thimble scale, as shown in figure 2-25. Note the horizontal reference line is closer to the 15 mark than to the 14 mark. To read this measurement to **THREE** decimal places, simply round off to the 15 mark, as shown in example A of figure 2-25. To read this measurement to **FOUR** decimal places, estimate the number of tenths of the distance between thimble scale graduations the horizontal reference line has fallen. Each tenth of this distance equals one ten-thousandth (0.0001) of an inch. Add the ten-thousandths to the reading as shown in example B of figure 2-25.

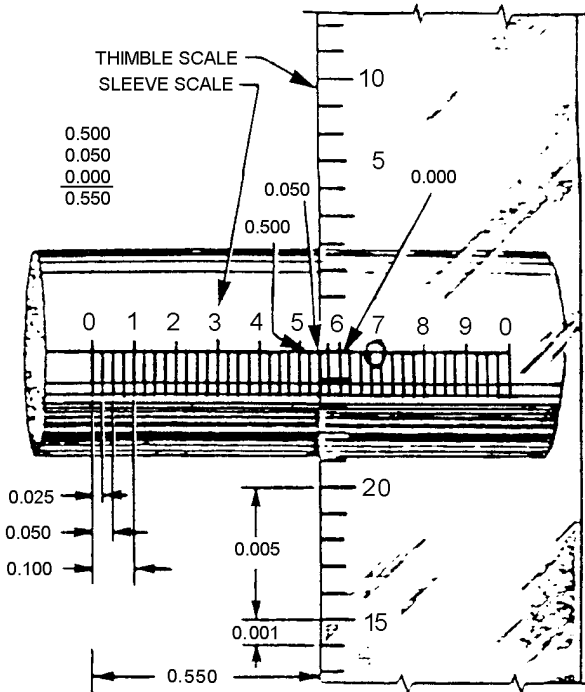
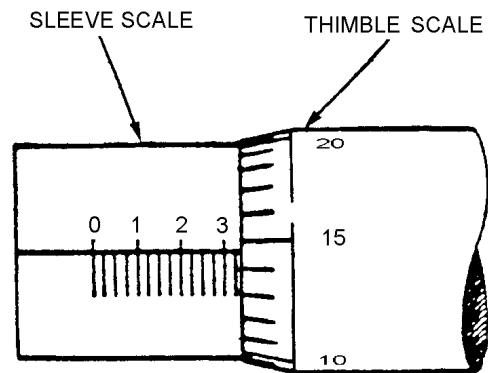

Figure 2-23.—Sleeve and thimble scales of a micrometer.



A	{	$\begin{array}{r} 0.300 \\ 0.025 \\ 0.015 \\ \hline 0.340 \end{array}$	B	{	$\begin{array}{r} 0.300 \\ 0.025 \\ 0.014 \\ 0.0007 \\ \hline 0.3397 \end{array}$
---	---	--	---	---	---

ABEF0225

Figure 2-25.—Reading sleeve and thimble scales of a micrometer.

READING THE VERNIER SCALE ON A MICROMETER.—Many times you are required to work to exceptionally precise dimensions. Under these conditions it is better to use a micrometer that is accurate to ten-thousandths of an inch. This degree of accuracy is obtained by the addition of a vernier scale.

The vernier scale of a micrometer (fig. 2-26) furnishes the fine readings between the lines on the thimble rather than requiring you to estimate the reading. The 10 spaces on the vernier are equivalent to 9 spaces on the thimble. Therefore, each unit on the vernier scale is equal to 0.0009 inch, and the difference between the sizes of the units on each scale is 0.0001 inch.

When a line on the thimble scale does not coincide with the horizontal reference line on the sleeve, you can determine the additional spaces beyond the readable thimble mark by finding which vernier mark matches up with a line on the thimble scale. Add this number, as that many ten-thousandths of an inch, to the original reading. In figure 2-27 see how the second line on the vernier scale matches up with a line on the thimble scale.

This means that the 0.011 mark on the thimble scale has been advanced an additional 0.0002 beyond the horizontal sleeve line. When you add this to the other readings, the reading is $0.200 + 0.075 + 0.011 + 0.0002$, or 0.2862, as shown.

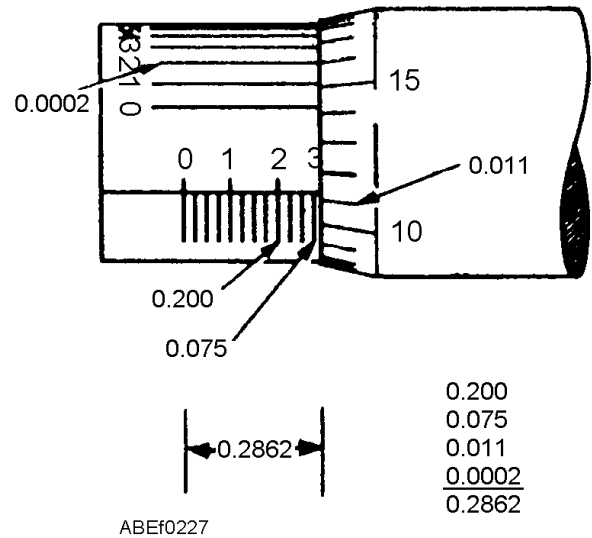

Figure 2-27.—Reading a vernier scale micrometer.

Inside Micrometer

The inside micrometer, as the name implies, is used for measuring inside dimensions, such as pump casing wearing rings, cylinder, bearing, and bushing wear. Inside micrometers usually come in a set that includes a micrometer head, various length spindles (or extension rods) that are interchangeable, and a spacing collar that is 0.500 inch in length. The spindles (or extension rods) usually graduate in 1-inch increments of range; for example, 1 to 2 inches, 2 to 3 inches (fig. 2-28).

The 0.500 spacing piece is used between the spindle and the micrometer head so the range of the micrometer can be extended. A knurled extension handle is usually furnished for obtaining measurements in hard-to-reach locations.

Reading the inside micrometer. To read the inside micrometer, read the micrometer head exactly as you would an outside micrometer, then add the micrometer reading to the rod length (including spacing collar, when installed) to obtain the total measurement.

Depth Micrometer

The depth micrometer is used to measure the precise depths of holes, grooves, and recesses by using interchangeable rods to accommodate different depth measurements (fig. 2-21). When using a depth micrometer, you must make sure the base of the micrometer has a flat, smooth surface to rest on and that it is held firmly in place to ensure an accurate measurement (fig. 2-29).

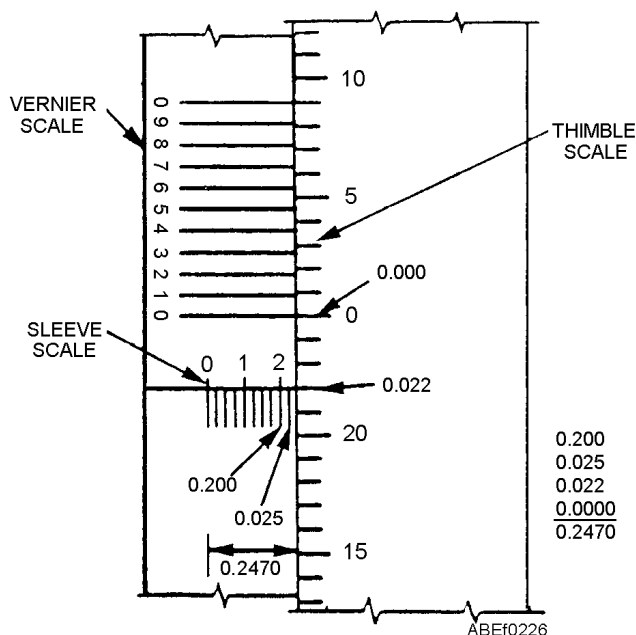
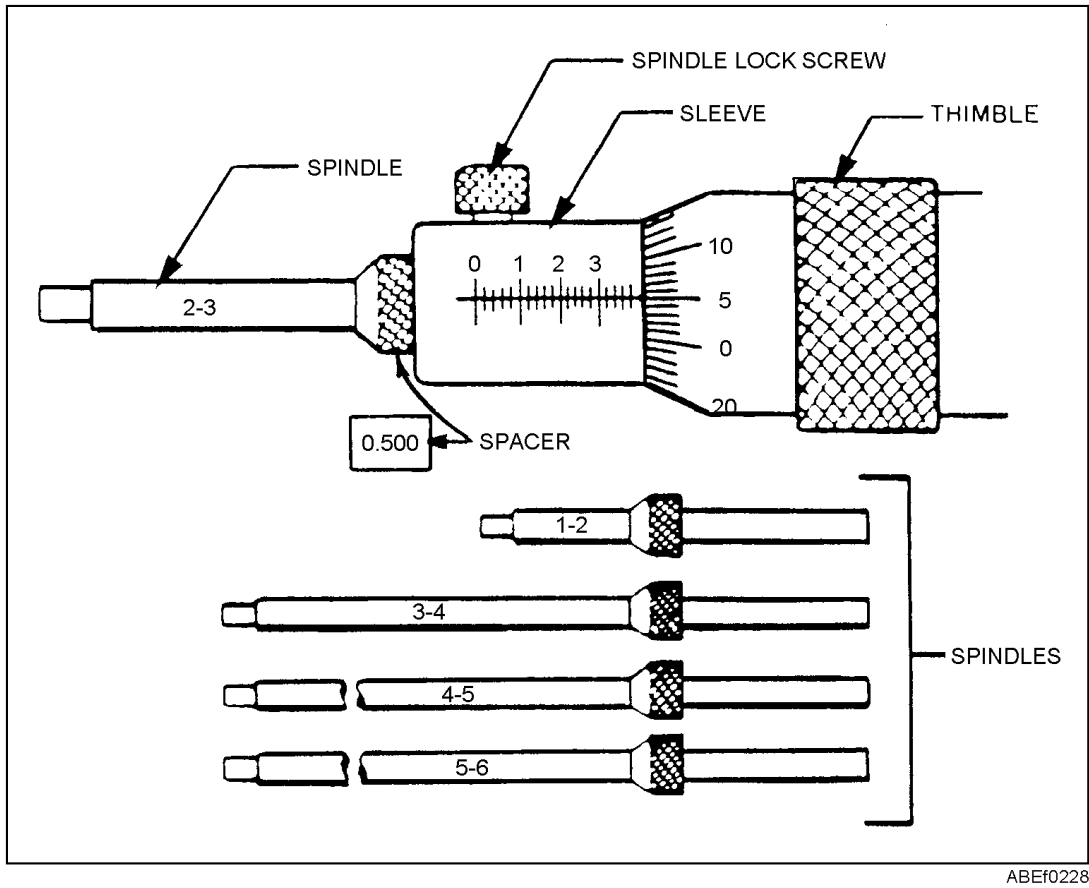

Figure 2-26.—Vernier scale of a micrometer.



ABEF0228

Figure 2-28.—Inside micrometer set.

Reading a depth micrometer. When reading a depth micrometer, you will notice that the graduations on the sleeve are numbered in the opposite direction of those on an outside or inside micrometer. When you are reading a depth micrometer, the distance to be measured is the value that is covered by the thimble.

See figure 2-30; consider the reading shown. The thimble edge is between the numbers 4 and 5. This shows a value of at least 0.400 inch on the sleeve's major divisions. The thimble also covers the first minor division on the sleeve; this has a value of 0.025 inch. The value shown on the thimble circumference scale is 0.010 inch. Adding these three values together results in a total of 0.435 inch, or the total distance that the end of the extension rod has traveled from the base. This measurement added to the length of the extension rod used gives you the total depth of the hole, recess, or groove that was measured.

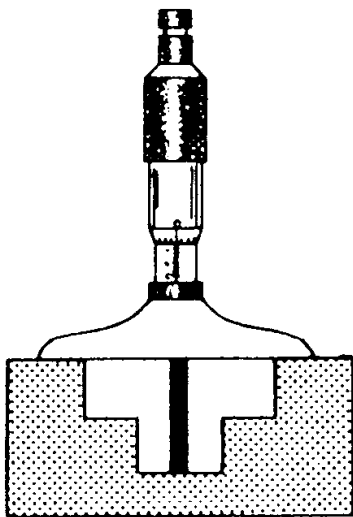

ABEF0229

Figure 2-29.—Using a depth micrometer.

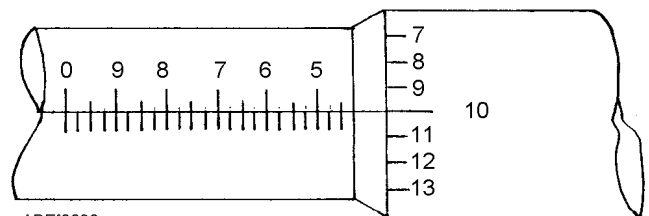

ABEF0230

Figure 2-30.—Depth micrometer sleeve and thimble scales.

SELECTING THE PROPER MICROMETER

The types of micrometers commonly used are made so that the longest movement that the micrometer spindle or rod can make is 1 inch. This movement is called the range; for example, a 2-inch micrometer has a range of from 1 inch to 2 inches, and can only measure work with a thickness or diameter within that range. Therefore, it is necessary to first determine the approximate size, to the nearest inch, of the work to be measured and then select the proper size micrometer. The size of a micrometer indicates the size of the largest work it can measure.

CARE OF MICROMETERS

Keep micrometers clean and lightly oiled. Make sure they are always stored in a case or box when not in use, to protect them from damage. Never clean any part of a micrometer with emery cloth or other abrasive. The measuring tools that have been described in this chapter are the ones that you, as an ABE, will routinely use while performing your assigned duties. You may, however, occasionally be required to use other less commonly used measuring tools. Some of these are the dial indicator, telescopic (snap) gauge, the vernier caliper, or screw thread gauge. The description of these tools and instructions for their use can be found in the training manual Use and Care of Hand Tools and Measuring Tools, NAVEDTRA 12085.

INVENTORY AND ACCOUNTABILITY

All measuring tools will be marked in some manner, etched, stenciled, etc., to comply with standard inventory instructions. These standard instructions may be found in Aircraft Launch and Recovery Equipment (ALRE) Tool Control Manual, NAEC-MISC-51-OR732.

Some measuring tools such as tapes and calipers may be part of a specific toolbox inventory. Other precision measuring instruments such as micrometers,

snap gauges and vernier calipers will normally be maintained in the division's central tool room. Regardless of the tool's permanent location, it is always the user's responsibility to maintain, care for and use the tool properly.

Damage, loss, or an improperly working tool should be reported immediately. Loss of a tool becomes especially critical when working on or around the catapult or arresting gear machinery. The tool may be "lost" in the machinery and, if not found, may cause catastrophic damage to the equipment and serious injury to personnel. Always double-check the inventory ensuring every tool is accounted for upon job completion. The proper tools will help you maintain your equipment but only if you maintain your tools properly.

REVIEW QUESTIONS

- Q4. *Identify the different types of precision measuring tools.*
- Q5. *Describe the uses of different types of precision measuring tools.*
- Q6. *Describe the proper care of precision measuring tools.*
- Q7. *All precision measuring tools will be _____ in some manner to comply with the standard inventory instructions found in NAEC-MISC-51OR732.*

SUMMARY

This chapter has introduced you to some of the most often used measuring tools and the techniques for using them. Selecting the proper tool; using and maintaining the various tools; and inventorying the tools have all been discussed. By thoroughly understanding and comprehending this chapter, you, as an ABE, will be able to perform your daily duties more efficiently and safely.

CHAPTER 3

MK 7 AIRCRAFT RECOVERY EQUIPMENT

Present-day aircraft normally require the use of runways that are 5,000 to 8,000 feet long in order to land ashore. On an aircraft carrier, these same aircraft are stopped within 350 feet after contacting the deck. This feat is accomplished through the use of aircraft recovery equipment, including an emergency barricade that brings a landing aircraft to a controlled stop by absorbing and dispelling the energy developed by the landing aircraft. This recovery equipment is commonly called arresting gear.

The sole purpose of an aircraft carrier is to provide a means of launching a strike against an enemy anywhere in the world. After the aircraft complete their mission, the carrier must provide a means of safely recovering them. The Mk 7 arresting gear provides this means.

AIRCRAFT RECOVERY

LEARNING OBJECTIVE: Describe aircraft arrestments aboard aircraft carriers. Describe prerecovery preparations. Describe normal aircraft recovery operations. Describe emergency aircraft recovery operations.

Aircraft arrestments aboard carriers are classified as either a normal arrestment or an emergency arrestment. Simply stated, arrestment is accomplished in the following manner: the arresting hook of the incoming aircraft engages a wire rope cable, called a deck pendant, that spans the flight deck in the landing area. The force of the forward motion of the aircraft is transferred to purchase cables that are reeved around a movable crosshead of sheaves and a fixed sheave assembly of the arresting engine (see fig. 3-1). The movable crosshead is moved toward the fixed sheave assembly as the aircraft pulls the purchase cables off the arresting engine, forcing a ram into the cylinder holding pressurized hydraulic fluid (ethylene glycol). This fluid is forced out of the cylinder through a control valve that meters the flow to an accumulator until the aircraft is brought to a smooth, controlled arrested landing (see fig. 3-2).

After arrestment, the aircraft's arresting hook is disengaged from the deck pendant. A retract valve is

then opened, allowing fluid to be forced from the accumulator back into the engine cylinder, forcing the ram out. As the ram moves out of the cylinder, the crosshead is forced away from the fixed sheave assembly, pulling the purchase cables back onto the engine until the crosshead is returned to its BATTERY position and the crossdeck pendant is in its normal position on the flight deck.

PRERECOVERY PREPARATIONS

Prior to recovery of aircraft, all recovery equipment and landing area must be made ready and all personnel properly positioned. The following is a general listing of the events that must be accomplished prior to the recovery of aircraft:

- All operational retractable sheaves raised to the full up position
- All aft deckedge antennas positioned, as required
- Ready barricade, including deck ramps, in a ready status with a clear route to the landing area and a tractor with driver standing by
- All launching accessories clear of the landing area
- Appropriate catapult shuttle(s) (as applicable) are aft with the grab latch disengaged and the shuttle spreader cover installed
- The catapult centerdeck hatch and any other hatches in the waist catapult area closed and dogged down
- Jet Blast Deflectors (JBDs) completely lowered and hydraulics secured
- Waist catapult safety light in the down position, if applicable
- Catapult #3 track slot buttons installed
- Waist catapult Integrated Catapult Control Station (ICCS) fully lowered, if applicable

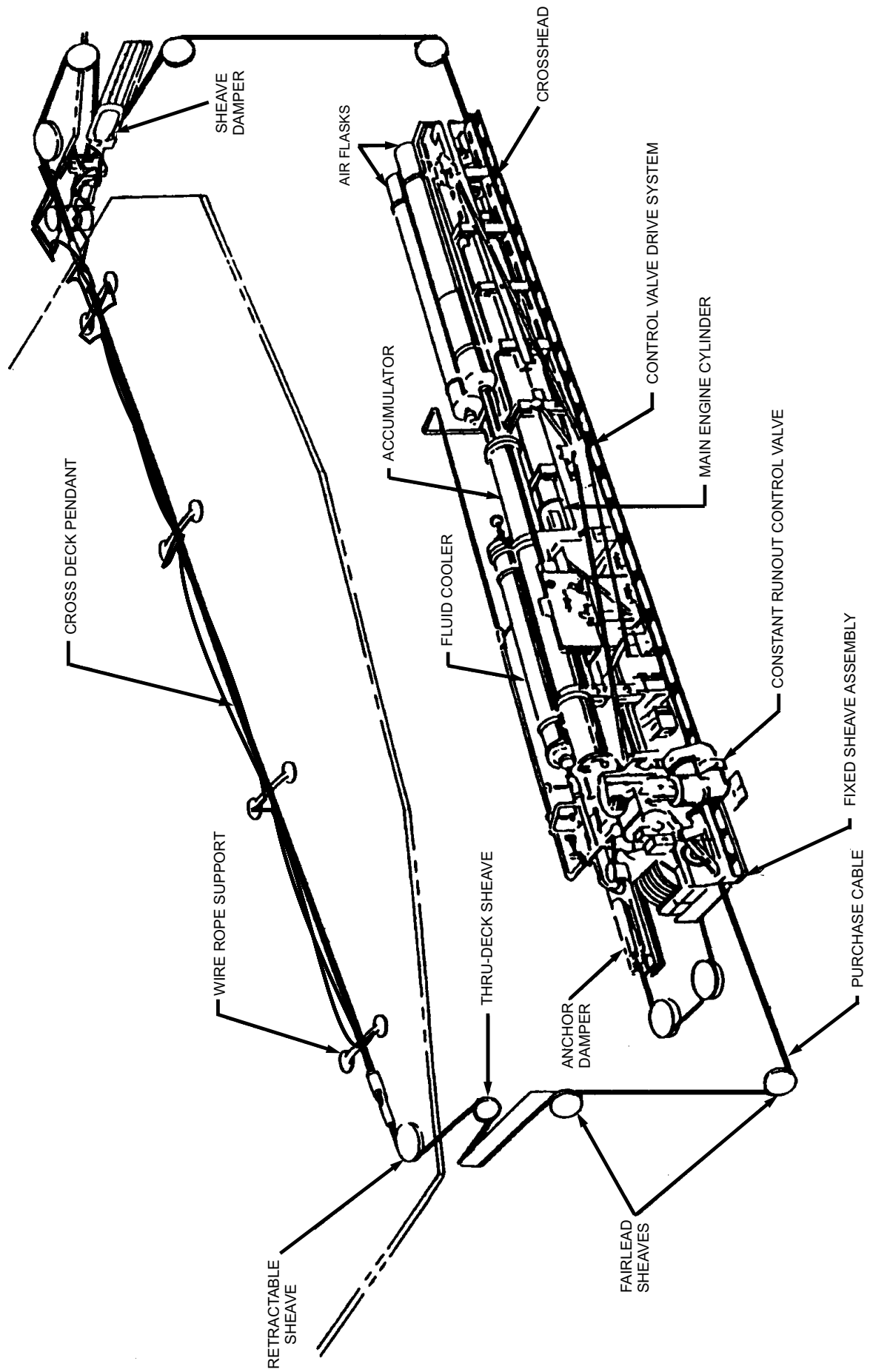

ABE10301

Figure 3-1.—General arrangement of Mk 7 arresting engine with cooler.

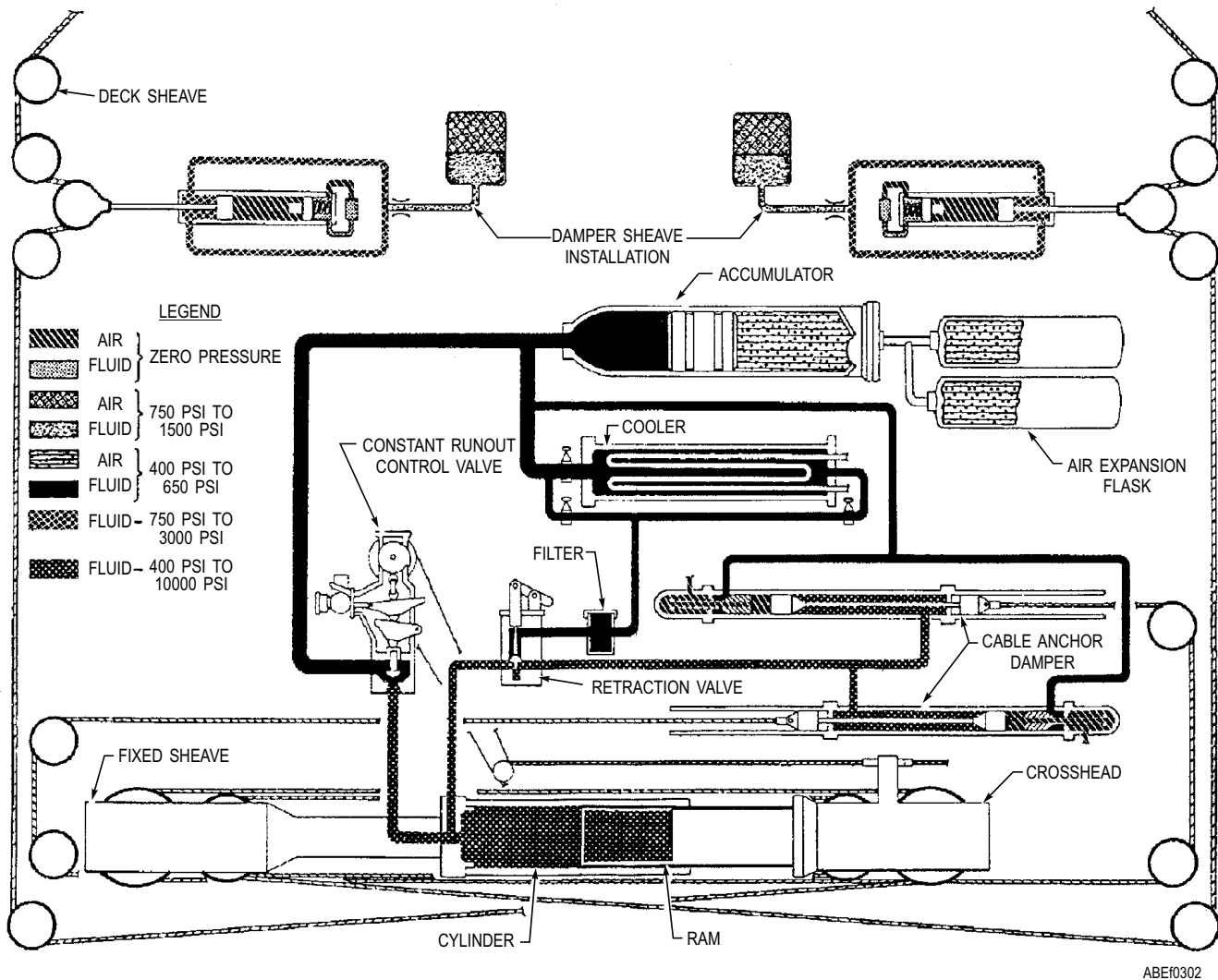

ABEF0302

Figure 3-2.—Mk 7 Mod 3 fluid flow diagram during arrestment.

- Landing area clear of aircraft or any other obstructions
- Aircraft recovery green rotating beacon on
- All stations manned and ready with voice communication established and reports made to the air officer
- Sheave and anchor damper in the battery position
- All engines fully retracted and crossdeck pendant at the proper height
- Engine fluid levels in the battery range and accumulator pressure at 400 psi
- Received from the air officer; aircraft type to be recovered
- Determine proper aircraft weight setting in accordance with applicable aircraft recovery bulletin
- Direct the engine room operators to set their respective engine and verify that correct weight has been set
- Pickle switch is actuated, lighting the green clear deck landing status light

NORMAL RECOVERY OPERATIONS

Normal recovery operations involve the recovery of aircraft with no equipment failure or damage that precludes the aircraft from recovering at the prescribed air speed or proper landing configuration.

Prior to commencing aircraft recovery operations, the following considerations apply:

All arresting gear equipment is in normal operating condition and all Maintenance Requirement Cards (MRCs) preoperational requirements have been met.

All personnel involved in recovery operations have completed the applicable Personnel Qualification Standards (PQS) and are fully qualified to perform their assigned tasks. Personnel not yet qualified may be utilized, but only if under the direct supervision of a fully PQS qualified crewmember.

EMERGENCY RECOVERY OPERATIONS

An emergency arrestment is accomplished in the same manner as a normal arrestment except that a barricade webbing assembly transmits the aircraft's landing force to the purchase cable instead of a crossdeck pendant.

ARRESTING ENGINE

LEARNING OBJECTIVE: Describe the components of the arresting engine.

The Mk 7 arresting engine is a hydropneumatic system composed of the engine structure, a cylinder and ram assembly, a crosshead and fixed sheaves, a control valve system, an accumulator system, air flasks, and a sheave and cable arrangement.

Improvements are continuously being made to increase the capabilities of carrier-based aircraft. As the capabilities of the aircraft are increased, the weight and speed also increase. Therefore, the equipment used to recover the aircraft aboard carriers must also be improved to keep pace with aircraft advancement. Such improvements have brought about the recovery equipment installed on our carriers in the fleet today—the Mk 7 Mod 3.

All pendant and barricade engines are Mk 7 Mod 3, except the barricade engines installed on CV-64 and CVN-65, which are Mk 7 Mod 2. For more information on the Mk 7 Mod 2 refer to *Operational and Organizational/Intermediate Maintenance Manual, NAVAIR 51-5BBA-2.1 and 2.2*. Table 3-1 lists the leading particulars of the Mk 7 Mod 3 recovery equipment.

ENGINE STRUCTURE

The engine structure is a framework for supporting the engine and most of its components and for securing the entire assembly to the ship's structure. It is composed of a welded steel base made in two longitudinal box sections with the necessary ties, plates, and other structural members. The two sections are bolted together near the center. See figure 3-1.

Two pairs of saddles are mounted on the base for supporting the engine cylinder. Vertical stands are welded on these saddles to support the saddles for the accumulator. Between these two stands is a frame of welded channels, angles, and gusset plates to provide trusses and ties for the frame.

On the crosshead end of the welded base support plates, webs and gussets support the rails for the crosshead. On this end of the base are welded longitudinal guides for the accumulator assembly. Near the end of this frame and bolted to it is the crosshead stop, which is removed when the crosshead is installed or removed.

CONSTANT RUNOUT VALVE (CROV) ASSEMBLY

The constant runout valve (CROV) is installed at the fixed sheave end of the Mk 7 arresting engine, as illustrated in figure 3-1. It is designed to stop all aircraft with the same amount of runout regardless of the aircraft's weight and speed (within the limits specified in current recovery bulletins).

The CROV is the heart of the equipment. It controls the flow of fluid from the cylinder of the arresting engine to the accumulator. The other components of the valve are used either to adjust the initial opening of this valve for aircraft of different weight or to activate the valve during the arresting stroke.

CONSTANT RUNOUT VALVE (CROV) DRIVE SYSTEM

When a landing aircraft engages a deck pendant, or barricade, it withdraws purchase cable from the arresting engine. This action causes the crosshead to move toward the fixed sheave end of the engine. In addition to causing fluid displacement from the engine cylinder, the movement of the crosshead causes the CROV drive

Table 3-1.—Leading Particulars of Mk 7 Mod 3 Recovery Equipment

MAXIMUM ENERGY ABSORPTION	47,500,000 ft-lb
ENGINE DRIVE SYSTEM CABLES:	
Breaking strength/diameter	
Deck pendant (6 × 30 flat strand hemp core)	188,000 lb/1 3/8 in.
Purchase cable (6 × 25 round strand hemp core)	195,000 lb/1 7/16 in.
Deck pendant (6 × 30 flat strand polyester core)	205,000 lb/1 7/16 in.
Purchase cable (6 × 31 flat strand polyester core)	215,000 lb/1 7/16 in.
Reeving ratio	18 to 1
3312DAMPER SHEAVE INSTALLATION:	
Damper sheave service stroke	10 ft
Effective piston area of damper sheave piston	39.27sq. in.
ARRESTING ENGINE:	
Length	50 ft
Weight	43 tons
Engine fluid	Ethylene glycol
Engine fluid capacity (without cooler)	380 gal
Engine fluid capacity (with cooler)	560 gal
Type of coolant	Sea water
Ram diameter	20.000 in.
Effective ram area	314.16 sq. in.
Length of two-stroke	195 in.
Length of service stroke	
Pendant engine	183 in.
Barricade engine	160 in.
Crosshead battery position	1 to 7 in. (new cable)
(distance from stop)	1 to 6 in. (old cable)
Accumulator operating medium	Hydraulic fluid — Air
Initial working pressure	400psi
Maximum pressure	650 psi
Length of deck pendant runout	344 ft (to tail hook)
Length of barricade runout	388 ft (to nose wheel)
Cable anchor damper piston service stroke	15 ft 8 in.
Effective piston area of cable anchor damper piston	7.85 sq. in.
BARRICADE POWER PACKAGE	
Power package fluid	Catapult hydraulic fluid
Power package fluid capacity	125 gal
Power package operating medium	Hydraulic fluid — Air
Initial working pressure	1,500 psi
Pressure switch minimum pressure	1,250 psi
Relief valve maximum pressure	1,750 psi

system (fig. 3-3) to rotate the CROV cam. Rotation of this cam forces a plunger down onto a set of levers (fig. 3-4), which in turn forces a valve sleeve and valve stem down to mate with a valve seat to close the valve, shutting off the flow of fluid from the engine cylinder to the engine accumulator, bringing the aircraft to a stop.

As stated earlier, the CROV is designed to bring all aircraft, regardless of weight, to a controlled stop while using approximately the same amount of flight deck landing area. This is accomplished by adjusting the allowable opening of the CROV, a smaller, more restrictive opening to arrest a heavy aircraft or a large valve opening to arrest a light aircraft.

CONSTANT RUNOUT VALVE (CROV) WEIGHT SELECTOR

The aircraft weight selector makes it possible to adjust the CROV for aircraft of different weights by varying the valve opening. See figure 3-4.

The size of the initial valve opening is adjusted while the arresting engine is in the BATTERY position. The lead screw receives rotary motion from the motor unit or handwheel and converts it into linear motion. This linear motion positions the upper lever and drives the local and remote indicators.

In each of the two levers (upper and lower), the distance between the fulcrum and roller is constant. On the upper lever, the distance between the fulcrum and

the point of application of force from the cam is variable, its greatest length being twice that of the lower lever. The lever arm ratio of each lever, therefore, is variable between 1:1 and 2:1.

When the upper lever is fully extended, the ratio of each lever is 1:1. In this setting the initial opening of the control valve upon engagement of an aircraft is maximum. The resulting rotation of the cam, caused by the crosshead moving inward, forces the plunger downward. A plunger movement of 1 inch, acting through the upper lever, would move the lower lever 1 inch; the lower lever, in turn, would move the valve sleeve and stem 1 inch downward.

The cam is a disc plate type with the desired contour machined on its periphery. As the cam rotates, it forces the plunger down. The plunger is fitted with rollers, top and bottom.

The bottom roller on the plunger acts against the top flat bearing surface of the upper lever. The pivot end of the upper lever has a bushed hole that mates with the clevis end of the lead screw yoke. The upper lever is connected to the clevis end of the yoke by a pin. This pin extends beyond the sides of the yoke and acts as a shaft and has a bushed roller mounted on each extended end. The rollers ride inside the guide attached to the housing. The block end of the yoke is connected to the lead screw by two dowel pins. This connection provides the means by which the lead screw adjusts (moves) the upper lever.

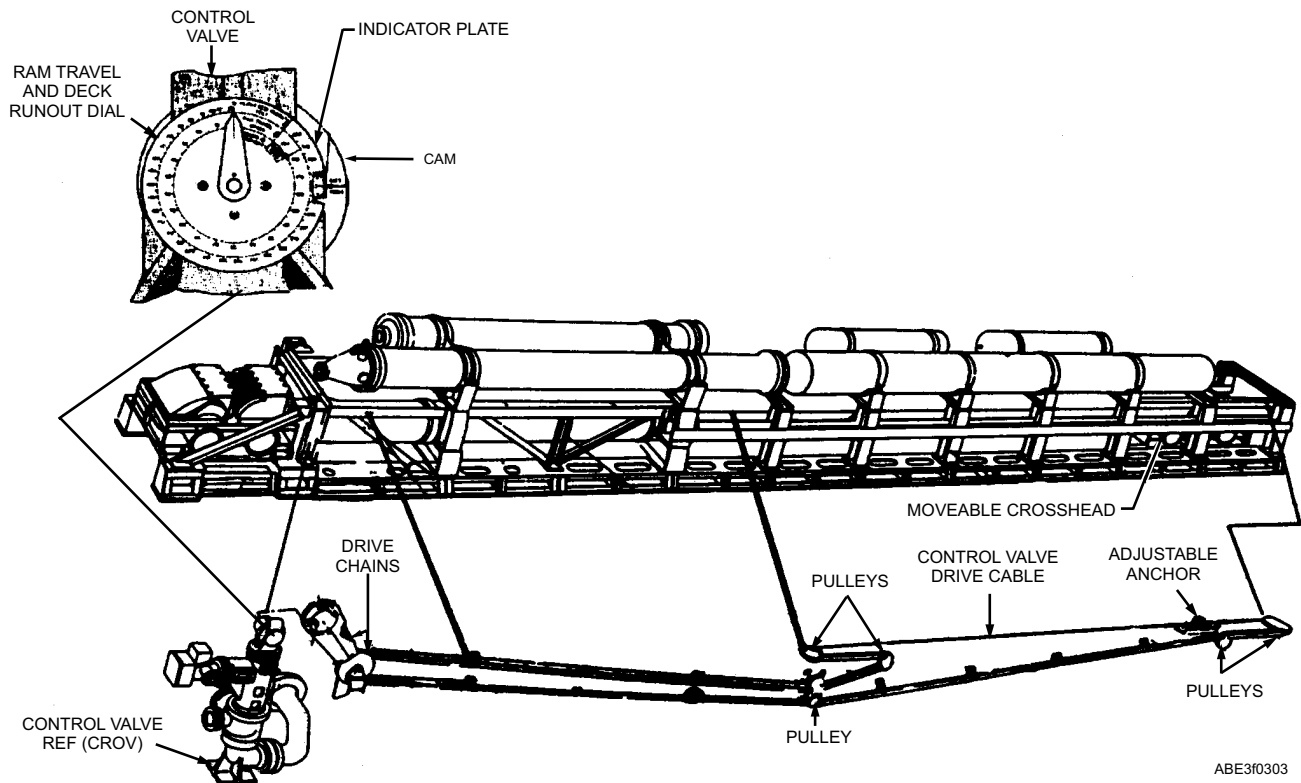

Figure 3-3.—Constant runout valve drive system.

The bottom of the upper lever is fitted with a roller that bears against the flat surface of the lower lever. One end of the lower lever has a bushed hole to receive a pivot pin. The pivot pin passes through the lever and through two mounting holes in the stanchion.

The bottom of the lower lever is fitted with a roller that bears on the stem screw on top of the valve sleeve. The vertical position of the roller on the lower lever determines the vertical distance that the valve sleeve may move. Thus, it controls the size of the initial opening of the control valve.

The levers are mounted in such a way that, as the upper lever is withdrawn, the lever arm ratio of both levers is increased by an equal amount. When the upper lever is fully withdrawn, the ratio of each lever is 2:1, and the ratio through the lever system (upper and lower levers) is 4:1. In this case the initial control valve

opening is minimum. A plunger movement of 1 inch, acting through the upper lever, would move the lower lever 1/2 inch; the lower lever, in turn, would move the valve sleeve and stem 1/4 inch downward.

A critical point to consider is the position of the levers when the valve stem is seated by cam action at the termination of each arrestment stroke. The levers are so mounted and adjusted that the bearing surfaces of the levers are level when the valve is seated. When the bearing surfaces are level, the distance across the lever system is the same regardless of the ratio setting. Because of this, the point of closing of the valve is independent of the aircraft weight selector. It is a function of the cam only; therefore, it is constant.

As the engine is retracted, the upper lever rises a distance equal to the movement of the plunger. If the ratio is 1:1, the valve sleeve rises the same distance. In

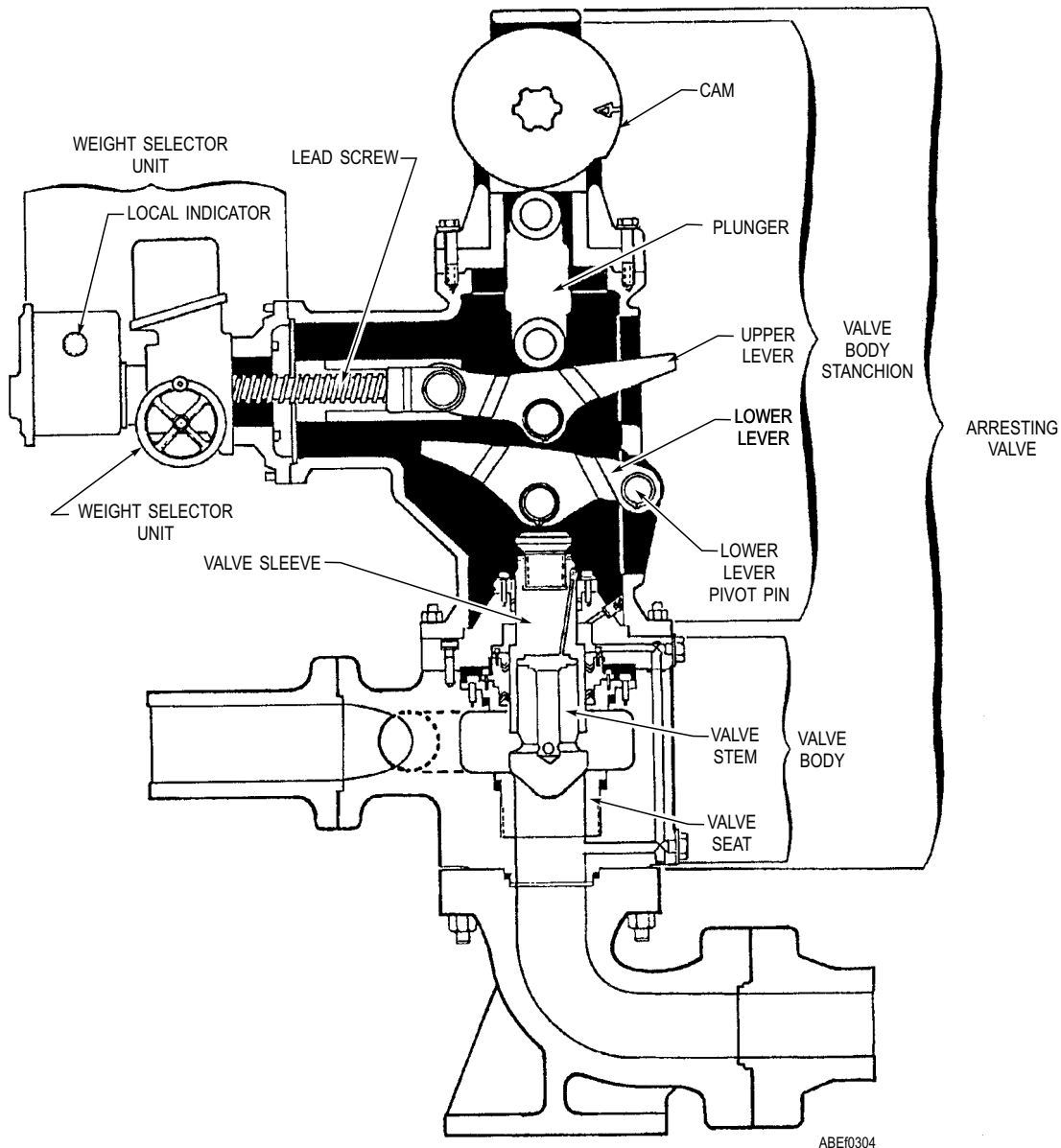

Figure 3-4.—Sectional view of Mk 7 CROV.

this case the initial valve opening is maximum. If the ratio is 4:1, however, the valve sleeve rises only one-fourth the distance that the plunger moves. In this case the initial valve opening is minimum.

The lever setting may be adjusted to any setting within the two extremes previously discussed; the particular setting used is dependent upon the weight of the aircraft to be arrested. The weight setting is made with the engine in battery position prior to landing the aircraft.

Adjustment of the setting determines the position of the valve sleeve. Therefore, it also sets the amount the valve will open at the beginning of the arrestment stroke. Similarly, it determines the rate of closure during the stroke so that the valve will always seat at the same runout.

The valve stem sleeve allows a relatively unloaded and cushioned opening at the beginning of the stroke.

The lever system, if set for a heavy aircraft, reduces the allowable valve stem opening and thus increases the resistance of the valve to the flow of fluid. The energy of the aircraft is dissipated by forcing fluid through the restricted valve opening.

ELECTRICAL SYSTEM

The electrical system provides, controls, and safeguards the distribution of electrical energy to the weight selector motor and the synchro indicators. The

electrical circuits (fig. 3-5) are the control valve weight selector circuit and the indicator circuit.

AIRCRAFT WEIGHT SELECTOR SYSTEM AND ELECTRICAL CIRCUIT

Due to the varying weights and landing speeds of carrier-based aircraft, it is necessary to vary the initial opening of the CROV and have a smaller initial opening for heavier aircraft than for lighter aircraft. The variation of the setting of the CROV is the function of the aircraft weight selector motor unit. (See fig. 3-5.) Normally, the settings are made electrically by depressing an increase or decrease push button located at the control valve. The settings can also be accomplished manually by a handwheel at the control valve.

The aircraft weight selector is motor operated from the 440-volt, 60-hertz, 3-phase ship's power supply. A fused switch box or breaker is provided to energize or de-energize the control circuit. To increase and decrease settings, the direction of the aircraft weight selector motor rotation is controlled by the motor controller. Should an electrical failure occur, the settings can be made manually by pulling out on the handwheel and turning in either the increase or the decrease direction.

Settings on the aircraft weight selector are monitored locally at the control valve motor unit dial and remotely by synchro receivers located at Pri-Fly and the deckedge control station.

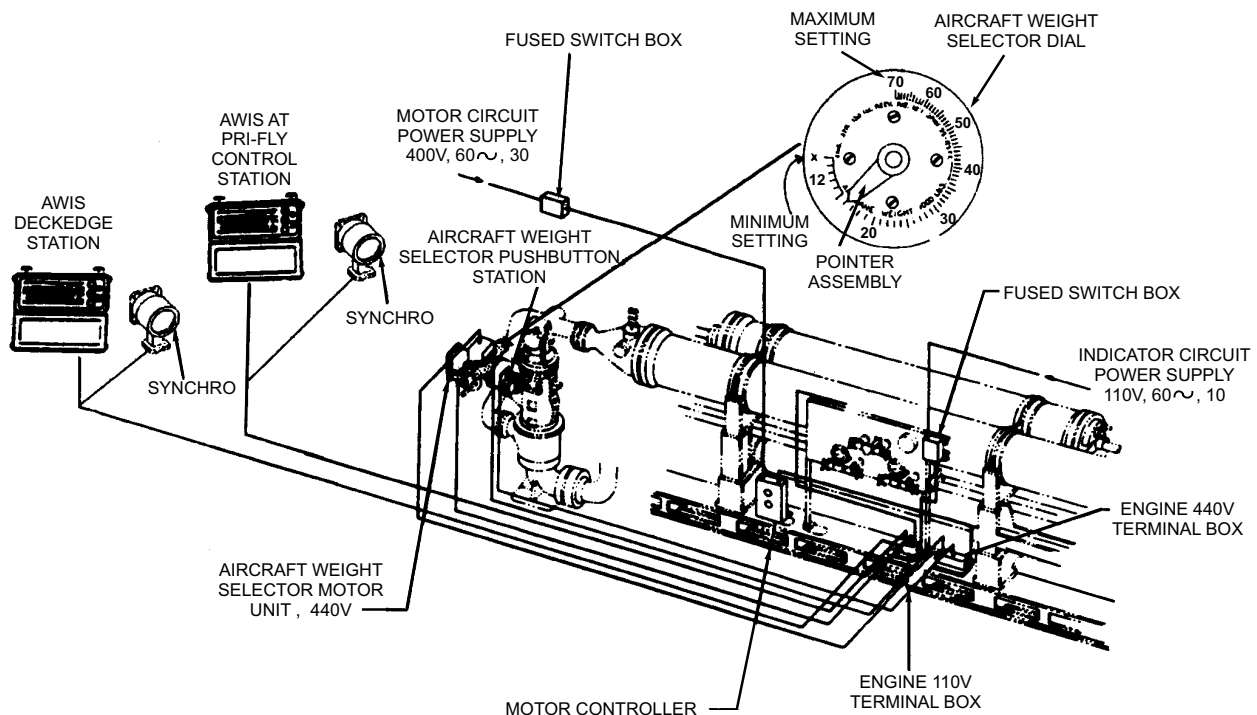

Figure 3-5.—Aircraft weight selector system.

ABE30305

PUSH-BUTTON STATIONS

The function of the push-button station is to select the proper contact of the weight selector motor controller so as to rotate the shaft of the motor in the proper direction to increase or decrease the weight setting

DECKEDGE CONTROL STATION

The deckedge control station (fig. 3-6) is located on the starboard side aft, where the operator has a clear, unobstructed view of the landing area.

The deckedge control station is equipped with control levers to retract each of the pendant engines and

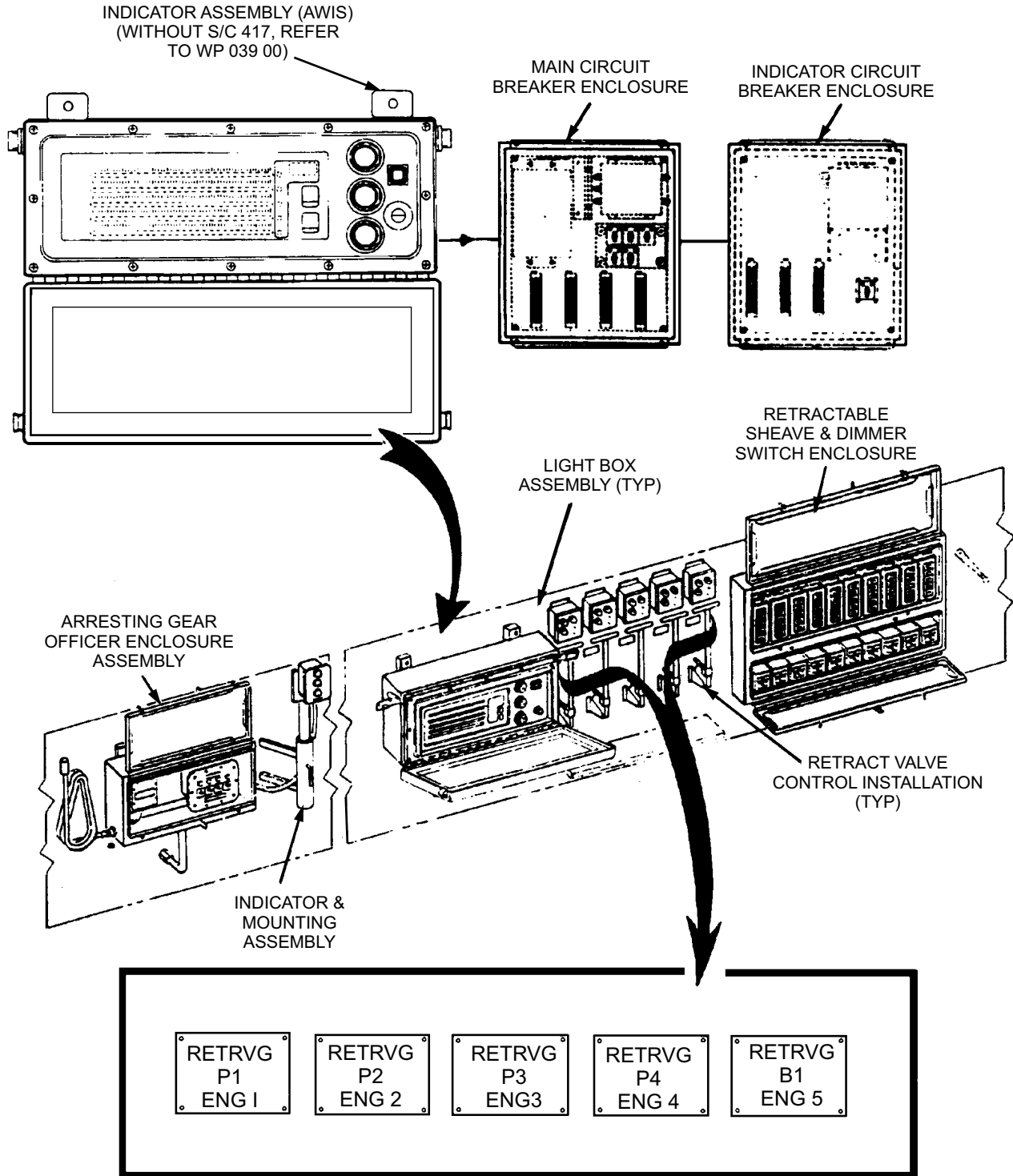

Figure 3-6.—Deckedge control station.

ABE30306

the barricade; a pressure gauge for the barricade hydraulic system; a control lever to raise or lower the barricade stanchions; push buttons to raise, lower, or stop the retractable sheaves; an indicator light to indicate their position; a battery position indicator light for the damper sheaves; and synchro receivers to monitor settings on the aircraft weight selector unit of each engine.

The deckedge control operator operates the controls from the gallery walkway and is equipped with sound-powered phones to maintain voice communications with the engine-room operator and Pri-Fly.

RETRACTING VALVE

The retracting valve permits the controlled return of fluid from the accumulator to the cylinder, thereby returning the engine to the BATTERY position. The general location of the retracting valve is shown in figure 3-7.

The retracting valve is a self-contained poppet-valve assembly composed principally of a housing, a plunger, an operating lever, a valve stem, and a valve seat.

The retracting valve operates as a check valve against the flow of fluid from the accumulator to the engine cylinder. Fluid at accumulator pressure enters the housing and bears on the stem in the direction that would open the valve; however, the pressure also bears against the base of the plunger, which tends to close the valve. Since the area of the plunger end is greater than that of the stem, the differential in force keeps the valve closed.

The retracting valve has piping that provides passage for engine fluid flow from the arresting engine, by way of the retracting valve, to the cable anchor dampers. A discharge port is provided where the retracting valve and pressure valve body are bolted together to allow fluid flow from the accumulator or fluid cooler into the main engine cylinder during retraction.

Retracting Valve Body

The retracting valve body is a hollow steel casting with an inlet port, connected by piping to the engine accumulator/fluid cooler manifold, a discharge port that is flanged and bolted to the engine cylinder outlet elbow, and a port connected by piping to the cable anchor dampers.

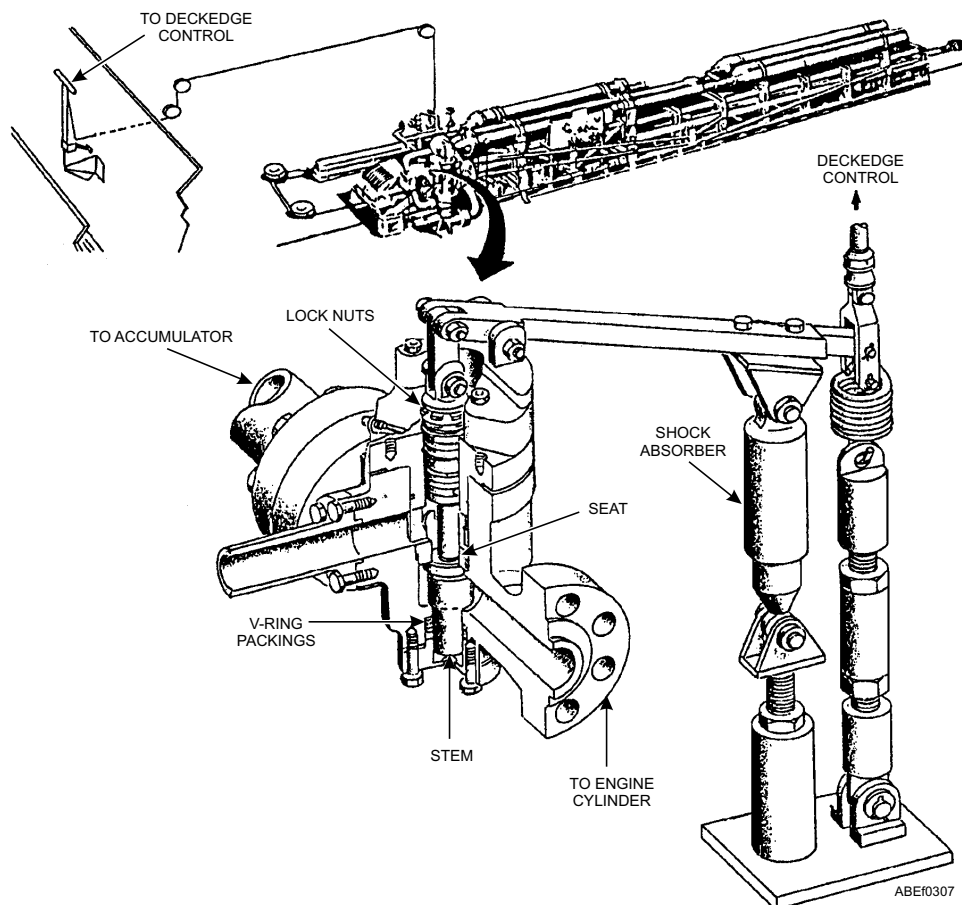

Figure 3-7.—General location of the retracting valve.

The valve body is bored and machined smooth inside to receive the valve seat. O-rings are provided as a seal between the valve body and the seat. The lower portion of the valve body has an inside machined recess for insertion of a V-ring packing assembly. The V-ring packing prevents leakage between the stem and valve body.

Valve Seat

The valve seat is a hollow, machined, cylindrical piece of bronze. One end is flanged and is bolted to the valve body, and the opposite end is machined to form a mating surface (seat) for the valve stem. Four vertical elongated holes are machined in the seat to allow fluid to enter the valve from the accumulator.

Valve Stem

The valve stem is a round piece of machined steel with a shoulder machined midway between the top and bottom. This shoulder mates with the valve seat and blocks fluid flow through the retract valve during arrestment and from the accumulator to the engine cylinder until retraction is desired.

Plunger

The plunger is a round piece of machined steel that is blind bored at one end to receive the shank of the valve stem. The plunger and valve stem are connected by a dowel pin. The opposite end of the plunger has a machined clevis and is externally threaded just below the clevis. The threaded portion is for an adjusting nut and a locknut used to adjust the stroke of the plunger and valve stem. The stroke is adjusted to 0.678 (11/16) of an inch. The clevis connects the operating lever and the plunger. The opposite end of the operating lever is connected to a tie rod, a return spring, and a control cable by another clevis. The control cable is attached to the T-shaped retracting handle at the deckedge control station. See figure 3-7.

RETRACTING LEVER

There is a retracting lever (fig. 3-8) for each arresting engine located at the deckedge control station. The retracting lever provides a remote means of opening the retracting valve from a location where the operator will have full visibility of recovery operations.

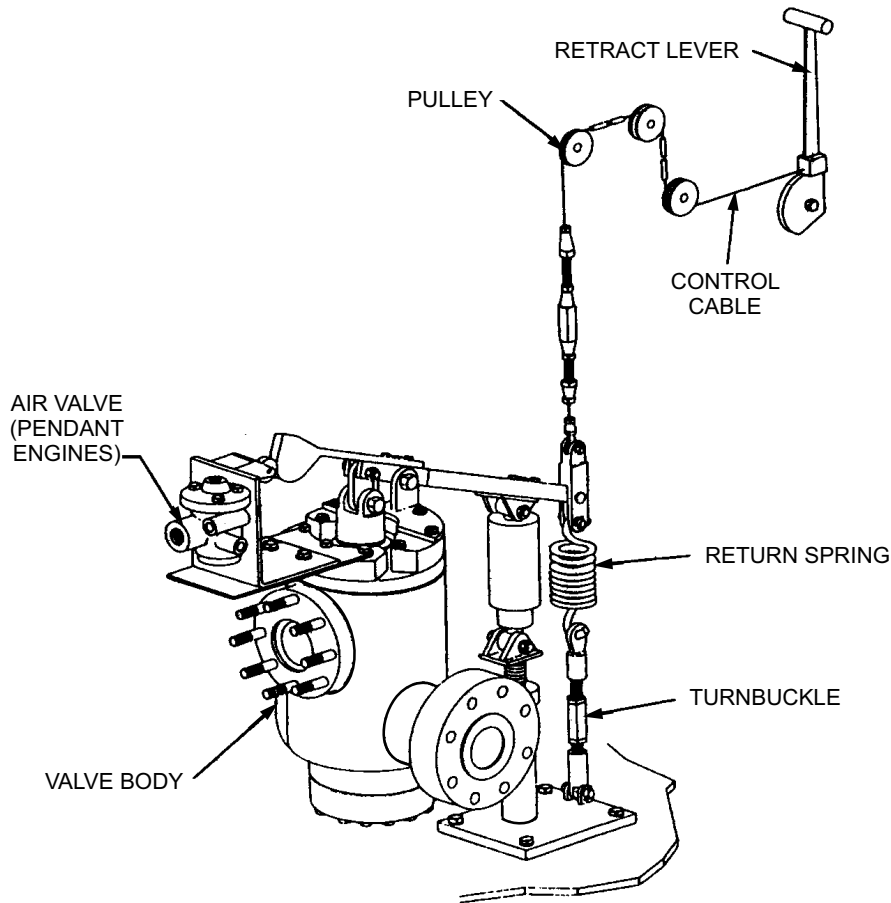

ABE30308

Figure 3-8.—Retracting valve and controls.

When the operator pulls down on the retracting lever, the force transmitted through the control cable lifts the end of the retracting lever that is attached to the return spring and tie rod. The retracting lever has a pivot point on the block mounting of the valve. As the one end of the retracting lever is lifted, the end connected to the plunger pushes down on the plunger and valve stem, allowing fluid flow through the valve from the accumulator or fluid cooler to the engine cylinder, thus forcing the ram and crosshead back to their battery position. After retraction is complete, the retracting lever is released and the return spring pulls down on the retracting lever, which in turn pulls up on the plunger and valve stem, which closes the valve. See figure 3-7.

The ideal condition is that tension be kept on the purchase cable from the beginning of the retracting stroke until the ram is in its battery position. An interruption of the stroke generally disrupts this condition and creates cable backlash, which results in cable slack on the engine.

If an emergency arises involving the safety of personnel or equipment, and an interruption of full-speed retraction is necessary, the following procedures are recommended to prevent possible damage, such as a tight kink, to the purchase cable:

1. Resume retracting very slowly at first to rid the cable system of slack.
2. Resume full-speed retraction only after the cable slack has been eliminated and the cable has tension.

3. Inspect sheave damper sheaves for proper seating of the purchase cable on completion of retraction.

A shock absorber like the one found on automobiles is installed on the operating lever to eliminate chattering of the retracting valve during closing.

ACCUMULATOR SYSTEM

LEARNING OBJECTIVE: Describe the accumulator system.

The Mk 7 Mod 3 arresting engine has a recirculating-type hydraulic system. During arrestment, the hydraulic fluid is forced from the main engine cylinder, through the CRO valve, to the accumulator. An initial air charge of 400 psi in the accumulator builds up to approximately 650 psi during arrestment. This increased pressure is used to force the fluid from the accumulator into the fluid cooler, thus forcing fluid from the previous arrestment, already cooled by the cooler, out of the cooler, through the retracting valve, and into the main engine cylinder, returning the engine to its BATTERY position.

The accumulator (fig. 3-9) is a long, steel cylinder mounted horizontally in saddles on the engine structure, with the fluid end toward the fixed sheaves. Inside the accumulator is a floating piston that separates the air side of the accumulator from the fluid side. The air end of the accumulator is flanged and

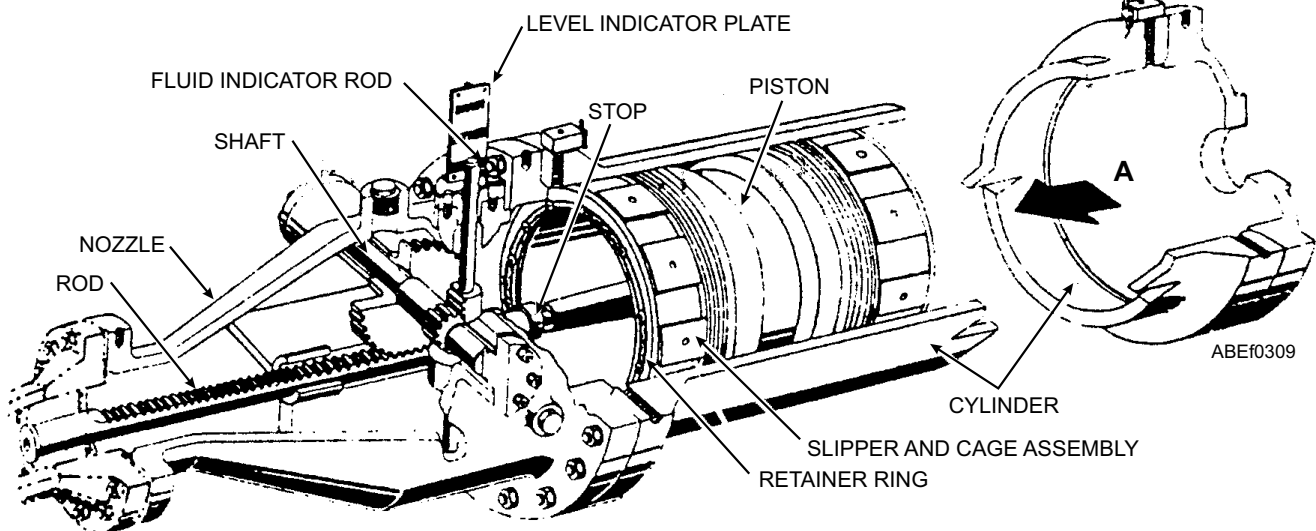

Figure 3-9.—The Mk 7 accumulator.

bolted to the air expansion flask manifold. The fluid end of the accumulator is flanged and bolted to the accumulator nozzle, which contains a fluid-level indicator, a device used to indicate to the engine-room operator whether the system has the proper amount of fluid. The fluid indicator registers the following three conditions—DRAIN (excessive amount of fluid in the system), BATTERY (proper amount of fluid in the system), and FILL (insufficient amount of fluid in the system).

The floating air-fluid separator piston is made of aluminum alloy and has two sets of V-ring packing (one for the air side and one for the fluid side), which prevent air from leaking past the piston into the fluid side of the accumulator, or fluid from leaking into the air side. Two slipper cages with phenolic slippers are fitted onto the piston to act as a bearing surface between the piston and the cylinder wall. The phenolic slippers are replaceable and must be replaced when the maximum allowable wear has been reached. This is to prevent metal-to-metal wear between the piston and the accumulator wall. An eyebolt is provided on the air side of the piston to aid in removing the piston from the accumulator when maintenance is required. The fluid side of the piston has a striker rod that actuates a fluid-level indicator located in the accumulator nozzle.

The fluid-level indicator has a drive shaft that extends through the nozzle from side to side and is secured in place by flanges and bolts. O-rings provide a seal against leakage of fluid around the drive shaft. Gears are secured onto the shaft inside the nozzle. These gears mate with teeth on the actuator rod, which extends fore and aft in the nozzle, and the fluid-indicator rod, which is vertical and extends through the top of the nozzle. An O-ring prevents leakage around the indicator rod. When the striker rod on the piston makes contact with the actuator rod, the drive shaft rotates, causing the indicator rod to move down. See figure 3-9.

An indicator plate is mounted on top of the nozzle. The plate has the readings DRAIN, BATTERY, and FILL. The indicator rod is a differential rod; and any time the piston striker rod is not in contact with the actuator rod, accumulator pressure working on the differential area of the indicator rod will cause the indicator rod to rise to the DRAIN position. The engine crosshead must always be in its BATTERY position when the fluid level of the arresting engine is checked.

FLUID REPLENISHMENT SYSTEM

LEARNING OBJECTIVE: Describe the components of the fluid replenishment system.

In any hydraulic system, small amounts of fluid are lost due to leakage. Fluid also contracts when cold and expands when hot. To compensate for leakage and expansion or contraction of the hydraulic fluid in the hydraulic system of the Mk 7 arresting engines, a fluid replenishment system is provided. See figure 3-10.

The fluid replenishment system consists of a small hand pump, mounted on the lower engine frame that is connected by piping to the engine accumulator and a 6-gallon stowage tank. If, because of leakage or fluid contraction while the engine crosshead is in BATTERY, the fluid-level indicator reads FILL, the supply valve in the piping is opened and the hand pump is operated until the indicator reads BATTERY. A fluid filter is located in the supply line to filter the fluid being pumped into the accumulator. If the fluid-level indicator reads DRAIN, the return valve located in the return line is opened, and fluid from the accumulator drains into the replenishment tank. When the fluid-level indicator reads BATTERY, the return valve is closed.

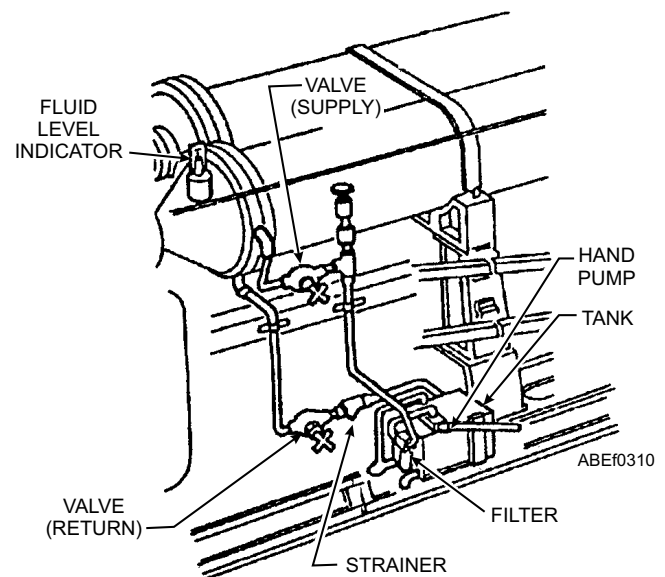

Figure 3-10.—Fluid replenishment system.

FLUID STOWAGE SYSTEM

A fluid stowage system (fig. 3-11) is provided to stow fluid from the arresting engine during maintenance and to transfer fluid back to the engine after maintenance is complete. The fluid stowage system consists of one common, steel stowage tank that serves all the arresting engines installed on a particular ship. It is equipped with piping valves from the accumulator to the stowage tank.

The capacity of the fluid stowage tanks is 700 gallons. The stowage tank is capable of storing all the fluid in the system of one arresting engine. Ship's low-pressure air is used to force the fluid to and from the stowage tank. A pressure relief valve, which is set at 120 psi, is provided to prevent excessive pressure buildup. The relief valve is located on the stowage tank. In addition, a 90-gallon stowage tank is installed on each side for the port and starboard sheave damper assemblies. The 90-gallon stowage tank is a repository to transfer and replenish hydraulic fluid for the sheave damper assemblies.

FLUID RECLAMATION SYSTEM

The fluid reclamation system (fig. 3-12) provides a means of reclaiming hydraulic fluid removed from any engine due to venting or through leaks or spills. The

fluid reclamation system consists of a stainless steel 90-gallon tank located in close proximity to the fluid stowage tank, a centrifugal 1/3 hp pump, filter and piping connections. The piping connects the reclamation tank to the existing stowage tank line. During fluid transfer from the reclamation system, hydraulic fluid is filtered to ensure that only clean uncontaminated fluid enters the fluid stowage tank.

FLUID COOLER

During continuous arresting operations, the engine fluid temperature rises because of friction of the fluid moving through the engine, control valve, and piping. To maintain extended pendant engine operation, the fluid temperature is reduced by the fluid cooler. (See fig. 3-13.) The maximum operating temperature for the arresting engines is 170°F. Prolonged operation at this temperature limit is not recommended.

The fluid cooler is mounted in saddles on top of the engine structure adjacent to the accumulator.

Fluid coolers are used on all Mk 7 arresting engines serving a pendant engine. Engine fluid, as it is returned from the accumulator to the main engine cylinder during retraction of the engine, flows through the fluid cooler body. Heat from the engine fluid is transferred to cool service water (salt water) flowing at 100 gallons per minute through tubes within the cooler body.

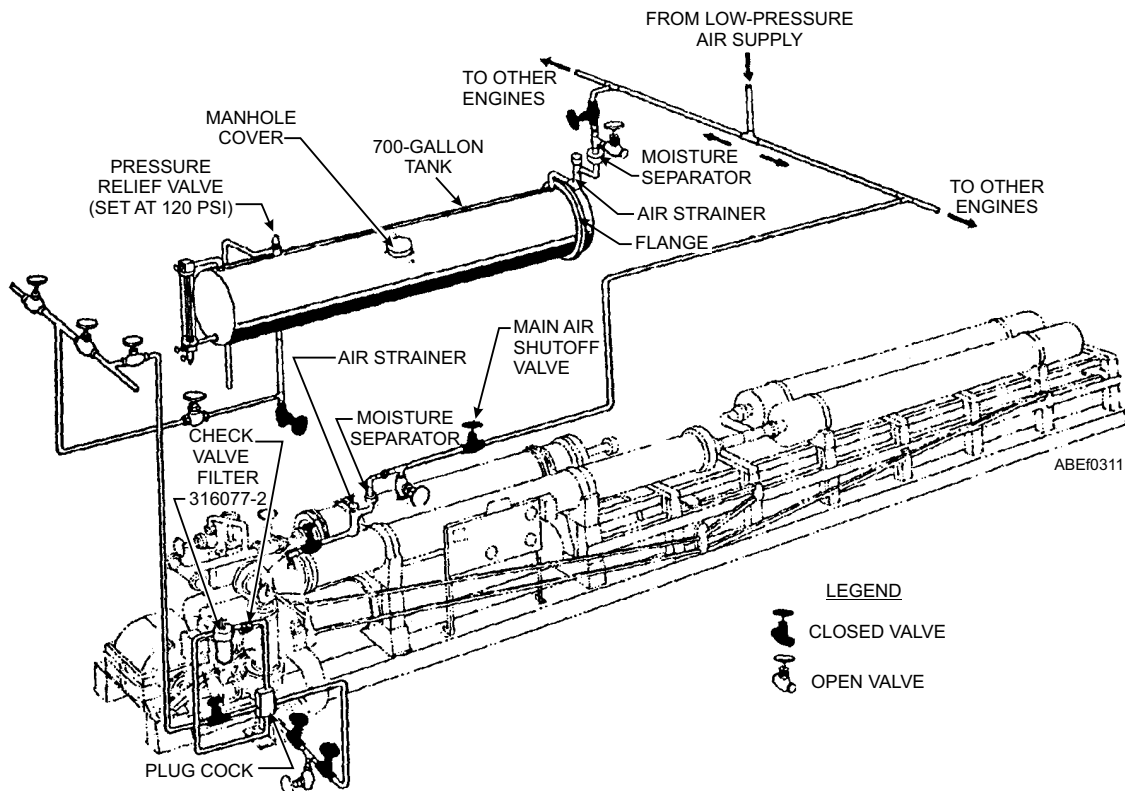
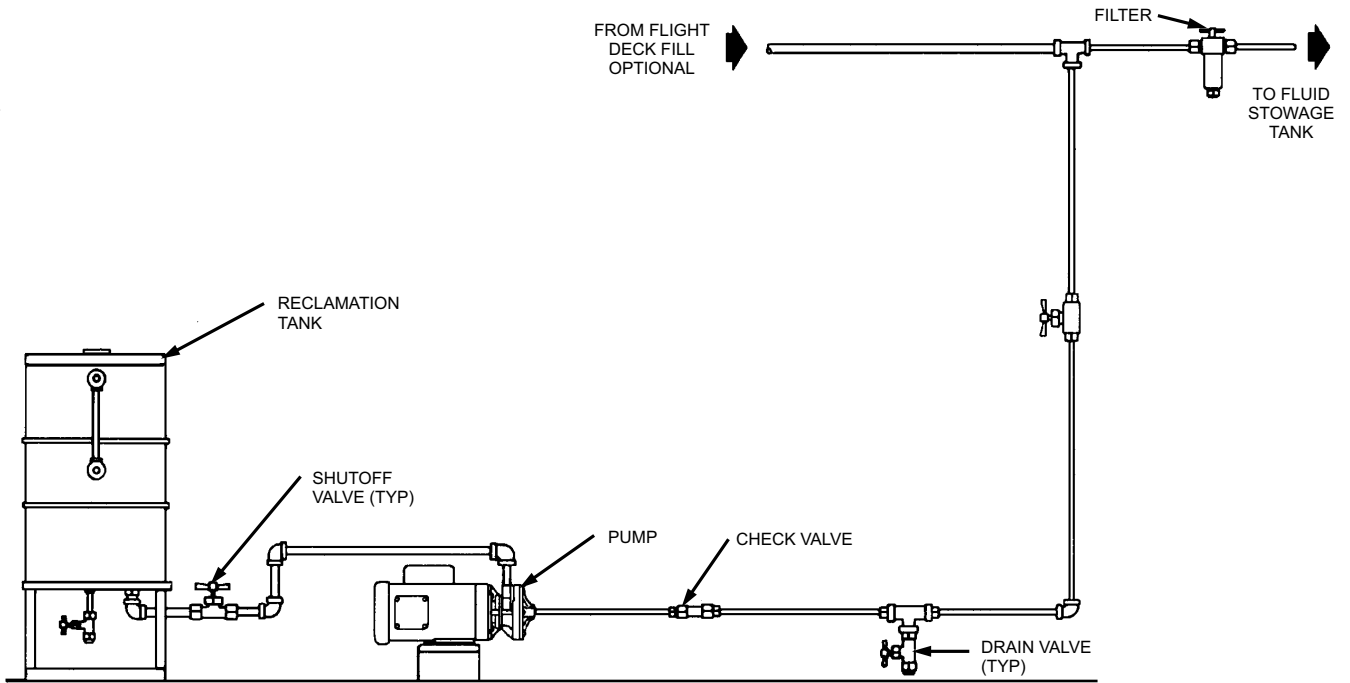
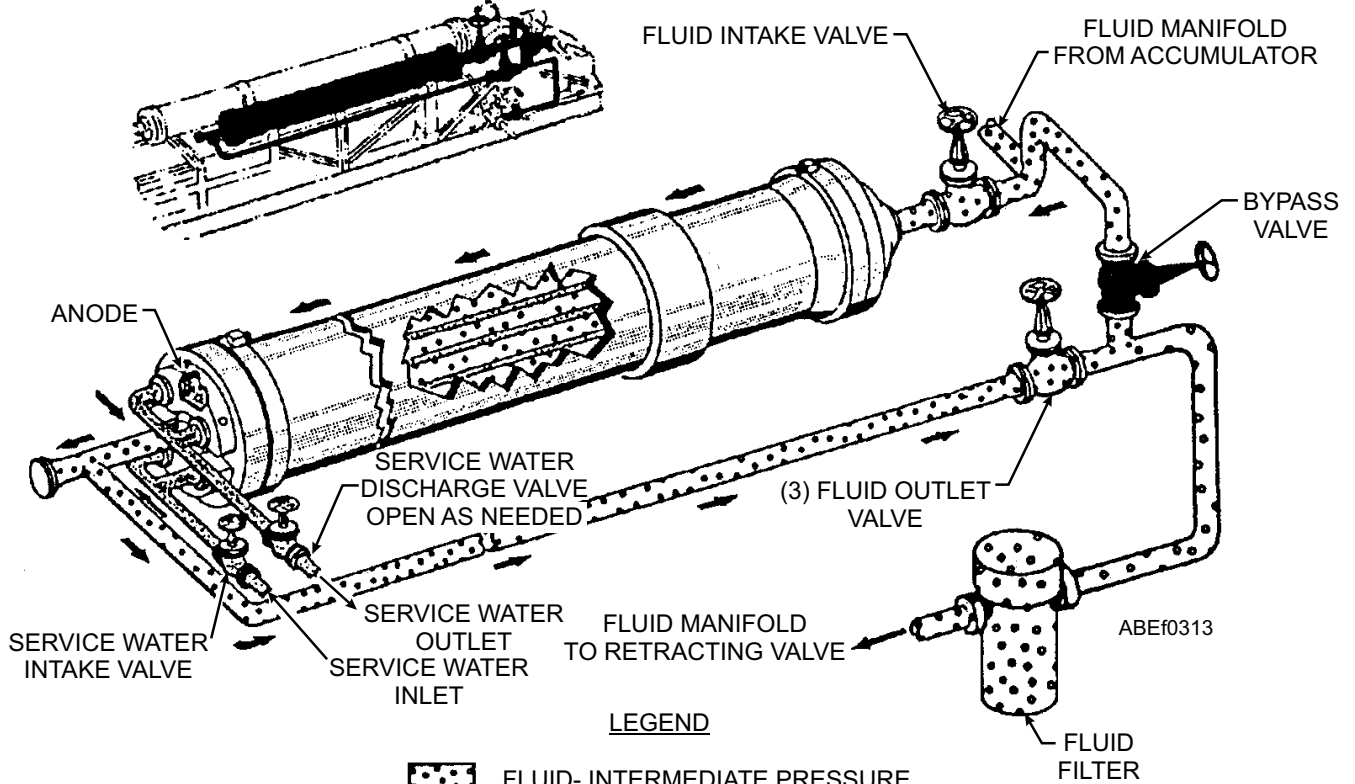

Figure 3-11.—Fluid stowage system—secured condition.



ABE0312

Figure 3-12.—Fluid reclamation system



ABE0313

Figure 3-13.—Fluid cooler assembly.

The fluid cooler body is a cylindrical steel shell with two flanged ends. The body of the cooler has four equally spaced holes in each end to provide a means of draining and venting the cooler. These holes are normally closed with pipe plugs or vent valves. One end of the cooler has a cooler head assembly that forms a cap for one end of the body and provides an inlet for engine fluid coming from the accumulator. The cooler head assembly is a disc-shaped steel casting with an opening in the center, which is flanged to the fluid inlet piping.

A copper annealed gasket is used as a seal between the cooler head and the body to prevent fluid leakage. The head is bolted to the body. The coolant (salt-water) flows through a tube assembly that consists of 107 U-shaped copper tubes supported inside the cooler body by three circular baffle plates. A tube head is bolted to the end of the cooler, opposite of the cooler head. A copper annealed gasket is used as a seal against fluid leakage between the tube head and the cooler body. Cooled fluid passes through the center of the tube head, through piping, to the retract valve. Two kidney-shaped manifolds (one inlet and one outlet manifold for the coolant to flow) are bolted to the outer face of the tube head.

Saltwater piping leading to and from the inlet and outlet manifolds has shutoff valves, one intake and one

discharge, that are used to throttle the flow of salt water and maintain the desired fluid temperature. Shutoff valves are also provided in the fluid inlet and outlet lines to provide a means of isolating the fluid cooler in the event of cooler leakage, and a bypass valve is provided to direct the fluid from the accumulator to the retract valve when the cooler is isolated. To prevent corrosion within the cooler, replaceable anodes are installed at both the saltwater inlet and outlet manifolds. These anodes are periodically inspected and replaced according to the applicable maintenance requirement card (MRC). A fluid temperature indicator is located on the engine control panel.

AUXILIARY AIR FLASKS

The auxiliary air flask provides a means of storing ship's air at 3,000 psi. In the event of a ship's air system failure, the air stored in the auxiliary air flask can be used to recharge the arresting engine.

The air flask is a cylindrical container with hemispherical ends. One end of the air flask is provided with a pipe tap for connecting an air line, which is used for charging and venting. A drainage vent is located on the underside of the air flask to drain condensate water.

Air can be supplied to the air unit of the arresting engine from the auxiliary air flask by use of the charging valve mounted on the main control panel.

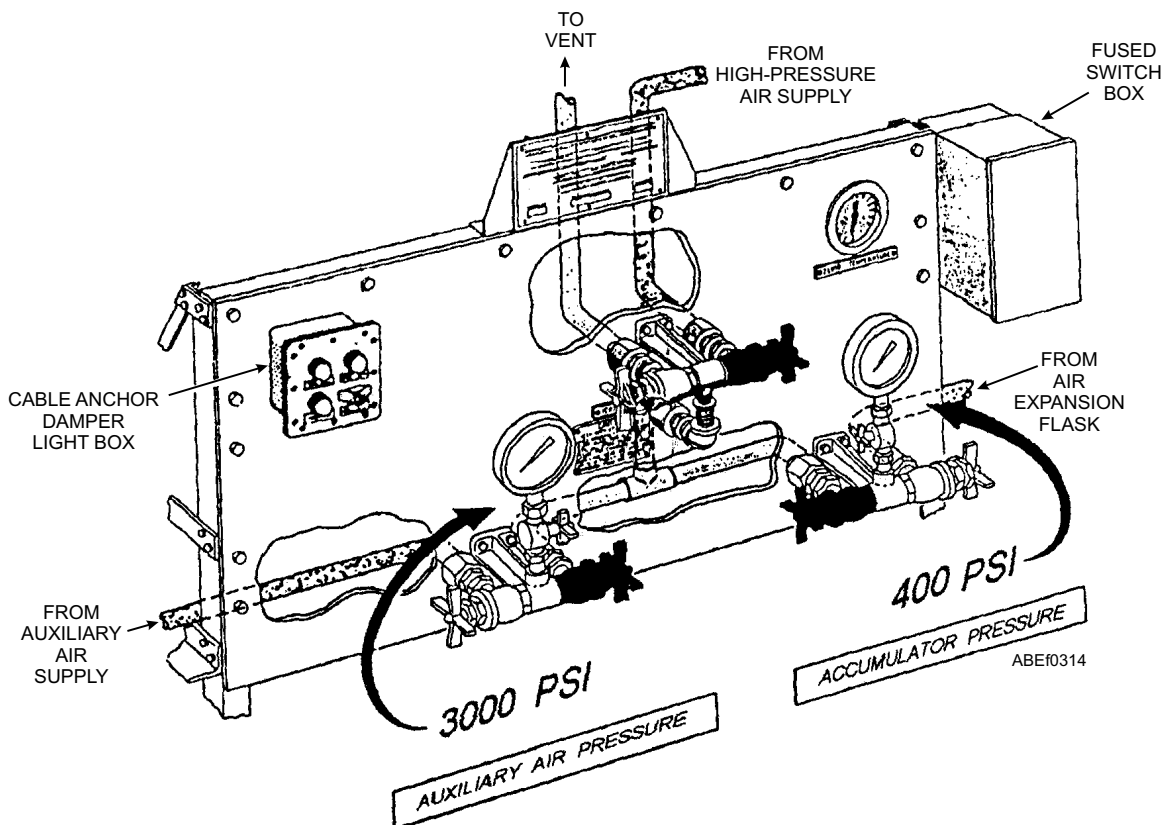

Figure 3-14.—Engine control panel.

MAIN CONTROL PANEL

The control panel is the control center for the arresting engine. (See fig. 3-14.) It provides a means for the operator to centrally regulate the air pressure in the system, keep a check on the fluid temperature, and energize the electrical system. The control panel is also equipped with a cable anchor damper light box.

The control panel is a rectangular sheet of steel mounted on the engine structure on the CRO-valve side of the engine.

Three air manifolds are located on the control panel: a main air-charging manifold with high-pressure air piping leading from the ship's high-pressure air supply system; an air manifold for the auxiliary air flasks; and a manifold for the accumulator. The main air-charging manifold is equipped with an air-charging valve, which is closed except when taking on air from the ship's high-pressure air supply system to charge the auxiliary air flasks and accumulator.

High-pressure air piping is provided from the main air-charging manifold to the auxiliary air flask manifold and the accumulator manifold. The auxiliary air flask and accumulator manifolds each have

air-charging valves, gauge valves, and a pressure gauge. The auxiliary air flask charging valve allows for charging the auxiliary air flasks or emergency charging of the accumulator from the air flasks. The auxiliary air flask pressure gauge monitors the air pressure of the auxiliary air flasks. The accumulator charging valve allows for charging of the accumulator and air expansion flask. The accumulator pressure gauge monitors the air pressure of the accumulator and air expansion flask.

A fuse switch box is mounted at the end of the control panel and contains the main switches for activating the electrical system of the arresting gear.

The cable anchor damper battery position indicator light box on the control panel contains a power ON and OFF switch and three indicator lights. A white light indicates the power switch is on. Two green lights give battery position indication of the cable anchor dampers.

CYLINDER AND RAM ASSEMBLIES

The cylinder acts as a receiver for the ram and as a reservoir for the fluid to be displaced by the ram. Figure 3-15 illustrates the cylinder and ram assembly of the Mod 3 arresting engine.

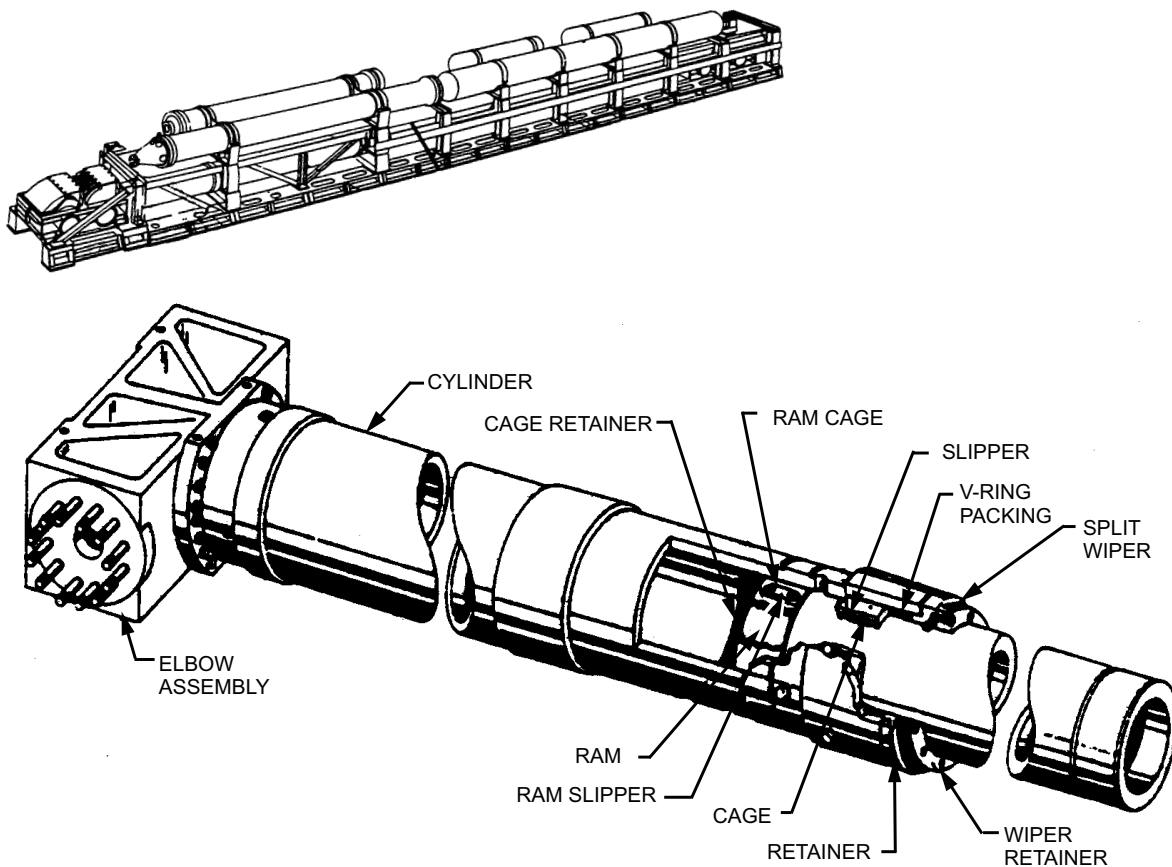

ABE0315

Figure 3-15.—Cylinder and ram assembly.

The cylinder and ram assembly constitutes the actual engine of the arresting gear. It is located within the engine structure between the movable crosshead and the cylinder outlet elbow on the engines.

The cylinder is a machined, forged steel, smooth-bore tube, open on both ends and large enough to provide a working area for the ram and to house the fluid necessary for aircraft arrestments. It is supported within the engine structure by cylinder support saddles. One end of the cylinder is clamped and bolted with four cylinder clamps and Allen bolts to the cylinder outlet elbow. The other end receives the ram

The ram is a large, hollow steel piston that is moved in and out of the cylinder by the crosshead. It is bored to reduce the weight, although it is not bored completely through. The inner end (the end that fits in the mouth of the cylinder) is solid and provides a working area between the ram and engine fluid during arrestments.

The inner end of the ram contains a set of V-ring packing to provide a seal for the engine fluid between the cylinder wall and the ram also the inner end of the ram is stepped to accommodate a cage and slippers, which provide a bearing surface for the ram as it slides in and out of the cylinder.

The outer (open) end of the hollow steel ram is clamped into a socket on the crosshead by a split flange, which fits into an annular groove near the end of the ram.

CROSSHEAD AND FIXED SHEAVE INSTALLATION

The principle involved in the operation of the crosshead and fixed sheaves is that of a block and tackle. The purchase cables are reeved around the sheaves of the crosshead and fixed sheave assemblies. The crosshead is a three-piece welded structure with two hollow steel shafts clamped between its outer sections and the center section. The crosshead body is clamped to the outer end of the ram by a split flange, which fits into an annular groove around the end of the ram. Figure 3-16 illustrates the crosshead.

The crosshead contains two similar banks of sheaves, with nine sheaves in each bank. The sheaves located outboard on the crosshead are 33-inch pitch diameter, and the sheaves located on the inboard shaft are 28-inch pitch diameter. The difference in the pitch diameter of the two banks of sheaves is necessary so that the purchase cable reeved around the outboard

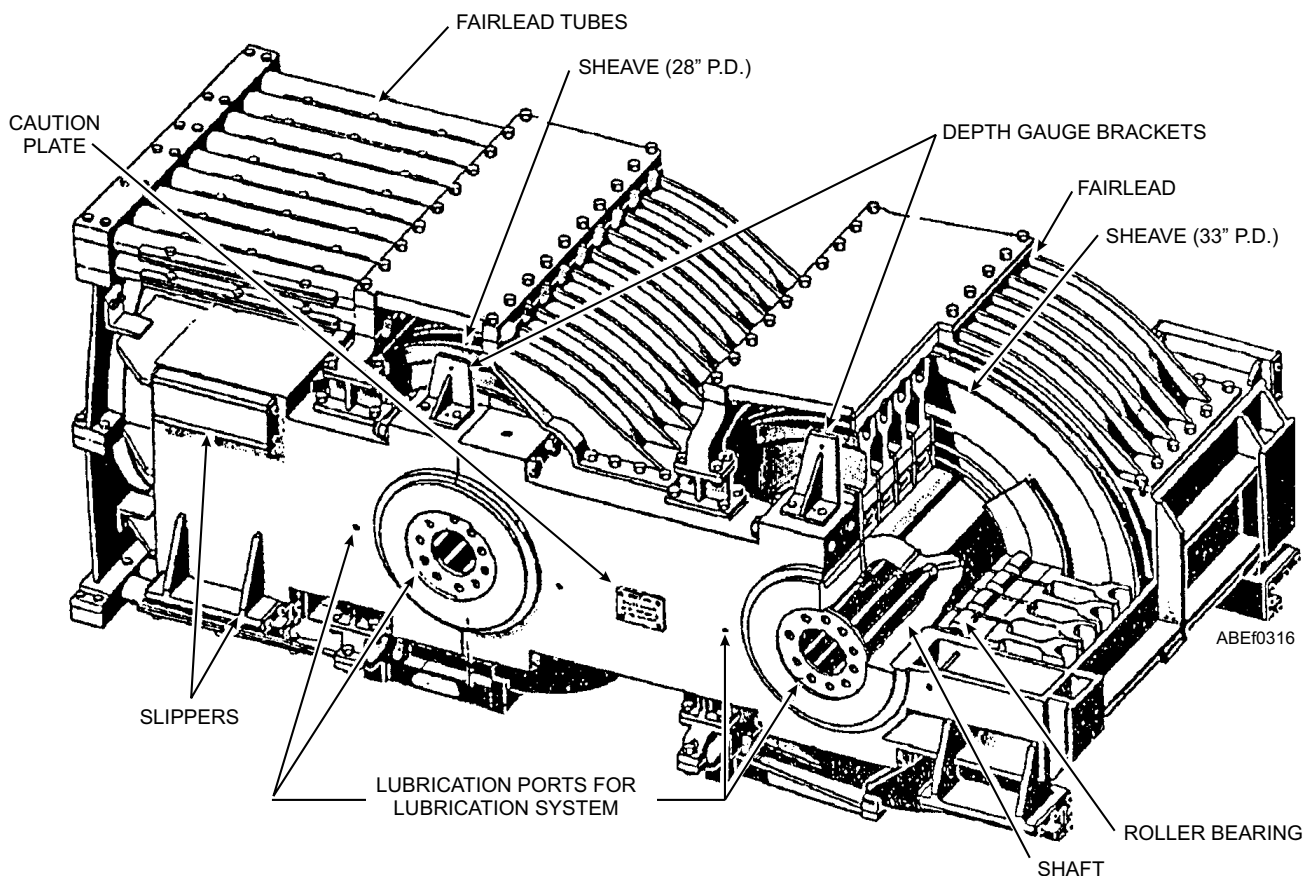

Figure 3-16.—Crosshead assembly.

(33-inch pitch diameter) sheaves will clear the inboard (28-inch pitch diameter) sheaves.

The crosshead sheaves are made of an aluminum alloy casting and have three sections: an inner race, a cage and roller assembly, and an outer race. All the sheaves in the crosshead and the fixed sheave installation rotate on roller bearings with the exception of the 28-inch pitch diameter high-speed sheave that fairleads the purchase cable from the engine to the flight deck. This sheave rotates on a ball thrust bearing. The sheaves are separated by two-section concentric disc spacers. Each spacer has an inner and an outer disc. The inner disc is made of steel and provides lubrication channels from the shaft to each cage roller assembly. The outer disc is made of phenolic and acts as a bearing surface for the outer sheave race; it also retains the grease.

Phenolic spacers are bonded to the sheaves on the high-speed side only. The low-speed side has loose

phenolic spacers. The sheaves are lubricated through 10 zerk fittings located on the end of each of the two hollow steel shafts (20 zerks total).

The crosshead is provided with slipper liners as a bearing surface between the crosshead and the crosshead tracks. There is a total of 16 slipper liners—2 on each side at the top, to prevent side thrust, and 3 on each corner at the bottom, for a bearing surface. Brass retainers hold the slipper liners in place.

The fixed sheave assembly is identical in construction to the crosshead, and all movable parts are interchangeable. The fixed sheave assembly acts as the stationary half of the reeve system and therefore does not require liners. See figure 3-17.

AUTOMATIC LUBRICATION SYSTEM

LEARNING OBJECTIVE: Describe the automatic lubrication system.

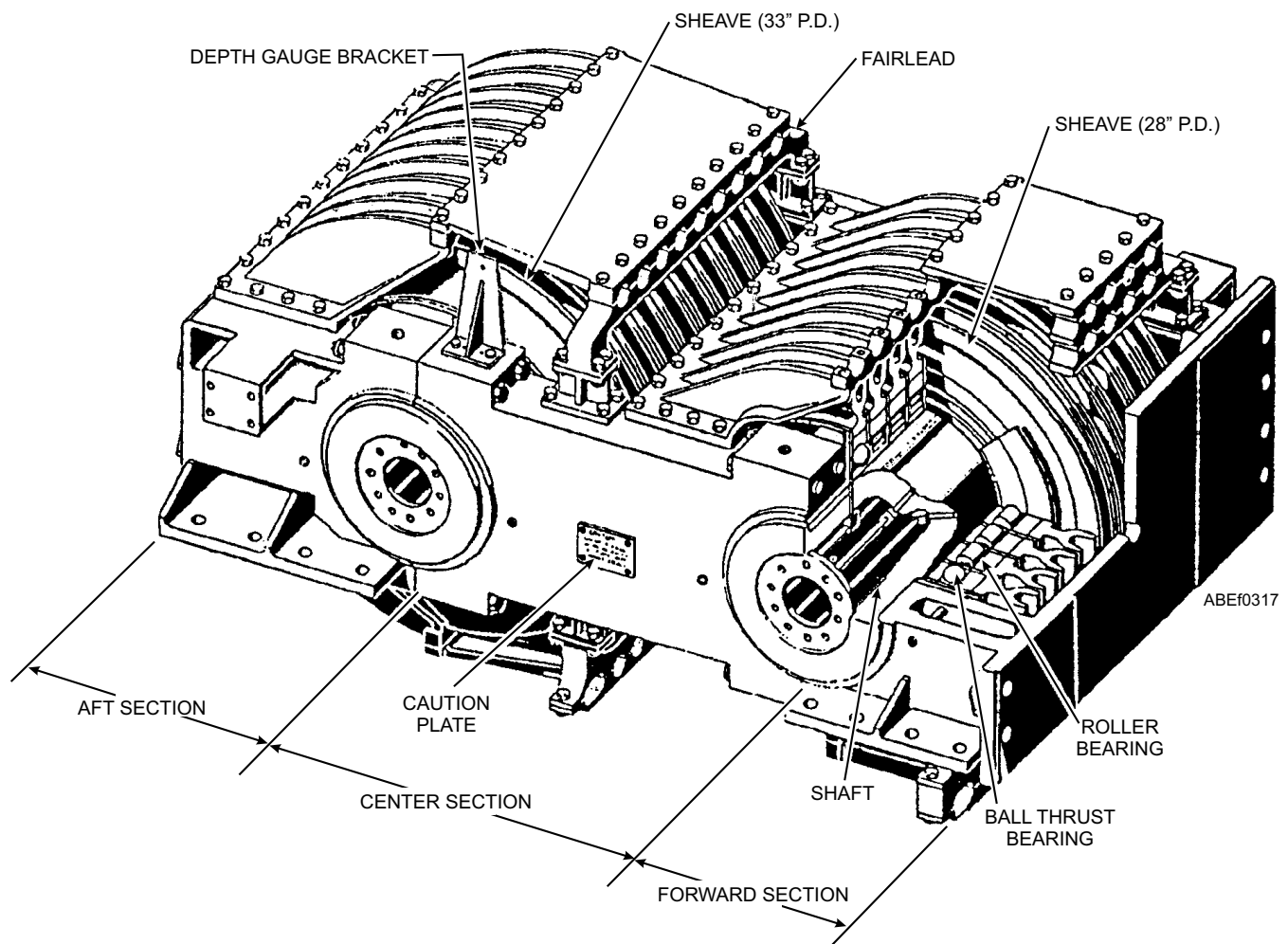

Figure 3-17.—Fixed sheave assembly.

An automatic lubrication system (fig. 3-18) ensures that lubricant is automatically provided to the arresting engine crosshead and fixed sheave assembly during arrestment operations (pendant engines only). The ship's low-pressure air, is piped to a regulator, which reduces the air to the required operating pressure of between 75 and 85 psi. Air is fed through a rubber hose to a pump mounted on top of a 120-pound drum of lubricant. Lubricant is pumped from the drum through hoses to control valves mounted on the engine structure. These control valves adjust the rate of flow of lubricant to the high-speed sheaves.

The control valves are operated by plunger rollers, which are cam-actuated at a set position of the engine crosshead arrestment stroke. An ounce of lubricant is pumped to the high-speed sheaves during the arrestment and the retraction cycles. A hose reel with a flexible rubber hose is mounted on the crosshead end of the engine structure, with the hose connected to metal tubing on the engine crosshead. As the crosshead moves toward the fixed sheaves during arrestment, the hose pays out and spring tension in the hose reel takes

up the hose during retraction. The spring tension on the hose reel must be 9 pounds ($\pm 1/2$ pound), with the hose fully retracted, at all times.

The automatic lubrication controller (fig. 3-19) allows the engine room operator to set both a pulse counter and a timer unit which deliver a predetermined amount of lubricant to every lubrication point. The controller signals when the system is ready, when it is operation or when a malfunction occurs. The controller can be operated manually to initiate a lubrication cycle without movement of the crosshead and cal reset itself after a malfunction has been corrected in the lubrication system.

The 28-inch pitch diameter sheave containing the ball thrust bearing is not lubricated with the automatic lubricating system. The ball thrust bearing eliminates the need for constant lubrication. Lubricating the ball thrust bearing sheave is accomplished with a manually operated grease gun after every 20 to 30 arrestments. (See fig. 3-18 for an illustration of the automatic lubrication system.)

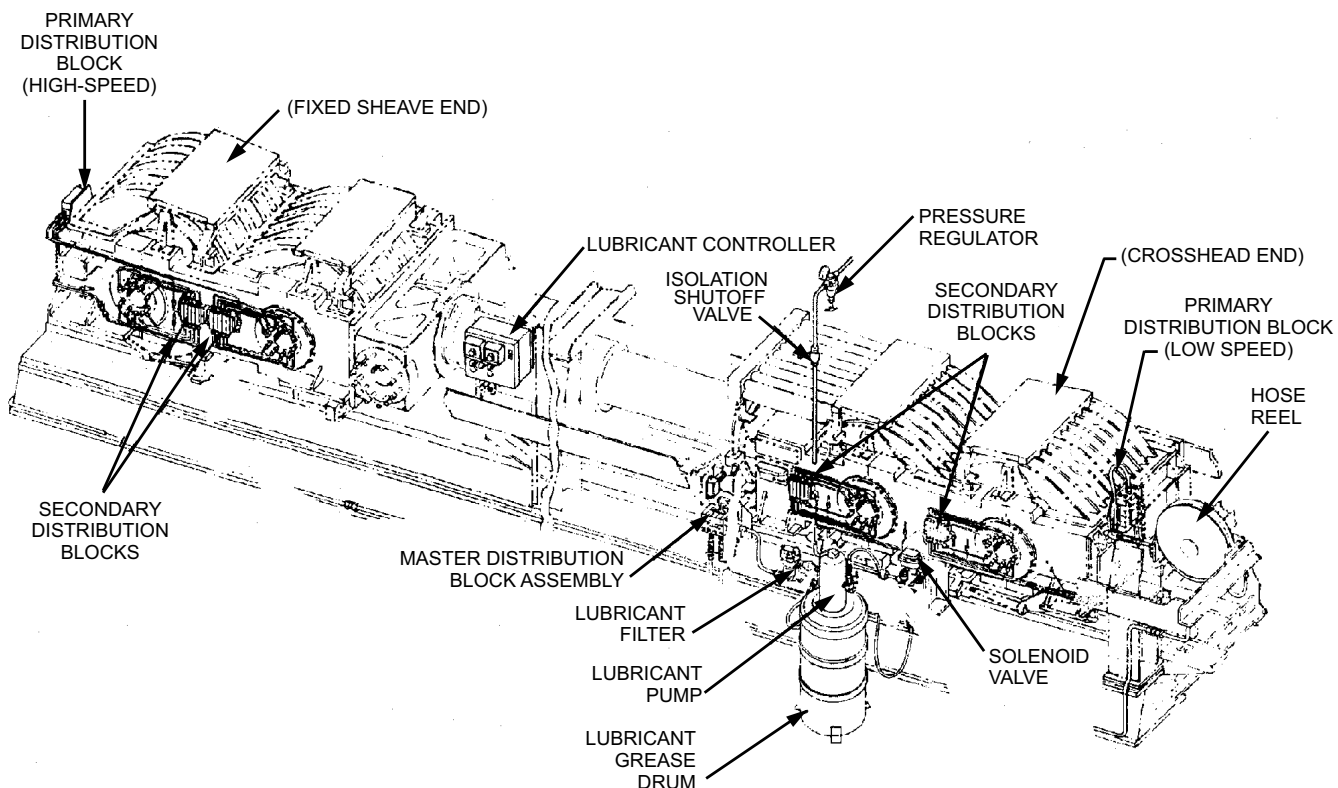

ABEf0318

Figure 3-18.—Automatic lubrication system.

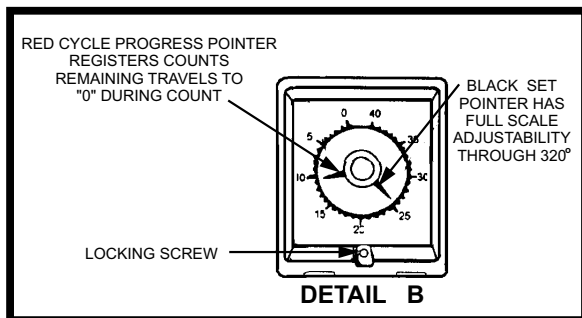
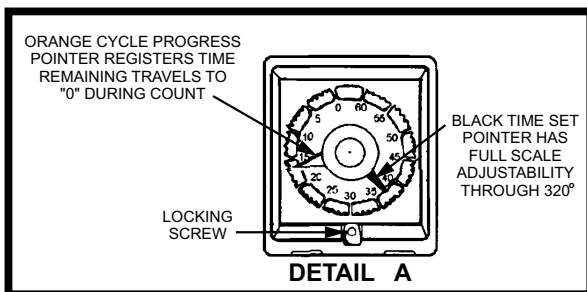
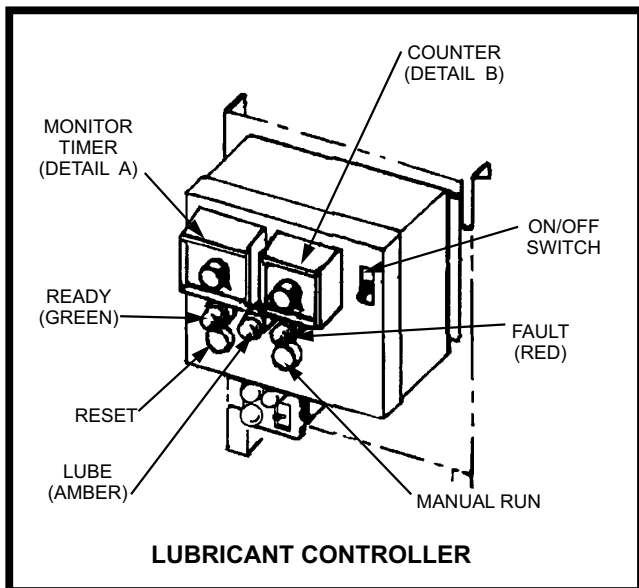

ABEF0319

Figure 3-19.—Automatic lubrication controller.

CABLE ANCHOR DAMPER

LEARNING OBJECTIVE: Describe the components of the cable anchor damper.

The cable anchor damper installation consists of two identical anchor damper assemblies. In most cases one cable anchor damper assembly is deck mounted

and the second assembly is overhead mounted (fig. 3-20). Compartment configuration determines how the units are installed.

The purpose of the cable anchor damper is to eliminate excessive purchase cable slack between the crosshead and fixed sheave assembly at the beginning of the arrestment stroke. Through service use and experimental testing, it was found that when this cable slack was taken up by the landing aircraft, excessive vibrations occurred in the engines. The cable anchor damper removes this slack as it occurs, thereby eliminating vibration of the purchase cable. The cable anchor damper assembly is used with pendant engines only.

Referring to figure 3-20, note that each cable anchor damper assembly includes a cylinder that connects to an operating end head and a cushioning end head. Piping connects the engine cylinder to the operating end head through a manifold tee. Two lines branch from the manifold tee, one to each damper assembly operating head. Each of these lines contains a flow control valve. A cover is placed over the operating piston rod and coupling assembly for safety of operation and protection against foreign matter. Each damper assembly is mounted on a base before installation.

A battery positioner, actuated by the retracting lever, is provided to ensure the return of the damper assembly to the BATTERY position after an arrestment. A battery-position indicator is provided to indicate when the cable anchor damper is in the BATTERY position, ready for aircraft engagement. The limit switch and cam actuator for the battery-position indicator are located on the cable anchor damper assembly, and the indicator lights are located on the arresting engine control panel.

The end of the purchase cable is attached to the operating end piston rod by an anchor damper coupling. When the force on the operating piston, due to engine cylinder pressure, is greater than the tensile force in the purchase cable, the piston moves away from its BATTERY position. Movement of the operating piston into the cylinder removes the cable slack during the first portion of the arrestment. When the slack is taken up, the operating piston resists the return of the cable, thus keeping it taut and preventing excessive cable vibration.

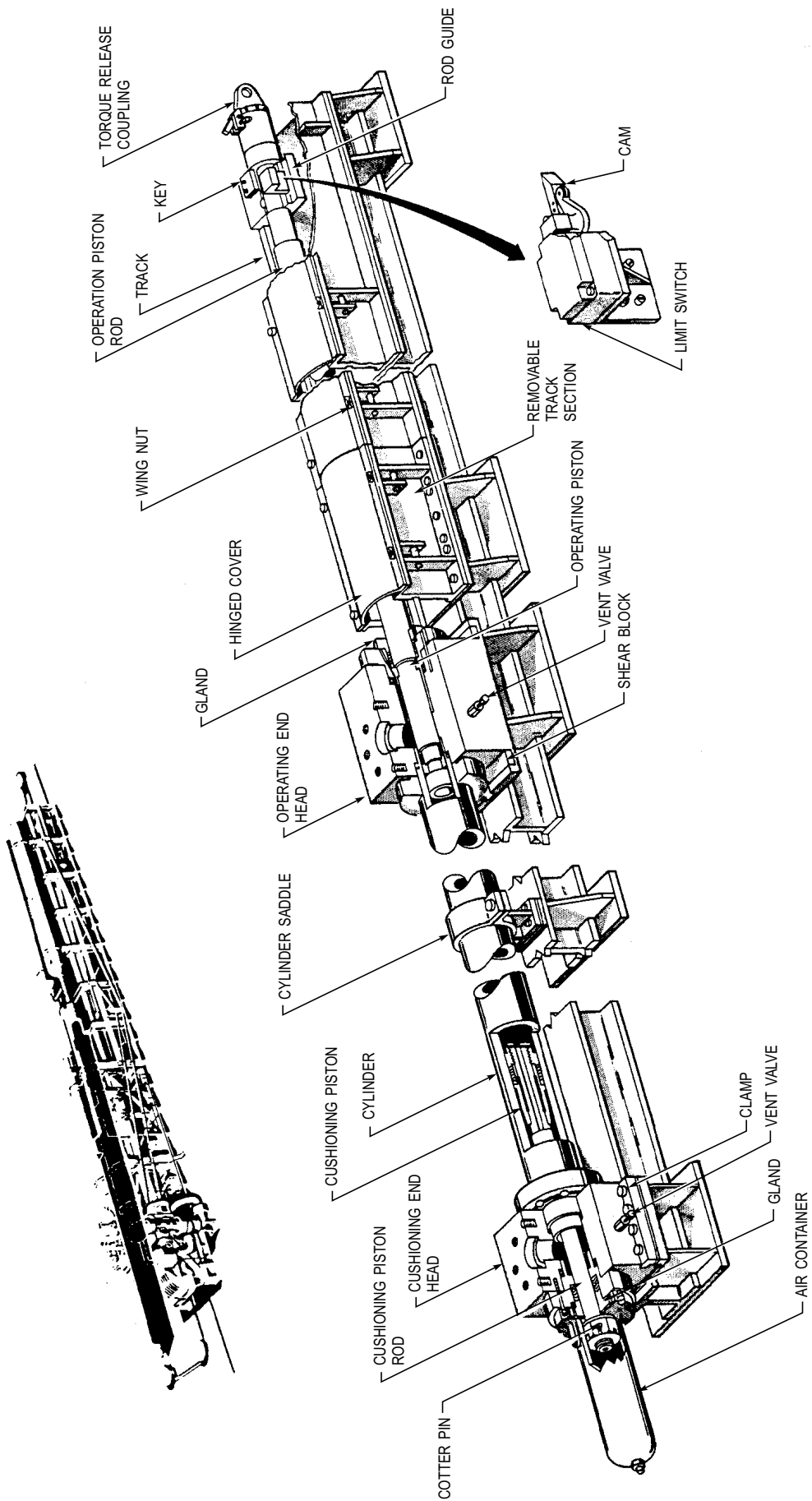

Figure 3-20.—Cable anchor damper installation.

ABE0320

Upon engagement of the deck pendant by the aircraft, the engine crosshead is accelerated toward the fixed sheaves. This movement forces the ram into the arresting engine cylinder, increasing the fluid pressure in both the engine cylinder and the operating head of each cable anchor damper. See figure 3-21.

Because of the acceleration rate of the engine crosshead, the tension in the purchase cable (2) between the engine sheaves and the cable anchor dampers decreases momentarily. The instant the tensile force in the cable becomes less than the force on the operating piston (4), fluid pressure moves the operating piston away from its BATTERY position until all slack is removed and the cable tension is again greater than the fluid pressure force acting on the operating piston.

The flow control valve is a clapper-type check valve that allows free flow of the fluid one way and a restricted flow in the opposite direction. The engine fluid has free flow through the flow control valve (1) to

the operating end of each cable anchor damper. When the tension of the purchase cable is transmitted to the cable anchor ends, the fluid pressure on the operating pistons is overcome by this cable tension, and the operating pistons are pulled back toward BATTERY position. Resistance to their return is furnished by the engine fluid pressure and the controlled flow of fluid through the flow control valves back to the engine cylinder.

CUSHIONING PISTON

The sole function of the cushioning piston is to prevent the operating piston from slamming into the opposite end of the cable anchor damper assembly if the purchase cable should break or in the event of an extreme off-center landing. In either situation, the operating piston accelerates away from its BATTERY position and rams the cushioning piston.

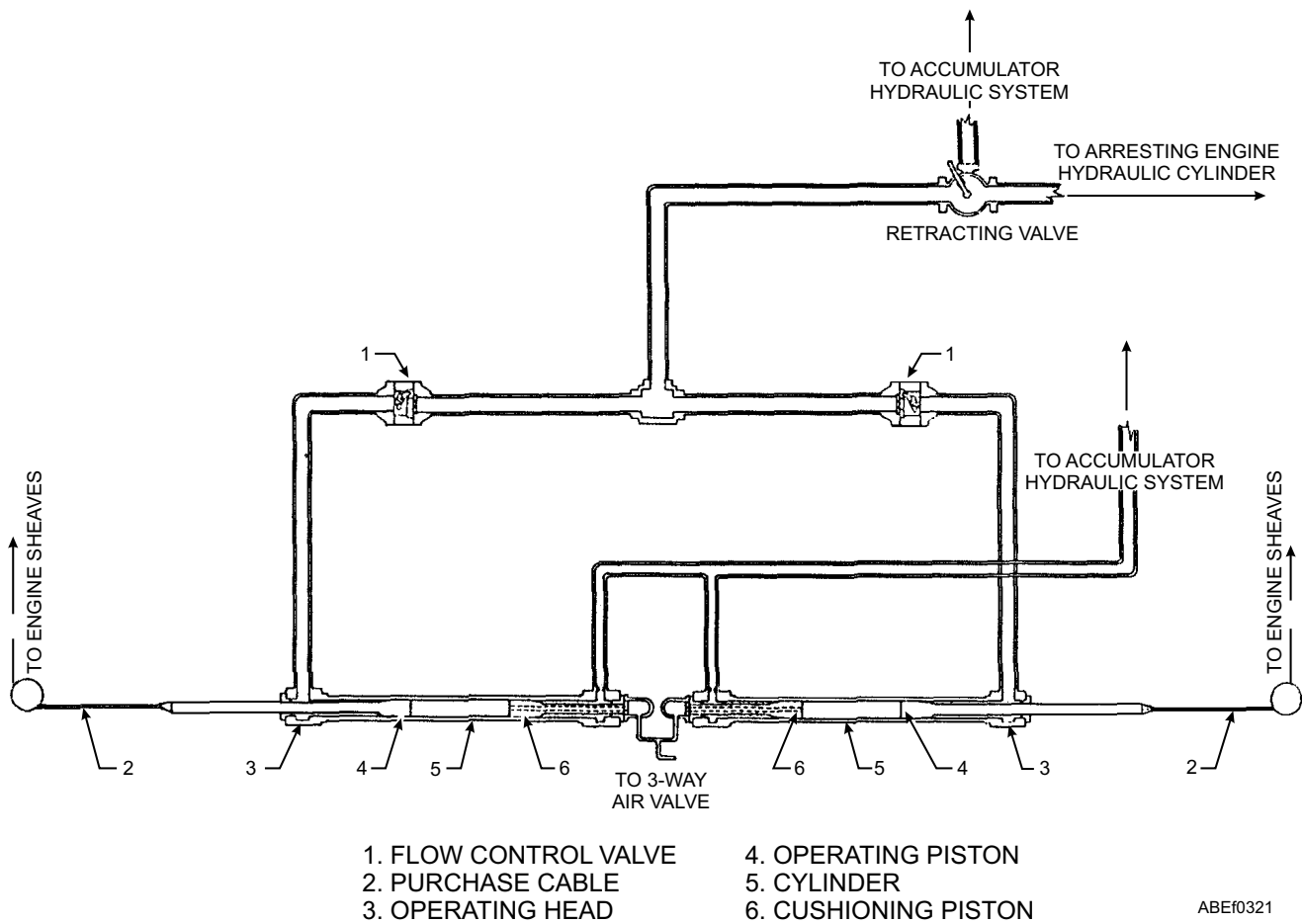

Figure 3-21.—Cable anchor damper fluid flow (arrestment).

BATTERY POSITIONER

The battery positioner (fig. 3-22) functions to return the cable anchor damper piston to its BATTERY position during the retracting cycle of the arresting engine.

The battery positioner includes a three-way air valve (3), which is connected to a 100-psi air supply and to the air container mounted on the cushioning end of each damper assembly. An air strainer (4) is located in the supply line ahead of the three-way valve. The three-way air valve is mounted on a base plate (5), secured to the arresting engine retracting valve, and operated by means of a cam (1) mounted on the retracting valve actuating lever.

When the actuating lever is moved to its retract position, the cam positions the three-way air valve to admit 100-psi air to the air containers. From the air container, the 100-psi air passes through a hole in the cushioning piston rod and acts against the operating piston, moving it to its fully retracted position. As soon as the actuating lever is released, the air pressure is shut off, and the air container is vented through an exhaust line (2) at the three-way air valve. A line containing a liquid sight indicator (7) and a drain plug (6) is provided at each container. The fluid sight indicator permits detection of fluid leakage into the air container.

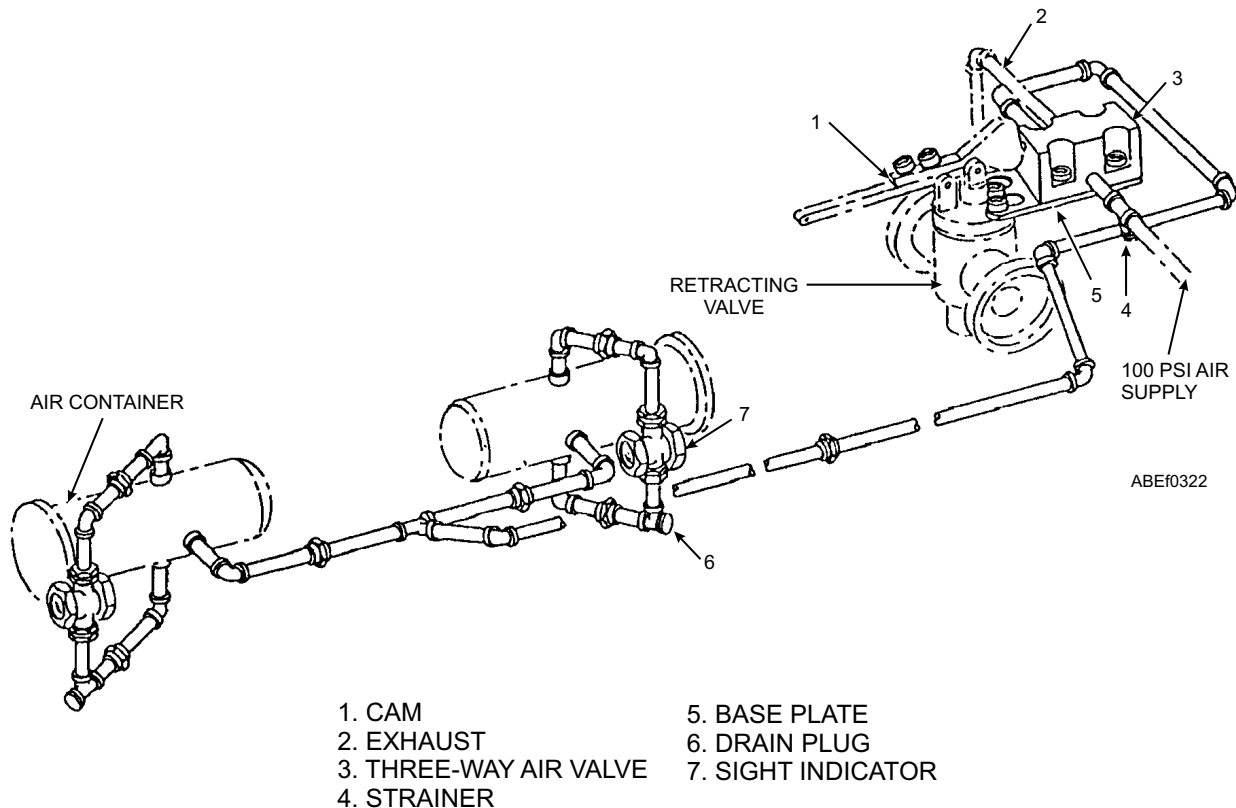

Figure 3-22.—Battery positioner.

ARRESTING ENGINE DRIVE SYSTEM

LEARNING OBJECTIVE: Describe the components of the arresting engine drive system.

The function of the drive system is to provide a means of transferring energy from an arresting aircraft to the arresting engine components that provide the means of dissipating and absorbing that energy. The drive system consists essentially of sheave damper, purchase cable, fairlead and deck sheaves, crossdeck pendants, and wire supports (fig. 3-23).

SHEAVE DAMPER

Because of the high engaging velocities of modern carrier-based aircraft, cable tension and vibration would be excessive unless eased by the shock absorption provided by the sheave damper. The sheave damper reduces peak cable tension and lessens cable vibration.

In figure 3-24, a sheave damper assembly is mounted to the ship's structure below each port and starboard retractable or fixed horizontal deck sheave. The port and starboard assemblies are identical; therefore, only one will be discussed.

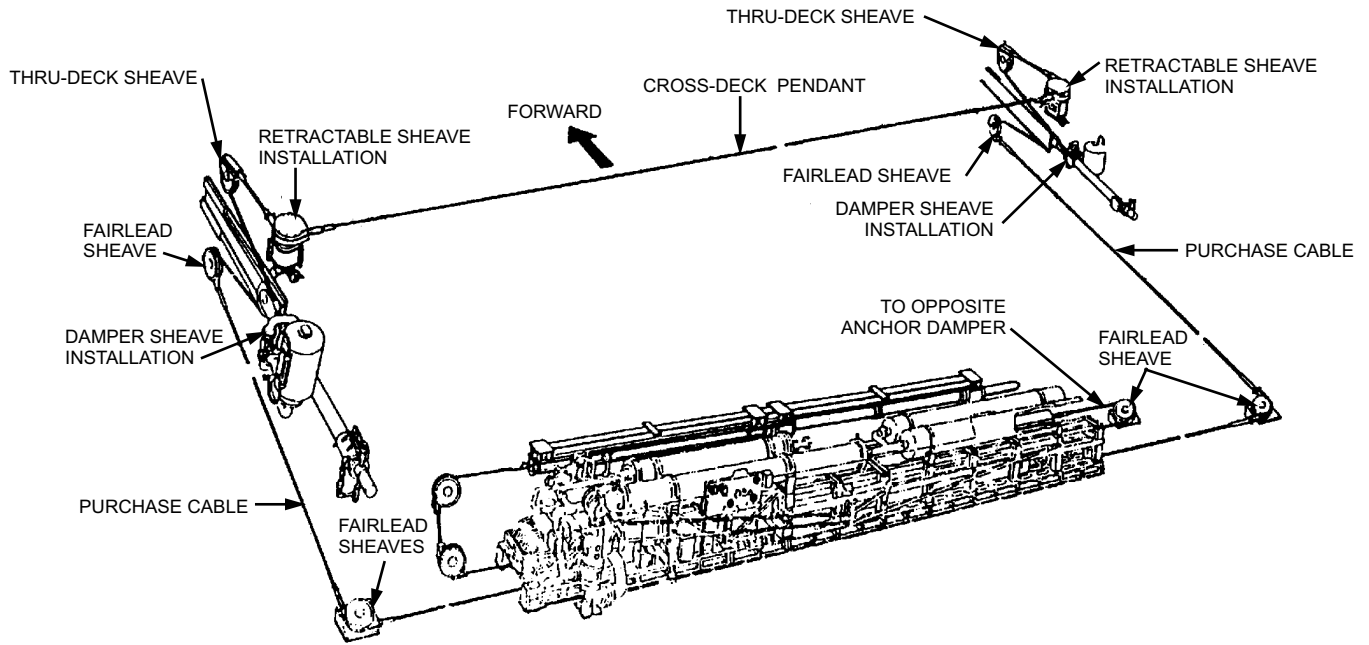

ABEf0323

Figure 3-23.—Arresting engine drive system.

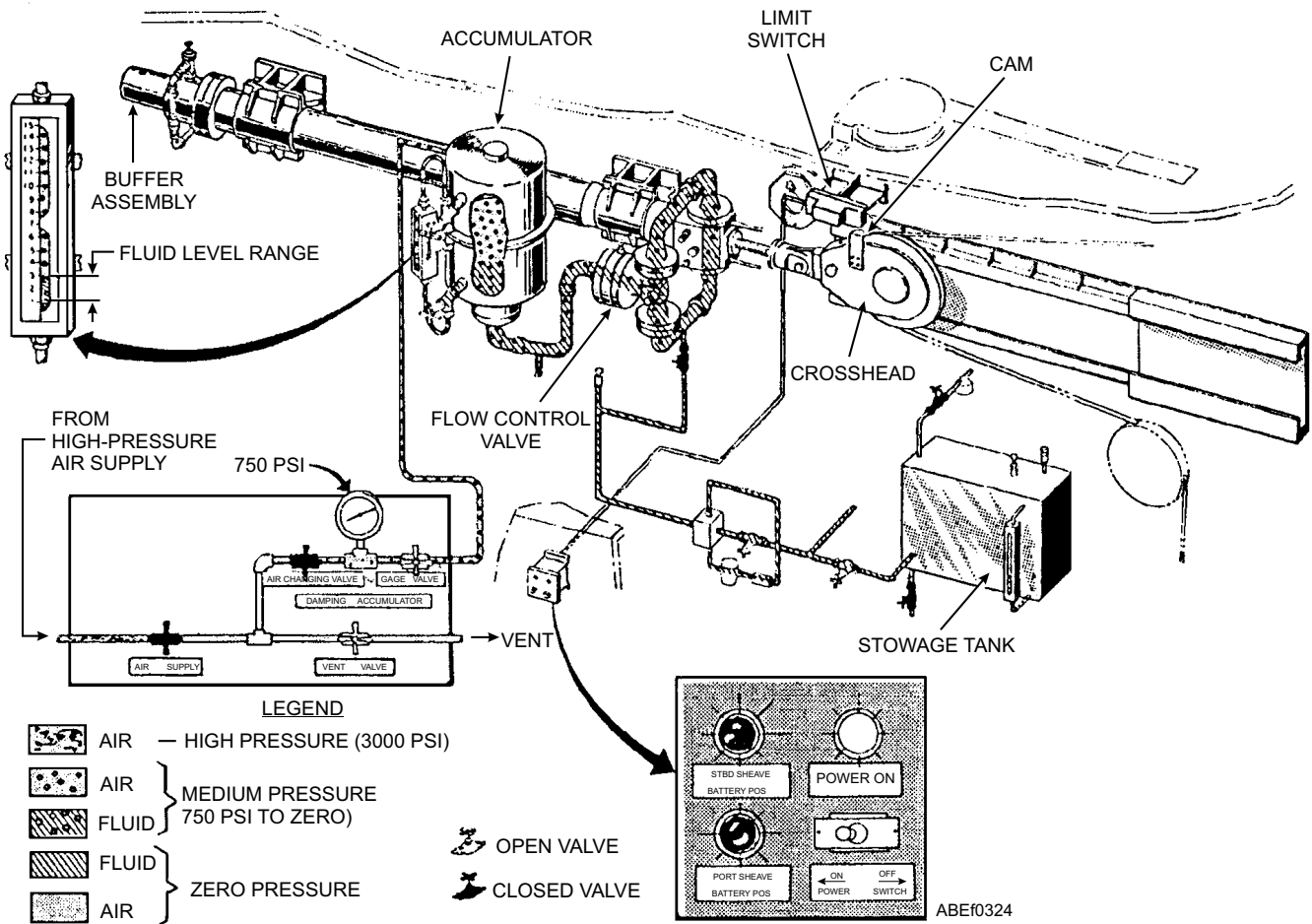

ABEf0324

Figure 3-24.—Sheave damper installation.

Description

Each sheave damper assembly consists of a movable crosshead assembly, damper cylinder assembly, damper piston, damper accumulator and fluid piping, buffer assembly, and charging panel. The system is also equipped with a common fluid stowage tank, which provides a stowage space for fluid in the sheave damper assembly while maintenance is being performed. The tank is capable of stowing all the fluid in one sheave damper installation.

The crosshead assembly consists of one roller bearing sheave mounted between a steel base plate and a side plate that are bolted together. A sheave shaft, mounted through the bottom of the base plate, is secured to the side plate by a cap and setscrew. A yoke is bolted between the side plate and the base plate and provides a means of connecting the crosshead to a clevis that is screwed onto the end of a piston rod. The crosshead rides in a track mounted in a horizontal position on the bulkhead.

Phenolic slippers, at all four corners of the base plate, provide a bearing surface between the crosshead and the track. Attached to the crosshead is a cam that actuates a limit switch when the crosshead is fully retracted and causes a green light to light at the deckedge control station. This indicates to the deckedge operator that the sheave damper is in its BATTERY position.

The damper cylinder assembly is secured to the ship's structure by brackets, which are welded to the bulkhead and bolted to the cylinder. A cylinder cap is screwed onto the crosshead end of the cylinder and held in place by setscrews. The cap provides a fluid passage between the cylinder and the fluid manifold piping leading to the damper accumulator. The damper piston rod extends through the cap at the crosshead end of the cylinder. The damper piston is secured onto the opposite end of the piston rod and held in place by a castle nut and cotter pin.

The fluid manifold is bolted to the top and bottom of the cylinder cap. A reducing tee connects the upper and lower manifold piping and serves to divert fluid flow from the accumulator equally into the upper and lower manifolds. A flow control valve is located between the reducing tee and the accumulator. The flow control valve has a flapper-type (swing gate) orifice plate, which allows free flow of fluid from the cylinder to the accumulator and a restricted flow through an orifice in the center of the plate from the accumulator to the cylinder.

The accumulator acts as a fluid stowage tank and has a high-pressure air connection from the upper head to the charging panel. The charging panel has a charging valve and a gauge valve with a gauge mounted between them, a high-pressure air supply valve, and a vent valve. The accumulator is charged to 750 psi and must have a reading of 2 (± 1) inches of fluid on the fluid sight indicator when the sheave damper is in its BATTERY position.

The end of the cylinder opposite the crosshead end has a flange threaded on it that mate with a flange on the buffer assembly. The two flanges are bolted together. The buffer assembly consists of a cylinder, buffer ram, spring, and fluid sight indicator. The purpose of the buffer assembly is to buffer the damper piston when returning to its BATTERY position.

Operation

An incoming aircraft engages the deck pendant, causing an increase of tension on the purchase cable. The purchase cable is reeved around the sheave damper crosshead in a manner that any increased tension experienced by the purchase cable will cause the sheave damper crosshead to move away from its BATTERY position. As the sheave damper crosshead moves, the damper piston moves, forcing fluid from the cylinder, through the fluid manifold, flow control valve, and fluid piping, into the accumulator. The resulting pressure buildup in the accumulator will be equal to the purchase cable pull.

Retraction of the sheave damper is automatic and occurs when accumulator pressure becomes greater than cable tension. Retraction normally occurs prior to full runout of the aircraft. The pressure buildup in the accumulator forces the fluid from the accumulator, through the fluid piping, the orifice in the flapper of the flow control valve, the reducing tee, and the fluid manifold, to the damper cylinder, therefore forcing the damper piston back to its BATTERY position. Just before the damper piston reaches its BATTERY position, the end of the damper piston rod comes in contact with the buffer ram.

The force of the damper piston rod pushing on the buffer ram compresses a spring inside the buffer cylinder. The spring is held in place by the buffer cylinder end plug. The compression of the spring buffers the return of the damper piston to its BATTERY position.

As the sheave damper crosshead reaches its BATTERY position, the battery-position indicator limit

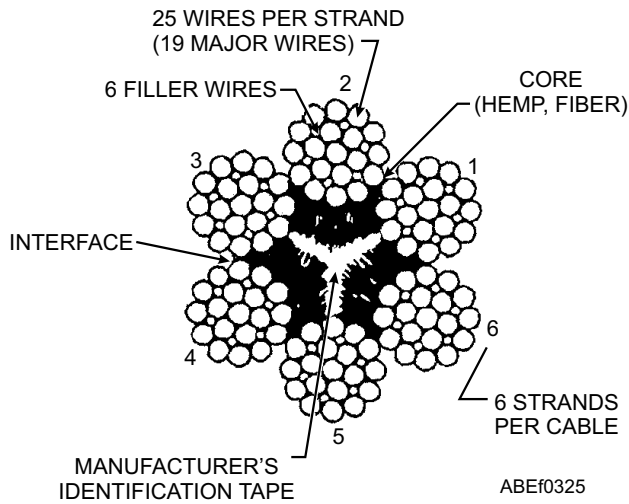

Figure 3-25.—Cross section of preformed sisal core purchase cable.

switch is engaged, and lights the battery-position indicator light at deck edge.

Purchase cable

The purchase cable is the wire rope reeved onto the arresting engine sheaves and fed through fairlead tubing and over the fairlead sheave to the deck gear on the flight deck. The purchase cable transmits the force of the landing aircraft from the deck gear to the arresting engine.

The polyester-core purchase cable is 1 7/16-inch diameter, 6 × 31 die-formed polyester-core construction with no filler wires, all wires are considered loading bearing, with a minimum breaking strength of 215,000 pounds. The die-formed construction is such that the outer wires present a relatively flat surface, giving it the appearance of being worn even when new.

As a result Q reading, as performed on the sisal-core purchase cable, are not possible. Inspection and replacement will be based on broken wire criteria.

The sisal-core purchase cable is 1 7/16-inch diameter, 6 × 25 filler wire construction, right-hand lay, lang lay cables with a minimum breaking strength of 195,000 pounds. The 6 × 25 filler wire construction means that the cable is made up of 6 strands with 19 major wires and 6 filler wires per strand. (See fig. 3-25.) The filler wires provide shape and stability to the strand. Lang lay denotes cables in which the wires of the strand and the strand are twisted in the same direction so that the outer wires in the lang lay cables run diagonally across the longitudinal axis of the cables.

The purchase cable is made from high-strength, uncoated plow steel. A hemp center, made from resilient oil-impregnated hemp, serves as a foundation for the strands, keeps the strands evenly spaced, and prevents them from bearing against each other. The hemp center also aids in lubrication of the inner wires. Within the hemp center is buried a paper or plastic strip bearing the name of the manufacturer. New purchase cables are provided on a double reel with each reel containing 1100 feet of cable. The purchase cable used on a barricade engine is of the same wire rope construction but is provided as a single cable, 2100 feet in length with a poured terminal on one end.

Poured threaded terminals are fitted on each end of the purchase cables. A clevis socket is screwed onto the threaded terminals to connect the purchase cables to the crossdeck pendants one end, the other end is connected to a coupling on the cable anchor damper operating piston rod (fig. 3-26.)

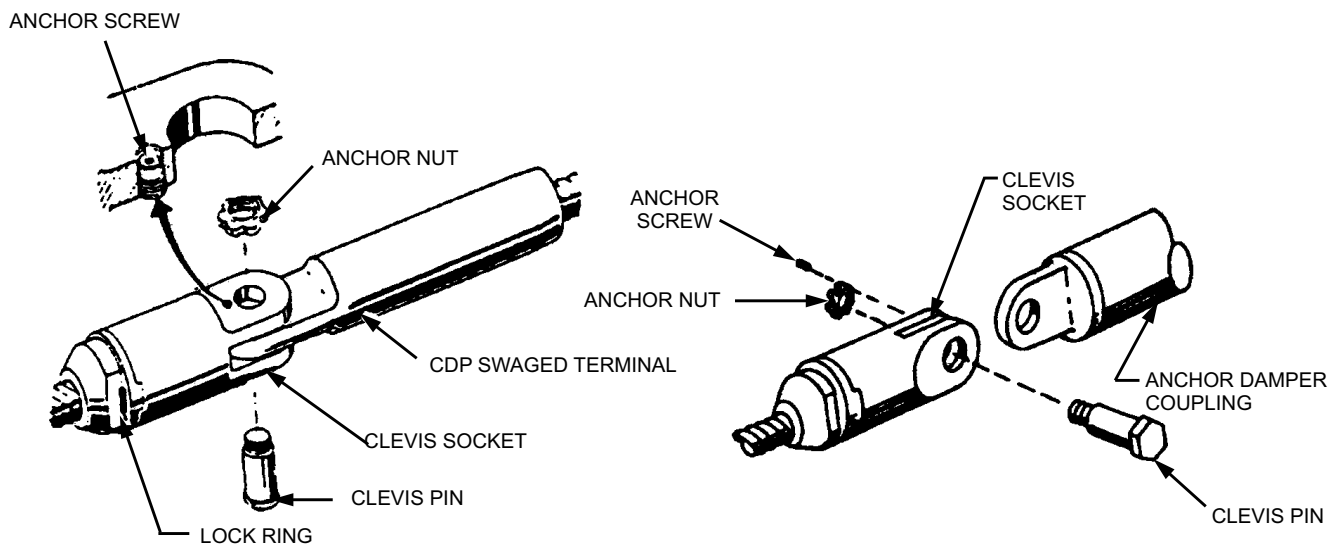

Figure 3-26.—Purchase cable attachments.

The Mk 7 arresting engines have an 18:1 reeve ratio, which means for every foot of ram travel there are 18 feet of purchase cable payout. The number of sheaves on the crosshead determines the reeve ratio. The types of reeves used on the Mk 7 arresting engines are 18:1 single reeve on pendant engines, and 18:1 endless reeve on barricade engines. The endless reeve barricade engines use only one purchase cable with the two bitter ends terminating on the flight deck and connected to the barricade. The single-reeved pendant engines require two purchase cables, one reeved around the 28-inch pitch diameter sheaves and one reeved around the 33-inch pitch diameter sheaves of the fixed sheave and crosshead assemblies.

FAIRLEAD SYSTEM SHEAVES

Three types of sheaves are used in Mk 7 arresting gear. They are the horizontally mounted retractable sheave, the vertical through-deck sheave, and the fairlead sheave. All these sheaves are designed to accommodate 1 7/16-inch diameter purchase cable and are made of forged aluminum alloy.

A typical sheave includes a base and cover that retains the sheave assembly. See figure 3-27. Two grease fittings provide access for lubricating the sheave bearing and spacers. The sheave assembly has three races: an inner race, a bearing race, and an outer race. Mounted with each sheave is a two-piece concentric spacer. The inner spacer is made of steel and is the lubricant distributor. The outer spacer, made of phenolic, is bonded to the sheave, provides a bearing surface, and is a lubricant retainer for the sheave. The horizontal and vertical sheaves are identical except for their mounting arrangement.

The function of a retractable sheave is to provide a means of lowering deck sheaves that would interfere with the passage of aircraft and deck equipment when in the raised operating position. Figure 3-28 is an example of a retractable sheave installation.

Each retractable sheave is operated by an electric motor unit controlled by a deckedge push-button station. In addition, an indicator light box is installed adjacent to the deckedge push-button station to show the position of the sheave—a green light when the sheave is fully raised, or a red light in all positions other than fully raised. The retractable sheaves may also be operated by means of handwheels in case of emergency. The handwheel is located below decks on the operating unit. To eliminate the chance of the retractable sheave being lowered inadvertently during

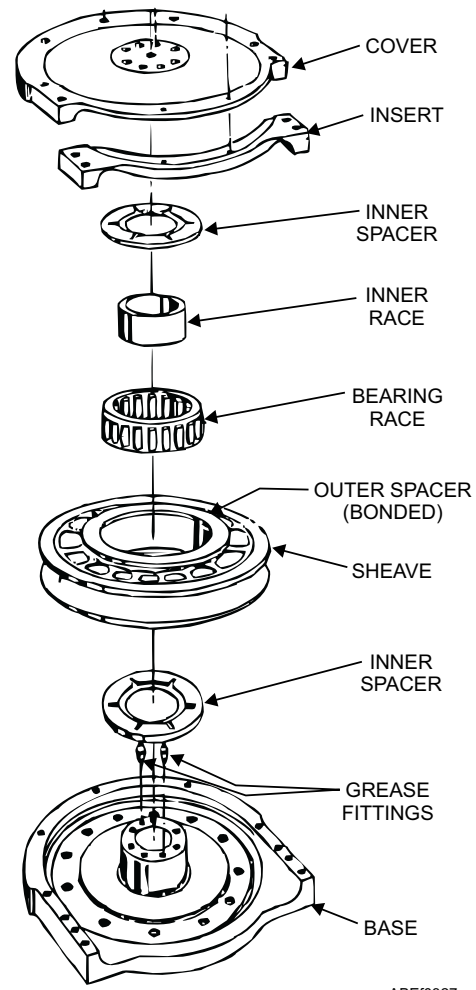

Figure 3-27.—Typical sheave assembly.

landing operations, the handwheel is removed from the unit whenever it is not actually being used.

The retractable sheave operating unit is bolted to the bottom of the retractable sheave assembly. It is accessible for maintenance and manual operation from the compartment that is directly below the retractable sheave.

The retractable sheave operating unit is a self-contained unit consisting of a high-torque electric motor, a geared drive system, and limit switches. See figure 3-29.

The motor is coupled to the wormshaft, which has a worm splined to the shaft. The worm engages the worm gear, which is free to rotate on the sleeve. There are two lugs on the back of the worm gear that, after some free rotation, engage two lugs on the back of the clutch bevel gear. The free rotation is to prevent putting an immediate load on the electric motor. The clutch bevel gear is splined to the sleeve, so that any rotation of the clutch bevel gear rotates the sleeve.

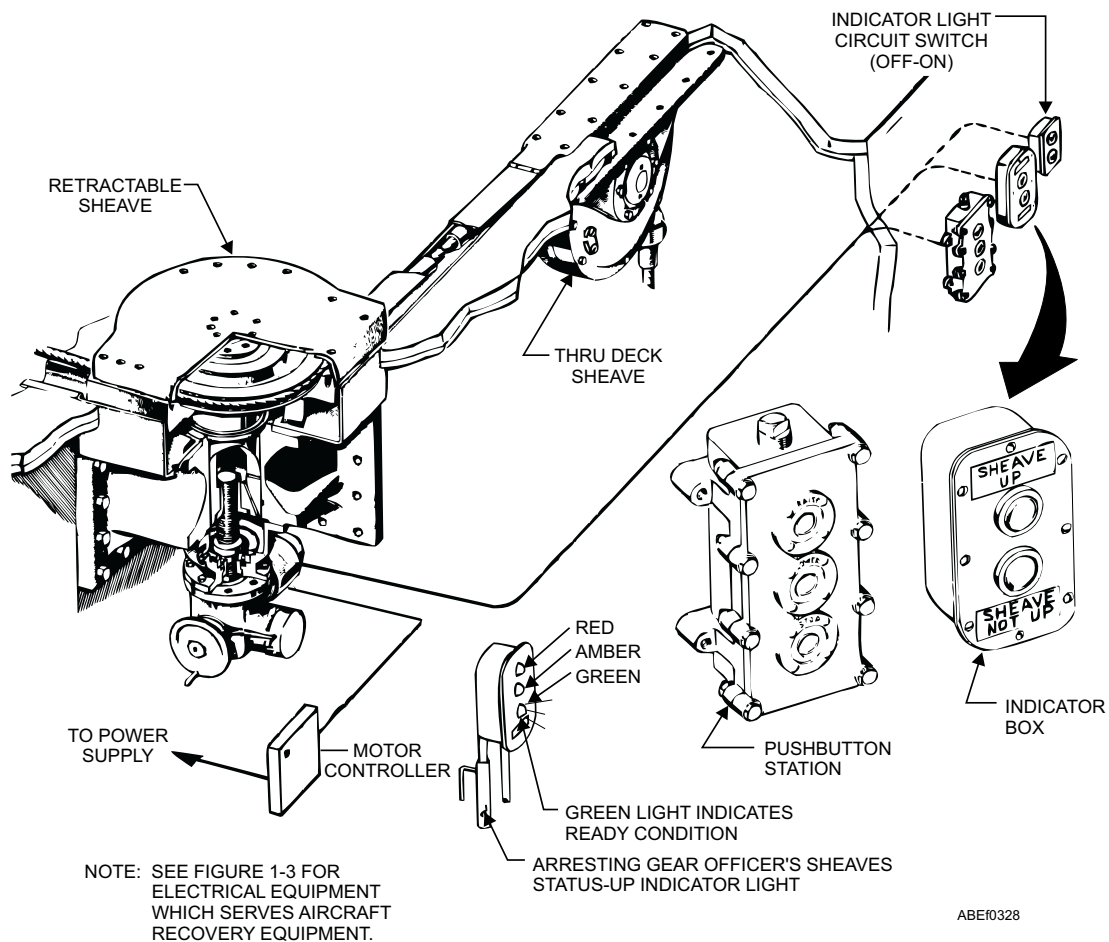
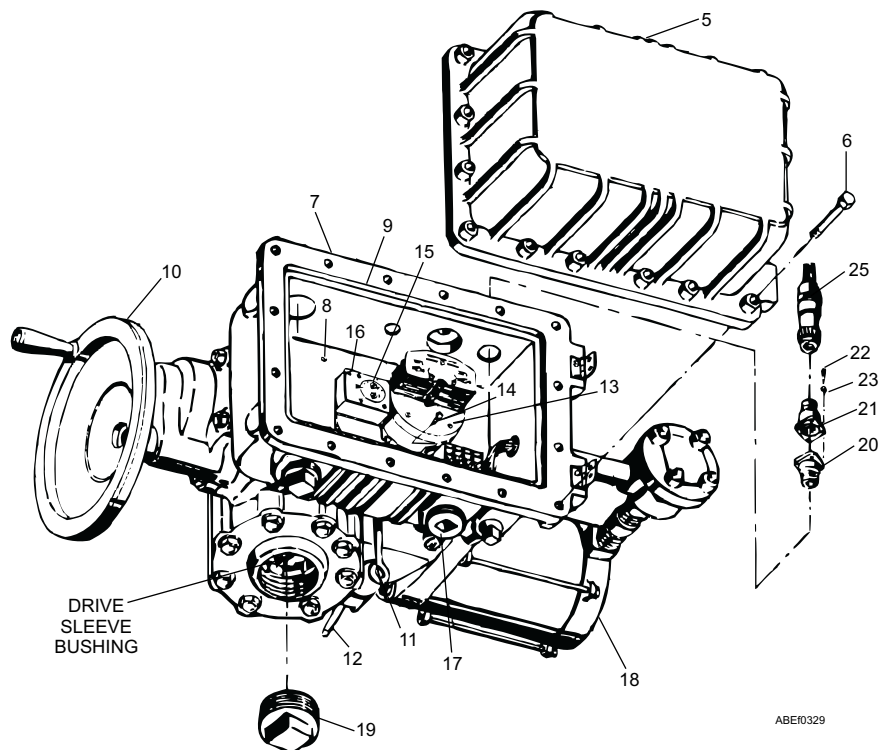

Figure 3-28.—Retractable sheave installation.



- | | | | |
|------------------------|-----------------------|--------------------------|-------------------------|
| 1. Geared limit switch | 5. Lower bevel gear | 9. Tripping plate washer | 13. Torque spring |
| 2. Motor | 6. Pinion | 10. Worm gear | 14. Declutch lever |
| 3. Housing | 7. Clutch fork spring | 11. Handwheel | 15. Worm |
| 4. Sleeve | 8. Clutch bevel gear | 12. Wormshaft | 16. Torque limit switch |

Figure 3-29.—Retractable sheave operating unit.

The sleeve is directly keyed to the lead screw of the retractable sheave so that rotation of the sleeve raises or lowers the sheave. The amount of sleeve rotation while the sheave is rising is governed by the adjustable geared limit switch, which opens the motor circuit when the sheave is fully up. An adjustable torque limit switch, actuated by the tripping plate washer, opens the motor circuit when the sheave is fully lowered and further provides overload protection for the unit. The worm is normally held in position with a heavy torque spring. If an obstruction under the sheave prevents the sheave from lowering, the sleeve cannot turn. Then the torque exerted by the worm exceeds the normal torque, causing the worm to slide along the wormshaft, pushing the tripping plate washer, and opening the torque switch. A handwheel is provided for manual operation, and a declutch lever is provided to change from motor to hand operation.

It is imperative that the deckedge operator knows whether the retractable sheave is in the UP position during landing operations. During night operations, visual sighting of the retractable sheave is impossible.

An arresting gear SHEAVE-UP and BY-PASS switch and indicator panel (fig. 3-30) is located aft of the arresting gear deckedge control station to indicate the status of the retractable sheave. The panel is wired into the clear/foul deck light and will prevent the

arresting gear officer from giving a clear deck signal if one or more of the retractable sheaves is not in the fully up position.

If a retractable sheave cannot be raised, the arresting gear officer directs that the affected deck pendant be removed from the deck. A CLEAR DECK signal can now be activated by closing the respective by-pass switch and thus overriding the shutdown arresting engine. An amber warning light on the by-pass switch and indicator panel visually indicates the by-pass condition. In addition, a three-lamp, deckedge indicator panel with red, amber, and green lenses, mounted aft of the deckedge control station, will indicate the retractable-sheave status. This panel will illuminate red when any of the retractable sheaves are down and green when all sheaves are up. In case one or more arresting engine and retractable sheave is bypassed, the deckedge indicator light will display the green and amber lights.

SEQUENCE OF OPERATION

Energizing the motor to raise the retractable sheave, by pressing the RAISE push button, causes the motor to rotate a helical gear keyed to its shaft. This transmits the motor force to another helical gear on the wormshaft. The wormshaft turns the worm and drives

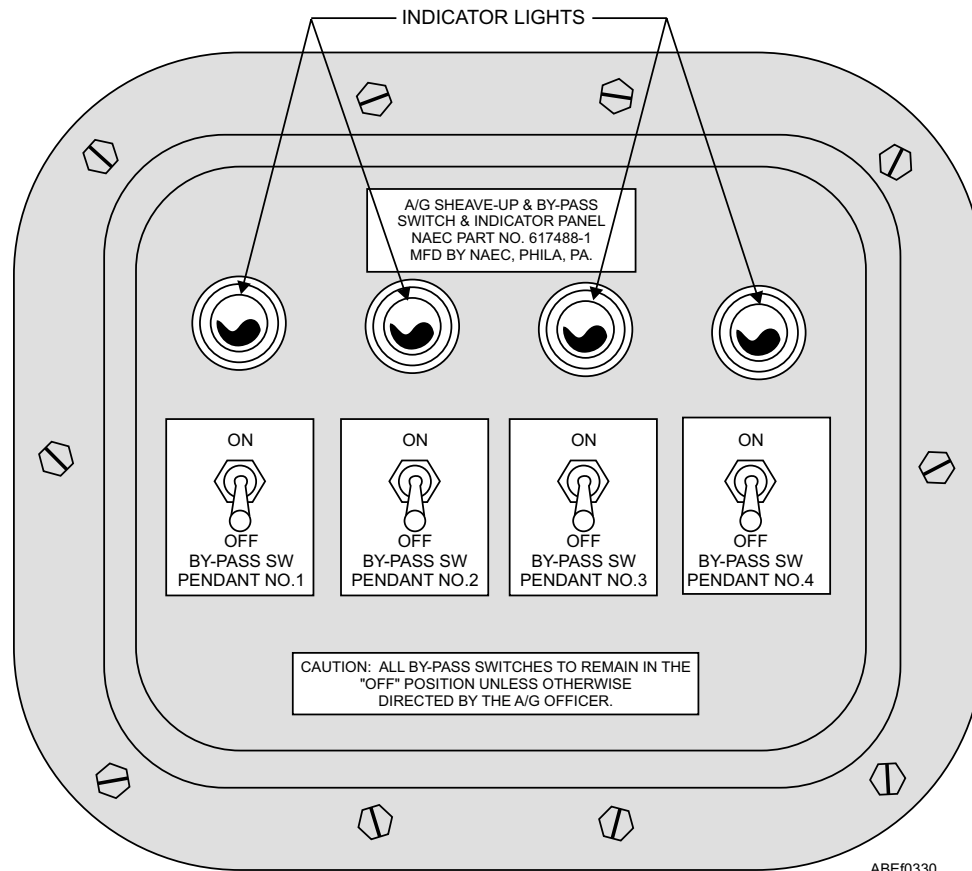

Figure 3-30.—Sheave-up and by-pass switch and indicator panel.

the worm gear on the sleeve. The worm gear rotates freely on the sleeve for part of the rotation, thus permitting the motor to gain speed before full loading. As the worm gear rotates, the lugs on its face engage the lugs on the face of the clutch bevel gear. Rotation of the clutch bevel gear, which is splined to the sleeve, rotates the sleeve, which is directly connected to the screw of the retractable sheave, thus raising the sheave. When the sleeve rotates, the limit bevel gear, keyed to the sleeve, rotates to turn the pinion of the geared limit switch. This is the only function of the limit bevel gear. When a predetermined point is reached by the rotor of the geared limit switch, the RAISE circuit is broken and the raising operation ceases. As the geared limit switch is actuated, the green lamp (sheave UP lamp) will light in the deckedge light box.

Energizing the motor to lower the retractable sheave, by depressing the LOWER push button, causes the motor and the drive system to operate in the reverse direction. Again there is free rotation until the lugs on the worm gear make a complete revolution before striking the other side of the lugs on the clutch bevel gear. The sheave lowers until it is completely seated and opens the torque limit switch to break the motor circuit. If an obstruction prevents the sheave from descending, the worm, which is still rotating because of the force of the motor, does not turn the worm gear. The worm is driven axially along the wormshaft until the torque limit switch is opened by the tripping plate washer. The torque limit switch may be adjusted to permit the sheave to seal with a predetermined force before the circuit is interrupted. The torque spring then absorbs the remaining inertia of the system after the circuit is broken. During the time the sheave is lowered and raised up until the time the RAISE geared limit switch is tripped, the red (sheave NOT UP) lamp glows on the deckedge light box.

For manual operation, the handwheel must be mounted on its shaft and secured to the shaft with a setscrew. The declutch lever must then be thrown in a counterclockwise direction. This movement will slide the clutch bevel gear along the splined section of the sleeve to engage a gear on the handcrank shaft. When the handcrank is turned, the sleeve turns, rotating the sheave screw to raise or lower the sheave. The declutch lever remains in the clutch position until operation under motor power is resumed, at which time the handwheel is disconnected automatically by the clutch trippers. There is no danger to an operator if he or she is turning the handwheel when the motor is started, because the handwheel is disengaged instantly without shock or jolt.

Thru-deck Sheave

The thru-deck sheave (fig 3-23) is mounted vertically and it guides the purchase cable between the sheave damper and the retractable sheave installation.

Fairlead Sheaves

Fairlead sheaves (fig. 3-23) are single sheaves that are installed at points in the drive system where the purchase cable require a change of direction. The number of fairlead sheaves varies based on engine location in relation to the location of the anchor and sheave dampers.

Crossdeck Pendants

The polyester-core crossdeck pendant are made of 1 7/16-inch diameter, 6 × 30 flattened strand polyester core construction with no filler wires, all wires are considered loading bearing with a minimum breaking strength of 205,000 pounds. To differentiate polyester-core CDPs from sisal-core CDPs the polyester-core terminals have a groove around the end where the cable enters the terminal. The deck pendant cable ends are equipped with swaged-type terminals. These terminals are pinned to the clevis and socket assembly at the purchase cable coupling for quick detachment during replacement.

The sisal-core crossdeck pendant are made of 1 3/8-inch diameter, 6 × 30 flattened strand construction, preformed, uncoated lang lay wire rope with a minimum breaking strength of 188,000 pounds. Each wire rope is made up of 6 steel strands, each of which is a bundle of 12 major and 12 intermediate wires twisted around a triangular core of 3 to 9 wires. (See fig. 3-31.) The strands are twisted about an oiled-hemp center

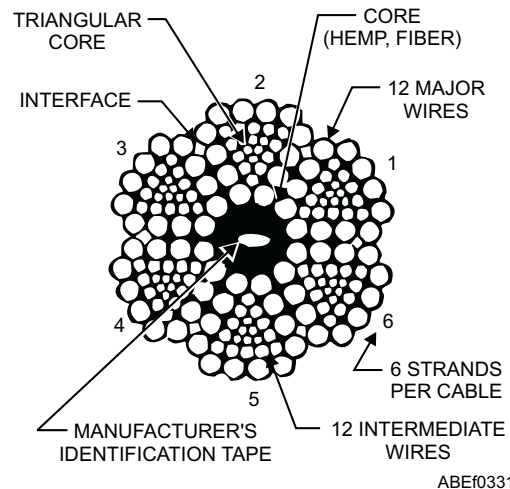

Figure 3-31.—Cross section of preformed sisal core 6 × 30 crossdeck pendant.

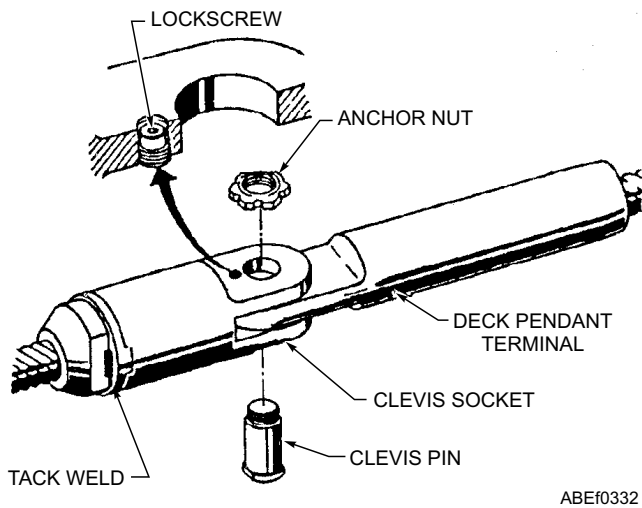

Figure 3-32.—Deck pendant terminal and clevis socket assembly.

core, within which is contained a paper or plastic tape strip bearing the name of the wire rope manufacturer. The function of the oiled hemp center is to provide a "cushion" for each strand and also to supply lubrication when the cable is under tension. The deck pendant cable ends are equipped with swaged-type terminals. These terminals are pinned to the clevis and socket assembly at the purchase cable coupling for quick detachment during replacement.

To remove a pendant, it is necessary to put slack in the cable. If the pendant has been retrieved and must be replaced, reduce the accumulator pressure to 200 psi and pull the pendant out a few feet, using a deck tractor. Hold the retracting valve open while the tractor is

pulling, then block the valve in the closed position to prevent retraction. It may be necessary to clamp a block on the purchase cable to prevent its slipping back due to its own weight. If a pendant is badly damaged during an arrestment and must be replaced immediately, either do NOT retract the pendant or retract the pendant only partially so that slack is left in the cable system.

Refer to figure 3-32, and perform the following task to replace a deck pendant. Screw the lockscrew into the clevis end socket, remove the anchor nut and pull out the clevis pin. Secure the eye end of the terminal of the new deck pendant to the clevis end socket of the purchase cable socket assembly by means of the clevis pin, anchor nut, and the lockscrew. Recharge the accumulator and retract the engine.

Deck pendants are provided as assemblies—not made up on board ship. Suitable handling facilities should be available. Spare pendants should be conveniently stowed, ready for quick rigging, since replacement of a deck pendant is sometimes an emergency procedure that must be performed quickly.

The replacement operation can best be performed by four separate crews. One crew is needed to pull out the pendant, one at each of the two couplings, and one to bring the new pendant on deck and roll it out and in position.

Impact Pads

Impact pads (fig. 3-33) are made up of several sections of polyurethane pads laid side by side and secured within an outer steel frame. The frame is both

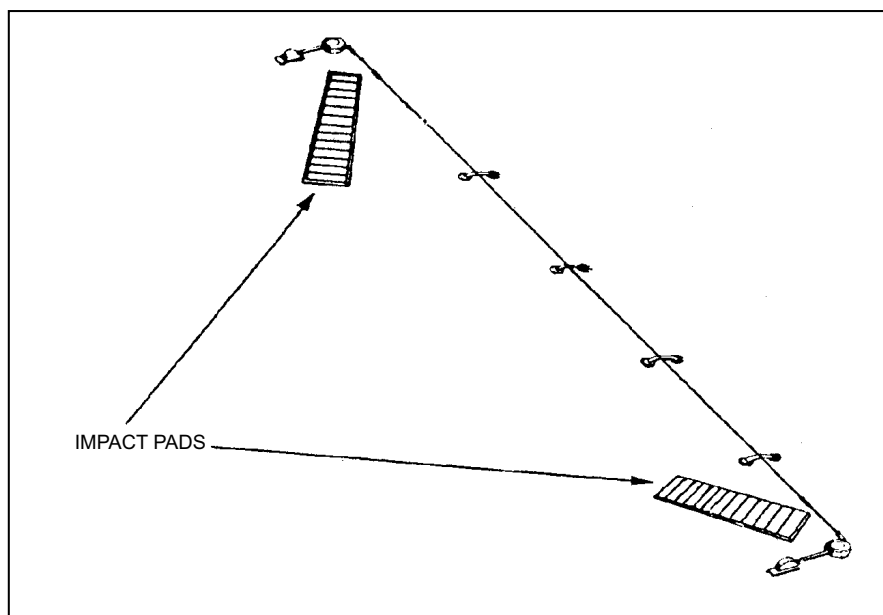

Figure 3-33.—Terminal impact pads.

welded and bolted to the flight deck inboard of each of the deck sheaves at an approximate 45 degrees forward facing angle. The bolted section of the frame is removable in order to replace worn impact pads as needed. Upon initial arrestment by an aircraft the terminal will impact on the pads instead of the steel deck, minimizing damage to the fittings, purchase cable, and crossdeck pendants.

Wire Supports

The wire supports provide a method of raising the crossdeck pendant off the flight deck to ensure arresting (tail) hook engagement of the incoming aircraft.

These wire supports are actually preshaped leaf springs that are designed to maintain a crossdeck pendant height of 2 inches minimum, measured from the bottom of the pendant to deck at its lowest point, and 5 1/2 inches maximum, measured from the top of the pendant to the deck at its highest point (fig. 3-34). The crossdeck pendant height is regulated by adjusting the wire support's contour height.

Each wire support is mounted directly to the flight deck. The forward end of the wire support spring is rigidly secured by use of a cam mounted in a deck recess and a follower and pin at the end of the wire support. The forward end of the spring is then held in

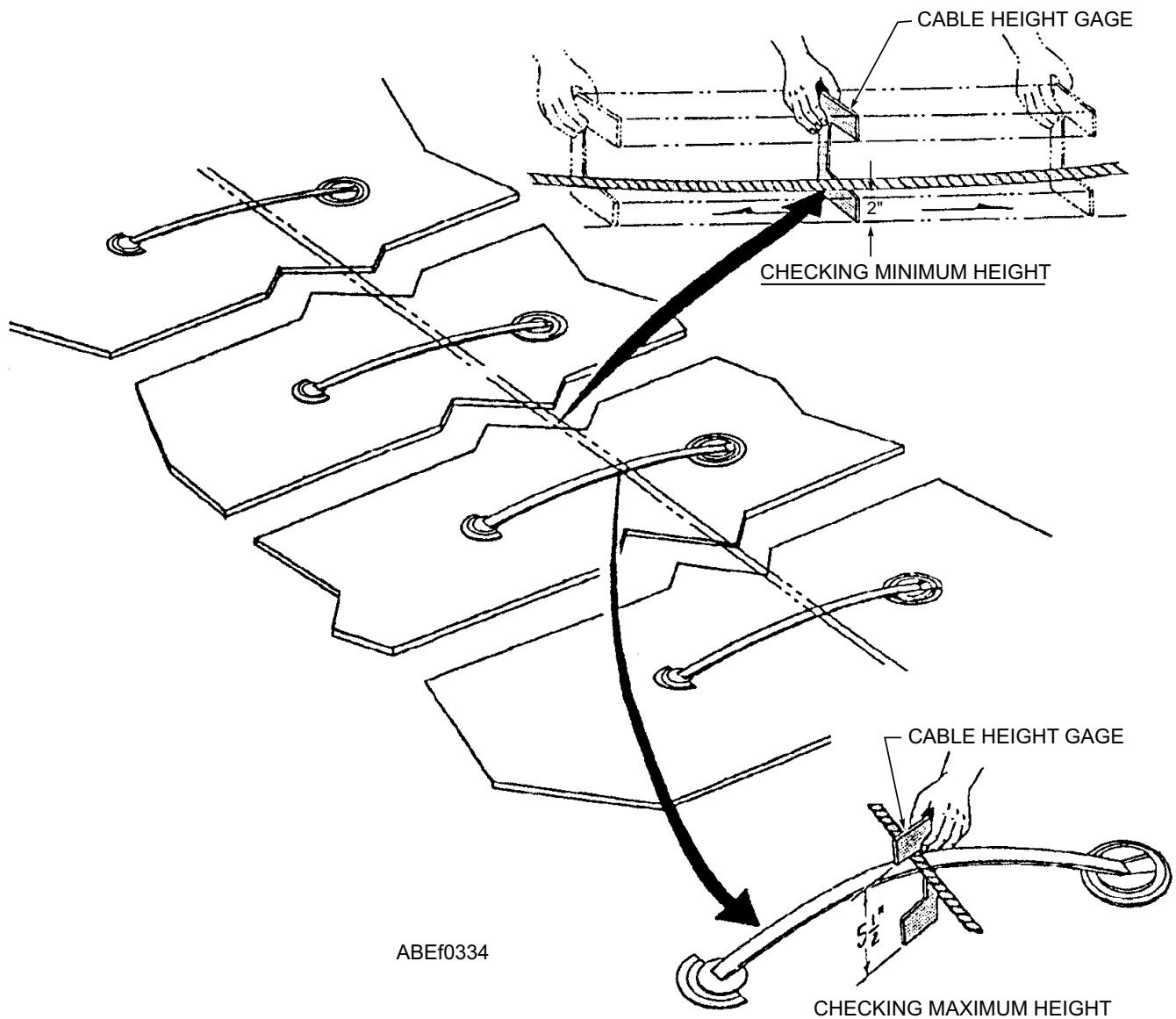

Figure 3-34.—Checking crossdeck pendant height.

the deck recess by the cam-end disc and the cam-end forward stop (fig. 3-35).

Adjustment of the wire support spring height is made at its aft end. The aft end of the wire support is also pinned, and set between adjustable forward stops as required (fig. 3-35).

Wire supports are replaced when they become deformed or damaged or when they fail to maintain the required crossdeck pendant height of 2 inches minimum and 5 1/2 inches maximum as measured using a cable height gauge (fig. 3-34).

REVIEW QUESTIONS

- Q1. What is considered the heart of the arresting engine?
- Q2. What permits the return of hydraulic fluid from the accumulator to the main engine cylinder?
- Q3. What is the capacity of the fluid stowage tank?
- Q4. What is the pitch diameter of the sheaves on the outboard shaft of the crosshead assembly?

Q5. What system transfers energy from an arresting aircraft to the arresting engine?

Q6. What reduces peak cable tension?

EMERGENCY RECOVERY EQUIPMENT

LEARNING OBJECTIVES: Describe the components of the emergency recovery equipment. Describe the operation of the emergency recovery equipment.

The emergency recovery equipment (barricade installation) is used when an aircraft cannot make a normal (pendant) arrestment. Emergency recovery equipment consists of the following:

- Barricade power package
- Pendant and anchor installation
- Barricade stanchions and controls
- Barricade webbing assembly
- Deck ramp installation

The arresting engines used for barricade arrestments are identical to those used for deck pendant

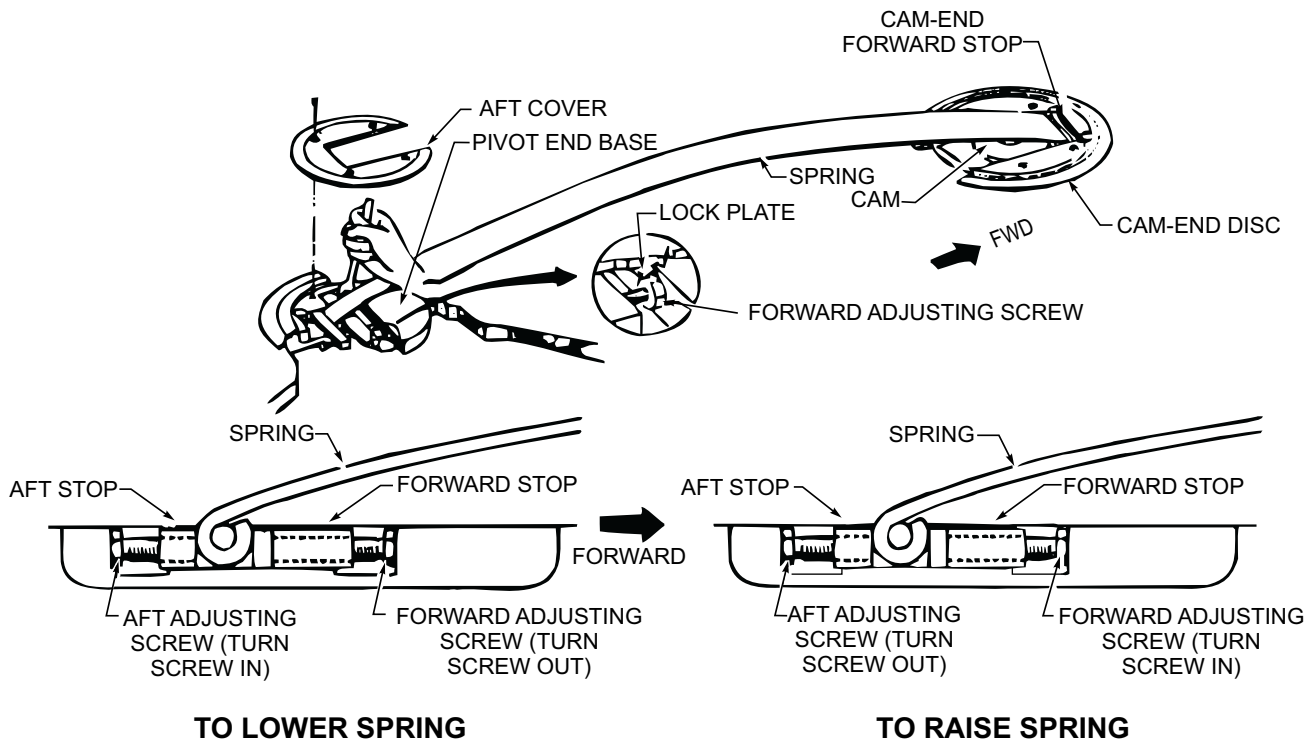

Figure 3-35.—Adjusting the wire support leaf spring height.

ABEf0335

arrestment with four exceptions: (1) no fluid coolers are installed, (2) barricade engines are endless reeved, (3) no anchor dampers are installed, and (4) a short-stroke control valve cam is used on most carriers.

BARRICADE WEBBING ASSEMBLY

Since barricade arrestments are emergency situations, barricade-rigging operations must be swift and efficient. The barricade webbing assemblies (fig. 3-36) are assembled and stored in an area where the webbing assemblies will be readily accessible when an emergency situation arises. The barricade storage room is equipped with a rack designed to stow three barricades simultaneously:

- READY— Jet Barricade
- STANDBY— Jet Barricade
- PRACTICE— Jet Barricade

The E2/C2 barricade is also stowed in the stowage room. The storage area for the webbing assemblies must be dry and must protect the webbing from exposure to direct sunlight. The effects of water on a barricade webbing assembly will result in the loss of approximately 10 to 15 percent of the webbing's strength and its weight increases by approximately 40 to 45 percent. However the strength loss and increase in weight are not permanent. When the webbing is dry to the touch the original barricade strength and weight are regained .

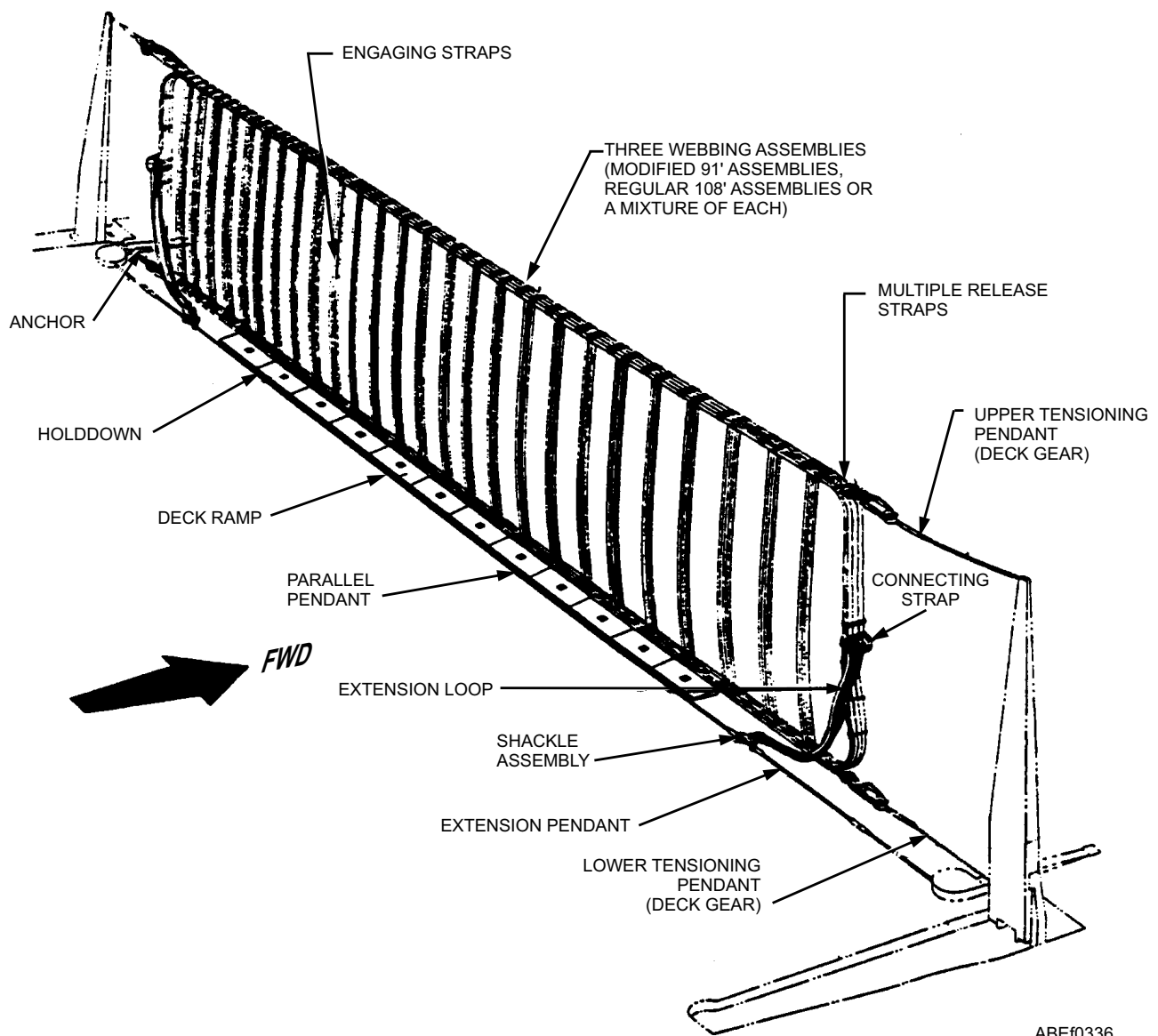

Figure 3-36.—Barricade webbing installation.

ABEf0336

Newly constructed barricade webbing assemblies may be brought out of storage and used as follows:

- If used for three practice rigs, it can still be used as a "ready" barricade for engagements.
- If used for four or more practice rigs, it cannot be used as a "ready" barricade.

When an aircraft is required to make an emergency landing, the nose of the aircraft passes through the barricade and allows the vertical (engaging) straps to contact the leading edges of the wings and wrap about the aircraft (fig. 3-37). The barricade installation then passes the force of arrestment through the purchase cable to the arresting engine. After arrestment, the barricade and attached hardware are discarded.

Currently, there are two types of barricades (two configurations) available to the fleet. Both types consist of all-nylon webbing assemblies, placed one on top of

the other and bundled together to make up one barricade installation (see fig. 3-36).

The polyurethane semicoated barricade uses three separate webbing systems to make one main webbing assembly

Each semicoated barricade webbing system is composed of upper and lower horizontal load straps (see fig. 3-36) joined together at the ends by nylon velcro tie-down straps. (The rolled edges of the upper and lower load straps are coated with polyurethane to reduce wear and damage caused when the barricade is dragged into position for use.)

Vertical engaging straps, are looped around the upper and lower load strap of each webbing system and sewn.. The spacing between the vertical engaging straps affords equalized loading of the barricade during arrestment. One webbing assembly, effects equalized loading every 4 feet along the wing's leading edge

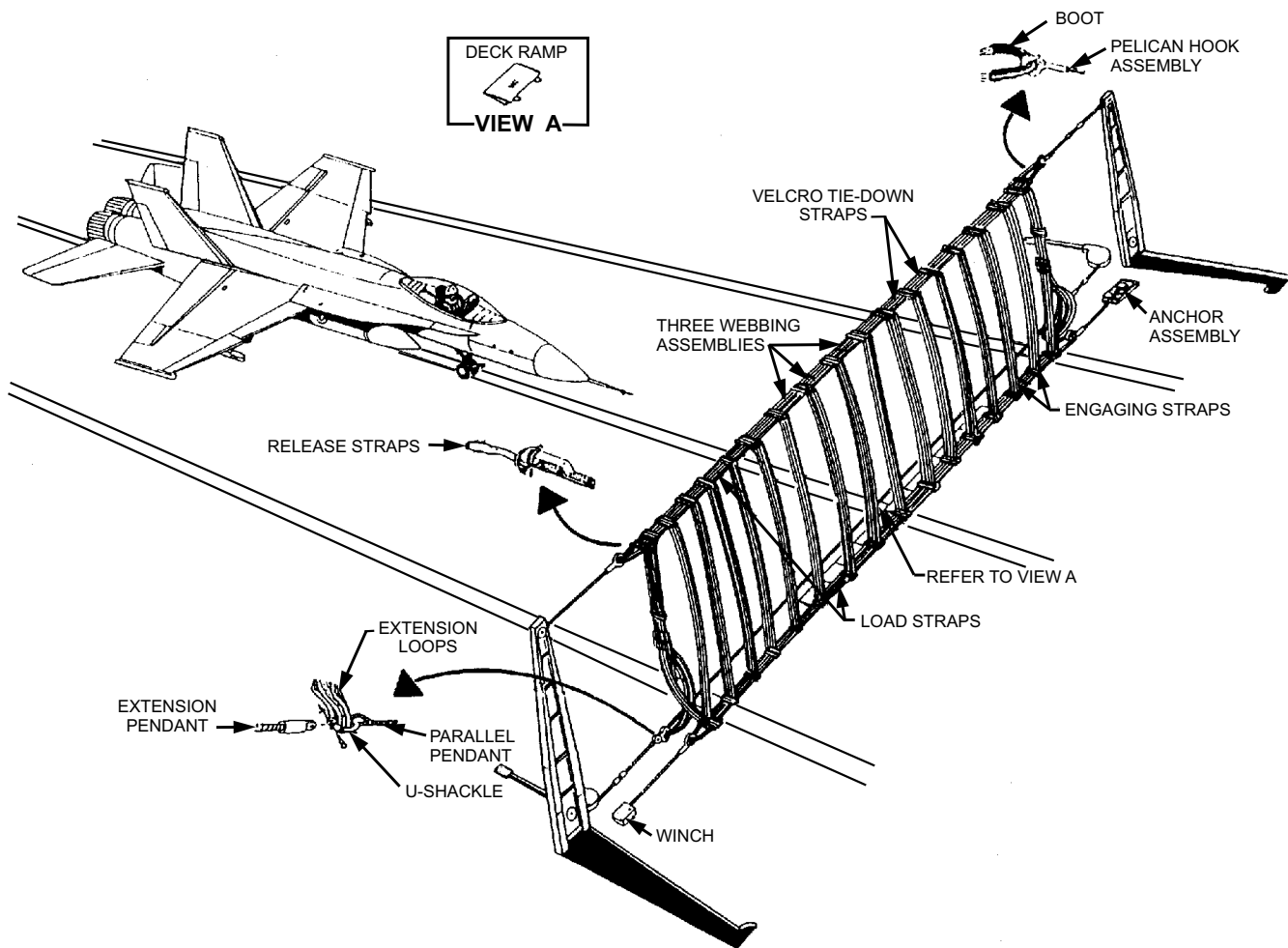

Figure 3-37.—Emergency arrestment.

ABE3f0337

because of the staggered arrangement of the vertical engaging straps.

The second barricade configuration (fig. 3-38) is the E-2/C-2 barricade. A 40 foot opening in the center of the webbing is designed so that props of the E-2/C-2 aircraft can pass through it with minimal damage to aircraft during arrestment. The E-2/C-2 barricade installation is comprised of an uncoated, double webbing assembly which is factory preassembled, boxed and shipped ready to rig.

DECK RAMPS

There are 12 portable deck ramps. They should be numbered 1 through 12 from port to starboard. The numbering should be large enough to facilitate easy identification and placement in corresponding positions on the flight deck.

The purpose of the deck ramps is to secure the lower load straps in place and cause the aircraft nose wheel to ride up and into the barricade assembly. This protects the lower load straps and also prevents the aircraft from nosing under them during a barricade arrestment.

Deck ramps are normally installed by V-1 division personnel during barricade rig evolutions.

MULTIPLE-RELEASE ASSEMBLY

The multiple-release assemblies provide the connection between the upper and lower load straps of the barricade and the tensioning pendants of the barricade stanchions. They serve to release the webbing assembly during an aircraft engagement (figs. 3-36 and 3-38.)

The multiple-release assembly consists of a number of release straps attached to loops at the ends of

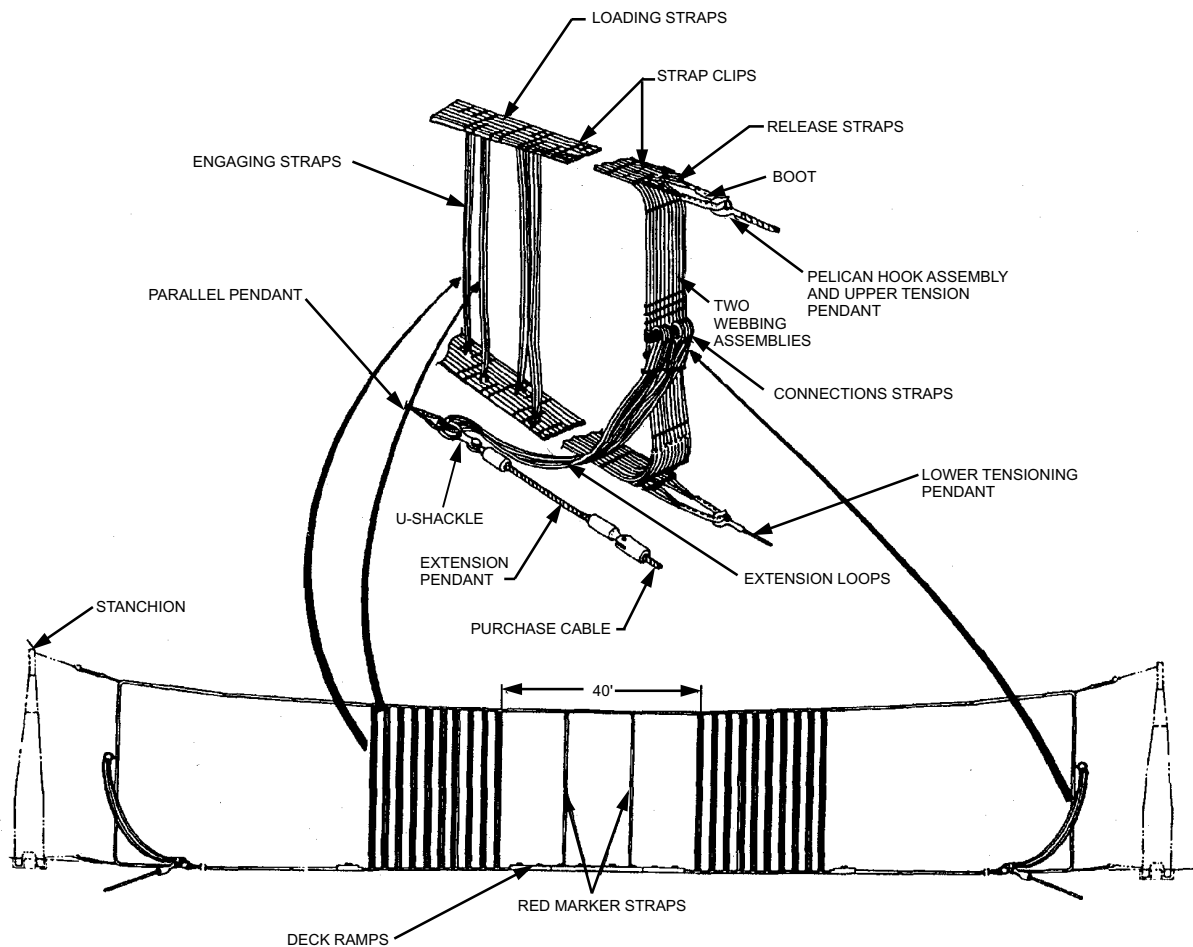

Figure 3-38.—E2/C2 aircraft barricade installation.

ABEF0338

the load straps. They are then attached to the tensioning pendants by a pelican hook assembly. During an emergency arrestment, the force of the aircraft engaging the barricade breaks the multiple-release straps, releasing the barricade from the tensioning pendants allowing it to fall over the aircraft. The energy of the engagement is then transferred from the barricade through the purchase cable to the arresting engine.

BARRICADE STANCHIONS

Barricade stanchions house the winches that tension and support the barricades. They further provide the structure on which the barricade is raised or lowered.

Except for differences of location and position of the actuating apparatus—deckedge, above or below deck—port and starboard stanchions are identical. The

port stanchions with their actuating apparatus are described in this chapter. Barricade stanchions (fig. 3-39) are welded steel, tray-shaped assemblies that consist essentially of a base on which is hinged the frame. Each barricade frame contains the winches, sheaves, and pendants used to tension the upper barricade webbing load strap.

Each barricade stanchion is provided with a slot, at the top of the inboard side, through which passes the upper tensioning pendant. The frame moves as a hinge around the two stanchion shafts, the barrel of the hinge being the base and the knuckles of the hinge being the hubs of the stanchion frame. The two shafts act as the pins of the hinge. The actuating arm is keyed and pinned on the outer shaft and is pinned to a holder on the stanchion. Rubber bumper pads are bolted in the deck recess to cushion the shock of lowering the stanchions.

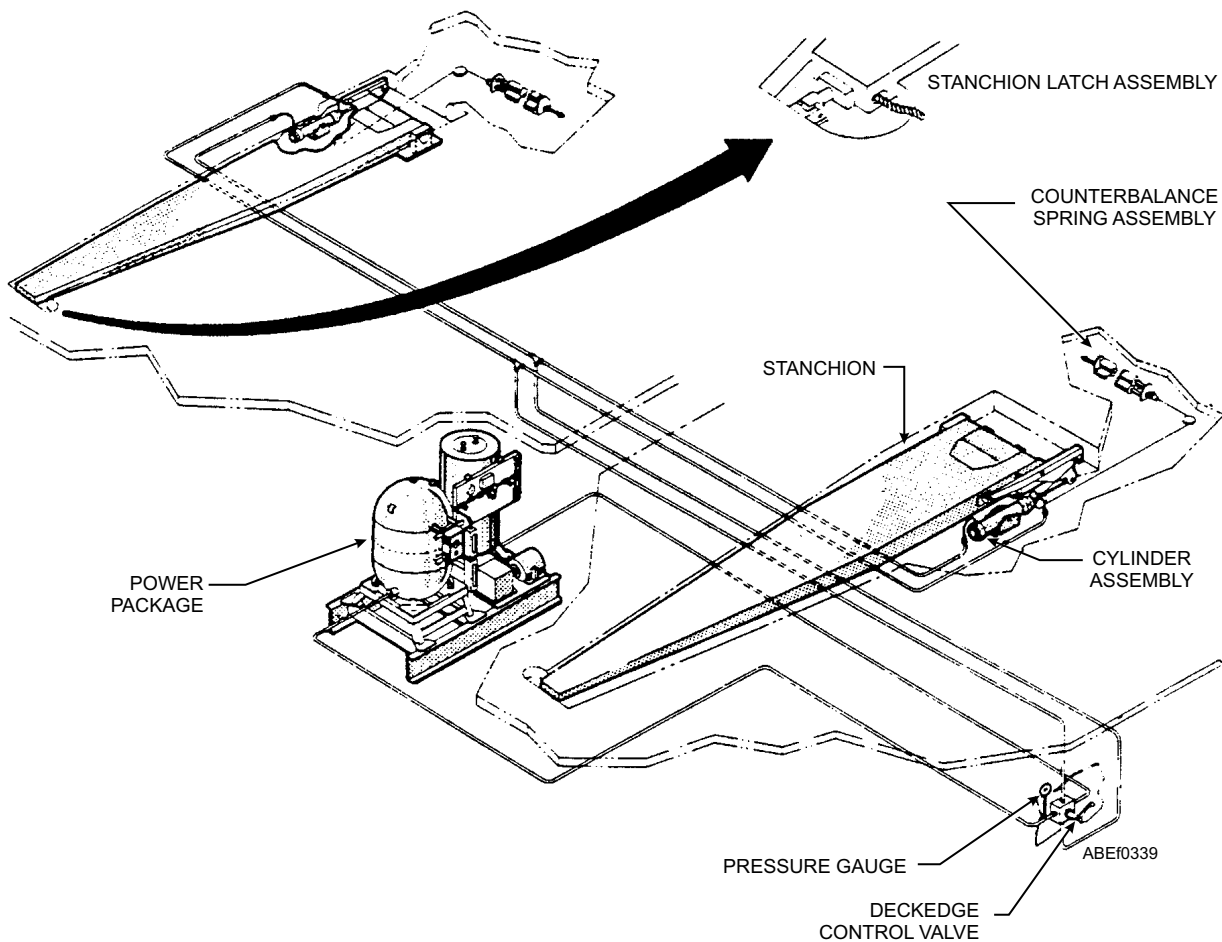

Figure 3-39.—Barricade stanchion installation.

PENDANT AND ANCHOR INSTALLATION

The pendant and anchor installation (fig. 3-40) is the means by which the barricade webbing is suspended and tensioned to maintain its 20-foot midspan height above the flight deck. Components comprising the pendant and anchor installation are: four wire rope tensioning pendants, two stanchion mounted winches. A deck mounted winch assembly, and an anchor assembly.

Stanchion mounted winches

One winch is mounted in each barricade stanchion and is attached to the tensioning pendant of the upper loading strap of the barricade.

Deck winch

The deck winch, through the tensioning pendants provide a means of tensioning the starboard side lower loading strap of the barricade webbing (see fig. 3-40).

Anchor assembly

The anchor assembly, through the tensioning pendants provides a means of tensioning the port side

lower loading strap of the barricade webbing (see fig. 3-40).

Tensioning pendants

Tensioning pendants provide the link between the winches, anchor and loading straps to keep the straps in the correct position when a barricade is rigged (see fig. 3-40).

STANCHION HYDRAULIC CYLINDER

The hydraulic cylinder (fig. 3-41) raises and lowers the barricade stanchion when hydraulic fluid under pressure is introduced into the cylinder on either the raising side of the piston or the lowering side of the piston. A front cap (3) and a rear cap (4) are each attached to the cylinder ends by bolts and sealed by an O-ring (13) and backup rings. Contained in the cylinder (2) are a piston (1), a piston rod (5), and two plungers (6), one on each side of the piston. The piston and plungers are held in position on the rod by a castellated nut and secured by a cotter pin. The piston and piston rod are sealed by an O-ring (13) and backup rings. The piston is fitted with two packing followers, two sets of V-ring packings (12), four rings each, and two piston

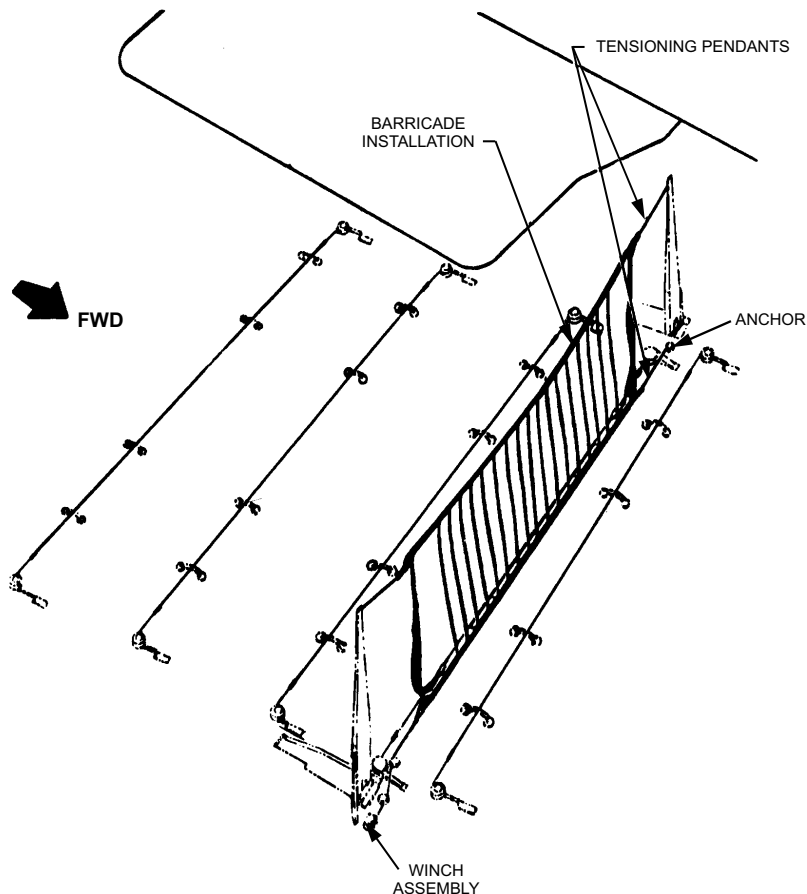
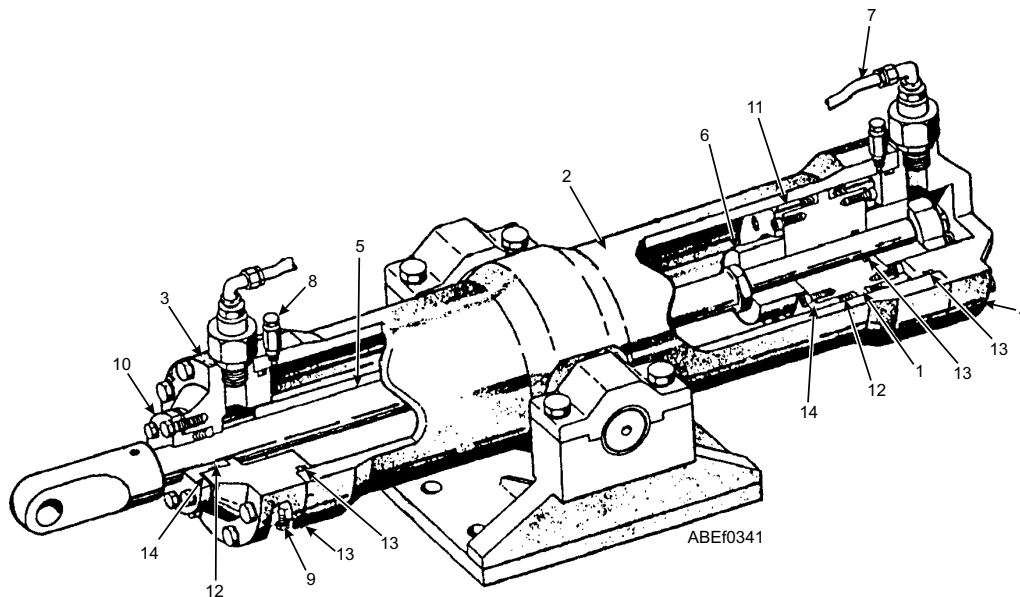

Figure 3-40.—Pendant and anchor installation.

ABEF0340



- | | |
|---------------|------------------------|
| 1. PISTON | 8. VENT VALVE ASSEMBLY |
| 2. CYLINDER | 9. PLUG |
| 3. FRONT CAP | 10. PISTON ROD GLAND |
| 4. REAR CAP | 11. PISTON GLAND |
| 5. PISTON ROD | 12. PACKING |
| 6. PLUNGER | 13. O-RING |
| 7. HOSE | 14. SHIM |

Figure 3-41.—Hydraulic cylinder assembly.

glands (11) secured by bolts, each safety wired. Shims (14) are provided between the piston face and piston gland to obtain the proper packing float. The piston rod is sealed where it extends through the front cap (3) by four V-ring packings (12), a spacer, and piston rod gland (10) secured by bolts and washers. Shims (14) are provided to obtain proper packing float. A terminal is attached to the end of the piston rod and is secured by a setscrew. The front cap and rear face are each fitted with a tailpiece, an adapter, an orifice plate, a union nut, and an elbow to attach hose; joints are sealed by O-rings

and packing. A vent valve assembly (8) and plug (9) are located at each end of the hydraulic cylinder to vent air or drain fluid.

COUNTERBALANCING SPRING

The counterbalancing spring supplements the force of the stanchion cylinder in raising the stanchion, and cushions the contact of the stanchion with the deck.

The counterbalancing spring (fig. 3-42) is a group of three compression spring units (5) comprising five

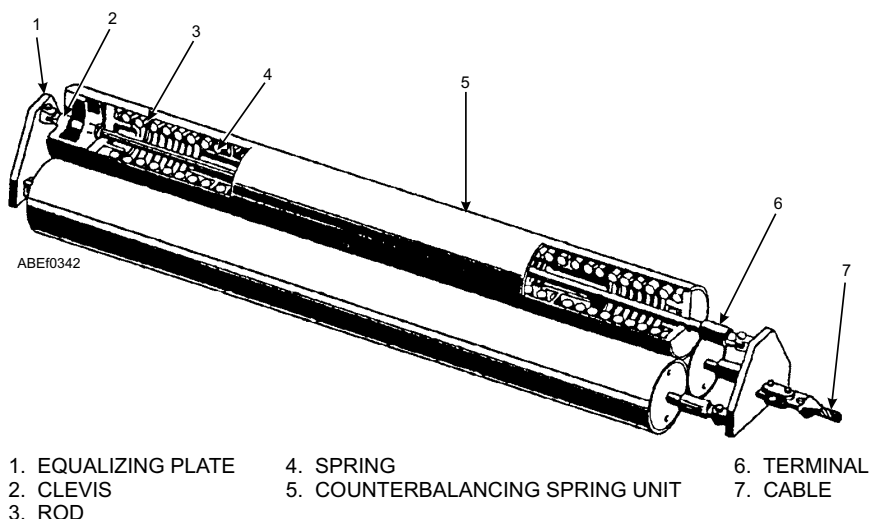

- | | | |
|---------------------|---------------------------------|-------------|
| 1. EQUALIZING PLATE | 4. SPRING | 6. TERMINAL |
| 2. CLEVIS | 5. COUNTERBALANCING SPRING UNIT | 7. CABLE |
| 3. ROD | | |

Figure 3-42.—Counterbalancing spring assembly.

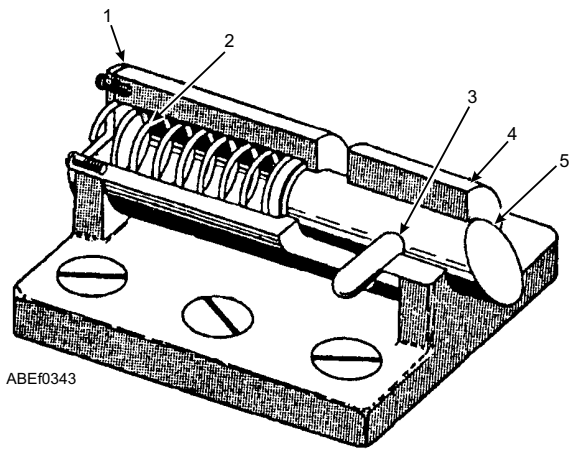

ABEf0343

- | | |
|--------------|----------|
| 1. END PLATE | 4. BODY |
| 2. SPRING | 5. LATCH |
| 3. PIN | |

Figure 3-43.—Stanchion latch assembly.

individual springs (4) each. It is designed to act as a single spring by means of rods (3) that pass through each set of springs and end in eyed terminals (6). The inboard ends of the rods are bolted to clevises (2), which are welded to an equalizing plate (1). The plate has a threaded adjustable rod that is secured to the ship's structure to hold the inboard ends of the spring unit.

The outboard ends of the rods are bolted to a similar plate, which has a welded clevis outboard, through which is bolted the eyed terminal of the counterbalancing spring cable. The cable (7) runs through two sheaves and is then bolted through its terminal to the actuator arm of the barricade stanchion, below the point of attachment for the cylinder.

When the stanchion is lowered by the cylinder, the sets of springs are uniformly compressed and resist the force of the descent, and cushions its fall against the deck. Raising the stanchion slackens the spring cable and decompresses the spring, but this release of compression has no appreciable effect on raising the stanchion.

STANCHION LATCH

Stanchion latches are used to secure the stanchions to the deck in their DOWN position. Stanchion latches (fig. 3-43) are spring-loaded latches bolted to the subdeck and provided with a slotted frame, designed to allow the latch (5) to be retracted against the force of a spring (2), and turned to lock the latch open. When the stanchion is lowered, the latch may be engaged in a hole provided in the stanchion, and a spring will hold the latch in.

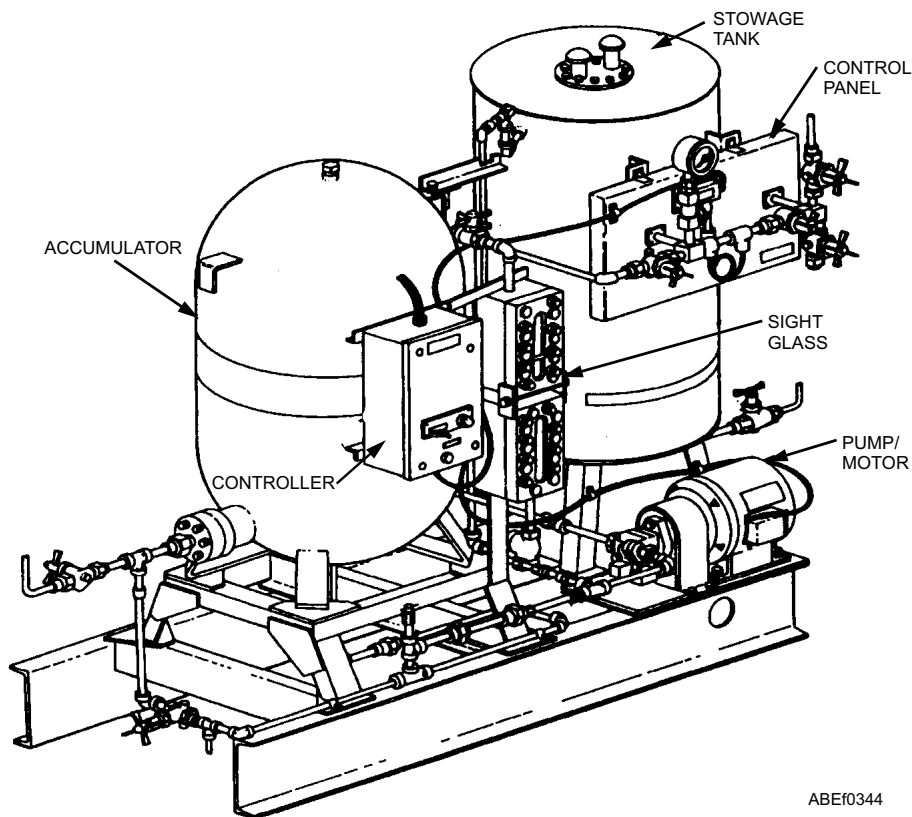

ABEf0344

Figure 3-44.—Barricade power package.

POWER PACKAGE

The power package (fig. 3-44) provides and maintains the fluid pressure required by the hydraulic cylinders to raise and lower the barricade stanchions. It consists of a base weldment, gravity tank assembly, control panel assembly, accumulator, motor controller, pump, electric motor, electrical system, and piping system.

The gravity tank assembly has a capacity of approximately 125 gallons and is the fluid reservoir in the power package assembly. Displaced fluid from the cylinder assemblies is returned to the gravity tank, and from there it is pumped back to the accumulator. The gravity tank is welded steel, closed at the top and bottom by flat plates. The top cover plate has an access hole, which is covered by a cap plate and gasket held in place by bolts. Tapped bosses welded to the cap plate are for breather vents. A liquid-level gauge is connected to the side of the gravity tank. An indicator plate is attached to the tank at the level gauge to show the proper fluid level.

The control panel assembly (fig. 3-45) is attached to the gravity tank by four bolts.

The panel consists of the panel frame (1), two piping support brackets (9), accumulator pressure gauge (6), pressure sensing switch (7), gauge valve (3), air-charging valve (5), vent valve (2), air supply valve (4), caution plate (8), and operating instruction plate (10). Necessary copper tubing and sil-braze fittings connect the panel to the accumulator assembly, to a ship's exhaust line, and to the ship's high-pressure air supply line. The accumulator pressure gauge (6) is used to indicate pressures ranging from 0 to 2,000 psi in the accumulator.

The pressure-sensing switch (7) is a piston type, contained in a splashproof housing. It is connected to the pressure line from the accumulator with a threaded adapter and a coil of tubing between the adapter and tee in the pressure line. The function of the pressure-sensing switch is to maintain accumulator pressure between 1,250 psi and 1,500 psi. It does this by opening or closing to stop or start the pump motor.

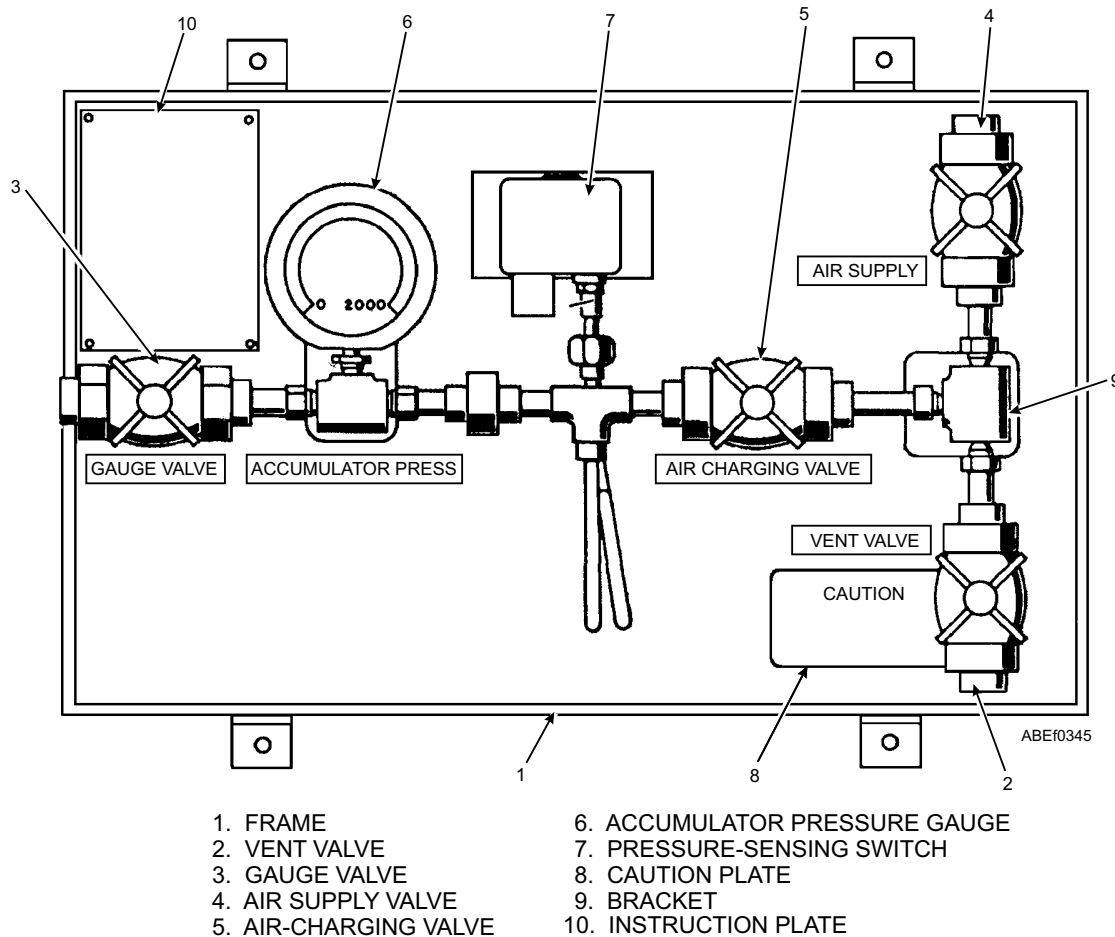

Figure 3-45.—Control panel assembly.

The pressure switch operates only when the motor controller switch is set at the AUTOMATIC position. The caution plate (8) is located next to the vent valve (2). It cautions all concerned to keep the vent valve open at all times except when charging the accumulator, and contains instructions for closing the vent valve when charging the accumulator.

A gauge valve (3) is furnished to maintain pressure in the accumulator when it is necessary to remove the pressure gauge (6). The air-charging valve (5) regulates the charging flow. The air supply valve (4) controls the flow intake of air to the control panel and accumulator. The operating instruction plate (10) contains basic operating instructions and a piping schematic.

The motor controller regulates the starting and stopping of the pump motor in conjunction with the pressure-sensing switch. The controller, operating magnetically, provides a switch control for OFF, AUTOMATIC, or RUN positions. The OFF position is used when the power package is secured. The AUTOMATIC position is used when the power package is to be operated, and the RUN position is used when it is necessary to bypass the pressure-sensing switch. Protective features of the controller include pilot circuit and motor overload protection and undervoltage release. A white light is mounted on the controller to indicate when power is available. When the switch is in the OFF position, the circuits from the controller to the motor and the pressure-sensing switch remain open, or dead. In the AUTOMATIC position, the motor starts when the contacts are closed in the pressure-sensing switch, and the motor stops when the contacts open. The RUN position is spring returned, and the motor runs only as long as the switch is manually depressed.

In the piping system, manual valves are placed in the lines to provide for operating and standby conditions and for maintenance. Each valve is tagged with a nameplate giving its number and normal operating position (OPEN or CLOSED). Miscellaneous equipment includes a check valve, fluid strainer, hydraulic pressure relief valve, and an air safety head. The check valve between the accumulator and pump prevents fluid pressure from backing up to the pump. The fluid strainer in the line between the gravity tank and the pump removes foreign matter before it enters the pump. The hydraulic relief valve connected to the line between the check valve and pump provides for pressure relief. The hydraulic relief valve is adjusted to crack open at 1,600 psi (minimum)

and open full at 1,750 psi. This line is equipped with a liquid sight indicator for visual checking of fluid flow, which would indicate an open relief valve. The air safety head, which ruptures at approximately 2,000 psi, is connected to the air line between the accumulator and control panel. It acts as a safety to prevent charging the accumulator and related components above their design limits. Two breather vents at the top of the gravity tank provide for passage of air out of or into the tank as the liquid level rises or lowers. A screen in the breather vent removes any foreign matter from incoming air.

BARRICADE OPERATION

During normal operations the system is put in the READY condition. The power package, which is located below deck and includes an accumulator and gravity tank, is to be placed in a READY condition as follows:

- Place accumulator pressure at 1,500 psi.
- Fill accumulator and gravity tank liquid to operating level.
- Open or close proper valves.
- Place motor controller switch on AUTOMATIC.
- Check controls for proper operation.
- Inspect barricade-tensioning pendants for fraying.

As shown in figure 3-46, after the latch at the top of the stanchion is released, the deckedge control valve lever is placed in the Raise position (No. 1), and the stanchions will raise simultaneously. Raising operations may be stopped and stanchions held in any position by placing the deckedge control valve lever in the Neutral position (No. 2).

To lower the stanchions, place the deckedge control valve lever in the Lower position (No. 3). Stanchions will lower simultaneously. Lowering operations may be stopped and stanchions held in any position by placing the deckedge control valve lever in mid-position (No. 2).

The deckedge control valve lever in mid-position (No. 2) is the standby position. It blocks all valve ports, and any passage of fluid is stopped when the valve is in this position. This position should be used to stop stanchions during raising or lowering or to hold the stanchions either up or down.

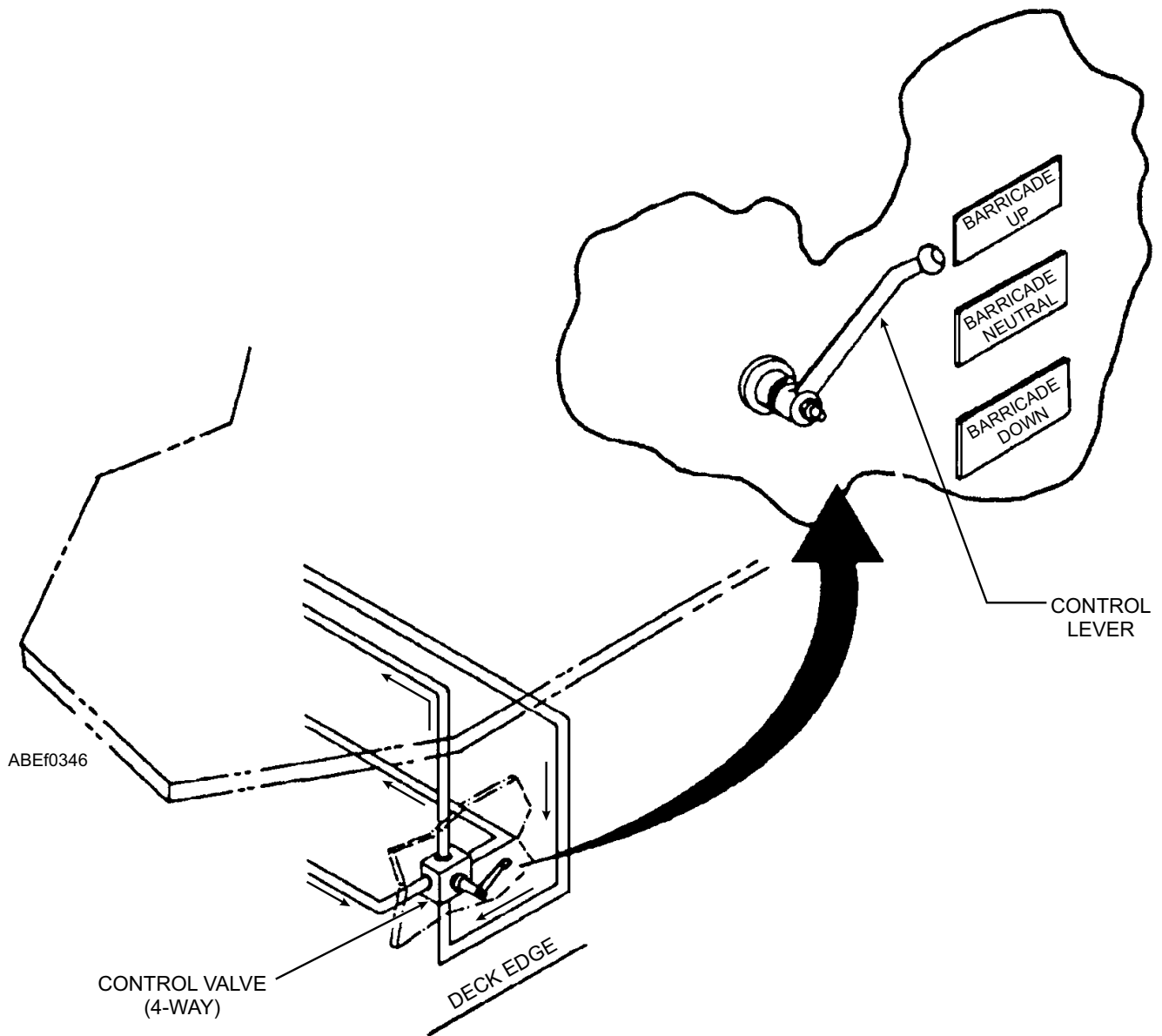

Figure 3-46.—Barricade stanchion controls.

CAUTION

The control valve lever must never be held or left in any position between 1 and 2 or 2 and 3, since this allows fluid to drain from the accumulator, through the system, to the gravity tank.

The power package accumulator does not contain sufficient fluid to raise and lower the stanchions more than three times without the pump operating. Approximately 20 minutes is required for the pump to replenish fluid to the operating level in the accumulator, if stanchions are cycled three times without the pump operating. The READY CONDITION for normal

operation specifies 1,500 psi accumulator pressure; however, stanchions will raise and lower, taking a longer period of time with a lower pressure, as is experienced if stanchions are cycled without the pump operating. Pressure at the start of the third cycle will be approximately 850 psi without the pump operating.

If the stanchions are cycled more than three times without the pump operating, air will enter the piping and cylinders, and fluid will overflow the gravity tank. It is then necessary to fill, vent, and charge the system as specified in the applicable operating manual.

During the READY and SECURE conditions, the following checks are to be made:

During the READY condition at 1-hour intervals, check the accumulator pressure, accumulator and gravity tank liquid levels, controller switch for AUTOMATIC setting, and make sure the pump is not operating when accumulator pressure is 1,500 psi or above.

During the SECURE condition, make a daily check of the accumulator pressure, accumulator and gravity tank liquid level, valves for position (open or closed), and controller switch for OFF setting.

The system must be operated WEEKLY to raise and lower the stanchions, to vent air from both ends of the hydraulic cylinders, and to check the operations of the system. It is not necessary to attach the barricade webbing during this exercise.

REVIEW QUESTIONS

- Q7. List the four differences between a pendant engine and a barricade engine.*
- Q8. What connects the upper and lower loads straps to the barricade stanchions?*
- Q9. When are the counterbalancing springs compressed?*
- Q10. What secures the barricade stanchions to the deck?*
- Q11. What is the barricade power package accumulator operating pressure?*
- Q12. What are three positions of the motor controller switch?*

MAINTENANCE PROCEDURES

LEARNING OBJECTIVES: Describe the procedures for replacing purchase cables. Describe the procedures for replacing packings.

Arresting gear must be kept ready for instant use. There is only one way such a condition may be effected; that is, by constant inspection, repair, and maintenance. Preoperational and postoperational inspection of all components is mandatory, as directed by the applicable MRC. Every section, topside, below deck, engine areas, and ready stowage must be prepared to function on command.

Maintenance can be divided into two broad categories: preventive maintenance and corrective maintenance. Preventive maintenance consists of routine shipboard procedures designed to increase the

effective life of equipment or to forewarn of impending troubles. Corrective maintenance includes procedures designed to analyze and correct material defects and troubles. The main objective of shipboard preventive maintenance is the prevention of breakdown, deterioration, and malfunction of equipment. If, however, this objective is not reached, the alternative objective of repairing or replacing failed equipment—corrective maintenance—must be accomplished.

Maintenance by the arresting gear crew must go beyond a wipedown and periodic lubrication. The arresting gear personnel must be instructed to alert the officer in charge to any signs of malfunction, wear, looseness, leakage, damage, or any other irregular conditions in the arresting gear equipment. They should also learn the physical location of all operating parts, cable runs, air supply lines, valves, electrical supply lines, switches, fuse boxes, tools, and spare parts.

Engine inspection should be visual, mechanical, and operational. The following general notes apply to maintenance throughout the arresting gear equipment:

- Mechanical inspection is performed while the engine is at rest. It consists of a security check, exercising the engine, and manipulating the controls. This inspection is a check for looseness, excessive play, improper operation of hidden parts, lack of lubrication, or any abnormal resistance to motion.
- Operational inspection consists of running all operable systems through a full cycle of operation, checking for smoothness of operation, proper timing, and synchronization.
- All maintenance performed on recovery equipment should be noted in the maintenance log for that particular unit.
- Changes in critical measurements should be logged so that they can be used to predict trends and avoid possible troubles.
- Wipe down all arresting gear equipment daily to remove dirt and grime.
- Remove rust; paint when necessary.
- Do not paint threads or finished machined surfaces.
- Check for loose or damaged bolts, nuts, and screws. Tighten or replace as required.

Replacement bolts should be of equal or greater strength than the original.

- All bolts should be tightened to the proper torque value.
- Check for hydraulic and pneumatic leaks.
- Be alert for any unusual sounds that may indicate malfunctioning equipment. Report these conditions to the officer in charge.
- Check spares on hand against allowable spares list. Replenish spare parts monthly.
- Maintenance personnel must establish and carefully maintain the Recovery Wire Rope History Chart, recording all wire rope data.
- The replacement of any O-ring, V-ring, or other pressure seal necessitates a high-pressure test of the equipment before resuming arresting operations. Before you can pressure test newly installed seals, it is necessary that the unit stand for a period of 1 hour before the seals can be accepted.

Once each year (or as modified by appropriate technical publications), drain the ethylene glycol from the system and replace with fresh fluid.

REPLACING PURCHASE CABLES

During recovery operations, malfunctions may develop in the engine and cable system, causing the purchase cable to pull out of the sheave arrangement or break below deck, close to or at the engine, resulting in shutdown of the system. Also, conditions occur in which initial reeving of the engine is necessary or old purchase cable is required to be replaced by new purchase cable. Any or all of these conditions can occur on single or endless reeved engines.

If the old cable is still reeved, do not pull it out. When possible, the old cable should be used to pull in the new. Even if the old cable is only partially reeved, it will prove useful. Reeving is very much simplified if cable already reeved in the proper way can be used. A decision must be made for each particular engine as to whether it is easier to feed the new cable from the engine and pull from the flight deck level with a tractor, or feed from the flight deck and pull from the engine with block and tackle. In either case, the cable should be pulled very slowly, and communication should be maintained between engine and flight deck, so that the pulling can be stopped quickly if there is danger of

pulling a kink into the line. If the purchase cable is severed below deck but still reeved, isolate the break and thread a 9/16-inch cable through the system and butt braze this to the longer length to provide a continuous line for pulling in the new cable.

The following procedures should be followed in replacing purchase cables:

1. Initial reeving of an engine is facilitated by hand-threading the complete fairlead system and engine with a length of 9/16-inch cable. After reeving the 9/16-inch cable, splice and braze the end to the purchase cable and pull the larger into the system with the smaller. This smaller-diameter cable is easier to push through the fairlead pipes and wrap around the sheaves before pulling in the purchase cable.
2. To thread the cable through the deck and fairlead sheaves, remove the sheave covers and pull out the sheaves. Push the cable through the fairlead pipes from sheave housing to sheave housing. Then slip the cable into the sheave groove as the sheave is replaced in the housing. When the cable is fully threaded, replace the covers.
3. In reeving the engine, use only the original, approved reeving pattern. Study the reeving diagram in the applicable NAVAIR maintenance manuals, and be careful to pass the cable over the sheaves in the approved sequence and through the appropriate fairleads and guides.
4. After the cable is reeved, the next step is to connect the anchor end of each length. Then the cable must be stretched taut to determine the correct location for the terminal of the opposite end.

New cables acquire a stretch over the course of the first several engagements. This lengthening of cables decreases the distance between crosshead and crosshead stop in the BATTERY position, and this in turn increases the fluid capacity of the hydraulic system and makes it necessary to add fluid to maintain the fluid level. If the distance from crosshead to crosshead stop in the BATTERY position becomes less than the minimum allowable clearance of 1 inch between the crosshead and the crosshead stop, it becomes necessary to crop the cable and repour a terminal to readjust the clearance to 6 inches between the crosshead and the stop. The clearance between the crosshead and crosshead stop with newly installed purchase cables is

set at 7 inches. New purchase cables will stretch very rapidly during the first few arrestments. The initial 7-inch dimension between the crosshead and the stop allows for this structural stretch, which causes a progressive narrowing of the gap distance between the crosshead and crosshead stop. After the purchase cable has been stretched and reaches the minimum allowable clearance of 1 inch between the crosshead and crosshead stop, a 6-inch dimension is used thereafter.

When it becomes necessary to rereeve a single-reeved engine, both purchase cables must be replaced. Reeving only one purchase cable on a single-reeved engine result in unequal length of the two cables, because of the initial stretch of the new cable. An offcenter deck pendant is an indication of one cable stretching more than the other. This condition could cause one of the purchase cable terminals to rest in the deck sheave. To correct this condition, you will have to crop the longer cable and repour the terminal.

During arrestment operations, torque builds up in the purchase cables. Failure to remove this torque results in accelerated wear and bird-caging of the cables, with vastly increased susceptibility to failure. Compliance to detorquing methods at specified intervals is mandatory. Newly installed purchase cables should be detorqued after the initial 50 landings (no more than 60) and every 200 landings thereafter.

WARNING

Keep hands free of spinning parts when releasing torque from cables.

Purchase cable torque can be removed in the following ways. During flight operations, disconnect one side of the crossdeck pendant at the completion of an arrestment and partially retract the engine. This allows the cables to untwist. If time allows, blow the engine down to 200 psi and pull the engine out to its full stroke; disconnect one side of the crossdeck pendant; and retract the engine slowly to approximately 20 feet out of battery.

If torque buildup is greater than normal, it is recommended that the crossdeck pendant be discon-

nected from both topside terminals to allow a more efficient detorque of the cable system.

Preparing Cable and Terminal for Pouring

When working around an arresting gear engine, make sure the arresting engine retracting system is depressurized before performing any of the following steps involving the handling of the wire rope.

Preparing Wire Rope

When it is necessary to cut the wire rope, place two seizings of approximately 15 or 20 turns of soft steel seizing wire on the cable, approximately 1 inch apart. (See fig. 3-47, view A.) Cut the cable between the two seizings.

Remove the seizing from the cut end of the cable and, with the use of a marlinespike, unlay three strands of the cable. Using a pocketknife, cut and remove the hemp center a distance equal to the length of the terminal plus 1 inch. (See view B of fig. 3-47.) Re-lay the strands of the cable.

Make a seizing a distance equal to the length of the terminal plus 1 inch. The seizing should be made with the use of a serving tool and be 15 or 20 turns of soft steel seizing wire. (See fig. 3-47, view C.) Place two wraps of seizing wire immediately above the large seizing, as shown in view D.

Loop and tighten one or two turns of 0.047-inch-diameter copper wire on the end of all strands, as shown in view D. Using a marlinespike and tubing, unlay and straighten the strands of the cable to the top of the seizing. Pull the strands in toward the center to ensure a good distribution when the individual wires of each strand are straightened. (See view D of fig. 3-47.) After all the strands are straightened, remove the two turns of seizing previously placed at the top of the large seizing. Do NOT remove the large seizing; this seizing remains in place until pouring procedures are completed.

Do NOT use pliers to straighten the wires; pliers may damage or weaken the wires.

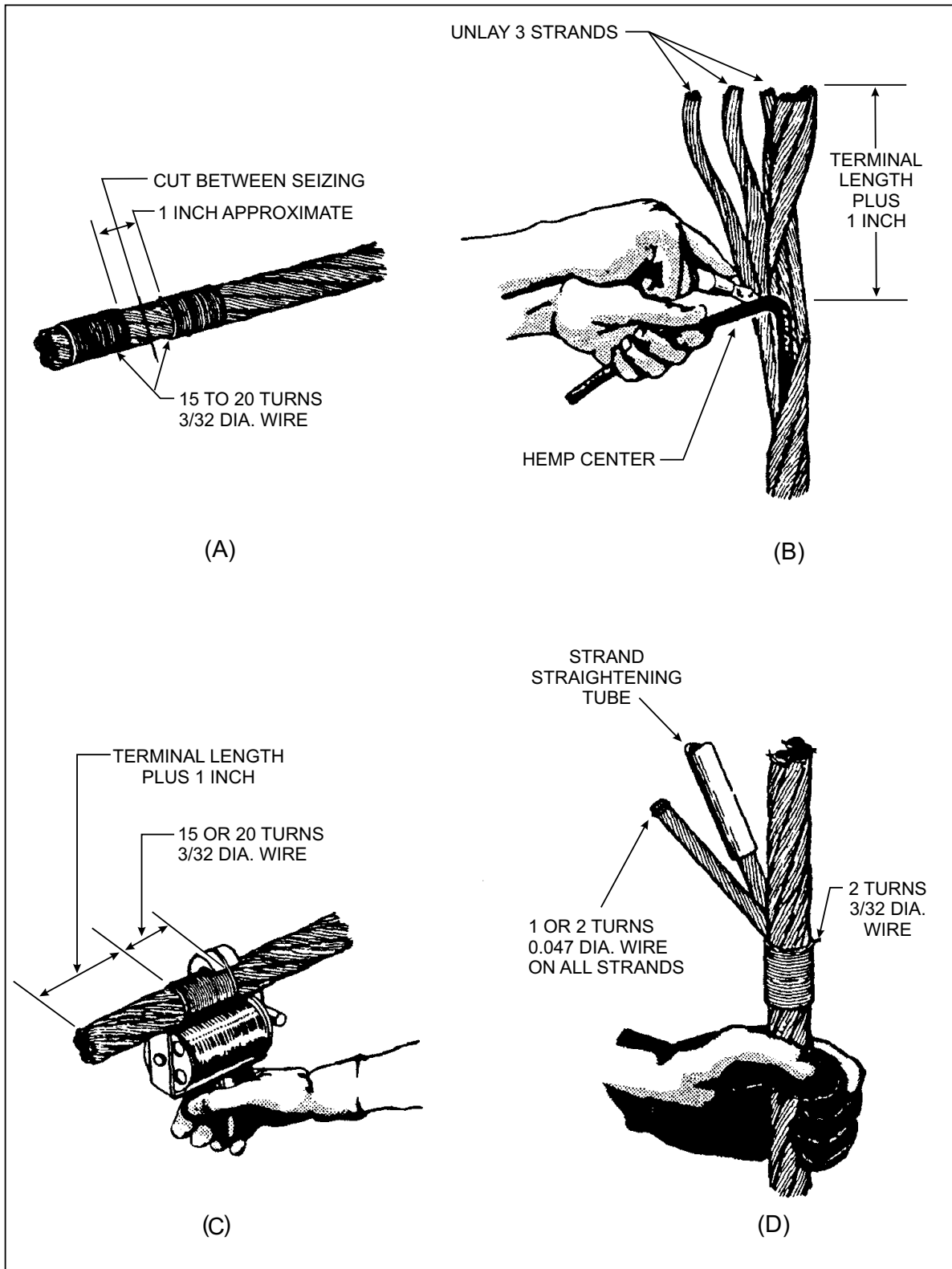

ABE0347

Figure 3-47.—Wire rope preparation.

Make certain that the large seizing is tight; remove the copper wire seizing from one strand at a time, and straighten the individual wires, using the power straightening device, shown in figure 3-48.

Repeat the straightening procedure on each strand, working on one strand at a time, until all the wires are completely broomed out as shown in figure 3-48.

Cleaning Wire Rope and Terminal Pouring

The cleaning and preparation of wire rope and terminals requires the use of chlorinated degreasing solvents, grit blasting, and the heating and melting of zinc.

WARNING

Personnel cleaning wire rope and pouring terminals must use chemical respirators and

make sure the area is properly ventilated. For complete safety procedures concerning zinc terminal pouring and wire rope preparation, consult the current arresting gear NAVAIR operation, maintenance, and overhaul instructions.

In a well-ventilated space, prepare the ultrasonic degreaser unit by filling it with GRISOLVE PEG-2, to within 1 inch of the tank top. The ultrasonic degreaser must then be energized for 2 hours before degreasing operations begin; this degasses and removes oxygen from the solvent, which increases its cleaning ability. One hour before the degreasing operation is to start, turn on the ultrasonic unit's heaters to heat the GRISOLVE PEG-2 to a temperature of 90 to 100°F. A stainless steel bucket (14-quart) will also be filled with 3 gallons of GRISOLVE PEG-2; this is used to rinse the broomed cable end after it has been cleaned in the ultrasonic degreaser unit.

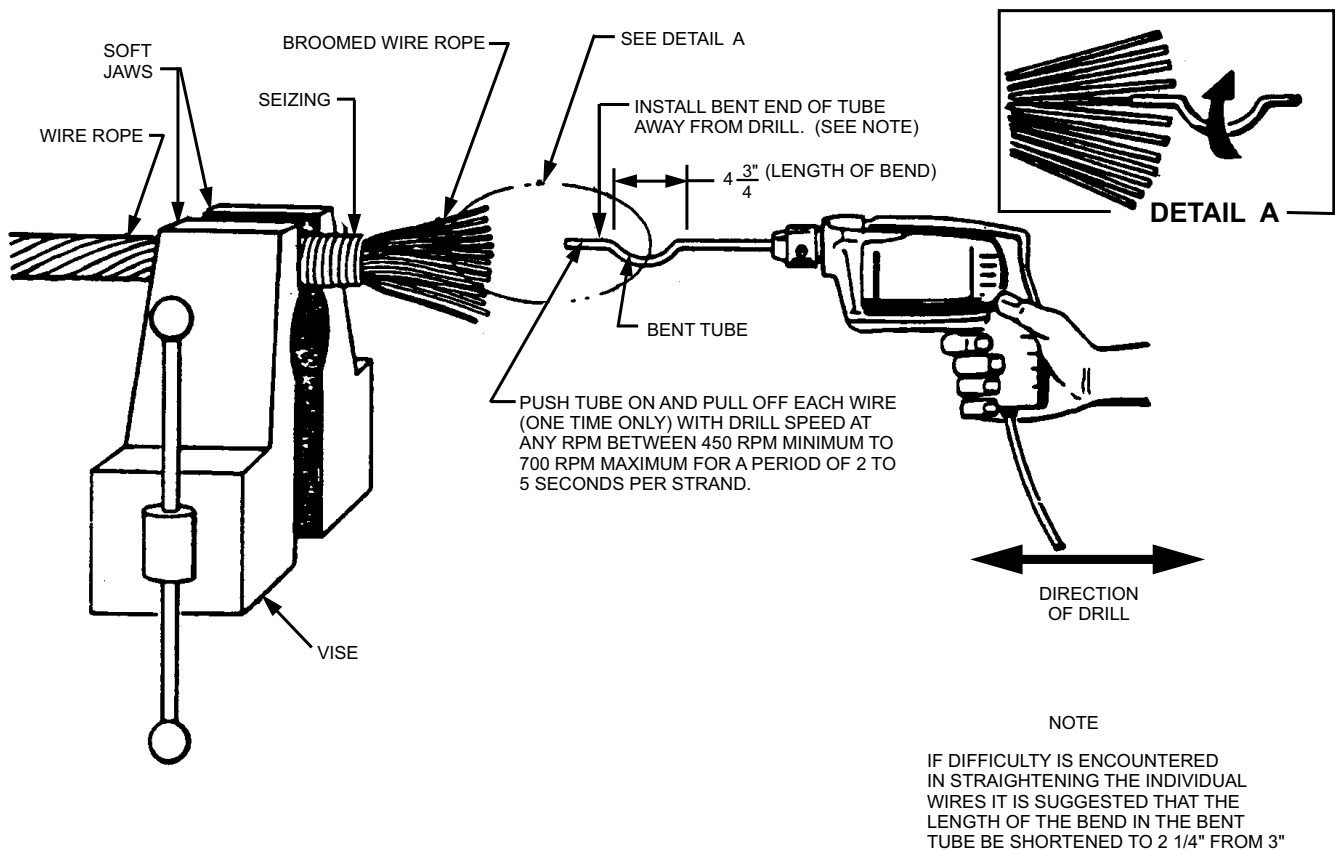
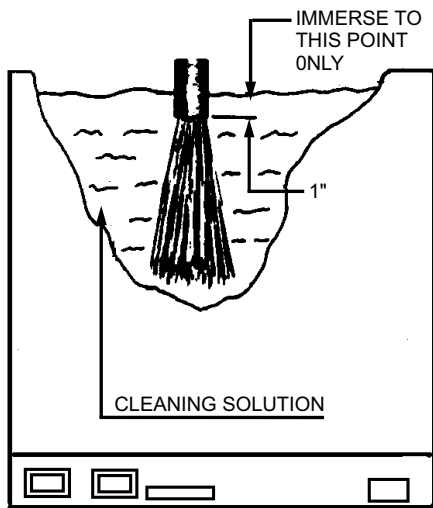

Figure 3-48.—Straightening individual wires with power straightening device.

ABE0348



CLEANING SOLUTION



RINSING SOLUTION



(1) ULTRASONIC DEGREASER (P/N 521566-1). IMMERSE THE BROOMED WIRE ROPE IN DEGREASING SOLUTION, GRISOLVE PEG-2 OR IMPACT INDUSTRIAL, (REPLACE DEGREASING SOLUTION EVERY 10 USES.)

(2) RINSE BROOMED WIRE ROPE IN 14 QT CONTAINER FILLED WITH 3 GALLONS OF GRISOLVE PEG-2 OR IMPACT INDUSTRIAL DEGREASING SOLUTION.

(3) DRAIN AND AIR DRY FOR FIVE MINUTES IN DOWN POSITION.

ABE0349

Figure 3-49.—Cleaning broomed-out wires.

To degrease, immerse the broomed end and approximately 1 inch of the seizing into the solvent in the ultrasonic degreaser unit tank (see fig. 3-49).

- The cleaning solution must be changed after 10 uses.
- Replace the rinsing solution when it becomes cloudy.

After cleaning the broomed end, slowly lift it out of the solution, allowing it to drain over the tank. Now, rinse the broomed end in the bucket of clean GRISOLVE PEG-2 then remove it and allow it to air-dry for 5 minutes as shown in figure 3-49. After the broomed end has dried, inspect it to ensure that all dirt, grease, and all other foreign matter have been removed. If necessary repeat the cleaning/degreasing operation. Following degreasing, the cleaner residues must be rinsed from the wire broom. Heat a 3-gallon bucket of clean, potable water to a temperature of 160° to 200°F. Immerse the broom in the rinse bucket of hot water until half of the seizing is immersed. Allow the broom to rinse for 2 or 3 minutes, gently swirling the terminal to agitate the water. Remove the terminal from the water and shake off the excess.

Following the rinse, examine the broom for any preservative remaining on the wires, especially where wires touch. If preservative accumulations are still apparent, reimmerse the broom into the degreaser,

repeat this cycle using clean rinse water each time until the broom appear clean.

After the broomed out wires have been thoroughly cleaned, wrap the end of the wire rope with two longitudinal strips of pressure-sensitive tape for a distance of 2 feet, leaving the broomed out wires and 1/2 inch of the seizing exposed (fig. 3-50).

The method used in preparing wire rope and terminals for zinc-poured terminals includes a grit blast method for etching the cables and terminals prior to pouring.

The following steps are used in the grit blast method:

1. Fill the cabinet hopper with loose grit, 100 pounds minimum to 200 pounds maximum.
2. Install the applicable inserts in the cabinet, depending on the size of the purchase cable being cleaned.

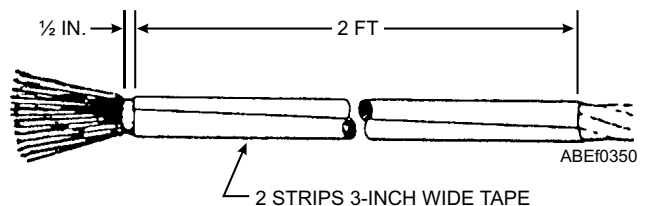

Figure 3-50.—Adhesive cloth tape applied to wire rope.

- Open the door of the grit blast cabinet by holding two thumbscrews and lifting. Place the prepared end of the wire rope into the grit blast cabinet to a convenient working location. Support the wire rope externally so that it enters horizontally. Secure the door with the wire rope in position. The wire rope should fit snugly. If the inserts used do not effect a snug fit, apply tape or cloth to that area of the wire rope.

An 80-100 psi dry-air source must be connected to an air filter located in the grit blast cabinet. Turn on the air source when ready to blast the wire rope.

- With hands in the gloves of the cabinet, grasp the blasting gun in one hand; and with the other hand, hold the siphon tube 1 inch or more below the surface of the grit. See figure 3-51.
- Blast the broomed-out wires with the gun nozzle tip 1/4 inch away from the wires. Use a back and forth motion over the entire length of exposed broomed-out wires, from the top of the wires to the bottom of the wires. Continue until a dull nonreflective surface appears on the wires. Rotate the wire rope 90°, using the applicable twisting wrench. See figure 3-52.

NOTE: If during the grit blast operation the gun becomes clogged, it may be necessary to sift foreign matter from the grit. This is accomplished by using a sieve furnished with the grit blasting cabinet.

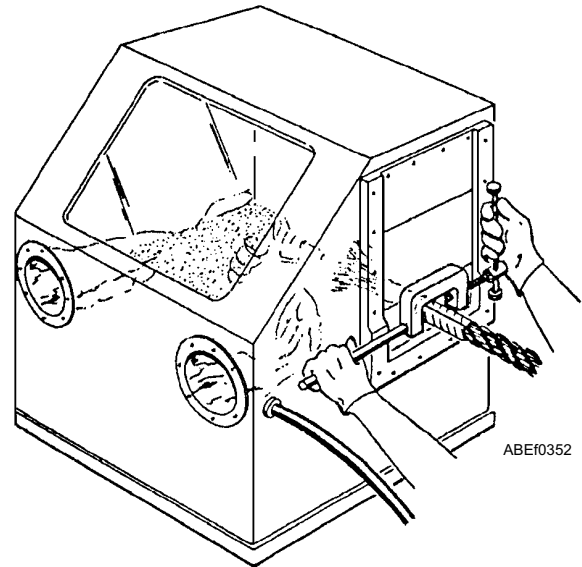

Figure 3-52.—Rotating the cable in the grit blast cabinet.

- Repeat the process until the entire exposed area of wire rope has been grit blasted. Finally, direct the nozzle into the open end of the broomed-out wires at about 30° from the longitudinal, and rotate the wire rope slowly through 360° while blasting with a circular motion. See figure 3-53. Remove the wire rope from the cabinet and inspect it for completeness of grit blasting. Any evidence of shine will indicate a need for additional grit blasting. After being grit blasted, the wires should not be touched with hands, rags, gloves, and so on, or the cleanliness required for sound terminals will be impaired.

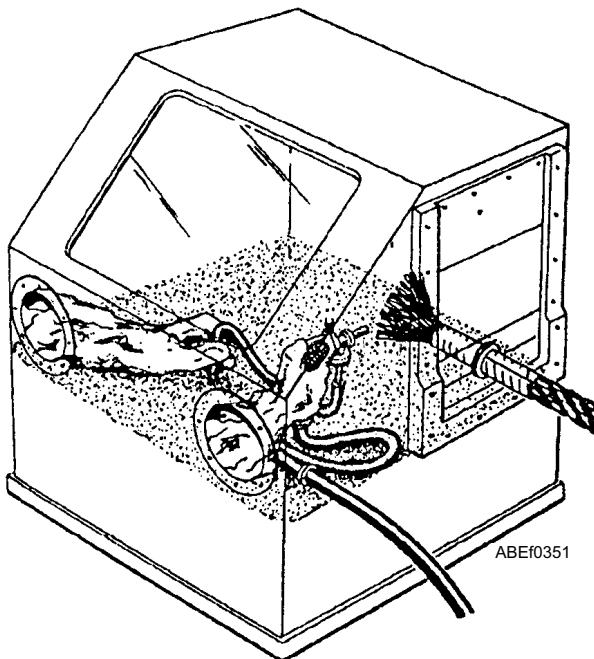

Figure 3-51.—Grit blasting of wire rope.

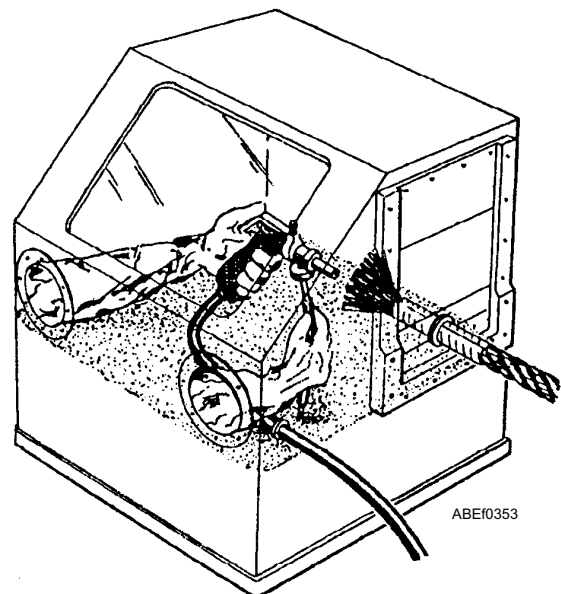
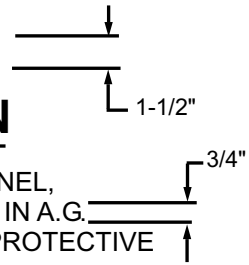

Figure 3-53.—Blasting inner wires.

WARNING-DANGEROUS AREA PROVIDE ADEQUATE VENTILATION

WHEN POURING TERMINALS, ONLY AUTHORIZED A. G. PERSONNEL, FOLLOWING THE PROPER POURING INSTRUCTIONS OUTLINED IN A.G. MANUALS AND LATEST BULLETINS, AND WEARING SPECIFIED PROTECTIVE GEAR, ARE PERMITTED IN POURING ROOM/AREA.



AMEf0354

Figure 3-54.—Safety placard for terminal-pouring rooms.

7. Shake the wire rope vigorously, broomed-out end down, to remove any grit between the wires or in the hemp center. Only air from the cabinet supply is used to remove grit; do NOT use any other source, because other sources may be contaminated with oil or water.
8. Remove the grit-siphon tube from the grit supply, and air blast the wire rope to remove the remaining grit.

NOTE: After grit blasting a total of 15 broomed-out ends, drain off 10 pounds of used grit from the bottom of the hopper and replace it with 10 pounds of new grit.

9. Remove the tape from the wire rope.
10. Prepare a solution and flux the wire rope.

Fluxing

For solution preparation and fluxing, the following procedures are used:

1. Heat the pre-mixed solution until the temperature is between 160 and 210°F, using the hotplate provided. Measure the temperature of the solution with the bimetallic thermometer. Allow the solution to remain at this temperature for 5 minutes, then remove it from the hotplate and allow it to cool to room temperature.
2. Remove any scum or foreign matter from the surface of the cooled solution with clean napkins or wiping towels. Do NOT agitate the solution during this operation.
3. Carefully pour the clear, cooled solution into another stainless steel container. Avoid pouring any foreign matter into this container. If the hot-air drying method is used, the solution can

be used cold. If the cable is to be dried by natural air, use the procedures listed in step 4.

4. Heat the clear flux solution until the temperature is between 160 and 210°F. Immerse wires carefully so the flux solution does not enter the core of hemp-center-type wire rope.

WARNING

Do NOT flux wire rope terminals.

5. Immerse the grit-blasted wires in the solution to within 1 inch of the top of the seizing for 5 minutes.
6. Remove the wire rope from the solution, shake, and turn the broomed end upright at once. Then allow it to dry for 5 minutes. Any evidence of rust on the wires after the flux-dry period will necessitate refluencing.

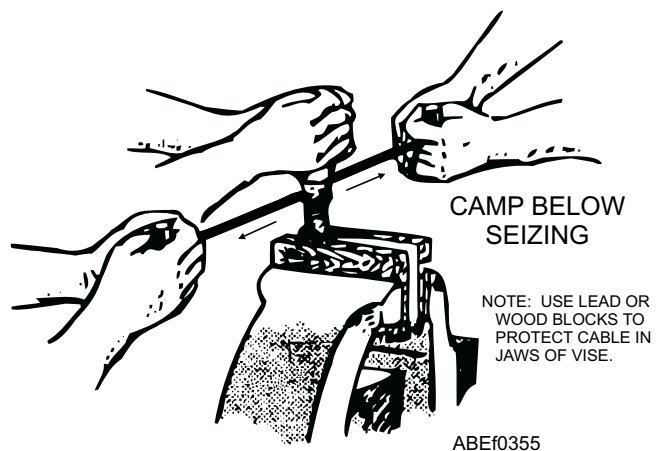

ABEf0355

INSTALLING TERMINAL ON BROOMED
END OF WIRE

Figure 3-55.—Installing the terminal.

Preparing the Terminals

Using a degreased length of seizing wire, suspend the terminal from the top of the ultrasonic degreaser so it is submerged in the solution. Inspect the terminal and repeat the procedure if necessary. Rinse the terminal in a bucket of clean GRISOLVE PEG-2 for 30 seconds, then let air-dry for 5 minutes.

Replace the solution in the ultrasonic degreaser after 10 terminals have been cleaned/degreased. Replace the rinsing solution after 10 terminals have been rinsed or as soon as the solution becomes cloudy.

Lay the terminal in the grit blast cabinet. Plug the cable entry hole with the rubber plug hanging from the cabinet. Secure the doors on the side. Grit blast the internal surfaces of the terminal from both ends. Rotate the terminal so that the entire internal surface is blasted.

Remove the terminal, invert it, and shake it thoroughly to remove residual grit.

To keep arresting gear crews constantly aware of the health hazards associated with the present terminal pouring procedures, safety warning placards, fabricated by ship's forces, will be posted in clearly visible locations in the arresting gear terminal pouring rooms/area. (See fig. 3-54.)

Preparing and Pouring Zinc

Make certain to use the special high-grade zinc ingot (NAEC PN323822-2), which comes in two-pound slugs. Personnel engaged in preparing and/or pouring molten zinc must wear protective clothing, such as goggles and gloves. A protective screen must be provided around the pouring station.

A ladle and heating furnace are used to melt the zinc. Use a ladle that is thoroughly dry and free from rust, scale, slag, or any other foreign matter. Place a minimum of five pure zinc ingots into a clean ladle.

The zinc must be heated to a range of 950 to 1,000°F for pouring. The temperature may not exceed 1,075°F. Discard zinc that has been heated above 1,075°F. Measure the temperature frequently with a portable pyrometer. Preheat the ladle prior to immersing it in the molten zinc.

Clamp the wire rope vertically, below the seizing, in a vise having copper- or lead-protected jaws. The wire rope should be clamped sufficiently tight to hold the wire firmly but not so tight as to deform the lay.

Attach wooden handles to each end of a length of soft steel wire that has been cleaned in the same way as the broomed-out cable and terminal. Loop this wire once around the broomed-out wires. Pull the wire to tighten the loop, and compress the broomed-out wires together. See figure 3-55. Do NOT touch broomed-out wires with greasy rags or hands.

Start the terminal on the compressed wires and slide it onto the wire rope until the bottom rests on the seizing. See figure 3-55.

Reclamp the wire rope in the vise in a vertical position. Make sure the terminal is not tilted in any way.

Degrease and secure two turns of copper wire around the broomed-out wire rope, 1/2 inch beyond the top of the terminal. Draw the broomed-out wires inward and away from contact with the terminal so that there is approximately 1/16-inch clearance between the wire and the inner wall of the terminal.

Wet a roll of plaster of paris bandage in lukewarm water and squeeze out the excess water. Wrap the plaster of paris bandage around the base of the terminal at a distance of about 4 inches. Press the bandage firmly to the contour of the terminal and wire rope. (See fig. 3-56.) Dampen a textile cloth with water and wrap it

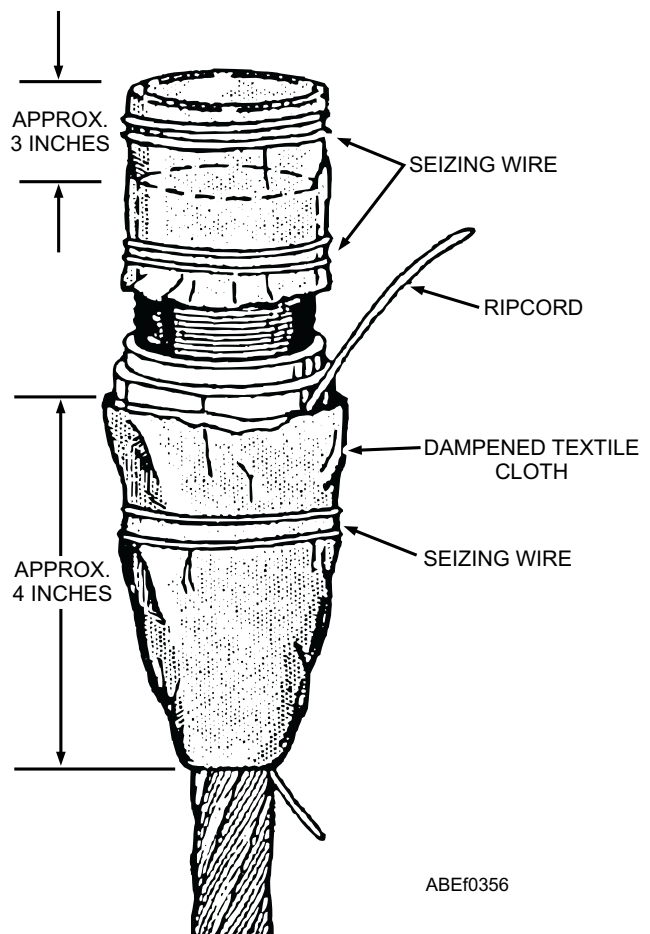

ABE0356

Figure 3-56.—Textile cloth applied to the terminal.

around the plaster of paris and secure it with seizing wire. The textile cloth may extend far enough to protect the wire rope from the torch while the terminal is being heated.

Heat the terminal carefully and uniformly with the torch, making certain the flame is not directed on the exposed wire rope at the bottom of the asbestos cloth. (See fig. 3-57.) Continue heating the terminal until it begins to radiate heat waves. Remove the torch from the terminal and leave the terminal undisturbed for 30 seconds. Make a mark on the thickest portion of the terminal with a 550 and 600°F Tempilstik. Repeat this at four areas, 90 degrees apart, to ensure an average temperature.

The zinc should be at the proper temperature at this time so that the pouring can take place when the terminal is heated to the correct temperature. Do NOT attempt to measure terminal temperature with the portable pyrometer.

If the 550°F Tempilstik leaves a wet mark and the 600°F Tempilstik leaves a chalk mark at the four areas, pour the zinc immediately. If the four areas show a wet mark for both the 550 and 600°F Tempilstik, continue checking the four areas every 20 seconds until the 600°F Tempilstik leaves a chalk mark and the 550°F Tempilstik leaves a wet mark; then pour the zinc immediately.

If the temperature has fallen below 550°F (550°F Tempilstik leaves a chalk mark), reheat the terminal and proceed again as previously described.

Skim the dross (impurities) from the top of the molten zinc before pouring. Use the portable pyrometer to measure the temperature of the molten zinc and to determine, thereby, if the zinc has reached its proper temperature for pouring. (See fig. 3-58.) The temperature of the zinc must be accurately measured with a portable pyrometer.

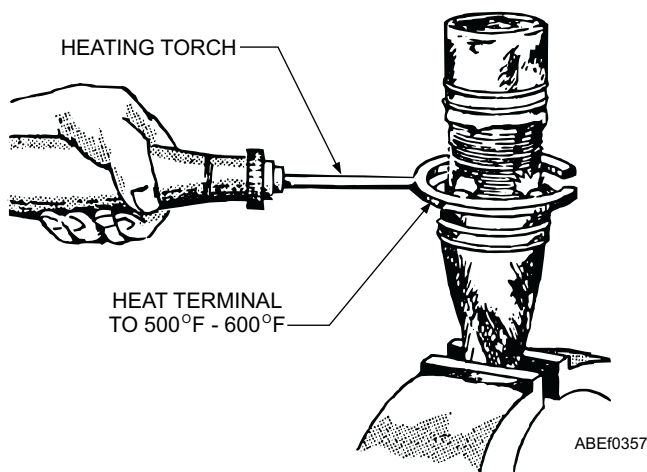

Figure 3-57.—Heating the terminal.

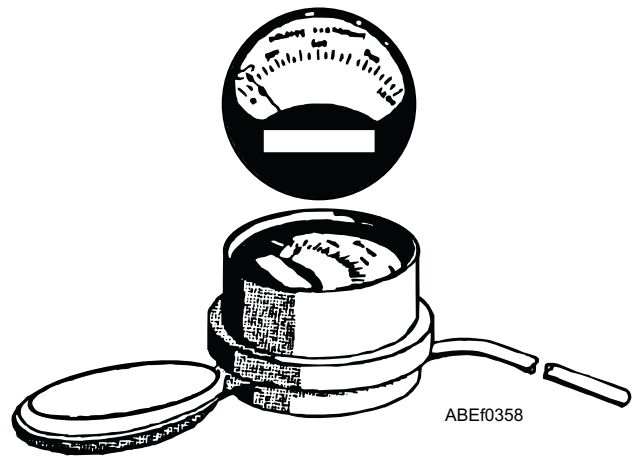

Figure 3-58.—Pyrometer.

Do not handle the portable pyrometer carelessly, because the millivoltmeter on it is a sensitive, precision instrument. When the portable pyrometer is not in use, keep it in the carrying case.

Measure the temperature of the molten zinc by holding the portable pyrometer in one hand and dipping the iron tube of the portable pyrometer in the molten zinc, being sure to keep the thermocouple in the center of the molten zinc and not touching the bottom of the pot. The temperature of the molten zinc will then be indicated on the portable pyrometer dial. Pour zinc at a temperature of 950 to 1,000°F.

Pour the zinc into the terminal. Fill it to within 1/2 inch from the top of the textile cloth to provide a sufficient "hot top."

Tap the sides of the terminal lightly with wooden sticks during and after pouring of the zinc, until a surface crust forms. See figure 3-59.

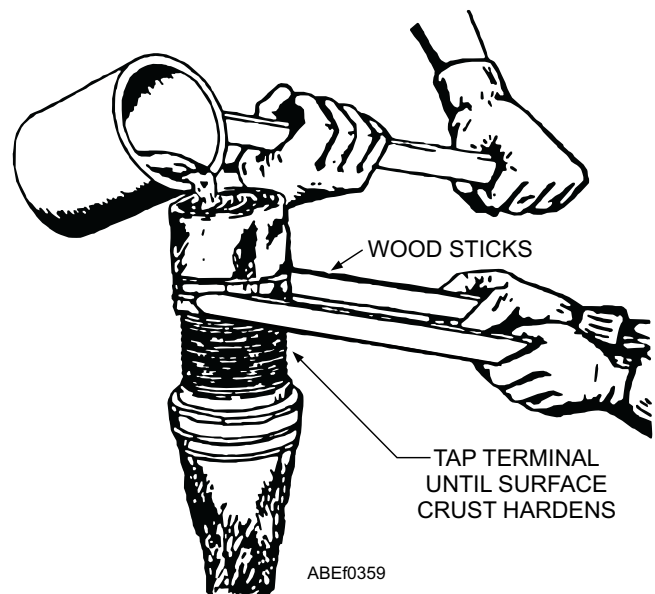

Figure 3-59.—Tapping the terminal during pouring.

Using a short piece of seizing wire thoroughly degreased, pierce the bubbles that rise to the surface of the hot top. Do not poke the wire into the zinc more than 1/2 inch. Skim the surface of the hot top with the end of the seizing wire to allow the gas bubbles to rise and be accessible for piercing.

After the zinc has solidified, allow the poured terminal to air-cool at room temperature for 30 minutes. During this time the zinc will harden. After the cooling period, proceed as follows:

1. Remove the textile cloth and plaster the terminal.
2. Pour 4 gallons of preservative oil into a clean 5-gallon metal container.
3. With the preservative oil at room temperature, immerse the entire poured terminal for 30 minutes. This will rapidly cool the terminal.
4. Immediately after the 30-minute oil quench period, remove the terminal and allow the excess oil to drain into the container.
5. Using the hot-top cutter assembly, cut off the hot top flush with the top of the terminal after the terminal has cooled (fig. 3-60).

Finishing and Inspecting the Terminal

Round off the sharp edges of the terminal with a file. File the zinc down to a smooth surface flush with the end of the terminal. Clean the terminal with a wire brush. Remove all traces of residual flux, plaster, and superficial rust (using the wire brush) from the wire rope for a distance of 6 inches from the base of the terminal. Chase the threads with an applicable threading die.

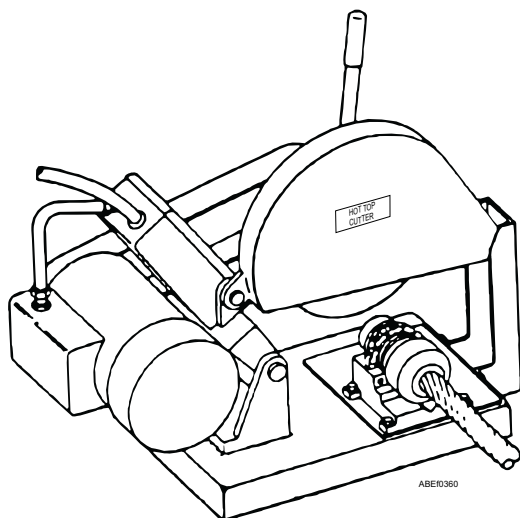
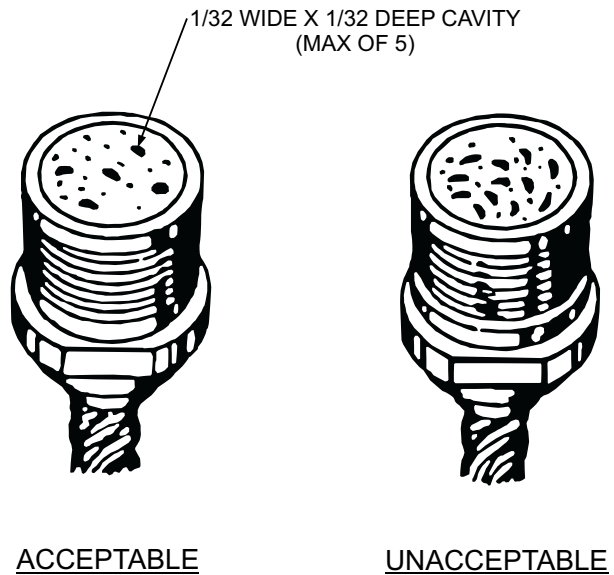

Figure 3-60.—Cutting the hot top.

Inspect the zinc face of the terminal for soundness of zinc and good wire distribution. The presence of any cavities in the face of the zinc indicates that the strength of the terminal is questionable. The criteria for acceptance of cavities are as follows:

1. A maximum of five cavities up to 1/32-inch wide and 1/32-inch deep scattered randomly over the zinc face. Figure 3-61, view A,



CONDITION A

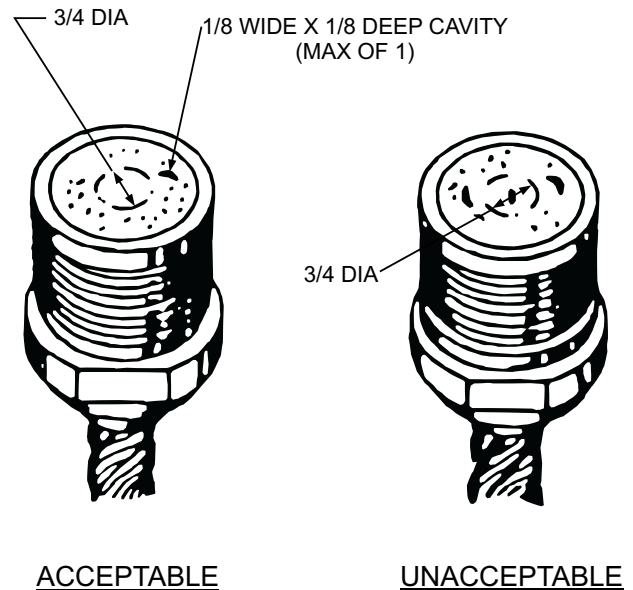

CONDITION B

Figure 3-61.—Inspection of zinc face.

ABE0361

illustrates an acceptable face. Crop and repour if six or more cavities are found.

2. A cavity up to 1/8-inch wide and 1/8-inch deep caused by breaching of several wires must NOT be in the center of the zinc face within the area of 3/4-inch diameter. An acceptable face is shown in view B. A 1/8-inch cavity by 1/8-inch cavity caused by any other factor than breaching wires is not acceptable. This breaching is several wires coming together at the surface, which does not permit the zinc to fill the area. These allowable cavities are the result of pouring, and not that of a pull test.

Inspect around the base of the terminal for a penetration of zinc. This penetration must be present to have an acceptable terminal. It is also a good indication

of a well-poured terminal. The wires of the strands of the wire rope below the terminal must not show any deformity due to having been held too tightly in the vise during the pouring and finishing operations.

Testing the Terminal

During an arretment, the wire rope system must take a very high impact load; therefore, all fittings of the system must be carefully poured. It is imperative that the fitting be strong and well made. To determine their condition and strength, the terminals must be tested for soundness of the poured joint.

Terminals poured by a naval activity or by personnel aboard ship are tested for reliability. The cable terminal proof-loading machine is a self-

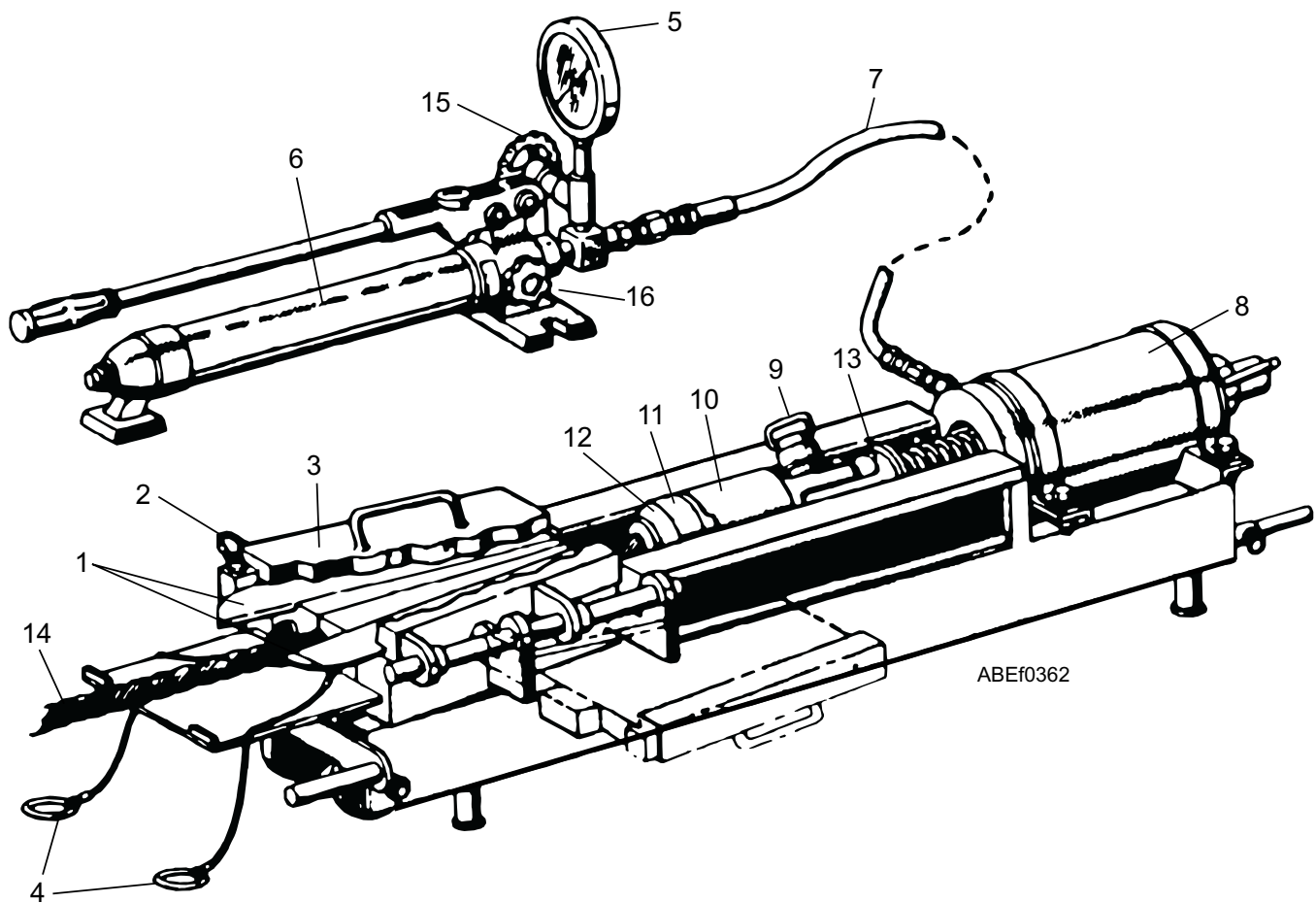

ABEf0362

- | | |
|------------------------|---------------------------------|
| 1. Wedge set | 9. Connecting pin |
| 2. Safety lock pin | 10. Clevis socket |
| 3. Grip assembly lid | 11. Lock ring |
| 4. Retracting cables | 12. Cable terminal |
| 5. Tension gauge | 13. Tension rod |
| 6. Hand hydraulic pump | 14. Purchase cable |
| 7. Hose assembly | 15. Needle valve |
| 8. Ram (cylinder) | 16. External load release valve |

Figure 3-62.—Wedge-type proof-loading machine (single ram).

contained hand-operated unit designed specifically for proof loading poured terminals on both deck cables and purchase cables.

Cable Terminal Proof-loading Machine

The cable terminal proof-loading machine is capable of providing a test load that substantially exceeds the test load required for testing the reliability of terminals used by ABEs. The test load is read on the tension gauge, which is calibrated in pounds, and is positioned in the line leading from the pump to the ram (see figs. 3-62 and 3-63).

The machine operating procedure is as follows (refer to fig. 3-63).

1. Thoroughly clean the portion of cable (19) that will be in contact with the wedge set (1) during the test. Do NOT use solvent for this cleaning operation.

2. Relieve all pressure in the hydraulic system by cracking open the external load-release valve (21) to slowly release the proof-load on the gauge. Slowly releasing the gauge load will prevent rapid snapback, with resultant possible breakage of the gauge pointer.
3. Manually move the crosshead away from rams and install the crosshead terminal.
4. Remove the safety lock pin and slide the lid toward the cylinders to open.
5. Install the wedge set, Lucker Manufacturing Company Part No. 3130-143 (for testing 1 7/16-inch-diameter purchase cable). Do not lubricate the cable gripping surface or the lid sliding surface.
6. Retract the wedges by pulling on the retracting cables. Lubricate the wedge sliding surfaces with PRELUB-6 before each test.

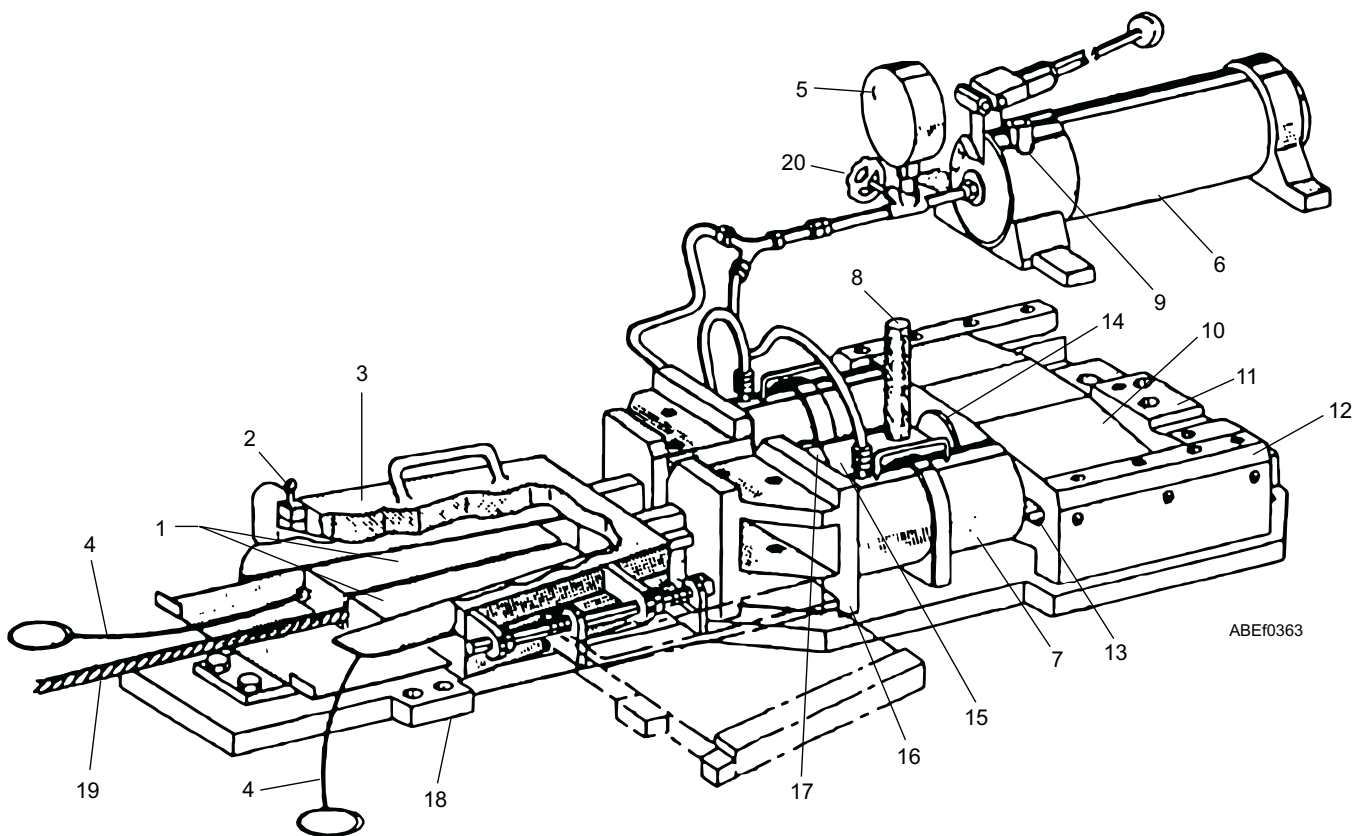

- | | |
|------------------------|---------------------------------|
| 1. WEDGE SET | 9. CONNECTING PIN |
| 2. SAFETY LOCK PIN | 10. CLEVIS SOCKET |
| 3. GRIP ASSEMBLY LID | 11. LOCK RING |
| 4. RETRACTING CABLES | 12. CABLE TERMINAL |
| 5. TENSION GAUGE | 13. TENSION ROD |
| 6. HAND HYDRAULIC PUMP | 14. PURCHASE CABLE |
| 7. HOSE ASSEMBLY | 15. NEEDLE VALVE |
| 8. RAM (CYLINDER) | 16. EXTERNAL LOAD RELEASE VALVE |

Figure 3-63.—Wedge-type proof-loading machine (dual ram).

7. Screw the clevis socket on the cable terminal.
8. Place the cable between the wedges and connect the clevis socket to the crosshead terminal with the pin.
9. Manually move the crosshead into the rams, making certain that the adapter attached to each end of the ram engages its respective guide hole in the face of the crosshead.
10. Release the wedges, close the lid, and insert the safety lock pin.
11. Using chalk, masking tape, or some other means, mark the cable a measured distance from the wedge set. This procedure provides a means for checking cable slippage while the system is being pressurized.
12. Visually inspect the socket tester to make certain that all components are securely attached. Do not open the choker valve during operation of the hand pump, as this will result in excessive pressurization of the socket tester after the desired proof-load has been reached.
13. Open the choker valve (20) on the hand pump, and close the external load-release valve. Never apply proof-loading with the lid open, and keep hands clear of pin and crosshead area.
14. Using the hand pump, pressurize the system to increase the test load to 120,000 pounds. Hold the test pressure for 2 minutes.
15. As the pressure is gradually increased, observe the cable for evidence of slippage. If the cable begins to slip, proceed as follows:
 - a. Relieve the pressure as in step 2.
 - b. Remove the safety lock pin and open the lid. It may be necessary to first strike the lid with a soft mallet before it can be slid forward to open.
 - c. Retract the wedges.
 - d. Remove the cable and clean it thoroughly.
 - e. Clean and inspect the wedge gripping surfaces. Replace the wedges if necessary.
 - f. Lubricate the wedge sliding surfaces.
 - g. Repeat proof-loading procedures
 - h. Remove the cable from the socket tester and examine the poured terminal.

REPLACING PACKINGS

The efficiency of any hydraulic equipment is directly dependent on the proper selection, preparation and installation of its packing. The replacement packing shall be only those that are called out in the assembly parts list. No substitutes or deviation in size or number shall be made. Prior to installation, the age of natural or synthetic rubber packing shall be checked to determine whether these parts are acceptable for use. A positive identification indicating the source, cure date, and expiration date shall be made. This information shall be available for all packing used.

The age control of all natural or synthetic packing shall be based upon the "cure date" stamped on the manufacturer's unit package, intermediate package, and shipping container. The cure date means the date of manufacture and is designated by the quarter of the year and year of manufacture. The cure date forms the basis for determining the age of the V-ring, O-ring packing, therefore, it becomes important that the cure date be noted on all packages. Packing manufactured during any given quarter will be considered one quarter old at the end of the succeeding quarter. For the purposes of explaining the coding used by manufacturers to designate the cure date, each year is divided into quarters as follows:

- First quarter: January, February, March
- Second quarter: April, May, June
- Third quarter: July, August, September
- Fourth quarter: October, November, December

The shelf-life control of all packing shall be governed by the "expiration date" stamped beside the manufacturer's cure date on each package. The expiration date is the date after which packing **CANNOT BE USED IN-SERVICE**. Synthetic and natural rubber packing and V-rings shall have a shelf-life limit of three years (12 quarters). Synthetic and natural rubber O-rings shall have a shelf-life limit of five years (20 quarters). Fluorocarbon O-rings, M83248/1-, have a shelf-life of twenty years (80 quarters). Thus, packing and V-rings shall be scrapped if not put into service within three years after the cure date, and O-rings shall be scrapped five years (twenty years for fluorocarbon O-rings) after the cure date. All packing shall be scrapped if not put into use before the time of the expiration date.

Removing Old Packings

If practical, remove the shaft, ram, or other sealed members from the installation, since this permits inspection and correction of any defects in the shaft or packing assembly. Although it is preferable to remove the sealed member, limitations of time, design of the installation, or problems of reassembly often make the removal impractical. After the gland or flange is removed, the chief problem usually encountered is removing the female adapter. If this ring is provided with holes, insert a suitable hoop of bent and flattened wire, or a threaded rod if the holes are tapped, and pull the ring back along the shaft. The packing can be removed using a U-shaped pick made of copper or brass wire. The pick should be small enough to enter the stuffing box, and the ends should be bent and flattened. The pick should be inserted behind the ring, and the ring removed. It is usually not necessary to remove the male adapter. If the adapters are not provided with holes or if removal is difficult, they may be removed by alternate methods, such as inserting a wire or piece of flat stock behind the adapter and pulling it out (if sufficient space exists), or by bumping the shaft or stuffing box to dislodge the adapter. All traces of the packing must be removed and the stuffing box cleaned and inspected for scratches, burrs, or sharp edges. Rough spots or sharp edges must be honed down with a fine Carborundum stone. It is usually not necessary to replace the metal support rings or adapters when packings are replaced unless inspection shows failure, defects, or excessive wear.

Installing New Packings

A V-ring packing housing generally consists of male adapters and female adapters. Either or both of the adapters may be designed as part of the gland or stuffing box. The adapters position and support the V-rings and form an efficient seal only when pressure spreads the lips of the rings firmly against the shaft, ram, or piston and against the walls of the stuffing box. To function properly, the female (open) side of the rings must face the pressure.

In double-acting installations, two opposing sets of packings are used with the open sides of each set facing away from each other. The female adapter must be inserted into the stuffing box first and seated properly. Each packing ring must then be inserted individually. Each ring must be seated carefully before the next ring is inserted. The rings must be seated with the aid of a flat tool or stick. To eliminate air trapped between the

rings as they are being inserted, collapse a short section of the ring by placing a thin rod of brass or other soft metal between the lips and the stuffing box wall. The male adapter, if used, must then be properly seated.

Extreme care must be exercised on installation to insure that the rings are not forced over sharp edges. A light coating of petrolatum conforming to the proper specification may be used if necessary, but excessive use must be avoided. Care is also taken that the rings or stuffing box wall is not damaged in any way.

Gland Installation

Some of the packings of the engine may be spring-loaded. No gland adjustment is necessary on this type, since the springs normally allow sufficient float of the packing. If the gland is other than spring-tensioned, insert the gland and apply easy hand pressure until the gland touches the packing. Do not force it. If there is clearance between the flange of the gland and the body surface, withdraw the gland and insert one or more gaskets with a total thickness of from 1/64 to 3/64 inch greater than the distance between the gland flange and body surface. If there is metal-to-metal contact between gland flange and body upon application of hand pressure, the gland must be removed and the depth of the stuffing box must be measured. The length of the gland from the inner face of the flange to the surface that contacts the packing must be measured. This length must be subtracted from the depth of the stuffing box; if the difference exceeds 3/64 inch, a shim of the thickness of the excess must be removed or the gland flange must be machined to take up the excess. If the gland is the screw-in type, the procedure is the same except that the gland must be screwed in until contact with the packing is made and then backed off sufficiently to give a minimum of 1/64-inch and a maximum of 3/64-inch clearance between the gland and the packing. The amount of backup may be determined by counting the number of gland nut threads to the inch. For instance, if there are 10 threads to the inch, one revolution of the gland will give 1/10-inch clearance. If possible, the gland nuts should be lock-wired to prevent rotation.

General Precautions Regarding V-Ring Packing

If leakage appears at the V-ring packing joint, check the gland flange for metal-to-metal contact with the body. Rework or replace parts as necessary, and if leakage continues, remove and examine the packing for damage or wear. A small leakage or "weeping"

generally appears when a V-ring packing has been replaced, but it usually ceases after operation. If leakage persists after operation, the packing may have unseated itself and the gland should be readjusted. If leakage persists after a reasonable adjustment, disassemble and check the stuffing box walls and the pistons for scoring, and check the packing for damage. Leaking packing must be replaced when adjustment does not stop the leakage. Excessive gland pressure must not be applied. V-ring packing under pressure from the gland not only functions improperly or wears out faster but also applies uncalculated forces on the ram, shaft, or piston, which may cause improper operation of the machinery. A clearance of 1/64 to 3/64 inch must be maintained to allow the packing freedom of movement. When there is clearance between the body and the gland flange, check the clearance at four points, 90° apart, to ensure that the packing or gland is not cocked before installing the gasket.

REVIEW QUESTIONS

- Q13. What is the minimum allowable clearance between the crosshead and the crosshead stop?*
- Q14. What is the age of all packing based on?*
- Q15. What is the shelf life of V-ring packing?*
- Q16. When installing V-ring packing, what side faces the pressure?*

SAFETY PRECAUTIONS

LEARNING OBJECTIVES: List the safety precautions associated with topside and deckedge areas. List the safety precautions associated with the arresting engine below decks. List the safety precautions associated with maintenance of aircraft recovery equipment.

Safety is not an accident. Safety is the result of trained personnel knowing their jobs and doing those jobs to the utmost of their ability. Attention to every detail, concern over every function, and awareness of malfunction will nullify the possibility of accident from improper operational procedures. Mechanical failure cannot be completely neutralized, but trained personnel can make such a failure a rarity.

Recovering aircraft involves various inherent dangers, due to the complex coordination of personnel and machinery. Personnel engaged in the operation of the arresting gear equipment must be thoroughly

trained and indoctrinated in the operations. Disregard for the fundamentals of caution and safety creates hazards far in excess of the previously mentioned inherent danger factors.

All operating personnel must understand the importance of accurate commands, attention to commands, and proper care of communications systems. The system may be phones, synchro signals, or lights, and must be operational at the time of use. Accuracy in making proper settings of gears, indicator systems, tension, and pressure tests must be emphatically impressed on all personnel.

The following general safety observations are arranged according to location, and copies should be supplied to all applicable stations.

TOPSIDE AND DECKEDGE AREAS

During arrestment, all topside and deckedge personnel should be aware of all movement on and about the deck, with strict attention paid to the landing aircraft. Deckedge control operators should duck below deck level during pendant arrestment in the event of pendant breakage or failure that would cause cable whip or the aircraft to go over the deck edge.

Hook Runners

Hook runners should approach aircraft from the front and side. This will place them away from danger of jet blast or broken cable backlash.

Overcrowding

Catwalk personnel should be held to a minimum so they can exit quickly should they be placed in jeopardy.

Barricade Readiness

Rapid fuel consumption by jet aircraft requires highly trained, responsible crews for rigging the barricades. Regular drills in rigging should be held to reduce rigging time to a minimum.

Walkback

Air in the main engine cylinder or the CRO valve does not seat properly are the major causes of walkback. This is an extremely dangerous occurrence, as the pilots have no control over the aircraft in addition to being unable to see where they are going, thus the aircraft may go overboard, endanger deckedge

personnel, or cause injury to personnel on deck not paying attention to what is happening around them.

Pendant Retraction

The retracting cycle of the deck pendant is normally executed at full speed. The operator, prior to pulling the retracting lever, must ascertain that no personnel or equipment are in a position to be struck during retraction. If for any reason a sudden interruption of the retracting cycle occurs, the same precaution must be taken prior to the resumption of the retraction cycle.

Wire Supports

Broken or deformed wire supports should be replaced as soon as practical.

Stanchions

Personnel should stay clear of areas where stanchions are being raised or lowered, and particularly when barricades are being raised or lowered. When stanchion repair is to be effected, the stanchions safety brace must be installed.

Terminals, Fittings, and Cables

Frequent inspection of all cables, terminals, and fittings should be maintained. Any indication (no matter how slight) of failure should be corrected immediately. Particular attention should be given to terminals jamming sheaves. Any condition where this is evident is extremely critical. The unit involved should not be operated until correction of the condition is made.

Sheaves and Winches

Generally all sheaves should be free running, have no indication of turning of the lips, or indication of jamming by terminals. No slippage of the sheave on races should be evident, and any fault of this nature should be corrected. Winches should be checked for running and positioning. Both sheaves and winches should be kept clean of debris or foreign matter, and be regularly lubricated.

BELOW DECKS—THE ARRESTING ENGINE

The greatest safety factor in the operation of the arresting engine is constant attention to inspection, maintenance, and overhaul. Preventive maintenance is

particularly necessary. Daily inspection, inspection after each arrestment, and depending on the unit involved, inspection and maintenance at regular intervals nullify many of the conditions that might arise to endanger operating and flight personnel. Always keep hands and body clear when engine is operating or in a condition to become operable.

Weight Selector Settings

The safe arrestment of incoming aircraft can be directly attributed to proper setting of the aircraft weight selector. Aircraft weight selector settings should always be made according to current aircraft recovery bulletins. Maximum efficiency is obtained from the arresting engine through proper weight settings. There is one distinct error in arrestment that can be directly attributed to improper weight settings or error in the gross weight estimate. This error results in TWO-BLOCKING the engine.

TWO-BLOCKING is a condition in which the weight selector is set too light for the incoming aircraft. This condition causes the ram to ride forward into the cylinder until the crosshead bangs into the mouth of the cylinder. A wooden block assembly, called a ram block, is positioned at the crosshead end of the ram to act as a shock absorber by preventing metal-to-metal contact between the crosshead and the mouth of the cylinder.

BOUNCEBACK is the movement of an arrested aircraft backward and is caused by the stretch inherent in the purchase cables. Bounceback is desirable because the hook is disengaged, allowing rapid deck clearance for future landings. Pilots are instructed to allow for bounceback before braking.

Control Valve Failure

Prime failure, with resultant disastrous consequences, could be failure of the drive system that would result in improper opening or closing of the CRO valve. Cam alignment is equally important, as improper alignment would result in fluid flow through the CRO valve at a ratio different from that indicated on the aircraft weight selector indicator. Thus, while the operator would have an indication of a proper setting, actual flow control would be different.

Drive System Hazards

Much of the cable system is contained behind U-channels to protect personnel during operation. This cable, with connections, is subject to wear and fatigue

and should be checked against failure. Failure of the drive system could cause serious injury to operating and aircraft personnel.

Excessive Pressures

The accumulator is built to take a 400-psi initial charge and such additional pressure as is developed during arrestment. This capacity provides for an overloading factor. However, it is most important that the accumulator blow-down valve on the charging panel be kept open. Should leakage occur from high-pressure piping as the result of inadequate valving, this, with the additional compression loading during arrestment, could cause an extremely dangerous accumulator pressure. One operating indication of excessive accumulator pressure is retraction that exceeds normal speed. Initial accumulator pressure must be held at 400 psi. A safety diaphragm is installed on the air side of the accumulator to eliminate the possibility of an accumulator explosion.

Fluid Level Indicator Safety

When the engine is in BATTERY position, the fluid level indicator must read BATTERY. Should any other reading be indicated, the engine must not be operated until a battery indication is effected.

Malfunctions and Safety

Personnel must always be certain that their method of operation is not responsible for a malfunction. Possible malfunctions, causes, effects, and remedial action are listed in *Operational and Organizational/Intermediate Maintenance Manual with Illustrated Parts Breakdown, for all Shipboard Aircraft Recovery Equipment, NAVAIR 51-5BBA-2.1 and 2.2.*

SAFETY IN MAINTENANCE

Any engine not operable or shutdown because of malfunctions, breakdown, needed adjustment, or repair should have the deck pendant removed and all operating pressures relieved. Leaks indicate poor fittings or bad packing and result in pressure losses and probable malfunction. Every leak must be immediately investigated to determine the cause and the corrective action to be taken. Cleanliness concerning debris, waste wiping materials, and tools must be very strictly adhered to, particularly where involvement with operable parts may occur. A jammed up engine as a

result of carelessness with work materials could result in injury and/or loss of life. Lubrication tables for all equipment must be strictly adhered to. Venting the various lines to remove entrapped air, foam, or waste fluids is a preoperational and operational requirement. Safe operations depend upon strict adherence to these and all other pertinent safety instructions.

Molten Metal and Heating Methods

A detailed description of heating and using molten metal for pouring sockets is contained earlier in this chapter. Particular attention should be given to the warning notes and instructions regarding personnel safety. All personnel involved in terminal pouring operations or in any operations where molten metals are involved should wear goggles, gloves, aprons, and such other protective clothing as is necessary. Ample ventilation must be provided against fumes given off by molten metals.

Cables, Pendants, and Taut Lines

In running pendants, cables, or taut lines, personnel should be familiar with procedures so that equipment is placed without kinking, twisting, or unnatural positioning. Improper handling of cables will cause strand breakage and subsequent weakening and failure. Whenever deck tractors are used for pulling out pendants, all personnel must be on guard for cable lash.

Improper Landings

Personnel at deckedge stations or on deck duty must be alert during landing operations to stay clear of any aircraft and particularly those making offcenter or excessive-speed landings. Either type can lead to pendant failures, unequal stanchion loading in the event of barricade landings, and the possibility that such aircraft will go over the deck edge.

Safety Checklist

The following safety checklist should be posted at applicable locations:

- Replace broken, worn, or kinked deck pendants and barricade deck cables as soon as operations permit.
- Inspect deck pendants after each group of landings and after each excessive-load landing, such as extreme offcenter landings or extreme runoff to two-blocking.

- Lubricate deck pendants and barricade cables properly and frequently.
- Replace broken wire supports.
- Raise the barricade webbing to the proper height.
- Replace loose or damaged cable fittings and couplings.
- Do not allow terminal jamming of deck sheave housing.
- Remove debris and dirt from all areas.
- Remove the deck pendants from engines that are inactive.
- Keep stanchion area clear of personnel when raising and lowering cables and webbing assemblies.
- Do not reuse the barricade webbing system after an arrestment.
- Hookrunners should approach all arrested aircraft from the front to avoid jet blast and possible broken cable backlash.
- Keep flight deck clear of personnel until aircraft has come to a stop.
- Install barricade stanchion safety brace before making repairs.

REVIEW QUESTIONS

Q17. How should hook runners approach an aircraft?

Q18. What can cause walkback?

Q19. Before making repairs to the barricade stanchions, what must be installed?

Q20. What is the condition that can cause two-blocking?

Q21. What is an indication of excessive arresting engine accumulator pressure?

SUMMARY

You should now be able to describe the operation and function of the arresting gear engine systems; various operational and maintenance procedures; procedures to remove and replace crossdeck pendants; the barricade webbing to the stanchions; procedures used to dereeve and reeve arresting gear engine purchase cables and the procedures used to prepare, pour, and conduct proof-load tests on the wire rope terminals.

As important as the procedures are, you should now know to keep safety uppermost in mind. The safety precautions in force today have been bought many times over through reduction in damaged equipment, personnel injuries, and fatalities.

For complete recovery equipment operation, maintenance, overhaul, and safety instructions refer to *Operational and Organizational/Intermediate Maintenance Manual with Illustrated Parts Breakdown, for all Shipboard Aircraft Recovery Equipment, NAVAIR 51-5BBA-2.1 and 2.2.*

CHAPTER 4

STEAM-POWERED CATAPULTS

Steam is the principal source of energy and is supplied to the catapults by the ship's boilers. The steam is drawn from the ship's boilers to the catapult wet steam accumulator, where it is stored at the desired pressure. From the wet accumulator, it is directed to the launch valve, and provides the energy to launch aircraft. The most significant differences between the various types of steam catapults are the length and capacity. See table 4-1 for the differences.

Each steam catapult consists of eight major systems:

- Steam System
- Launching Engine System
- Lubrication System
- Bridle Tensioning System
- Hydraulic System
- Retraction Engine System
- Drive System
- Catapult Control System

STEAM SYSTEM

LEARNING OBJECTIVES: Describe the components of the steam system. Describe the function of the steam system.

The catapult steam system (fig. 4-1) consists of the steam wet accumulator, accumulator fill and blowdown valves, trough warm-up system, steam smothering system and the associated valves and piping. The steam system is under the technical cognizance of NAVSEASYSKOM and is operated and maintained by engineering department personnel. An explanation of

the steam system major components will provide a better understanding of catapult operations. Figure 4-2 is a simplified schematic of a typical catapult steam piping arrangement. The schematic only shows the piping and valves associated with a single catapult when lined up with the steam plant that normally supplies that catapult. Valves and piping that allow cross connecting of catapults with all steam plants are not shown. Cross connecting provides the capability of operating any catapult from any power plant.

WET ACCUMULATOR WARM-UP

The accumulator warm-up procedure allows valves and piping between the steam plant and the catapult to initially slowly warm up to bring the metal temperatures to operating level. Hot feed water is admitted into the steam accumulator to approximate the low operating level. The launch valve is opened to purge air from the accumulator and steam is slowly admitted into the accumulator feed water to raise the water temperature. When the water temperature reaches approximately 225 degrees, the launch valve is closed and accumulator heating continues. Steam pressure is increased in increments allowing enough time at each increment for the water temperature to increase to a predetermined temperature. This slow increase in temperature and pressure will ensure a thermally stable accumulator when operating parameters are reached.

TROUGH WARM -UP

The trough warm-up procedure allows valves and piping between the steam plant and the catapult to slowly warm -up to bring the metal temperatures to operating level. When steam is directed to a catapult for

Table 4-1.—Steam Catapult Data

Item	C-13-0	C-13-1	C-13-2
Power stroke (in feet)	249-10"	309-8 3/4"	306-9"
blTrack length (in feet)	264-10"	324-10"	324-10"
Weight of shuttle and pistons (in pounds)	6,350	6,350	6,350
Cylinder bore (in inches)	18	18	21
Power stroke displacement (in cubic feet)	910	1,148	1,527

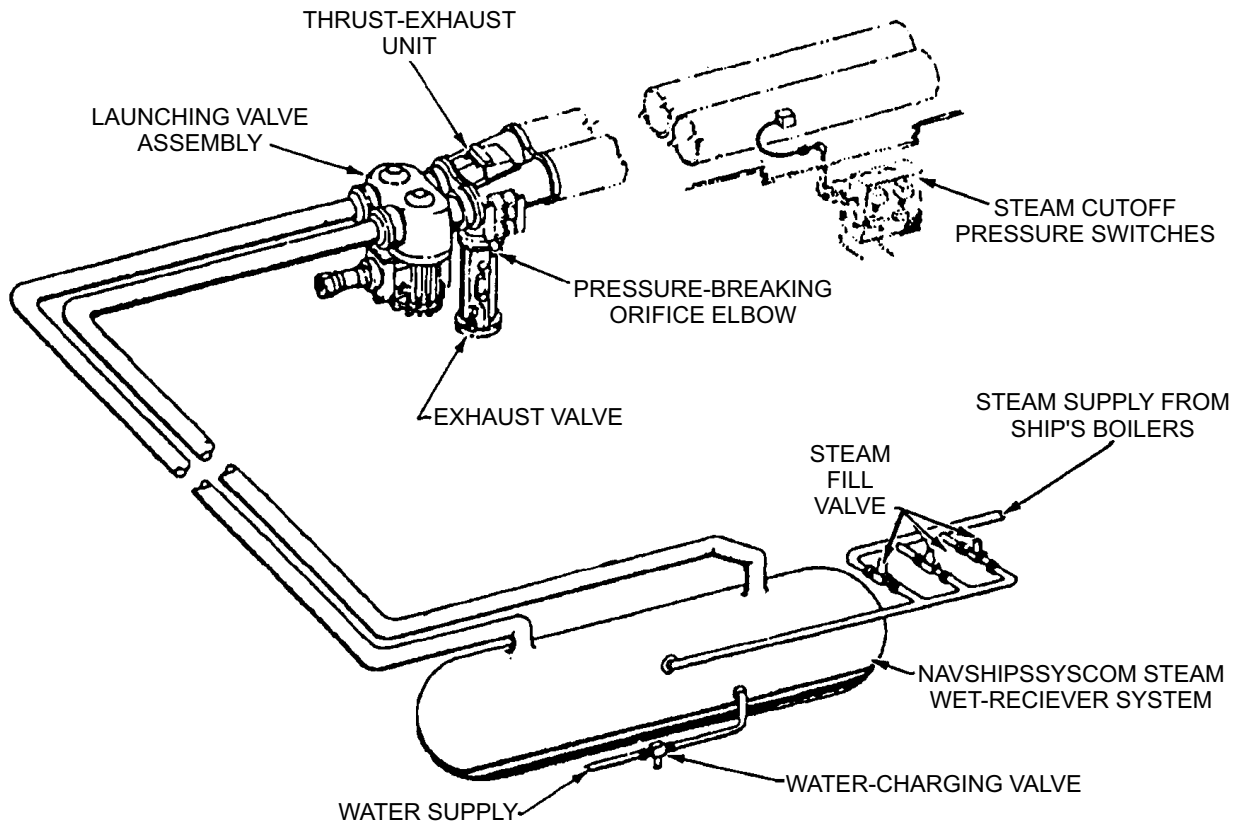

ABEf0402

Figure 4-1.—Steam system.

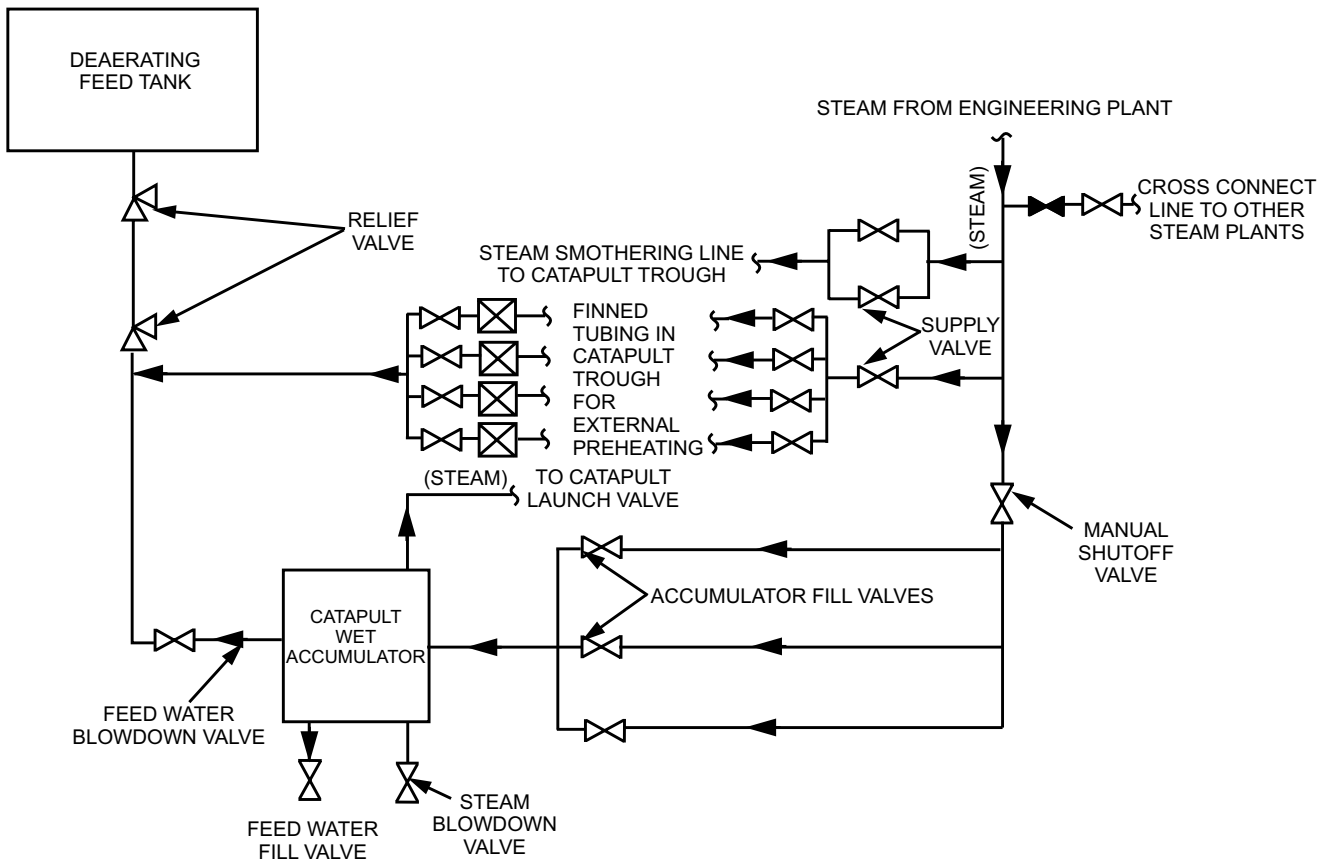

ABEf0403

Figure 4-2.—Steam system schematic.

accumulator warm-up, steam is available through a branch line and valves to the trough warm-up system (fig. 4-3). The launching engine cylinders are heated to operating temperature by a pair of trough heaters located below each row of launching engine cylinders. The trough heaters are installed in two sections referred to as the forward and aft legs. Each trough heater consists of a pipe within a larger pipe that is capped at the forward end. Steam is admitted into the inner pipe, then flows through the inner pipe into the outer pipe, heating the outer pipe. Fins installed on the outer pipe provide even radiation of heat to the launching engine cylinders, condensation from each outlet pipe is removed by drains lines which are equipped with fixed orifices. The orifices are sized so that water is removed at a rate that will maintain enough steam flow to heat and maintain the launching engine cylinders at operating temperature, bypass valves are provided around each orifice to remove excess water if required.

STEAM SMOTHERING SYSTEM

The steam smothering system (see fig. 4-3) provides a rapid means of extinguishing a fire in the catapult trough or in the launch valve compartment. The launch valve steam smothering is accomplished by admitting steam into a pair of lines encircling the launch valve area, holes in these lines direct steam to cover the area.

Trough steam smothering is accomplished by admitting main steam into a pipe located between the launching engine cylinders, holes in the pipe direct steam to all of the trough area. Trough steam smothering can be actuated pneumatically by a valve at deckedge or manually by a bypass valve located near the pneumatically operated steam supply valve.

WET ACCUMULATOR OPERATION

The steam accumulator provides a volume of steam under pressure to the launch valve assembly. At operating temperatures, when the launch valve opens and steam is released to the launch engine cylinders, steam pressure within the accumulator drops, when the pressure drop in the accumulator occurs, the steam fill valve opens and admits steam into the accumulator by means of a perforated manifold submerged in the water, this will rapidly heat the water back to the operating temperature. Water level will return its pre-established level.

LAUNCHING ENGINE SYSTEM

LEARNING OBJECTIVES: Describe the components of the launching engine system. Describe the function of the launching engine system.

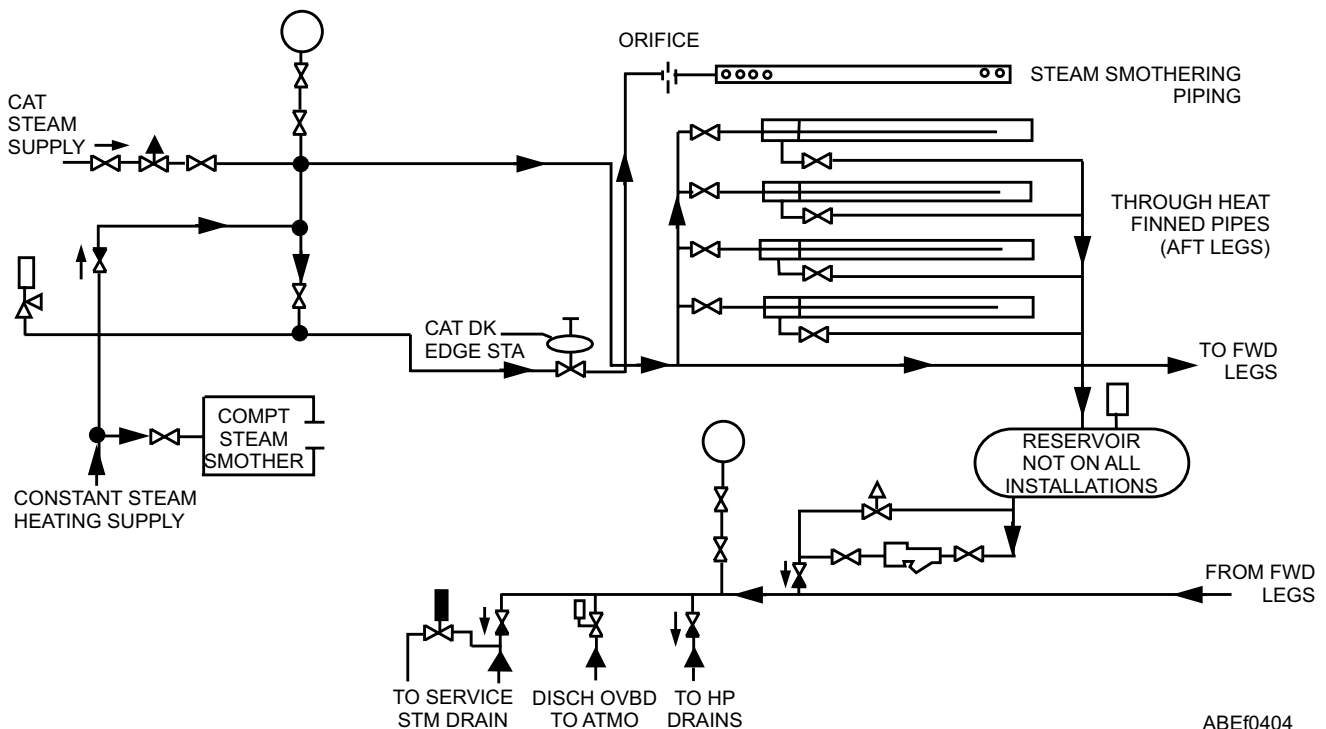

Figure 4-3.—Trough heat and steam smothering.

The launching engine system (fig. 4-4) consists of most of the major components that are used in applying steam to the launching engine pistons during launch operation and stopping the launch engine pistons at the completion of a launch. The major components that comprise the launching engine system are as follows:

- Launch Valve Assembly
- Thrust/Exhaust Unit
- Launch Valve Control Valve
- Exhaust Valve Assembly
- Pressure Breaking Orifice Elbow Assembly
- Keeper Valve
- Launch Valve Hydraulic Lock valve Panel Assembly
- Exhaust Valve Hydraulic Lock Valve
- Launching Engine Cylinders
- Cylinder Covers
- Sealing Strip
- Sealing Strip Tensioner Installation

- Sealing Strip Anchor and Guide
- Launching Engine Pistons
- Shuttle Assembly
- Water Break Installation
- Water break Piping and Pressure Switch Installation
- Steam Cutoff Switch Installation

LAUNCH VALVE ASSEMBLY

The launch valve assembly (fig. 4-5) is located between the two steam lines from the steam accumulator and the thrust/exhaust unit. Its consists mainly of a steam valve assembly, a hydraulic cylinder assembly, an operation control assembly, and the launch valve stroke timer electrical installation. A closed plate and an open plate are located on the operation controls frame and an increment plate is located on the operation controls crosshead. The position of the valve can be determined by the relationship of the increment plate to the closed and open plates.

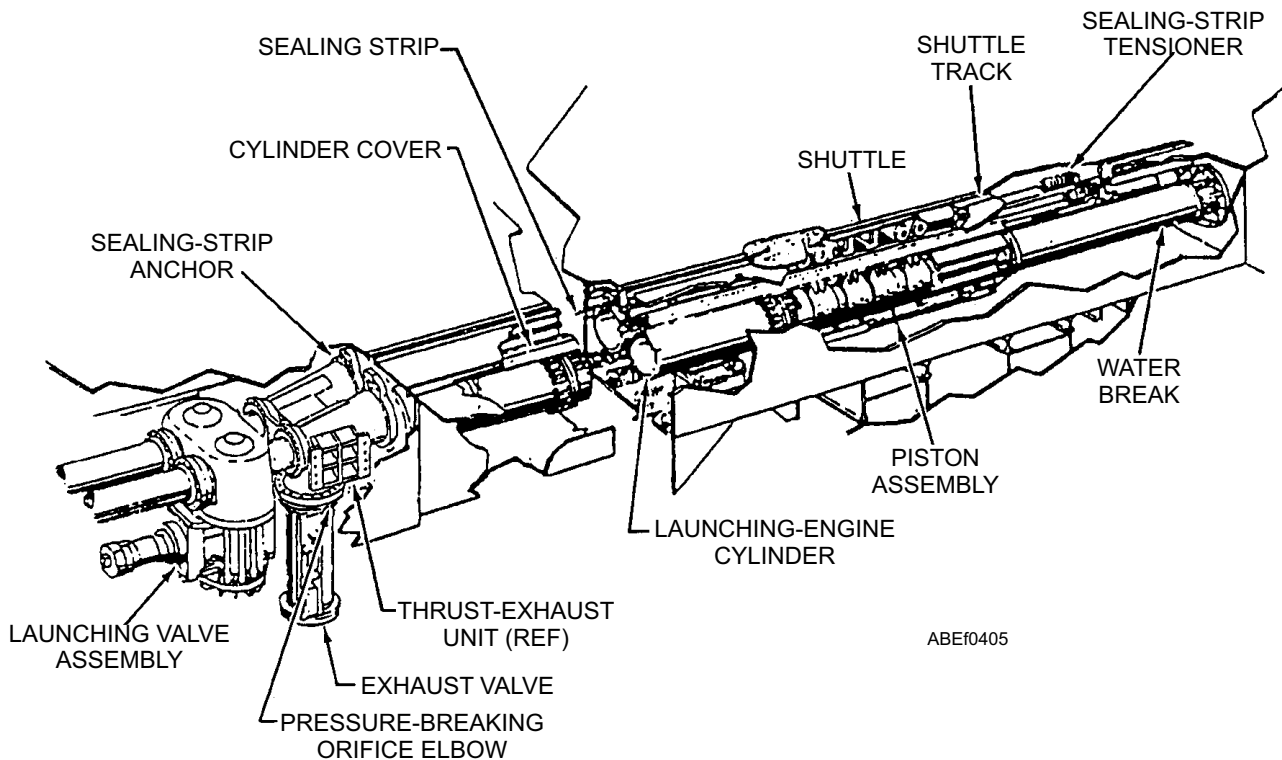

Figure 4-4.—Launching engine system (typical).

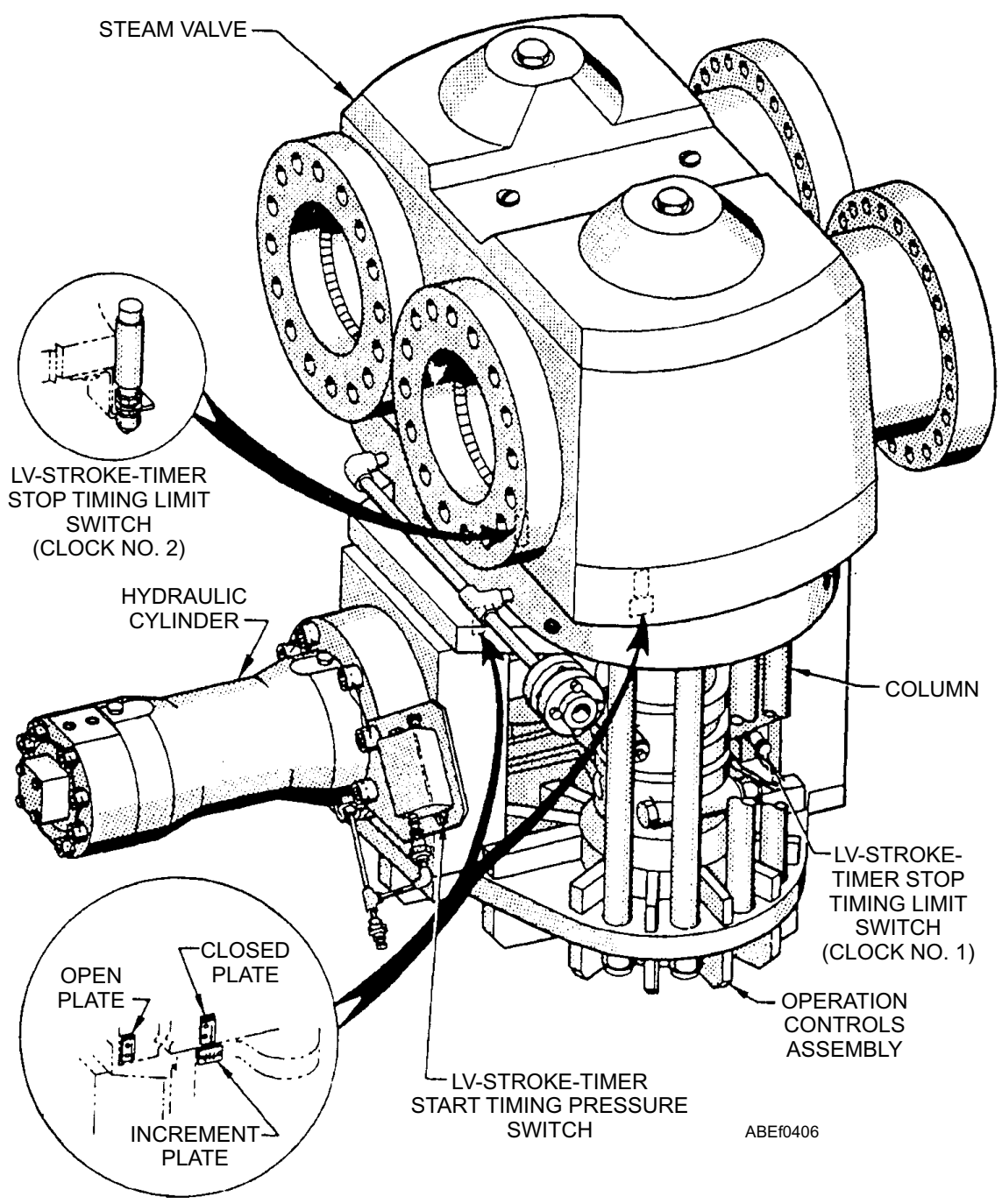

Figure 4-5.—Launch valve assembly (rotary).

STEAM VALVE

The steam valve (fig. 4-6) admits and shuts off the flow of steam to the launching engine cylinders during catapult operations. With the valve in the CLOSED position, two plugs in the valve are in full contact with the valve body seats, providing a tight seal. When the valve is opened, the plugs are moved away from the valve body seats and rotated 90 degrees. In the OPEN position, the circular openings in the plugs are in line with the valve body passages.

OPERATION CONTROLS ASSEMBLY

The operation controls assembly (fig. 4-7) is attached to the bottom of the steam valve assembly. The assembly provides vertical movement needed for seating and unseating the steam valve plugs and rotational movement needed for opening and closing the steam valve. Vertical movement of the plugs is obtained by the action of the lift nuts. Each lift nut has a steep angle thread that mates on each steam valve plug

shaft. Each lift nut is connected to the crosshead by a lifter lever and a lifter link. Movement of the crosshead, which is connected to the hydraulic cylinder piston rod, causes the lift nuts to rotate and the plugs to move toward or away from the steam valve body seats. Movement of the crosshead also obtains rotational movement of the plugs. Each plug shaft is connected to the crosshead by a rotator lever and a rotator link. With the steam valve in the CLOSED position, the plugs are fully seated. When the crosshead starts to move to the OPEN position, the lift nuts move the plugs downward, and the links and levers begin to rotate. Due to the geometrical arrangement of the levers, the plugs are moved away from the body seats before rotation begins. As the crosshead stroke approaches the FULL OPEN position, the plugs move toward the valve body seats. When the valve is fully opened, the plugs are not in contact with the body seats, because of the unequal lengths of the links, and the plugs and body parts are in perfect alignment. As the crosshead moves to the CLOSED position, the links and levers rotate the plugs upward to seat the plugs against the seats.

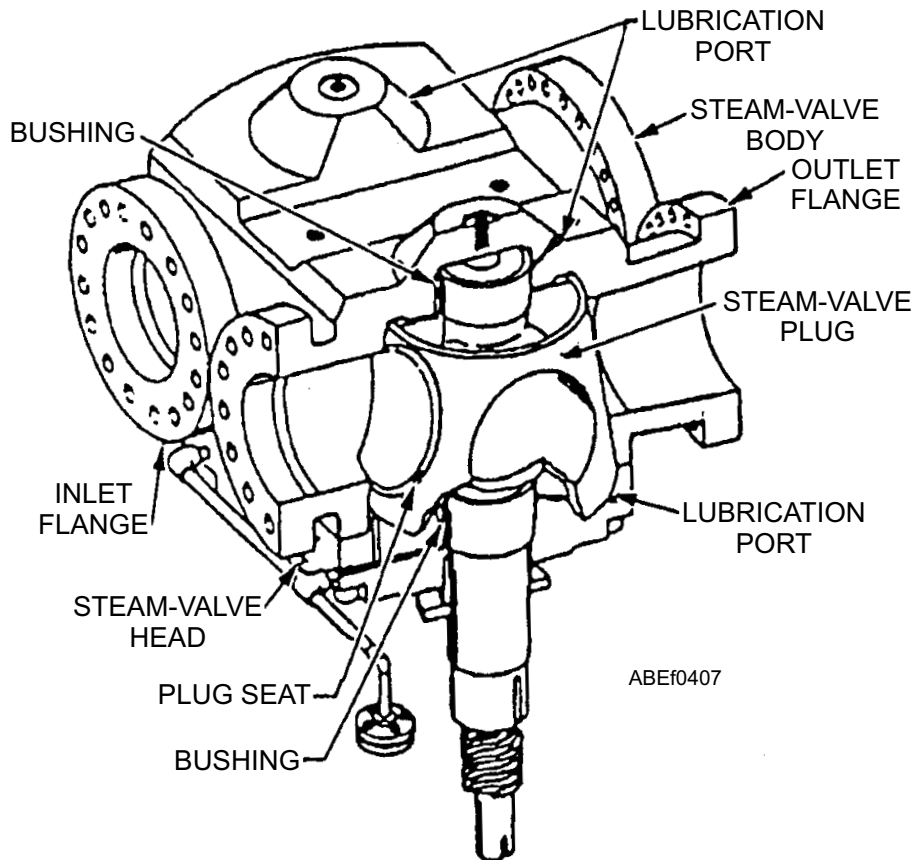
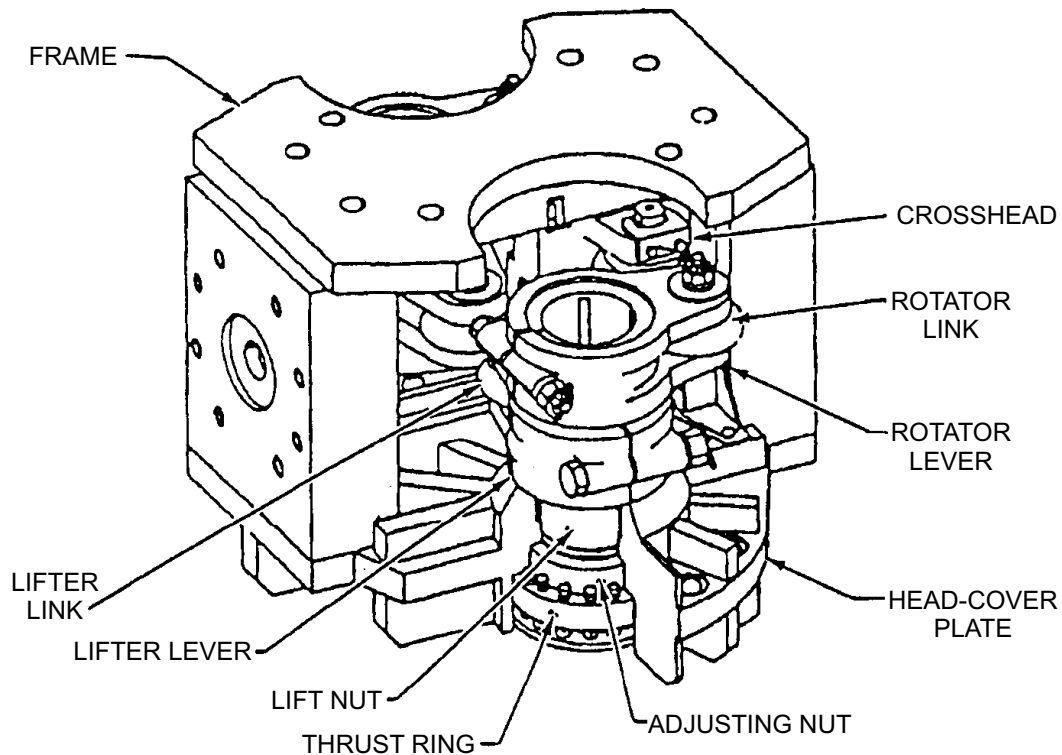

Figure 4-6.—Launching valve steam valve.



ABEf0408

Figure 4-7.—Launch valve operation control assembly.

HYDRAULIC CYLINDER ASSEMBLY

The hydraulic cylinder assembly (fig. 4-8) is connected to the operation control assembly. The hydraulic cylinder assembly is actuated by pressurized

hydraulic fluid to open and close the steam valve assembly. When pressurized fluid is applied to port E, the piston moves to the opposite end of the cylinder to open the steam valve. The rate of movement of the piston is faster at the beginning of the stroke, because of

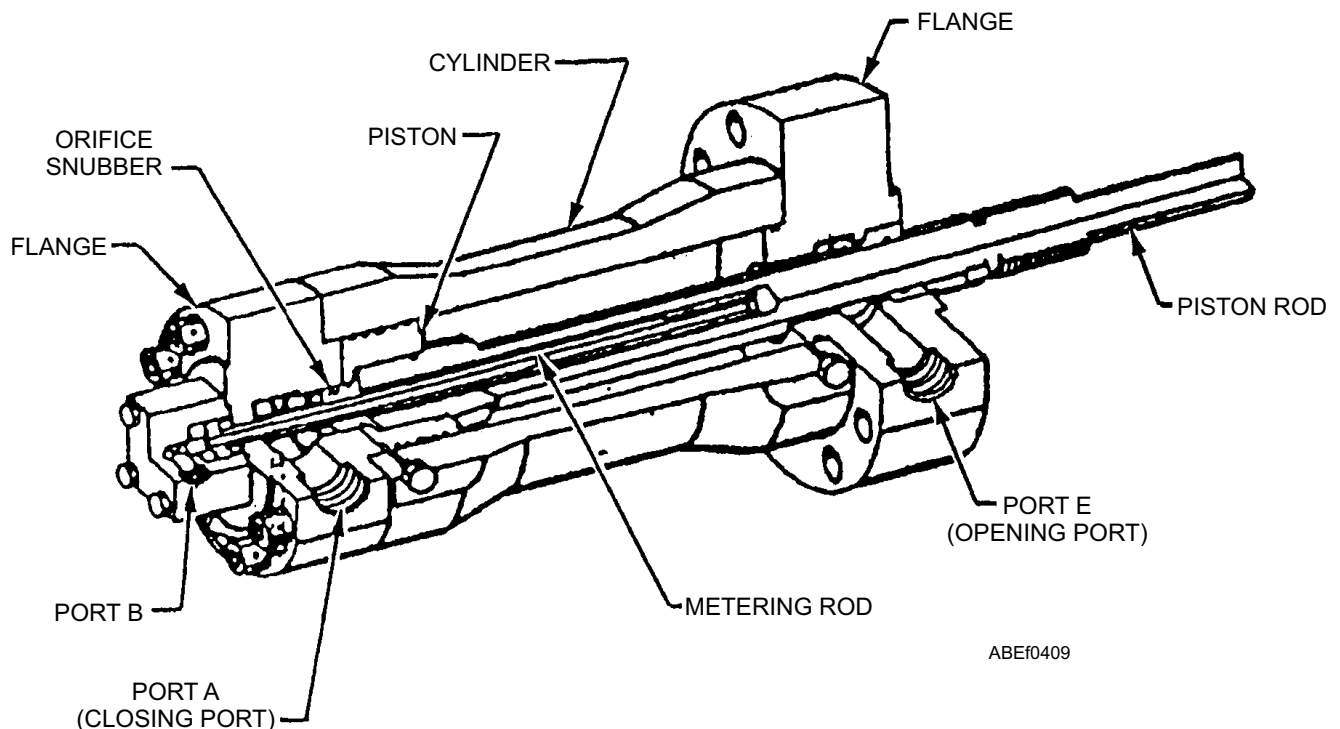

ABEf0409

Figure 4-8.—Launch valve hydraulic cylinder.

the effect of the metering rod. At the beginning of the opening stroke, fluid flows out of port A and port B. When the piston has moved approximately 1 inch into the cylinder, the metering rod shuts off the flow of fluid from within the cylinder to port B. At the end of the opening stroke, the orifice snubber controls the escape of fluid from the cylinder, this prevents the moving parts from slamming to a stop and possibly being damaged.

When pressurized fluid is applied to port A, the piston moves toward the opposite end of the cylinder to close the steam valve. At the end of the closing stroke, the tapered end of the piston rod enters the flange. This prevents the moving parts from slamming to a stop and possibly being damaged.

LAUNCH VALVE STROKE TIMER ELECTRICAL SYSTEM

The launch valve stroke timer electrical system (see fig. 4-5) provides a means of measuring the launch valve performance by timing the stroke from fully closed position to the point at which the crosshead has moved 9 inches. When the catapult is fired, fluid pressure from the hydraulic cylinder opening port E actuates the start timing pressure switch. This starts two

clocks which measure and displays time in seconds and hundredths of seconds. When the valve opens 3 1/2 inches, a limit switch on the crosshead opens and clock number one stops and display time elapsed. At the 9-inch stroke, a second switch opens, stopping and displaying elapsed time.

The timer clocks are located on the main control console for CV-64, CVN-65, and CV-67 and the central charging panel for CVN-68 through CVN 76. Variations in the launching valve stroke rates may seriously affect catapult performance. The launching valve stroke timers provide a means of detecting differences in the launching valve stroke. Deviations in the launching valve stroke can be detected by comparing current timer readings with previously established timer readings.

THRUST EXHAUST UNIT

The thrust/exhaust units (fig. 4-9) absorbs the thrust of the launch engine pistons and shuttle assembly, connects the launch valve to the power cylinders and to the exhaust valve, anchors the aft end of the launching, engine and prevents aft expansion of the launching engine cylinders.

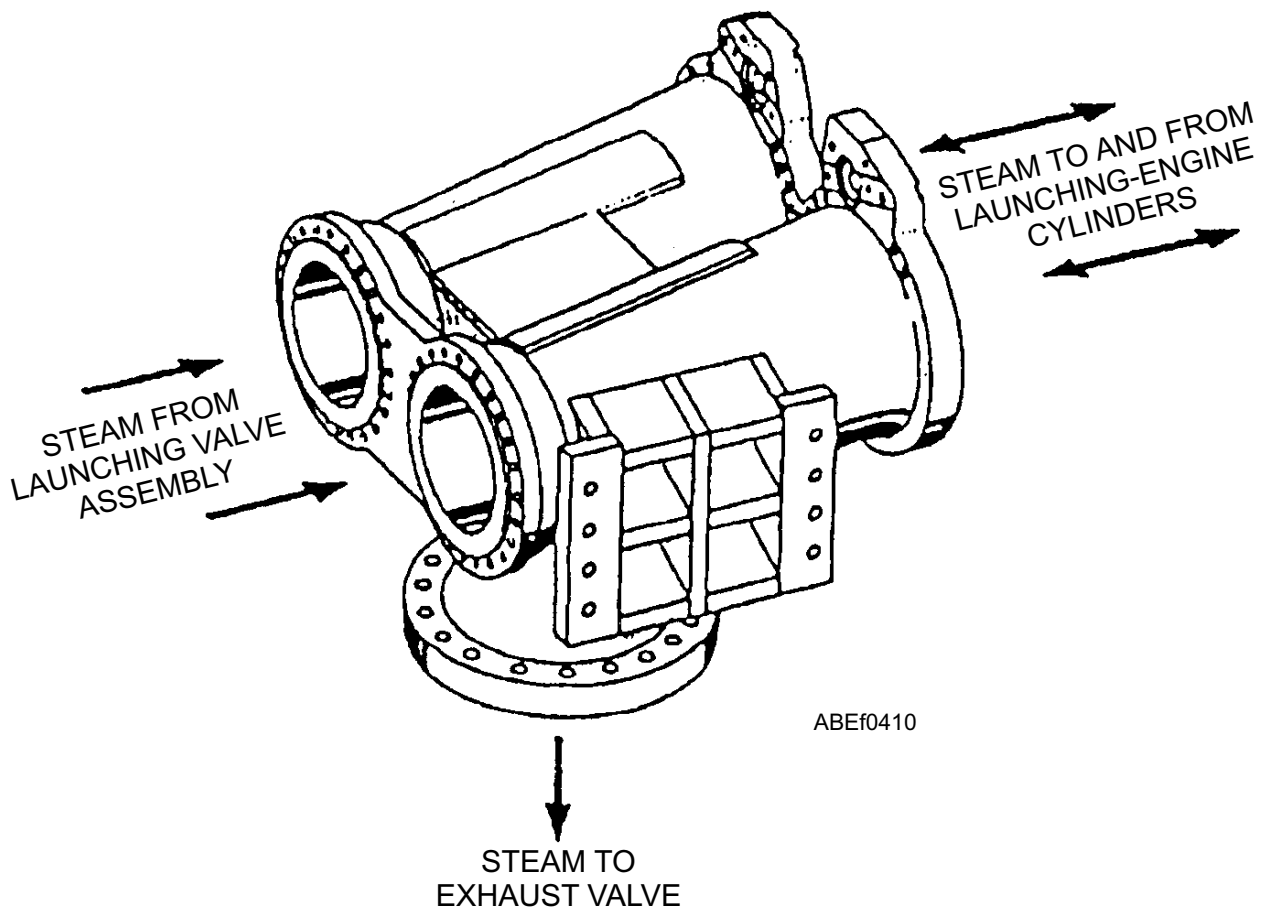

Figure 4-9.—Thrust exhaust unit.

In ships preceding CV-67, a thrust unit anchors the aft end of the launching engine and connects the steam accumulator to the launch valve. An exhaust tee mounted between the launch valve and the aft power cylinders also provides connection to the exhaust valve.

CAPACITY SELECTOR VALVE (CSV)

The CSV (fig. 4-10) provides the means of varying the energy output of the catapult by controlling the opening rate of the launch valve for aircraft of various types and weights. An electric motor unit assembly is used to position the CSV spindle, which meters the flow of fluid from the operating cylinder when the launch valve is opening, changing the valve setting for different capacity launchings. A handwheel is provided to change the valve setting should the automatic control become inoperative. For complete information concerning the CSV assembly, refer to technical manual NAVAIR 51-15ABE-1.

LAUNCH-VALVE CONTROL VALVE

The launching-valve control valve (fig. 4-11) directs pressurized hydraulic fluid to the launch valve hydraulic cylinder to open or close the launch valve. The control valve consists of a valve body enclosed on both ends by glands. A piston within the valve divides the control valve into seven chambers. Piping connects each chamber of the control valve to other components. As the launching valves go through their opening and closing cycles, fluid is being directed to the operating chambers by the action of the sliding piston, lining up the ports and allowing pressurized fluid to enter one chamber while venting the other chamber to gravity. A tailrod is attached to each end of the piston. The tailrods extend through the gland and provide a visual indication of the position of the control valve. Pressurized fluid used to shift the control valve is supplied through the launch valve solenoid-operated hydraulic lock valve.

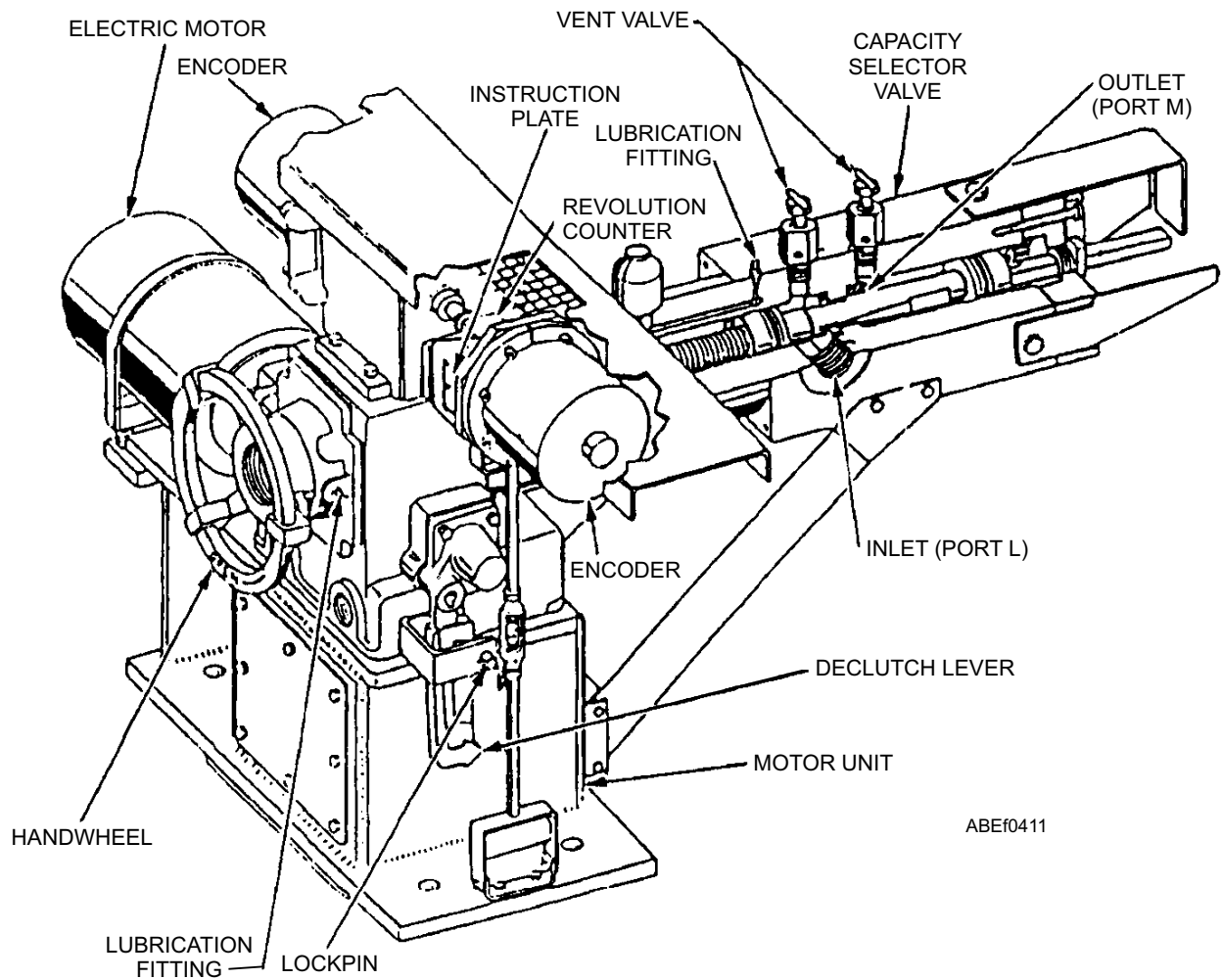

Figure 4-10.—Capacity selector valve assembly.

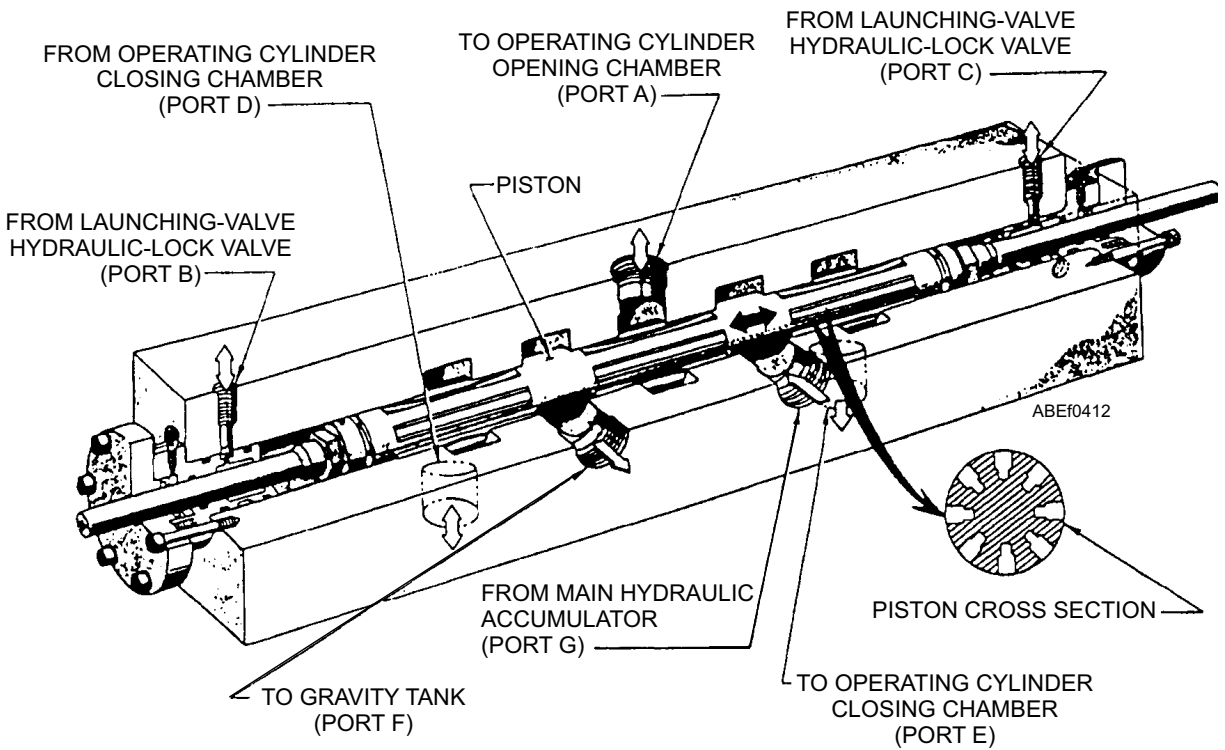

Figure 4-11.—Launch-valve control valve.

BUTTERFLY EXHAUST VALVE

The butterfly exhaust valve (fig. 4-12) provide the means to direct spent steam from the launching engine cylinders overboard after the launch valve closes at the completion of a launch. The exhaust valve is attached to the bottom flange of the thrust/exhaust unit or exhaust tee; it consists primarily of a valve body, a disc, and a hydraulic actuator. Prior to launch, hydraulic pressure is directed from the exhaust valve hydraulic lock valve to the closing port of the hydraulic actuator causing the piston to move downward and the disk within the valve body to move onto its seat. A switch is then actuated that energizes a portion of the electrical circuitry that allows the launch sequence to continue. After a launch, when the launch valve closes, hydraulic pressure is directed from the exhaust valve hydraulic lock valve to the opening port of the hydraulic actuator causing the piston to move upward and the disk within the valve body to move off its seat and release the spent steam overboard. The limit switch is released and allows for a portion of the electrical circuitry necessary to allow retraction of the launching engine pistons.

PRESSURE-BREAKING ORIFICE ELBOW

The pressure-breaking orifice elbow (fig. 4-13) prevents a buildup of steam pressure behind the

launching engine pistons when the launch valve is closed. The pressure breaking orifice elbow is attached to a flange on the thrust/exhaust unit or exhaust tee above the exhaust valve assembly and contains an orifice that is large enough to allow the escape of launch valve steam leakage but small enough to have no detrimental effect on catapult performance. Any steam, which may leak through the closed launch valve when the exhaust valve is closed, is permitted to escape through the pressure-breaking orifice. This prevents a build-up of pressure that could cause premature release of an aircraft from its holdback bar restraint.

KEEPER VALVE

The keeper valve (fig. 4-14) prevents the exhaust valve from opening while the launch valve is open. The keeper valve is located in the piping between the launch and exhaust valve lock valves and the closing chamber of the exhaust valve actuator. The valve consists of a block with an internal cylinder containing a movable piston. The keeper valve is actuated by hydraulic fluid from the launch-valve hydraulic lock valve. When the launch valve opens, the piston of the keeper valve shifts and blocks the flow of hydraulic fluid to the exhaust valve hydraulic actuator. This prevents the exhaust valve from opening until the launch valve is closed and the keeper valve piston is shifted.

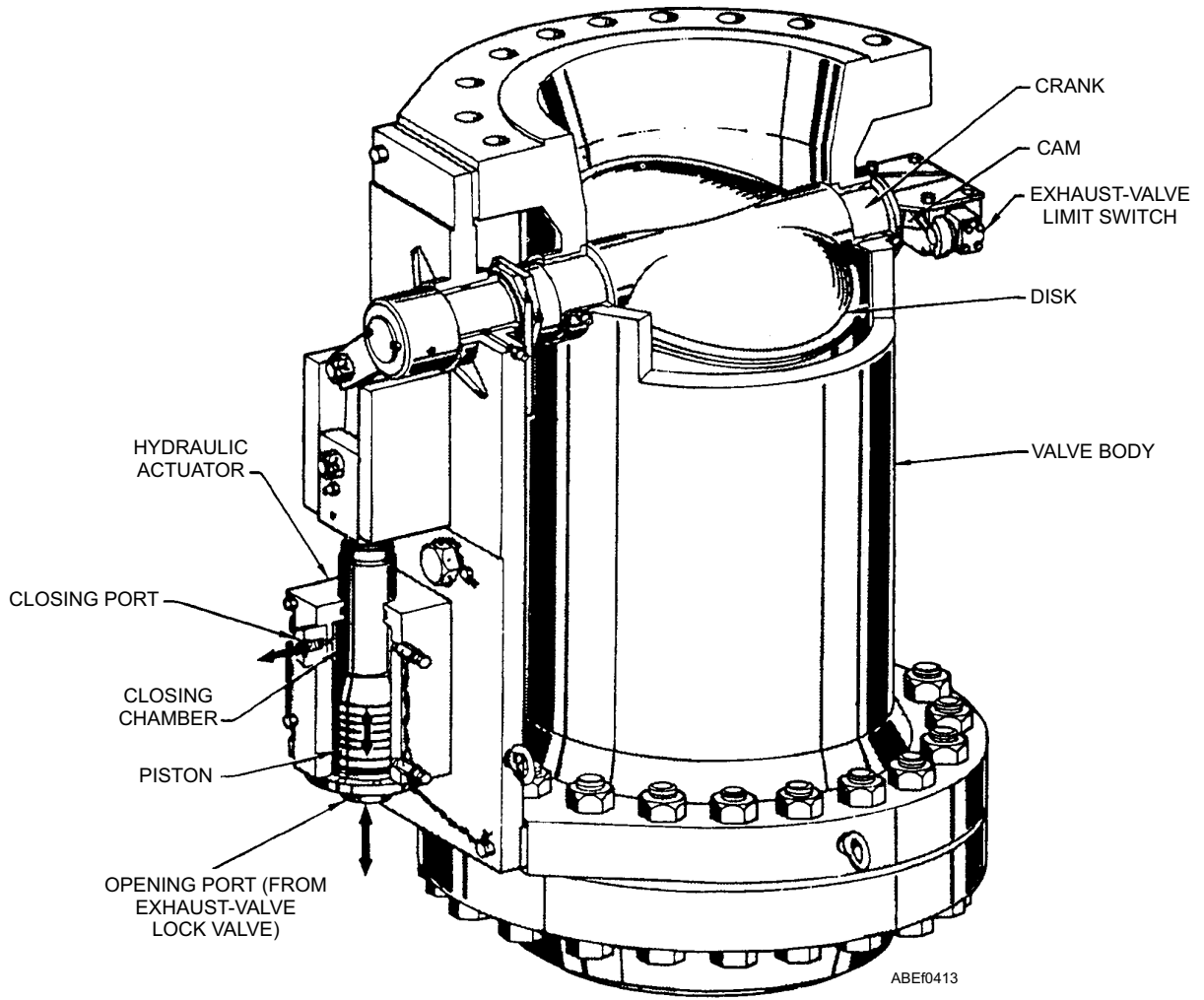
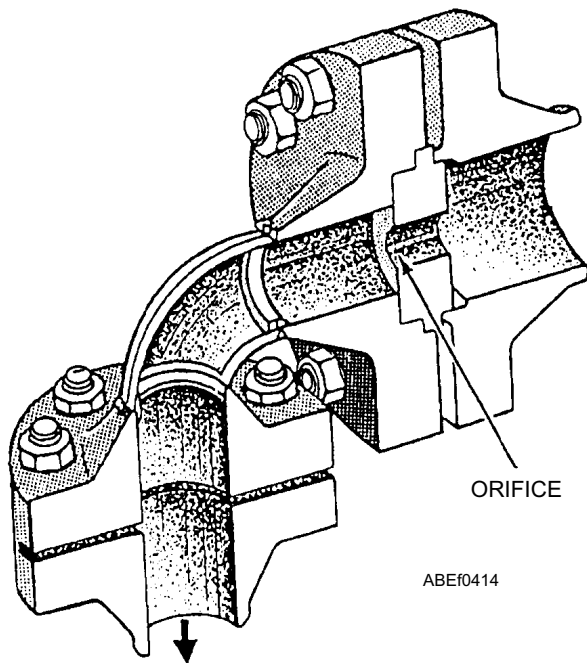

Figure 4-12.—Butterfly exhaust valve.



TO OVERBOARD EXHAUST LINE
Figure 4-13.—Pressure-breaking orifice elbow.

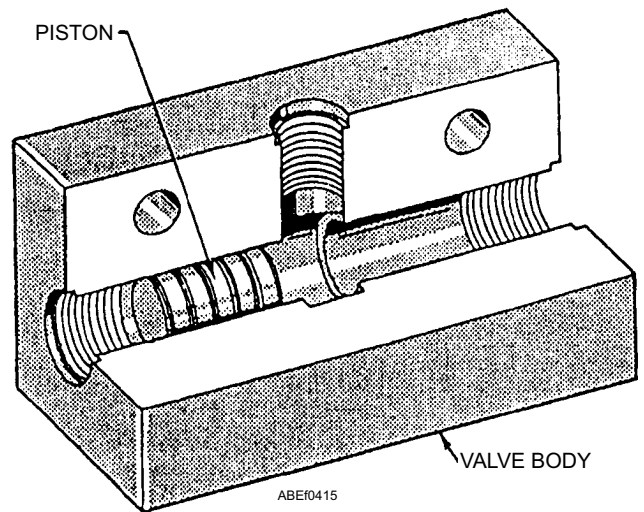

Figure 4-14.—Keeper valve.

HYDRAULIC-LOCK-VALVE PANELS

There are two hydraulic-lock-valve panels, one for the launch valve (fig. 4-15) and one for the exhaust valve (fig. 4-16). The launch-valve hydraulic-lock-valve panel consists of two air-solenoid valves, a hydraulic lock valve with lock positioner, the launch pilot latch solenoid, and piping connections. The launch-valve hydraulic lock valve (fig. 4-17) provides a hydraulic lock to hold the launch-valve control valve in the FIRED position until launch is completed or until the launch-valve emergency cutout valve is placed in the EMERGENCY position, by controlling the flow of fluid to the launch-valve control valve.

The launch pilot latch solenoid controls a plunger that prevents the lock valve from being shifted to the FIRED position unless the catapult control system is in the FINAL READY phase of operation. (A manual lock screw [fig. 4-17] is provided to secure the valve during nonoperational periods.) When the catapult FIRE

circuit is energized, the fire air-solenoid valve directs air pressure to shift the lock valve to the fired position. This causes pressurized fluid to be directed from port A through port B to the launching-valve control valve, the keeper valve, and port D via the launch-valve emergency cutout valve. Fluid pressure in port D hydraulically locks the valve in the fired position. When the catapult LAUNCH COMPLETE circuit is energized, the close launch valve air-solenoid directs air pressure to again shift the lock valve, venting port D to gravity and directing pressurized fluid from port A through port C to the launch-valve control valve and closing the launch valves. (During a HANGFIRE condition, port D is vented and port C is pressurized when the launch-valve emergency cutout valve is placed in its EMERGENCY position, ensuring that the launch valves remain closed.)

The exhaust-valve hydraulic-lock-valve panel (see fig. 4-16) consists of the exhaust-valve hydraulic lock valve, two air-solenoid valves, and piping connections.

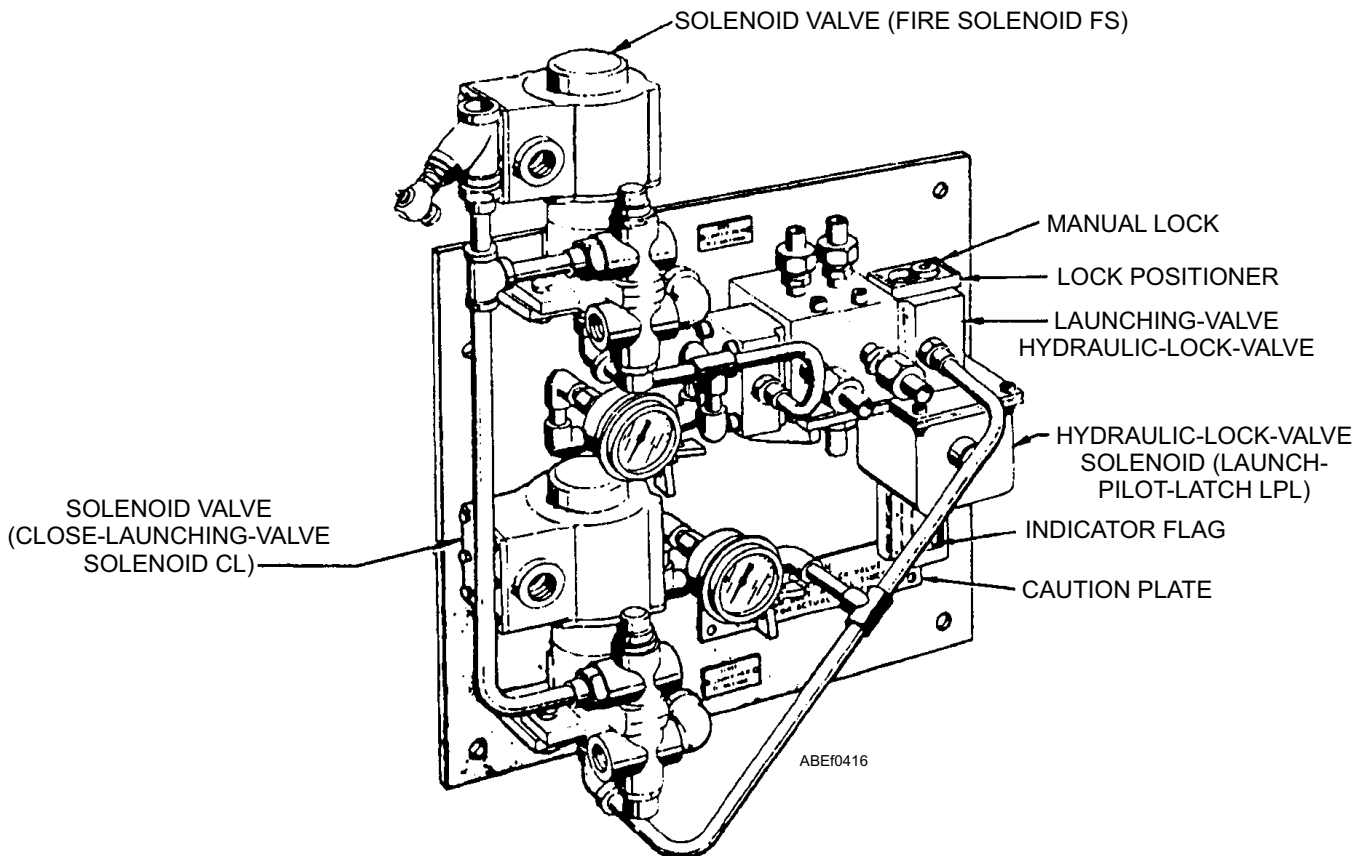

Figure 4-15.—Launch-valve hydraulic-lock-valve panel.

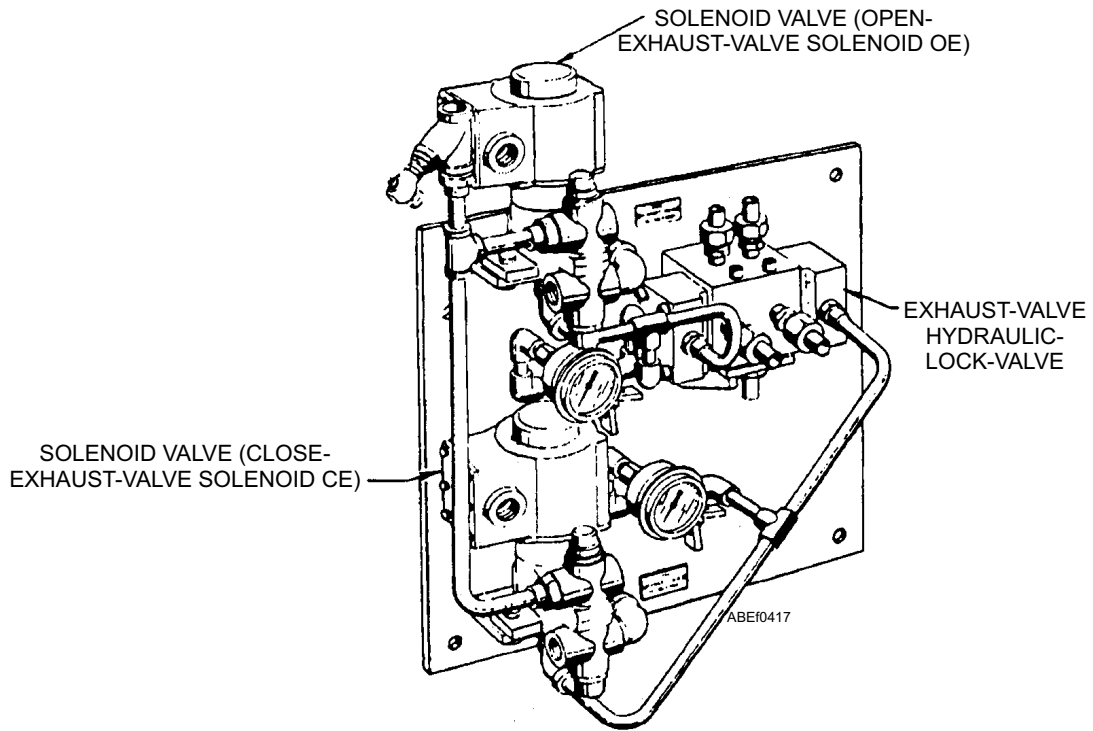

Figure 4-16.—Exhaust-valve hydraulic-lock-valve panel.

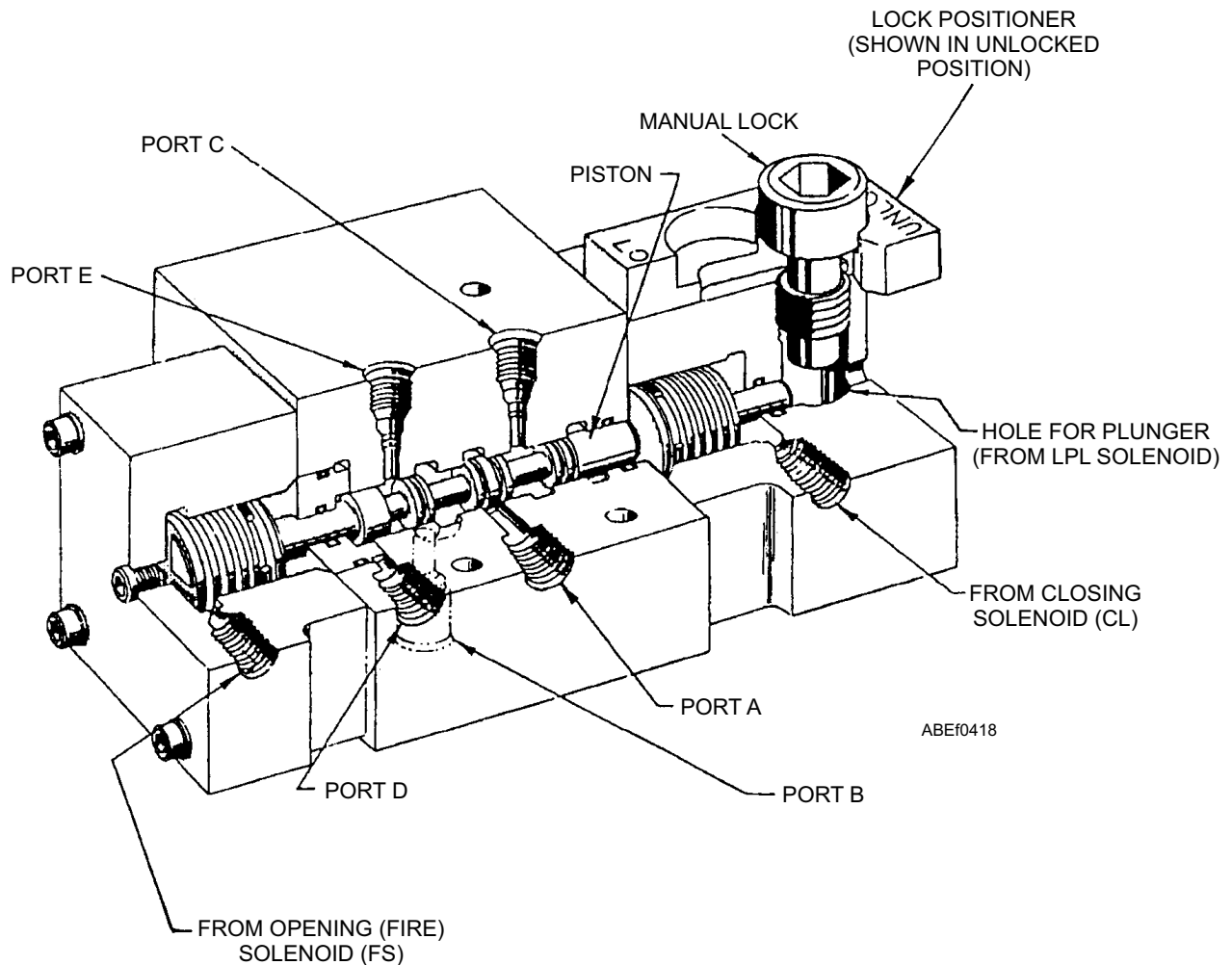

Figure 4-17.—Launch-valve hydraulic lock valve.

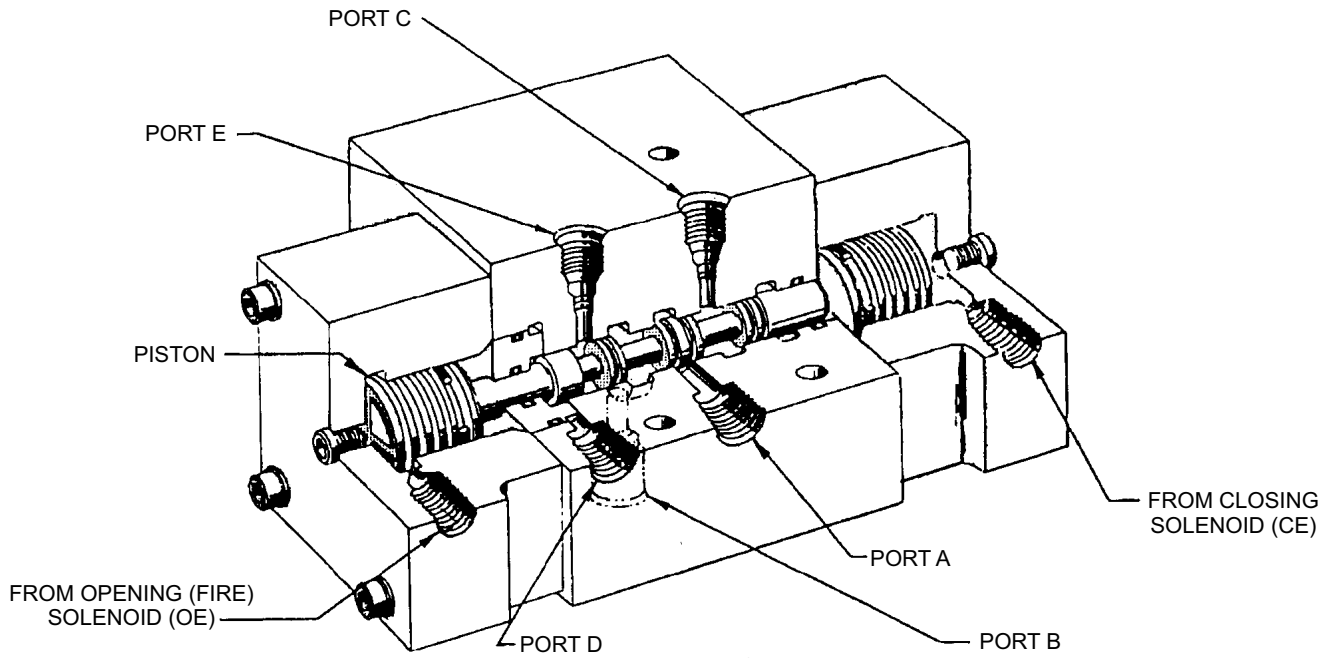
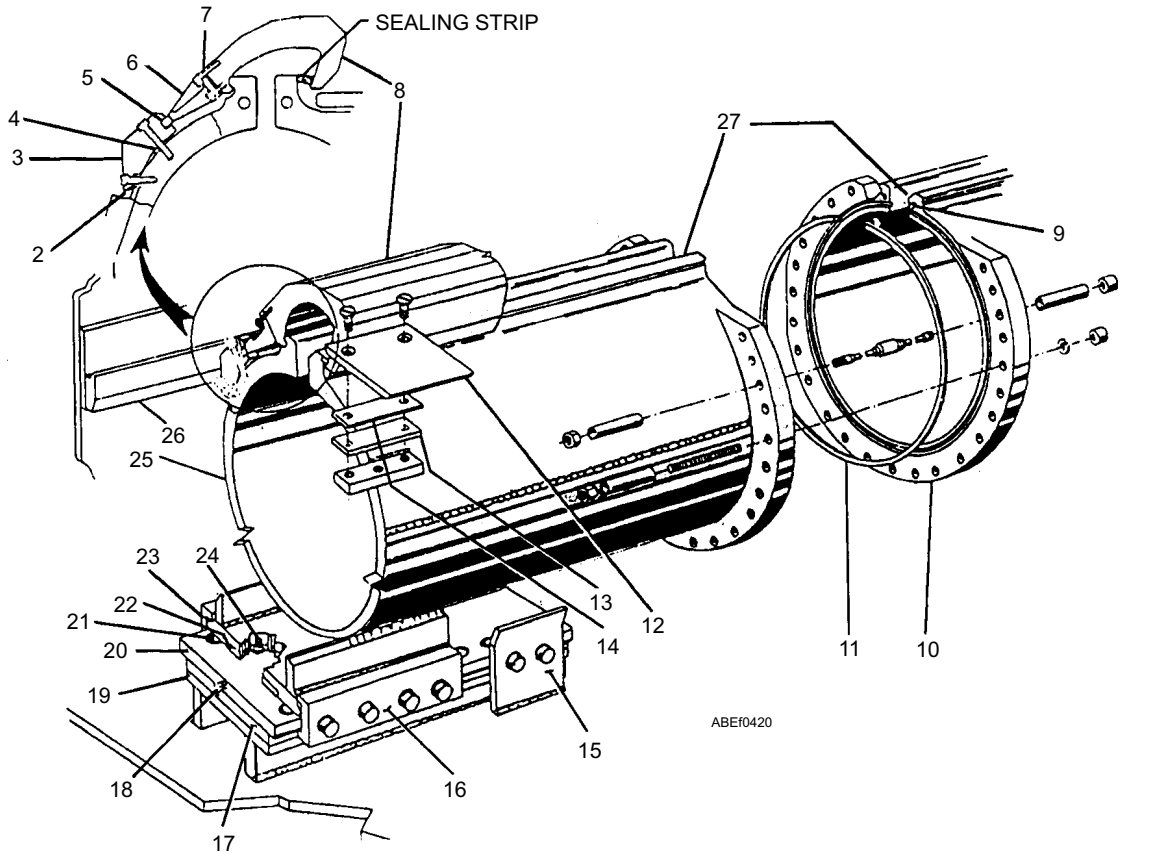

Figure 4-18.—Exhaust-valve hydraulic lock valve.



- | | | |
|--------------------------------|--------------------------|-------------------------------|
| 1. Thick spacer | 10. Flange | 19. Pad (NAVSHIP) |
| 2. Shim | 11. Aligning ring | 20. Baseplate |
| 3. Cylinder outer block | 12. Cable support plate | 21. Bolt |
| 4. Thin spacer | 13. Cable support spacer | 22. Bearing pad |
| 5. Cylinder outer-block spacer | 14. Cable support shim | 23. Cylinder base |
| 6. Cover support bracket | 15. Guide | 24. Screw |
| 7. Shim | 16. Clamp | 25. Launching engine cylinder |
| 8. Cylinder cover | 17. Shim (NAVSHIP) | 26. Track supporting bar |
| 9. Dowel pin | 18. Lubrication fitting | 27. Cylinder slot |

Figure 4-19.—Typical Cylinder Section.

The exhaust-valve hydraulic lock valve (fig. 4-18) opens and closes the exhaust valve by controlling the flow of hydraulic fluid to the exhaust-valve actuator. When the exhaust-valve open solenoid is energized, air pressure is directed to the opening side of the lock valve, causing it to shift. This allows fluid to flow from port A, out port B, through the keeper valve, and into the opening chamber of the actuator. Fluid also flows from port D to lock the valve in the OPEN position. When the exhaust-valve closed solenoid is energized, air pressure shifts the lock valve to the closed position, allowing fluid to flow from port A, out port C, and into the closing chamber of the exhaust-valve actuator. The valve is locked in this position by pressure from port A acting on the larger working area of the lock valve piston.

LAUNCHING ENGINE CYLINDERS

Each catapult has two rows of launching engine cylinders (see fig. 4-4) mounted parallel to each other in the catapult trough. Each row of cylinders is made up of sections that are slotted on the top and flanged at each end, with the number of sections determined by the overall length of the catapult. The cylinder sections are bolted together at their flanges (fig. 4-19) by means of long stud bolts, spacers, and nuts. The spacers and long

stud bolts are designed to minimize bolt failure due to uneven thermal stress within the cylinders during pre-heating and operation. Each cylinder is identified by a serial number stamped on the outer surface of its flange.

Base pads are welded in the bottom of the catapult trough at specified intervals to match the bearing pads fastened to the cylinder bases. Shims are then used to properly align each cylinder section, and then the cylinder sections are secured to the trough base pads by bolts and clamps, which prevent the lateral movement of the cylinders while allowing smooth elongation of the cylinders due to thermal expansion. Lubricator fittings are provided for lubrication of the sliding surfaces.

CYLINDER COVERS

The cylinder cover (fig. 4-20) acts as clamps holding the slotted portion of the cylinder in position to prevent radial spreading when steam pressure is applied. Space is provided in the cylinder covers for the sealing strip. Lubrication oil is supplied to the launching engine cylinders through lubrication ports and lubricators in each cover. Cylinder cover support brackets, screwed to the cylinder, hold the cylinder cover in place. Cover seals are used to seal and maintain alignment of each cylinder cover section.

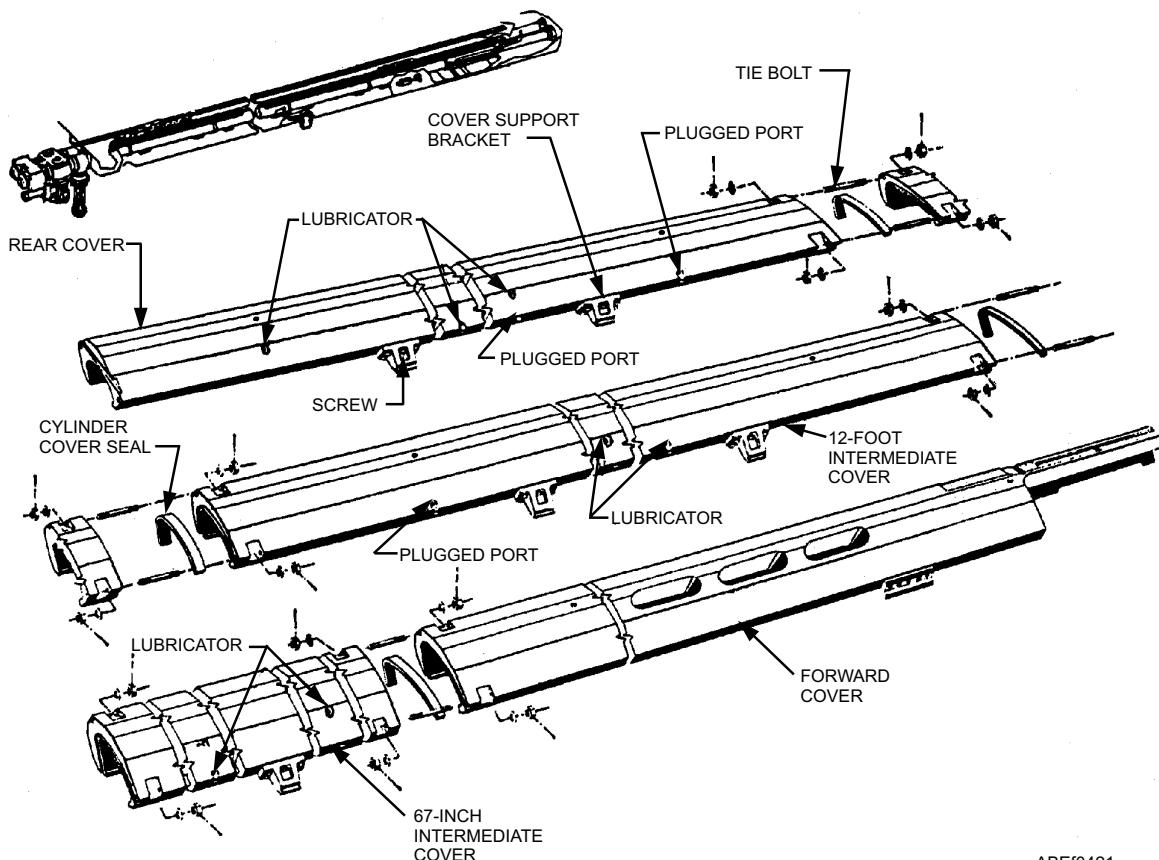

ABEF0421

Figure 4-20.—Launching engine cylinder covers.

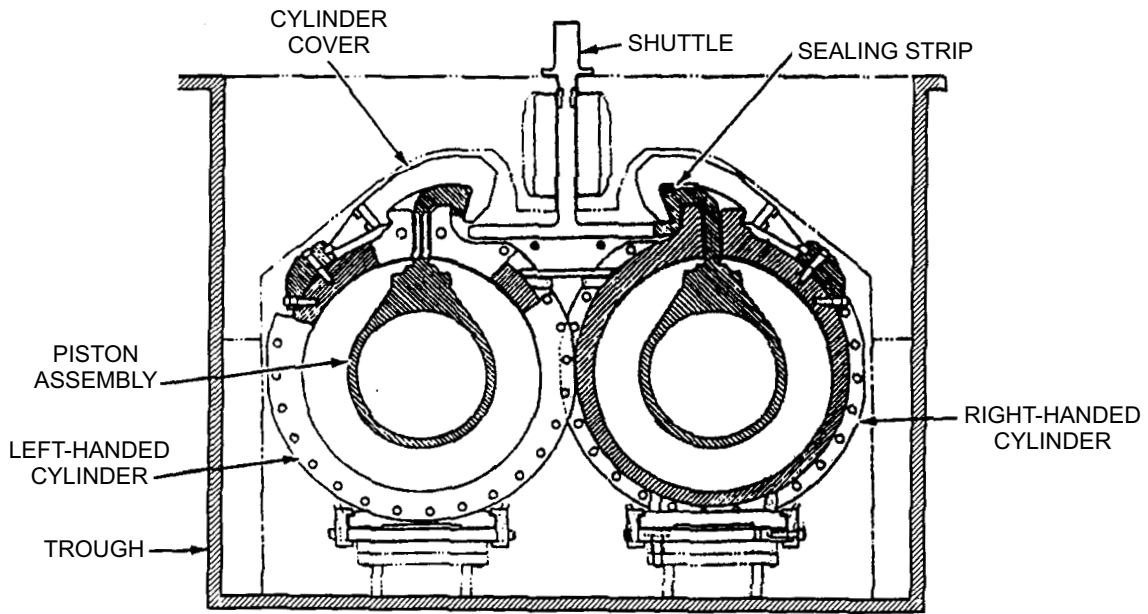

ABEF0422

Figure 4-21.—Cross section of launching engine cylinders (typical).

CYLINDER SEALING STRIPS

The sealing strip (fig. 4-21) prevents the loss of steam from the cylinders by sealing the space between the cylinder lip and the cylinder cover. As the steam piston assemblies move through the cylinders, the

piston connectors lift the sealing strips and the sealing strip guides reseal them. Action of the sealing strip is shown in figure 4-22. View A shows the strip position forward of the piston assembly. View B shows the connector lifting the strip to permit the piston-shuttle connector to pass under it. View C shows the guide

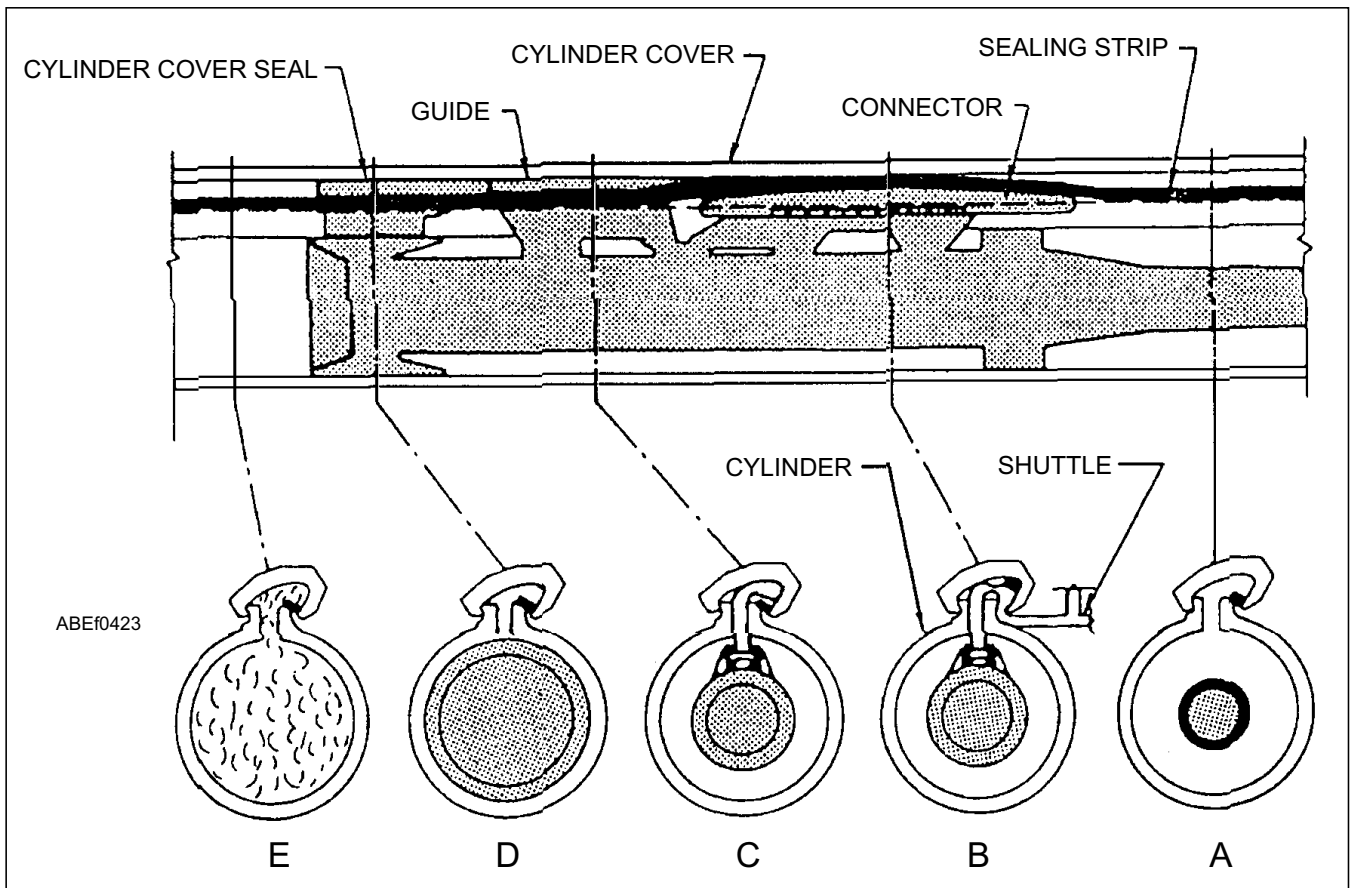

Figure 4-22.—Sealing strip action.

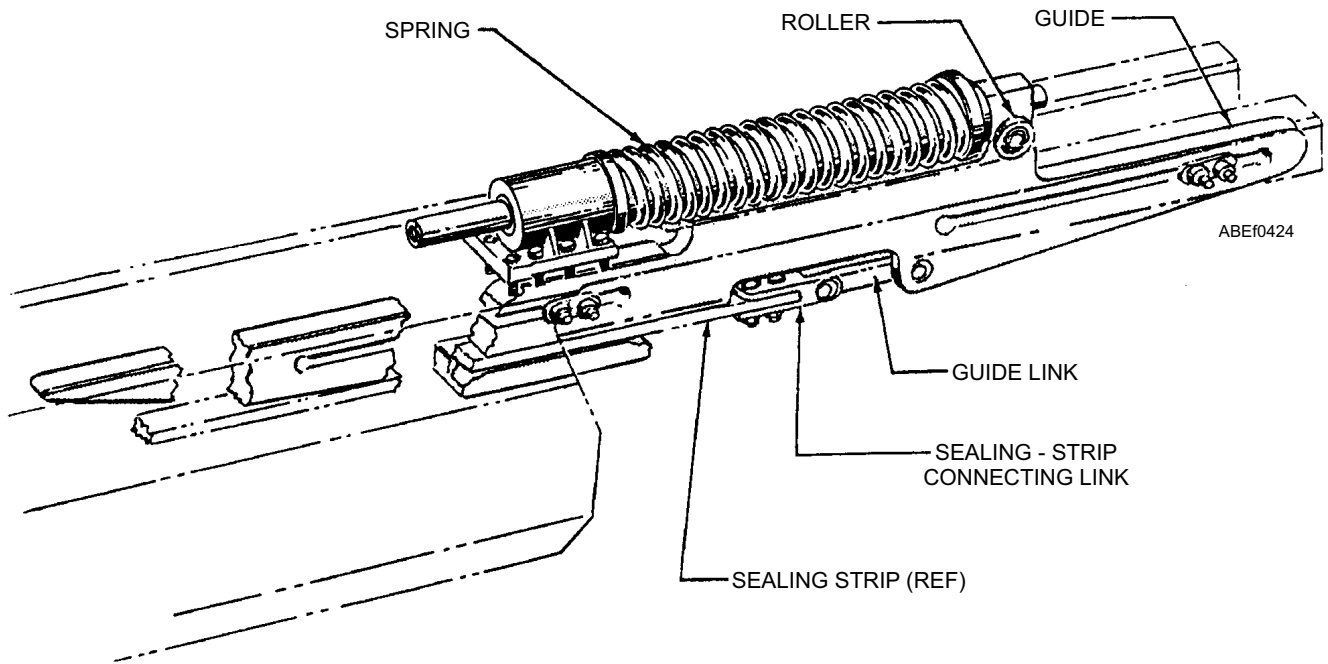

Figure 4-23.—Sealing strip tensioner.

re-laying the strip into its sealing position. View D shows the final step in seating. View E shows the strip fully seated with steam pressure keeping it seated.

SEALING STRIP TENSIONER

The sealing strip tensioner (fig. 4-23) is mounted on the end of the most forward cylinder cover on each cylinder. It applies constant tension to the sealing strip and holds the forward end of the strip in place. The tensioning force applied to the sealing strip is provided

by a compressed spring. This force is transmitted to the sealing strip through the tensioner guide, which is free to slide back and forth on rollers.

SEALING STRIP ANCHOR AND GUIDE INSTALLATION

The sealing strip anchor and guide installation (see fig. 4-24) is mounted on the forward flange of each thrust/exhaust unit or exhaust tee. It anchors the after end of the sealing strip by gripping the strip between a

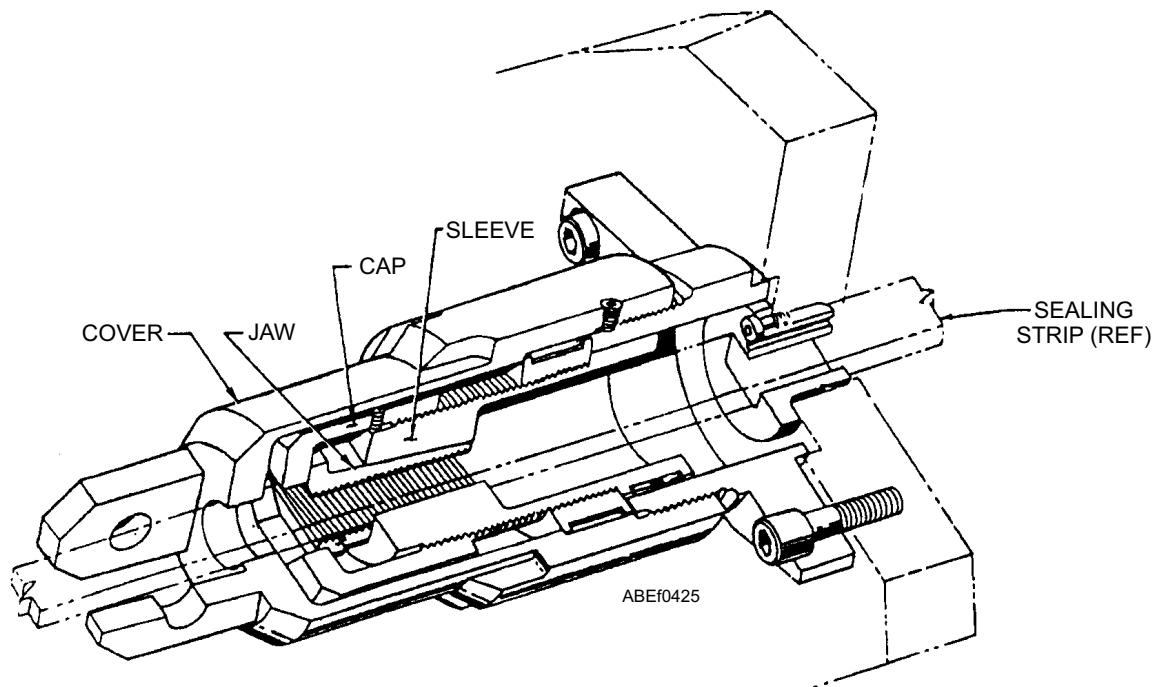

Figure 4-24.—Sealing strip anchor and guide.

set of jaws wedged into a hollow sleeve and held in place by a threaded cap

STEAM PISTON ASSEMBLY

The launching engine piston assembly (see fig. 4-25) consists of left and right hand launching pistons and attaching parts. The launching engine pistons are installed side by side in the launching engine cylinders the shuttle assembly provides the connection for one launching piston to the other along with the connection to the aircraft. The pressurized steam in the launching engine cylinders drives the launching engine steam piston assemblies. They, in turn, drive the shuttle. Component parts of each piston assembly are the steam piston, the barrel, the connector, the strip guide, the piston guide, and the tapered spear

The barrel serves as the chassis for the other components of the assembly. The piston is bolted to the aft end of the barrel; the piston rings installed on the piston seal the space between the piston and the cylinder wall. The cylinder cover segmented seal assembly acts as an extension of the piston into and through the cylinder slot. This seal assembly consists of a housing, three upper seal segments, and six lower seal segments. The upper seal segments press against the cylinder covers, and the lower seal segments press against the sides of the cylinder slot to prevent the loss of steam pressure from behind the steam pistons as the piston assemblies move through the cylinders during

the power stroke. The connector and the strip guide are bolted to the top of the barrel. The connector lifts the sealing strip off its seat to permit passage of the shuttle assembly along the cylinder. The strip guide returns the sealing strip to its seat after the connector passes under it, minimizing loss of steam pressure as the piston assembly advances through the power stroke. In addition, the connector has interlocking "dogs," which couple with matching "dogs" on the shuttle assembly to effect the connection between the connectors and the shuttle assembly.

The tapered spear and bronze piston guide are bolted to the forward end of the barrel. The piston guide acts as a bearing surface for the piston assembly and keeps it centered with respect to the cylinder walls. The tapered spear works in conjunction with the water-brake cylinder assemblies to stop the piston assemblies and shuttle at the end of the power stroke.

SHUTTLE ASSEMBLY

The shuttle assembly (see fig. 4-26) carries the forward motion of the pistons to the aircraft by means of a launch bar attached to the aircraft nose gear and connected to the nose gear launch shuttle spreader. The meshing of interlocking "dogs" of the piston assembly connectors and the shuttle frame connect the shuttle and the piston assemblies.

The shuttle is essentially a frame mounted on rollers. Two pairs of rollers fitted with roller bearings

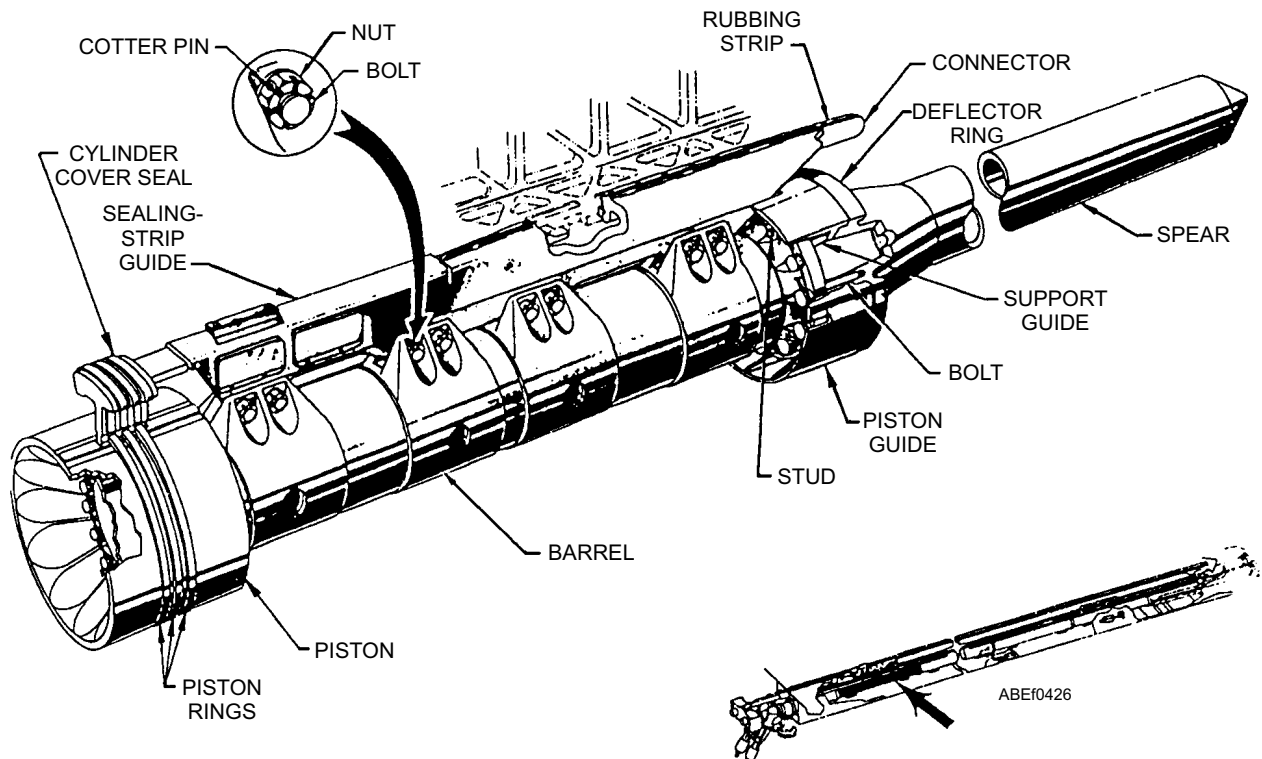

Figure 4-25.—Launching engine steam piston assembly.

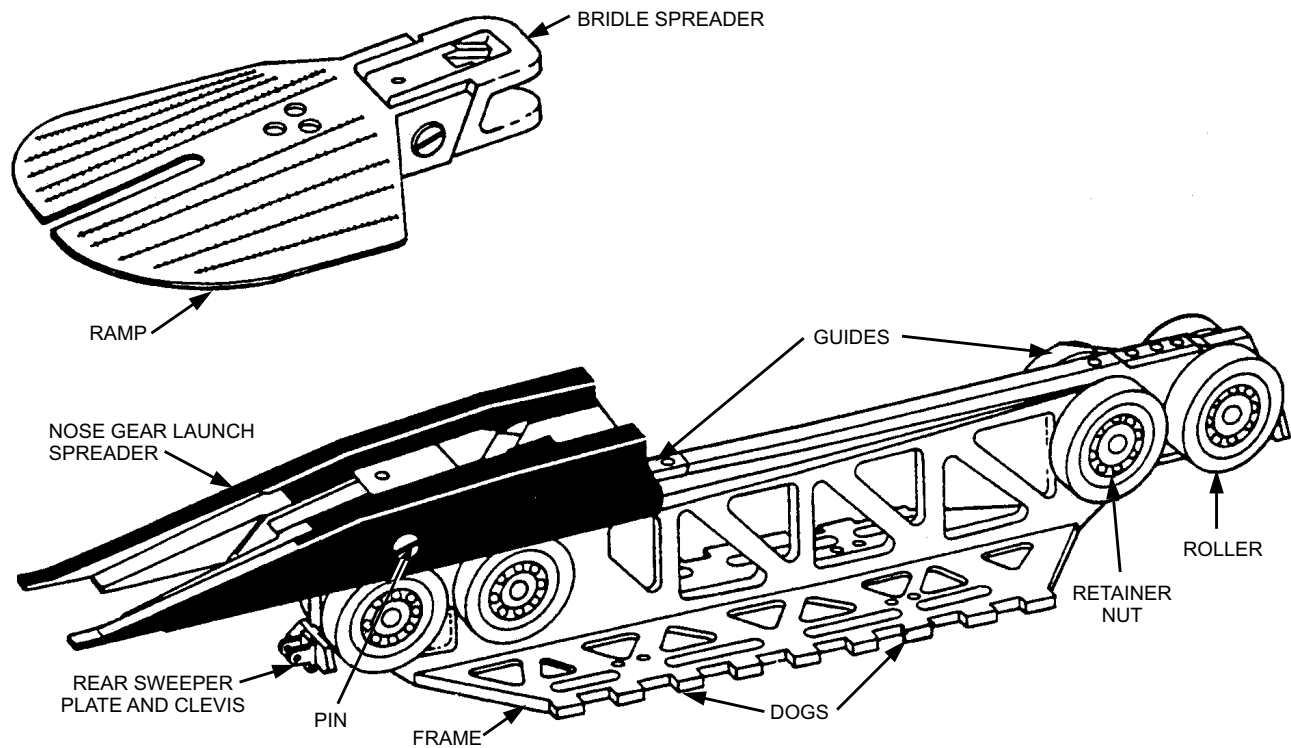

Figure 4-26.—Shuttle assembly.

ABEf0427

are installed on hubs mounted at each end of the shuttle frame. The shuttle is installed in a track between and above the launching engine cylinders. The trough covers form the shuttle track, which supports and guides the shuttle.

The bearings of the rollers are lubricated through fittings, which are accessible through the slot in the shuttle track. The shuttle blade is part of the shuttle

frame and is the only part that protrudes above the shuttle track. The nose gear launch spreader is attached to the shuttle blade.

WATER-BRAKE CYLINDERS

The water-brake cylinders (fig. 4-27) are installed at the forward end of the launching engine cylinders.

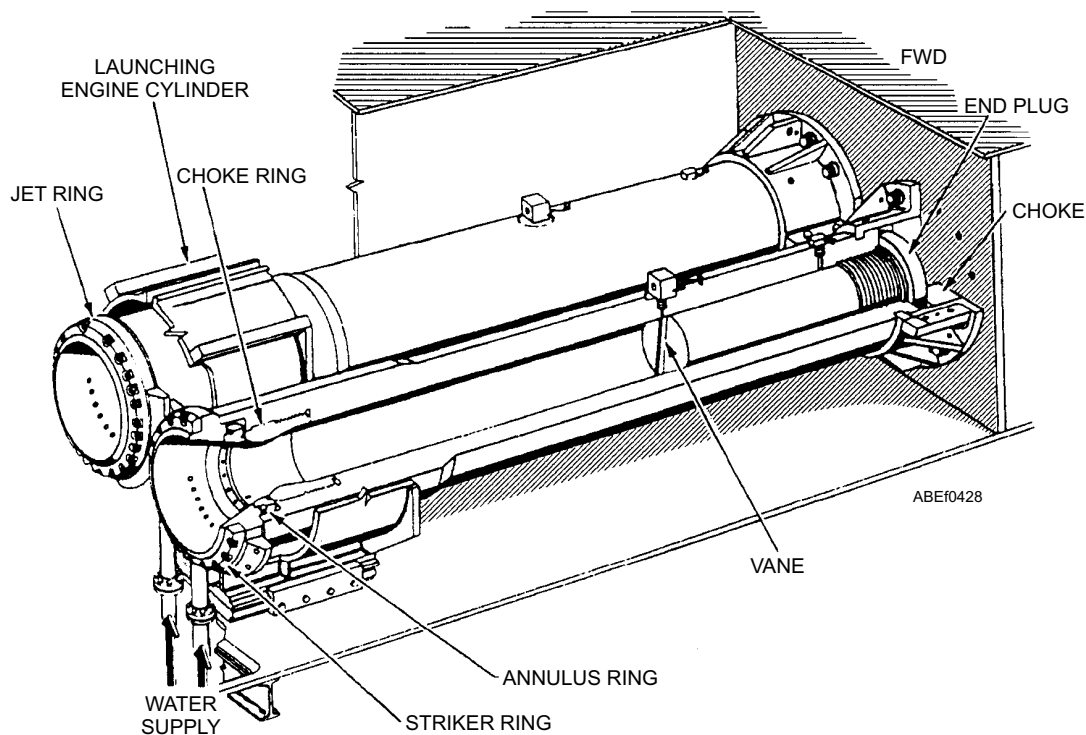

Figure 4-27.—Water-brake cylinder installation.

ABEf0428

The water brakes stop the forward motion of the shuttle and pistons at the end of the catapult power stroke. The after end of each water-brake cylinder is supported and aligned by the most forward section of each launching engine cylinder, which telescopes over the after end of the water-brake cylinder. The forward end of each cylinder is anchored in place by an upper bracket and lower support saddle and chock.

The open end of each cylinder holds four rings. They are the choke ring, the annulus ring, the jet ring, and the striker ring.

The choke ring is the innermost ring and is threaded into the water-brake cylinder. The annulus ring has angled holes machined in it to direct pressurized water into the cylinder and forms a vortex (whirlpool) at the open end of the cylinder. The jet ring is bolted to the end of the cylinder and holds the annulus ring in place. The striker ring, the outermost of the four rings, are designed to absorb the impact of any metal-to-contact between the launching engine piston assemblies and the aft end of the water brakes.

WARNING

To prevent damage to the water brakes and piston assembly components, a water-brake pump must be running any time the shuttle and piston assemblies are not fully bottomed in the water brakes.

A vane is keyed to the end plug (see fig. 4-27). Its purpose is to break up the vortex caused by the annulus ring and to create a solid head of water in the cylinder,

which is maintained by the continued vortex action at the mouth of the cylinder.

Braking action occurs at the end of the power run when the tapered spear on the piston assembly enters the water brake. Water in the brake is displaced by the spear and forced out the after end of the cylinder between the choke ring and the spear (fig. 4-28). Since the spear is tapered, the space between the choke ring and the spear is gradually decreased as the spear moves into the brake cylinder. This arrangement provides a controlled deceleration and energy absorption, which stops the piston assembly within a distance of about 5 feet without damage to the ship's structure.

WATER-BRAKE TANK

The water-brake tank is installed below the water-brake cylinders to supply water to and reclaim water spillage from the water brakes during operation. It has a minimum capacity of 3,000 gallons of fresh water. Overflow and oil-skimming funnels and bottom drains are provided in the tank to maintain proper water level and to remove excess oil used in the lubrication of the launching engine cylinders.

WATER-BRAKE PUMPS

Water is supplied to the water-brake cylinders by two electric-motor-driven, rotary-vane-type pumps installed in the immediate vicinity of the water-brake tank. They are capable of producing 650 gallons of water per minute at 80 psi. The pumps are electrically interlocked so that if the running pump breaks down,

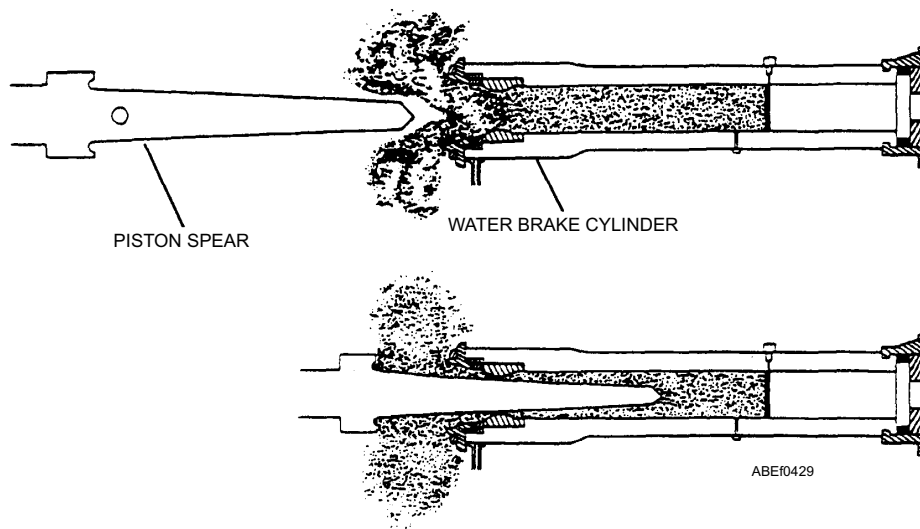

Figure 4-28.—Water brakes.

the alternate pump automatically starts running. A gauge board within the pump room contains gauges for pump suction and discharge pressure and for measuring the water pressure at the connectors (elbow pressure).

WATER-BRAKE WATER SUPPLY PIPING

The suction inlets of the pumps (fig. 4-29) are submerged in the water-brake tanks. The pump discharges each with appropriate valves and a flow-limiting orifice plate, are tied together and connected via flexible hoses to strainer flanges at the bottom of the water supply pipes. Hoses and rigid piping connect the pressure switches to the supply pipes. A pump suction gauge and a pump discharge gauge are located on the gauge panel for each pump. These are in addition to the gauges for the pressure sensing switches. The suction side of the pump consists of an inlet with a gate type shutoff valve, a gauge valve, and a Macomb strainer immediately ahead of the pump inlet. A petcock for venting is mounted at the top of the strainer. The discharge side of each pump includes a flow limiting orifice plate, a check valve, and a gate type shutoff valve. Two discharge lines merge into a

single line, which later splits into two lines. High-pressure, flexible hoses lead to and connect to the brake cylinder water supply connectors, which are attached to the water-brake cylinders. A drain valve for the water-brake tank leads to an overboard discharge. Fresh water from the ship's system is added to the tank via fill and shutoff valves in the water-brake pump room.

WATER-BRAKE PRESSURE-SENSING SWITCHES

Two pressure switches are connected to the piping leading from the pumps to the brake cylinders (see fig. 4-29). They usually are installed on the bulkhead adjacent to the tank. The switches are electrically tied in with the main control console/ICCS/CCP to prevent operation in case the pressure falls below normal. Water pressure keeps the switch contacts closed, thus completing a circuit. Should the pressure fall below normal, either one or both of the switches will drop open, breaking the circuit. There are also two pressure gauges in the lines to give a visual indication of the pressure, commonly referred to as "elbow pressure."

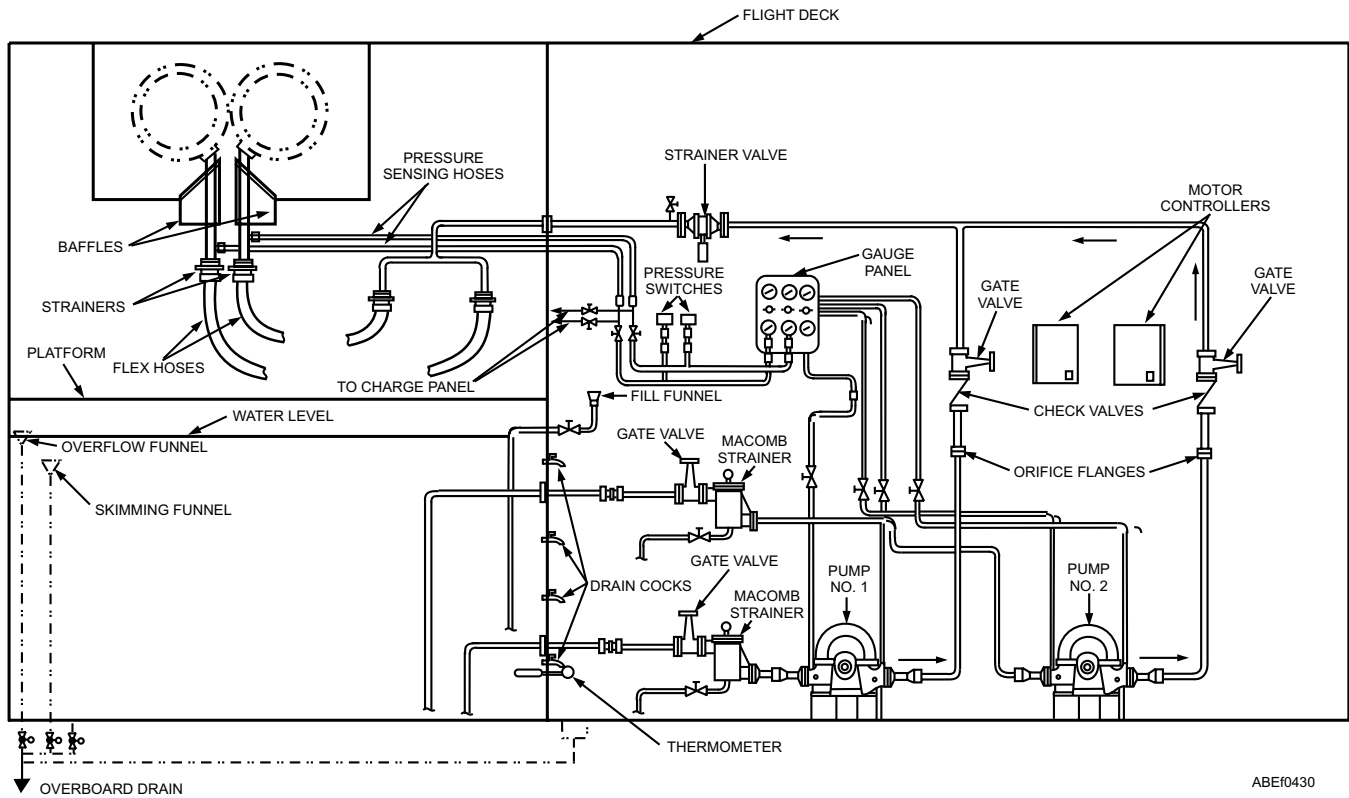

Figure 4-29.—Water-brake piping and pressure switch installation.

STEAM CUTOFF PRESSURE-SWITCH INSTALLATION

The steam cutoff switch installation (fig. 4-30) consists of two pressure switches and associated piping mounted in an intrusion-proof enclosure. The steam cutoff pressure-switch installation is located at a point in the catapult power stroke determined during the catapult certification program. Flexible tubing connects the steam cutoff pressure switch assembly to a port in one of the launching engine cylinders. After the catapult is fired, when the launching engine piston passes the port that is connected to the cutoff switches, steam pressure actuates each switch. This initiates the

launch complete phase of operation and the subsequent closing of the launch valve. The pressure switches are preset to close at an increasing pressure of approximately 20 psi and open at decreasing pressure of approximately 10 psi.

CATAPULT TROUGH INSTALLATION

The catapult trough installation (fig. 4-31) provides a means of covering the catapult trough and providing a track within which the shuttle and grab rollers ride. In addition, it covers the launching engine components and seals the launch valve area from fluid spills and debris.

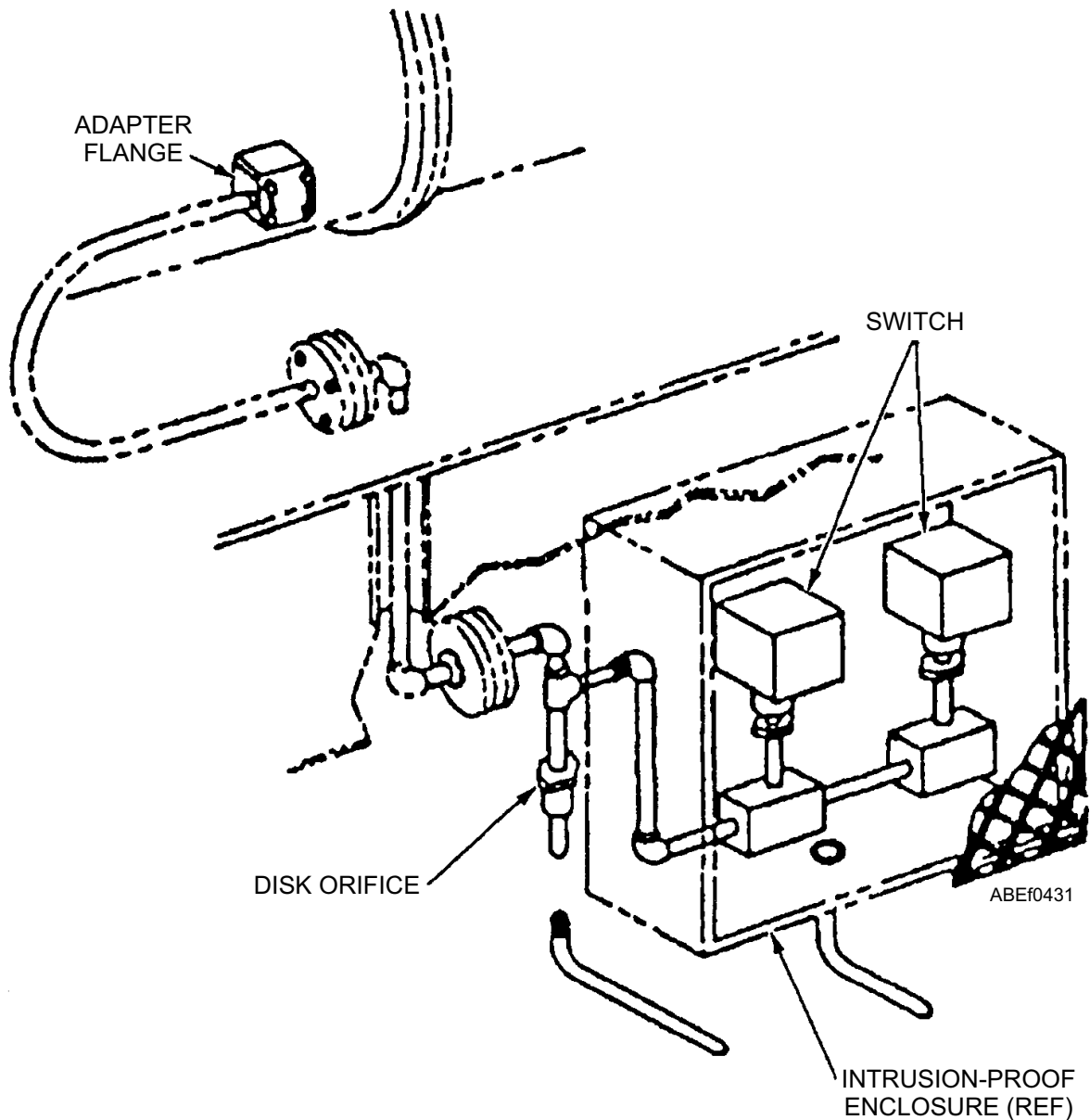

Figure 4-30.—Steam cutoff pressure switches.

Aft Portable Trough Cover

The aft portable cover or Flush Deck Nose Gear Launch (FDNGL) cover, covers the launch valve area and houses the bridle tensioner cylinder and NGL unit. Access covers are provided for the bridle tensioner hydraulic lines.

Shroud and Periphery Drain

On most ships, a shroud and periphery drain assembly is installed directly below the FDNGL cover and on top of the launch valve to further protect the launch valve and its associated piping from corrosion

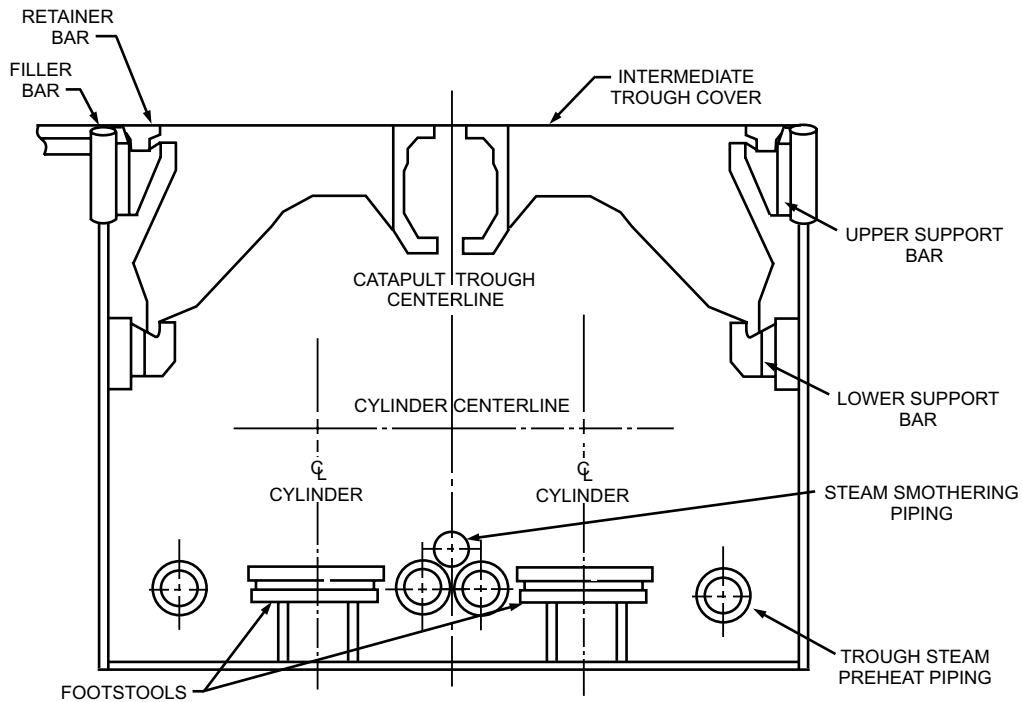

TROUGH, FORWARD OF STATION 0 (TYPICAL)

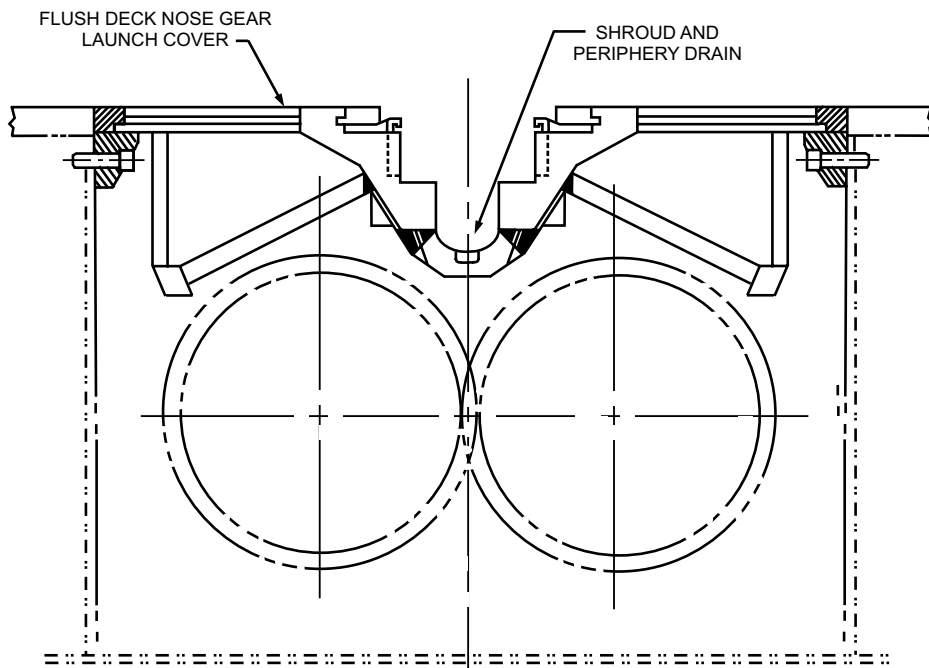

TROUGH, AFT OF STATION 0 (TYPICAL)

ABEf0432

Figure 4-31.—Catapult trough installation.

resulting from water or other fluids leaking past the FDNGL cover.

Intermediate Tough Covers

The intermediate trough covers bridge the catapult trough to provide a smooth continuous flight deck and are manufactured with a track section (channel) which supports and guides the shuttle and grab during catapult operations. All trough covers are designed to withstand a vertical rolling load of 264,000 pounds total (132,000 pounds to each cover) in upward directional force and 100,000 pounds wheel-load in downward directional force. The standard trough covers are made in various lengths.

Forward Trough Covers

The forward trough covers are nothing more than intermediate covers, machined to receive a splash bar to prevent water from splashing up out of the water brake tank when the spears enters the water brakes

Forward Portable Trough Covers

The forward portable trough cover is commonly known as the water brake cover plate. In covers the water brake area and contains access plates to allow for sealing strip tensioner inspection. Slots and attached scales are provided for cylinder expansion indicators.

Upper and Lower Support Bars

The upper and lower support bars are bolted to the catapult trough wall and serve to support and align the trough covers. In addition, the upper support bars provide a means of securing the trough covers in place

Retainer Bars

The retainer bars bolt to and secure the trough covers to the upper support bars

Slots Seals

The slots seals are “T” shaped rubber seals that are installed in the trough cover slots during all non-operation periods. The slot seals aid in maintaining proper catapult cylinder elongation, as well as preventing deck wash, fuel and debris from entering the catapult trough.

Track Slot Buttons

Track slot buttons (fig. 4-32) are provided to prevent the arresting gear purchase cables from falling into catapult number three's trough cover slot during recovery operations. Track slot buttons must be removed prior to any catapult operations

Track Slot Button Installation

1. Removed the button from the designated ready storage area and install 12 buttons at 12 feet intervals beginning with the first button 12 feet forward of catapult position.
2. Insert speed wrench in each button latch capscrew and turn one full turn counter-clockwise. This will align the latches with the button.
3. Place the button in the track slot and turn each latch capscrew clockwise until it is fully tightened. Insure each latch turns to a position perpendicular to the track slot.

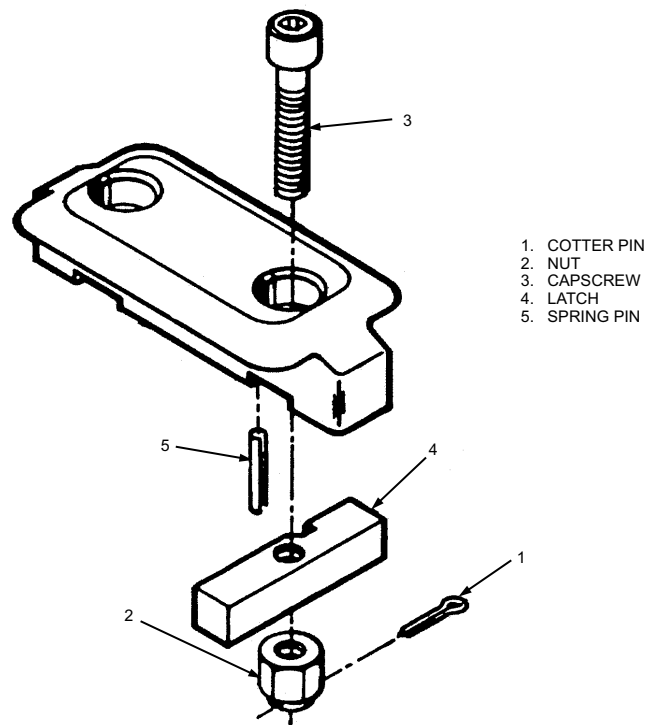

ABE0433

Figure 4-32.—Track slot button.

Track Button Removal

1. Turn the latch capscrew of each button counterclockwise until the latches are aligned with the buttons. The button can then be lifted out of the slot with the speed wrench.
2. Perform a count of the buttons to ensure they have all been removed.
3. Return the buttons to their storage cart and return the cart to their designated storage area.
4. Any missing or damaged button shall be reported to the catapult officer.
5. After the catapult slot has been cleared of buttons, stow the shuttle forward.

Cylinder Expansion Indicator

The cylinder expansion indicators (fig. 4-33) provide a flight deck visual indication of cylinder thermal expansion. There are two expansion indicators, each connected to the forward end of each launching engine cylinder. The indicator support is fastened to the cylinder cover inner male guide, and supports the pointer assembly. The pointers normally extend through slots in the deck, but are spring loaded to prevent damage during deck access cover removal. Recessed in the deck beside each deck slot is a scale with 0.10-inch graduations. The expansion indicators move with the cylinders, and expansion can be measured directly by reading the scale beside the pointer.

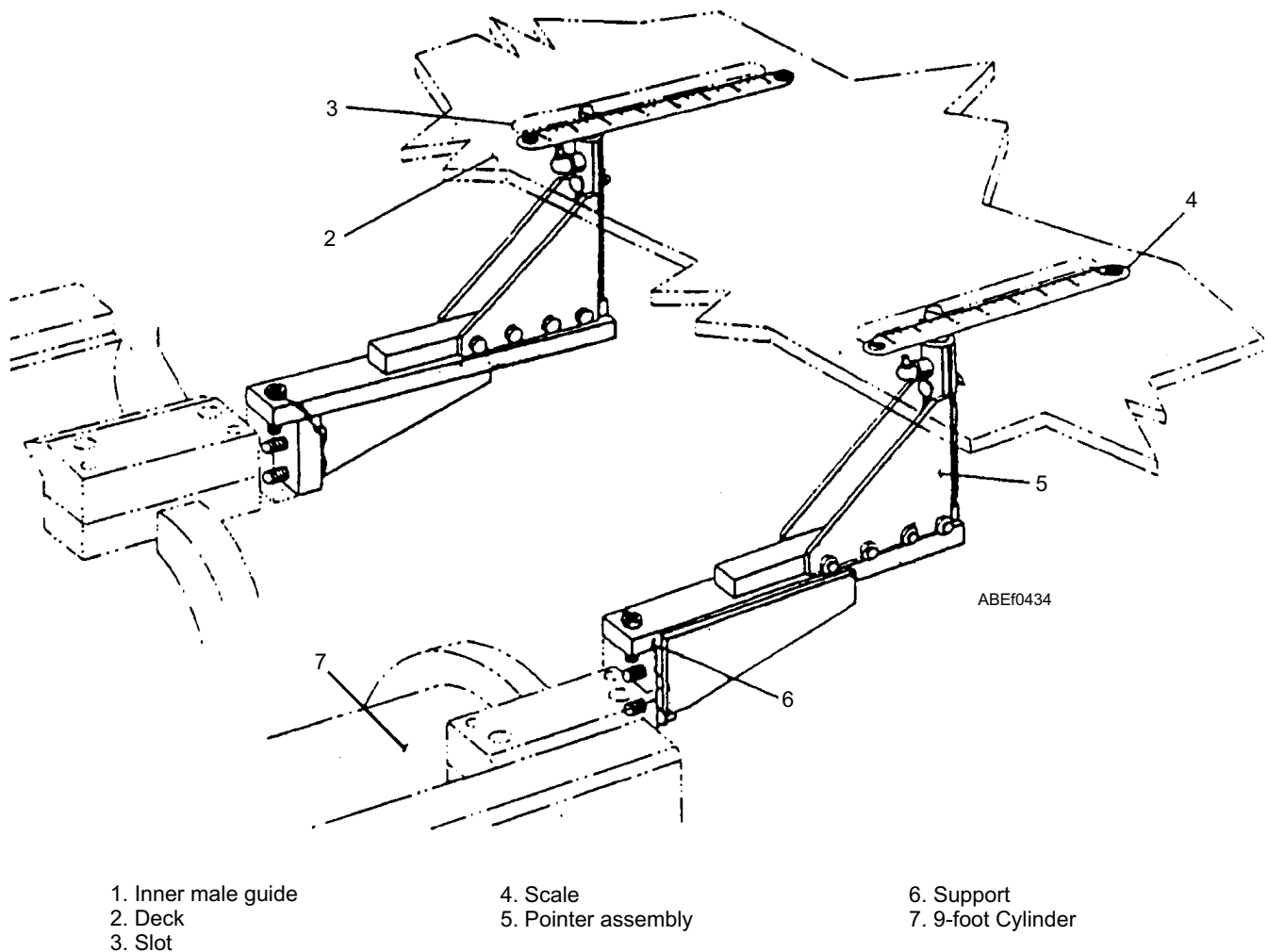

Figure 4-33.—Expansion indicator.

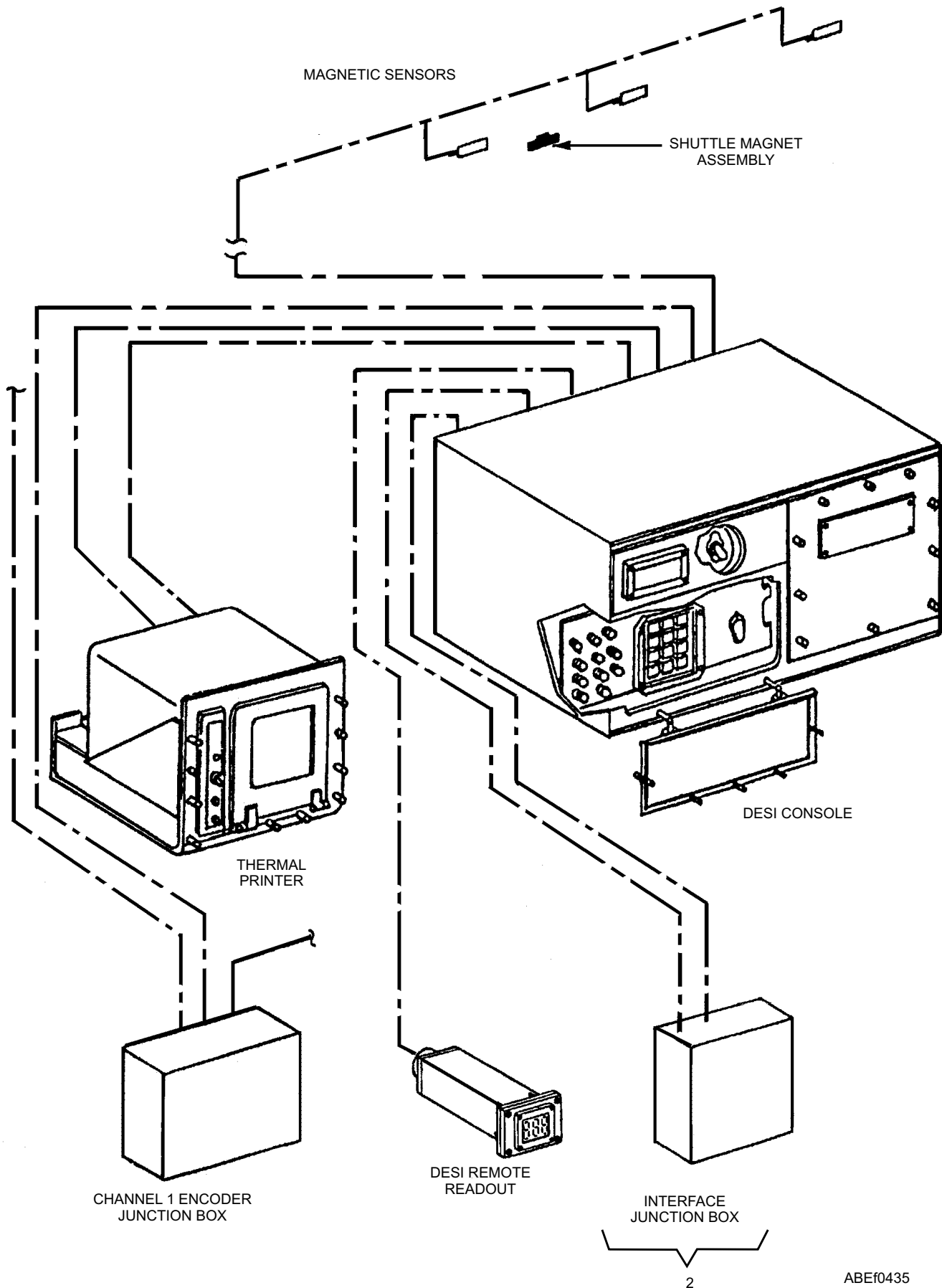

Figure 4-34.—Digital endspeed indicator system.

ABEf0435

Digital Endspeed Indicator System

The Digital Endspeed Indicator System (DESI) (fig. 4-34) provides a means for measuring the endspeed of the steam catapult shuttle during operation. The endspeed is measured when a shuttle-mounted magnet passes three magnetic sensors mounted in the catapult track near the water break end. The endspeed is digitally displayed for visual readout on a console assembly. In addition, on CVN-68 through CVN-76, a remote readout is provided in the catapult officer console. A thermal printer permanently records this along with other information such as Capacity Selector Valve (CSV) setting, date, time, and shot count. For more detailed information on the DESI installation, refer to technical manual NAVAIR 51-15ABE-2.

LUBRICATION SYSTEM

LEARNING OBJECTIVES: Describe the components of the lubrication system. Describe the function of the lubrication system.

The lubrication system (fig. 4-35) provides a means of lubricating the launching engine cylinder and sealing strip prior to firing the catapult, by injecting lubricating oil through the cylinder covers with a spray pattern that ensures even lubrication of the cylinder walls before passage of the launching engine pistons. The major components of the lubrication system consists of the following:

LUBE PUMP MOTOR SET

The lube pump motor set delivers lube oil from the lube tank to the lube side of the metering pumps/injectors. The pump motor is left running continuously during operations.

LUBE STORAGE TANK

The lube storage tank stores lubricating oil for used during operations. The lube oil tank holds approximately 220 gallons and is located in close proximity to the lube pump. The lube oil tank is piped to the ship's lube oil stowage tank, which enables easy and convenient lube oil replenishment.

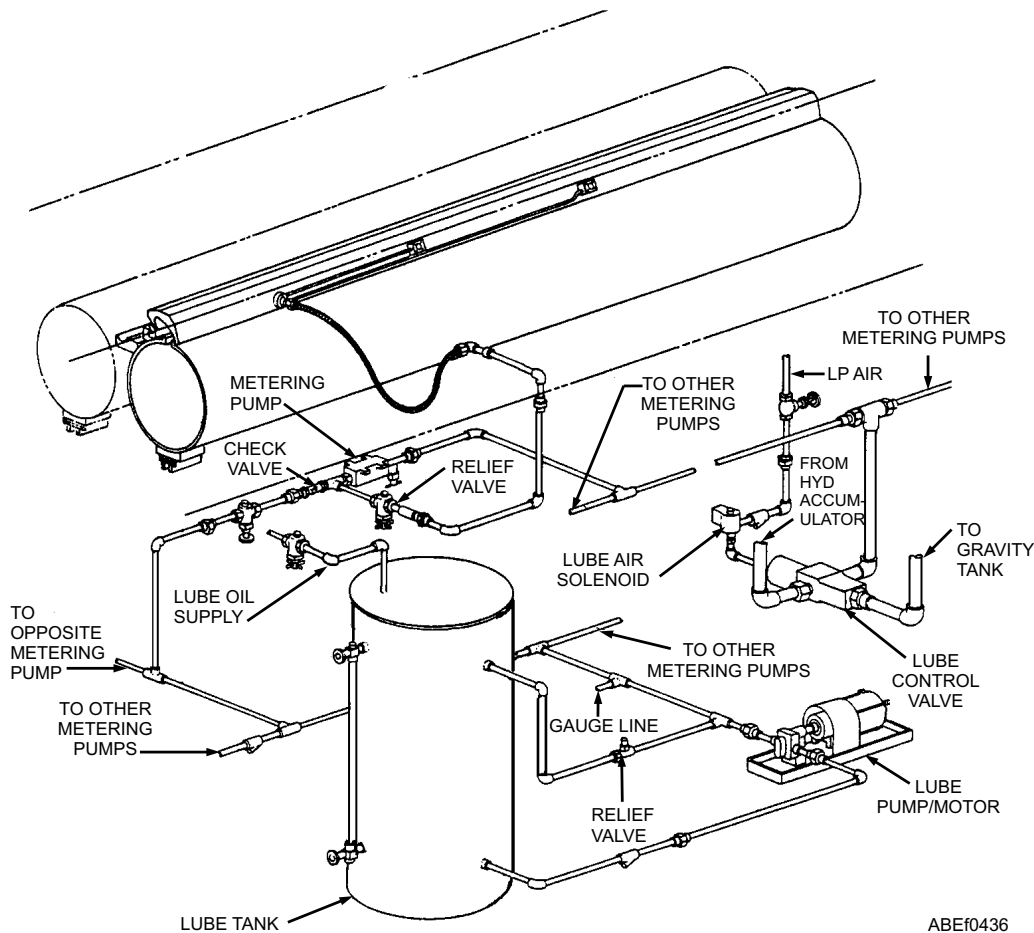

Figure 4-35.—Lubrication system.

AIR-OPERATED LUBE CONTROL VALVE

The lube control valve when actuated, directs accumulator pressure to the high pressure or actuating side of the metering pumps.

AIR-SOLENOID VALVE

The air-solenoid valve, when energized, directs low pressure air to an air cylinder on the lube control valve.

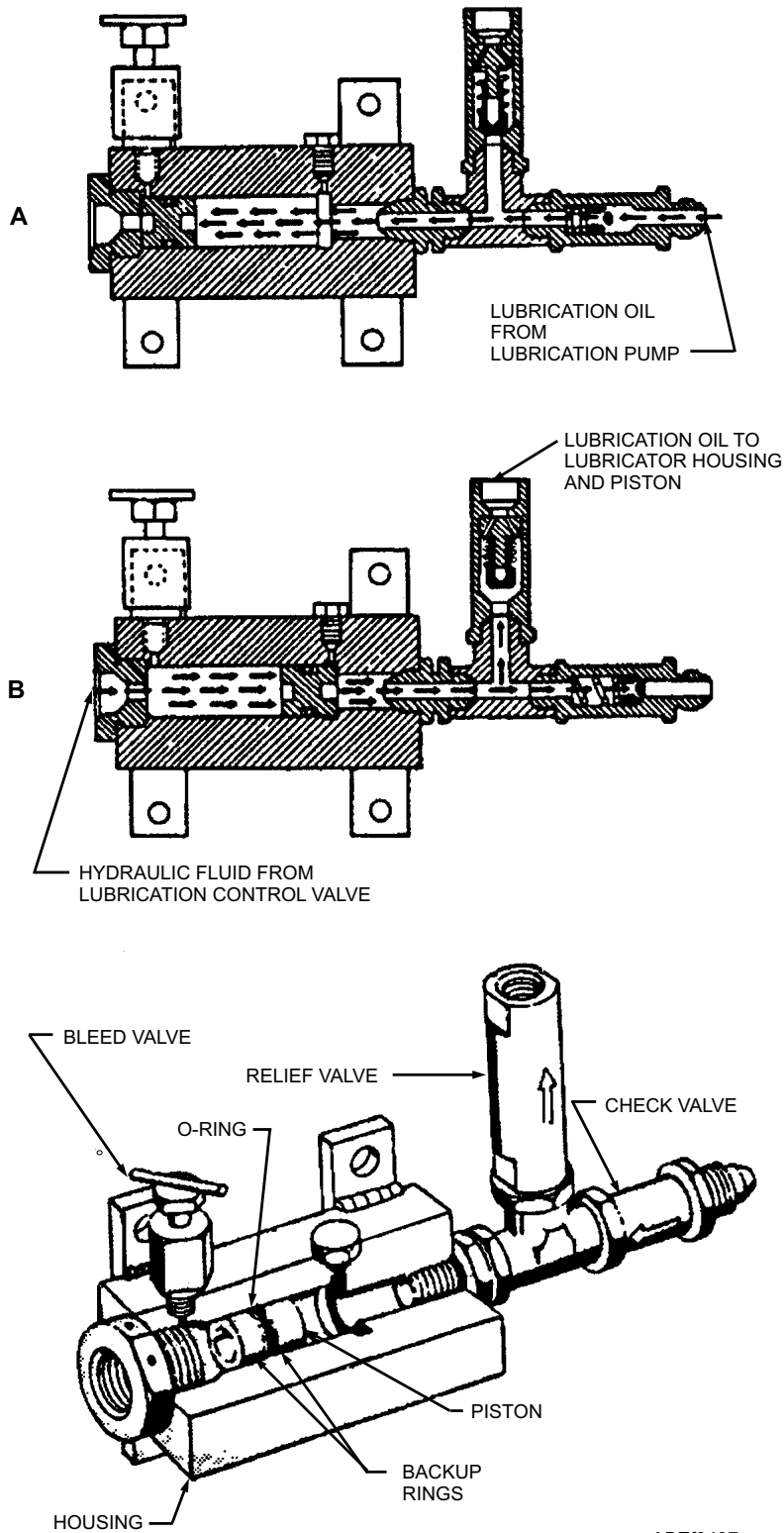

ABEF0437

Figure 4-36.—Metering pump.

METERING PUMPS

The metering pumps distribute lubricating oil to the lubricator housing located on the cylinder covers. Each metering pump contains a piston that separates the metering pump into two chambers, a high-pressure hydraulic chamber and a lube oil chamber.

LUBE OIL SYSTEM OPERATIONS

With the lube air solenoid deenergized, accumulator pressure supplied to the lube control valve, acting on the differential area on the control valve piston will keep the control valve shifted to the air chamber side of the control valve. This allows the high-pressure hydraulic side of the metering pumps (fig. 4-36) to be vented through the control valve to the gravity tank. With the lube pump running, the metering pumps will fill with lube oil. When all metering pumps are full, the lube oil pump discharge pressure will increase to the pump relief valve setting (150-165). Pump discharge will now recirculate to the stowage tank while maintaining relief valve setting pressure throughout the lube oil side of the system.

When the lube air solenoid is energized, it directs low pressure air to the air chamber of the lube control valve, overcoming the unbalanced control valve piston. Low pressure air shifts the control valve allowing accumulator hydraulic pressure to be directed to the high-pressure hydraulic side of all the metering pumps (see fig. 4-36). The lube oil in the metering pumps is forced out through a relief valve and to the two injectors in each of the cylinder covers. One lube injector directs lube oil through the open cylinder slot and the other injector is angled to direct lube oil onto the sealing strip.

BRIDLE TENSIONING SYSTEM

LEARNING OBJECTIVES: Describe the components of the bridle tensioning system. Describe the function of the bridle tensioning system.

The bridle tensioning system (fig. 4-37) provides a means of tightly connecting the aircraft to the shuttle prior to firing the catapult. The bridle tensioning system is comprised of components that directly apply a forward force to the shuttle (external tension) and other

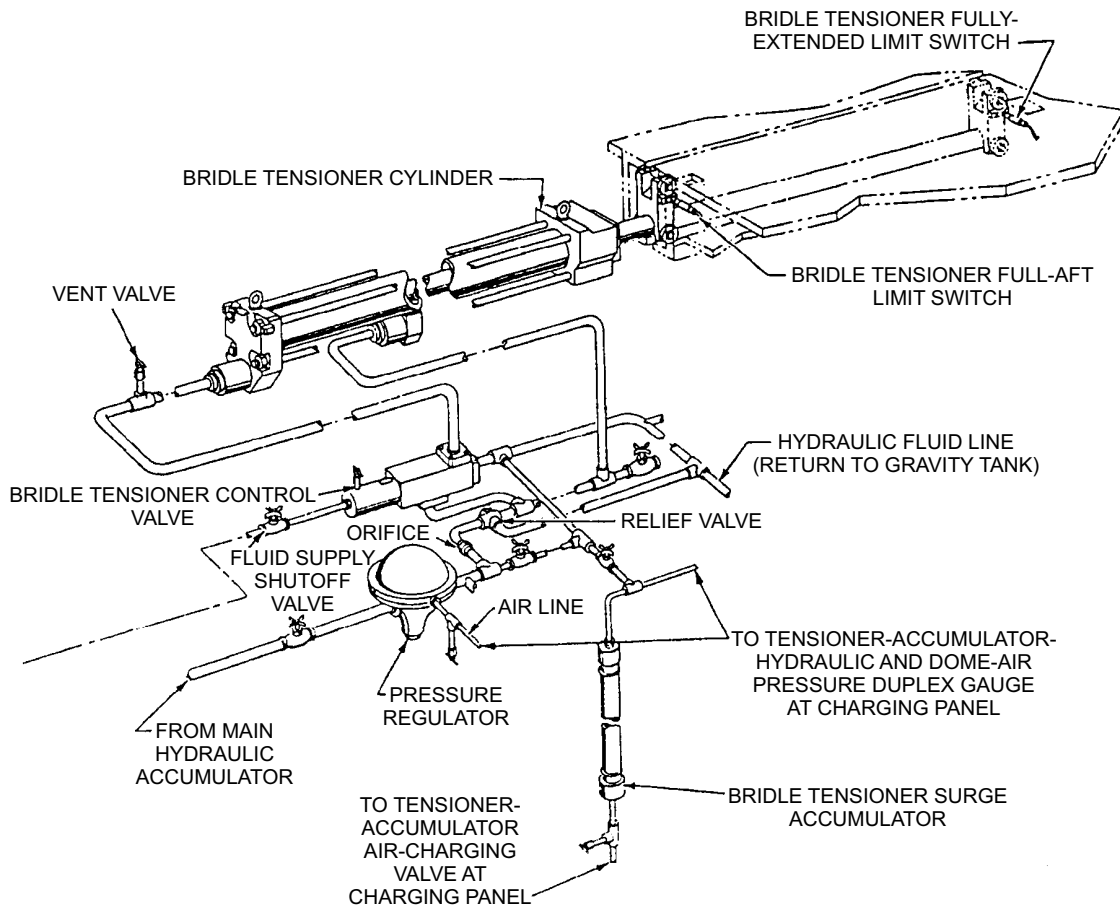

ABER0438

Figure 4-37.—Bridle tensioning system.

components that cause the retraction engine motor to slowly rotate (internal tension). The components of the external tensioning system is comprised of a bridle tensioner pilot valve, a pressure regulator, a tensioner control valve, a tensioner cylinder, a relief valve, and a full aft limit switch.

NOTE

The Mk 2 nose gear launch unit is an integral part of the bridle tensioning system. Its description and operation is discussed later in this manual.

TENSIONER PILOT VALVE

The tensioner pilot valve is located on the retraction engine manifold and is used to actuate the bridle tensioner control valve, internal tensioning inlet, and outlet valve.

PRESSURE REGULATOR

The pressure regulator is used to reduce accumulator pressure to the pressure required for the proper application (4000 plus or minus 250-ft lbs.) through the grab to the shuttle. Reduced pressure from the regulator is directed to the bridle tensioner control valve and to the forward end of the bridle tensioner cylinder.

BRIDLE TENSIONER CONTROL VALVE

The tensioner control valve directs reduced hydraulic pressure from the pressure regulator to the aft

end of the tensioner cylinder during the bridle tension phase. At other times the control valve provides a vent to the gravity tank for the aft end of the tensioner cylinder.

BRIDLE TENSIONER CYLINDER

The purpose of the tensioner cylinder is to exert force on the catapult shuttle, via the shuttle grab assembly, to tension the aircraft launching hardware prior to launching. The bridle tensioner cylinder (fig. 4-38) is mounted directly below the nose gear launch (NGL) track and in line with the aft trough covers. The cylinder contains a piston with a rod extending out of the forward end of the cylinder. The end of the rod is fitted with a crosshead containing rollers, which supports and aligns the piston rod within the track formed by the two trough covers. A cam on the crosshead is used to actuate the bridle tensioner full aft limit switch.

RELIEF VALVE

The external tensioning relief valve is set to relieve at 150 psi over the normally required pressure.

BRIDLE TENSIONER FULL AFT LIMIT SWITCH

The full aft limit switch in the bridle tensioning system is located in the aftermost trough cover, and are actuated by a cam on the bridle tensioner piston rod crosshead. The fully aft limit switch, when actuated, allows completion of the RETRACT PERMISSIVE circuit. This prevents retraction of the grab and shuttle

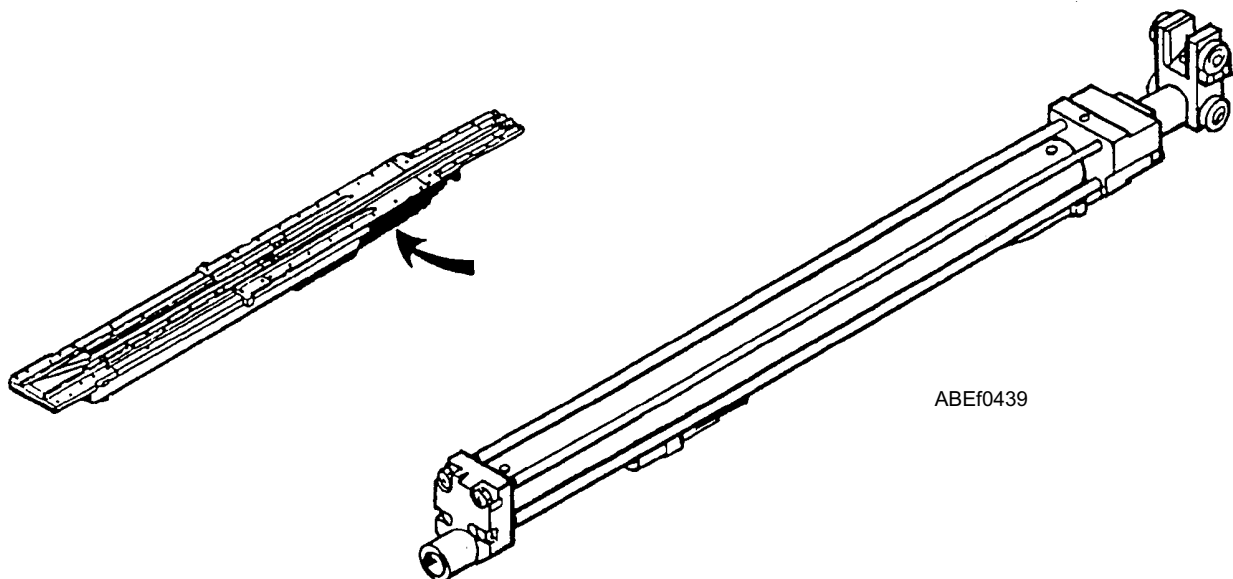

Figure 4-38.—Tensioner cylinder assembly.

into an extended bridle tensioner piston rod. This limit switch is also part of the MANEUVER AFT circuit. This circuit ensures that the tensioner piston rod is fully aft, allowing the grab latch to remain locked to the shuttle in an aircraft-launch-abort situation.

Internal Tensioning Components

The internal tensioning is comprised of components that cause the retraction engine motor to slowly rotate and consists of a pressure regulator, and an inlet and outlet valve.

Pressure Regulator

The pressure regulator is used to reduce accumulator pressure to the pressure required to move the grab and shuttle forward (creep rate) a distance of six feet in 30-50 seconds.

Internal Tensioning Inlet and Outlet Valve

The internal tensioning inlet and outlet valve controls the flow of reduced pressure hydraulic fluid to and from the hydraulic motor and orifice bypass piping during the tensioning phase. When actuated by the

bridle tensioner pilot valve, reduced pressure hydraulic fluid flows through the inlet valve to the hydraulic motor and orifice bypass piping. Hydraulic fluid from the motor and bypass piping is routed to the gravity tank through the outlet valve. This enables the hydraulic motor to rotate the drum slowly so that static friction in the retraction engine and drive system is overcome.

Internal Tension Relief Valve

The relief valve is set to relieve at 225 psi over the normal internal tension pressure.

HYDRAULIC SYSTEM

LEARNING OBJECTIVES: Describe the components of the hydraulic system. Describe the function of the hydraulic system.

The hydraulic system (fig. 4-39) supplies pressurized fluid to the hydraulic components of the catapult. The system consists of a main hydraulic accumulator, an air flask, three main hydraulic pumps, a booster pump and filter unit, a gravity tank, a 90 gallon auxiliary tank, and a circulating pump.

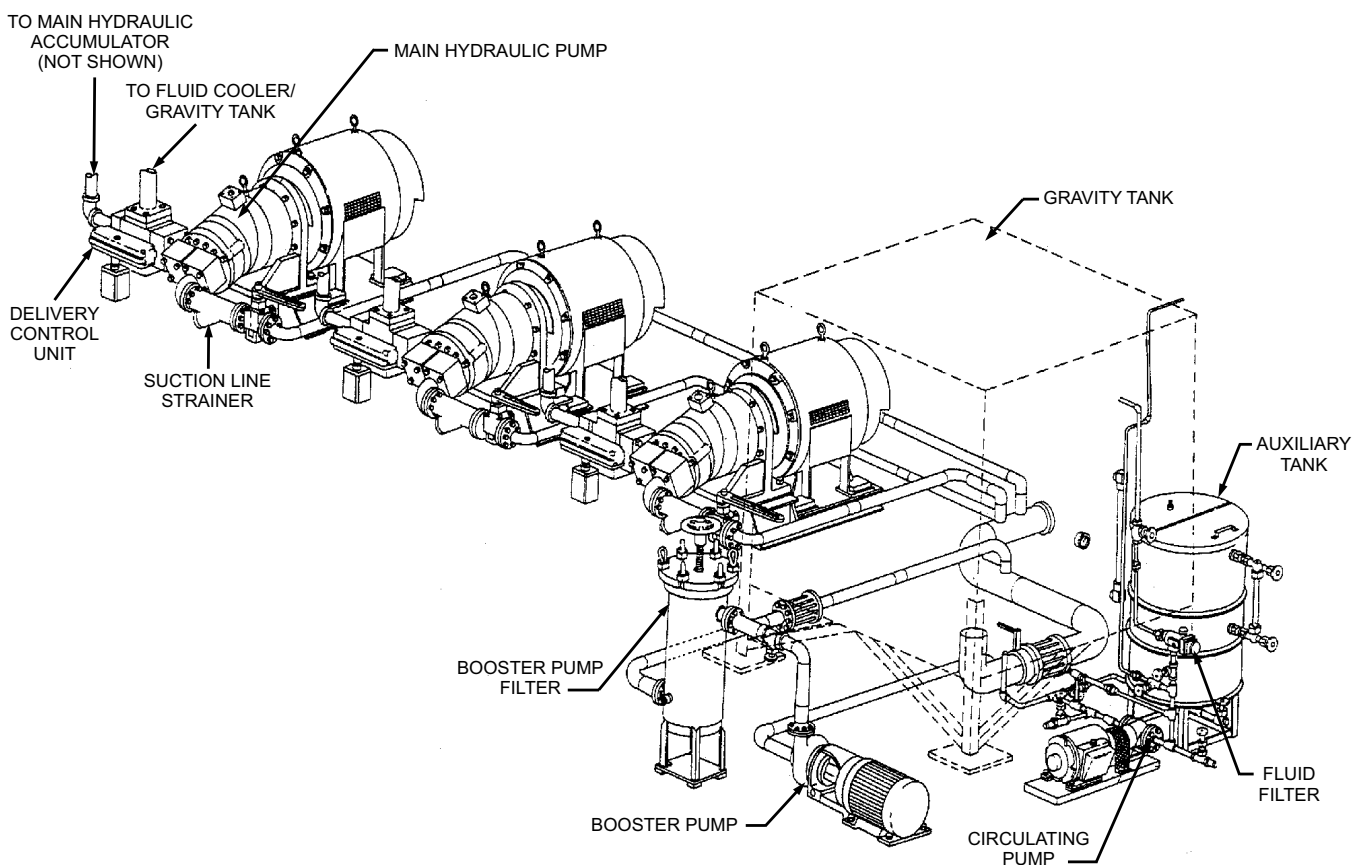

ABE0440

Figure 4-39.—Retraction engine hydraulic system.

HYDRAULIC FLUID

The hydraulic fluid, MIL-H-22072, is 50 percent water, which provides its fire resistance. The remaining 50 percent is composed of a water-soluble polymer, which increases the viscosity of the water, the freezing point depressant, and selected additives that impart lubricant and corrosion protection. The red dye additive provides good visibility for leak detection. With use, the fluid loses water and volatile inhibitors. Water loss is indicated by an increase in the fluid viscosity. Loss of inhibitors is indicated by a change in the pH number of the fluid. (External contamination will also cause a change in pH number.) Normal values for the viscosity and pH number of the unused fluid are as follows:

- Viscosity (fluid temp. 100°F): 185 to 210 SSU
- pH number: 8.8 to 9.8

MAIN HYDRAULIC ACCUMULATOR

The main hydraulic accumulator (fig. 4-40) consists of a vertical cylinder and a floating piston. The piston separates the accumulator into two chambers, a fluid chamber on top and an air chamber on the bottom.

The accumulator provides hydraulic fluid under controlled pressure to all hydraulically operated catapult components. The bottom chamber of the accumulator connects by piping to the air flask and the top chamber is connected by piping to the hydraulic system. A stroke control actuator provides the means of controlling main hydraulic pump delivery as required. A volume normal actuator mounted to the top flange provides protection from operating the catapult if the fluid volume is low.

STROKE-CONTROL ACTUATOR

The stroke-control actuator is mounted near the bottom of the main hydraulic accumulator cylinder. The actuator is a lever-operated cam that operates two limit switches. The bottom limit switch controls the operation of the primary pump, and the top limit switch controls the operation of the remaining two pumps. With the accumulator full of fluid, both on stroke cams are in the released position, deenergizing all pump delivery control solenoids. As fluid is used, air pressure raises the accumulator piston and the actuator rod move upward. The on stroke cam for the primary pump actuates first and that pump will deliver fluid to the

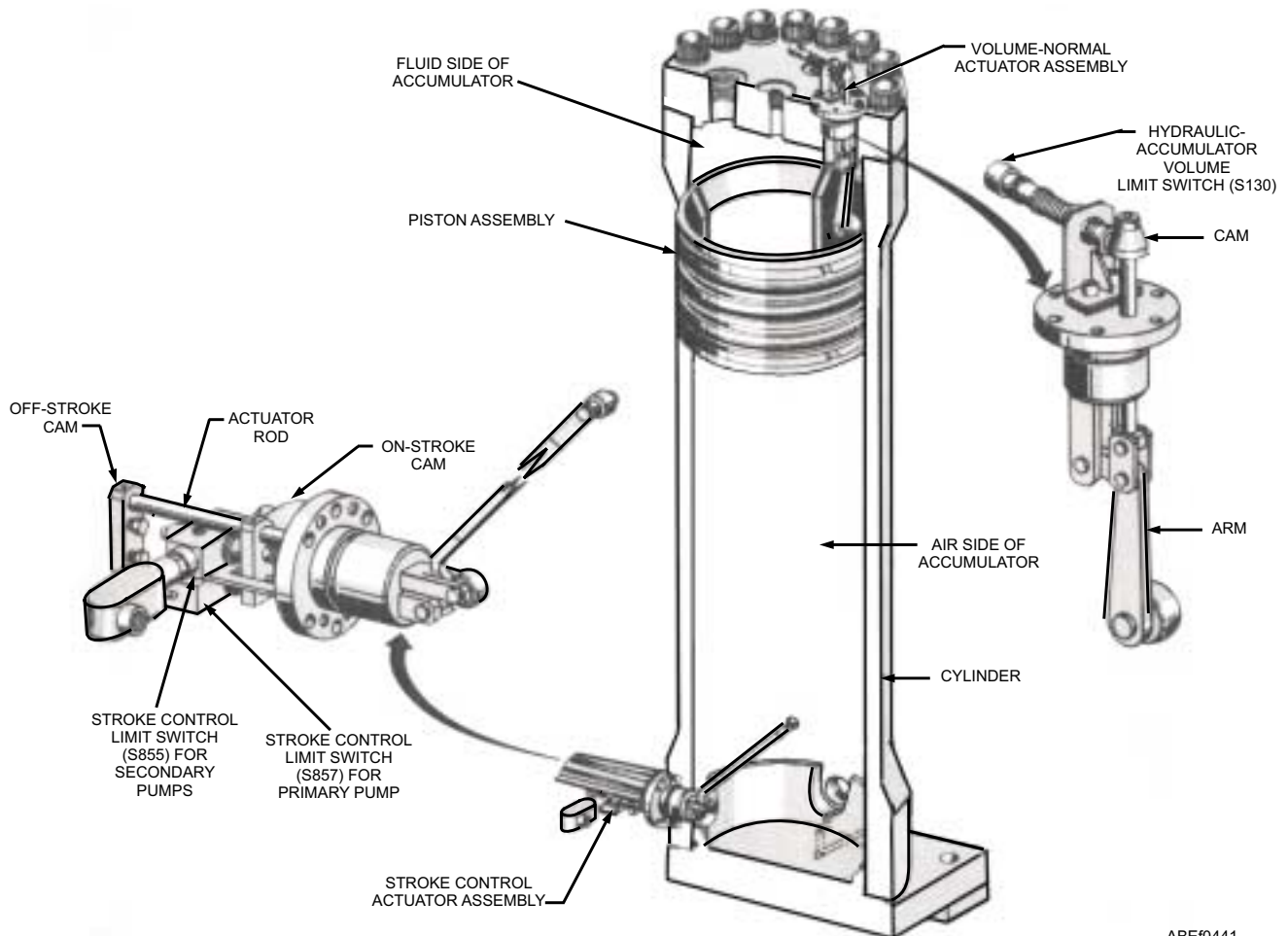

Figure 4-40.—Main hydraulic accumulator.

ABE0441

accumulator. If the system fluid use is in excess of the primary pump output, the accumulator piston will continue to rise causing actuation of the onstroke cam for the other two pumps. The delivery control solenoid of those pumps energizes and all pumps then deliver fluid to the accumulator. As the accumulator fills, the piston move downward reversing the movement of the actuating arm and sequentially opening the circuits to the delivery control solenoids of the three pumps.

VOLUME-NORMAL ACTUATOR

The volume-normal actuator is located in the top of the cylinder (see fig. 4-39). During launching operations, if hydraulic fluid volume in the accumulator becomes dangerously low, the concave top surface on the accumulator piston will come in contact with the arm on the actuator. The arm will rotate and cause the cam to release the limit switch. The limit switch contacts shift, lighting a malfunction light and breaking the circuit to the cat/first ready phase of operation.

AIR FLASK

The air flask (fig. 4-41) is a 70 cubic foot container of compressed air, which is used to maintain nearly constant hydraulic-fluid pressure in the accumulator. As the fluid in the accumulator is used, the air pressure forces the piston upward, displacing the fluid. Because of the large volume of air in the air flask, the pressure change in the accumulator is relatively small.

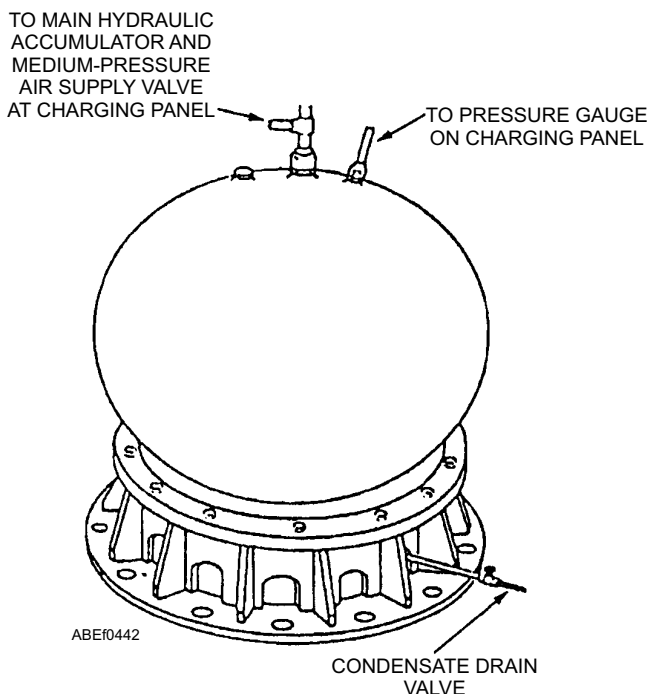

Figure 4-41.—Air flask.

MAIN HYDRAULIC PUMPS

The main hydraulic pumps (see fig. 4-39) deliver hydraulic fluid to the main hydraulic accumulator. The hydraulic pumps are connected in parallel. The intake line to each pump is provided with a strainer. Each pump discharge line is fitted with a delivery control unit, which has a built-in relief valve. When the hydraulic fluid leaves the pumps, the delivery control unit directs it either through a fluid cooler to the gravity tank (pump offstroke), or through the pressure line to the main accumulator. This pressure line is equipped with one-way check valves to prevent the backing up of fluid from the accumulator when the pumps are offstroke.

BOOSTER PUMP AND FILTER UNIT

The booster pump and filter unit (fig. 4-42) consists of a pump and motor assembly and a filter unit installed between the gravity tank and the main hydraulic pumps. The booster pump is operated anytime that a main hydraulic pump is running. During operation the booster pump maintains a positive head of hydraulic pressure at the inlet to the main hydraulic pumps. The filter unit ensures that a clean supply of hydraulic fluid is always available. A means is provided to drain the filter housing to facilitate changing of filter elements. A bypass line, containing a check valve, is installed to permit the main hydraulic pumps to take suction directly from the gravity tank in the event of a clogged filter unit or booster pump failure.

GRAVITY TANK

The gravity tank is the storage reservoir for catapult hydraulic fluid. The tank is made up of internal baffles to minimize fluid surging and foaming. The tank is vented at the top and all low-pressure fluid return lines lead into the top portion of the tank. The tank capacities may vary slightly but the minimum operating tank level with a full hydraulic system and piping is 800 gallons.

AUXILIARY TANK

The auxiliary tank (see fig. 4-39) provides a means to return hydraulic fluid to the gravity tank or replenish with new fluid. The tank consists of a cylindrical shaped container with a top strainer and a lid. A line at the bottom connects to the suction side of the circulating pump. A flexible hose connects the top of the tank to a flight deck fill connection. All new or recycled hydraulic fluid must pass through the auxiliary tank in order to get to the gravity tank.

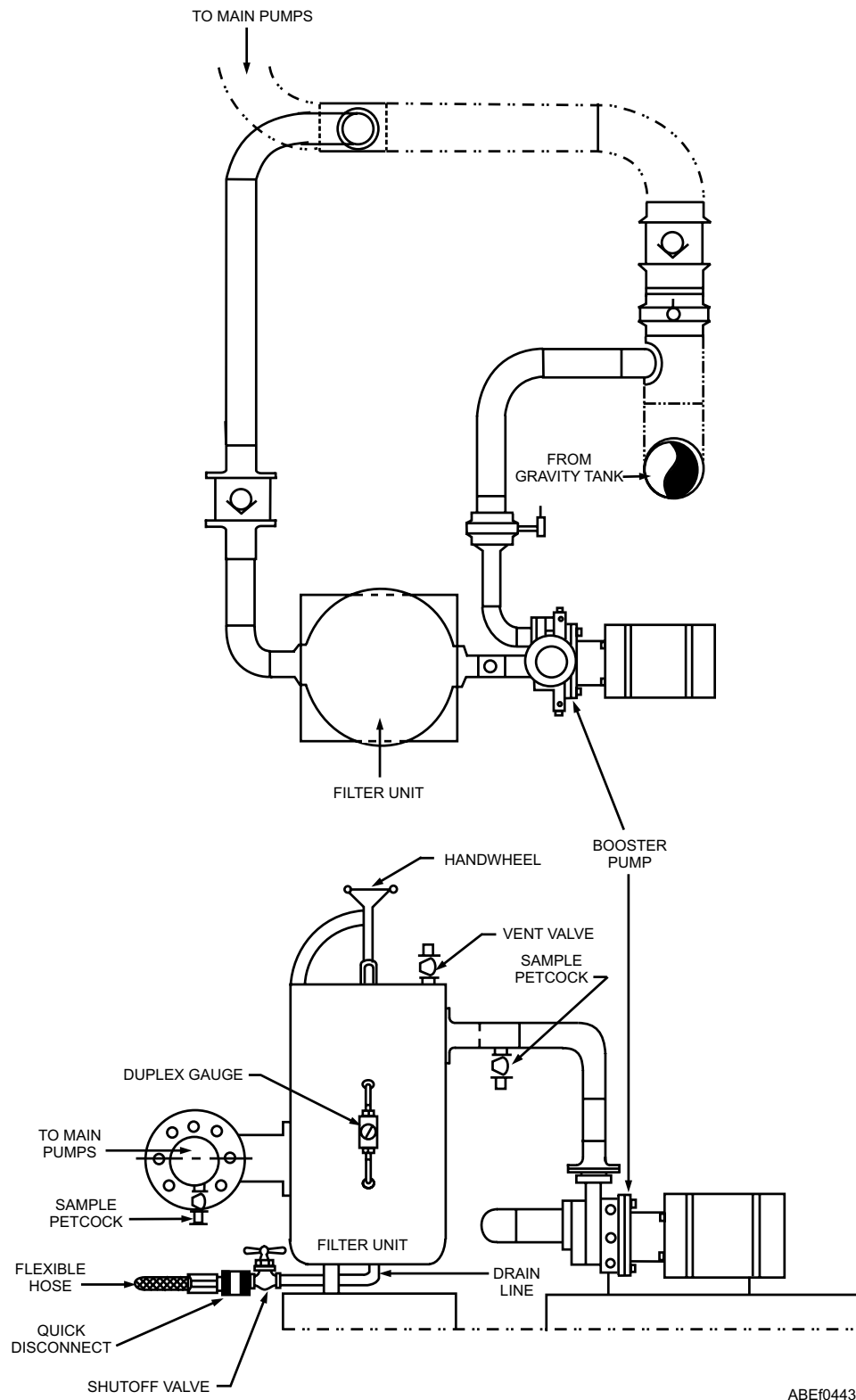

ABEF0443

Figure 4-42.—Booster pump and filter installation.

CIRCULATING PUMP

The circulating pump (see fig. 4-39) is utilized to return hydraulic fluid from the auxiliary tank to the gravity tank. The fluid passes through a filter between

the discharge side of the circulating pump and the gravity tank. This ensures that all new or recycled hydraulic fluid is filtered prior to entering the gravity tank.

RETRACTION ENGINE AND DRIVE SYSTEMS

LEARNING OBJECTIVES: Describe the components of the retraction engine and drive systems. Describe the function of the retraction engine and drive systems

The retraction engine and drive system (fig. 4-43) consists of the components that are used to return the launching engine pistons and shuttle to the battery position after each launch or to maneuver the grab, whenever necessary

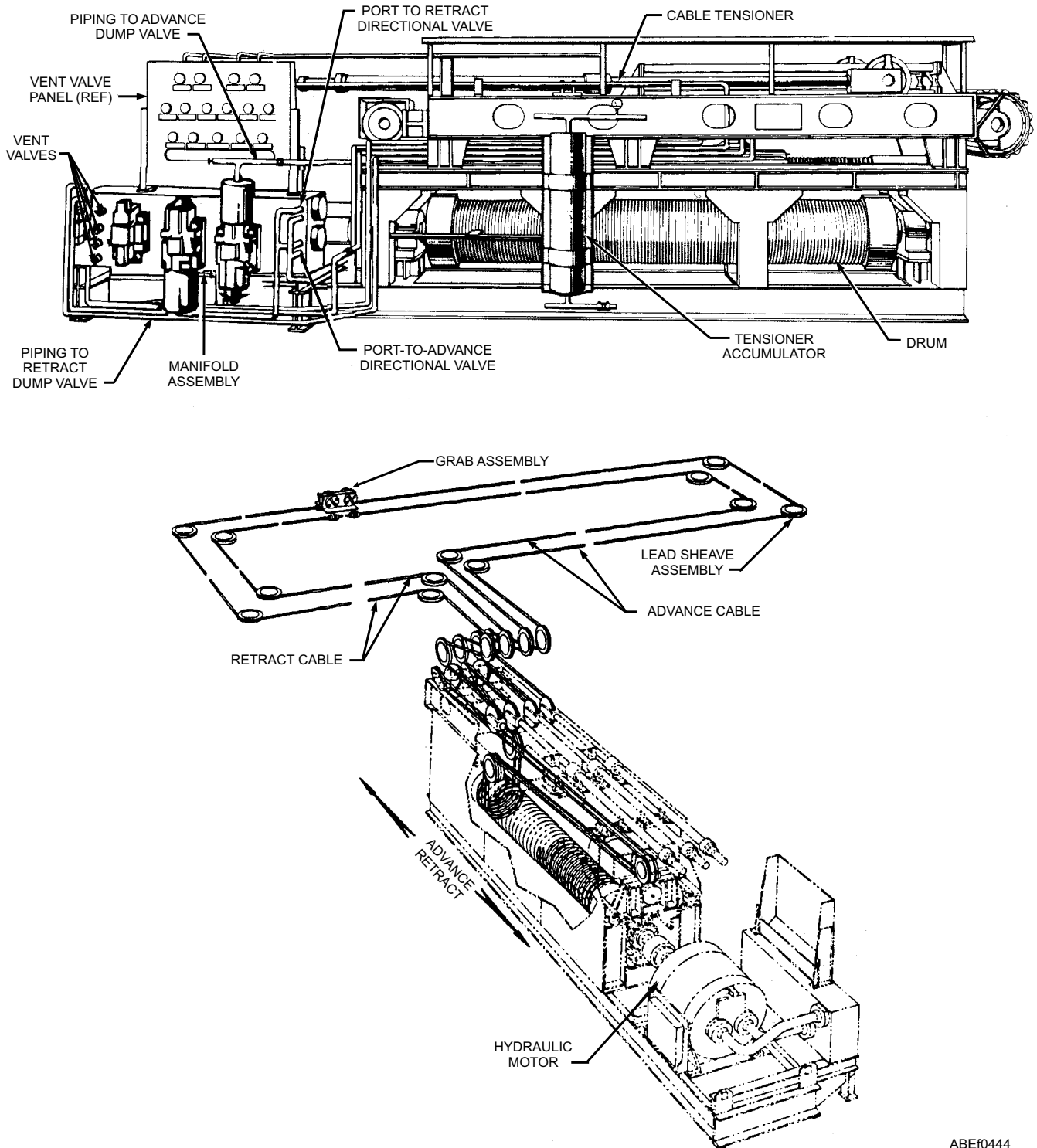

ABEf0444

Figure 4-43.—Retraction engine and drive system.

HYDRAULIC MOTOR

The hydraulic motor (see fig. 4-43) is rotated by pressurized fluid from the main hydraulic accumulator. Various directional valves located on the retraction engine manifold control speed and direction of rotation. The hydraulic motor is coupled directly to the drum assembly, causing the drum to rotate in the same direction and speed as the motor.

DRUM ASSEMBLY

The drum is a grooved, cylindrical shaped assembly which winds and unwinds the drive system cables to either advance or retract the grab, based on directional rotation of the hydraulic motor. The drum is directly coupled to the hydraulic motor and is geared to the screw and traverse carriage installation.

SCREW AND TRAVERSE CARRIAGE INSTALLATION

The screw and traverse carriage installation (fig. 4-44) is mounted on the retraction engine frame above the drum and is driven by a gear arrangement connected to the drum. Rotation of the drum causes the traverse carriage to slide along tracks mounted on the engine frame. A sheave and adapter assembly, bolted to the carriage body, acts as a guide for the advance and retract cables as they wind and unwind on and off the drum preventing the cables from becoming tangled. As the carriage assembly moves along the length of the retraction engine, cams mounted on top of the carriage body come in contact with valves and switches mounted within the retraction engine frame. The cams actuate the advance and retract dump valves, advance and retract cutoff limit switches, grab fully aft limit

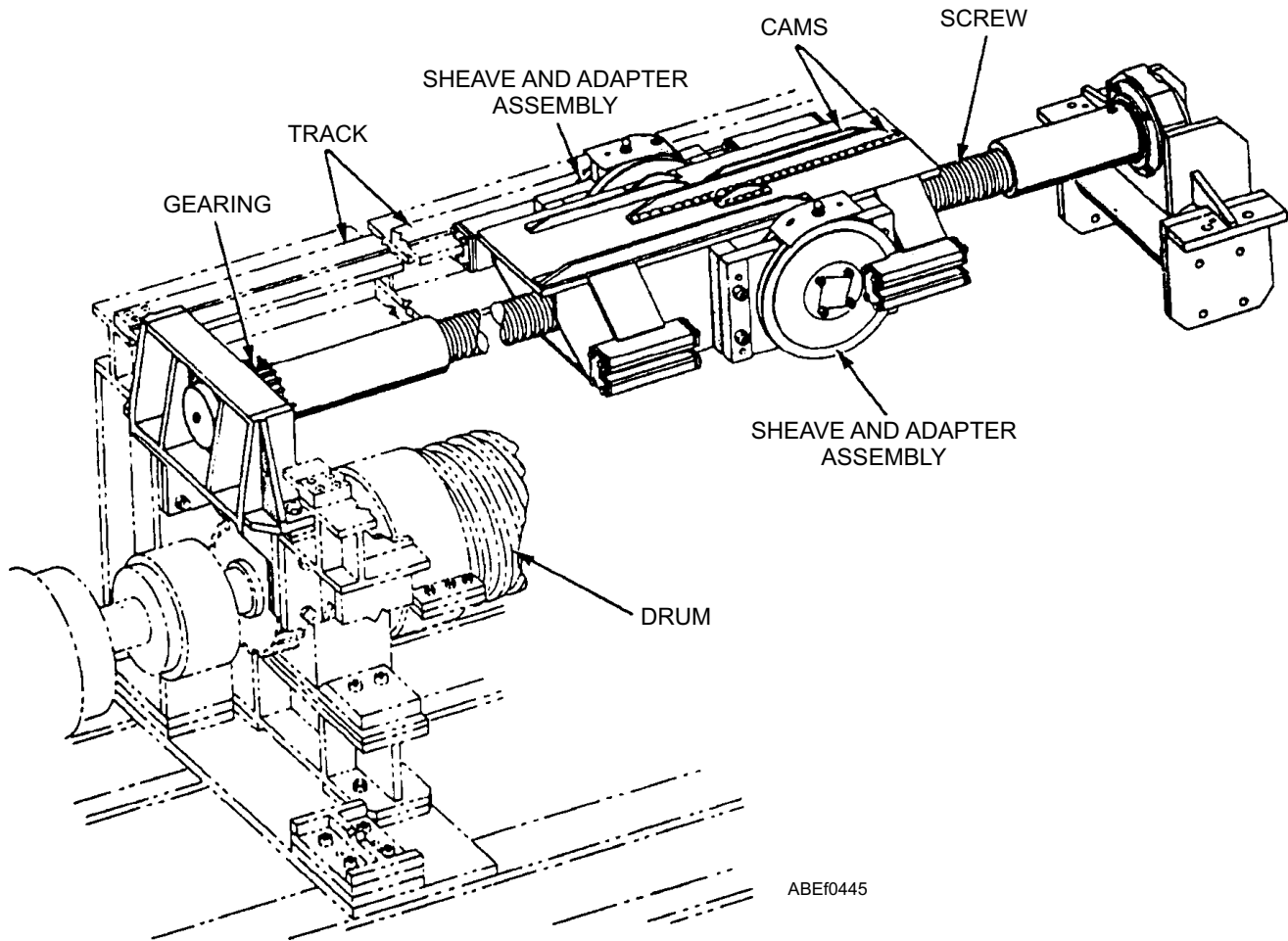

ABE0445

Figure 4-44.—Screw and traverse carriage.

switch, and grab fully advanced limit switch. The cam positions are adjusted for individual installations.

RETRACTION ENGINE MANIFOLD

The retraction engine manifold (fig. 4-45) is mounted on the retraction engine frame and provides internal fluid passages for various control valve functions. The manifold contains the bridle tensioner pilot valve and the internal tensioning inlet and outlet valves for the bridle tensioning system. The manifold also contains the advance and retract pilot valve, retract directional valve, advance directional valve, and maneuvering valve.

ADVANCE AND RETRACT PILOT VALVE

Used to control the advance directional valve and retract directional valve, through the advance dump valve and retract dump valve respectively. When the advance solenoid (SA) is energized, the pilot shifts, directing hydraulic fluid flow through the pilot valve, through the advance dump valve to shift the advance

directional valve. When the retract solenoid (SR) is energized, the pilot shifts, directing hydraulic fluid flow through the pilot valve, through the retract dump valve to shift the retract directional valve

RETRACT DIRECTIONAL VALVE

The retract directional valve (see fig. 4-45) controls the hydraulic motor during retract. When actuated by fluid flow from the pilot valve, the retract directional valve piston shifts, directing fluid flow through the directional valve to the hydraulic motor. The fluid returns from the motor and flows through the directional valve to the gravity tank. When the retract directional valve is not actuated, no fluid flow is allowed through the valve. As the traverse carriage nears the end of a retract stroke, a cam mounted on the carriage actuates the retract dump valve. This drains the pressure in the retract directional valve actuating chamber back to the gravity tank through the dump valve. The retract directional valve piston then closes, causing a gradual cutoff of hydraulic fluid from the hydraulic motor, initiating retraction engine braking.

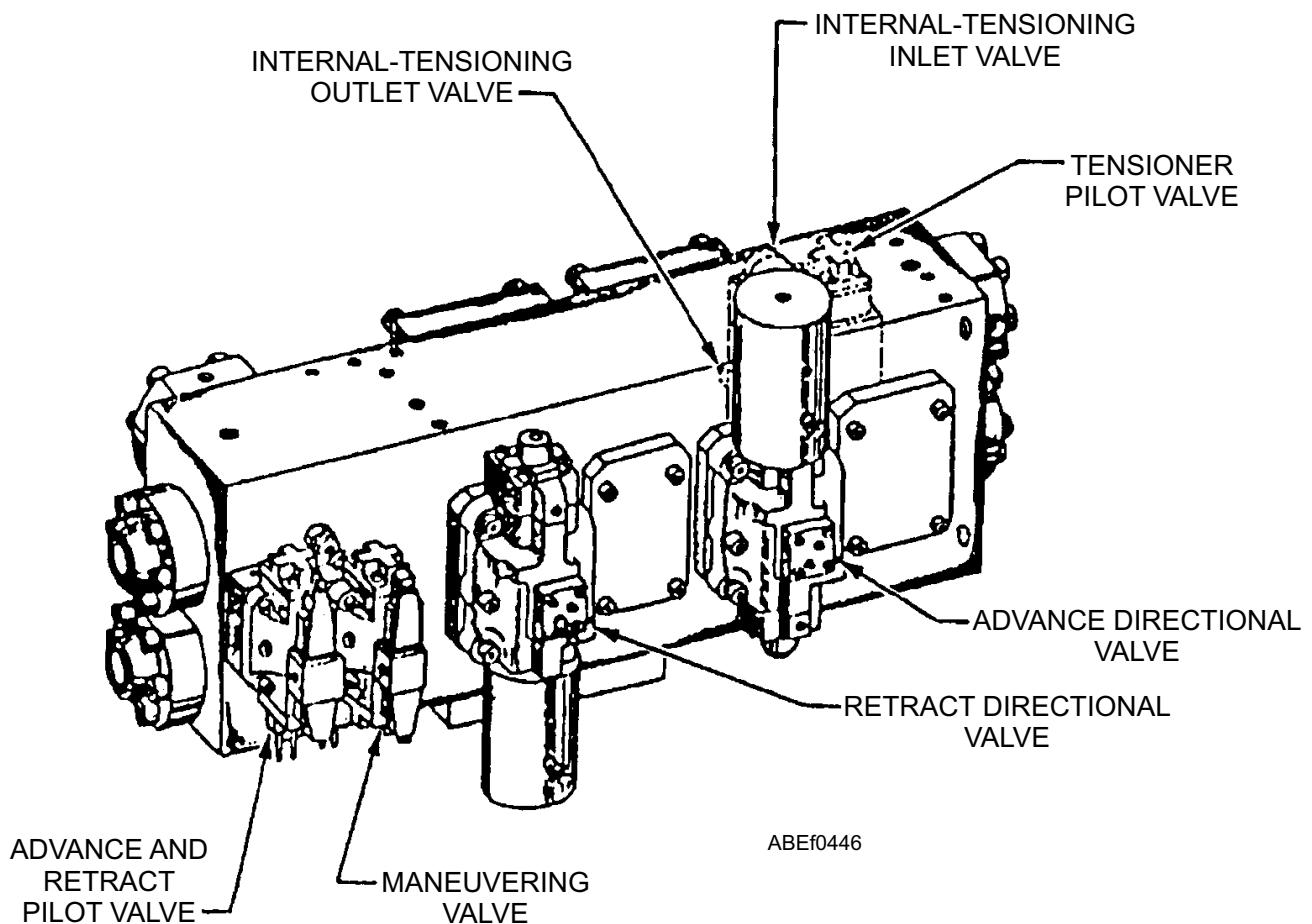

Figure 4-45.—Retraction engine manifold.

ADVANCE DIRECTIONAL VALVE

The advance directional valve (see fig. 4-45) controls the hydraulic motor during advance. When actuated by fluid flow from the pilot valve, the advance directional valve piston shifts, directing fluid flow through the directional valve to the hydraulic motor. The fluid returns from the motor and flows through the directional valve to the gravity tank. When the advance directional valve is not actuated, no fluid flow is allowed through the valve. As the traverse carriage nears the end of an advance stroke, a cam mounted on the carriage actuates the advance dump valve. This drains the pressure in the advance directional valve actuating chamber back to the gravity tank through the dump valve. The advance directional valve piston then closes, causing a gradual cutoff of hydraulic fluid from the hydraulic motor, initiating retraction engine braking.

MANEUVERING VALVE

The maneuvering valve (see fig. 4-45) is mounted on the manifold and is operated by the maneuver

forward solenoid (EF) and the maneuver aft solenoid (EA). The maneuvering valve is energized automatically during the latter part of the advance and retract stroke to control the speed of the grab after braking has been completed. Orifices control hydraulic fluid flowing through the valve to and from the hydraulic motor. At times other than during normal operations, the valve can be energized to slowly maneuver the grab, shuttle, and pistons forward or aft for testing or maintenance. A manual override button on the valve can be pushed to maneuver the grab aft in case of power failure and permit disengagement of the aircraft from the shuttle.

DUMP VALVES

The two dump valves (fig. 4-46) are mounted on the retraction engine frame. The valves are actuated by cams mounted on the traverse carriage. When the retraction engine nears the end of the advance stroke, the advance dump valve is actuated. The dump valve closes allowing the pilot-actuating fluid from the advance directional valve to return to the gravity tank, initiating the advance braking stroke. When the

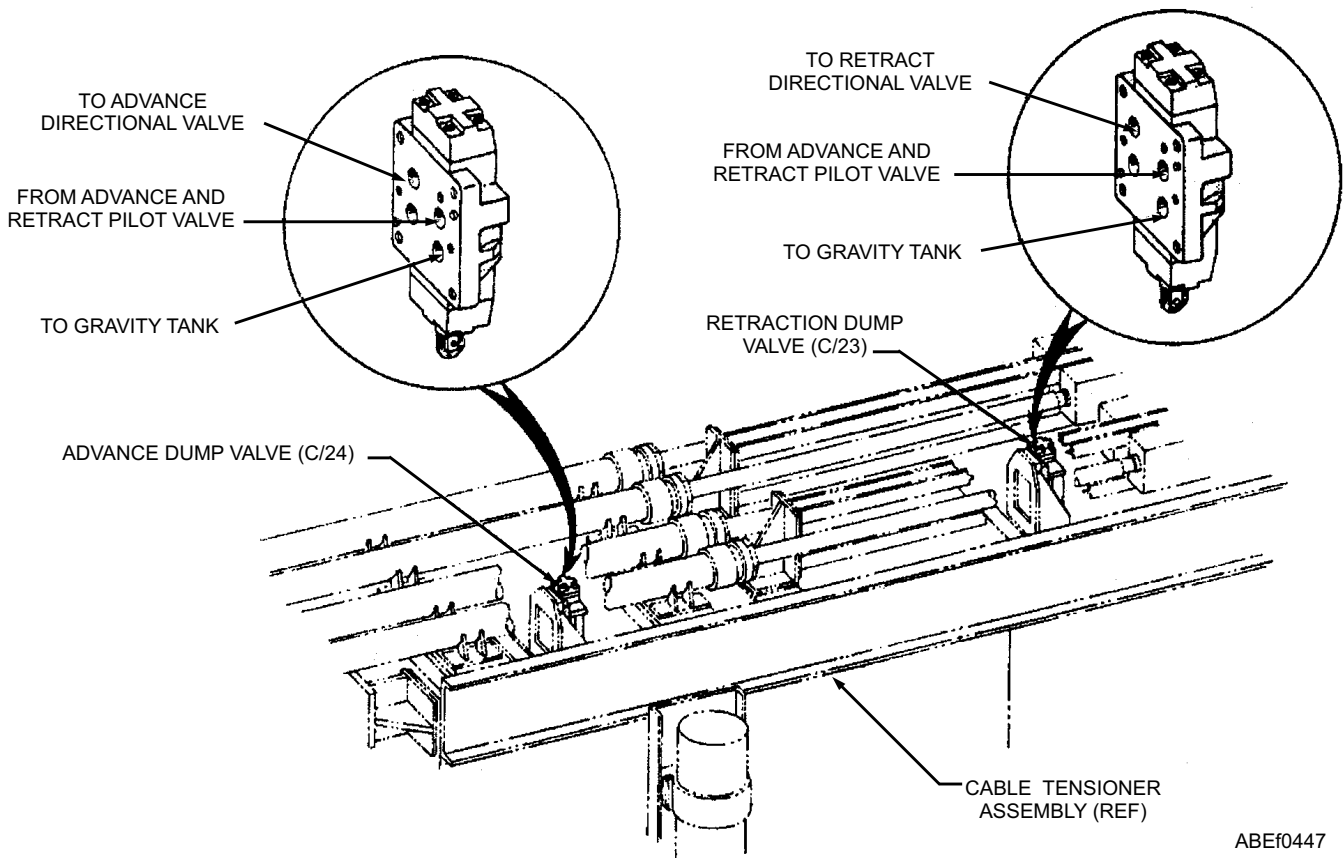

ABEF0447

Figure 4-46.—Retraction engine dump valves.

retraction engine nears the end of the retract stroke, the retract dump valve is actuated. The dump valve closes allowing the pilot-actuating fluid from the retract directional valve to return to the gravity tank, initiating the retract braking stroke.

VENT VALVE PANEL

The vent valve panel is located on top of the retraction engine manifold assembly. Vent valves are mounted on the panel and are connected to various points in the retraction engine hydraulic system. These valves are used to bleed (vent) air and air saturated hydraulic fluid from various retraction engine components. A hydraulic fluid reservoir is located at the bottom of the vent valve panel. The reservoir is used to collect vented fluid and provide the outlet to return vented fluid to the hydraulic system.

CABLE TENSIONER ASSEMBLY

The cable tensioner assembly (fig. 4-47) consists of the four cable tensioners required to keep the retraction engine drive system taut. Each cable tensioner consists of a hydraulic cylinder containing a piston with a threaded rod extending from one end and a rod attaching a clevis/sheave from the other end. Fluid under pressure from the cable tensioner accumulator forces the tensioner sheaves toward the cylinders applying tension to the drive system cables. The threaded rods with adjusting nut on the other end of each tensioner provide a stop for sheave stroke when the pressure in the tensioner cylinders is overcome by the braking action which occurs during dump valve actuation.

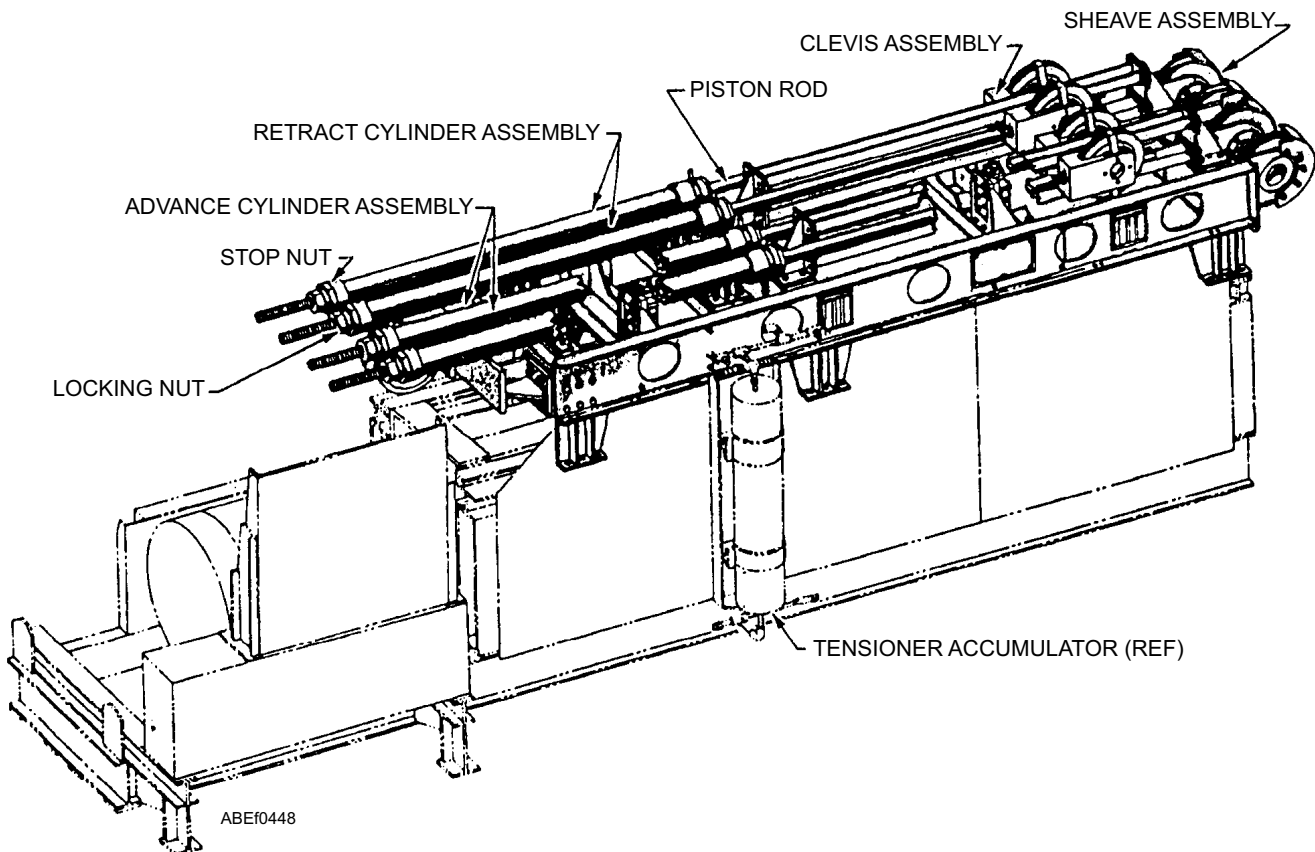

Figure 4-47.—Retraction-engine cable tensioners.

SHEAVES

The sheave assembly (fig. 4-48) is a type of pulley used to guide and change direction of the drive system cables. Sheaves are located on the traverse carriage to feed the cable on and off the drum when the retraction engine is in motion. Fixed sheaves on the retraction engine guide the cables to the fairlead sheaves. The fairlead sheaves are those sheaves that lead the drive system from the retraction engine to the forward and aft ends of the catapult trough.

CABLES

The drive system cables are 9/16-inch wire rope with a swage type fitting on one end for attachment to the grab. Two advance cables and two retract cables attach to the forward and aft end of the grab. The cables are then fairlead to the retraction engine, around the traverse carriage sheaves and then a predetermined length is wound onto the drum. The drum ends of the cables are held in place by bolted clamps. During retraction engine operation, as the drum rotates, one

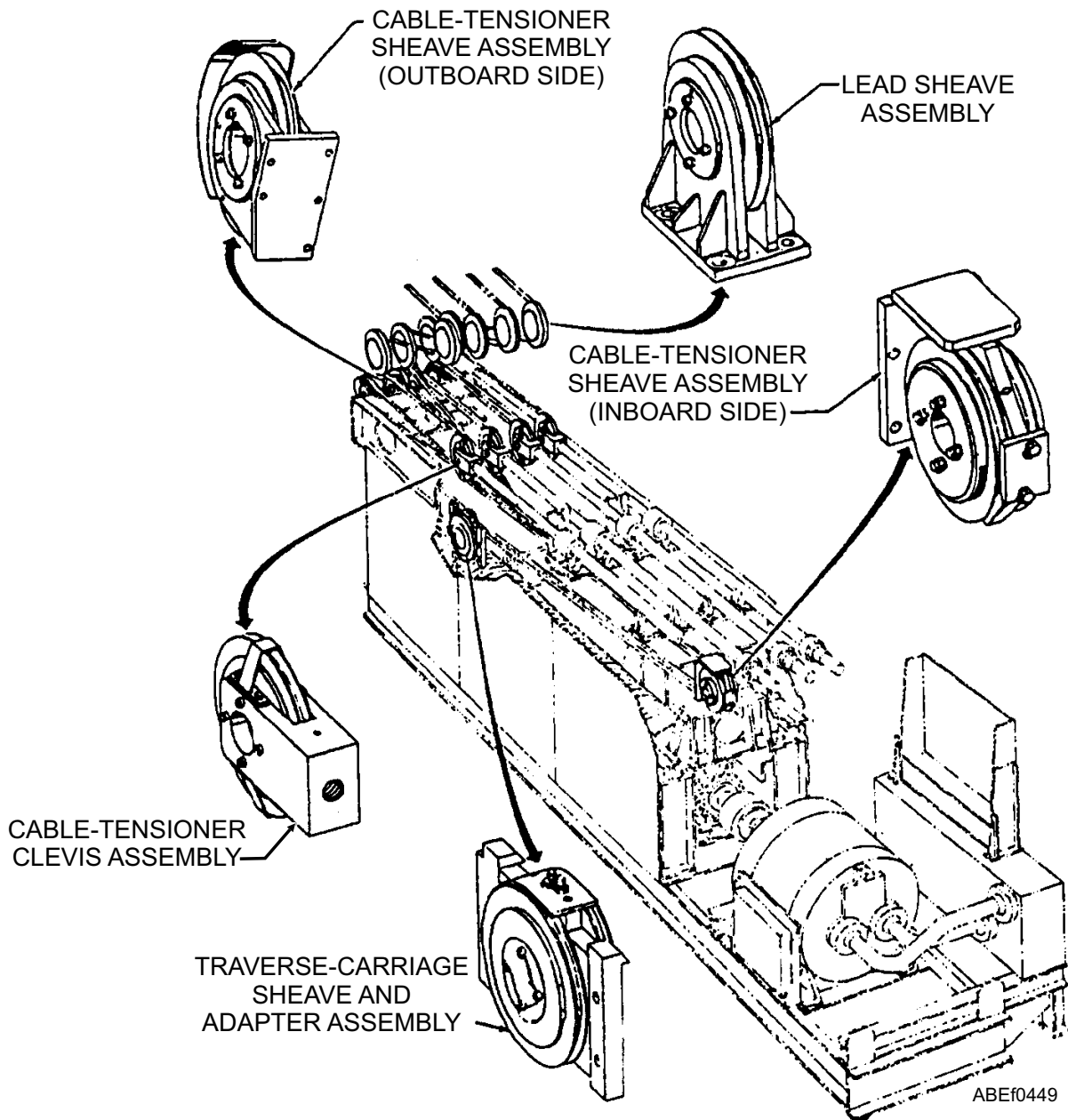

Figure 4-48.—Sheaves.

pair of cables winds onto the drum while towing the grab. The other pair of cables is unwound from the drum by movement of the grab. The traverse carriage moves in proportion with the drum rotation and feed the cables on and off the drum.

GRAB

The grab (fig. 4-49) is a spring-loaded latch, mounted on a wheel frame and installed within the shuttle track behind the shuttle. The two retract cables are fastened to the aft end of the grab, and the two advance cables to the forward end. After a launch, the grab is pulled forward the length of the shuttle track by the drive system, and automatically latches to the shuttle with a positive-locking device. Diagram A of figure 4-50 shows the grab in the UNLOCKED position, approaching the shuttle. When the grab latch (5) comes in contact with the shuttle clevis pin (6), the latch rotates and the latch cam follower (8) moves out of the cam detent (7) in the lock block (9) and continues upward until it reaches the top surface of the lock block. The spring-loaded lock block then moves under the

cam follower, trapping the latch and locking the grab to the shuttle clevis pin, as shown in diagram B. The grab will not release the shuttle until both have been returned to the BATTERY position and the grab unlocking mechanism is actuated by the bridle tensioner. When the bridle-tensioner piston rod moves forward, the bridle-tensioner buffer cap (11) pushes the grab pushrod (1) inward until the buffer cap contacts the grab block (2). When the pushrod is pushed inward, the lock block (9) is pulled from under the latch cam follower and the latch is free to rotate and release the shuttle, as shown in diagram C. When the shuttle and bridle tensioner move away from the grab, the grab remains in the UNLOCKED position, as shown in diagram A. During no-load tests, the grab and shuttle must be unlatched. The grab is manually released from the shuttle, as shown in diagram D. A manual-release disengaging lever (12) is placed over the manual-release arm (3), which is accessible through the track slot, lifted up and pushed forward. This motion pulls the lock block from under the latch cam follower and frees the latch so that the grab and shuttle can be separated.

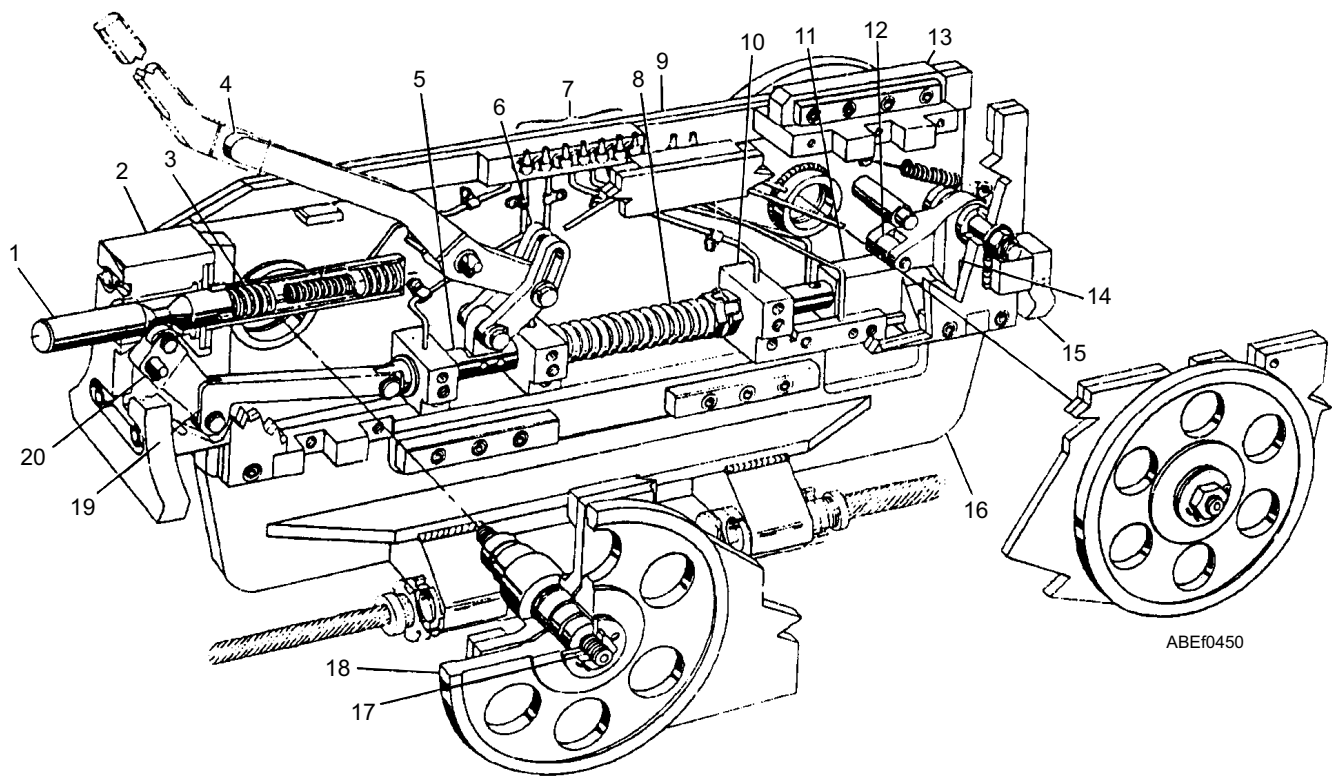

ABE0450

- | | | | |
|-----------------------|------------------------|-----------------------|--------------------|
| 1. Pushrod | 6. Link | 11. Block | 16. Bracket |
| 2. Block | 7. Lubrication fitting | 12. Cam follower | 17. Shaft |
| 3. Spring | 8. Spring | 13. Upper tie bracket | 18. Wheel assembly |
| 4. Manual-release arm | 9. Plate | 14. Latch | 19. Link |
| 5. Slide shaft | 10. Support | 15. Buffer plate | 20. Lever |

Figure 4-49.—Grab.

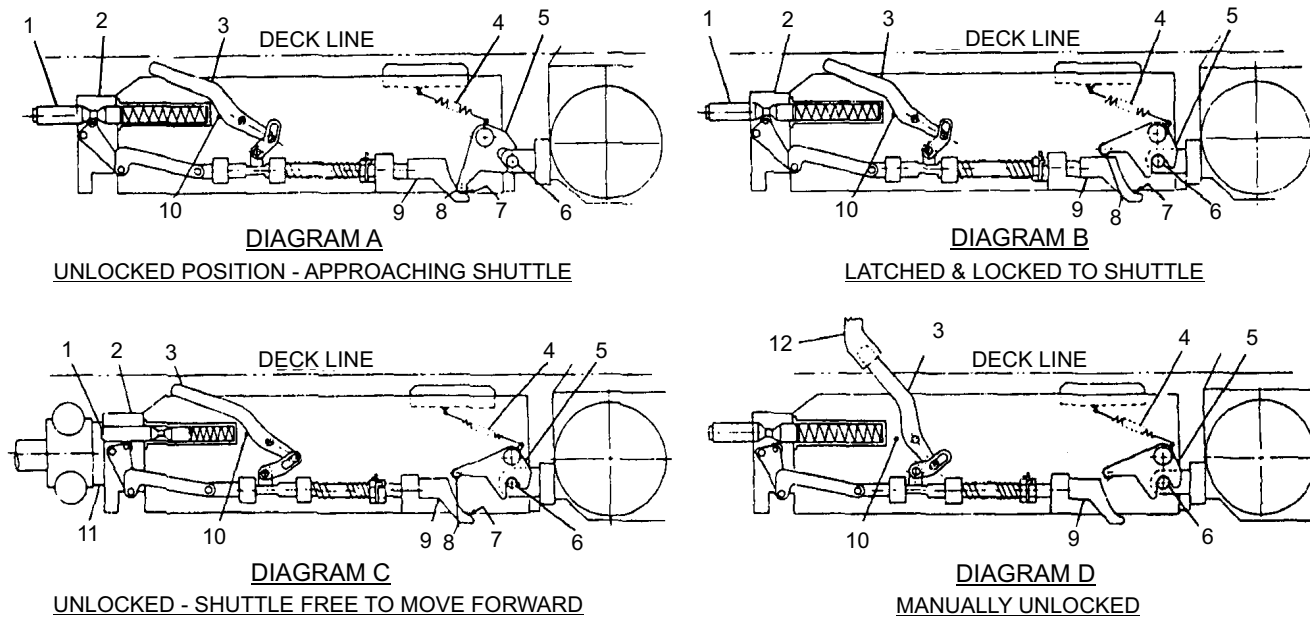

ABE0451

- | | | |
|-----------------------|-----------------------|--------------------------------------|
| 1. Pushrod | 5. Grab latch | 9. Lock block |
| 2. Block | 6. Shuttle clevis pin | 10. Manual-release-arm stop |
| 3. Manual-release arm | 7. Cam detent | 11. Bridle-tensioner buffer cap |
| 4. Latch spring | 8. Cam follower | 12. Manual-release disengaging lever |

Figure 4-50.—Grab operation sequence.

CATAPULT CONTROL SYSTEMS

LEARNING OBJECTIVES: Describe the components of the catapult control systems. Describe the function of the catapult control systems.

The control system of a steam catapult consists of those panels, lights, and switches that are used to operate a catapult throughout the various operational phases.

ELECTRICAL CONTROL SYSTEM COMPONENTS

The electrical control system for a steam catapult consists of various control panels that govern the operation of the catapult in conjunction with control components of other systems.

Included among the components of the catapult electrical control system are various push buttons, switches, solenoids, relays, circuit breakers, fuses, and lights. The ICCS, CCP, and the main control console is the focal point of all functions of the catapult electrical control systems.

Electrically operated solenoid valves produce mechanical operation of valves throughout the catapult. Buttons actuate some solenoid valves, while others

function automatically during catapult operation. Various changes that occur during catapult operation are sensed by limit switches and pressure switches. Operation of these switches actuates lights at various control panels. The following paragraphs briefly describe some of these components. For information on the function and interrelationship of the electrical components in a specific system, study the schematic diagrams in the technical manual for that particular type of catapult.

Solenoids

A solenoid (fig. 4-51) is an electromagnet formed by a conductor wound in a series of loops in the shape of a helix (spiral). Inserted within this spiral or coil are a soft-iron core and a movable plunger. The soft-iron core is pinned or held in position and therefore is not movable. This movable plunger (also soft iron) is held away from the core by a spring in the de-energized position.

When current flows through the conductor, a magnetic field is produced. This field acts in every respect like a permanent magnet having both a north and south pole.

As shown in figure 4-51, the de-energized position of the plunger is partially out of the coil, because of the

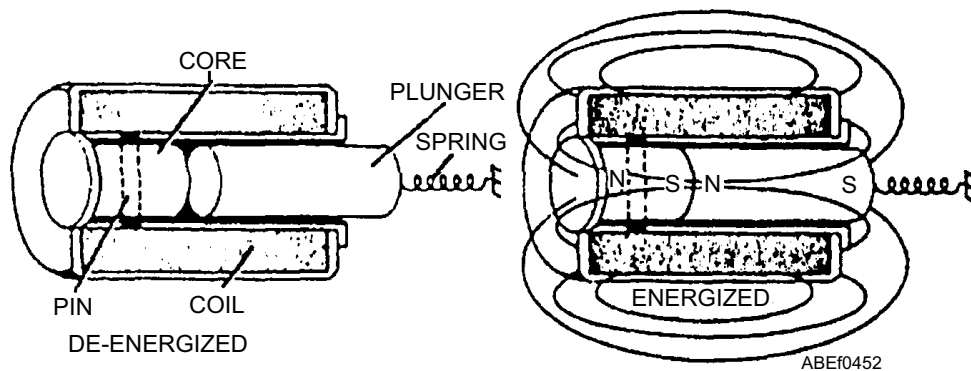

Figure 4-51.—Solenoid.

action of the spring. When voltage is applied, the current through the coil produces a magnetic field, which draws the plunger within the coil, thereby resulting in mechanical motion. When the coil is de-energized, the plunger returns to its normal position by the spring action.

Solenoids are used in steam catapult systems for electrically operating bridle tensioning valves, lubrication valves, engine retraction valves, and relays, and for various other mechanisms where only small movements are required. One of the distinct advantages in the use of solenoids is that a mechanical movement can be accomplished at a considerable distance from the control station. The only link necessary between the control and the solenoid is the electrical wiring for the coil current.

Relays

One of the principal uses of relays is the remote control of circuits. Circuits may be energized by control relays from one or more stations simply by closing a switch. Switches used to energize relays require lightweight wire only, and may thereby eliminate the necessity of running heavy power cable to the various control points. An additional advantage resulting from relay control is the removal of safety hazards, since high-voltage equipment can be switched remotely without danger to the operator.

In general, a relay consists of the following components: a magnetic core and associated coil, the contacts, springs, armature, and the mounting. Figure 4-52 illustrates the fundamental construction of a relay. When the circuit is energized, the flow of current through the coil creates a strong magnetic field, which pulls the armature to a position that closes the contacts. When the coil is energized, it moves the armature to

contact C1, which completes the circuit from the common terminal to C1. At the same time, it has opened the circuit to contact C2.

The relay is one of the most dependable electromechanical devices in use; but like any other mechanical or electrical equipment, relays occasionally wear out or become inoperative for one reason or another. Should inspection determine that a relay has exceeded its safe life, the relay should be removed immediately and replaced with one of the same type.

Fuses And Circuit Breakers

The electrical control system is protected from overloading by fuses and circuit breakers.

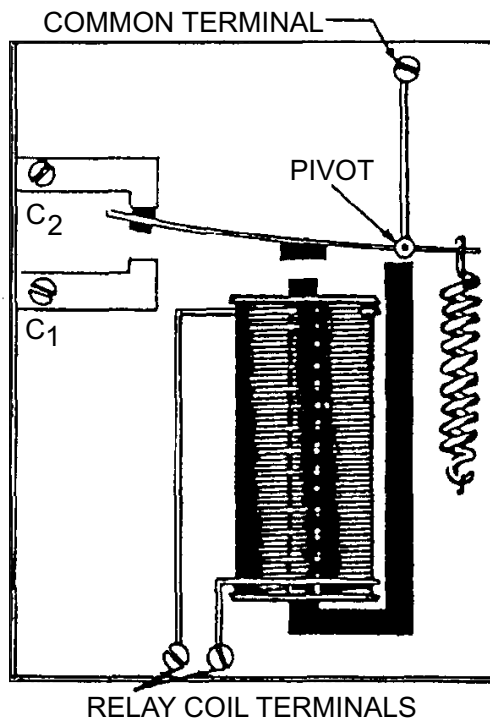

Figure 4-52.—Relay construction.

The fuse is the simplest protective device. A fuse is merely a short length of wire or metal ribbon within a suitable container. This wire or metal ribbon is usually made of an alloy that has a low melting point and is designed to carry a given amount of current indefinitely. A larger current causes the metal to heat and melt, opening the circuit to be protected. In replacing a burned-out fuse, you should be sure that the new fuse is the same size (capacity in amperes) as the original.

The circuit breaker serves the same purpose as the fuse, but it is designed to open the circuit under overload conditions without injury to itself. Thus, the circuit breaker can be used again and again after the overload condition has been corrected.

Limit Switches

Limit switches are used as remote indicators of the position of various components throughout the system. They are actuated mechanically by the movement of the component. Electrical contacts within the switch change the mechanical action to an electrical signal indicated by lights on the various operating panels.

Microswitches

Microswitches serve the same function as limit switches except they are used where a very limited mechanical movement is required (1/16 inch or less). While the term *Microswitch* suggests the function of the switch, it is nothing more than the brand name of the particular type of switch.

PUSH BUTTON CONTROLS

The sequence of operations on the C-13-0, C-13-1, and C-13-2 catapults is controlled by push buttons. The two types of push buttons are the momentary-contact and holding-circuit push buttons. The momentary-contact push button has to be held in the depressed position to keep the particular circuit energized. The maneuver forward and maneuver aft push buttons, are

examples. The push button used in a holding circuit stays energized once it is depressed until that particular circuit is de-energized by the normal sequence of operations or one of the suspend switches is actuated. All the push buttons associated with the normal operation of the catapult are incorporated into holding circuits.

CATAPULT CONTROL SYSTEM FOR CVN-68 THROUGH CVN-76 (INTEGRATED CATAPULT CONTROL STATION (ICCS))

The controls for the ICCS are mainly divided between the ICCS at the flight deck level and the Central Charging Panel (CCP) below deck. The ICCS is an enclosure that may be retracted into the deck when not in use. It contains the catapult-officer control console and the monitor control console, and controls the operation of two adjacent catapults. Sound-powered phones and a system of indicator lights link the ICCS to the remote panels for individual catapults. In an emergency, the functions of the ICCS can be transferred to the emergency deckedge control panel or the central charging panel, and the catapult officer can direct operations on the flight deck.

Catapult-Officer Control Console

The catapult-officer control console (fig. 4-53) is used in conjunction with the monitor control console and the central charging panel to direct catapult operations. The control console is of wraparound design for ease of operation and located facing aft in the ICCS. The console is made up of panels containing all of the lights, switches and other controls necessary for the operation of two adjacent catapults. The operating panels and lower end operating panels contain the lights and switches for operation of the associated catapult. The remaining panels located between the operating panels and lower end operating panels provide the launching officer with all of the other information or switches.

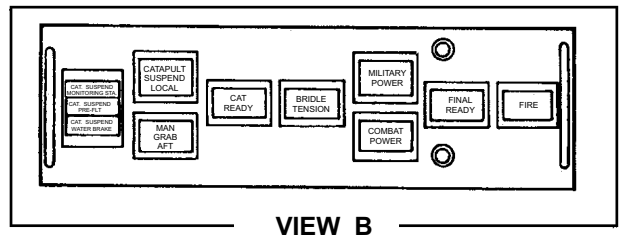
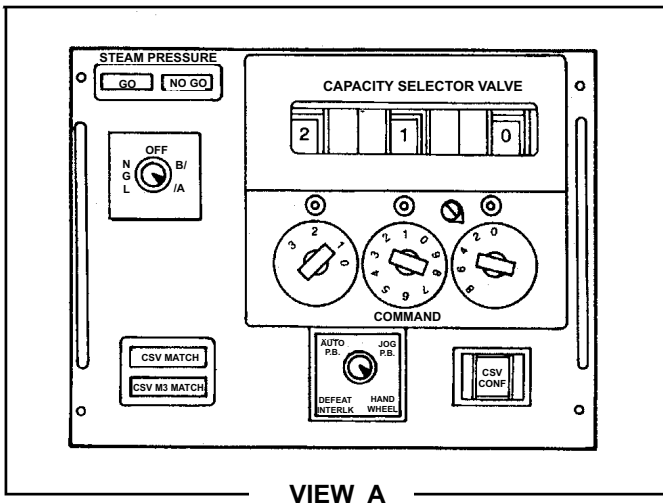
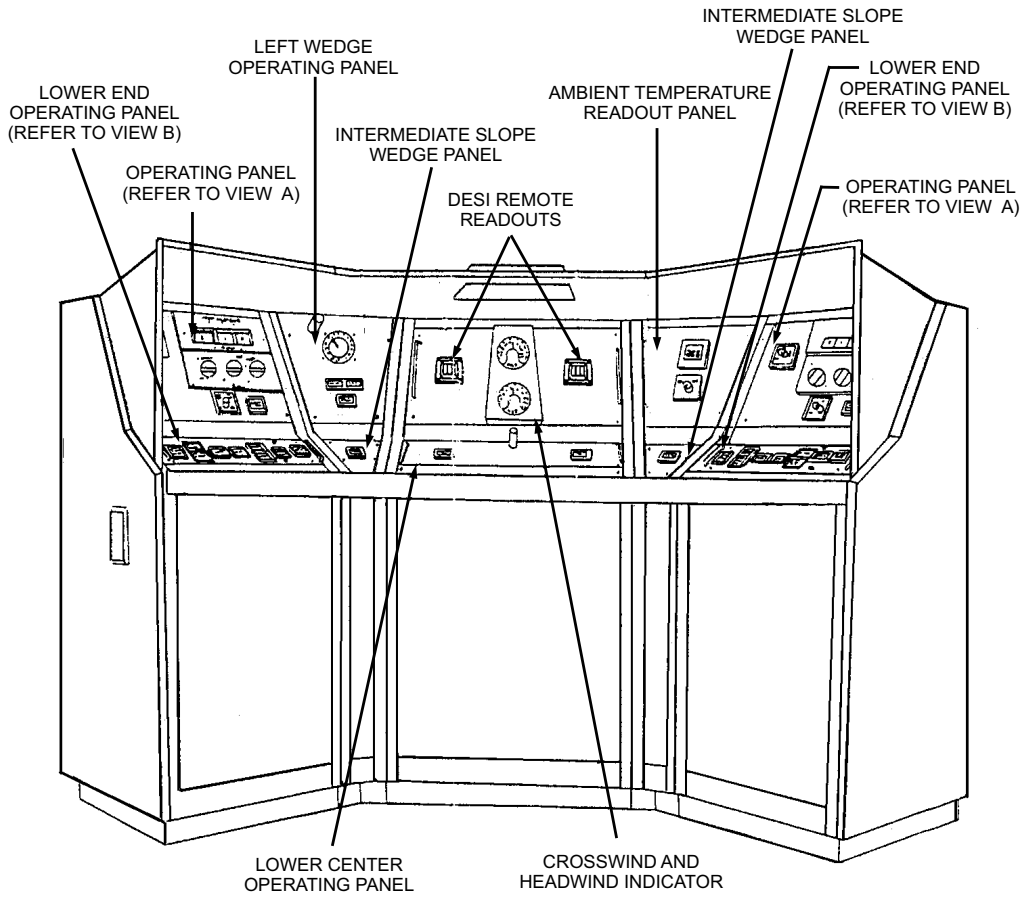
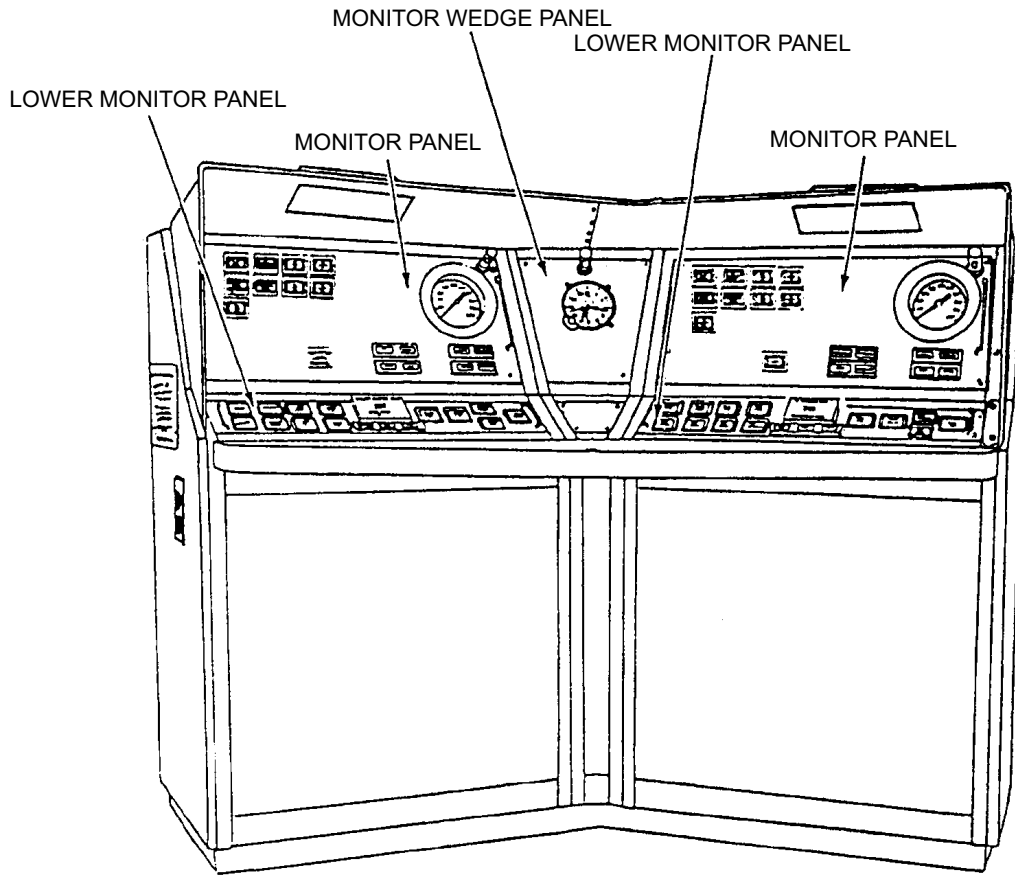

Figure 4-53.—Catapult-officer control console.

ABEF0454



ABEf0455

Figure 4-54.—Monitor control console.

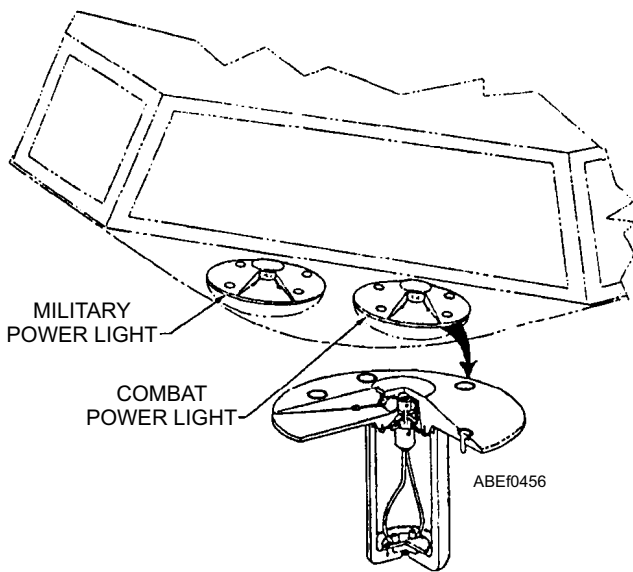

ABEf0456

Figure 4-55.—Military and combat power lights (typical).

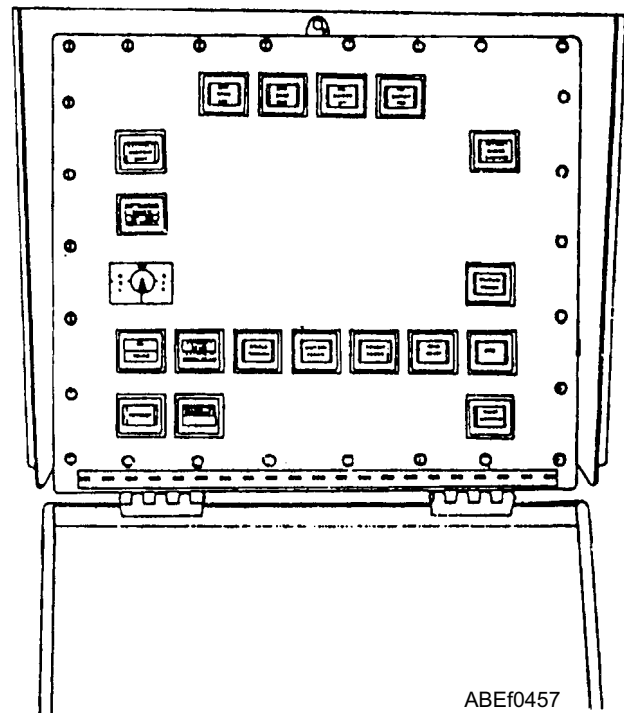

ABEf0457

Figure 4-56.—Deckedge control panel.

Monitor Control Console

The monitor control console (fig. 4-54) is used in conjunction with the catapult-officer control console and central charging panel during catapult operations. The control console is of wraparound design and is located facing forward in the ICCS. The console consists of a monitor panel and a lower monitor panel for each of the two adjacent catapults. The center section consists of a wedge panel containing a 24-hour clock. The switches and lights on the monitor panel and lower monitor panel enable the monitor control console operator to keep the launching officer advised of any malfunction occurring on that pair of catapults. During normal operation the green status lights are on. If a malfunction occurs, the green lights go out and the red lights come on. The malfunction lights will indicate red only when a malfunction occurs. A gauge on the monitor panel also indicates steam pressure. In addition to monitoring catapult status, the monitor operator retracts both shuttles and operates the NGL buffer during aircraft abort procedures.

Military Power Lights and Combat Power Lights

Military-power and combat-power lights (fig. 4-55) are located on the deck where they are visible to

the pilot when an aircraft is in launch position. The lights are used to signal the pilot when to apply full military power or combat power (afterburner) to aircraft engines during launching operations. These lights are used when operating in the normal (ICCS) mode.

Deckedge Control Panel

The deckedge control panel (fig. 4-56) is located on the bulkhead in the catwalk outboard of the associated catapult. The panel is located such that a clear and unimpeded view of the launching officer and hook up crew is assured. The deckedge control panel is used when launching operation are conducted in the deckedge mode with the launching officer directing operations from the center deck station.

Deckedge Signal Box

The deckedge signal box (fig. 4-57) is located at flight deck level adjacent to the deckedge control panel. Its function is to indicate the readiness of the catapult to the launching officer during operations. The deckedge signal box is only used when operating in the deckedge or central charging panel mode.

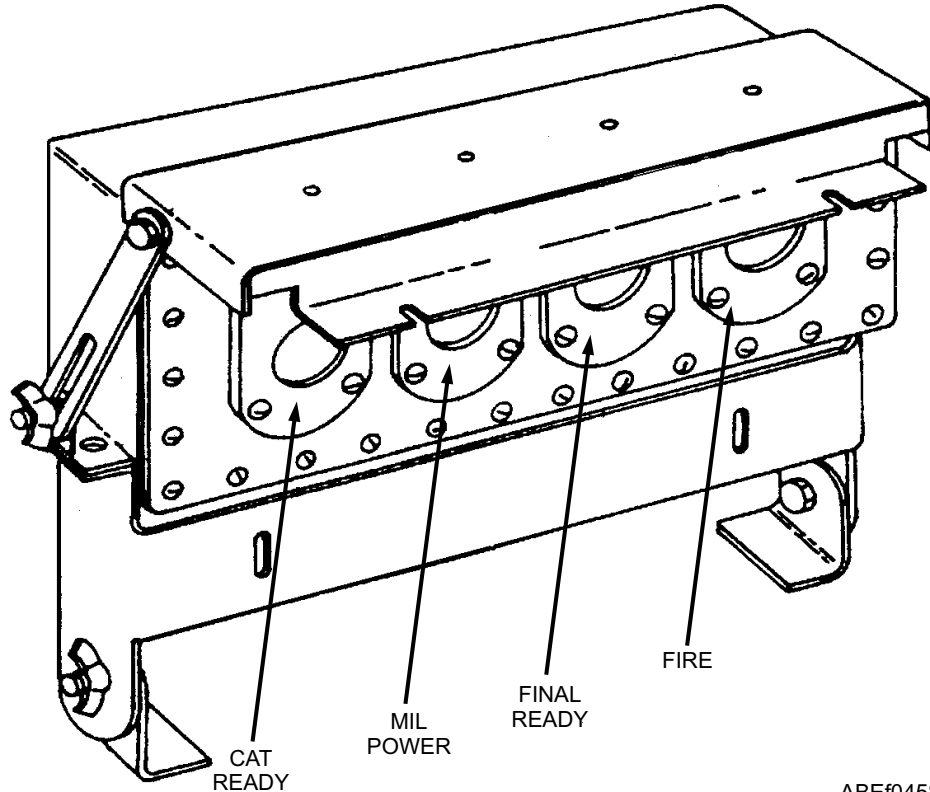

ABEf0458

Figure 4-57.—Deckedge signal box.

Deck Catapult-Suspend Light

The deck catapult-suspend light (fig. 4-58) is located on the edge of the flight deck outboard of its associated catapult and in clear view of all topside catapult crew members. The light flashes red during a suspend situation to indicate to personnel on the flight deck that a catapult-suspend situation exists.

Water Brake Control Panel

The water brake control panel (fig. 4-59) is located in the water brake pump room. In the event of an emergency or malfunction of the water brakes, a switch on the panel is used to suspend catapult operations and it further protection for personnel when access to the launching engine cylinders or water brake cylinder is required.

Central Charging Panel

The central charging panel (CCP) (fig. 4-60) provides a single, centralized station from which virtually all below decks catapult functions are accomplished. The CCP consists of left-front panel, left-intermediate-front panel, right-intermediate-front panel, right-front panel, transfer-switch enclosure, and launch-valve-emergency-cutout-valve, which are described in the following paragraphs. The deck-signal-light panel is located inside the central charging panel, below the left-intermediate front panel. Controls on the deck-signal-light panel are used to adjust the

intensity of the deck signal lights. The panel enclosure also contains pressure switches, gauge shutoff valves, and other piping components.

LEFT-FRONT PANEL.—The left-front panel contains the switches and pressure gauges for the operation and monitoring of the catapult hydraulic system. The panel contains pressure gauges and OFF-ON switches for the main hydraulic pumps, the booster pump, the circulating pump, and the lubrication pump. Also included are a gravity-tank fluid temperature gauge, three main hydraulic accumulator hydraulic-pressure gauges, an off-on pump delivery control switch, a primary pump selector switch, a retraction-engine suspend switch, a blowdown valve for the retraction-engine hydraulic fluid, and delivery control fuses.

LEFT-INTERMEDIATE-FRONT PANEL.—The left-intermediate-front-panel contains the valves and pressure gauges for charging or blowing down catapult components that require air pressure for their operation. Gauges on the panel indicate the air pressure in the air side of the main hydraulic accumulator, the air flask, the air side of the cable-tensioner accumulator, the low-pressure-air supply, medium-pressure-air supply, and the air side of the tensioner surge accumulator. A dual gauge indicates the air pressure at

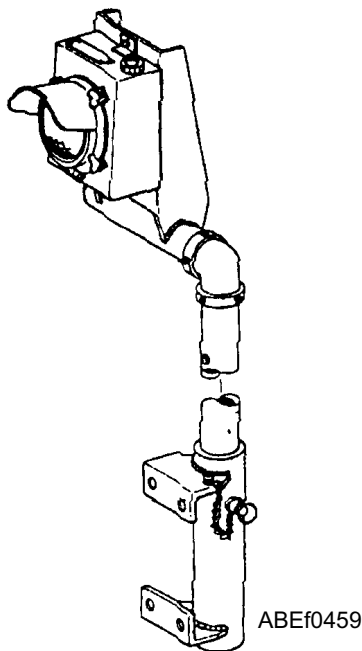

Figure 4-58.—Deck catapult-suspend light.

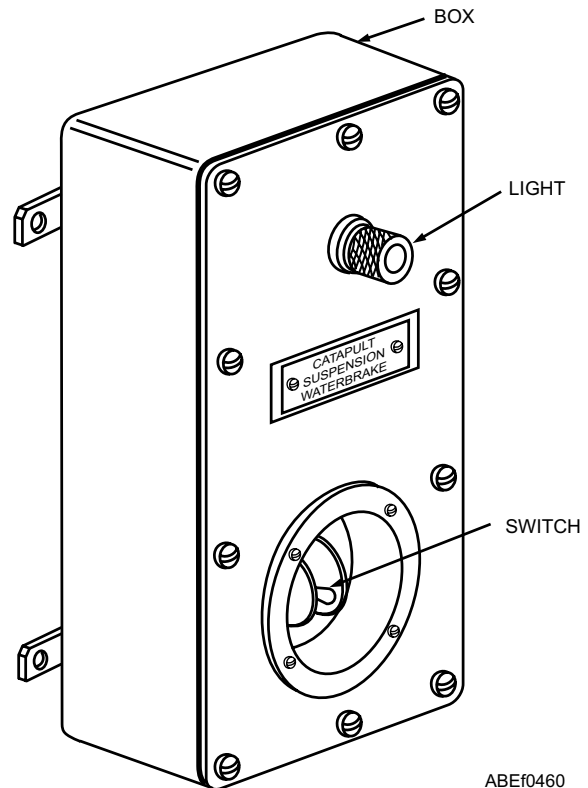

Figure 4-59.—Water brake control panel.

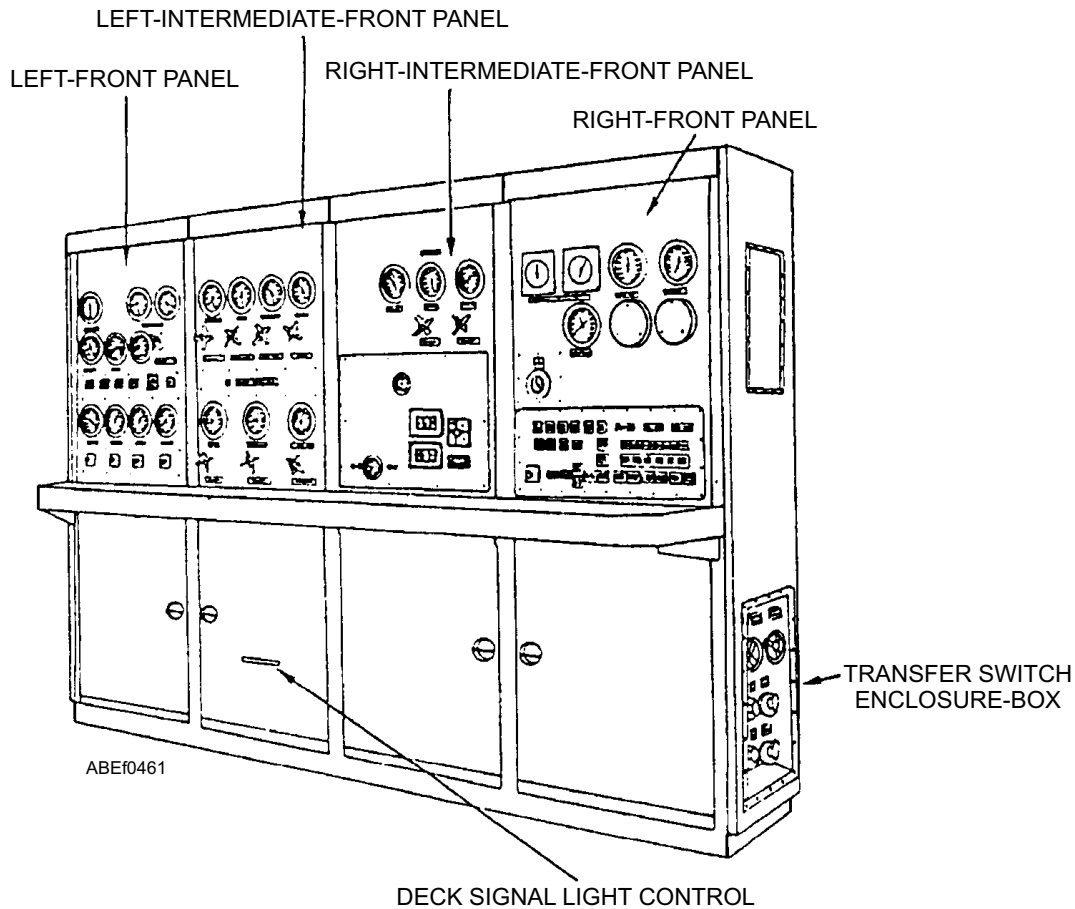

Figure 4-60.—Central charging panel.

the dome of the tensioner regulator and the pressure in the hydraulic fluid side of the tensioner surge accumulator. Valves on the panel are used for charging and blowing down the air flask, the air side of the main hydraulic accumulator, the air side of the cable-tensioner accumulator, the dome of the tensioner regulator, and the air side of the tensioner surge accumulator. There is also a valve to shut off the low-pressure-air supply. A bank of red and green indicator lights on the panel indicates go and no-go indication for various catapult functions.

RIGHT-INTERMEDIATE-FRONT PANEL.—

The top portion of the right-intermediate-front panel contains the pressure gauges and valves monitoring, charging, and blowing down the nose gear launch accumulators. The lower portion of the panel contains a 24-hour clock and the CSV setting controls.

RIGHT-FRONT PANEL.—The right-front panel top portion contains the launch valve timer readout, water brake elbow pressure gauges, the wet accumulator pressure gauge, the main power (RC) on/off switch and a panel with the steam fill/blowdown valve selectors. The lower portion of this panel contains lights and switches for operating and monitoring

catapult and wet steam accumulator components. The lowest row of lights and switches provide emergency operational capability at the charging panel.

Transfer Switch Enclosure

The transfer switch enclosure is located on the lower right end of the central charging panel. The switch enclosure contains switches that provides a means of transferring catapult control functions for operating in either the deckedge or central charging panel emergency mode. The other switches provide a means of transferring pri-fly, deck signal lights, central control station, and the catapult interlock switch out of the catapult control circuit.

Launch Valve Emergency Cutout Valve

The launch valve emergency cutout valve is located on the lower left end of the central charging panel. The emergency cutout valve provides the central charging panel operator with a positive control to prevent the launch valve from opening during a HANGFIRE condition. When placed in the emergency position, the cutout valve electrically and hydraulically shifts the launch valve control system to the closed position.

Central Junction Box

The central junction box (fig. 4-61) provides a single location for the catapult control system wiring and relays. The terminal board and all wires are clearly marked for easy identification. Relay status lights and a relay tester aid in troubleshooting electrical malfunctions.

CATAPULT CONTROL SYSTEM FOR CV-63, CVN-65, and CV-67

The control system consists of those panels, lights, and switches that are used to operate a catapult

throughout the various operational phases. The following is a description of the control system components.

Deckedge Control Panel

The deckedge control panel (figs. 4-62 and 4-63) is located on the bulkhead in the catwalk outboard of the associated catapult. The panel is located such that a clear and unimpeded view of the launching officer and hook up crew is assured. The deckedge control panel contains lights and switches used for catapult control during launching, retraction, and bridle tensioning phases.

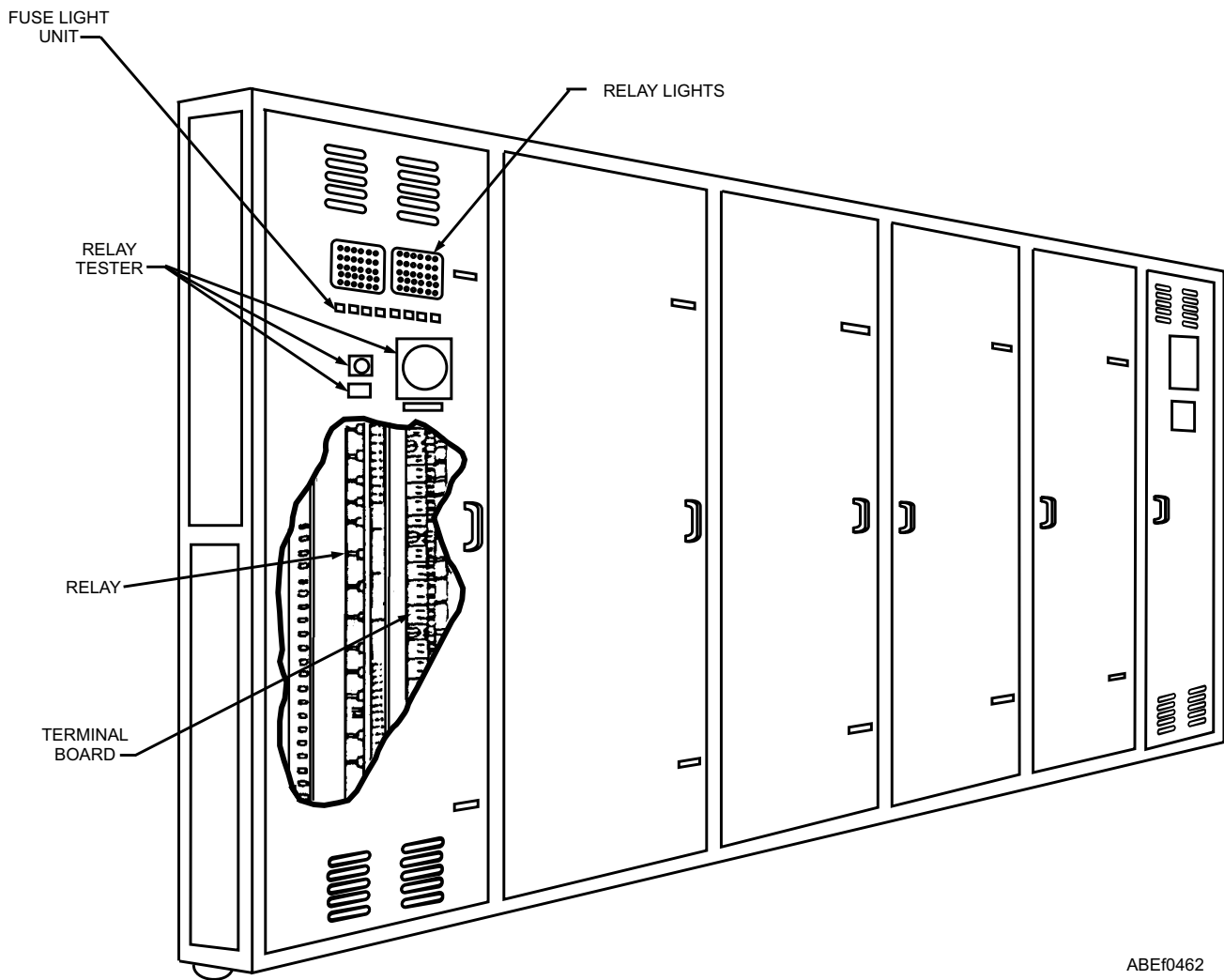

ABEf0462

Figure 4-61.—Central junction box.

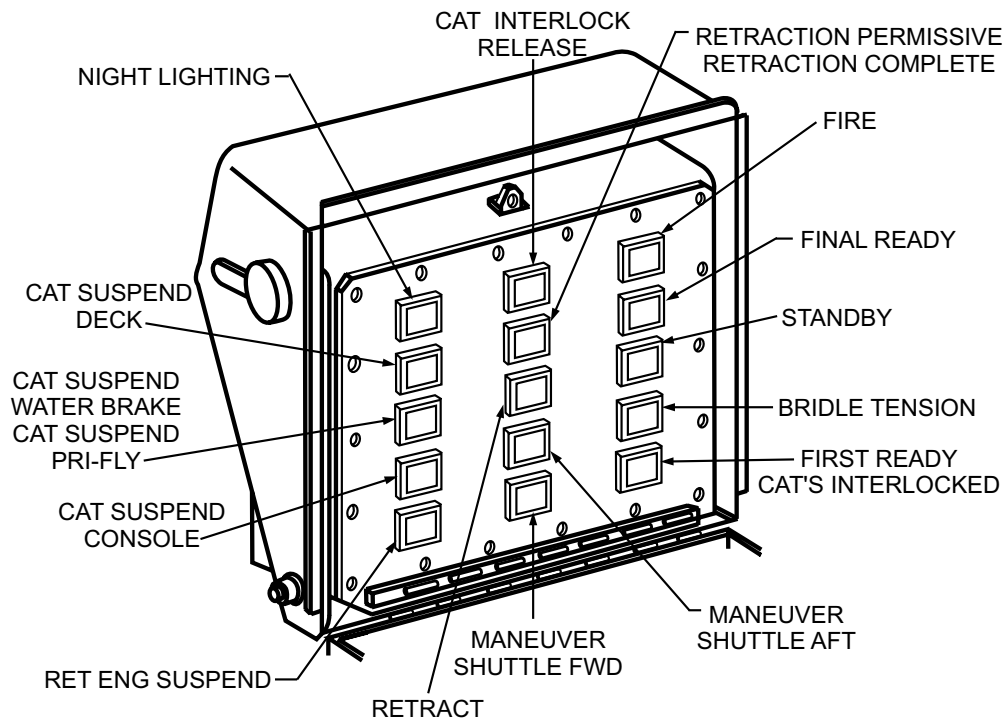

ABEf0463

Figure 4-62.—Deckedge control panel (CVN-65 and CV-67).

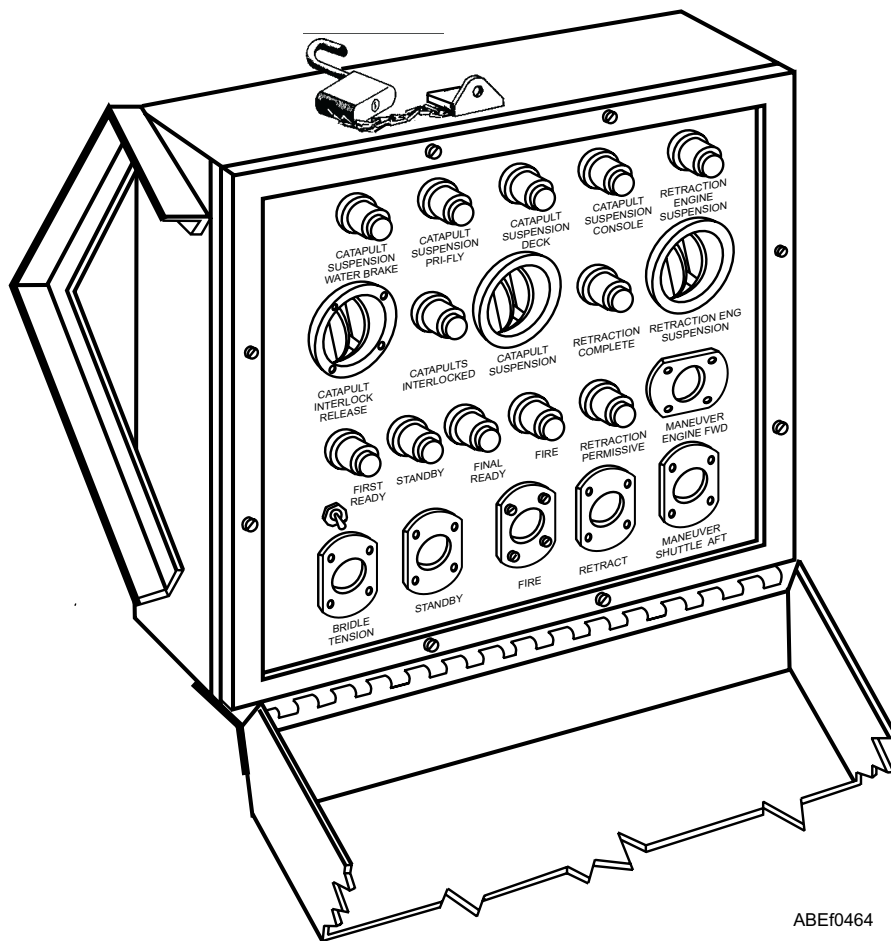

ABEf0464

Figure 4-63.—Deckedge control panel (CV-63).

Main Control Console (CVN-65 and CV-67)

The main control console (fig. 4-64) is used in conjunction with the deckedge control panel during catapult operation. The control console consists of a monitor panel, operating panel, steam panel, the launch valve cutout valve, and the transfer switch enclosure.

MONITOR PANEL.—The monitor panel consists of a series of status lights on the top right side for various catapult system pressures. These lights will indicate green for pressure within safe operating limits or red for out-of-limit pressures. Malfunction lights are located down the right side of the panel. These lights will indicate red in the event of a malfunction. The switches that energize these lights will also interrupt the launching sequence. The monitor panel also contains the launch valve stroke timers, and the digital endspeed indicator.

OPERATING PANEL.—The operating panel is used in conjunction with the deckedge panel during launching operations. It contains the lights, push buttons, and switches that are used for catapult control during launching, retraction, and bridle tensioning phases. The operating panel also contains the CSV setting controls.

STEAM CHARGING PANEL.—The steam charging panel contains steam pressure and temperature gauges, status lights, and setting controls. The setting controls provide a means of operating the fill valves automatically or by a manually set air signal. In normal operations, the fill valves are operated in automatic charge. With automatic charge and charge valve selected, the air signal to the fill valves is preset to closely control the opening rates of the fill valves. The manually loading air regulator is used to control the air signal to the blowdown valve and to the fill valves when in manual charge.

Transfer Switch Enclosure

The transfer switch enclosure is located on the lower right side of the main control console. The transfer switch enclosure provides a means of isolating remote panels and switching control to the control console. The transfer switches are rotated from NORMAL to EMERGENCY, as required, to isolate a remote panel that has malfunctioned.

Launch Valve Emergency Cutout Valve

The launch valve emergency cutout valve is located on the lower left side of the main control console. The

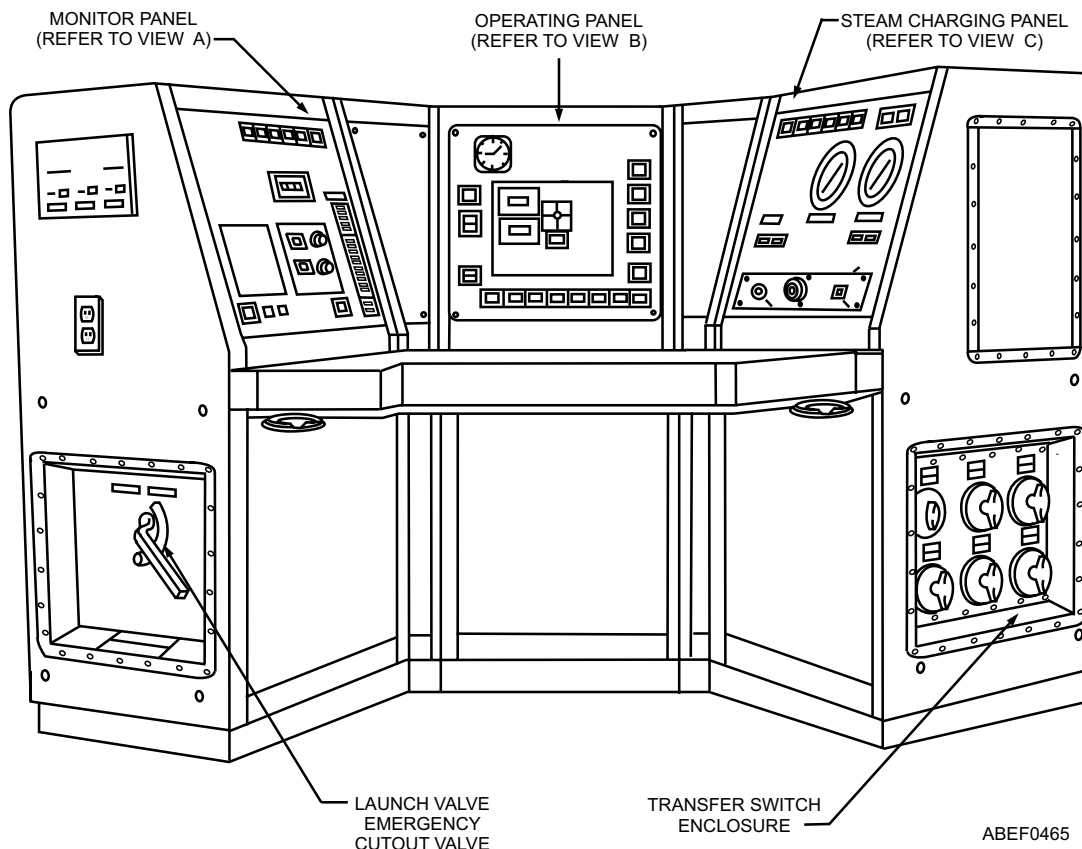

Figure 4-64.—Main control console (CVN-65 and CV-67).

emergency cutout valve provides the console operator a positive control to prevent the launch valve from opening during a HANGFIRE condition. When placed in the emergency position, the cutout valve electrically and hydraulically shifts the launch valve control system to the closed position.

Central Junction Box

The central junction provides a single location for the catapult control system wiring and relays. The terminal board and all wires are clearly marked for easy identification. Relay status lights and a relay tester aid in troubleshooting electrical malfunctions.

Deckedge Signal Box

The deckedge signal box (fig. 4-65) is located at flight deck level adjacent to the deckedge control panel. Its function is to indicate the readiness of the catapult to the launching officer during operations.

Water Brake Control Panel

The water brake control panel (see fig. 4-59) is located in the water brake pump room. In the event of an emergency or malfunction of the water brakes, a switch on the panel is used to suspend catapult operations and it is further protection for personnel when access to the launching engine cylinders or water brake cylinder is required.

Main Control Console (CV-63)

The main control console (fig. 4-66) is used in conjunction with the deckedge control panel during catapult operation. The control console consists of an operating panel, an emergency panel, a malfunction panel, two gauge panels, a launch valve cutout valve, and the transfer switch enclosure.

OPERATING PANEL.—The operating panel is used in conjunction with the deckedge panel during launching operations. It contains the lights, push buttons, and switches that are used for catapult control during the launching sequence.

EMERGENCY PANEL.—The emergency panel contains all the lights, push buttons, and switches are required to provide complete control during the launching, retraction, and bridle tensioning phases.

STEAM GAUGE PANEL.—The steam gauge panel contains a steam pressure gauge, CSV setting controls, digital endspeed indicator and launch valve timer displays.

GAUGE PANEL.—The gauge panel provides a means of monitoring steam and hydraulic temperature and pressures.

MALFUNCTION PANEL.—The malfunction panel contains lights that indicate the status of certain catapult components or systems. The hydraulic pressure and the valve position malfunction lights are

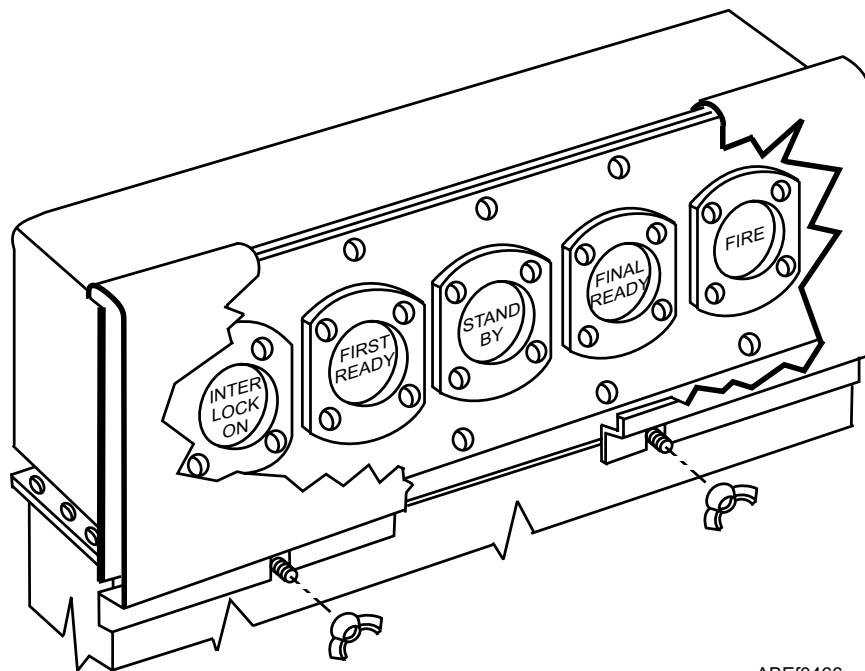

ABEf0466

Figure 4-65.—Deckedge signal box.

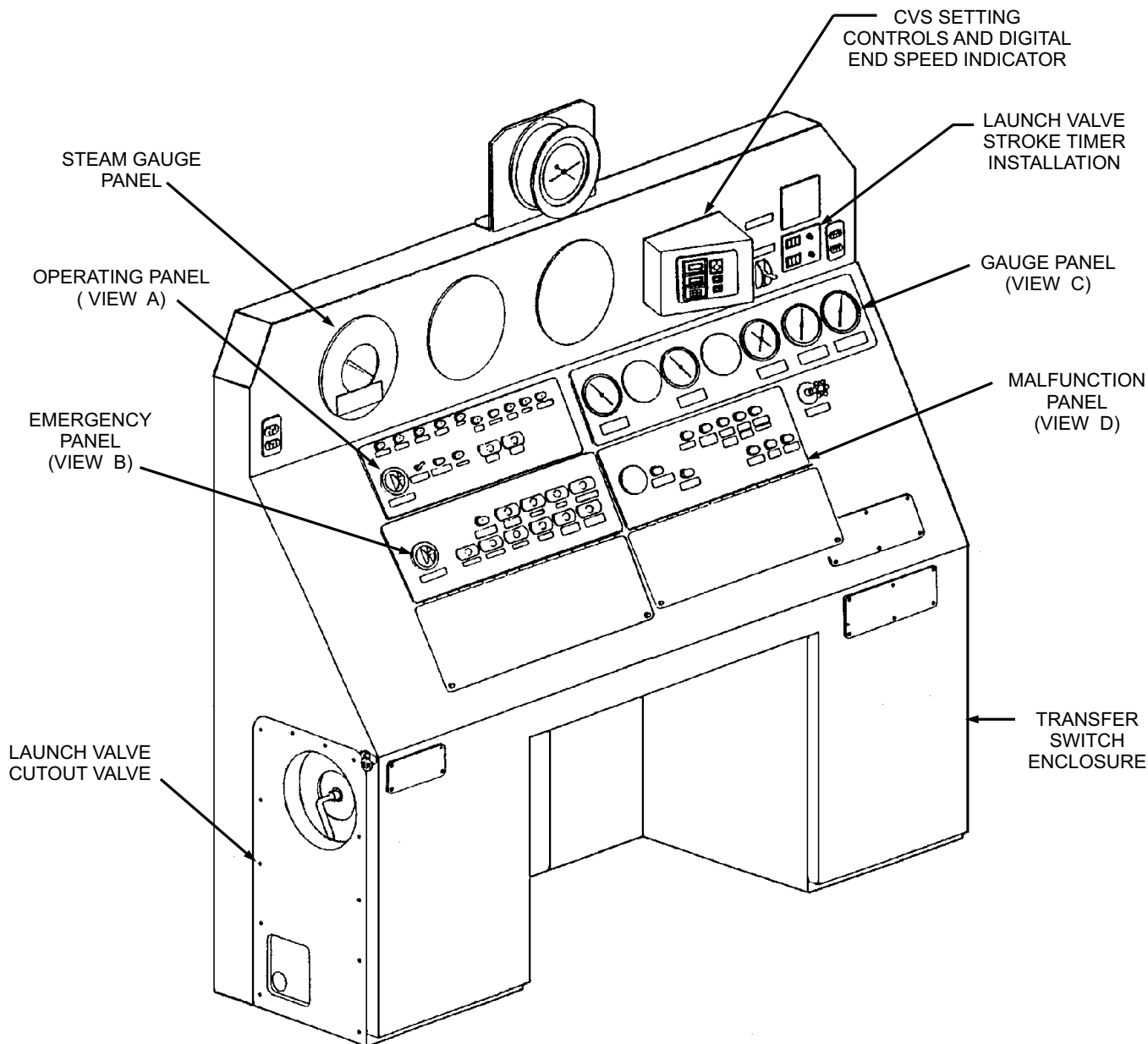

ABEf0467

Figure 4-66.—Main control console (CV-63).

red and will illuminate in the event of a malfunction. The blow through no-load light is amber and will illuminate when the blow through circuit is energized. All other lights on this panel are green and will fail to illuminate in the event of a malfunction.

Transfer Switch Enclosure

The transfer switch enclosure is located on the lower right side of the main control console. The transfer switch enclosure provides a means of isolating remote panels and switching control to the control console. The transfer switches are rotated from

NORMAL to EMERGENCY, as required, to isolate a remote panel that has malfunctioned.

Launch Valve Emergency Cutout Valve

The launch valve emergency cutout valve is located on the lower left side of the main control console. The emergency cutout valve provides the console operator a positive control to prevent the launch valve from opening during a HANGFIRE condition. When placed in the emergency position, the cutout valve electrically and hydraulically shifts the launch valve control system to the closed position.

Central Charging Panel

The central charging panel (fig. 4-67) provides a single centralized station from which pneumatic and hydraulic systems are controlled and monitored.

LEFT-FRONT PANEL.—The left-front panel contains the switches and pressure gauges for the operation and monitoring of the catapult hydraulic system. The panel contains pressure gauges and OFF-ON switches for the main hydraulic pumps, the booster pump, the circulating pump, and the lubrication pump. Also included are a gravity-tank fluid temperature gauge, three main hydraulic accumulator hydraulic-pressure gauges, an off-on pump delivery control switch, a primary pump selector switch, a retraction-engine suspend switch, a blowdown valve for the retraction-engine hydraulic fluid, and delivery control fuses.

LEFT-INTERMEDIATE-FRONT PANEL.—The left-intermediate-front-panel contains the valves and pressure gauges for charging or blowing down catapult components that require air pressure for their operation. Gauges on the panel indicate the air pressure in the air side of the main hydraulic accumulator, the air flask, the air side of the cable-tensioner accumulator, the low-pressure-air supply, medium-pressure-air supply, and the air side of the tensioner surge

accumulator. A dual gauge indicates the air pressure at the dome of the tensioner regulator and the pressure in the hydraulic fluid side of the tensioner surge accumulator. Valves on the panel are used for charging and blowing down the air flask, the air side of the main hydraulic accumulator, the air side of the cable-tensioner accumulator, the dome of the tensioner regulator, and the air side of the tensioner surge accumulator. There is also a valve to shut off the low-pressure-air supply. A bank of red and green indicator lights on the panel indicates go and no-go indication for various catapult functions.

RIGHT-INTERMEDIATE-FRONT PANEL.—The top portion of the right-intermediate-front panel contains the pressure gauges and valves monitoring, charging, and blowing down the nose gear launch accumulators. The right-intermediate-front panel is installed on CVN-65 only.

REVIEW QUESTIONS

- Q1. *How are the launching engine cylinders heated?*
- Q2. *How is the catapult trough steam smothering actuated?*
- Q3. *What is the purpose of the launch valve steam valve?*

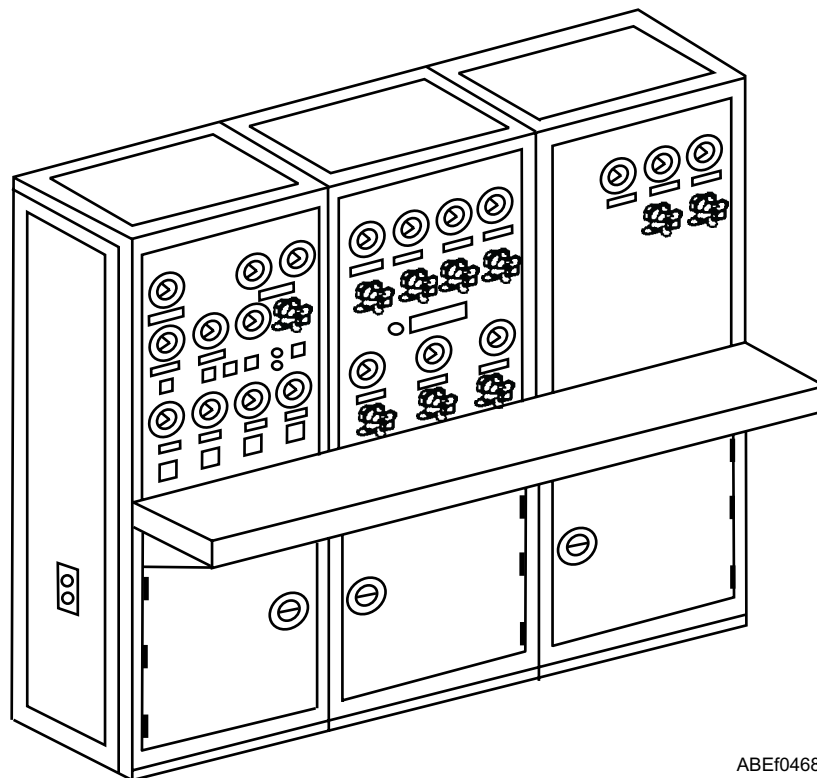

ABEf0468

Figure 4-67.—Central charging panel.

- Q4. What provides a means of measuring launch valve performance?
- Q5. What is the purpose of the keeper valve?
- Q6. What component transfers the forward motion of the pistons to the aircraft?
- Q7. What system provides a means of lubricating the launching engine cylinders?
- Q8. The bridle tensioning system full-aft limit switch is part of what catapult circuit?
- Q9. The auxiliary tank of the hydraulic system has a capacity of how many gallons?
- Q10. What is the function of the retraction engine and drive system?
- Q11. The controls for the ICCS are divided between what panels?
- Q12. During operation, what indicates the readiness of the catapult to the launching officer?

OPERATIONS

LEARNING OBJECTIVE: Describe the operation of a steam catapult.

A steam fill-valve system controls the amount of steam from the ship's boilers to the wet-steam accumulator. Steam from the steam accumulator is then released into the launching engine cylinders through the launch valve (the amount of steam used is varied by a capacity selector valve [CSV] assembly that controls the launch valve opening rate).

This surge of steam acts on a set of steam pistons inside the launching engine cylinders. These pistons are connected to a shuttle that is attached to an aircraft. The force of the steam being released from the steam accumulator pushes the pistons forward, towing the shuttle and aircraft at an increasing speed until aircraft take-off is accomplished.

The shuttle and steam pistons are stopped at the end of their "power stroke" as a tapered spear (fig. 4-68) enters a set of water-filled cylinders, forcing the water to be "metered" out of the cylinders as the tapered spear moves into them.

After the shuttle and pistons have been stopped, a grab is advanced forward along the catapult trough covers by means of the retraction engine, and attaches to the shuttle assembly. The retraction engine is then reversed and returns the grab, shuttle, and piston

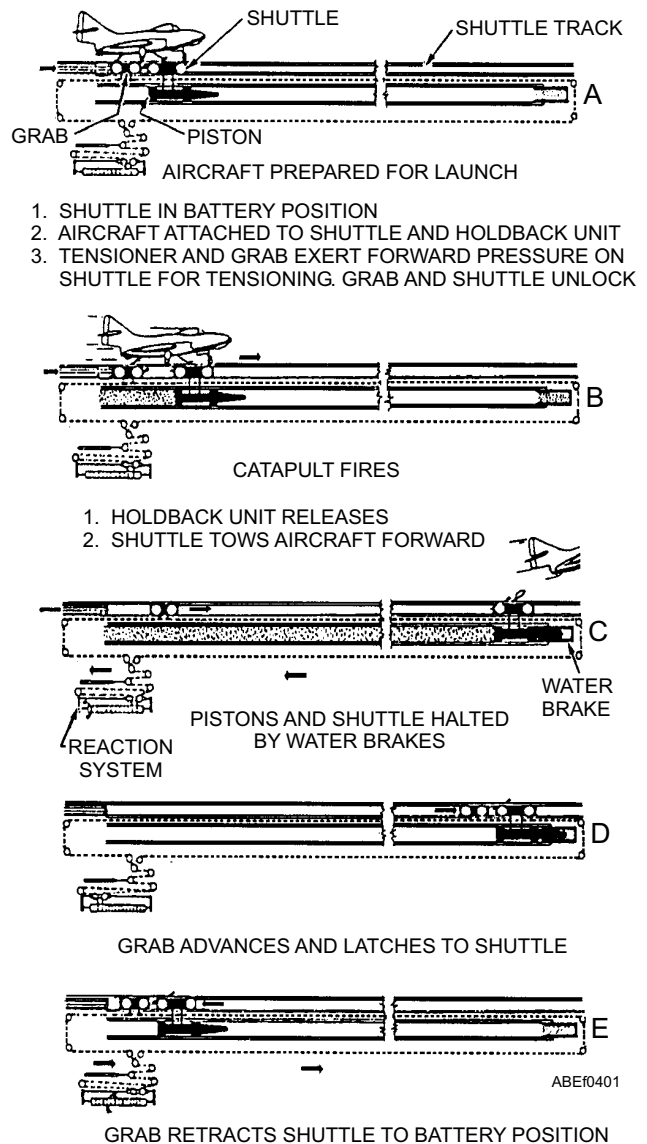

Figure 4-68.—Catapult operation.

assembly to the battery position in preparation for the next aircraft launch.

A integrated catapult control station (ICCS), central charging panel (CCP), main control console, deckedge control panel, retraction engine control/charging panel, and water brake panel are used in conjunction to direct and integrate the catapult electrical and hydraulic systems functions and to control the sequence of operations through a normal catapult launching cycle.

Preliminary functional tests are performed by all operating personnel. These tests consist of at least two no-load launchings, during which the control system is operated through its complete cycle. The functioning of as many component parts of the catapult as possible should be observed by personnel at the various stations

during the preliminary functional tests. All malfunctions must be reported to the maintenance officer, catapult officer, or catapult captain.

INTEGRATED CATAPULT CONTROL STATION (ICCS) NO-LOAD LAUNCHING PROCEDURES

No-load launches are conducted during the accomplishment of the preoperational MRCs. No-load launches may also be required for post maintenance catapult checkout.

WARNING

NO-load tests shall be conducted under the supervision of a qualified launching officer. To prevent injury to personnel, safety lines shall be rigged along the deck inboard of the catapult and safety personnel shall be stationed in the catwalk to keep unauthorized personnel clear of the catapult area.

Perform the following steps for no-load test launchings:

1. With the catapult track clear, the safety observer signals the monitor operator to retract.
2. With the grab and shuttle in battery position, the safety observer signals the monitor to maneuver forward a sufficient distance to allow grab/shuttle separation (one to two feet is adequate).
3. With a crewmember manually releasing the grab latch, the safety observer signals the monitor operator to maneuver the grab to the fully aft position.
4. The charging panel operator closes the fluid supply valve to the bridle tensioner pressure regulator and blows off the air pressure in the dome of the bridle tensioner regulator, surge accumulator, and from the dome of the internal tensioning pressure regulator.
5. The launching officer shall set the CSV command setting to the required value and ensure that the CSV is confirmed and that the CSV match lights come on.
6. The charging panel operator shall ensure that the CSV command setting is in the no-load range, and if in agreement with the command setting, depresses the set pushbutton, and ensures that command, position, and

mechanical counter all match. If in disagreement with the command setting, the charging panel operator shall not depress the set pushbutton until the setting discrepancy is resolved.

7. The launching officer notifies pri-fly to make a 5MC warning announcement of the impending no load launches.
8. The launching officer depresses the bridle tensioning pushbutton, military power, and final ready pushbuttons.
9. The safety observer shall ensure that the catapult track is clear and all safety personnel are indicating thumbs up and signal the launching officer to fire the catapult.
10. The launching officer shall check for a clear launching area and depress the fire pushbutton.
11. Repeat the above procedures if necessary for subsequent no loads.

INTEGRATED CATAPULT CONTROL STATION (ICCS) LAUNCHING PROCEDURES

Where the ICCS is the primary mode of controlling fixed-wing-aircraft launching operations, the following procedures apply:

As the ship approaches the launch course, the air officer monitors the wind repeater and keeps the launching officer(s) advised of the relative wind velocity. When permission to launch aircraft is received from the bridge, a final check must be made to ensure relative wind is within the limits prescribed in the applicable launching bulletin. This is accomplished before changing the rotating beacon(s) from red to green, which lights the pri-fly "go light" on the catapult officers ICCS console, thereby clearing the launching officer(s) to begin launching.

The following steps must be completed before the launching officer assumes control of the aircraft.

1. Before aircraft tension, the topside safety petty officer performs the following:
 - 1) Ensures that appropriate jet blast deflectors are raised.
 - 2) Supervises the attachment of the holdback to aircraft.
 - 3) Checks the catapult area forward.
 - 4) Gives the tension signal to the director.

2. The catapult director performs the following:
 - 1) Checks the catapult area forward.
 - 2) Ensures that the appropriate jet blast deflectors are raised and that all personnel are clear of the jet blast and prop wash.
 - 3) Signals the launching officer in the ICCS to take tension, while signaling the pilot to release brakes; the pilot in turn applies power as specified in the *NATOPS Manual* for that type of aircraft.
 - 4) After the aircraft is tensioned on the catapult, signals the pilot, if required, to raise the aircraft launch bar.
 - 5) Turns the aircraft over to the ICCS deck signal lights.
3. After tension is taken, the top side safety petty officer performs the following:
 - 1) Inspects for proper aircraft hookup and alignment.
 - 2) Ensures that all personnel are clear of the aircraft on the catapult.
 - 3) Inspects the launch bar to ensure proper engagement with the catapult shuttle after full power application and catapult tensioning are completed.
 - 4) Signals "thumbs up" to the catapult safety observer with a hand or wand signal if all conditions are satisfactory for launch.
4. The squadron aircraft inspector performs the following:
 - 1) Makes a final inspection of the aircraft for proper configuration; flaps; trim settings; leaks; and loose panels, doors, or hatches.
 - 2) Signals "thumbs up" to the catapult safety observer with a hand or wand signal if all conditions are satisfactory for launch.
5. The catapult safety observer then signals "suspend" to the launching officer in the ICCS.
5. The catapult safety observer performs the following:
 - 1) Visually checks for proper aircraft hookup and alignment.
 - 2) Ensures that the appropriate jet blast deflectors are raised and that all personnel are clear of the aircraft, jet blast, and prop wash.
6. The launching officer signals for final turnups by lighting the military power (green) light and the combat power (amber) light, if applicable, in that order. The pilot shall apply full power and afterburner, if applicable, as these lights are illuminated. When the pilot is ready for launch, he or she signifies by saluting the catapult safety observer or, at night, by turning the navigation lights on steady. The pilot ensures that no exterior lights are on before the military power/combustion power (afterburner launch) lights are illuminated.
7. The catapult safety observer, after observing the pilot's ready to launch signal performs the following:
 - 1) Makes a final scan of the aircraft.
 - 2) Checks for a "thumbs up" signal from the catapult topside safety petty officer and the squadron's aircraft inspector.
 - 3) Signals "thumbs up" to the launching officer in the ICCS with a hand or green wand signal if all conditions are satisfactory for the launch.
8. Upon receiving the catapult safety observer's "thumbs up" signal and before firing the catapult, the launching officer performs the following:
 - 1) Checks for a pri-fly go light on his or her console.
 - 2) Scans the normal area of visibility.
 - 3) Checks the catapult officer console for satisfactory catapult launch condition.
 - 4) Checks deck and traffic forward.
 - 5) Checks deck pitch.
 - 6) Ensures the catapult safety observer is giving the "thumbs up" signal.

CAUTION

If there is any doubt in the mind of the topside safety petty officer, director, or squadron aircraft inspector as to satisfactory hookup or aircraft configuration, he or she must so indicate to the catapult safety observer by initiating a crossed arm suspend signal (day) or a horizontal wand movement (night). The

9. After ensuring that all conditions are satisfactory, the launching officer depresses the fire button. If, after coming to full power on the catapult, the pilot desires to stop the launch, he or she does so by shaking the head negatively, rather than by giving the "thumbs down" signal. At the same time, the pilot transmits "suspend, suspend." At night, the visual signal also consists of not turning on the navigation lights. The catapult safety observer signals suspend to the launching officer in the ICCS, using standard hand or wand signals.

NON-INTEGRATED CATAPULT CONTROL STATION (ICCS) NO-LOAD LAUNCHING PROCEDURES

No-load launches are conducted during the accomplishment of the preoperational MRCs. No-Loads launches may also be required for post maintenance catapult checkout.

WARNING

NO-Loads tests shall be conducted under the supervision of a qualified launching officer. To prevent injury to personnel, safety lines shall be rigged along the deck inboard of the catapult and safety personnel shall be stationed in the catwalk to keep unauthorized personnel clear of the catapult area.

Perform the following steps for no-load test launchings:

1. With the catapult track clear, the launching officer signals the deckedge operator to retract.
2. With the grab and shuttle in battery position, the topside safety petty officer signals the deckedge operator to maneuver forward a sufficient distance to allow grab/shuttle separation (one to two feet is adequate).
3. With a crewmember manually releasing the grab latch, the topside petty officer signals the deck edge operator to maneuver the grab to the fully aft position.
4. The retraction engine operator closes the fluid supply valves to the bridle tensioner pressure regulator and the internal tensioning pressure regulator.
5. The launching officer shall set the CSV command setting to the no load value.

WARNING

The main control console operator shall not place the catapult in first ready until the CSV setting has been made, verified and the catapult is ready for no load launches.

6. The console operator shall ensure that the CSV command setting is in the no-load range and depress the set pushbutton. The console operator then ensures that command, position, and mechanical counter all matches and places the catapult in first ready. If in disagreement with the command setting, the console operator shall not depress the set pushbutton and shall leave the catapult in safe until the setting discrepancy is resolved.
7. The launching officer shall ensure that the CSV has been properly set by ensuring a green CSV status light.
8. The launching officer notifies pri-fly to make a 5MC warning announcement of the impending no load launches.
9. The launching officer checks that safety lines are properly rigged and safety personnel are on station. The launching officer then signals the deckedge operator to place the catapult in final ready.
10. The deckedge operator presses the bridle tensioning and standby pushbuttons.
11. The console operator observes the standby light come on, ensures that all conditions are satisfactory and depresses the final ready pushbutton.
12. The deckedge operator observes the final ready light come on and gives the final ready signal.
13. The launching officer shall check for a clear launching area and give the fire signal.
14. The deckedge operator first looks forward and aft to ensure a clear launch area and then presses the fire pushbutton.
15. Repeat the above procedures if necessary for subsequent no loads.

NON-INTEGRATED CATAPULT CONTROL STATION (ICCS) LAUNCHING PROCEDURES

The following steps must be completed before the launching officer assumes control of the aircraft.

1. Before aircraft tension, the topside safety petty officer performs the following:
 - 1) Ensures that appropriate jet blast deflectors are raised.
 - 2) Checks the catapult area forward.
 - 3) Supervises the attachment of the holdback to aircraft.
 - 4) Gives the tension signal to the director.
2. The catapult director performs the following:
 - 1) Checks the catapult area forward.
 - 2) Ensures that the appropriate jet blast deflectors are raised and that all personnel are clear of the jet blast and prop wash.
 - 3) Signals the deckedge operator to take tension, while signaling the pilot to **RELEASE BRAKES**; the pilot in turn applies power as specified in the *NATOPS Manual* for that type of aircraft.
3. When the catapult director gives the hand signal that tension is to be taken, the deckedge operator immediately presses the **BRIDLE TENSION** button and verbally relays the message to the console operator via the sound-powered phone by saying the words **TAKING TENSION**. Under normal conditions this is the last word spoken until the launch is complete. This is to prevent misunderstanding; for example, misfire, hangfire, fire.
4. Only after correct bridle tension has been applied is control of the aircraft passed, as follows: The director, upon completing bridle tension, immediately passes control of the aircraft by pointing both hands toward the catapult officer.
 5. The catapult officer verifies steam pressure readings on the gauges at the center deck panel. The catapult officer observes the first ready signal from the deckedge operator, and acknowledges the signal by holding two fingers overhead, hesitates, and then rotates the hand rapidly for full engine turnup of the aircraft.
 6. When the catapult officer starts giving the full power turnup (two-finger) signal, the launching operation proceeds.
 7. The deckedge operator, observing the catapult officer's full power turnup signal, immediately presses the standby button. As soon as the standby (green) light comes on at the deckedge panel, he or she holds two fingers overhead. The console operator, observing that the standby (green) light is on at his or her console, immediately checks all gauges and lights. If everything is ok, he or she puts the catapult into final ready condition.
 8. When the final ready condition is reached, all final ready (red) lights come on, and the launching operation continues. As soon as the final ready (red) light comes on at the deckedge panel, the deckedge operator immediately holds both hands open above his or her head.
 9. With the aircraft at full power, the pilot checks all instruments and gauges. If everything is ok, he or she gets set and indicates ready by turning his or her head slightly toward the catapult officer, executes a right- or left-hand salute, and then positions his or her head against the cockpit headrest. The pilot may refuse to be launched by shaking his or her head negatively, in which case the catapult officer gives the suspension signal.)
 10. The launch signal is given only after the catapult has reached final ready and the pilot of the aircraft indicates he or she is ready. The catapult officer ensures that the pilot's head is back against the headrest, checks that the deck is clear forward, and then executes the fire signal. Upon receiving the fire signal, the deckedge operator makes a final check of the flight deck and catwalks. If they are clear, he or she depresses the fire push button.

NOTE

Aircraft to be launched receive a preliminary engine check before being spotted on the catapult; therefore, normal operational procedure is for the catapult officer to go directly into the full power turnup signal after the aircraft has been tensioned.

5. The catapult officer verifies steam pressure readings on the gauges at the center deck panel. The catapult officer observes the first ready signal from the deckedge operator, and acknowledges the signal by holding two fingers overhead, hesitates, and then rotates the

CAUTION

The deckedge operator must not anticipate the fire signal; if any discrepancy in aircraft hookup is noted or if the deck and catwalks are not clear, he or she must **NOT** fire but must suspend and notify the catapult officer of the discrepancy.

INTEGRATED CATAPULT CONTROL STATION (ICCS) SUSPEND PROCEDURES

A catapult launch can be halted at any time up until the fire pushbutton has been depressed by actuating a catapult suspend switch. Suspend switches are located at pri-fly, launching officer's console, monitor console, central charging panel, and at the water brake station.

NOTE

If the suspend switch at the water brake station is actuated during catapult operations, breaking tension by energizing maneuver aft cannot occur. If this switch initiated a suspend action, the charging panel operator shall actuate suspend and direct the water brake station to release the water brake suspend.

Actuation of any catapult suspend switch lights a red flashing light mounted at the edge of the flight deck near the battery position for the associated catapult. The operator initiating the suspend must immediately inform the launching officer of the reason for the suspend. The launching officer shall determine the action to be taken for resolution. If the suspend action occurs prior to aircraft hookup, the aircraft shall be held short of the hookup position until the problem has been rectified or the catapult is placed in the down status. If a suspend occurs after an aircraft has been tensioned, the following apply:

1. The safety observer signals suspend to the pilot and other members of the aircraft launching team.
2. The launching officer shall immediately depress the suspend pushbutton.
3. The safety observer shall ensure that the deck suspend light is on and signal the launching officer to maneuver aft.
4. The launching officer depresses and holds the maneuver aft pushbutton until the grab and shuttle are moved fully aft.
5. After the shuttle has moved aft, the safety observer signals the pilot to raise launch bar.
6. For aircraft with NGL selector switch (F/A 18 and S-3):
 - 1) With the launch bar raised, the safety observer gives the bridle tension signal to the launching officer.

- 2) The launching officer depresses the bridle tension pushbutton to position the shuttle forward of the launch bar. When the shuttle has moved forward of the launch bar, the launching officer shall momentarily press the maneuver aft pushbutton.
 - 3) The safety observer shall step in front of the aircraft and in view of the pilot, give the throttle back signal.
7. For aircraft with manual launch bar (E-2 and C-2):
- 1) After the shuttle has moved aft, the safety observer shall ensure that the catapult is in the suspend condition, step in front of the aircraft and in full view of the pilot, give the throttle back signal.
 - 2) With the aircraft at idle power the safety observer directs the topside safety petty officer to approach the aircraft and manually hold the launch bar high enough to permit shuttle clearance.
 - 3) With the launch bar held clear, the safety observer gives the bridle tension signal to the launching officer.
 - 4) The launching officer depresses the bridle tension pushbutton to position the shuttle forward of the launch bar. When the shuttle has moved forward of the launch bar, the launching officer shall momentarily depress the maneuver aft pushbutton.
8. At this time, if the condition that initiated the suspend action has been corrected and the aircraft and catapult are both up, the shuttle may be maneuvered aft, launch bar lowered and the aircraft hooked up to the catapult.

NON-INTEGRATED CATAPULT CONTROL STATION (ICCS) SUSPEND PROCEDURES

A catapult launch can be halted at any time up until the fire pushbutton has been depressed by actuating a catapult suspend switch. Suspend switches are located at pri-fly, deckedge, main control console, and the water brake station.

NOTE

If the suspend switch at the water brake station is actuated during catapult operations, breaking tension by energizing maneuver aft cannot occur. If this switch initiated a suspend action, the main control console operator shall

actuate suspend and direct the water brake station to release the water brake suspend.

The operator initiating the suspend must immediately inform the launching officer of the reason for the suspend. The launching officer shall determine the action to be taken for resolution. If the suspend action occurs prior to aircraft hookup, the aircraft shall be held short of the hookup position until the problem has been rectified or the catapult is placed in the down status. If a suspend occurs after an aircraft has been tensioned, the following apply:

1. The launching officer signals suspend to the pilot and other members of the aircraft launching team.
2. The deckedge operator shall immediately actuate the suspend switch and give the suspend signal.
3. The launching officer signals the deckedge operator to maneuver aft.
4. After the shuttle has moved aft, the launching officer signals the pilot to raise launch bar.
5. For aircraft with NGL selector switch (F/A 18 and S-3):
 - 1) With the launch bar raised, the launching officer gives the bridle tension signal to the deckedge operator.
 - 2) The deckedge operator depresses the bridle tension pushbutton to position the shuttle forward of the launch bar. When the shuttle has moved forward of the launch bar, the deckedge operator shall momentarily press the maneuver aft pushbutton.
 - 3) The launching officer shall step in front of the aircraft and in view of the pilot, give the throttle back signal.
6. For aircraft with manual launch bar (E-2 and C-2):
 - 1) After the shuttle has moved aft, the launching officer shall ensure that the catapult is in the suspend condition, step in front of the aircraft and in full view of the pilot, give the throttle back signal.
 - 2) With the aircraft at idle power the launching officer directs the topside safety petty officer to approach the aircraft and manually hold the launch bar high enough to permit shuttle clearance.

3) With the launch bar held clear, the launching officer gives the bridle tension signal to the deckedge operator.

4) The deckedge operator depresses the bridle tension pushbutton to position the shuttle forward of the launch bar. When the shuttle has moved forward of the launch bar, the deckedge operator shall momentarily depress the maneuver aft pushbutton.

7. At this time, if the condition that initiated the suspend action has been corrected and the aircraft and catapult are both up, the shuttle may be maneuvered aft, launch bar lowered and the aircraft hooked up to the catapult.

INTEGRATED CATAPULT CONTROL STATION (ICCS) HANGFIRE PROCEDURES

In the event the catapult does not fire within 10 seconds after the fire pushbutton is depressed, a hangfire exists. At this time, the launch sequence must be safety stopped and the aircraft removed from the catapult. The actions to be taken and the order in which they are accomplished are paramount to the success of the procedure.

WARNING

If a hangfire occurs, the execution of the hangfire procedure must be accomplished. Even if the cause of the hangfire is quickly determined and can be easily resolved, the actions of all topside crew members and pilot are not known and interrupted firing of the catapult could have catastrophic consequences. The only corrective action authorized is the performance of the hangfire procedure.

1. The launching officer depresses the suspend switch and transmits to the charging panel operator via the monitor operator, "rotate the emergency cutout valve, rotate the emergency cutout valve." The launching officer shall then inform the safety observer of the hangfire condition verbally and by hand signals in daytime or the red wand hangfire signal at night.
2. The safety observer shall remain in the crouched position and shall not take any action toward the removal of the aircraft until the

shuttle has moved aft and assurance is received that the catapult is safe.

3. The charging panel operator shall perform the following actions in exact order:
 - 1) Depress the suspend pushbutton.
 - 2) Remove the cotter pin and unscrew the pin from the emergency cutout valve.
 - 3) Rotate the emergency cutout valve to the emergency position.
 - 4) Depress and hold the maneuver aft pushbutton for 15 seconds.
 - 5) Report to the launching officer via the monitor operator that the catapult is safe.
4. The launching officer transmits verbally that the catapult is safe and signals the safety observer a thumbs up in daytime or a red wand signal at night.
5. If the shuttle did not move aft during the preceding steps, the launching officer shall direct the charging panel/retraction engine operator, via the monitor operator, to depress and hold the manual override on the maneuver aft valve for 15 seconds.
6. After receiving assurance that the catapult is safe and observing that the shuttle is aft, the safety observer steps in front of the aircraft and in view of the pilot, gives the throttle back signal. The normal suspend/abort are accomplished for aircraft removal from the catapult.
7. After aircraft removal from the catapult has been accomplished, the launching officer shall set the CSV command to a no-load setting and ensure that CSV confirmed and match lights come on.
8. The emergency cutout valve shall remain in the emergency position until the maintenance officer authorizes rotation of the valve to the normal position.
9. The catapult is placed in a down status until the cause of the hangfire is determined, corrected, and two satisfactory no-load launches accomplished.

NON-INTEGRATED CATAPULT CONTROL STATION (ICCS) HANGFIRE PROCEDURES

In the event the catapult does not fire within 10 seconds after the fire pushbutton is depressed, a

hangfire exists. At this time, the launch sequence must be stopped and the aircraft removed from the catapult. The actions to be taken and the order in which they are accomplished are paramount to the success of the procedure.

WARNING

If a hangfire occurs, the execution of the hangfire procedure must be accomplished. Even if the cause of the hangfire is quickly determined and can be easily resolved, the actions of all topside crew members and pilot are not known and interrupted firing of the catapult could have catastrophic consequences. The only corrective action authorized is the performance of the hangfire procedure.

1. The launching officer shall remain in the crouched position and signals in exact order:
 - 1) Suspend
 - 2) Hangfire
 - 3) Maneuver aft
2. The launching officer shall remain in the crouched position and shall not take any action toward the removal of the aircraft until the shuttle has moved aft and assurance is received that the catapult is safe.
3. The deckedge operator depresses the suspend switch and transmits to the main control console operator, "rotate the emergency cutout valve, rotate the emergency cutout valve."
4. The main control console operator shall perform the following actions in exact order:
 - 1) Depress the suspend pushbutton.
 - 2) Remove the cotter pin and unscrew the pin from the emergency cutout valve.
 - 3) Rotate the emergency cutout valve to the emergency position.
 - 4) Depress and hold the maneuver aft pushbutton for 15 seconds.
 - 5) Report verbally to the deckedge operator that the catapult is safe.
5. The deckedge operator upon receiving the assurance from the main control console operator, signals to the launching officer, the hangfire signal followed by thumbs up in daytime or a red wand signal at night.

6. If the shuttle did not move aft during the preceding steps, the deckedge operator shall direct the retraction engine operator to depress and hold the manual override on the maneuver aft valve for 15 seconds.
7. After receiving assurance that the catapult is safe and observing that the shuttle is aft, the launching officer steps in front of the aircraft and in view of the pilot, gives the throttle back signal. The normal suspend/abort are accomplished for aircraft removal from the catapult.
8. After aircraft removal from the catapult has been accomplished, the launching officer shall set the CSV command to a no-load setting.
9. The main control console operator shall depress the set pushbutton.
10. The emergency cutout valve shall remain in the emergency position until the maintenance officer authorizes rotation of the valve to the normal position.
11. The catapult is placed in a down status until the cause of the hangfire is determined, corrected, and two satisfactory no-load launches accomplished.

SAFETY PRECAUTIONS

There are certain safety precautions that must be observed by catapult-operating personnel, maintenance personnel, deck personnel, pilots, and other personnel stationed in the catapult area.

Flight Deck

Bridle (deck) tensioner pressure, as determined by calibration, must be precisely adjusted and maintained at all times. Pressures in excess of those specified may cause premature holdback.

In the event of a malfunction, suspend, or hangfire, the signal for throttle back must NOT be given to the pilot until bridle tension has been released and the launch bar is raised.

When attaching the aircraft to the shuttle, extreme care must be taken so that the launch bar properly engages the shuttle. The catapult officer must ensure that the aircraft is properly tensioned prior to launching.

Precaution should be taken by the pilot not to taxi hard against the holdback unit. This may result in a premature release.

At no time are personnel to walk in front of a tensioned aircraft.

If operation of the catapult is suspended for any reason, bridle tension should be released and the aircraft released from the shuttle.

The shuttle and grab must not be moved along the catapult track until the track slot has been inspected and found to be clear of obstructions and all adjacent areas are clear of loose gear. Using the maneuver forward and aft push buttons, slowly move pistons forward and aft while all sheaves are visually checked to ensure the cables are not sliding over any locked sheaves.

All personnel must be kept out of areas forward of an aircraft positioned on the catapult, and clear of the shuttle track area during a no-load firing. All personnel must be kept clear of the area immediately behind the jet blast deflectors during aircraft turnups and launching.

During night operations, do not attempt to speed up the prelaunch check of catapult components or take unnecessary chances in an effort to maintain rapid aircraft launching intervals. Sufficient time should be taken to double-check each step to prevent accidents due to faulty hookups, misinterpreted signals, and other causes.

ICCS, CCP, Deckedge and/or Main Control Console

Retraction must not be undertaken unless the water brakes are operating properly and the grab and shuttle are latched. During preheating and throughout launching operations, the difference in elongation between the two launching engine cylinders must NOT exceed 1 inch. The catapult must NOT be fired with the shuttle out of BATTERY.

The shuttle must NOT be retracted with steam in accumulators unless the water brakes are functioning.

Do not advance the grab with spears out of the water brakes because possible grab latch damage may result, due to impact. Therefore, use the maneuver forward push button to advance the grab until it engages the shuttle.

Water Brakes

If the water-brake cylinder elbow pressure drops below minimum value the water brakes should be suspended and the CCP/main control console operator notified immediately. The malfunctioning water-brake pump should be secured and the standby pump started.

Do not allow excessive oil to accumulate on top of the water in the water-brake reservoir. Skim off the oil, or remove it by adding fresh water and allowing the oil to flow out the overflow drain.

NOTE

During in-port periods, do not skim the water-brake tanks or allow the water level to reach the overflow pipe. Maintain the water level by use of bottom tank drains. This is to prevent oil from being dumped into harbors.

Retraction Engine

All loose gear and tools must be kept clear of the retraction engine and cable system. Maintain all pressures at predetermined settings.

If any malfunction is observed during the advance of the grab or the retraction of the shuttle and grab, immediately SUSPEND the retract engine and notify the CCP/main console operator. All sheaves must be inspected for freedom of motion before beginning a series of launchings.

General

Operating personnel should wear appropriate protective clothing to prevent burns from steam or from contact with hot metallic surfaces. Earplugs should be worn in areas of high noise level.

The entire hydraulic system must be vented thoroughly and frequently, particularly after extended periods of idleness. Air in the fluid system may cause unpredictable variations in catapult performance and delays in actuation of operating components.

Combustible and volatile fluids and materials must be kept away from heated catapult parts to reduce the hazard of fire and explosion. Adequate ventilation must be provided below flight deck level to prevent the accumulation of explosive vapors.

If a hangfire occurs, personnel must not pass forward of the aircraft until all danger of a delayed launching has passed.

The catapult must NOT be operated with any known broken lockwires, loose or cracked components, major hydraulic leakage, defective reeving, or electrical control malfunction.

During any type of launching, live steam escapes from the track and brake areas. As this steam can cause severe scalding of exposed areas of the body, personnel in the area must avoid contact with it. When the catapult is in operating status, exposed metallic parts, such as track covers, launching and exhaust valves, and steam supply piping, may be hot enough to burn exposed areas of the body on contact. Therefore, operating personnel with duties in these areas should be equipped with appropriate protective clothing.

Aircraft launchings must NOT be made if the required minimum cylinder elongation has not been attained. An exception to this rule may be made under emergency conditions when wind-over-deck requirements have been increased as specified in applicable *Aircraft Launching Bulletins*.

Aircraft must not be launched at weights and wind requirements other than those specified in applicable *Aircraft Launching Bulletins*. Maximum loading of aircraft as specified in the *NATOPS Manual* for each type of aircraft, must be adhered to at all times.

Inspect all pumps and their limit switches and safety valves. Failure of safety devices can result in dangerous overpressures if the pump continues to operate. This condition may result in rupture of hydraulic pneumatic lines and danger to personnel.

SECURING THE CATAPULT

At the completion of aircraft launching operations, the catapult officer shall decide what state of catapult readiness will be maintained. Depending on operational requirements, one of the following readiness conditions will be established:

Ready

The order to maintain the catapult in a READY condition should be given when launching operations are intermittent or when certain conditions make it necessary to keep the catapult in a state of preparedness for launching within seconds after an order is given.

In the READY condition, the catapult is kept in a fully operational status, as between launching cycles.

Standby

If the order for the STANDBY condition of securing is given, it usually comes after the day's launching operations are completed and there is no possibility of additional launching within 12 hours.

The post-launch duties and inspection must be performed according to the MRCs.

Shutdown

The order for SHUTDOWN condition of securing the catapult is given when the catapult is placed out of service for maintenance or when the ship is in port.

Cold Iron

When the catapult will not be required for launching operations for an extended period of time, or the steam system and preheat system must be secured and the components allowed to cool down.

INSPECTIONS AND MALFUNCTIONS

The entire catapult should be kept as clean as possible. It should be wiped down daily to remove excess grease, oil, and dirt. All catapult personnel should be constantly alert for any unusual sound or action of the machinery. Report any unusual condition to the catapult officer for immediate investigation.

Periodic Inspections

Prior to the first launching of each day's operations, execute the PMS preoperational inspection according to the MRCs.

After each day's operation, perform the PMS postoperational inspection according to the MRCs.

Other inspections must be conducted in addition to preoperational and postoperational. These inspections are also accomplished through the use of MRCs.

Prior to conducting an inspection or maintenance on catapult equipment where an injury could occur from careless operation, make sure the following safety precautions have been accomplished in the order indicated:

1. Disconnect the grab from the shuttle and move it fully aft.
2. Close the main steam supply to the steam accumulator.

3. Reduce steam pressure in the steam accumulator to atmospheric pressure.
4. Open the retraction-engine accumulator blowdown valve.
5. Station a safety person at the ICCS, CCP, main control console and deckedge control manning sound-powered telephones to prevent tampering with catapult controls.
6. Station a safety person at the retraction engine and the water-brake tank, manning sound-powered telephones.
7. Tag the steam-smothering valve "out of service."
8. Station a safety person on the flight deck (in the shuttle area) to prevent accidental movement of the shuttle while personnel are in the water-brake tank.

The preceding safety instructions must be strictly followed. Under any conditions when inspection of the water brakes area is undertaken, it is imperative that the control system remain in a SAFE position (exhaust valve open, grab aft).

Malfunctions

This section provides operating personnel with a guide to assist in isolating and correcting causes of malfunctions. During aircraft launch operations, malfunctions may occur that can be rapidly corrected if the cause is correctly determined. In other cases, corrective action may require extensive repairs, and it is important that operating personnel rapidly isolate the cause of the malfunction in order to inform the catapult officer if the catapult must be placed out of service.

When a malfunction occurs, the catapult must be put in a SAFE condition before corrective action is attempted, to prevent accidental launching of aircraft or injury to personnel.

To properly correct any malfunction(s) all primary causes should be checked first to quickly isolate the malfunction to a specific system. The secondary causes can then be checked to determine which component(s) within the system caused the malfunction.

All preoperational and post operational inspection procedures that apply to a specific system or station of the catapult are to be conducted and completed by the person or persons assigned the duty. For detailed inspection procedures, the ABE must consult the applicable MRCs or technical manuals.

REVIEW QUESTIONS

- Q13. When are no loads conducted?*
- Q14. A hangfire exists when the catapult does not fire within what amount of time after the fire pushbutton has been pressed?*

SUMMARY

We have described functions and operations of the major catapult systems, descriptions of ICCS, central charging panels, main control consoles, and general maintenance procedures. For a more detailed study of the catapult systems and components, see the applicable NAVAIR technical manuals with the latest revisions.

CHAPTER 5

ASSOCIATED LAUNCHING EQUIPMENT

The associated launching equipment discussed in this chapter is used in conjunction with catapults and arresting gear. This equipment includes the jet blast deflectors and nose gear launch equipment.

JET BLAST DEFLECTORS

LEARNING OBJECTIVES: Identify the components of the jet blast deflectors. Describe the operation of the jet blast deflectors. Describe the emergency operations of the jet blast deflectors.

The jet blast deflector (JBD) installation consists of water-cooled panels that are mounted flush with the flight deck. The panels are raised and lowered by hydraulic cylinders connected to mechanical operating gear. When raised, the JBDs serve to protect personnel, equipment and other aircraft from the hot jet exhaust created by an aircraft spotted on the catapult. Seawater, supplied from the ship's firemain, is continuously circulated through the modules of each panel assembly to prevent overheating. Figure 5-1 shows the basic operation of JBDs.

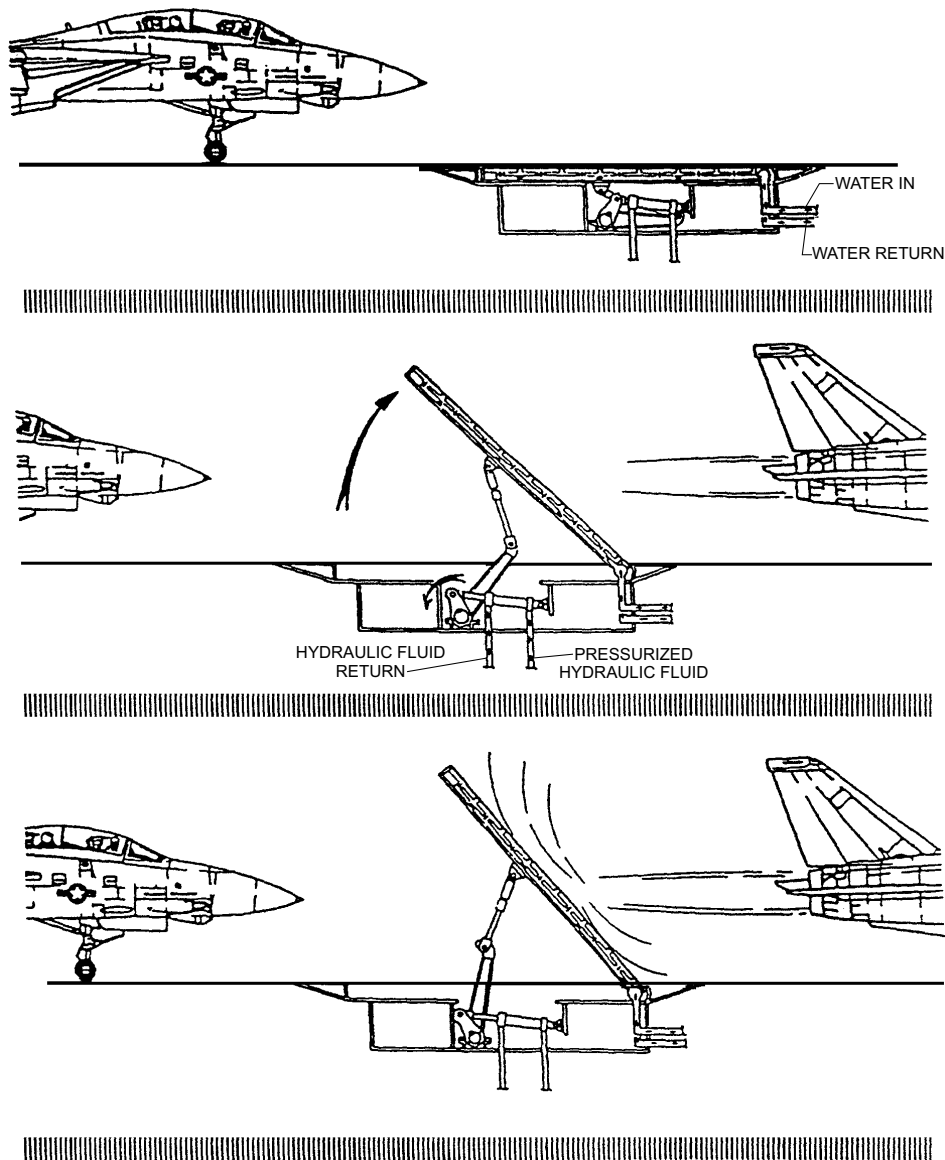

Figure 5-1.—Jet blast deflector operations.

ABEF0501

Jet Blast Deflector Assembly

The JBD assembly (fig. 5-2) consists of a series of water-cooled panels and operating gear assemblies. The Mk 7 Mod 0/2 JBD assembly is comprised of six panel assemblies with three sets of operating gear while

the Mk 7 Mod 1 JBD assembly has four panel assemblies and two sets of operating gear. The Mk 7 Mod 2 JBD contain two additional sideplate cooling panels. The sideplate cooling panels provide additional cooling which helps to prevent warping of the JBD panels.

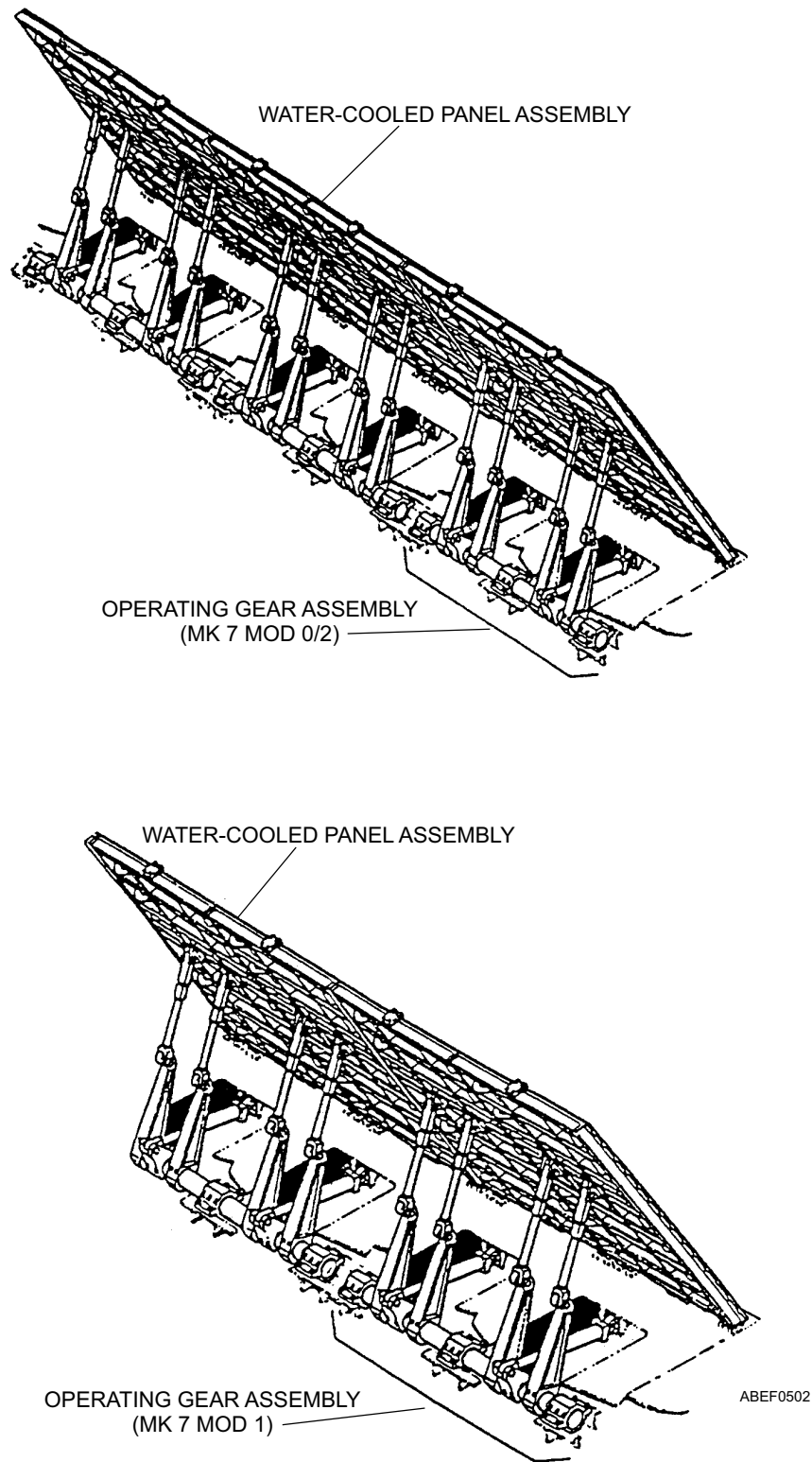

Figure 5-2.—Jet blast deflector assembly.

Regardless of the JBD installation, the operation is the same. A pair of JBD panels is connected to a set of operating gear. The panel assemblies can be raised independently or simultaneously with others in the same installation. By connecting a pair of panels to a set of operating gear, one cylinder can raise or lower a pair of JBD panels in the event of a failure to the other cylinder.

Operating Gear Assembly

The operating gear assembly (fig. 5-3) provides the means of physically raising and lowering the JBD panels. A set of operating gear consists of two hydraulic cylinders, three bearing blocks, one trunnion shaft, two crank assemblies and four linkage assemblies. Each linkage assembly consists of an arm, strut and eye. The linkage for two JBD panels is connected to a single

shaft. This method of attachment permits raising and lowering the JBD panels in pairs. The trunnion shaft is mounted and supported by the three bearing block assemblies. The two hydraulic cylinders are connected to the to the trunnion shaft by means of the crank assemblies.

Movement of the hydraulic cylinder piston rods rotates the shaft. Rotation of the trunnion shaft extends or retracts the linkage to raise or lower the JBD panels. Magnets, attached to the linkage arm and eye assemblies, actuate limit switches mounted to brackets on the side of the operating gear deck cutouts to indicate position of the panel assemblies. Removable panel supports can be attached to the operating gear and flight deck to lock panels in the raised position for maintenance, or if access to the area beneath the panels is required.

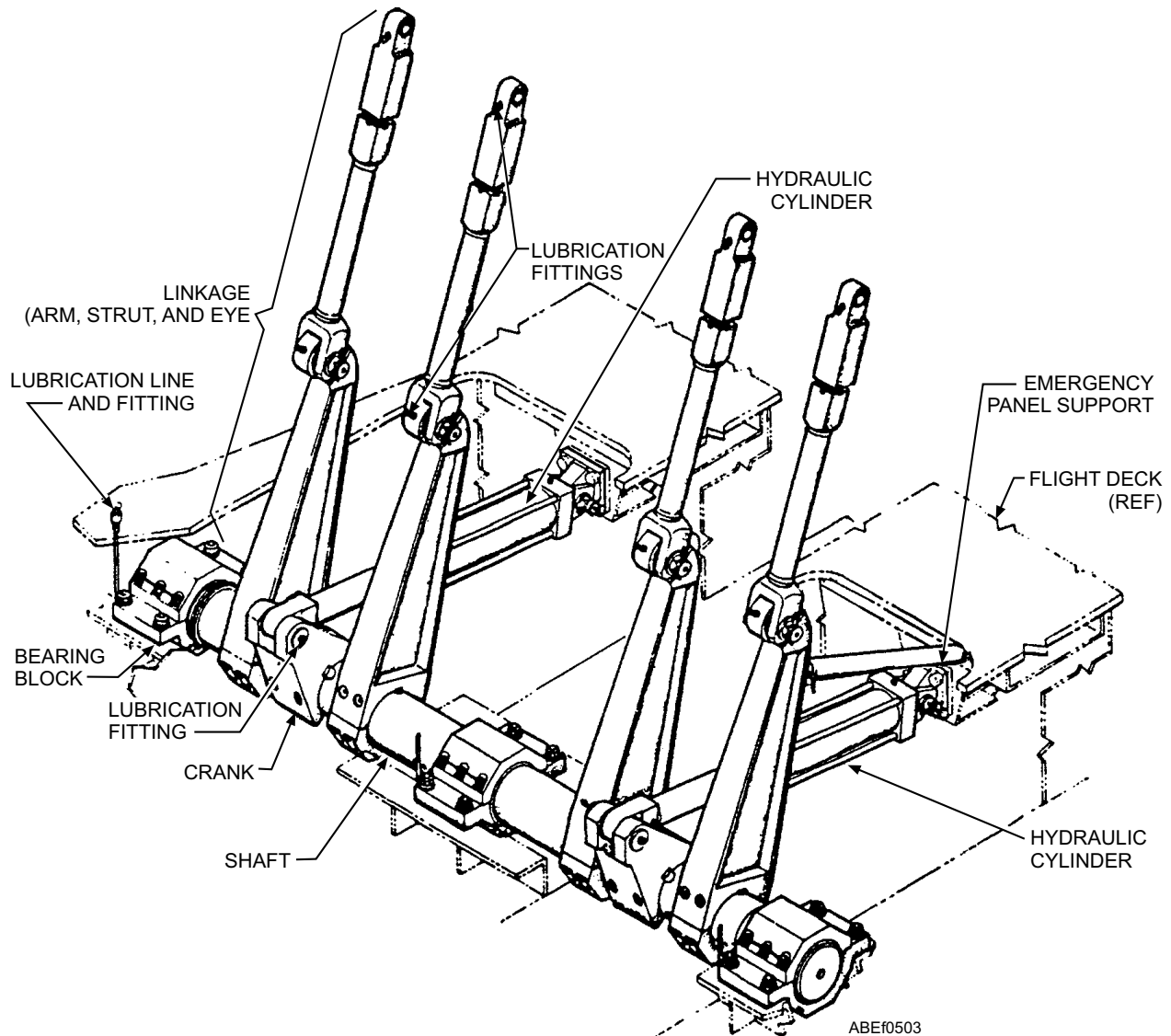

Figure 5-3.—Operating gear assembly.

Water-Cooled Panel Assembly

A water-cooled panel assembly (fig. 5-4) is a reinforced ribb-based aluminum alloy structure containing water inlet and outlet piping. Each panel assembly contains 14 tube assemblies and 7 removable module assemblies and attached hinge and lift fittings.

The module assemblies are fastened to the panel base by screws, thereby permitting easy removal in the event of module failure. Each module contains water passages connected to inlet and outlet water manifolds by tube assemblies. Seawater, supplied from the ship's firemain is continuously circulated through the individual module assemblies to dissipate heat

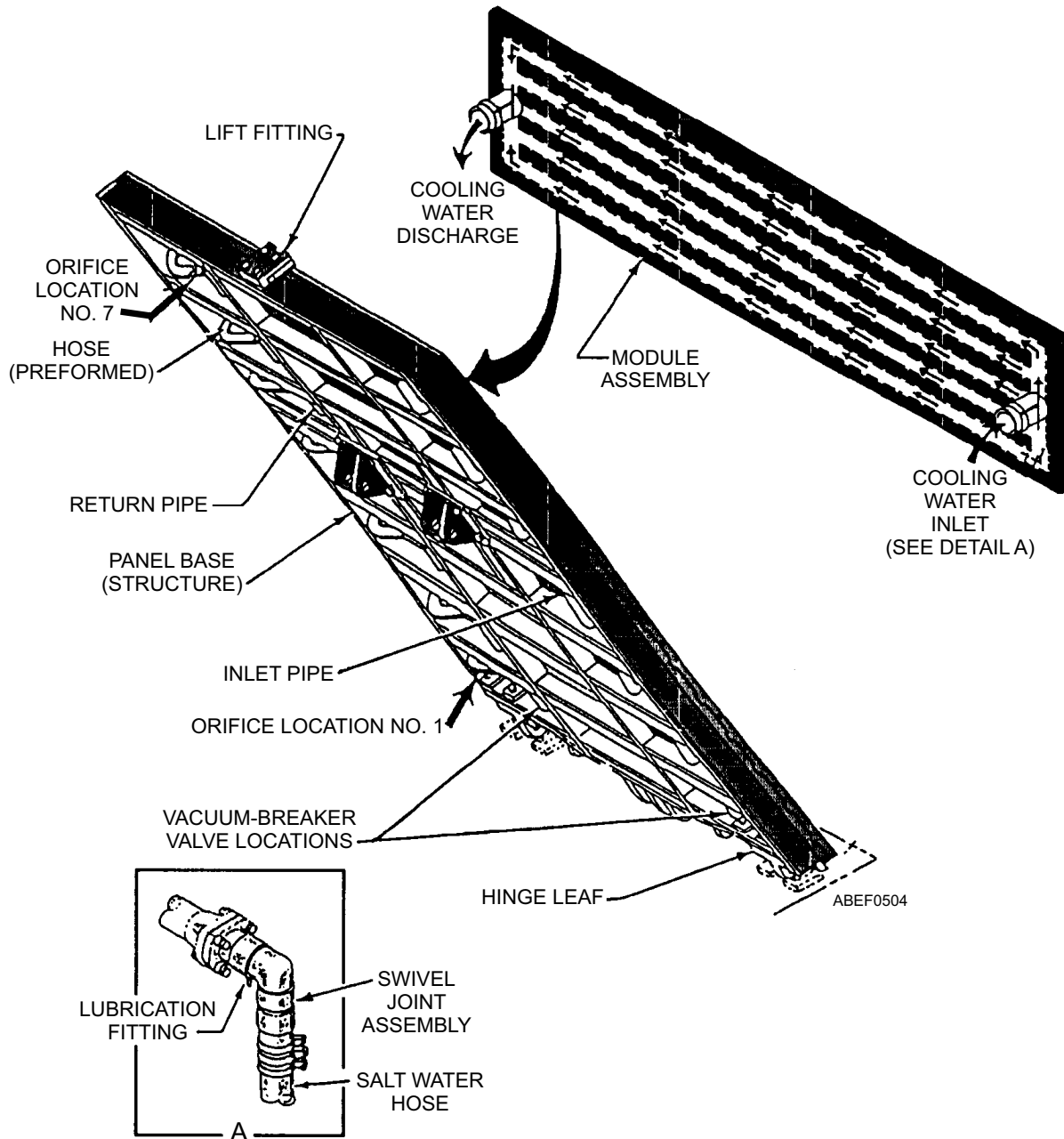

Figure 5-4.—Water-cooled panel assembly.

generated by jet exhaust. An orifice located in the return line connection of each module controls the flow rate of cooling water within the module assemblies. A removable hinge protector plate located below the bottom module of each panel assembly, permits easy access to the hinge bearing and fitting for maintenance.

Cooling Water Piping Installation

The cooling water piping installation (fig. 5-5) consists of a strainer, swivel joint assemblies, orifice flange assemblies, temperature switch, pressure switch, pressure gauges and associated piping and connections. Seawater, supplied by the ship's firemain, is continuously circulated through each module assembly and then discharged overboard. The strainer removes particles, which could clog water passages in the modules. The swivel joint assemblies provide a means of connecting the water manifolds, via hoses, to the seawater supply piping. The swivel joint also permits rotational movement of the piping as the JBD is raised or lowered. Two orifices flange assemblies are provided to regulate the cooling water flow rate. The inlet orifice

flange is not used and cooling water flow at that location is line sized. The outlet flange assembly orifice is sized to provide a flow rate of approximately 1,200 gallons per minute.

A temperature switch, located near the water discharge of one of the center JBD panels, will close if the cooling water reaches 210°F and alert the JBD operator by lighting a red temperature light on the control panel. A pressure switch, located in the line leading to the overboard discharge, will close if the water pressure drops below the setting that determined adequate flow rate and alert the JBD operator by lighting a red pressure light on the control panel. Pressure gauges, located on the control panel, provide an indication of cooling water pressure being supplied by the ship's firemain. The cooling water pressure must be maintained at a minimum of 90 psi. An additional pressure gauge, located upstream of the discharge orifice, is provided. A drop in pressure at this gauge indicates blockage within the cooling water system or inadequate firemain pressure. During JBD certification, the normal discharge pressure and pressure switch setting is determined.

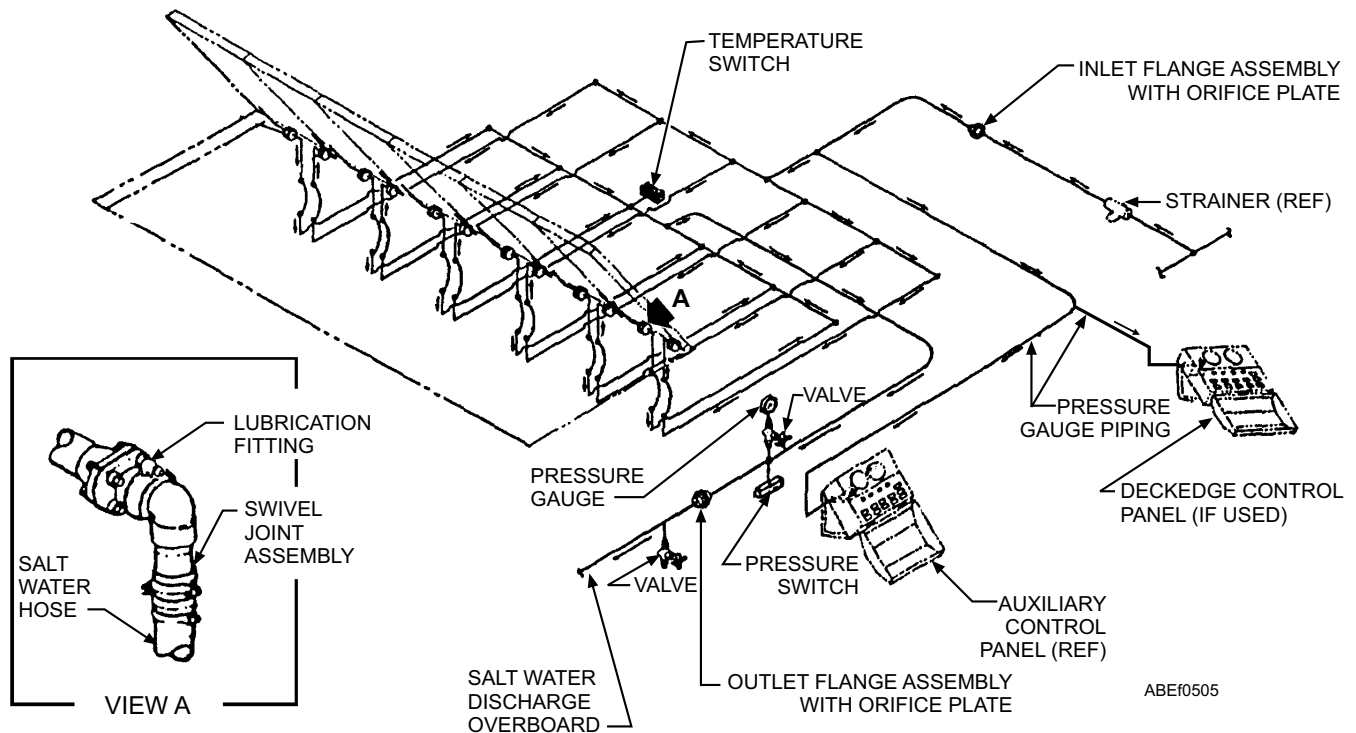

Figure 5-5.—Cooling water piping installation.

Hydraulic Control Piping Assembly

The hydraulic control piping assembly (fig. 5-6) consists of the control valves (stack valves), hose connections, and associated piping and fittings. Hydraulic fluid is provided to the JBDs by an inlet line and shutoff valve connected to the main catapult hydraulic system. The inlet branches off into three lines (Mk 7 Mod 0/2) or two lines (Mk 7 Mod 1) with each line connecting to a stack valve. The stack valve controls the flow of hydraulic fluid to and from the hydraulic cylinders. Emergency-lowering bypass lines and valves are connected to the raising side of each

cylinder and to the gravity tank return lines. The bypass lines permit routing of fluid around the stack valve and are only used during an emergency situation to lower the JBD panels.

An orifice assembly is provided in the line to the raising side of the hydraulic cylinders which maintains control of fluid flow for both the raising and lowering sequence. Shutoff valves are located in each line of the hydraulic cylinders for emergency and maintenance purposes. Hose assemblies provide a flexible connection between the hydraulic cylinders and piping to compensate for movement of the cylinders during raising and lowering operations.

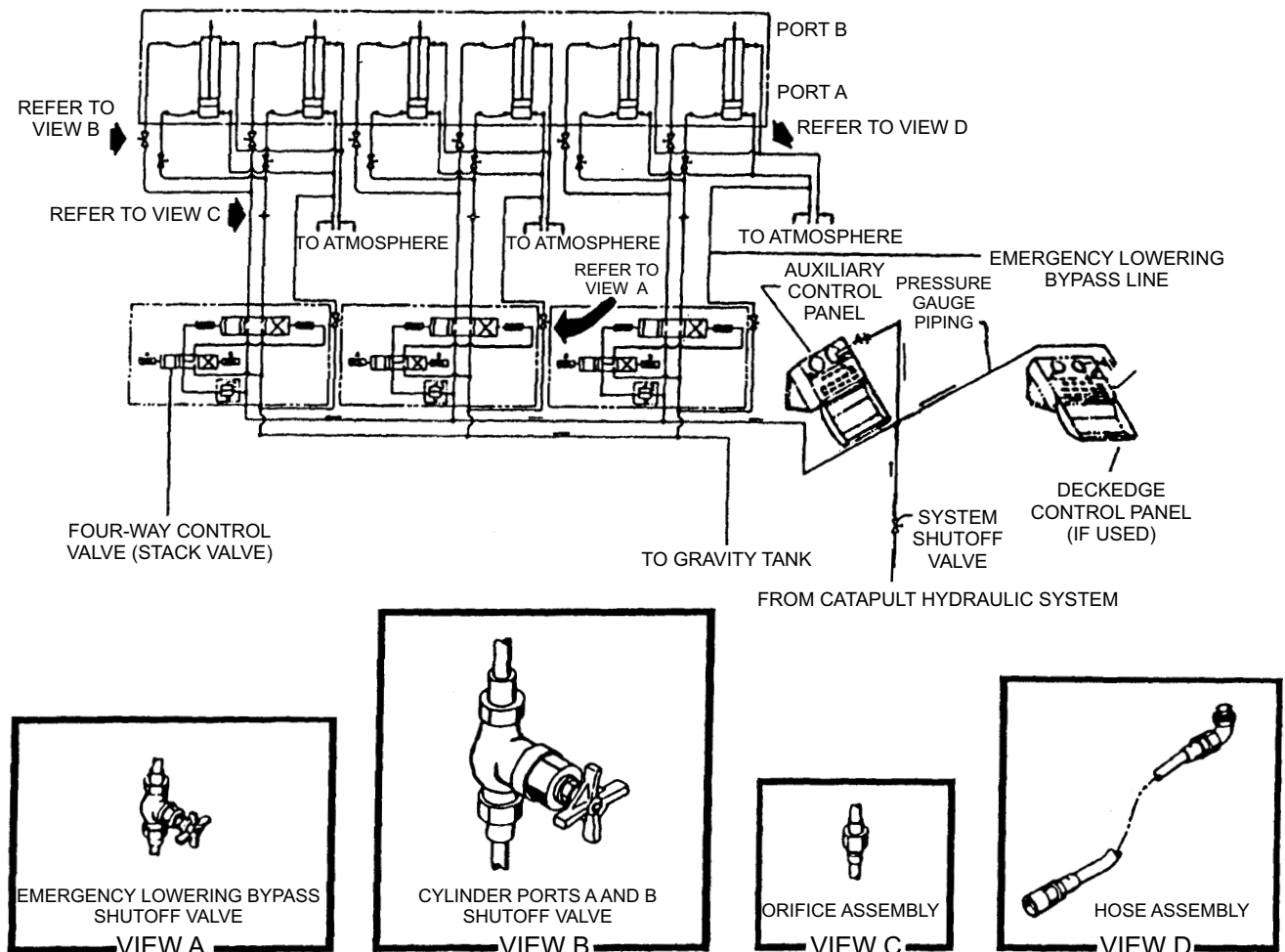

ABEF0506

Figure 5-6.—Hydraulic control piping assembly.

Four-way Control Valve (Stack Valve)

A four-way control valve (stack valve) (fig. 5-7) controls the flow of hydraulic fluid to and from a pair of hydraulic cylinders. The stack valve is a solenoid controlled, pilot-operated valve assembly. The stack valve consists of a solenoid-operated valve, a pilot-operated main valve, and a sequence valve. All three valves are secured together to conserve space and simplify connection to a subplate or manifold. One stack valve controls fluid flow for a pair of panel assemblies. Three stack valves are required for Mk 7 Mod 0/2 and two stack valves for Mk 7 Mod 1 JBDs. Hydraulic fluid at 2,500 psi from the associated catapult is supplied to the stack valve with all fluid return lines going to that catapult gravity tank. The operation of a stack valve is described as follows:

1. With hydraulic fluid at normal operating pressure and neither solenoid B (raise) nor solenoid A (lower) energized, fluid flows through the sequence valve and pilot valve to both sides of the slide in the main valve. This pressure to both sides of the slide keeps it centered and blocks fluid flow into and out of both ends of the hydraulic cylinders.
2. When a raise switch is actuated, solenoid B in the pilot valve energizes, shifting the spool and directing pressure to a pilot port at the main

valve side. The slide shifts and directs fluid to port A of both hydraulic cylinders. The hydraulic cylinder pistons extend, pushing the crank assembly of the operating gear aft and rotating the shaft. Rotation of the shaft extends the operating gear linkage and raises the associated panel assemblies. During the raise cycle, fluid in the cylinder lower port B vents to the gravity tank through the main valve. If the raise switch is released during the raise cycle, solenoid B deenergizes, a spring returns the solenoid spool to the centered position, and panel movement will stop. Fluid flow will be as described above in step a.

3. When a lower switch is actuated, solenoid A in the pilot valve energizes, shifting the spool and directing pressure to a pilot port at the main valve slide. The slide shifts in the opposite (from raising) direction and directs fluid to port B of both hydraulic cylinders. The pistons retract, pulling the crank assembly of the operating gear forward and rotating the shaft. The rotation of the shaft retracts the operating gear linkage and lowers the panels. During the lower cycle, fluid in the raise port A vents to the gravity tank through the main valve. . If the lower switch is released during the lower cycle, solenoid A deenergizes, a spring returns the

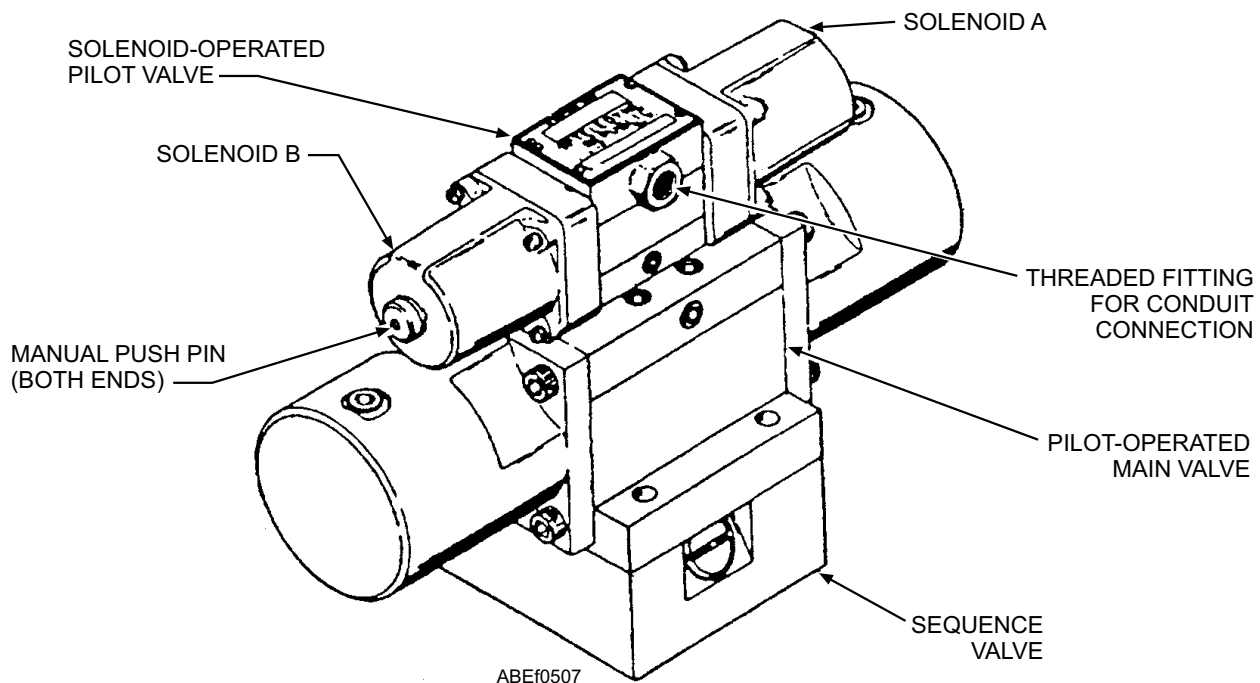

Figure 5-7.—Four-way control valve.

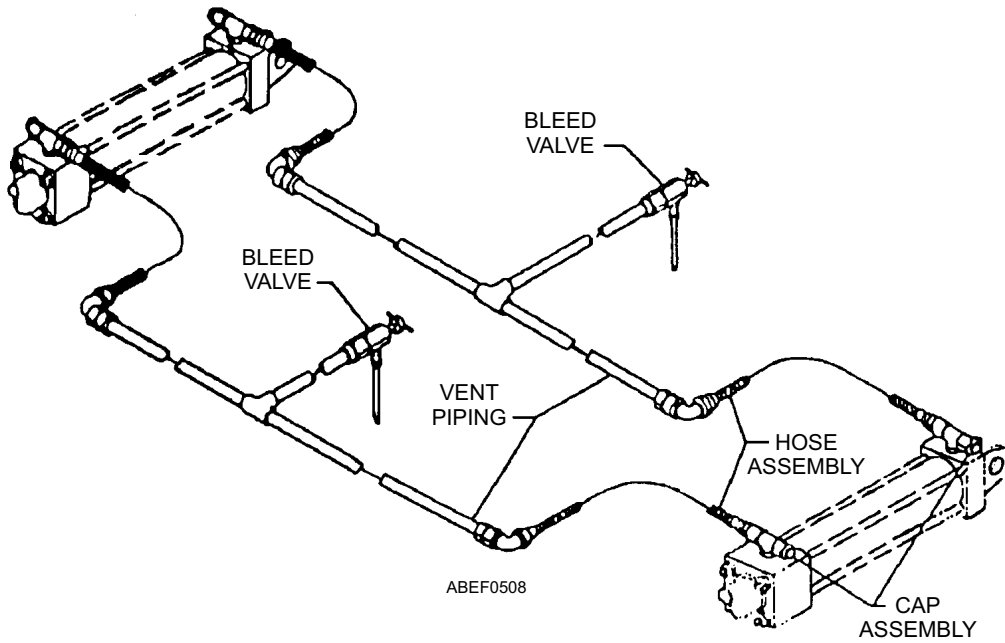

Figure 5-8.—Cylinder vent piping installation.

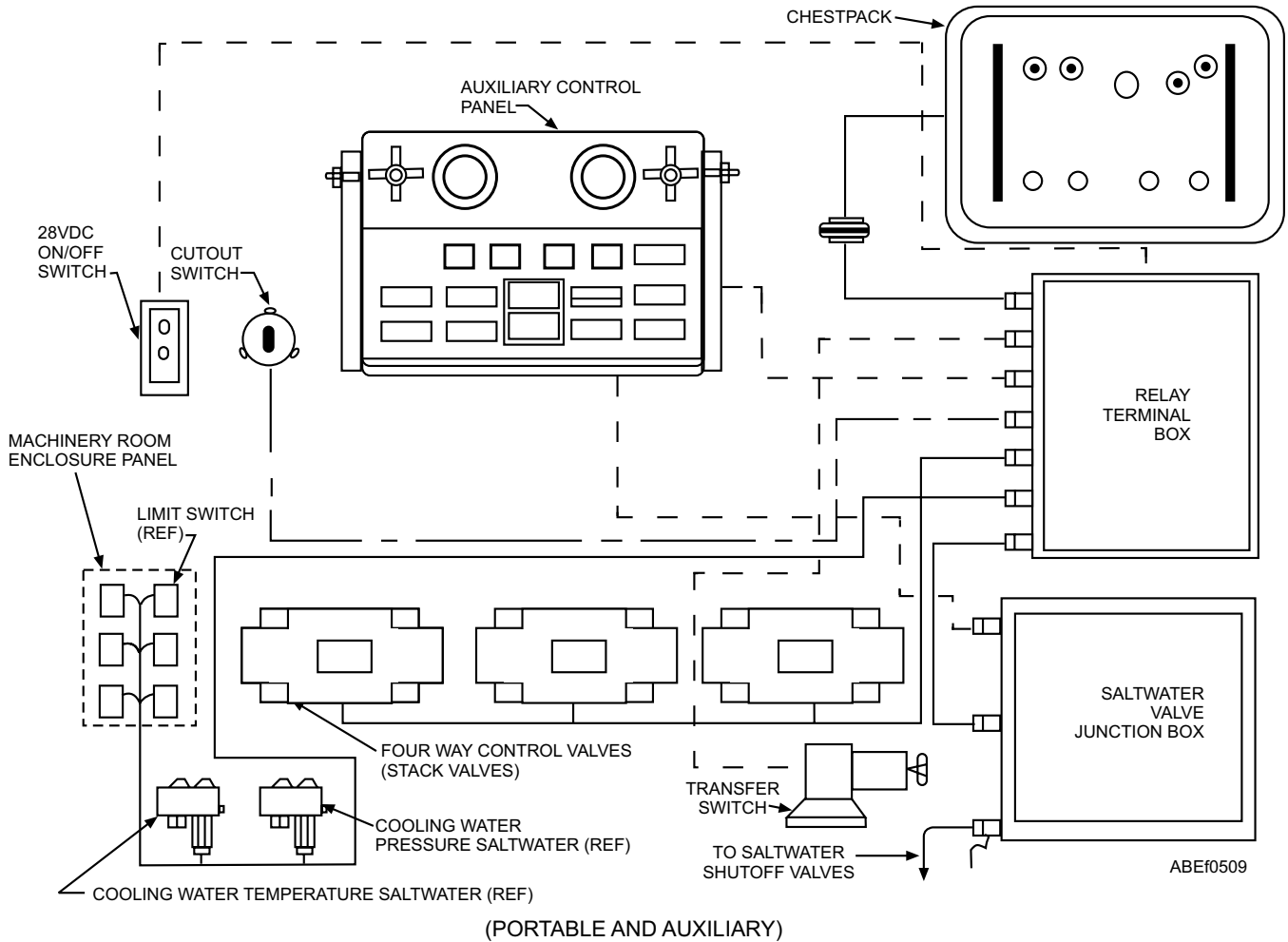

Figure 5-9.—Electrical control assembly.

solenoid spool to the centered position and panel movement will stop. Fluid flow will be as described earlier in step a.

Cylinder Vent Piping Installation

The cylinder vent piping installation (fig. 5-8) consists of bleed valves, flexible hose assemblies, piping, and associated fittings. Each JBD hydraulic cylinder is vented through flexible hoses connected to vent ports directly above the cylinder raising and lowering ports. The hoses also connect the piping to a nearby vent station and bleed valves.

ELECTRICAL CONTROL ASSEMBLY

The electrical assembly consists of the deckedge, auxiliary and portable (chestpack) control panels, a transfer switch, relay terminal box, cutout switch, and associated wiring and connectors. All JBD assemblies are electrically controlled by means of the individual control panels. Each control panel and chestpack has its own electrical installation and each is operated independently of the other. An auxiliary control panel and transfer switch, located below deck, is provided for emergency operating purposes. The auxiliary control panel is identical to the deckedge panel.

Deckedge and Auxiliary Control Panels

The deckedge and auxiliary control panels (fig. 5-10) are identical in design. The Mk 7 Mod 0/2 control panels contain nine light switches while the Mk 7 Mod 1 panels contain seven light switches. Each panel also contains four fuse lights, a power on light switch, double indicator light, a cooling water and hydraulic fluid shutoff valve, and a cooling water and hydraulic pressure gauge. Six switches (Mk 7 Mod 0/2) or four switches (Mk 7 Mod 1) are used to raise and lower the JBD panels. Two switches are push-to-test and the last switch is an emergency cooling water shut off valve light switch (water-emer-off). The water-emer-off switch, when actuated, closes a remote-controlled shutoff valve in the saltwater line leading to the applicable JBD assembly. The fuse light will provide an indication of a blown fuse and possible trouble in the applicable circuitry. The double indicator lights will provide an indication of low cooling water pressure or high cooling water temperature. A plastic guard, mounted over the up and down switches, prevents accidental operation of the panels.

Chestpack Portable Control Assembly

The chestpack (fig. 5-11) contains three individual raise and lower toggle switches, an “all” raise and lower toggle switch, a defeat interlock toggle switch, an emergency cooling water toggle switch, and a yellow water indicator light. Electrical power is provided by an umbilical cable connected to a receptacle on the rear of the chestpack and another receptacle located in the deck. The defeat interlock switch permits raising and lowering the JBDs during emergencies, such as low cooling water pressure or high cooling water temperature. The emergency cooling water switch, when actuated, closes a motor operated shutoff valve in the saltwater line leading to the applicable JBD assembly. The yellow cooling water indicator light, when lit, indicates a malfunction within the cooling water system. The three individual raise and lower switches allow the operator to raise individual pairs of panels while the “all” raise switch permits raising and lowering of all panels simultaneously. The red (port) and green (stbd) indicator lights show the operator to which JBD the chestpack is connected. All JBD installations currently use the deckedge control for JBD number four. Handles are provided on each chestpack to attach a harness worn by the JBD operator.

Transfer Switch (Chestpack Portable Control System)

The transfer switch (fig. 5-12) for the chestpack portable control is a rotary type with a rotary dial. The dial face is identified with two “portable” and two “aux” positions. The transfer switch is located near the applicable auxiliary control panel. When the transfer switch is in the portable position, the chestpack is operable. Moving the dial to the aux position shifts electrical power from the chestpack to the auxiliary panel.

Transfer Switch (Deckedge Control System)

The transfer switch is a rotary type switch with a rotary dial. The dial face is identified with two “deckedge” and two “aux” positions. The transfer switch is located near the applicable auxiliary control panel. When the transfer switch is in the deckedge position, the deckedge control panel is operable. Moving the dial to the aux position shifts electrical power from the deckedge panel to the auxiliary panel. The only difference between the chestpack and the deckedge transfer switch is the dial face.

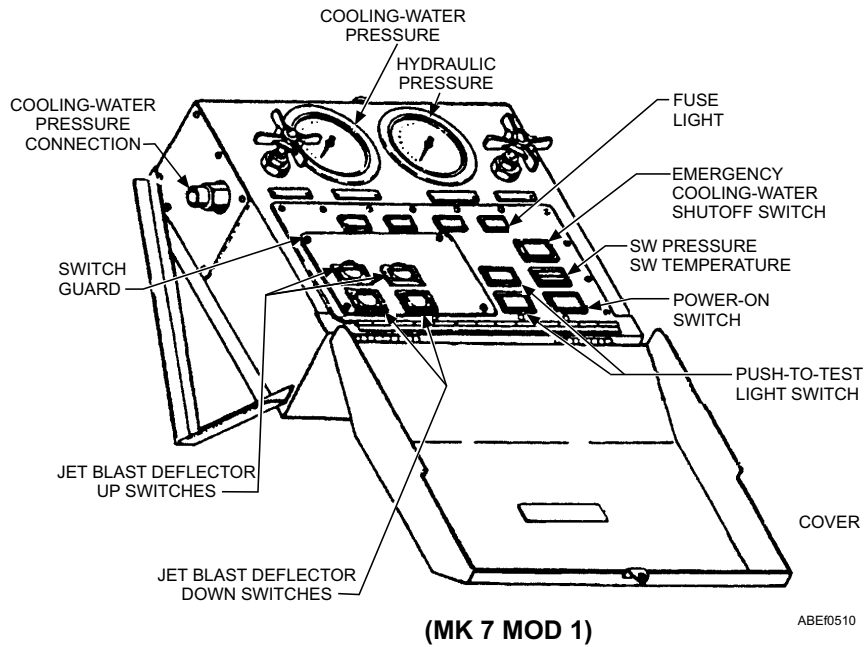
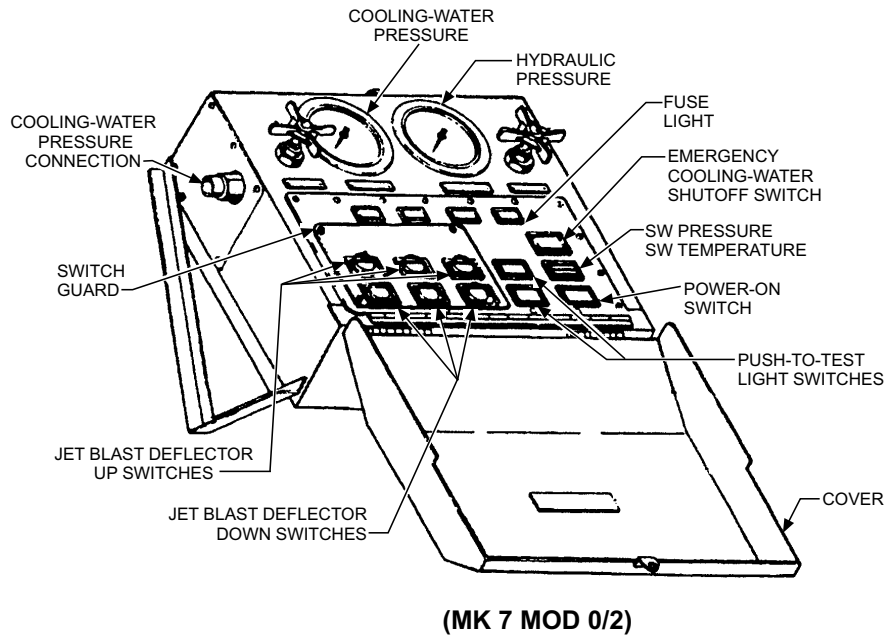

Figure 5-10.—Deckedge and auxiliary control panels.

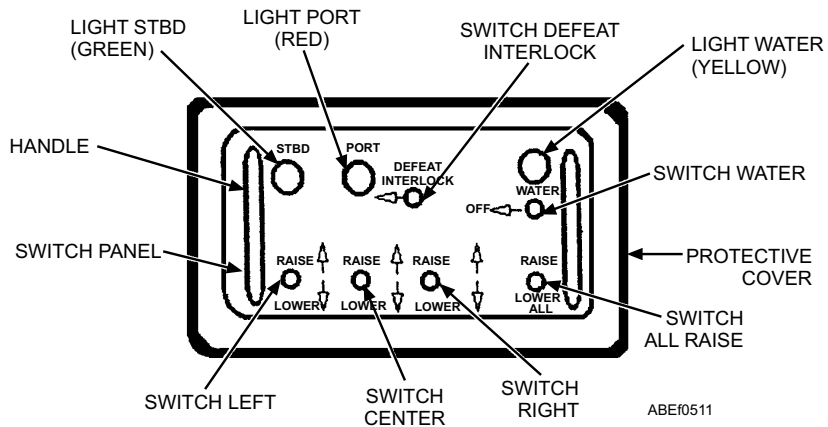
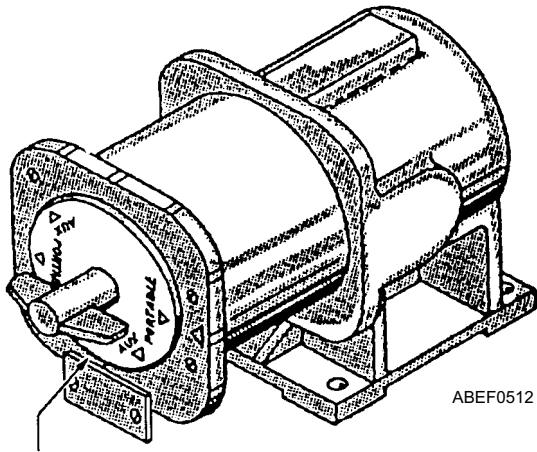

Figure 5-11.—Chestpack portable control assembly.

PANEL SUPPORT INSTALLATION AND EMERGENCY LOWERING DEVICE INSTALLATION



ABEF0512

ROTARY DIAL

Figure 5-12.—Transfer switch (Chestpack control system).

The panel support and emergency lowering device installation (fig. 5-13) consists of the panel support stanchions, panel supports, and an emergency lowering device. Panel support stanchions are to be used anytime panel supports are being installed or removed. The panel support stanchions are positioned between the raised JBD panel and lip of the flight deck. The panel support stanchion is designed to support the weight of a pair of fully raised JBD panels; however, the stanchion will not prevent the lowering of JBDs under pressure.

To provide a total margin of safety, panel supports must be properly installed prior to any maintenance

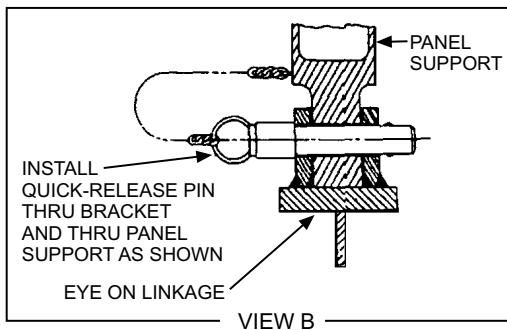

VIEW B

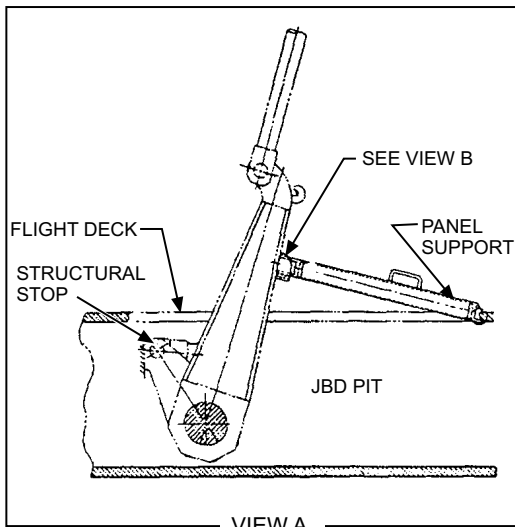

VIEW A

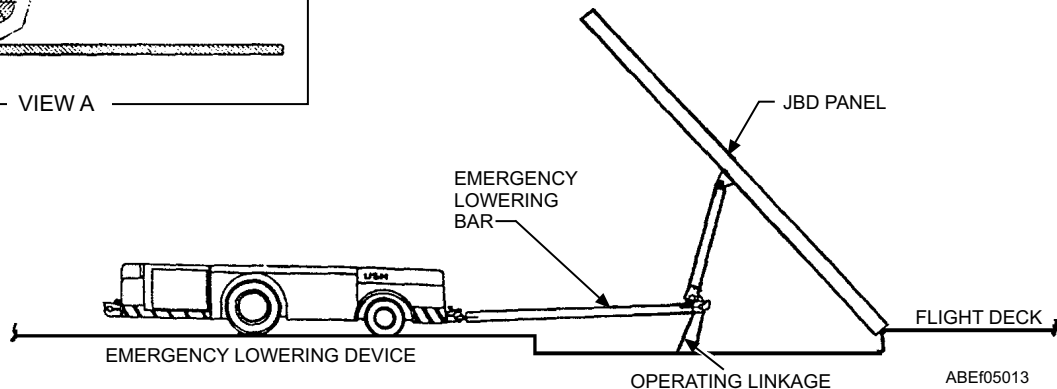
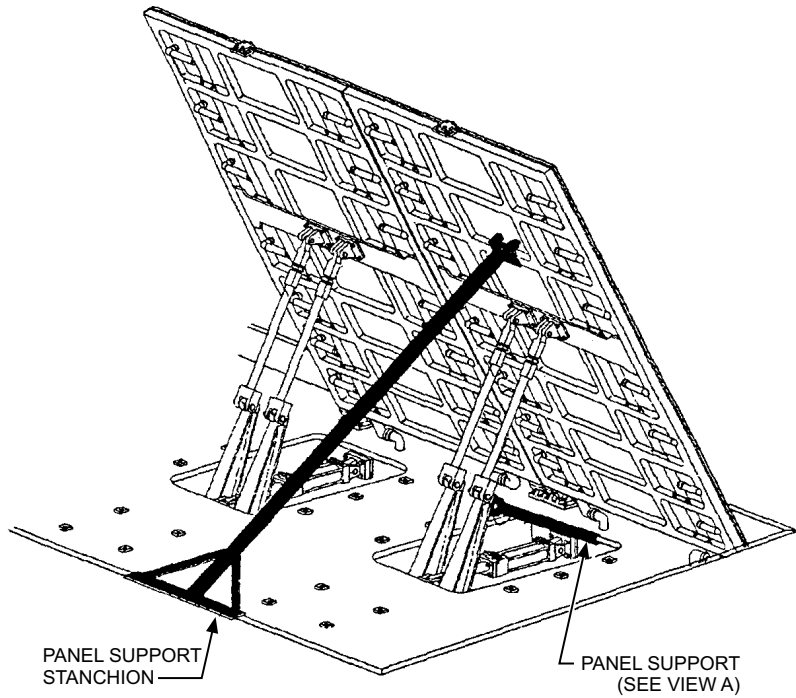

ABEF05013

Figure 5-13.—Panel support and emergency lowering installation.

being conducted under JBD panels. The panel supports attach to the JBD operating linkage arm assembly, with a quick release pin and fit into an indentation in the depressed deck area (JBD pit) at the forward end. The panel supports are used to lock panels in the raised position for maintenance purposes or emergencies. A panel support is provided for each set of operating gear, three supports for Mk 7 Mod 0/2 and two for Mk7 Mod 1 JBDs.

The emergency lowering device connects to a tow tractor on one end and fits against the operating linkage arm assembly at the other end. This allows the tractor to push the operating linkage “over-center”. With the emergency bypass valves open, the weight of the panels will then force fluid from the raise end of the hydraulic cylinders through the emergency bypass valve permitting the panels to slowly lower.

Preparation for Use

When the JBDs are put in operation for the first time or after being idle, use the following procedures:

1. Perform the preoperational inspection according to the applicable maintenance requirement card (MRC).
2. Ensure that personnel, aircraft, and flight deck equipment are clear of the panel area before attempting to raise the JBDs.

CAUTION

Damage by excessive heat can result from jet engine exhaust if cooling water is not flowing at the correct pressure.

3. Check to ensure salt water supplied from the ship's fire main is flowing through the water-cooled panels.
4. Functionally test the JBD hydraulic and electrical system for proper operation and leaks.

EMERGENCY OPERATION PROCEDURES

In the event of an emergency or a malfunction, the procedures discussed in the following paragraphs must be followed. The emergency lowering of a JBD will require a minimum of eight personnel:

- Topside Safety Petty Officer (overall in charge)
- Topside JBD phone talker

- Below decks phone talker/Valve operator
- Two personnel to install emergency lowering device
- Two safety observers (stationed at the port and starboard sides of the JBD panels)
- Tractor driver

Electrical Control Failure

Should the chestpack, deckedge, and auxiliary control panels become affected by an electrical power failure and the hydraulic system is functional, proceed as follows:

1. Station a crewperson to act as a valve operator at the stack valves. The valve operator shall be equipped with a sound-powered phone set. The chestpack or JBD deckedge operator shall remain at his or her station and relay instructions to the valve operator. The JBD deckedge or auxiliary panel operator shall also monitor the pressure gauges.
2. The valve operator, when instructed by the chestpack or JBD deckedge operator, shall raise or lower the JBD panels by the manual push pins of the A and B solenoids of the stack valves. The B solenoid controls the raising of the panels, and the A solenoid controls the lowering.

Hydraulic Control Failure

Should the JBD hydraulic system fail with the JBDs in the FULL-UP position, the following procedures must be used to lower the panels:

1. Establish sound-powered phone communication between the valve operator and the chestpack or deckedge operator.

WARNING

Ensure all tag-out procedures are according to current shipboard instructions.

2. Close the main supply valve and attach a safety tag.
3. Open the applicable emergency bypass valves one-quarter turn or as necessary to control the lowering speed of the panel.
4. Using the panel emergency-lowering device, place the fitted end against the panel linkage

arm and attach the ring end to a tractor tow hook. Push with the tractor until the operating gear linkage unlocks.

WARNING

Once the emergency lowering device is installed, all hands shall stand back at a safe distance from the JBD and around tractor. As the JBD begins to lower, the emergency lowering device will be dragged out of the JBD pit by the tractor utilizing reverse gear.

5. Adjust the panel lowering speed by opening/closing the emergency bypass valve.
6. Once the strut is over-center, the JBD panels will fall under its own weight until it is flush with the deck.

Inoperative Deckedge Control Panel or Portable Electrical System Control Box

In the event of an emergency where the chestpack or the deckedge control panel cannot be used, the auxiliary control panel becomes operational.

1. Station a crewperson at the flight deck or deckedge to man the phone and relay instructions to the auxiliary-control-panel operator.

WARNING

The crewperson, acting as a safety observer, should ensure that the area around the JBD is clear of aircraft, support equipment, and personnel.

2. With the transfer switch in the AUX position, the auxiliary-control-panel operator shall operate the panel by the instructions relayed to him or her from the flight deck or deck edge personnel.

CAUTION

Repair and checkout of the faulty panel or control box operation shall be accomplished at times when the raising or lowering of the JBD would not be prohibited by aircraft movement on the flight deck.

3. Continue operation of the auxiliary control panel until the faulty chestpack or deckedge

control panel is completely checked out and restored to proper operating condition.

WARNING

Prior to returning control back to deck operation, verify with the flight deck safety observer that the area around the JBD is clear of aircraft, support equipment, and personnel.

4. Return control of the JBD to the chestpack or deckedge operator.

MAINTENANCE

This section contains preventive and corrective maintenance information and procedures, some of which are general and apply to various items of the system and others which are specific and apply to a particular part of the equipment.

Planned Maintenance

The planned maintenance system furnishes all vessels and stations with MRCs containing specific maintenance instructions. These cards are used at required frequencies to maintain JBD equipment in operating condition and to prevent breakdown and subsequent shutdown of operations. The planned maintenance system and the maintenance data collection system are described in OPNAVINST 4790.4.

Current MRCs include the following inspection and cleaning procedures:

1. Preoperational inspections
2. Postoperational inspections
3. Cleaning and inspecting hydraulic piping orifice plate(s)

WARNING

Before performing any maintenance procedures behind a JBD panel in the raised position, install the panel supports to prevent the panel from lowering. Failure to do this could result in serious injury to personnel.

To ensure dependable operation of the JBD equipment, proper lubrication of the mechanical linkage is essential. Lubrication is part of the preoperational checks given in the MRC. Extension tubes are provided on trunnion bearings and hydraulic

cylinder bracket assemblies so that all lube fittings can be reached from the deck.

PROTECTING OPEN EQUIPMENT.—When removing a component from the hydraulic system, cap or plug all openings to prevent entry of foreign matter. Use tape to protect pipe threads.

CLEANING.—Hydraulic system components must be disassembled, cleaned, repaired, and reassembled as specified in the operation, maintenance, and overhaul instructions manual for the specific type of JBD installation on your ship.

WARNING

Before repairing or removing any components connected to hydraulic or water lines, make sure the lines are depressurized. Also, before repairing or removing any electrical component, de-energize the electrical circuit and attach an out-of-service tag.

HOSES, SEALS, AND O-RINGS.—Hoses, seals, and O-rings are selected on the basis of their compatibility with the hydraulic fluid. Therefore, replacement parts should be of the same material as original parts. O-rings must be removed and replaced with care to avoid damage to the O-ring and O-ring sealing surfaces of the various parts. O-rings must be free of cuts and not deformed. New O-rings must be installed at every reassembly of components. Before assembly, all O-rings must be lightly lubricated with the system hydraulic fluid. Hoses are subject to wear and require periodic replacement. When installing hoses, take care to avoid unnecessary bends and overstraining.

To restore the JBD system to operating condition after a down period that required draining fluid, perform preoperational inspection procedures given in the applicable MRC.

For most repairs to the hydraulic system, only portions of the system need be drained. Isolation valves in each of the hydraulic cylinder lines and a shutoff valve between the stack valve and the catapult pumps permit isolation of portions of the JBD hydraulic system.

Troubleshooting

Most problems that occur on JBDs can be recognized as a failure of one of three systems—namely, hydraulic, electrical, or water.

Information that allows operating and maintenance personnel to locate the source of problems or equipment failure is found in the JBD technical manual, in the section covering trouble shooting.

SAFETY PRECAUTIONS

The energy required to operate the JBD is supplied by fluid under pressure; therefore, when operating with fluid under pressure, observe standard safety precautions that apply.

All moving parts and equipment should be checked for rags, tools, or other foreign material before operating any of the machinery. Only qualified operators shall be allowed to operate the JBDs.

The parking of aircraft on the deflector panel should be avoided. The panels are designed to withstand only the temporary weight of the aircraft taxiing over them.

When you perform maintenance on the JBD, comply with the safety precautions listed on the MRC.

Personnel and equipment shall be clear of the JBD machinery enclosure and depressed deck when the panels are being raised or lowered. This includes the times when the panels are being operated during preoperational inspections and maintenance or overhaul tests and inspections.

REVIEW QUESTIONS

- Q1. What provides the means of physically raising and lowering the JBD panels?*
- Q2. Each Mk 7 Mod 0 JBD panel assembly consists of how many tube assemblies?*
- Q3. What permits rotational movement of the piping as the JBD is raised and lowered?*
- Q4. What is the maximum temperature of the cooling water?*
- Q5. What controls the hydraulic fluid to and from the hydraulic cylinders?*
- Q6. What type of valve is the stack valve?*
- Q7. What is the differences between the deckedge and the auxiliary control panel?*
- Q8. The double indicator light will provide what indication?*
- Q9. What is the function of the “all” raise switch on the chestpack portable control?*

- Q10. What is the function of the panel support?
- Q11. List the personnel required to perform a JBD emergency lowering?

MK 2 NOSE-GEAR-LAUNCH (NGL) SYSTEM

LEARNING OBJECTIVES: Describe the components of the Mk 2 nose gear launch system. Describe the operations of the Mk 2 nose gear launch system.

The nose-gear-launch (NGL) equipment is designed to assist in the launching of aircraft by providing a positive and automatic means of attaching the aircraft launch bar to the catapult shuttle and spreader. This method of launching permits a positive, automatic engagement of aircraft to catapult. Automatic engagement of the aircraft launch bar to the catapult reduces the number of personnel required to be in close proximity to the aircraft during catapult hookup.

The major components of the Mk 2 NGL system include the flush-deck guide track, slide assembly,

actuator reset assembly, shuttle spreader, and buffer cylinder assembly. These components and their operation are discussed in the following paragraphs.

NOSE-GEAR-LAUNCH GUIDE TRACKS

The guide tracks (fig. 5-14), which guides the aircraft launch bar into engagement with the catapult shuttle spreader assembly consists of an approach track, buffer-cylinder track, aft slide-access track, forward slide-access track, and a forward track. The approach track contains a V-shaped mouth, which guides the aircraft launch bar into the guide track. Grooves constructed in the individual tracks and top surface of the buffer cylinder guide the launch bar as the aircraft moves forward. Inserts installed in the forward slide-access tracks provide a camming surface, which ensures that the launch bar makes positive contact the buffer hook actuator roller. Inserts installed in the forward track guide the launch bar up and over the spreader assembly for proper launch bar to shuttle hookup.

Wheel guides bars are provided to guide the aircraft nose wheel along the guide track. The inner wheel

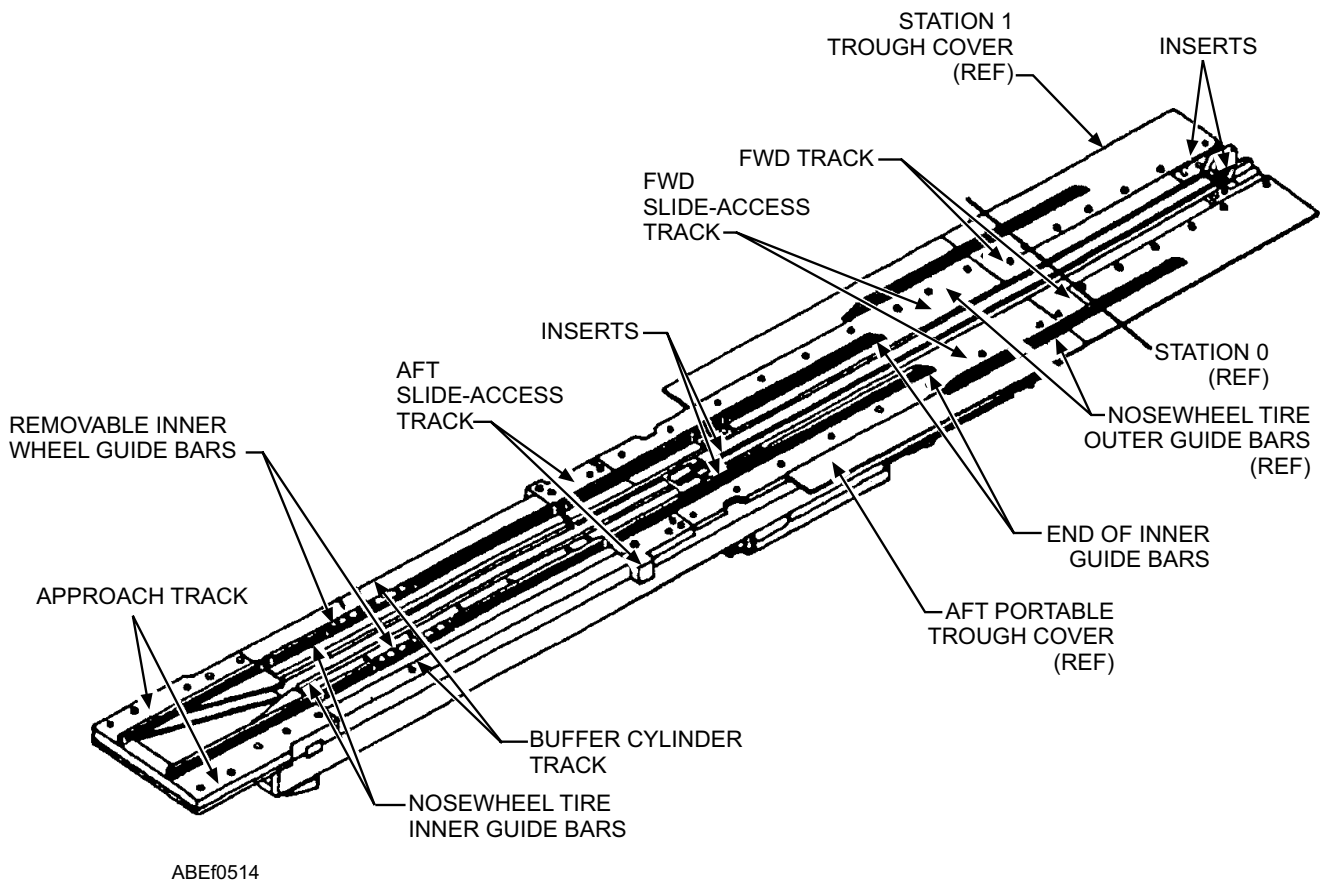

Figure 5-14.—Nose-gear-launch guide tracks.

guide bars keep the nosewheel straight during forward movement. The outer wheel guide bars prevent the nose wheel from sliding side to side once the nosewheel clears the inner guide bars and aid in proper alignment of launch bar to spreader assembly.

NOSE-GEAR-LAUNCH (NGL) ASSEMBLY

The NGL assembly consists of the slide assembly, reset assembly, forward and aft slide-access tracks, buffer cylinder assembly, tensioner cylinder assembly, housing, drain pan assembly, and a shock absorber.

Slide Assembly

The slide assembly (fig. 5-15) consists of a body containing rollers, which reduce friction during forward and aft movement of the assembly; the buffer hook, which engages the aircraft hold-back bar; and the buffer-hook actuator assembly, which raises the buffer hooks to flight deck level. The slide assembly is mechanically connected to the buffer-cylinder piston rods by three links.

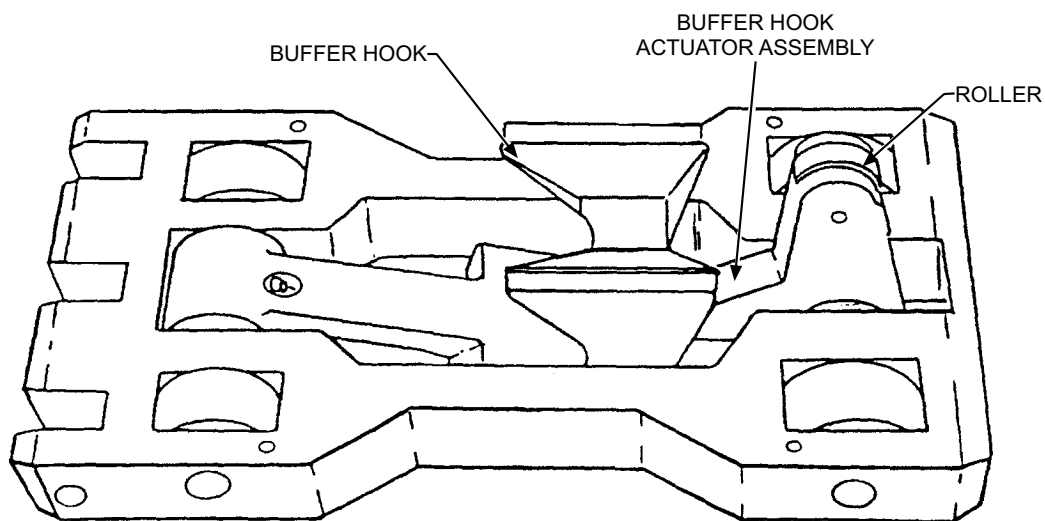
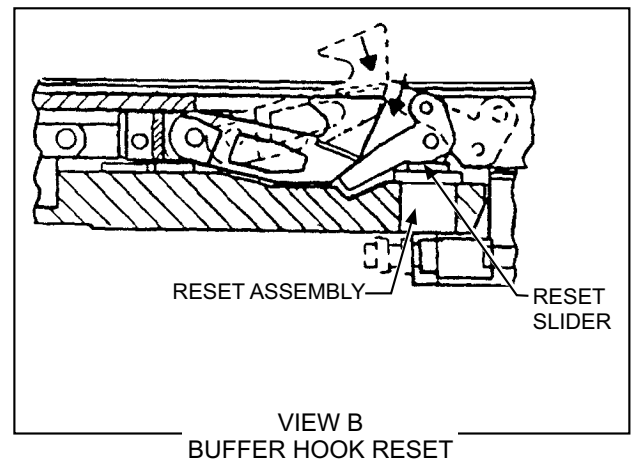
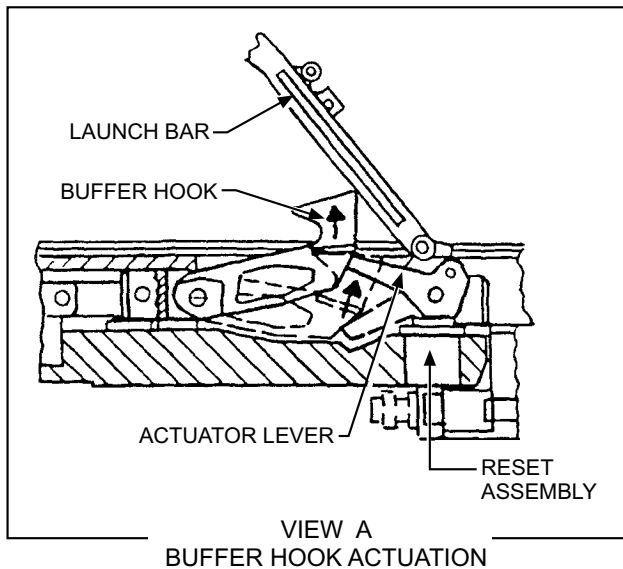

ABE0515

Figure 5-15.—Slide assembly.

During operation, (see view A, fig. 5-15) as the aircraft moves forward, the launch bar, sliding in the track-guide grooves, contacts the buffer-hook-actuator-assembly roller, forcing it to rotate forward and down. When the buffer hook actuator is forced down, its forces against the underside of the buffer hook and raises the hook into position to engage the aircraft holdback bar. As the aircraft continues forward, the holdback bar engages the buffer hook and pulls the slide assembly forward. The slide assembly, connected to the buffer cylinder piston rods, pulls the three rods from the buffer cylinder assembly. Hydraulic resistance within the buffer cylinder assembly decelerates the aircraft. When the aircraft stops, it is in position for catapult shuttle hookup.

After launch, the piston rods are retracted into the buffer cylinder assembly automatically. As the slide assembly moves aft, the buffer hook assembly contacts the reset assembly slider (see view B, fig. 5-15), causing the actuator lever to rotate down. This action permits the buffer hook to drop below deck level through an opening in the track into the deck housing. The slide assembly is now ready for the next aircraft hookup.

Reset Assembly

The reset assembly (fig. 5-16), which resets the buffer hook, causing it to drop below deck at the end of the buffer-cylinder-assembly retract stroke, is located below the slide assembly in the deck housing. The reset assembly consists of a housing, slider, slider actuating spring, and retainer. The slider contains a stellite

surface that reduces wear due to contact with the buffer hook actuator lever. Grooves machined in the top of the slider provide a path for the flow of lubricant between the slider and the inner walls of the housing. The housing is chrome-plated to prevent corrosion. The actuating spring is housed in a hole in the bottom of the slider. The slider and spring are secured in the housing by means of the retainer.

During operation when the slide assembly is forward, the reset-assembly slider is not restrained by the actuator assembly but is held above the surface of the housing by the slider actuating spring. After launch, as the slide assembly retracts, the buffer hook actuator contacts the extended reset slider, causing the actuator assembly to rotate downward. This action permit the buffer hook to drop below the deck through the track opening into the deck housing cavity (see view B, fig. 5-15). When the buffer hook is below deck, the actuator assembly lever holds the reset-assembly slider down in the reset assembly housing.

Forward and Aft Slide-Access Tracks

The slide-access tracks retain the slide assembly in the housing. They also serve to guide the aircraft launch bar to ensure proper engagement with the catapult shuttle spreader. Inner and outer guide wheel bars are attached to the aft and forward slide-access track to keep the aircraft nosewheel straight during forward movement of the aircraft. Inserts installed in the forward slide-access tracks provide a camming surface, which ensure that the launch bar contacts the buffer hook actuator roller.

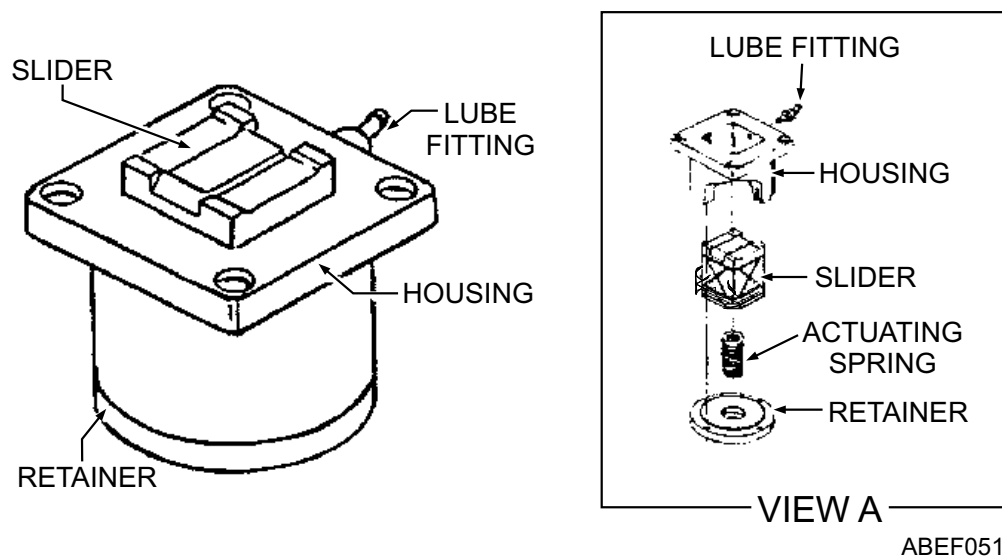

Figure 5-16.—Reset assembly.

Buffer Cylinder Assembly

The NGL buffer cylinder (fig. 5-17) is located in the deck housing between the approach track and the aft slide-access track. The buffer-cylinder body has integral guide tracks on its top surface and contains three hydraulic cylinders. The two outer cylinders contain hollow piston rods; the center cylinder piston rod is solid. The forward end of each piston rod is attached to the slide assembly. Within each outer piston rod is an orifice tube, which meters fluid flow through the outer cylinders to absorb the forward energy of the aircraft during the buffering stroke.

Prior to aircraft holdback bar/buffer hook engagement, the buffer cylinder assembly is in the standby cycle (fig. 5-18) with the three piston rods fully retracted into the buffer cylinders. While in the standby cycle, hydraulic fluid is constantly circulated between the hydraulic system and the buffer cylinder assembly through two metering orifice screws at a rate of approximately 8.5 gpm. This metered flow, which is nonadjustable, is to maintain the hydraulic fluid in the system at the proper temperature.

When the aircraft holdback bar engages the buffer hook, the slide assembly moves forward, pulling the three piston rods from the cylinders. As the piston rods move forward, fluid in front of each outer-cylinder piston is forced through the holes around the periphery of each outer-cylinder piston and through the metering holes in the two orifice tubes. As the pistons continue forward, the number of metering holes in the orifice

tubes is progressively reduced, causing an increasing resistance to forward motion of the slide assembly, thus decelerating and bringing the aircraft to a smooth stop at the end of the buffering stroke.

During the buffering stroke, fluid in front of the center-cylinder piston is forced through a port in the cylinder and through the hydraulic line into the NGL valve-manifold accumulator, which acts as a cushion and fluid reservoir. After launch, the fluid pressure established by the valve-manifold reducing valve acting on the forward side of the center cylinder forces the center piston aft, thus retracting the three rods into the cylinders.

Buffer Accumulator Assembly

The buffer accumulator assembly (fig. 5-19) is located below deck in line with and aft of the buffer cylinder assembly. The buffer accumulator consists of a hydraulic accumulator mounted in a support with a tee fitting and associated hardware.

During operation, as the buffer cylinder piston rods are pulled forward, hydraulic fluid flows from the accumulator, through the tee fitting and associated piping into the aft end of the buffer cylinder assembly filling the void created as the piston rods move forward.

After the launch, the buffer piston rods retract into the buffer cylinder forcing fluid from the buffer cylinder back to the accumulator. Fluid continues to flow into the accumulator until the pressure buildup exceeds the spring-load of the check valve located

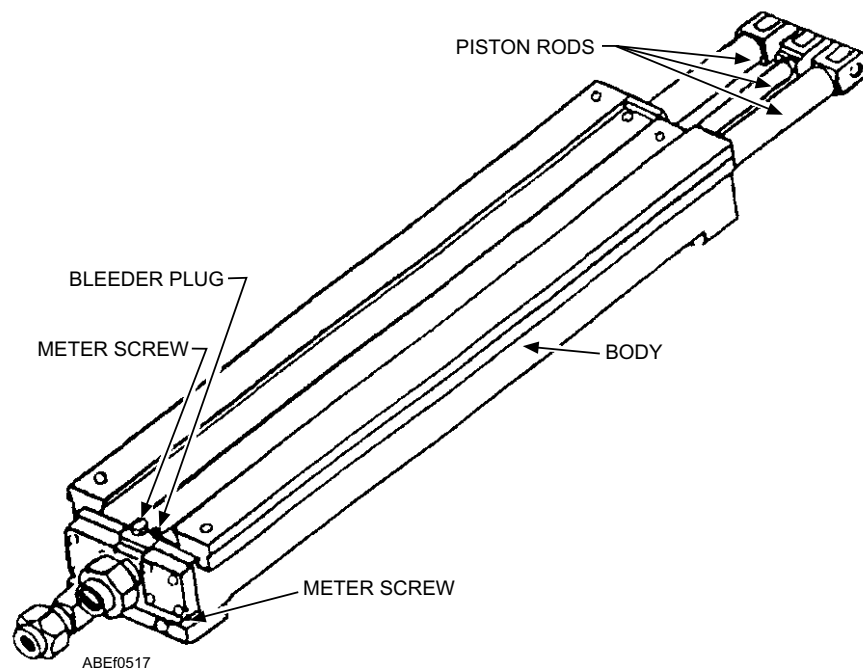
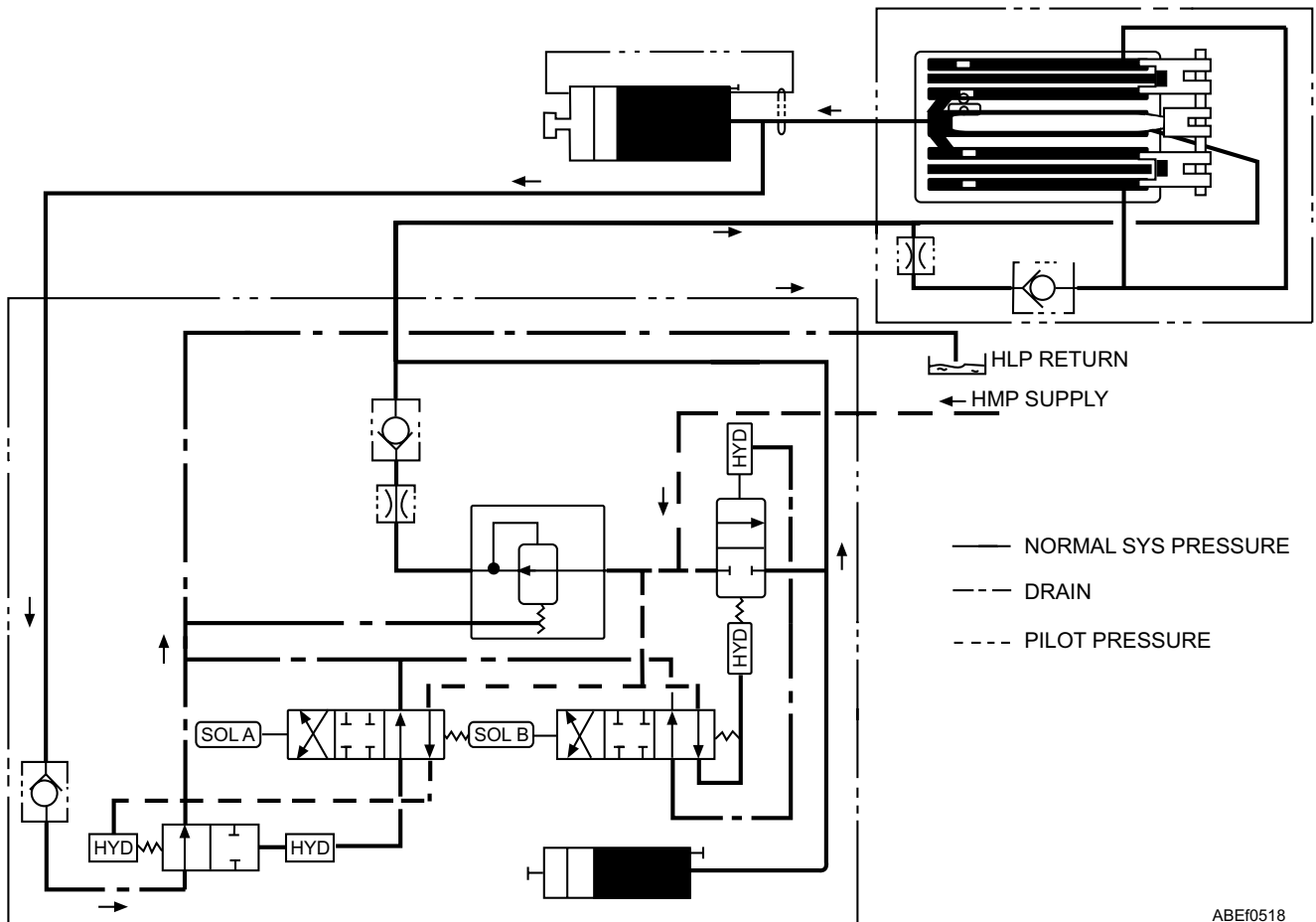

Figure 5-17.—Buffer cylinder assembly.



ABE0518

Figure 5-18.—Standby cycle.

down stream from the accumulator. Opening of the check valve permits excess fluid from the buffer cylinder to be returned to the catapult gravity tank.

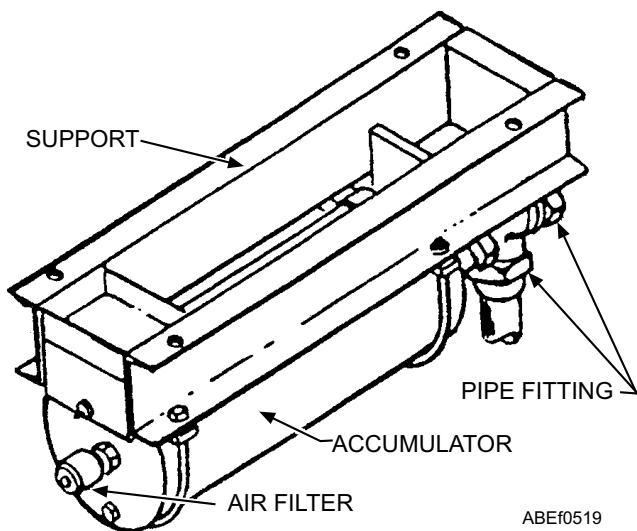

ABE0519

Figure 5-19.—Buffer accumulator assembly.

Drain Pan Assembly

The drain pan assembly (fig. 5-20) is located on the underside of the NGL assembly directly below the tensioner cylinder. The drain pan supports and protects the two quick disconnect, self sealing hydraulic

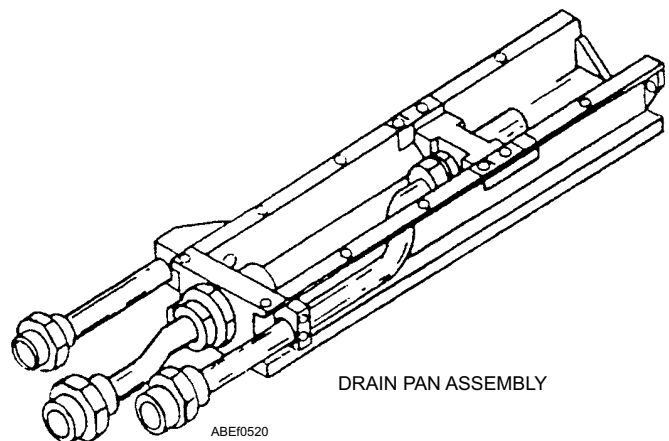

ABE0520

Figure 5-20.—Drain pan assembly.

Shock Absorber (Soft-Stop) Assembly

The shock absorber assembly (fig. 5-21) is mounted horizontally at the forward end of the NGL assembly. During the catapult retract cycle, the shock absorber provides uniform deceleration of the shuttle to bring it to a smooth, soft stop, eliminating impact forces that could cause damage to the grab assembly or the NGL assembly. The shock absorber is a compact, self-contained, sealed unit consisting of an all steel body with an inner pressure chamber and an all steel chrome-plated piston rod that requires no maintenance or adjustments.

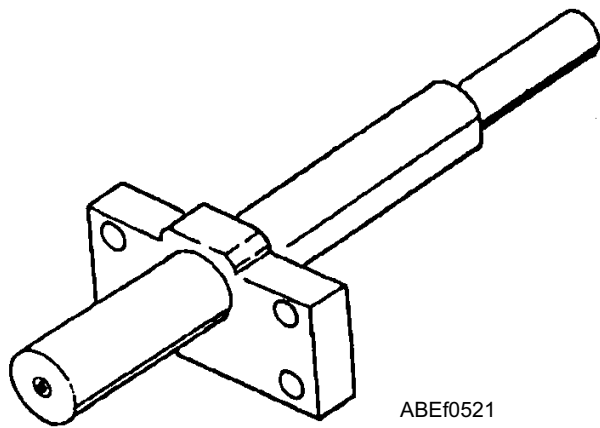

ABEf0521

Figure 5-21.—Shock absorber assembly.

coupling which connects the tensioner cylinder to the catapult hydraulic system. The drain also provides a reservoir and drain for all fluids entering the track slot.

Valve Manifold Assembly

The valve manifold assembly (fig. 5-22) controls the flow of fluid from the catapult hydraulic system to the buffer cylinder assembly. The valve manifold assembly is located below decks and consists of a support structure, two two-way flow control valves, two four-way solenoid control valves, a reducing valve, a piston-type accumulator, a terminal box to house electrical connections, and associated piping.

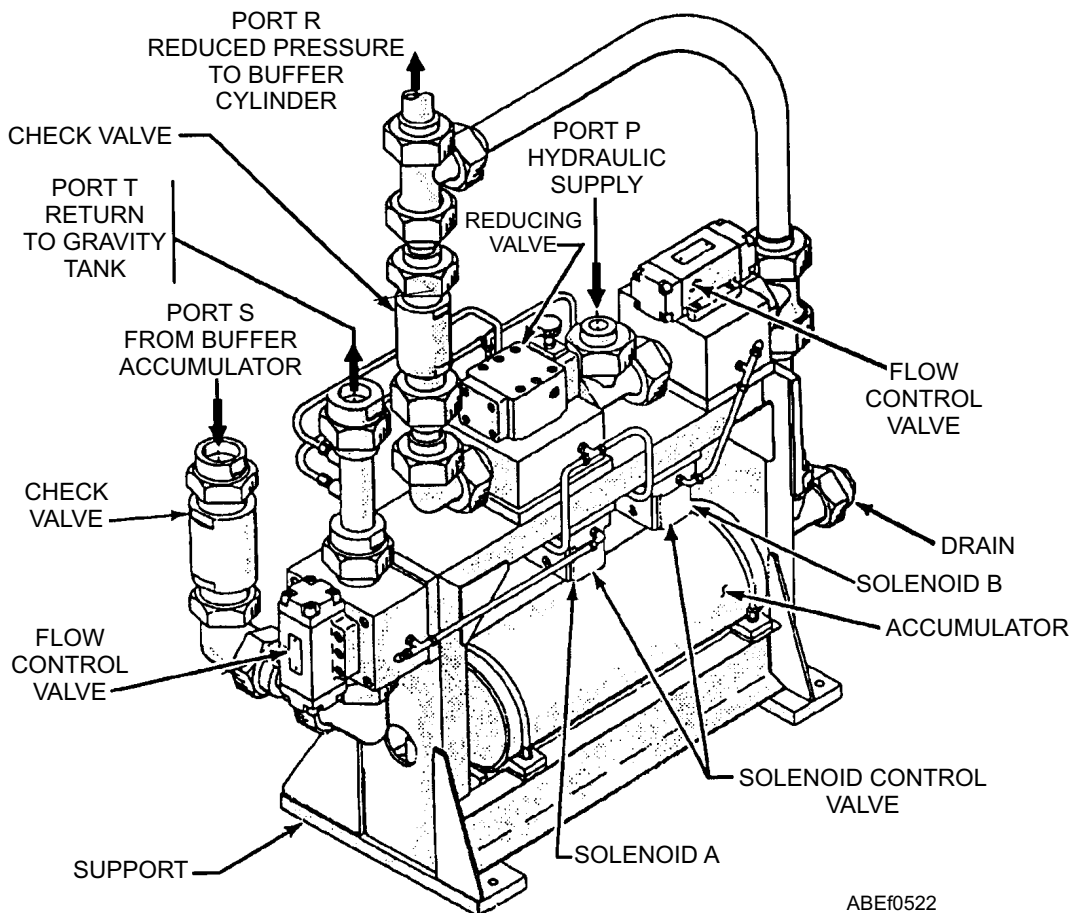

ABEf0522

Figure 5-22.—Valve manifold assembly.

NOSE-GEAR-LAUNCH CONTROL SYSTEM

On ICCS ships the operation of the NGL equipment is automatic under normal operating conditions. The only controls provided are the buffer fwd and the buffer aft push buttons installed on the monitor control console, deckedge, and the central charging panel (CCP).

On non-ICCS ships, the operation of the NGL equipment is automatic under normal operating conditions. Two control panels (fig. 5-23) are provided for the operation of the NGL system. One panel is located adjacent to the catapult deckedge station for use during normal operations. A second panel is located in close proximity to the aft end of the catapult trough for emergency operations. The control panels are identical and houses a relay, terminal board, power on indicator light, buffer fwd and buffer aft switches with integral indicator lights and associated wiring. Panel selection is made by rotating a transfer switch (fig. 5-24) from its normal position to its emergency position.

OPERATIONS

Buffer Forward

The buffer forward push button is used during an aircraft launch abort operation to move the buffer hook forward of the holdback bar so that the release element and holdback bar can be removed from the aircraft.

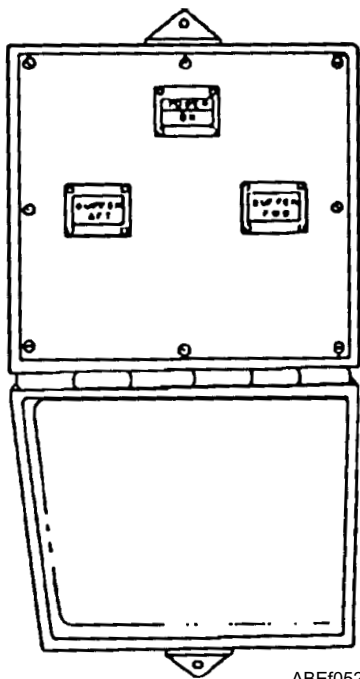

Figure 5-23.—Deckedge and emergency control panel.

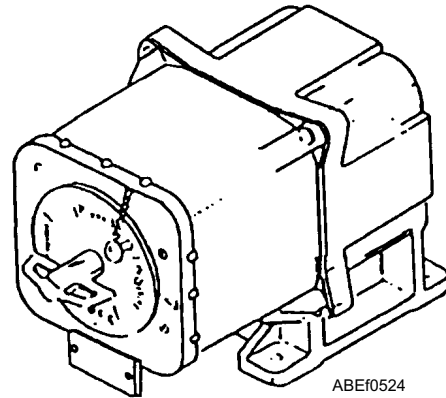

Figure 5-24.—Transfer switch.

When the BUFFER FWD push button is pressed, the buffer forward solenoid (A) is energized (fig. 5-25), shifting the buffer forward solenoid valve, allowing medium-pressure hydraulic fluid to shift the piston of the flow control valve. When the piston of the flow control valve shifts, fluid flow from the aft end of the buffer cylinder assembly to the gravity tank is shut off. This causes a pressure buildup on the aft end of the buffer cylinder assembly pistons. Since the area on the aft side of the pistons is larger than the area on the forward side, the pistons, piston rods, and attached slide assembly are driven forward.

Buffer Aft

The buffer aft push button is pressed during an abort operation when the aircraft holdback bar is connected to the buffer hook; the fluid pressure acting on the forward side of the buffer pistons will tow the aircraft aft. When the buffer has moved back 4 to 10 inches, the abort force is reduced because hydraulic pressure is bled off through exposed holes in the buffer-cylinder assembly orifice tubes. Aircraft braking is required prior to releasing the push button to hold the aircraft against its thrust load. When the NGL BUFFER AFT push button is pressed after the aircraft is removed from the catapult and the buffer hook is forward, hydraulic fluid pressure will return the pistons, piston rods, and slide assembly fully aft. When the slide assembly is retracted, the buffer hook returns to a position below deck.

When the BUFFER AFT pushbutton is pressed, the buffer aft solenoid (B) is energized (fig. 5-26), shifting the buffer aft solenoid valve, allowing medium-pressure hydraulic fluid to shift the piston of the flow control valve. Medium-pressure hydraulic fluid flows through the flow control valve to the buffer cylinder

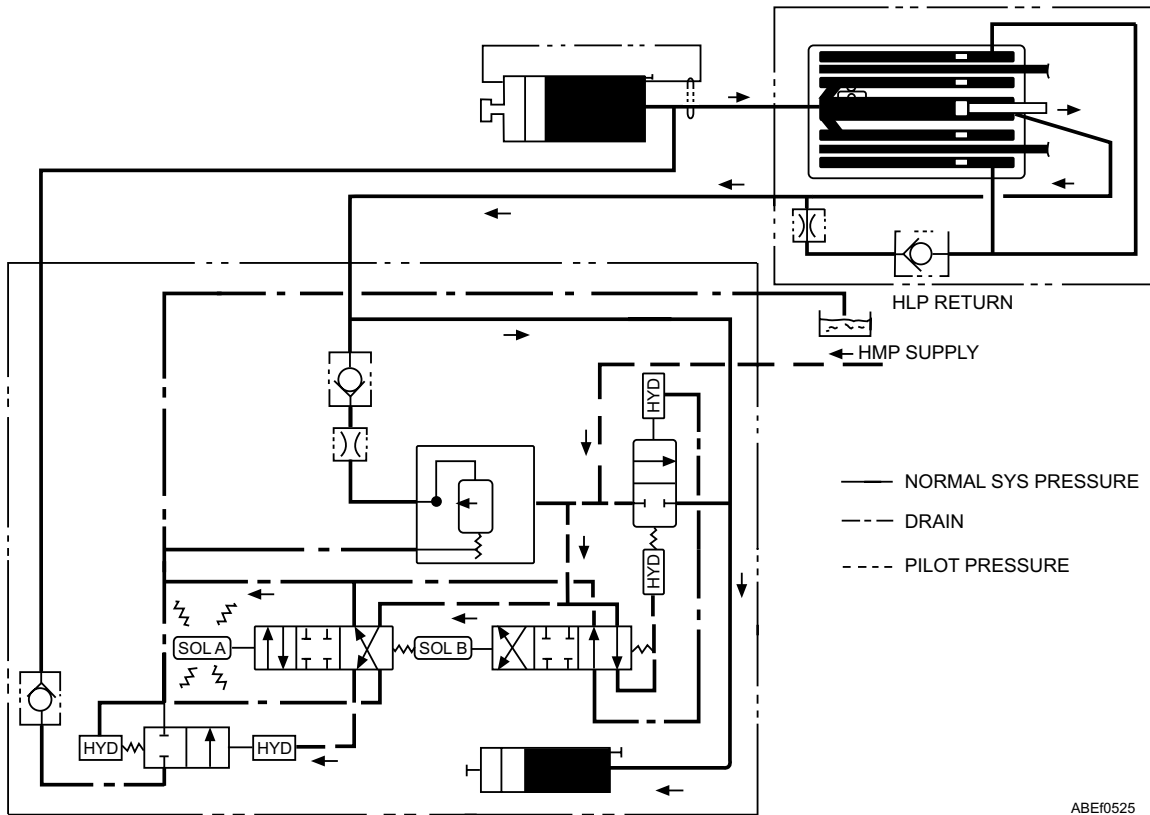

Figure 5-25.—Abort aircraft-buffing forward cycle.

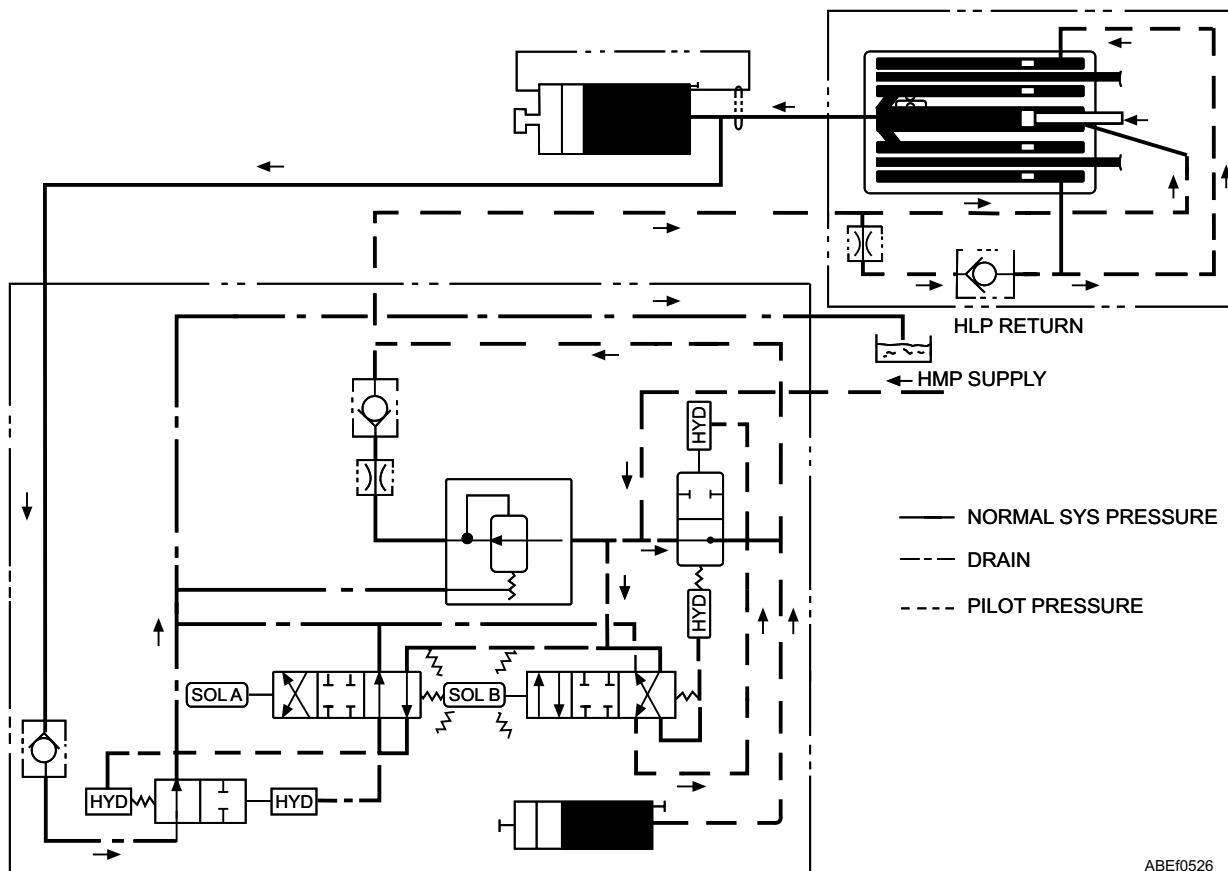

Figure 5-26.—Abort aircraft-buffing aft cycle.

assembly. Fluid pressure is applied to the forward side of the buffer pistons; and the pistons, piston rods, and slide assembly move aft. As the pistons move aft, fluid is forced out of the aft end of the buffer cylinder assembly, through a check valve and the other flow control valve, to the gravity tank.

REVIEW QUESTIONS

- Q12. List the NGL guide tracks.*
- Q13. The slide is mechanically connected to what component?*
- Q14. What component resets the buffer hooks?*
- Q15. What ensures the launch bar makes contacts with the buffer hook actuator roller?*

- Q16. The orifice tube is located in which cylinder of the buffer cylinder assembly?*
- Q17. The void created as the piston rods move forward is filled with hydraulic fluid from what assembly?*
- Q18. On ICCS ships, the buffer fwd and buffer aft pushbuttons are installed on what control panels?*

SUMMARY

In this chapter we have discussed the functions and operating procedures for the JBDs and Mk 2 NGL equipment. For additional, in-depth descriptions of this equipment, see the applicable NAVAIR technical manuals.

CHAPTER 6

THE AIRCRAFT LAUNCH AND RECOVERY EQUIPMENT MAINTENANCE PROGRAM (ALREMP)

As an ABE, you will find that most of your duties will be performing preventive maintenance, or the supervision of maintenance, on catapults, arresting gear, visual landing aid (VLA) and their associated equipment. At times you may also be assigned to one of the support branches of V-2 division, such as maintenance control, maintenance support, or material control. Regardless of your assignment and specific duties, you will need a working knowledge of the Aircraft Launch and Recovery Equipment Maintenance Program (ALREMP).

The primary objective of the ALREMP is to achieve and sustain maximum operational readiness of aircraft launch and recovery equipment in support of carrier flight operations and to achieve and maintain a zero maintenance error rate through the use of standardized procedures, a dynamic quality assurance program, and analytical review of maintenance documentation and records.

MAINTENANCE, LEVELS, RESPONSIBILITIES, AND TYPES

LEARNING OBJECTIVES: Identify organizational, intermediate, and depot level maintenance. Identify the maintenance concepts peculiar to each of the three levels of maintenance. Recognize upkeep and overhaul maintenance.

The term maintenance has a very general meaning. It could mean maintenance that can be performed in minutes at the work center, or organizational level, or it could mean maintenance that requires months of overhaul in an industrial-type facility at the depot level. We need more than the word maintenance to indicate that a specific type of maintenance must be accomplished.

MAINTENANCE LEVELS

All aircraft launch and recovery equipment (ALRE) maintenance functions are divided into one of three distinct maintenance levels: organizational, intermediate, or depot. To determine at which level

maintenance tasks must be accomplished, you must refer to the appropriate technical manual. Maintenance tasks are assigned according to the complexity, scope, and range of the work to be performed. This allows maintenance to be performed at the lowest practical level in order to maintain required readiness and material condition. The three levels of maintenance are explained in the following paragraphs.

Organizational Maintenance

Organizational or O-level maintenance is the maintenance that is normally done by the catapult and arresting gear crews. In some cases organizational maintenance may be done by intermediate or depot activities. O-level maintenance tasks are grouped under the following categories:

- Inspection, operation, and servicing as defined and required by PMS
- Corrective and preventive maintenance, including on-equipment repair and removal/replacement of defective parts
- Incorporation of technical directives (TDs) within prescribed limitations
- Record keeping and report writing

Intermediate Maintenance

Intermediate or I-level maintenance is done by designated maintenance activities in support of fleet units. The aircraft intermediate maintenance department (AIMD) on aircraft carriers is an example of such activities. I-level maintenance includes the following functions and services:

- Repair, test, inspection, and modification of ALRE components and related equipment
- Manufacture of selected and nonavailable parts
- Incorporation of technical directives within prescribed limitations
- Calibration of designated equipment

Depot Maintenance

Depot or D-level maintenance is maintenance that requires skills and facilities beyond the O- and I-levels of maintenance. It is performed by naval shipyards, commercial shipyards, Naval Ship Repair Facilities, contractor repair, the Naval Air Warfare Center (NAWC), and by voyage repair teams (VRTs) from specified naval aviation depots. D-level maintenance supports the lower I- and O-levels of maintenance by providing engineering assistance and performing maintenance beyond the capability of lower level maintenance activities. D-level maintenance functions are grouped as follows:

- Major overhaul and repair to ALRE
- Modernization, modification, or conversion of system components
- Calibration (type III) by Navy Calibration Laboratories
- Incorporation of TDs and service changes
- Manufacture of parts and/or accessory items
- Technical and engineering assistance

MAINTENANCE TYPES

There are two general types of ALRE maintenance performed without distinction as to levels of maintenance. They are upkeep and overhaul.

Upkeep Maintenance

Upkeep maintenance is preventive, corrective, or additive maintenance performed by catapult and arresting gear crewmembers. It includes servicing, periodic inspection, functional and bench testing, replacement, preservation, and repair of catapult and arresting gear equipment.

Overhaul Maintenance

Overhaul maintenance is the process of disassembly sufficient to inspect all the operating components. It includes the repair, replacement, or servicing as necessary followed by reassembly and functional testing. Upon completion of the overhaul process the equipment will be capable of performing its intended service. Much of this work is normally done at naval overhaul and depot facilities, contractor plants, and other industrial facilities.

REVIEW QUESTIONS

- Q1. List the three levels of maintenance.*
- Q2. What is the concept of each level of maintenance?*
- Q3. What are the general types of maintenance?*

V-2 MAINTENANCE ORGANIZATION STRUCTURE AND RESPONSIBILITY

LEARNING OBJECTIVES: Describe the duties of maintenance control, quality assurance, and maintenance support branches of V-2 division. Describe the procedures used to complete the ALRE maintenance action form (MAF). Describe the operation of the visual information display system (VIDS) board.

Aircraft launch and recovery equipment (ALRE) includes catapults, arresting gear and visual landing aids (VLA). Since ALRE is utilized by high performance aircraft, safety must always be paramount to the personnel who operate and maintain the equipment. A properly implemented maintenance program will improve safety, maintenance integrity, performance, training of personnel, management, and evaluation of maintenance performed. The aircraft launch and recovery maintenance program (ALREMP) is designed to maximize the effective utilization of manpower and material to accomplish this goal.

The ALREMP provides standard maintenance organization and procedures to be used by all V-2 divisions. This standardization relies heavily on the maintenance control (MC), quality assurance (QA), and maintenance support (MS) branches of the division to establish good management practices and prevention of maintenance defects. Figure 6-1 depicts the ALRE maintenance organizations for aircraft carriers. You will notice that in each of the divisions illustrated, three distinct types of organization are identified. They are (1) the operational organization, which depicts the lines of authority delegated in the daily functions of a V-2 division; (2) the maintenance group, which includes the lines of authority to be observed by all personnel involved in the actual performance of any maintenance action; and (3) the maintenance organization.

The maintenance organization has the responsibility of managing the maintenance effort. This includes the planning and performance of maintenance, compliance with all maintenance policies and technical directives, continued training of all maintenance

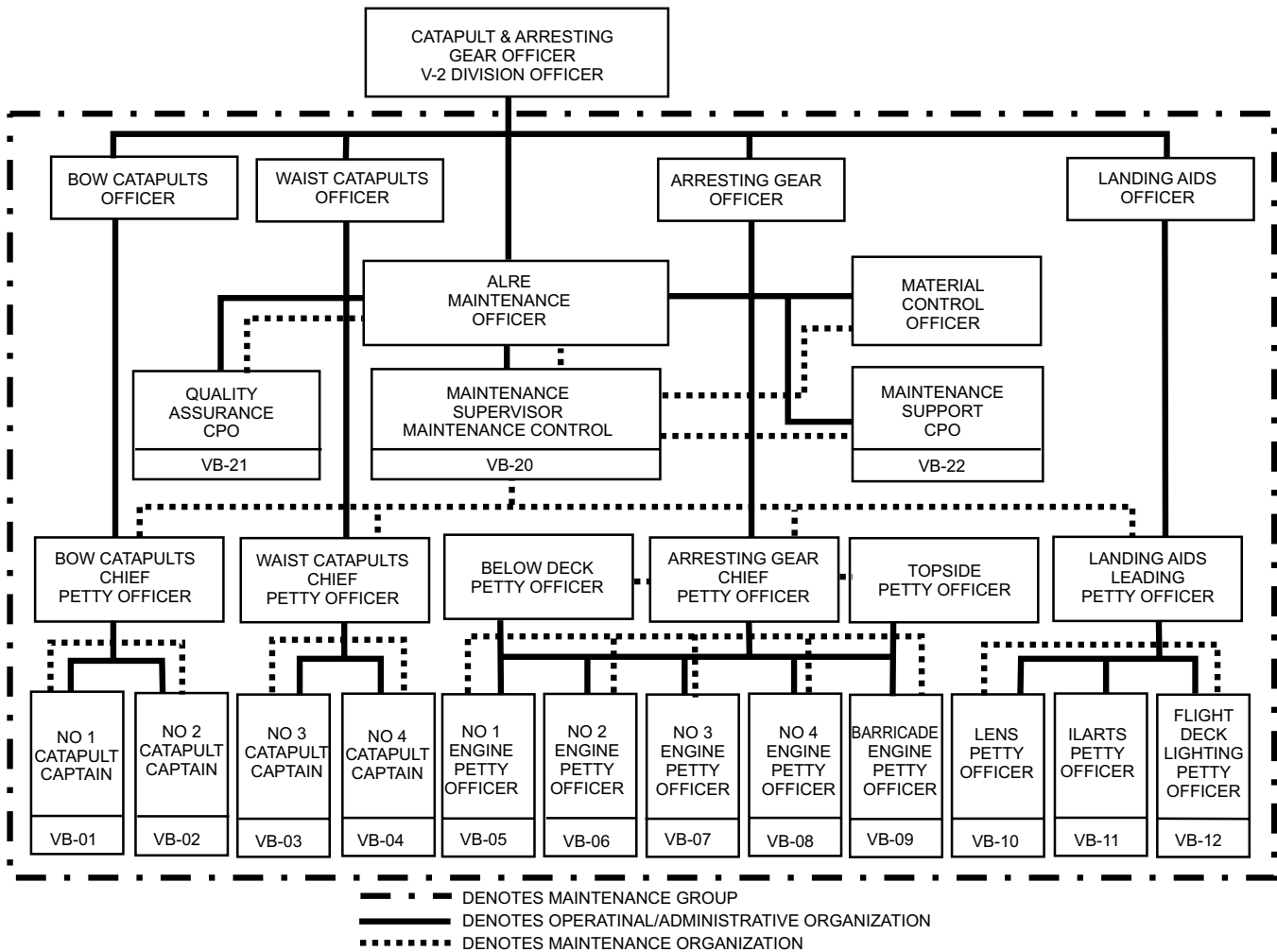

ABE601

Figure 6-1.—ALRE maintenance organization (CV/CVN).

personnel, maintenance administration, and verification of actual maintenance performance.

MAINTENANCE CONTROL (MC)

Maintenance control is the nerve center of V-2 division's maintenance effort. It is the center of all maintenance activity, directing and receiving up-to-date information in order to properly assess courses of action to be taken when any maintenance action is performed. In every situation the maintenance officer, assisted by the maintenance control chief, will be the controlling agent, acting as the event manager in all maintenance actions. Only the ALRE maintenance officer or the maintenance control chief has the authority to certify that maintenance actions have been completed and that equipment can be returned to an operational status.

The maintenance officer, with the assistance of the maintenance control chief, is specifically responsible for the following:

- Upkeep maintenance performed on a day-to-day basis, including scheduled and unscheduled maintenance, on-equipment repair, and the removal/replacement of defective parts and components
- Incorporation of TDs, service changes (SCs), interim rapid action changes (IRACs), rapid action changes (RACs), service bulletins, and repair procedures
- Documentation of all maintenance actions
- Administration of the Maintenance Data System (MDS)

- Maintenance of an active QA program to include the inspection of all critical areas of each maintenance action performed, the availability of qualified quality assurance inspectors (QAIs), work center collateral duty inspectors (CDIs), and when necessary, collateral duty quality assurance inspectors (CDQAIs), and the operation and maintenance of an ALRE technical publications library (TPL) to support all equipment and maintenance in the division
- Ensuring liaison and coordination with and documentation of maintenance from shore intermediate maintenance activities (SIMAs), VRTs, naval shipyards (NSYs), and local maintenance support activities
- Planning and submitting budget requests for the funding of tools, spare parts, and materials necessary for the proper operation and maintenance of ALRE
- Maintaining OPTAR expenditure logs and records
- Requisitioning parts and materials to support ALRE operations and maintenance
- Establishing and maintaining an effective tool control program
- Being knowledgeable of procedures for ordering repair parts, from initial identification through material receipt.
- Being knowledgeable of operating space item (OSI) operations and listings. (Stocking of OSIs is a Supply Department function, but inputs for stocking originate with the work center.)
- Maintaining strict tool control accountability within the work center.
- Recommending qualified and responsible personnel to be CDIs for the work center.
- Ensuring that QAIs/CDQAIs or CDIs are available for all tasks requiring QA inspection.
- Assisting the QA Branch in implementing and maintaining support for the division safety program by conducting safety training in the work center, using and promoting practices to enhance safety, and reporting all accidents and unsafe practices, procedures, or conditions.
- Assisting work center branch officers in maintaining the training program by ensuring optimum use of personnel through job assignments based on prior training and experience, that formal in-service training is conducted, that on-the-job training (OJT) is conducted under the supervision of qualified work center personnel, and that Personnel Qualification Standards are administered according to established procedures.
- Maintaining required reading files and ensuring that all assigned work center personnel read and initial the information contained in them on a monthly basis.
- Ensuring that all work center required publications are available and maintained with current changes.

All personnel in the maintenance organization are subordinate and responsible to the maintenance officer. As work center group supervisors and work center supervisors, they are responsible for the maintenance of all systems and equipment assigned to their work centers. Both the group and the work center supervisors direct and manage the maintenance program in their work centers, supervise the day-to-day ALRE operations, ensure proper documentation of preventive and corrective maintenance, and maintain effective communications between the work centers and MC to ensure an up-to-date maintenance profile of the division. They also direct assigned work center personnel in the performance of their duties and the daily operation of ALRE. Group and work center supervisors are also responsible for the following:

- Keeping MC informed of all problems and equipment status in the work center.
- Updating and validating information on the Visual Information Display System (VIDS) board with MC daily.
- Ensuring that all maintenance documentation is complete and correct.

VISUAL INFORMATION DISPLAY SYSTEM (VIDS)

The division overall maintenance status is provided by a visual display of current maintenance information, located in maintenance control and maintained by the maintenance control chief, through the use of the visual information display system (VIDS) and the maintenance requirement (MR) status boards. These are important management tools in the maintenance

program because they provide a graphic display of vital up-to-date information.

The VIDS board displays all maintenance status information—particularly system problems or failures and supply status—providing the ability to review the overall maintenance situation quickly. This allows the

maintenance officer, maintenance control chief, and group and work center supervisors to carry out their duties more effectively and efficiently.

The maintenance control VIDS board (fig. 6-2) displays maintenance information from all work centers in the division. It and the work center VIDS

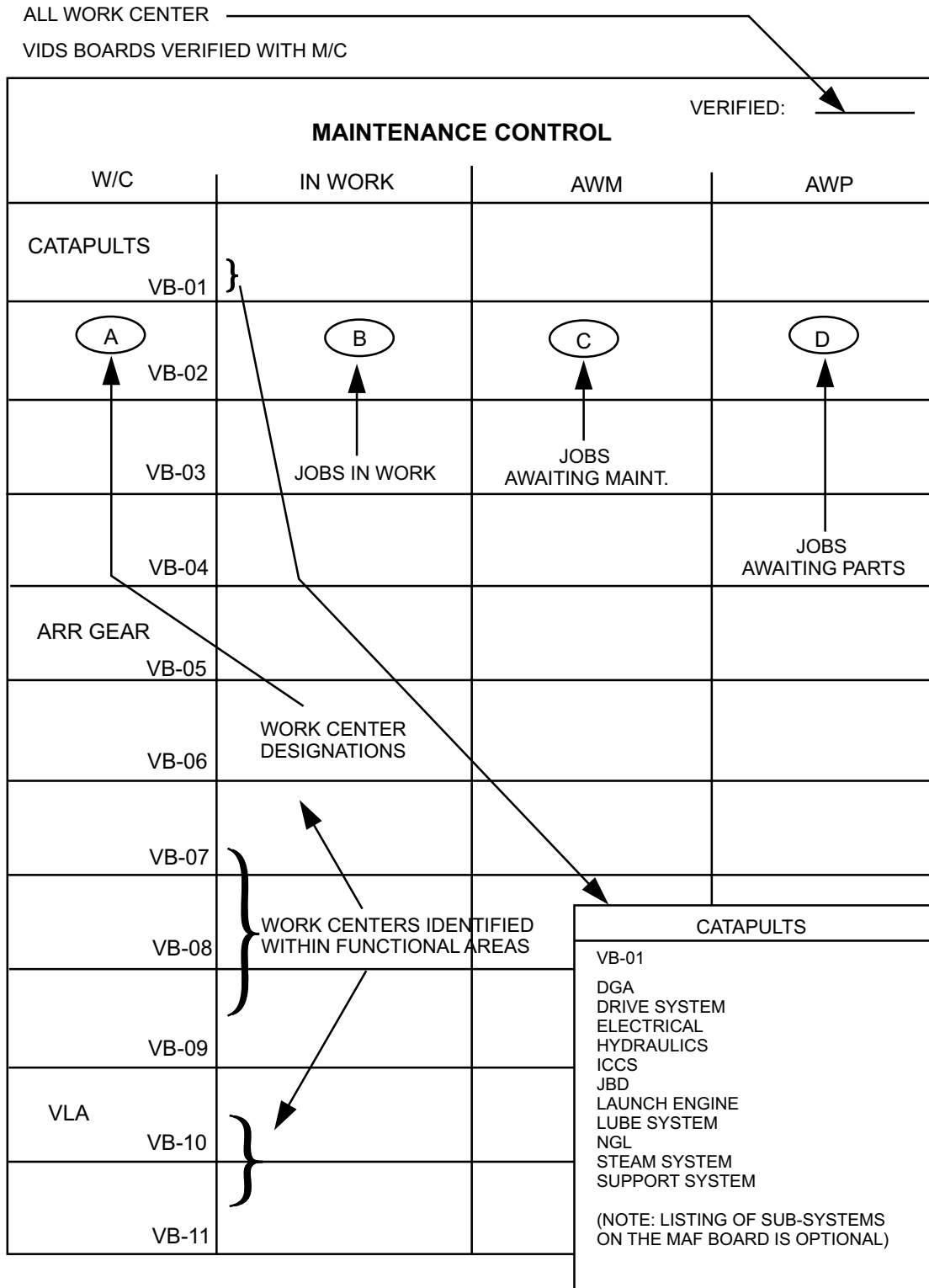

Figure 6-2.—Maintenance control VIDS board.

ABEF602

boards (fig. 6-3) are divided into sections representing each work center. Each work center section is identified by a standard work center designation, identification of the work center systems within the work center maintenance areas are optional on the maintenance control VIDS board. Four columns are mandatory on the maintenance control and all work center boards. They are (1) the column displaying the work center

designation, as already mentioned; (2) the In-Work column, which is used to display in-progress maintenance actions; (3) the AWM or Awaiting Maintenance column, to display maintenance actions that have been deferred; and (4), the AWP or Awaiting Parts column, to display maintenance actions that cannot be completed because of a lack of parts or material.

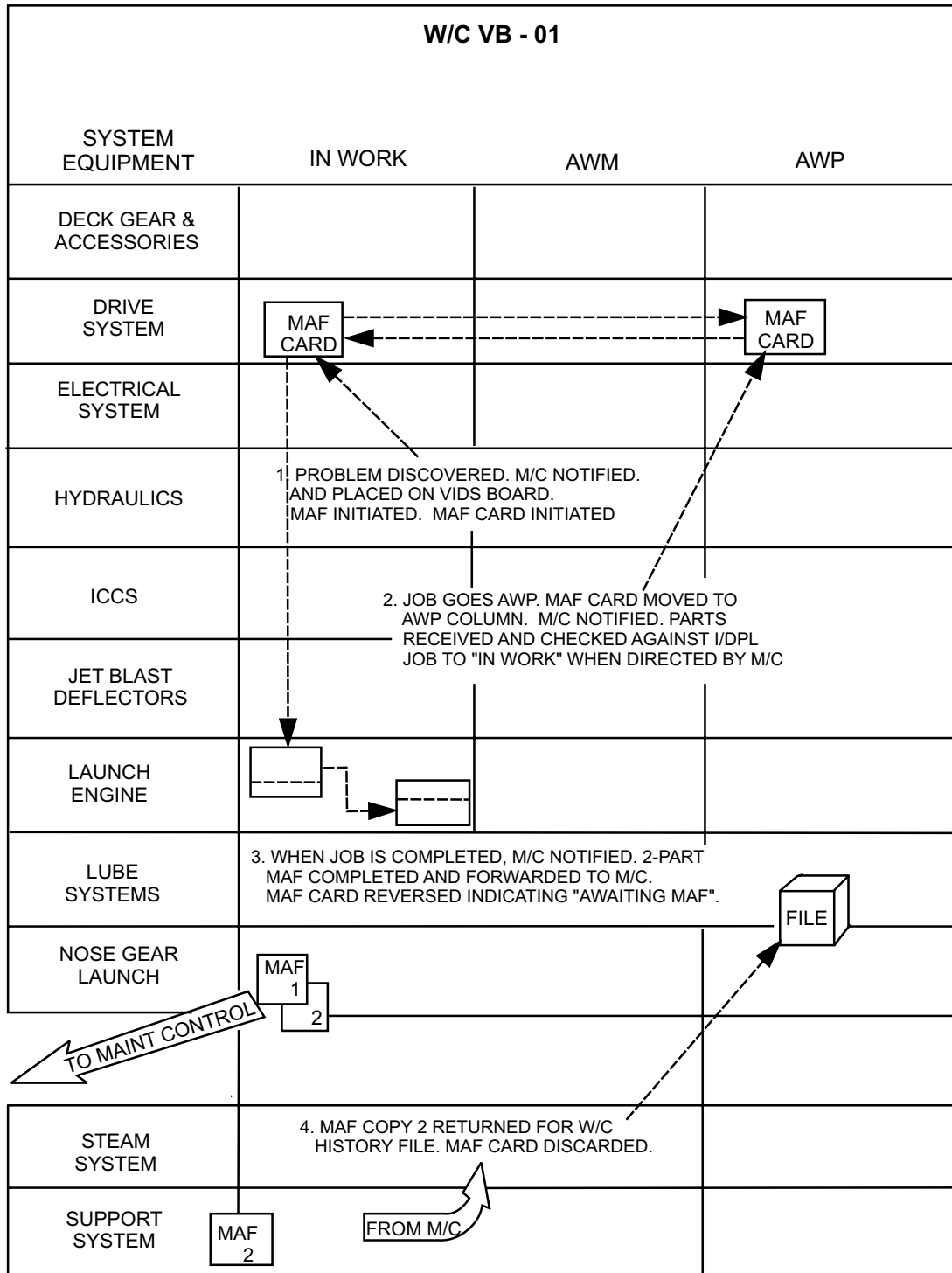

Figure 6-3.—Work center VIDS board.

ABEf603

Aircraft Launch and Recovery Equipment (ALRE) Maintenance Action Form (MAF) Cards

ALRE MAF cards (fig. 6-4) are used on the VIDS boards to track all outstanding work center maintenance actions, both on the work center and maintenance control VIDS boards. Before any maintenance action is started, the responsible work center must notify maintenance control. At this time, work center and maintenance control MAF cards are initiated, each card will reflect identical information consisting of a job control number (JCN) and a brief description of the maintenance action to be performed; the work center also initiates a MAF at this time. The PRIORITY section of the card will also be color coded, as required, to indicate the system and maintenance status concerning equipment operational capability. These color codes are standardized as follows:

Blue is used in the LIM block to indicate limited capability.

Red is used in the DN block to indicate that the equipment is out of commission.

No Color is used or required if maintenance is routine and does not affect equipment operability.

Black is used when a maintenance action has been completed and inspected at the proper level and only a functional check remains to return the equipment to service; a black line is drawn across all four blocks of the PRIORITY section.

Similarly, the MS and QA blocks are provided on the MAF card to indicate requirements for maintenance support augmentation of the work center and/or QAI/CDQAI (not CDI) level inspection of the job. Jobs requiring QAI/CDQAI (not CDI) inspection will be reflected with a MAF card on the quality assurance (QA) VIDS board and job requiring maintenance support (MS) participation will be reflected on the MS VIDS board.

The MAF card is then placed in the appropriate columns of the maintenance control, quality assurance, maintenance support, and work center VIDS boards, to indicate the maintenance action's current status: in-work, awaiting maintenance, or awaiting parts. Upon completion of the maintenance action, the MAF card is inverted to indicate that maintenance control is now awaiting a completed MAF from the responsible work center.

AWAITING MAF				NSR		M/C	
		JULIAN DATE		JCN			
JCN		JULIAN DATE	DISCREPANCY/PMS	PRIORITY			
W/C	JSN		MRG _____	QA	MS	DN	LIM

The MAF Card is locally produced and is used to monitor and manage the workload. Outstanding maintenance actions will be indicated by a MAF Card on both the M/C and w/c VIDS boards, as well as in QA and MS, when applicable. When the job is completed and reported to M/C, the MAF Card is simply reversed on the board to indicate "AWAITING MAF" until the 2-part MAF is completed, delivered to M/C, and signed off by the maintenance officer/maintenance control supervisor. M/C then discards the MAF Card and the w/c discards it upon receipt of the copy 2 MAF from M/C. QA will discard its MAF Card upon receipt of MAF copy 1. MS discards its MAF Card upon job completion and transfer of manhours to summary sheet.

NOTE: The large, unused central portion of the front of the MAF Card may be modified locally to help track supply data, manhours, work start/stop, etc, If desired.

ABE604

Figure 6-4.—ALRE MAF card.

Aircraft Launch and Recovery Equipment (ALRE) Maintenance Action Form (MAF)

The ALRE MAF (fig. 6-5) is the major divisional record of all maintenance performed and provides historical data for future references. The ALRE MAF also supplements the OPNAV 4790/2K, Ship's

Maintenance Action Form, used in support of the Current Ships' Maintenance Project (CSMP). All equipment inspections and maintenance actions (scheduled/unscheduled and corrective maintenance) are documented on the ALRE MAF.

The ALRE MAF (see fig. 6-5) is divided into seven areas as follows:

AIRCRAFT LAUNCH AND RECOVERY EQUIPMENT (ALRE) MAINTENANCE ACTION FORM (FOR SNAP I OMMS)

SECTION I INFORMATION											
1. SHIPS UIC	2. W/C	3. JSN	4. APL/AEL	5. EQUIPMENT NOUN NAME			6. WND	7. STAT	8. CAS	9. DFR	10.
11.	12.	13. IDENT/EQUIPMENT SERIAL NUMBER		14. EIC	15. SAFETY HAZARD	16. LOCATION		17. WND DATE			
18. ALTERATIONS (SERVICE CHANGE - SHIPALT)				19. *I*	20. INSURV NUMBER	21. SUFFIX	22. U	23. S	24. P/F		
SECTION II DEFERRAL ACTION				25. S/F MHRS EXP.	26. DEFER DATE	27. S/F MHRS REM	28. DEADLINE DATE				
SECTION III COMPLETED ACTION				29. ACTION TKN	30. S/F MHRS	31. COMPLETION DATE	32. ACT MAINT TIME	33. TI	34. METER READING		
	DATE	TIME	DATE	TIME	DATE	TIME	DATE	TIME	DATE	TIME	
START											
STOP											
SECTION IV REMARKS/DESCRIPTION											
35. REMARKS/DESCRIPTION										36. CONT. SHEET	
37. CSMP SUMMARY											
38. FIRST CONTACT/MAINT MAN (PRINT/SIGN)			39. RATE	40. SECOND CONTACT/SUPERVISOR (PRINT/SIGN)			41. PRI	42. T/A	43. INTEGR. PRI	44. IUC	45. TYCOM
ADDITIONAL ALREMP INFORMATION											
SUBMIT 4790/CK?		P/C/O	ALRE MALF CODES			CORROSION CODES		SAFETY TAG INFORMATION		RED TAG SER. NO.	SHOT/HIT/LA
YES	NO		WND	EXT DAMAGE	TYPE MALF	TYPE	ACT. TKN.	SAFETY TAGS REQUIRED?			
<input type="checkbox"/>	<input type="checkbox"/>							YES	NO	IF YES, HOW MANY?	
								<input type="checkbox"/>	<input type="checkbox"/>		
COMPONENT PART NUMBER						MIP CONTROL NO. (MIP#)			MRC CODE		
Q A	1ST QA INSP. BY (PRINT/SIGN)			2ND QA INSP. BY (PRINT/SIGN)			FINAL QA INSP. BY (PRINT/SIGN)		V-2 MAINT. OFFICER (PRINT/SIGN)		
MATERIAL CONTROL			VIDS/MAF JCN:				VIDS/MAF JCN:				
QTY	NOMENCLATURE		PART NUMBER			CONTRACT NUMBER		ALRE TOOL CONTROL			
								ARE ALL TOOLS ACCOUNTED FOR?			
								YES <input type="checkbox"/> NO <input type="checkbox"/>			
								W/C TOOL PO (PRINT/SIGN)			
								YES <input type="checkbox"/> NO <input type="checkbox"/>			
								CENTRAL TOOL PO (PRINT/SIGN)			
								NOTE: A LOST/MISSING/BROKEN TOOL REPORT MUST ACCOMPANY THIS MAF IF THE "NO" BLOCK IS CHECKED			
								PAGE OF			

ABE1605

Figure 6-5.—Aircraft Launch and Recovery Equipment (ALRE) Maintenance Action Form (MAF).

1. Information: contains the job control number, consisting of the work center designation and the job sequence number (JSN), equipment configuration data, and discrepancy description codes.
2. Deferral Action: contains deferral dates and manhours expended information (total manhours expended by personnel involved in the maintenance action up to the time of deferral), manhours remaining (estimated number of manhours remaining to complete the maintenance action).
3. Completed Action: contains action taken, completion date and total manhours expended.
4. Remarks/Description: contains a narrative description of the discrepancy and the work done to correct it.
5. Additional ALREMP Information: contains ALRE specific codes, safety tag data, shot/hit/VLA data, PMS data and QA/ALRE MO signatures.
6. Material Control: contains quantity, nomenclature, part number and contract number for requisitioned items also contains two blocks for AIMD-assistance VIDS MAF JCNs.
7. ALRE Tool Control: contains lines for the work center and central tool room Petty Officers signature.

When a maintenance action is completed, the appropriate work center will complete a MAF, this will provide a comprehensive record of the maintenance action performed and establish historical data for future reference. Therefore MAFs will be retained as follows:

- Corrective maintenance action MAFs will be retained for a period of 1 year. The QA branch will retain copy 1. Copy 2 of the MAF will be retained by the maintenance responsible work center.
- Preventive maintenance action MAFs must be retained by QA and the work center for the most recent PMS action performed only.

MAINTENANCE REQUIREMENT STATUS BOARDS

Maintenance requirement (MR) status boards are tools used to track critical scheduled/situational maintenance and inspections required on catapults,

arresting gear, and VLA equipment. These requirements are based on calendar periods (daily, weekly, monthly, and so on) and the total number of catapult shots or arresting gear arrestments (hits) accumulated. Documentation of shots and hits is therefore mandatory to ensure that prescribed maintenance and inspection requirements are performed on time.

Maintenance requirement status boards (figs. 6-6 and 6-7) are locally produced or procured. As a minimum these boards will contain information on each shot- or hit-related maintenance task specified in the PMS system. The minimum information elements required are the following:

- Maintenance requirement periodicity code (M-1R, Q-1R, 24M-2R, and so forth)
- Description of the task and the frequency of requirement
- Shot or hit number that the maintenance requirement is due to be performed on
- Total number of shots or hits to date

As with the maintenance control VIDS board, the maintenance control MR status board will reflect the required maintenance tasks of each work center in the division. The maintenance control MR status board is maintained and updated only by the maintenance officer, the maintenance control chief, or a person specifically designated by the maintenance officer.

Each work center will also have a MR status board that reflects the exact information contained on the maintenance control board. The work center supervisor or his designated assistant will maintain and update the work center's MR status board.

A continuous audit and daily validations of the MR status boards between maintenance control and the work centers are required to ensure accuracy and continuity of shot/hit numbers and inspection requirements.

REVIEW QUESTIONS

- Q4. What is the nerve center of V-2 division maintenance effort?*
- Q5. What are the difference types of distinct organizations within V-2 division?*
- Q6. What are the mandatory columns required on the VIDS board?*

WORK CENTER	PMS MAINTENANCE REQUIREMENT R-2	PMS MAINTENANCE REQUIREMENT R-3	PMS MAINTENANCE REQUIREMENT R-5	PMS MAINTENANCE REQUIREMENT R-6				
V B 0 1	REPLACE DRIVE SYSTEM CABLE BETWEEN 3000/3500 SHOTS OR 24 MONTHS SERVICE	REQUEST CYLINDER SLOT MEASUREMENTS FROM TYPE COMMANDER NOTE: ACCOMPLISH THIS MR WHEN DICTATED BY TABLE 1 OF MRC	INSPECT SHUTTLE, CONNECTOR GUIDES, WATERBRAKE AND LAUNCH PISTON ASSEMBLIES FOR ALIGNMENT AFTER EVERY 2600 AND BEFORE 2800 SHOTS, REPLACE CYLINDER GAP SEALS	INSPECT AND LUBRICATE WATERBRAKE AND LAUNCH PISTON ASSEMBLIES. NOTE: ACCOMPLISH BETWEEN 1300-1400, 2500-2800, AND EVERY 500 SHOTS THEREAFTER.				
	24 MONTHS CABLE REPLACEMENT							
	DATE OF LAST MR	REPLACEMENT DATE MR	DATE OF LAST MR	REPLACEMENT DATE MR	DATE OF LAST MR	REPLACEMENT DATE MR	DATE OF LAST MR	REPLACEMENT DATE MR
	SHOT NO. LAST MR		SHOT NO. LAST MR		SHOT NO. LAST MR		SHOT NO. LAST MR	
	SHOT NO. DUE MR		SHOT NO. DUE MR		SHOT NO. DUE MR		SHOT NO. DUE MR	
	TOTAL SHOTS TO DATE		TOTAL SHOTS TO DATE		TOTAL SHOTS TO DATE		TOTAL SHOTS TO DATE	
	TOTAL SHOTS LEFT TO MR		TOTAL SHOTS LEFT TO MR		TOTAL SHOTS LEFT TO MR		TOTAL SHOTS LEFT TO MR	

V B 0 2	24 MONTHS CABLE REPLACEMENT							
	DATE OF LAST MR	REPLACEMENT DATE MR	DATE OF LAST MR	REPLACEMENT DATE MR	DATE OF LAST MR	REPLACEMENT DATE MR	DATE OF LAST MR	REPLACEMENT DATE MR
	SHOT NO. LAST MR		SHOT NO. LAST MR		SHOT NO. LAST MR		SHOT NO. LAST MR	
	SHOT NO. DUE MR		SHOT NO. DUE MR		SHOT NO. DUE MR		SHOT NO. DUE MR	
	TOTAL SHOTS TO DATE		TOTAL SHOTS TO DATE		TOTAL SHOTS TO DATE		TOTAL SHOTS TO DATE	
	TOTAL SHOTS LEFT TO MR		TOTAL SHOTS LEFT TO MR		TOTAL SHOTS LEFT TO MR		TOTAL SHOTS LEFT TO MR	

V B 0 3	24 MONTHS CABLE REPLACEMENT							
	DATE OF LAST MR	REPLACEMENT DATE MR	DATE OF LAST MR	REPLACEMENT DATE MR	DATE OF LAST MR	REPLACEMENT DATE MR	DATE OF LAST MR	REPLACEMENT DATE MR
	SHOT NO. LAST MR		SHOT NO. LAST MR		SHOT NO. LAST MR		SHOT NO. LAST MR	
	SHOT NO. DUE MR		SHOT NO. DUE MR		SHOT NO. DUE MR		SHOT NO. DUE MR	
	TOTAL SHOTS TO DATE		TOTAL SHOTS TO DATE		TOTAL SHOTS TO DATE		TOTAL SHOTS TO DATE	
	TOTAL SHOTS LEFT TO MR		TOTAL SHOTS LEFT TO MR		TOTAL SHOTS LEFT TO MR		TOTAL SHOTS LEFT TO MR	

V B 0 4	24 MONTHS CABLE REPLACEMENT							
	DATE OF LAST MR	REPLACEMENT DATE MR	DATE OF LAST MR	REPLACEMENT DATE MR	DATE OF LAST MR	REPLACEMENT DATE MR	DATE OF LAST MR	REPLACEMENT DATE MR
	SHOT NO. LAST MR		SHOT NO. LAST MR		SHOT NO. LAST MR		SHOT NO. LAST MR	
	SHOT NO. DUE MR		SHOT NO. DUE MR		SHOT NO. DUE MR		SHOT NO. DUE MR	
	TOTAL SHOTS TO DATE		TOTAL SHOTS TO DATE		TOTAL SHOTS TO DATE		TOTAL SHOTS TO DATE	
	TOTAL SHOTS LEFT TO MR		TOTAL SHOTS LEFT TO MR		TOTAL SHOTS LEFT TO MR		TOTAL SHOTS LEFT TO MR	

ABEF006

Figure 6-6.—Maintenance requirement status board (maintenance control).

PMS MAINTENANCE REQUIREMENT R-2	PMS MAINTENANCE REQUIREMENT R-3	PMS MAINTENANCE REQUIREMENT R-5	PMS MAINTENANCE REQUIREMENT R-6
REPLACE DRIVE SYSTEM CABLE BETWEEN 3000/3500 SHOTS OR 24 MONTHS SERVICE	REQUEST CYLINDER SLOT MEASUREMENTS FROM TYPE COMMANDER NOTE: ACCOMPLISH THIS MR WHEN DICTATED BY TABLE 1 OF MRC	INSPECT SHUTTLE, CONNECTOR GUIDES, WATERBRAKE AND LAUNCH PISTON ASSEMBLIES FOR ALIGNMENT AFTER EVERY 2600 AND BEFORE 2800 SHOTS, REPLACE CYLINDER GAP SEALS	INSPECT AND LUBRICATE WATERBRAKE AND LAUNCH PISTON ASSEMBLIES. NOTE: ACCOMPLISH BETWEEN 1300-1400, 2500-2800, AND EVERY 500 SHOTS THEREAFTER.
24 MONTHS CABLE REPLACEMENT			
DATE OF LAST MR REPLACEMENT DATE MR	DATE OF LAST MR REPLACEMENT DATE MR	DATE OF LAST MR REPLACEMENT DATE MR	DATE OF LAST MR SHOT INSPECTION INTERVAL
SHOT NO. LAST MR	SHOT NO. LAST MR	SHOT NO. LAST MR	SHOT NO. LAST MR
SHOT NO. DUE MR	SHOT NO. DUE MR	SHOT NO. DUE MR	SHOT NO. DUE MR
TOTAL SHOTS TO DATE	TOTAL SHOTS TO DATE	TOTAL SHOTS TO DATE	TOTAL SHOTS TO DATE
TOTAL SHOTS LEFT TO MR	TOTAL SHOTS LEFT TO MR	TOTAL SHOTS LEFT TO MR	TOTAL SHOTS LEFT TO MR
PMS MAINTENANCE REQUIREMENT R-7	PMS MAINTENANCE REQUIREMENT R-11	PMS MAINTENANCE REQUIREMENT R-13	PMS MAINTENANCE REQUIREMENT R-15
IN-PLACE SHUTTLE INSPECTION. INSPECT, LUBRICATE & TEST COMPONENTS IN CATAPULT TROUGH. NOTE: ACCOMPLISH AFTER EVERY 400 AND BEFORE 500 SHOTS.	INSPECT TRAVERSE CARRIAGE SLIPPERS FOR WEAR & SECURITY. NOTE: ACCOMPLISH AFTER EVERY 3000 AND BEFORE 3500 SHOTS.	CLEAN & INSPECT RETRACTION ENGINE HYDRAULIC PIPING STRAINERS & ORIFICES. NOTE: ACCOMPLISH AFTER EVERY 2000 AND BEFORE 2200 SHOTS.	1. LUBRICATE COMPONENTS OF ROTARY RETRACTION ENGINE ASSEMBLY. 2. LUBRICATE ALL RETRACTION ENGINE AND FAIRLEAD SHEAVES. NOTE: ACCOMPLISH AFTER EVERY 100 AND BEFORE 200 SHOTS.
DATE OF LAST MR	DATE OF LAST MR	DATE OF LAST MR	DATE OF LAST MR
SHOT NO. LAST MR	SHOT NO. LAST MR	SHOT NO. LAST MR	SHOT NO. LAST MR
SHOT NO. DUE MR	SHOT NO. DUE MR	SHOT NO. DUE MR	SHOT NO. DUE MR
TOTAL SHOTS TO DATE	TOTAL SHOTS TO DATE	TOTAL SHOTS TO DATE	TOTAL SHOTS TO DATE
TOTAL SHOTS LEFT TO MR	TOTAL SHOTS LEFT TO MR	TOTAL SHOTS LEFT TO MR	TOTAL SHOTS LEFT TO MR

Figure 6-7.—Maintenance requirement status board (catapult).

- Q7. *What is used to track all outstanding maintenance actions?*
- Q8. *How is the priority section of the ALRE MAF card annotated?*
- Q9. *The ALRE MAF is divided into how many areas?*
- Q10. *What copy of the ALRE MAF is retained by QA?*

ALRE MAINTENANCE SUPPORT

LEARNING OBJECTIVE: Describe the role of maintenance support pertaining to maintenance.

The maintenance support branch is a key element in the day-to-day operation of V-2 division; it establishes a single point of maintenance expertise and capability in the division. The maintenance support branch is manned by senior, experienced ABEs and EMs (catapult/arresting gear electricians) whose training and background provide the necessary skills and knowledge to maintain ALRE equipment in a fully operational and safe status.

The primary role of the maintenance support (MS) branch is to assist cognizant operating work centers by providing technical expertise in performing maintenance or repairs on certain critical equipment. The designated critical equipment includes systems, components, assemblies, subassemblies, and parts that the failure or improper operation of can result in aircraft loss, equipment loss, or personnel injury.

Since MS personnel are assigned to assist in maintenance performed by an operating work center, the cognizant work center supervisor, who has the responsibility for the operation and upkeep of the equipment, also retains the overall responsibility for maintenance performed on the critical equipment previously mentioned.

For this reason, the cognizant operating work center must document the maintenance action on the 2-part MAF, including all maintenance support man-hours. In addition to this documentation, the MS supervisor will independently track all man-hours expended by maintenance support personnel on the MAF card placed in the maintenance support VIDS board. Following completion of the maintenance action, the MS supervisor transcribes the number of man-hours expended on a particular job and other pertinent information onto a maintenance summary

sheet, which will be retained for 2 years for local use in manpower accounting. The information on the summary sheet will include, as a minimum, the following:

- JCN
- Equipment/system name
- Description of discrepancy
- Description of corrective action
- Total number of man-hours expended

REVIEW QUESTIONS

- Q11. *What is the primary role of maintenance support?*
- Q12. *How long must the maintenance summary sheet be retained by maintenance support?*

TOOL CONTROL PROGRAM (TCP)

LEARNING OBJECTIVE: Describe some benefits of the tool control program.

The maintenance support supervisor is also responsible for the management of the division's tool control program (TCP), under the direction of the maintenance officer. The TCP was established to reduce the potential of tool-related foreign object damage (FOD) mishaps and to reduce the cost of tool replacement. This program allows you to rapidly account for all tools before, during, and after completing a maintenance task.

The TCP is based on the instant inventory concept through the use of a family of specialized tool containers. All tools have individual silhouetted locations to highlight a missing tool. An inventory list is also included in each container. On containers or tool pouches that cannot be silhouetted, an inventory list is attached, providing a means for the tool room operator and the maintenance man to inventory tools upon issue from and return to the tool room. This inventory system allows you to quickly determine that all tools have been issued to perform a specific maintenance task and all have been returned to the tool room upon completion of the maintenance. Additional benefits of the TCP are the following:

- Reduced initial outfitting and tool replacement costs
- Reduced tool pilferage

- Reduced man-hours required to complete each maintenance task
- Assurance that the proper tools are available to perform specific maintenance tasks

Detailed information concerning the ALRE TCP can be found in NAEC Miscellaneous Report 51/OR 732, the ALRE Tool Control Manual.

REVIEW QUESTIONS

Q13. List benefits of the tool control program?

QUALITY ASSURANCE (QA)

LEARNING OBJECTIVES: Describe the quality assurance branch organization. Describe the quality assurance branch responsibilities. Describe quality assurance audits.

QA is the planned and systematic pattern of actions necessary to prevent defects from occurring from the start of a maintenance operation to its finish. QA is the responsibility of all personnel involved in the operation, upkeep, and maintenance of ALRE.

The achievement of QA depends on prevention, knowledge, and special skills as they are described.

- Prevention is the power to regulate events rather than being regulated by them. This extends to the safety of personnel, the maintenance of equipment, the training of personnel, and all aspects of the total maintenance effort.
- Knowledge is derived from factual information. Knowledge is acquired through data collection and analysis as a means of identifying, tracking, and preventing defects.
- Special skills are those skills possessed by the personnel trained in the technique of data analysis and supervision of the QA program.

The QA program provides an efficient method of gathering and maintaining information on the quality, characteristics of repair parts, maintenance procedures, training, and on the source and nature of defects and their impact. The QA program permits maintenance and operational decisions to be made based on facts rather than intuition or memory, by providing comparative data that is useful long after the details of a particular event has been forgotten.

A properly functioning QA program points out problem areas to maintenance managers so that appropriate action can be taken to accomplish the following:

- Improve the quality, uniformity, and reliability of the total maintenance effort
- Improve the work environment and the tools and equipment used in the performance of maintenance
- Eliminate unnecessary man-hour and dollar expenses
- Improve the training, work habits, and procedures of maintenance personnel
- Increase the accuracy and value of reports and correspondence originated by the division
- Distribute required technical information more effectively
- Establish realistic material and equipment requirements in support of the maintenance effort
- Support safety and FOD prevention and reporting programs

QUALITY ASSURANCE BRANCH ORGANIZATION

The QA branch is comprised of a small group of skilled personnel who are permanently assigned to the branch. The personnel assigned to the QA branch are known as quality assurance inspectors (QAIs). They are responsible for conducting QAI-level inspections and the management and monitoring of QA programs in the division. Additionally, personnel assigned to other branches and work centers will be designated to perform certain inspection functions NOT requiring QAI-level involvement. These personnel are collateral duty inspectors (CDIs), who are assigned to inspect specific steps of a maintenance procedure performed by their respective work center. They are responsible to the QA branch supervisor while performing QA functions. CDIs are NOT permitted to inspect their own work under any circumstance.

It may also be necessary to augment the QA branch with collateral duty quality assurance inspectors (CDQAIs) to temporarily alleviate given skill or manpower shortages. CDQAIs must meet the same criteria as QAIs, including designation in writing by the commanding officer, and will have the same authority

as QAIs but remain part of their respective work centers. Should it become necessary to assign an individual below the paygrade of E-6 as a CDQAI, a letter must be submitted informing the cognizant type commander (TYCOM) of this decision and the assignment must not exceed a period of 90 days without the approval of the cognizant TYCOM. In no case an individual below the paygrade of E-5 be appointed as a CDQAI.

RESPONSIBILITY FOR QUALITY OF MAINTENANCE

To establish a successful QA program, everyone in the maintenance organization must fully support it. It is not the training, maintenance instructions, or other facilities that determine the success or failure of a QA program, it is the frame of mind of all assigned personnel.

Each person must know that quality work is vital to the effective operation of the maintenance organization. Each must know the specifications required to achieve quality work, as well as the purpose of those specifications.

The person most directly concerned with and responsible for quality workmanship is the work center supervisor. This stems from his responsibility for the proper professional performance of assigned personnel. It is the direct responsibility of the work center supervisor to ensure that the proper level of QA inspection is assigned to the job when the job is assigned to maintenance personnel. This procedure allows the inspector to make a progressive inspection as required. This also ensures that an inspector is not confronted with a job that has been completed before he could inspect it.

Direct communication between the QA branch and the maintenance branch is a necessity and must be energetically exercised. Although the maintenance officer is responsible for the overall quality of the maintenance in the division, branch officers, branch supervisors, and work center supervisors are responsible for ensuring that required inspections are conducted and that quality workmanship is attained.

QUALITY ASSURANCE BRANCH RESPONSIBILITIES AND FUNCTIONS

The QA branch is responsible for the implementation, management, and monitoring of specific programs designed to improve the quality of maintenance, the training of personnel, adherence to

general and specific safety rules, and the analysis of maintenance deficiencies, while minimizing man-hour and material expenditures.

To carry out these responsibilities, personnel assigned to the QA branch perform the following duties:

- Maintain the central TPL for the division. Review incoming technical publications and directives to determine their application to individual maintenance branches, and monitor the management of the dispersed TPLs in the maintenance branches.
- Ensure that all work guides, equipment guide lists, and maintenance requirement cards, and other information used to define or control maintenance are complete and current before issuing to work centers.
- Prepare or assist in the preparation of maintenance instructions (MIs) to ensure that QA objectives and requirements are defined.
- Provide a continuous training program in the techniques and procedures used to conduct inspections. Participate as members of task forces to study trouble areas and submit recommendations for corrective action.
- Establish requirements and qualifications for QAI/CDQAIs and CDIs; review the qualifications of personnel nominated for these positions; and develop and administer written examinations to test the knowledge of personnel nominated for QA positions.
- Provide technical assistance to CDIs and periodically accompany CDIs on assigned inspections and evaluate their performance.
- Monitor and review all requests for departures from specifications, requests for engineering information (REIs), hazardous material reports (HMRs), fast-action discrepancy reports (FADR), feedback reports (FBRs), technical publications deficiency reports (TPDRs), quality deficiency reports (QDRs), and technical manual deficiency/evaluation reports (TMDERs) to ensure that they are clear, concise, and comprehensive prior to submission.
- Monitor the use of precision measuring equipment (PME) to ensure compliance with calibration intervals and safety instructions.

- Inspect all maintenance equipment and facilities to ensure compliance with fire and safety regulations and existence of satisfactory environmental conditions.
- Monitor training, qualification, and licensing of equipment operators and drivers.
- Maintain a Trend Analysis Program, either through the periodic review of inspection records, noting any recurring discrepancies requiring special attention, or at the request of the work center supervisor for a particular problem area on a one-time or continuing basis.
- Develop checklists for auditing work centers and specific maintenance programs.

Billet descriptions are to be prepared for QA personnel to ensure that all QA functions and responsibilities are assigned to individual QAIs assigned to the QA branch.

QUALITY ASSURANCE INSPECTOR QUALIFICATIONS

All personnel being considered for selection as a QAI or CDQAI, should meet the following qualifications:

QAI/CDQAIs

1. Be senior in grade and experience. This is defined to mean a first class petty officer or above with a well-rounded maintenance background. It is recognized though, that unusual circumstances may temporarily require the use of other than E-6 or above personnel. Under these circumstances, the most experienced personnel available, as determined by the maintenance officer, may be temporarily designated as a QAI or CDQAI as required.
2. Have fully developed skills and experience related to the technical fields under their cognizance.
3. Be able to research, read, and interpret drawings, technical manuals, and directives.
4. Be able to write with clarity and technical accuracy.
5. Be stable and excellent in performance.
6. Be observant, alert, and inquisitive.

QAI/CDQAIs are designated in writing by the commanding officer after recommendation by the V-2 maintenance officer, the V-2 division officer, and the air department officer on the ALRE Quality Assurance Inspector Recommendation/Designation form (fig. 6-8).

CDIs

As stated earlier in this chapter, CDIs are assigned to the work centers and are to inspect all work and comply with all QA objectives and requirements during all maintenance actions performed by their respective work centers. They will also be familiar with the provisions of the various QA and maintenance management programs managed and monitored by the QA branch.

QA will establish minimum qualifications for personnel recommended for CDI. All CDIs must be PQS qualified on the particular type of equipment that they are assigned to inspect during maintenance. In addition, while CDIs are performing QA duties, they are responsible to the QA branch supervisor, ensuring that all maintenance, safety, and QA requirements are met by the work center by performing spot checks of all in-progress maintenance and work.

CDIs are designated in writing by the air department officer after recommendation by the V-2 maintenance officer and the V-2 division officer (see fig. 6-8).

All QA inspectors (QAI/CDQAIs and CDIs) will be required to demonstrate their knowledge and ability by passing a written test administered by the QA branch. Personnel assigned to perform QA functions (QAI/CDQAIs and CDIs) will receive continuous training in inspecting, testing, and quality control methods specifically applicable to their area of responsibility. They will also receive cross training in the performance of duties outside their area of responsibility. This training will include local training courses, OJT, rotation of assignments, and required formal equipment and QA training schools.

QUALITY ASSURANCE AUDITS

QA audits are essential elements of an effective QA program. They provide an evaluation of performance and program compliance throughout the division by serving in an orderly method of identifying, investigating, and correcting program deficiencies on a regular basis. Audits are used to evaluate specific

ALRE QUALITY ASSURANCE INSPECTOR RECOMMENDATION/DESIGNATION		
CANDIDATE NAME		RATE
I. WORK CENTER SUPERVISOR RECOMMENDATION In accordance with OPNAVINST 4790.15 the above named person is recommended for: <input type="checkbox"/> QAI <input type="checkbox"/> CDQAI <input type="checkbox"/> CDI		
FOR: (SYSTEM/SUBSYSTEM, ETC.)		
W/C SUPERVISOR	SIGNATURE	DATE
II. QUALITY ASSURANCE ENDORSEMENT The candidate has been examined in accordance with OPNAVINST 4790.15 and has passed all requirements satisfactorily. Recommended approval.		
QA SUPERVISOR TYPED NAME AND RANK	SIGNATURE	DATE
III. ALRE MAINTENANCE OFFICER ENDORSEMENT RECOMMENDED <input type="checkbox"/> APPROVAL <input type="checkbox"/> DISAPPROVAL		
MAINTENANCE OFFICER TYPED NAME AND RANK	SIGNATURE	DATE
IV. V-2 DIVISION OFFICER ENDORSEMENT RECOMMENDED <input type="checkbox"/> APPROVAL <input type="checkbox"/> DISAPPROVAL		
V-2 OFFICER TYPED NAME AND RANK	SIGNATURE	DATE
V. AIR OFFICER ENDORSEMENT/ACTION <input type="checkbox"/> APPROVAL <input type="checkbox"/> DISAPPROVAL <input type="checkbox"/> DESIGNATED <input type="checkbox"/> NOT DESIGNATED		
AIR OFFICER TYPED NAME AND RANK	SIGNATURE	DATE
VI. COMMANDING OFFICER ACTION <input type="checkbox"/> DESIGNATED <input type="checkbox"/> NOT DESIGNATED		
COMMANDING OFFICER TYPED NAME AND RANK	SIGNATURE	DATE
VII. DESIGNEE RESPONSIBILITY I understand my responsibility as set forth herein: "When performing inspections, I am considered to be the direct representative of the Commanding Officer for ensuring operational safety of the item concerned. I will not permit factors, such as operational desires, maintenance consideration, personal relations or the approach of liberty to modify my judgement. By signing an inspection report, I am certifying upon my own individual responsibility that the work involved has been personally inspected by me; that it has been properly completed and is in accordance with current instructions and directives; that it is satisfactory; that any related parts or components which may have been removed by the work are properly replaced and all parts are secure; and that the work has been performed in such a manner that the item is completely safe for use."		
CANDIDATE TYPED NAME	SIGNATURE	DATE

ABEf608

Original to: Quality Assurance
 Copy to: Branch Officer

Figure 6-8.—ALRE Quality Assurance Inspector Recommendation/Designation form.

maintenance programs assigned to the QA branch for either management or monitoring.

Audits fall into three categories:

1. Work center audit—These audits are conducted quarterly to evaluate the overall quality performance of each work center. As a minimum the following areas and items will be evaluated:

- Personnel and skills
- Technical publications
- Maintenance instructions
- Adherence to directives, procedures, and inspections
- Adequacy and availability of process, test, and inspection procedures
- Availability and calibration status of PME
- Proper use of PME
- Certification of personnel performing special processes such as welding and operating yellow gear
- Handling, packaging, protecting, and storing of material and parts
- Cleanliness and condition of spaces
- Compliance with fire and safety regulations
- Configuration of components and equipment, and accuracy of associated logs and records
- Equipment logs and records
- Material condition of equipment
- FOD prevention program compliance
- TCP compliance
- Corrosion control program compliance
- Tag-out program compliance
- General and electrical safety programs compliance

2. Special audits—These are conducted to evaluate specific maintenance tasks, processes, procedures, or programs. They provide a systematic, coordinated method of investigating known deficiencies, evaluating the quality of workmanship, and determining the adequacy of and adherence to applicable technical publications/instructions. Special audits are also used by QA to monitor those programs

specifically assigned to the QA branch for monitoring. Special audits are conducted at the direction of the maintenance officer or QA supervisor on an as required basis.

Audit forms, with appropriate checklists, for each work center is developed by QA. Upon completion of an audit, the findings are reviewed with the branch and work center supervisors; and a report of the findings, with recommendations when required, is submitted to the maintenance officer. Records of audits are maintained for 2 years.

Adequate follow-up procedures must also be established to ensure that discrepancies found during a QA audit are resolved. Attention from all levels within the V-2 division organization is essential.

3. Annual type commander audit—The cognizant type commander maintenance management team conducts an annual audit of each carrier's ALRE QA program.

The Aircraft Launch and Recovery Equipment Maintenance Program (ALREMP), OPNAVINST 4790.15, establishes the maintenance policies, procedures, and responsibilities required to provide an integrated system for performing maintenance and supporting related functions on ship's installed aircraft launch and recovery systems and associated support systems and equipment.

To obtain the full benefits of the QA program, teamwork must first be achieved. Blending QA functions with the interests of the entire division creates a more effective program. Every maintenance person and supervisor must be permitted to use an optimum degree of judgment in the course of daily operations and the performance of daily work assignments. A person's judgment plays an important part in the quality of the work he performs. QA techniques supply each person with information on actual quality, which provides a challenge to improve the quality of his work. The resulting knowledge encourages the best efforts of all maintenance personnel.

REVIEW QUESTIONS

- Q14. True or False: CDIs are permanently assigned to the QA branch?*
- Q15. Who is responsible to ensure that the proper level of QA inspection is assigned to a maintenance action?*
- Q16. Who designates QAIs and CDQAIs?*

Q17. *What are the categories of QA audits?*

SUMMARY

You should now know that overhaul maintenance is restorative or additive work on catapults, arresting gear, VLA, and their associated equipment that is usually performed at a naval overhaul and depot facility, contractor plant, or industrial facility.

You should know that maintenance tasks are assigned according to the complexity, scope, and range of the work to be performed. You have read about the duties of the maintenance control, quality assurance, and maintenance support branches of V-2 division. You should now know the purposes of the maintenance action forms and the procedures for their completion.

You should know that V-2 divisions support naval operations through the upkeep and operation of catapult and arresting gear equipment and that the Aircraft Launch and Recovery Equipment Maintenance Program (ALREMP) makes this type of support possible.

You should also know that the ALREMP program depends heavily on the quality assurance concept and that quality assurance in maintenance is a responsibility of all hands.

Should you not fully understand this chapter, you should thoroughly study it again. You, as an ABE, will be responsible for supporting ALREMP through your knowledge and experience.

CHAPTER 7

MAINTENANCE PLANNING AND ADMINISTRATION

As the workcenter or branch supervisor, you are directly responsible for the maintenance effort of your workcenter. The planning, scheduling, control and parts ordering are essential to its accomplishment.

The factors that you must consider in maintenance planning are equipment status, operational requirements, the workload, and the personnel assets available to perform the job.

PLANNED MAINTENANCE SYSTEM

LEARNING OBJECTIVES: State who has the responsibility for managing PMS programs for equipment aboard ship. Identify three considerations used to determine PMS procedures.

The Planned Maintenance System (PMS) is a simplified, yet thorough means of accomplishing preventive maintenance aboard ship. It identifies maintenance requirements, and schedules maintenance actions to make the best use of your resources. It increases economy and simplifies records. It improves management, workload planning, equipment reliability, and on-the-job training of shipboard personnel. As a system, however, it is neither self-starting nor self-sustained, and careful supervision at all levels is required.

PMS procedures and how frequently the actions should be done are developed for each piece of equipment based on good engineering practices, practical experience, and technical standards. These step-by-step procedures are published on maintenance requirement cards (MRCs). The cards contain detailed information on each maintenance requirement, such as who (specific rate) should perform the maintenance, and when, how, and with what resources. Some MRCs have equipment guide lists (EGLs) to identify the locations of various pieces of the same type of equipment, such as motors, controllers, valves, life rafts, deck fittings, and hatches that are serviced at the same time.

Keep in mind that PMS actions, as preventive maintenance actions, are the minimum maintenance actions required to maintain the equipment in a fully operable condition. If PMS actions are performed

according to schedule, they will allow equipment operators and maintenance personnel to identify possible problems before equipment failure. Properly performed PMS actions will help prevent failures that could result in repeated corrective maintenance actions.

PMS procedures are developed by the activities and offices of the systems commands responsible for the development and procurement of the systems and equipment they control. PMS maintenance index pages (MIPs) and MRCs are developed as part of the Integrated Logistics Support effort for all new procurements, alterations, and modifications of systems and equipment.

Management tools provided by PMS for each ship, department, and supervisor include the following:

- Comprehensive procedures for planned maintenance of systems and equipment
- Minimum requirements for planned maintenance
- Scheduling and control of maintenance
- Description of the methods, materials, tools, and personnel needed to perform maintenance
- Prevention or detection of hidden failures or malfunctions
- Test procedures to determine material readiness

PMS, though standard in concept and procedures, is flexible enough to be adjusted by the ship to be compatible with operational and other types of schedules.

DEPARTMENTAL MASTER PMS MANUAL

A Departmental Master PMS Manual is maintained in each departmental office for use in planning, scheduling, and supervising required maintenance. The information contained in this manual pertains only to equipment for which the department is responsible. The Departmental Master PMS Manual contains the following:

1. **Supplementary Information:** Additional instructions, information, and data provided to

assist in implementation and accomplishment of PMS.

2. **List of Effective Pages (LOEP):** The Departmental LOEP (fig. 7-1) provides a listing of the MIPs assigned to each

department, divided by workcenters, and contains the following information:

- a. Report date (date LOEP was produced).
- b. FR (Force Revision).

Date: 08/23/00
Time: 14:37:51

Planned Maintenance System
List of Effective Pages (PMS 5)

Page: 1
FR: 2-94

Unit: DDG 0053 UIC: R21313 Work Center: EA01 USS JOHN PAUL JONES

Adds/
Changes

MIP

Nomenclature

Adds/ Changes	MIP	Nomenclature
	1631/004-A2	SEA CHESTS
-	2560/006-24	CRCLT AND COOLING SW SYS
	4431/002-63	VISUAL/AUDIO COMM SYSTEMS
	5000/005-A2	VALVES & VALVE OPERATORS
	5000/007-82	ENG REPAIR PROCEDURES
	5140/011-C3	AIR CONDTN SYSTEM (R-114)
-	5161/001-C3	REFRD, SHIP SERVICE (R-12)
	5312/002-32	DISTILLING PLANT VPR CPRSN
	5331/002-33	WATER, POTABLE SERVICE
	5332/001/C0	DISTILLED WATER SERVICE
-	5511/010-44	AIR SYSTEM, HIGH PRESSURE
-	5515/009-44	COMPRESSORS, AIR
	5600/016-44	SHIP CONTROL SYSTEMS
	5713/006-B1	RAS TRANSFER HEAD & SLIDING
	5721/009-31	SHIPS STORES HDLG EQPT
-	5811/020-44	ANCHOR HANDLING & STOWAGE
-	5821/016-44	MOORING AND TOWING SYSTEM
-	5831/013-93	BOAT HANDLING & STOWAGE
-	5832/005-24	LIFE SAVING EQUIP PRESV
-	5833/047-83	SMALL BOATS (ENGINE(CUMN))
-	5833/201-24	SMALL BOATS (EQUIPMENT)
-	5833/202-24	SMALL BOATS (STEERING SYS)
	5833/309-83	SMALL BOAT (WILLARDRIB)
	5931/016-43	SEW/WST WTR POLL CONT SYS
-	6300/001-44	PRESERVATION & COVERINGS
-	6331/002-44	ZINCS (SACRIFICIAL ANODES)
-	6512/002-34	DISHWASHING MACHINE
	6512/027-63	DISHWASHING MACHINE
	6514/NMR	VEGETABLE PEELING MACHINE
-	6515/003-16	MEAT SLICING MACHINE
-	6517/006-34	GARBAGE DISPOSAL

ABEF0701

Figure 7-1.—Departmental LOEP.

- c. Type Commander (TYCOM).
- d. Unit (ship's hull number, UIC, and name).
Shore activity (UIC number).
- e. Workcenter.
- f. MIP number.
- g. Nomenclature (brief description of the system/equipment).

h. Equipment status code.

- 3. **Maintenance Index Pages (MIP):** MIPs are prepared and issued for each installed system or piece of equipment for which PMS support has been established. MIPs are basic PMS reference documents. Each MIP is an index of a complete set of MRCs applicable to a ship system, subsystem, and equipment. MIPs (fig. 7-2) contain the following information:

SHIP SYSTEM, SYSTEM, SUBSYSTEM, OR EQUIPMENT		REFERENCE PUBLICATIONS		DATE			
Fire Extinguishing System, Fog, Foam, and AFFF 5551		NAVSEA S8225-GY-MMA-010 NAVSEA S9555-AN-MMO-010		May 2000			
T	O	SYSKOM MRC CONTROL NO	MAINTENANCE REQUIREMENT DESCRIPTION	PERIODICITY CODE	RATES	MAN HOURS	RELATED MAINTENANCE
			A scheduling aid; Review maintenance requirements. Omit MRC(s) which do not apply; no feedback report required. # Mandatory scheduling required.				
		46 6UMU N	1. Inspect high-capacity AFFF injection station.	D-1	HT2	0.2	None
		42 8UNR N	1. Inspect proportioner station FP-180.	D-2	HT2	0.2	None
		42 8UNQ N	1. Turn AFFF proportioner shaft by hand. 2. Inspect oil level in AFFF proportioner.	W-1	HT/DC3	0.4	None
4		B4 6UMV N	1. Inspect high capacity AFFF injection station operation. 2. Test AFFF concentrate for seawater contamination.	Q-1	HT3 FN	2.0 0.5	None
4		80 6DAA N	1. Test operate, inspect, and clean 1000 gpm AFFF proportioner station.	Q-2	HT/DC3 FN	2.0 0.5	None
4		16 6DAD N	1. Test AFFF concentrate for seawater contamination at FP-180 station.	Q-3	HT3	2.0	None
		88 8DRU N	1. Clean and inspect hose reel stations.	Q-4	HT/DC3	0.5	None
		44 6UMW N	1. Lubricate AFFF injection pump bearings.	Q-5	HT3 EM3	0.3 0.3	Q-1
4		54 C1TH N	1. Test operate, inspect, and clean AFFF FP-180 station. 2. Lubricate FP-180 proportioner. NOTE: Accomplish quarterly or after each use, whichever occurs first.	Q-6R	HT/DC3 FN	2.0 0.5	None
		97 8GMG N	1. Accomplish liquid foam quantitative analysis at FP-180 stations.	S-2	DCA HT1 HG3	0.7 0.4	D-2# Q-3# Q-4# or R-1#
		44 6UMY N	1. Change oil in AFFF injection station reducer.	S-3	HT3	0.4	None
		38 8HQR N	1. Inspect AFFF bilge sprinkling system nozzles.	S-4	HT/DC HTFN/ DCFN	1.0 1.0	None
		39 6UMZ N	1. Accomplish AFFF concentration analysis	A-1	HT/DC HG/DC2	0.7 0.4	D-1# Q-1# Q-4# or R-1#
		44 6UNA N	1. Lubricate high-capacity AFFF injection station flexible couplings.	A-2	HT3	0.8	None
		10 8NPR N	1. Inspect and hydrostatically test AFFF station hose(s)..	A-3	HT/DC2 2FN	0.3 0.6	None
DISTRIBUTION STATEMENT D Distribution authorized to DOD components and DOD contractors only; critical technology; May 1994. Other requests for this document shall be referred to Naval Sea Systems Command (SEA 04TD). Destroy by any method that will prevent disclosure of contents or reconstruction of the document.							

Figure 7-2.—Maintenance Index Page (MIP).

- a. Ship system, subsystem, or equipment description of noun name.
- b. Reference publications about the system, subsystem, or equipment.
- c. Date: Preparation date of the MIP by month and year.
- d. Test, Other, and SYSCOM MRC control number columns.

MIP	Nomenclature	Work Center Distribution		
1230/001-54	TANKS, VOIDS, AND TRUNKS	EM04		
1501/001-32	SUPERSTRUCTURE & FITTINGS	ER01		
1631/004-A2	SEA CHESTS	EA01	EM01	EM02
1671/003-33	ARMORED DOORS & HATCHES	ER09		
1671/005-B1	WTRTT, DR, TORPEDO MAGAZINE	ER09		
1672/001-32	ARMORED DOORS & HATCHES	ER09		
1681/002-32	DECKHOUSE STRUCT CLOSURES	ER09		
1921/001-A9	COMPARTMENT TESTING	ER01		
2000/001-A2	MACHINERY LUBRICATING OIL	EM01	EM02	EM04
2340/004-44	MAIN PROPULSION GAS TURBIN	EM01	EM02	
2400/013/-44	XMSN & PROPULSOR SYSTEMS	EM01	EM02	
2411/015-44	PRPLN REDUCTION GEARS	EM01	EM02	
2421/002-C2	PROPULSION CLUTCH COUPLING	EM01	EM02	
2451/006-33	PROPELLERS AND PROPULSORS	EM01	EM02	
2513/007-34	COMBUSTION AIR SYSTEM	EM01	EM02	
2521/051-54	AUTO PROPULSION CTRL SYS	EM03		
2560/006-24	CRCLT AND COOLING SW SYS	EA01	EM01	EM02
2591/001-44	UPTAKES AND BAFFLES	EM01	EM02	
2610/059-54	FUEL SERVICE SYSTEM	EM01	EM02	EM04
2620/013-44	MAIN PROPULSION LO SYSTEM	EM01	EM02	EM03
2640/012-44	LO FILLXFR PURIFICATION	EM01	EM02	EM03
3000/001-14	MISC SHIPBOARD ELECT EQUIP	EE01	EM03	
3001/002-C2	MISC CONTROLLERS	EE01	EM03	
3002/001-24	MISC AC/DC MOTORS	EE01	EM03	
3113/004-44	S/S GAS TURBINE GEN SET	EM01	EM03	
3131/005-24	BATTERY/SERV FACILITIES	EE01		
3201/002-34	POWER CABLES (CASUALTY)	EE01		
3241/051-34	SWITCHGEAR AND PANELS	EE01	EM03	
3301/002-34	LIGHTING AND DISTRIBUTION	EE01		
3431/002-44	SSGTG SUPPORT SYSTEMS	EM01	EM03	EM03

ABE0703

Figure 7-3.—Example of an MIP to Workcenter File.

- e. Maintenance requirement: A brief description of each maintenance requirement.
- f. Periodicity code: Shows how frequently the maintenance is to be performed.
- g. Rate (skill level): Identifies the recommended skill level of the person(s) considered capable of performing the maintenance requirement. Qualified personnel other than the rate/rating specified may be assigned. When a Navy Enlisted Classification (NEC) is assigned, substitution of other personnel is not allowed.
- h. Man-hours (MH): Total time required to do the maintenance.
- i. Related maintenance.
 - (1) Mandatory
 - (2) Convenience
 - (3) None
- j. Scheduling aids: Amplifying instructions, if needed, are located in the maintenance requirement description block.
- k. SYSCOM MIP control number.
- l. Inactive equipment maintenance (IEM): Maintenance performed when specific equipment will remain inactive for 30 days or longer and is not scheduled for repair, maintenance, or overhaul by either the ship's force or an external repair activity.

4. The Departmental Master PMS Manual also includes a MIP to Workcenter File (fig. 7-3).

WORKCENTER PMS MANUAL

The Workcenter PMS Manual contains only the planned maintenance requirements applicable to a particular workcenter. It is designed to provide a ready reference of planned maintenance requirements for the workcenter supervisor and should be retained in the working area, near the Weekly PMS Schedule, in the holder provided.

Maintenance Requirement Cards (MRCs)

Maintenance Requirement Cards (MRCs) (fig. 7-4) provide the detailed procedures used to perform a

maintenance action and state who is to perform the maintenance and what is to be done, and when, how, and with what resources a specific requirement is to be accomplished. MRCs contain the following information and instructions:

SHIP SYSTEM, SYSTEM, SUBSYSTEM, EQUIPMENT.—These blocks contains the identification of the ship system (functional group), system, subsystem, or equipment involved.

MRC CODE.—The MRC code consists of two parts. The first part of the MRC code is the MIP series code. MRCs applicable to more than one MIP series will have each MIP series entered in this block. If more than four MIP series apply, reference will be made to a note in the Procedure block. The second part is the maintenance requirement periodicity code. The only authorized periodicities are listed in Table 7-1.

The periodicity code also includes a number for specific identification. When more than one MRC of the same periodicity exists in the same MRC set, the MRCs, in most cases, will be numbered consecutively; for example, D-1, D-2, D-3, or M-1, M-2, M-3. An existing MRC may be reapplied to a revised MIP even though the periodicity code of the reapplied MRC may not fall within the normally sequential numeric periodicity codes. For example, W-1, W-2, W-3, and W-6 may appear on a MIP, since W-6 was an existing MRC that was reapplied to this equipment. Technically, valid MRCs will not be reprinted merely to change the periodicity code number. Nonsequential numbers will not affect scheduling or management control.

Dual periodicity codes are used when configurations or utility differences of a permanent nature exist between installations of the same system/equipment. A dual periodicity may be assigned if no other aspect of the MRC requires modification to fit both periodicities. For example, equipment installed in an SSN or in a surface unit may see daily use, while the same equipment installed in an SSBN may be idle for long periods of time because of the nature of the ship's mission. This long period of idleness may result in less frequently performed maintenance requirements. In this case a dual periodicity, such as M-1/Q-I or Q-1/S-2, may be assigned. When dual periodicities are assigned a note on the MIP and the MRC will specify the frequency of maintenance, for example, "NOTE: SSBN, schedule quarterly; all others schedule monthly." The unrequired periodicity should be deleted by having a line drawn through it.

SHIP SYSTEM Miscellaneous Shipboard Electrical Equip and Installed Receptacles 3000		SUBSYSTEM Miscellaneous Shipboard Electrical Equip and Installed Receptacles 3000		MRC CODE 3000 M-4/ Q-2R	
SYSTEM Miscellaneous Shipboard Electrical Equip and Installed Receptacles 3000		EQUIPMENT Miscellaneous Shipboard Electrical Equip and Installed Receptacles 3000XY		RATES	M/H
				EM2	0.1
				EMFN	0.1
MAINTENANCE REQUIREMENT DESCRIPTION 1. Inspect portable electrical tool/device equipped with two-prong plug. 2. Measure Insulation resistance.				TOTAL M/H 0.2 ELAPSED TIME 0.1	
SAFETY PRECAUTIONS 1. Forces afloat comply with Navy Safety Precautions for Forces Afloat, OPNAVINST 5100 series. 2. Ensure all tag-out procedures are in accordance with current shipboard instructions. 3. Tool test set (SCAT 4547) can produce voltages dangerous to life. Wear rubber gloves.					
TOOLS, PARTS, MATERIALS, TEST EQUIPMENT					
TEST EQUIPMENT			MISCELLANEOUS		
1. [0399] Electrical tool testers, SCAT-4547, 07239-235000			1. [0526] Gloves, electrical workers, 7500 volt maximum safeuse, size 9, rubber		
2. [0883] Megger, 500V, 100MOhm, SCAT-4452					
3. [0901] Multimeter, AC/DC, SCAT-4245					
MATERIALS					
1. [0096] Pen, ball-point					
2. [1144] Tag, safety					
3. [1657] Tag, safety check					
4. [2277] Pad, writing paper					
NOTE: Numbers in brackets can be referenced to Standard PMS Materials Identification Guide (SPMIC) for stock number identification.					
PROCEDURE					
NOTE 1: For equipment issued on permanent or semi-permanent loan to work centers, accomplish monthly, all other accomplish quarterly or before each issue. For repair locker equipment, accomplish quarterly or after each use, whichever occurs first.					
DISTRIBUTION STATEMENT D Distribution authorized to DOD components and DOD contractors only; critical technology; February 1994. Other requests for this document shall be referred to Naval Sea Systems Command (SEA 04TD). Destroy by any method that will prevent disclosure of contents or reconstruction of the document.					
LOCATION Equipment Guide List Recommended				DATE February 2000	

PAGE 1 OF 3

24

4ABG

N

MAINTENANCE REQUIREMENT CARD (MRC)

OPNAV 4790 (REV. 2-82)

ABE0704

Figure 7-4.—Maintenance Requirement Card (MRC).

Table 7-1.—Periodicity Codes

PERIODICITY CODES	
D - Daily	S - Semiannually
2D - Every 2nd day	8M - Every 8th month
3D - Every 3rd day	A - Annually
W - Weekly	18M - Every 18 months
2W - Every 2nd week	24M - Every 24 months
3W - Every 3rd week	30M - Every 30 months
M - Monthly	36M - Every 36 months
2M - Every 2d month	48M - Every 48 months
Q - Quarterly	54M - Every 54 months
4M - Every 4th month	60M - Every 60 months
NON-CALENDAR PERIODICITY	
R - Situation requirement	
U - Unscheduled maintenance	
INACTIVE EQUIPMENT MAINTENANCE (IEM)	
LU - Lay-up	
PM - Periodic maintenance	
SU - Start-up	
OT - Operational test	

Situation requirement codes may be used with a calendar periodicity code in certain circumstances. These situations fall within two general categories:

- When the situation governs the scheduling of the requirement
- When the calendar periodicity governs the scheduling of the requirement

For example, consider the occasion of weekly measurement of values when a certain system is in operation. The measurement of these values will not be required when the equipment is not being operated, regardless of how prolonged the idle period may be. There are cases in which requirements must be scheduled with regard to the situation rather than the calendar timing. The periodicity code will state the R for situation first, and after the hyphen and a unique number, a letter will recognize the calendar contingency. An example of a situation-calendar periodicity code is that an R-IW requires you to

schedule equipment lubrication weekly when at sea. That means that the R-IW is entered into a daily column of the weekly schedule only when the ship is at sea. During in-port times the R-IW will remain in the Outstanding Repairs and PM Checks Due In Next 4 Weeks column.

When the periodicity code is of the calendar-situation combination, the calendar controls the scheduling and is only occasionally overtaken by the situation. The calendar periodicity is referred to first in the code, for example, 18M-2R. In the example, the 18M indicates that the longest time between accomplishment is every 18 months, and the 2R indicates that a situation could arise which would require it to be done more often. An explanation of such situations will appear on the MRC. When the situation no longer exists, scheduling reverts to the 18-month period. Some examples of the combined calendar and situation requirements are as follows:

M-1R: Monthly or every 600 hours, whichever occurs first.

W-3R: Weekly or after each use, whichever occurs first.

S-1R: Semiannually or during each upkeep period, whichever occurs first.

Q1-1R: Quarterly or prior to getting underway, whichever occurs first.

When the periodicity code includes a situation requirement (such as R-1 or Q-1R), a note of explanation is required in addition to the basic code. This note is the first entry in the Procedure block.

MAINTENANCE REQUIREMENT DESCRIPTION.—The maintenance requirement description is a brief definition of the PMS action to be performed.

RATES.—The rate is the recommended skill level of the person who should be qualified to do the work, identified by rate or NEC (Navy Enlisted Classification). Qualified personnel other than those specified may be assigned. When more than one person in the same rate is required, the appropriate number of persons precedes the rate. When more than one person in the same rate is required and time requirements are not equal, each person is listed separately.

MAN-HOURS (M/H).—Man-hours is the average amount of time required of each rate listed in the Rates block to perform the maintenance, on each piece of identical equipment, listed in hours and tenths of an hour. When more than one person in the same rate is required and time requirements are equal, man-hours listed are the sum of their requirements. When more than one person in the same rate is required and time requirements are not equal, man-hours are listed for each person separately. Total man-hours are the sum of all entries in the M/H block. Make ready and put away time, including removal and/or replacement of anything that interferes with the maintenance (covers, other equipment, and so on) is not included.

SAFETY PRECAUTIONS.—This section of the MRC provides a listing of precautions and publications that direct attention to possible hazards to personnel or equipment during maintenance. The word “NOTE” will precede procedural advisories. Specific categories of direction are as follows:

- **Warning:** Explains operating procedures, practices, and so forth, that, if not followed

correctly, may lead to injury or death. Warnings are listed in the Safety Precautions block and are repeated preceding the procedure involved.

- **Caution:** Explains operating procedures, practices, and so forth that, if not correctly followed, may lead to damage to equipment. Cautions are not listed in the Safety Precautions block; however, they do precede the instructions for the procedure involved.

TOOLS, PARTS, MATERIALS, TEST EQUIPMENT.—This section lists the test equipment, materials, parts, tools, and miscellaneous requirements necessary to perform the maintenance action. Each of the above categories may include both Standard PMS Item Name (SPIN) and non-SPIN items. Entries in this block can be cross-referenced to the Standard PMS Materials Identification Guide (SPMIG) for stock number identification.

Equipment Guide List (EGL)

The EGL (OPNAV Form 4790/81) (fig. 7-5) is a 5x8-inch card that is used with a controlling MRC when the MRC applies to a number of identical items, such as motors, controllers, life rafts, valves, test equipment, and small arms. Each ship prepares its own EGLs.

The number of items included on an EGL is directly related to the time to do the maintenance on each item. Each EGL normally contains no more than a single day's work. If more than 1 day is required, separate EGL pages are prepared for each day and are numbered consecutively.

In some instances it may be unnecessary or impractical to list the equipment on EGLs. For instance, if the equipment is listed on a TYCOM-directed checklist or if an Automated Calibration Recall Program is in effect, a notation of the applicable instruction in the Location block of the MRC is all that is required.

Tag Guide List (TGL)

The TGL (OPNAV Form 4790/107) (fig. 7-6) contains the information necessary for equipment tag-out required during PMS actions. The TGL contains the number of tags required, locations of the tags, position of each tagged item (open, shut, off, on, and so on) and permission or notification requirements. Each ship prepares its own TGLs.

Location of MRCs, EGLs, and TGLs

A master MRC deck is maintained at the departmental level. Each departmental master deck contains only one copy of applicable MRCs filed by SYSCOM control number. Applicable master EGLs

and TGLs are attached to related master MRCs. In addition, a complete working deck of applicable MRCs, EGLs, and TGLs is located in MRC holders in each workcenter. Maintenance personnel use these to perform assigned planned maintenance.

SEE INSTRUCTIONS ON BACK OF GREEN PAGE		REPORT SYMBOL OPNAV 4790-4
FROM (SHIP NAME AND HULL NUMBER) USS NEVERWAS FFG 999		SERIAL # 1074-94
		DATE 09 MAR 94
TO		
<input checked="" type="checkbox"/> NAVAL SEA SUPPORT CENTER, PACIFIC (Category A)		
<input type="checkbox"/> TYPE COMMANDER (Category B)		
SUBJECT: PLANNED MAINTENANCE SYSTEM FEEDBACK REPORT		
SYSTEM, SUB-SYSTEM, OR COMPONENT SONAR RECEIVING SET	APL/CID/AN NO./MK. MOD AN/SQR-18A (V) 1	
SYSCOM MIP CONTROL NUMBER 4621/23-23	SYSCOM MRC CONTROL NUMBER VARIOUS	
DESCRIPTION OF PROBLEM		
CATEGORY A	CATEGORY B	
<input checked="" type="checkbox"/> MIP/MRC REPLACEMENT	<input type="checkbox"/> TECHNICAL <input type="checkbox"/> TYCOM ASSISTANCE <input type="checkbox"/> OTHER (Specify)	
REMARKS		
REQUEST TWO COPIES EACH OF FOLLOWING CLASSIFIED MRCs:		
72 EZV9 N		
12 EZV0 N		
20 EZW5 N		
TOTAL OF 6 MRCs REQUESTED. ADEQUATE SECURE STORAGE PER OPNAVINST 5110.1H IS AVAILABLE.		
ORIGINATOR & WORK CENTER CODE ET (SW) Boat EE01	DIV. OFFICER LT Jay Gee	
DEPT. HEAD I. M. Daboss, CDR, USN	3-M COORDINATOR GMC (SW) Jack Frost	
<small>Originator do not write below. For TYCOM use only.</small>		
TYCOM <input type="checkbox"/> CONCUR	<input type="checkbox"/> DO NOT CONCUR	<input type="checkbox"/> TAKES ACTION
		<input type="checkbox"/> PASSES FOR ACTION
TYCOM REP SIGNATURE	DATE	
OPNAV 4790/7B (Rev. 9-89) ACTION COPY PAGE <u>1</u> OF <u>1</u> S/N 0107-LF-007-8000 EDITION OF 3-84 MAY BE USED UNTIL EXHAUSTED		

ABE0707

Figure 7-7.—PMS Feedback Report, category A.

PMS Feedback Report (FBR)

The PMS Feedback Report (FBR) (OPNAV 4790/2B) is a form used by maintenance personnel to notify NAVSEACEN, NAVAIRENGCEN, and

TYCOM, as applicable, of technical and nontechnical matters related to PMS. The FBR is a five-part form composed of an original and four copies. Figures 7-7 and 7-8 provide examples of FBRs. Instructions for

SEE INSTRUCTIONS ON BACK OF GREEN PAGE		REPORT SYMBOL OPNAV 4790-4
FROM (SHIP NAME AND HULL NUMBER) USS NEVERWAS FFG 999		SERIAL # 1074-94
		DATE 04 MAR 94
TO		
<input type="checkbox"/> NAVAL SEA SUPPORT CENTER _____ (Category A)		
<input checked="" type="checkbox"/> TYPE COMMANDER (Category B)		
SUBJECT: PLANNED MAINTENANCE SYSTEM FEEDBACK REPORT		
SYSTEM, SUB-SYSTEM, OR COMPONENT Auto Ballast Comp Sys	APL/CID/AN NO./MK. MOD	
SYSCOM MIP CONTROL NUMBER F-37/2-67	SYSCOM MRC CONTROL NUMBER T 44 E12F N	
DESCRIPTION OF PROBLEM		
CATEGORY A	CATEGORY B	
<input type="checkbox"/> MIP/MRC REPLACEMENT	<input checked="" type="checkbox"/> TECHNICAL	
	<input type="checkbox"/> TYCOM ASSISTANCE	
	<input type="checkbox"/> OTHER (Specify)	
REMARKS		
<p>Before testing setting on relief valve, we need calibration steps for Leslie-Matic controller. This step is not contained on the present MRC. This ship does not have any pub or tech manual showing the steps that should be taken in checking the Leslie-Matic controller for accuracy.</p>		
ORIGINATOR & WORK CENTER CODE ET (SW) Boat EE01	DIV. OFFICER Lt Jay Gee	
DEPT. HEAD I.M. Daboss, CDR, USN	3-M COORDINATOR GMC (SW) Jack Frost	
<small>Originator do not write below. For TYCOM use only.</small>		
TYCOM <input type="checkbox"/> CONCUR	<input type="checkbox"/> DO NOT CONCUR	<input type="checkbox"/> TAKES ACTION
		<input type="checkbox"/> PASSES FOR ACTION
TYCOM REP SIGNATURE	DATE	
OPNAV 4790/7B (Rev. 9-89) ACTION COPY PAGE <u>1</u> OF <u>1</u> S/N 0107-LF-007-8000 EDITION OF 3-84 MAY BE USED UNTIL EXHAUSTED		

ABE10708

Figure 7-8.—PMS Feedback Report, category B.

preparation and submission of the form are printed on the back of the last copy (fig. 7-9).

PMS FBR Categories

There are two categories of FBRs—category A and category B—defined as follows:

1. **Category A**—This category (fig. 7-7) is nontechnical in nature and is intended to meet PMS needs that do not require technical review. Category A FBRs are submitted to request classified or other PMS documentation which cannot be obtained locally. With the ship's master PMS requirements on compact

1. ORIGINATOR

- a. Typewritten copies are preferred, however, handprinted copies are acceptable. Use ballpoint pen and ensure all copies are legible.
- b. EQUIPMENT IDENTIFICATION: Fill in titled blocks that apply. Give as much information that can be determined. Ensure that correct APL number is used for hull, mechanical or electrical equipment or electronic/weapons equipment which does not have any Army-Navy number or mark/mod designation.
- c. DESCRIPTION OF PROBLEM: Check the appropriate box.

Category A

- (1) MIP/MRC REPLACEMENT: Ensure that PMS documentation request is current in accordance with latest SFR. For missing MIPs/MRCs, give SYSCOM control numbers when they can be determined. If SYSCOM control numbers cannot be determined, provide as much nameplate data as can be obtained. When ordering a variety of missing/worn MIPs/MRCs, the subject section shall be left blank.

Category B

(2) TECHNICAL:

- (a) Identify specific discrepancy discovered in PMS by MRC control number, step number, etc.
- (b) For publication discrepancies identify publication by number, volume, revision date/number, change number, page, paragraph and or figure as appropriate.

THIS FORM WILL NOT BE USED TO ORDER PUBLICATIONS.

- (3) TYCOM ASSISTANCE: Includes clarification of 3-M instructions and other matters related to PMS administration.
- (4) OTHER: Identify in detail any problem not covered by (1) through (3) above. Shifts of maintenance responsibility will be reported under this item. Ensure that all work centers involved in the change are identified by work center code. Approval by the Executive Officer will be shown in the "Remarks".

- d. REMARKS: Provide brief, but complete, description of problem or requirement. Executive Officer indicate approval of maintenance responsibility shift by endorsement. Use additional forms if more space is required. Mark additional forms, "page 2 of 2", "page 2 of 3", etc. Staple additional forms behind basic form.

- e. ORIGINATOR IDENTIFICATION: Sign and insert work center code in appropriate space.

2.. DIVISION OFFICER: Review for accuracy and completeness and sign in the space provided.

3. DEPARTMENT HEAD: Review for accuracy and completeness and sign in the space provided.

4. 3-M COORDINATOR:

- a. Serialize, date and sign in the appropriate spaces.
- b. ROUTING INSTRUCTIONS: For Category "A" FBRs, forward the white and yellow copies to the appropriate NAVSEACEN and the pink copy to the TYCOM. For Category "B" FBRs, forward the white, yellow and pink copies to the TYCOM. Retain blue copy in suspense file. Return green copy to the originator.

disk, replacement copies will be generated with the print-on-demand capability.

2. **Category B**—This category (fig. 7-8) is technical in nature. These FBRs are submitted by the ship's 3-M coordinator to the applicable TYCOM and pertain to the following:
 - a. Technical discrepancies that inhibit PMS performance. These discrepancies can exist in documentation, equipment design, maintainability, reliability, or safety procedures as well as operational deficiencies in PMS support (parts, tools, and test equipment).
 - b. Shift of maintenance responsibilities. Individual ships sometimes desire or need to shift maintenance responsibility from one workcenter to another, combine two or more existing workcenters, or split an existing workcenter. Such changes can only be made with the approval of the type commander. When changes in maintenance responsibility are considered necessary, ship's personnel should submit a PMS FBR (category B) via the applicable TYCOM, indicating from which workcenter(s) equipment is to be deleted and to which workcenter(s) it is to be transferred. All such FBRs are signed by the executive officer.

Preparation of the PMS FBR

The FBR is prepared and submitted according to the instructions contained on its reverse side (fig. 7-9).

REVIEW QUESTIONS

- Q1. *What is Inactive Equipment Maintenance (IEM)?*
- Q2. *The workcenter PMS manual contains what requirements?*
- Q3. *What provide the detailed procedures used to perform a maintenance action?*

PMS SCHEDULES

LEARNING OBJECTIVE: Describe the types of information displayed on each of the following PMS schedules: Cycle, Quarterly, and Weekly. State the purpose of each schedule.

PMS schedules are categorized as Cycle, Quarterly, and Weekly Schedules.

CYCLE PMS SCHEDULE

The Cycle PMS Schedule (fig. 7-10) displays the planned maintenance requirements to be performed during the period between major overhauls of the ship; that is, from the first quarter after overhaul to the next first quarter after a ship's overhaul. For ships in phased maintenance or similar incremental overhaul programs and other short industrial availability programs, the first quarter after overhaul is the quarter immediately following completion of the docking availability. Cycle and multi-month requirements need to be scheduled during this time period. Any checks that have not been accommodated in this cycle period are front loaded into the new cycle schedule period.

Content of the Cycle PMS Schedule

The following information is found in the block/column indicated in figure 3-10:

- Ship-The ship's name and hull number
- Workcenter-The applicable workcenter designator
- Schedule Quarter After Overhaul As Indicated-The annual, semiannual, multiple-month (4M and greater) maintenance requirements, and any related maintenance checks to be completed during the quarter indicated
- Approval Signature/Date-The department head's signature and the date the Cycle Schedule was approved
- Each Quarter-Maintenance that is performed every 2 weeks, monthly, every 2 months, quarterly maintenance requirements, and any related maintenance checks and situation requirements regardless of periodicity to be completed during each quarter are listed in this column.

Preparation of the Cycle PMS Schedule

Cycle PMS Schedules are used to plan and schedule maintenance requirements to be conducted during each calendar quarter. Department heads devote considerable attention to the preparation of the Cycle Schedule since these efforts directly affect long range

CYCLE PMS SCHEDULE (CONVENTIONAL)
OPNAV FORM 4790/13 S/N 0107-LF-3220

SHIP	WORK CENTER	SCHEDULE QUARTER AFTER OVERHAUL AS INDICATED						APPROVAL SIGNATURE		
		13 ⊗	14 ⊗	15 ⊗	16 ⊗	17 ⊗	18 ⊗	19 ⊗	20 ⊗	
MIP	COMPONENT	9	21	10	22	11	23	12	24	DATE
										EACH QUARTER
USS ROOSEVELT CVN-71	EA07 (pg 1 of 1)									<i>B. A. Olson LCDR, USN</i>
2000/001	MACHINERY LUB OIL NO. 1 AMR			18M-1 (6) (18)				18M-1 (12) (24)		2M-6, R-1
3000/001	MISC SHIPBOARD ELECT EQUIPMENT			S-4R				S-4R		S-4R M-1, M-2, M-4R, R-2
	RECEPTACLES EGL-1			A-2						2W-1, 3W-2
	RUBBER GLOVES EGL-1			S-3R				S-3R		S-3R, R-1
5210/009	FIREMAIN & FLUSHING	S-2				S-2				Q-1, Q-5R#
5510/018	COMPRESSED AIR SYSTEM EA07-001	A-11				A-5R#				A-5R# M-1, M-2, R-1, R-5W
5530/001	02N2 SYSTEM FWD 1-30-6	S-1#				S-1#		A-14#		M-1, M-2 , Q-2# <i>BAO</i>
	PUMP 27345			A-1						Q-3, R-16D, R-17W
	VALVES EGL-1	A-13R								A-13R, R-11M, D-1R, W-1R
	VALVES EGL-2			A-13R						D-1R, W-1R, A-13R, R-11M

Figure 7-10.—Cycle PMS Schedule.

ABEF0710

PMS scheduling. The materials required and the procedures followed in schedule preparation are detailed in the paragraphs that follow.

MATERIALS REQUIRED FOR PREPARATION.—The following materials are required:

- Blank Cycle Schedules (OPNAV 4790/13 or approved automated form). Use of automated forms generated from PMS scheduling programs that have been approved by CNO and the TYCOM are authorized for use in lieu of paper forms
- Workcenter PMS Manuals (List Of Effective Pages) (LOEP)
- Applicable MRCs (for general reference)

PROCEDURES.—The following are basic instructions for filling out the cycle schedule (refer to figure 7-10):

1. Neatly enter initial entries, either typed or in black ink, on the Cycle Schedules. Changes

will be made in ink and initialed by the department head.

2. From the LOEP (Report PMS 5), list each item of equipment in MIP sequence. It is not necessary for the Cycle Schedule to match the LOEP line for line.
 - a. Use the MIP column to list the MIP code without the date coding; for example, E-1/55, EL-2/80, and 4411/1.
 - b. Use the Component column to list the name of each system, subsystem, or equipment. Enter the item's serial number or ship's numbering system number in the Component column if more than one of the items is located within a workcenter. Also enter EGL in this column when an EGL is applicable. When multiple EGLs are used, they can either be scheduled on separate lines or be scheduled on the same line (or group of lines) using the EGL number as the prefix to the scheduling code; that is, a quarterly check for MRC Q-1 would be

scheduled as 1-Q-1 on the same line with 2-Q-1, 3-Q-1, and so on. These techniques permit the use of a reasonably compact schedule for MIPs with large quantities of EGLs that are normally found on large ships, such as aircraft carriers.

3. From the applicable MIP, list the periodicity codes in the Schedule Quarter After Overhaul As Indicated and Each Quarter columns as described in the sections that follow. From the Related Maintenance column of the MIP schedule all mandatory related maintenance requirements which are to be completed during the quarter are indicated by the pound sign symbol "#". The pound sign placed next to a primary check, indicates that there is mandatory related maintenance associated with that maintenance requirement (e.g. S-1#).
 - a. In the Schedule Quarter After Overhaul As Indicated column:

- (1) List each semiannual (S) maintenance requirement in one of the four columns, and then list it again 6 months later. For example, an S-1 requirement scheduled to occur in the 1st, 5th, and 9th quarters is also scheduled in the 3d, 7th, and 11th quarters.
- (2) List each annual (A) maintenance requirement in one of the four columns.
- (3) List each multiple month periodicity MR (18M, 24M, 30M, 36M, and so on). The quarter after overhaul must be indicated in parentheses. (For example, 18M-1(6) indicates an "every 18 months" periodicity MR scheduled to be accomplished in the sixth quarter after overhaul.) Table 7-2 serves as an example for determining the quarter after overhaul. To use the

Table 7-2.—Multiple Month Periodicity Scheduling Table

(NUMBERS INDICATE QUARTER AFTER OVERHAUL)	
18M Scheduling Table	
First Scheduling	1 2 3 4 5 6
Second Scheduling	7 8 9 10 11 12
Third Scheduling	13 14 15 16 17 18
Fourth Scheduling	19 20 21 22 23 24
24M Scheduling Table	
First Scheduling	1 2 3 4 5 6 7 8
Second Scheduling	9 10 11 12 13 14 15 16
Third Scheduling	17 18 19 20 21 22 23 24
30M Scheduling Table	
First Scheduling	1 2 3 4 5 6 7 8 9 10
Second Scheduling	11 12 13 14 15 16 17 18 19 20
Third Scheduling	21 22 23 24 25 26 27 28 29 30
36M Scheduling Table	
First Scheduling	1 2 3 4 5 6 7 8 9 10 11 12
Second Scheduling	13 14 15 16 17 18 19 20 21 22 23 24
48M Scheduling	
First scheduling in first 16 quarters and second scheduling 16 quarters later.	
60M Scheduling	
First scheduling in first 20 quarters and second scheduling 20 quarters later.	

table, first determine in which quarter after overhaul the MR will be first scheduled. Go to this quarter in the first row of the table. Then schedule the MR for the quarters in that column as applicable. For example, if an 18M-1 is scheduled for the 4th quarter after overhaul, it must also be scheduled for the 10th, 16th, and 22d, as applicable.

NOTE

Prior to scheduling 30M, 36M, 48M, or 60M, review the MRC to see if a specific quarter after overhaul is indicated.

- (4) Ships with overhaul cycles of less than 24 quarters must schedule cycle requirements within this operational time frame. Ships delayed beyond 24 quarters must extend their Cycle PMS Schedule by adding quarter numbers in the Schedule Quarter After Overhaul As Indicated column. (Multiple month requirements needed before entering overhaul must be reviewed and rescheduled as necessary.)
- b. In the Each Quarter column, list every 2 weeks, monthly, every 2 months, and quarterly maintenance requirements (2W-1, M-1, 2M-1, Q-1, and so on), and situation requirements (M-IR, Q-IR, S-IR, A-IR, 18M-IR, R-1, and so on). Daily, every 2d day, every 3d day, and weekly maintenance requirements are not listed here.
4. Have the completed Cycle PMS Schedule reviewed, signed, and dated by the department head.
5. Once the Cycle Schedule has been completed, maintenance requirements listed are not to be moved from one quarter to another. If rescheduling becomes necessary, reflect it on the Quarterly PMS Schedules.
6. All superseded cycle schedules will be retained for 12 months.

QUARTERLY PMS SCHEDULE

The Quarterly PMS Schedule (OPNAV Form 4790/14) (fig. 7-11) displays each workcenter's PMS

requirements to be performed during a specific 3-month period. This schedule, when updated weekly, provides a ready reference to the current status of PMS for each workcenter. This schedule represents a departmental directive and, once completed, may be changed only at the department head's discretion. Responsibility for changes is sometimes delegated to division officers on carriers and cruisers.

Contents of the Quarterly PMS Schedule

The Quarterly PMS Schedule contains the following:

- Space is provided for entering the workcenter, year, quarter after overhaul, department head's signature, date prepared, and months covered.
- Thirteen columns, one for each week in the quarter, are available to permit scheduling of maintenance requirements on a weekly basis throughout the quarter. Additional columns provide space to enter the complete MIP codes and any PMS requirements that may be required to be rescheduled into the next quarter. Take care to ensure that rescheduling changes conform to the periodicity specified for the requirement.

Preparation of the Quarterly PMS Schedule

Prepare OPNAV Forms 4790/14 or approved automated forms, in ink as follows:

1. Enter the workcenter code.
2. Enter the calendar year of the current quarter.
3. Enter the number of the quarter after overhaul as reflected on the Cycle PMS Schedule.
4. Enter the calendar months of the quarter as follows:

JAN/FEB/MAR

APR/MAY/JUN

JUL/AUG/SEP

OCT/NOV/DEC

- a. A ship ending a major overhaul, conversion, or construction in August would use the months of July, August, and September as the first quarter after overhaul. If the ship finished a major overhaul, conversion, or construction during the last 2 weeks in September, the first Quarterly PMS Schedule prepared

QUARTERLY PMS SCHEDULE (CONVENTIONAL)

OPNAV FORM 4790/14 (REV 6-73) S/N 0107-LF-3241

MIP	WORK CENTER	EA07	YEAR	94	QUARTER AFTER OVERHAUL	6	APPROVAL SIGNATURE	M. M. RODENT	DATE	30MAR94	RESCHEDULE		
	MONTH	APRIL			MAY			JUNE					
	4	11	18	25	2	9	16	23	30	6	13	20	27
2000/001-A2		X	2	6					18M-1			2M-6	
3000/001-73		X	X	X			M-1	M-2 M-4R			M-1	M-2 M-4R	
		2	3	2			A-2	2W-1	3W-2	2W-1		3W-2 2W-1	2W-1
								S-3R					
5210/009-C1								Q-5R(Q)				S-2	
5510/O18-82		X	X					M-1M-2				M-1M-2	
5530/001-13			X	X			M-1				M-1		
		X					Q-3						
		R											
				A									
5530/001-13		X						Q-2(M-1) S-1(R-1)			M-1		
		R					Q-3						
							A-13R						
4924/RHD-82			X	X				M-1M-2R				M-1M-2R	
		X					M-4		A-2	M-4			
		X					M-4			S-1	M-4		

ABE0711

Figure 7-11.—Quarterly PMS Schedule.

5. Each column represents a week and is divided into 7 days by the use of tick marks across the top. The first tick marked space within a column represents Monday. Place Monday's date for each week in the quarter on the pedestal between each column.
6. Lightly shade in across the tick marks the days that the ship expects to be underway.
7. Using both the LOEP and the Cycle PMS Schedule, enter the MIP number including the date code in the MIP column in a space on line with the subject equipment on the Cycle Schedule.
8. From the Cycle PMS Schedule, select the Schedule Quarter After Overhaul As Indicated column corresponding to the quarter being scheduled. Each of the maintenance requirements listed in this column and the Each Quarter column will be transcribed to an appropriate weekly column of the Quarterly PMS Schedule. If possible, do not schedule in the last 2 weeks of the quarter. These 2 weeks may then be used for rescheduled maintenance requirements.
9. Refer to the MIPs and the departmental master deck of MRCs for a brief description of the maintenance actions represented by the periodicity codes on the Cycle PMS Schedule to determine if the actions should be performed in port or at sea. Schedule the requirements on

the Quarterly PMS Schedule in the week most appropriate for accomplishment. With the exception of related daily and weekly PMS requirements, ensure that all mandatory related maintenance are scheduled within parentheses on the same line and during the same week as the primary maintenance requirement.

10. From the Cycle PMS Schedule column titled Each Quarter, schedule monthly, quarterly, and applicable situation requirements into the appropriate weeks of the Quarterly PMS Schedule. All calendar situation requirements (24M-2R, A-2R, S-IR, Q-3R, M-IR) must be accomplished at least once during the periodicity specified and also each additional time the situation arises. Schedule 2M() periodicity as indicated by a number in parentheses. For example, 2M(2) occur twice in the quarter (7 to 10 weeks apart).
11. From the Cycle PMS Schedule column, titled Schedule Quarter After Overhaul As Indicated, schedule the annual, semiannual, and multiple month requirements. Schedule the cycle requirements for which the number in parentheses matches the quarter after overhaul being scheduled.
12. Be sure that any PMS requirement listed in the Reschedule column of the previous Quarterly PMS Schedule is brought forward to the Quarterly PMS Schedule you are preparing.
13. The complete Quarterly PMS Schedule should be reviewed and then signed and dated by the department head in the appropriate block. If the ship's operating schedule changes significantly, PMS requirements scheduled in the affected periods may need to be reviewed and rescheduled as necessary to coincide with the new operating schedule.

Use of the Quarterly PMS Schedule

The Quarterly PMS Schedule serves as a directive to workcenter supervisors for scheduling weekly maintenance. Quarterly PMS Schedules are used as follows:

1. Each Monday, the division officer updates the previous week's column of the Quarterly PMS Schedule, using the following symbols:

X = Completed maintenance. The symbol X indicates completion of a maintenance

requirement. Fully accomplished MRs are addressed and X'd off separately on the Quarterly Schedule. Pay particular attention to make sure situation requirements that were accomplished are added and X'd off separately.

0 = Maintenance not completed. A circled requirement indicates a requirement that was not accomplished according to the applicable MRC.

ϕ = Satisfied by higher authority test. This symbol is used to mark scheduled equipment maintenance or lower level MRC requirements that have been satisfied by the completion of the parent system test. A brief explanation of the parent system test (including the MIP, who performed the maintenance, and when) is required on the reverse side of the Quarterly Schedule. An X marked over the higher level test symbol indicates that the lower level test requirement annotated with the ϕ has been satisfied. (MRCs that are so satisfied are identified on the applicable system level test MIP.)

2. The division officer is responsible for rescheduling circled requirements still within periodicity and for determining the reason for nonaccomplishment.
3. From the Quarterly PMS Schedule, the workcenter supervisor schedules the requirements for the following week on the Weekly PMS Schedule and updates the information in the Outstanding Repairs and PMS Requirements Due In The Next 4 Weeks column.
4. Any requirement that was not completed in strict accordance with the applicable MRC within its periodicity during the quarter must (in addition to being circled on the front of the Quarterly PMS Schedule) be identified on the back of the schedule by the complete MIP number and MRC code, followed by a brief reason for noncompletion. Example:

C-2/1 - 11 M-1 Unable to accomplish step I.J., "Test operate transmitter," due to antenna casualty. (This is an indication of a partial completion.) G-58/3-72 Q-1 Heavy seas preclude accomplishment as scheduled.

Unaccomplished S, A, or multiple-month periodicity requirements should be added to

the Reschedule column for accomplishment in the next quarter, if they are within their assigned periodicities. At the end of the quarter the department head should indicate awareness of the maintenance actions which were not accomplished by reviewing, signing, and dating the back of the schedule for the quarter just completed. The department head should also take positive steps to ensure that priority is given to completing maintenance requirements rescheduled from the previous quarter and those not accomplished within their assigned periodicities.

5. The completed Quarterly PMS Schedule is removed from the holder after the close of each quarter and retained as a planned maintenance record. The four previously completed quarterly schedules will be retained.
6. The recopying of Quarterly Schedules to facilitate legibility is discouraged, and should only be done with the division officer's written approval.

WEEKLY PMS SCHEDULE

The Weekly PMS Schedule (fig. 7-12) displays the planned maintenance scheduled for accomplishment in

WEEKLY PMS SCHEDULE (CONVENTIONAL)

OPNAV FORM 4790/15 (3-71) #U.S. GPO: 1982-508-678
 S/N 0107-LF-770-3260

WORK CENTER			PMS SCHEDULE FOR WEEK OF					APPROVAL SIGNATURE		OUTSTANDING REPAIRS & PM CHECKS DUE IN 4 WKS
MIP	COMPONENT	MAINTENANCE RESPONSIBILITY	MONDAY	TUESDAY	WEDNESDAY	THURSDAY	FRIDAY	SAT - SUN		
EA07			2-9 MAY					W.M. Smith		
2000/001	MACH LUB OIL NO.1 AMR								R-1	
3000/001	MISC SHIPBOARD ELECT EQUIPMENT								M-1 M-4R, R-2, S-4R	
	RECEPTACLES EGL-1	OVERTURF		2W-2	3W-1				2W-1, 3W-2	
	RUBBER GLOVES EGL-1								S-3R, R-1	
5210/009	FIREMAIN & FLUSHING	STERLING							Q-5R#, Q-1	
5510/018	COMPRESSED AIR SYSTEM EA07-001	HOYLE	D-1	D-1	D-1	D-1	D-1	D-1/D-1	M-1, M-2 A-5R, R-1, R-5W	
5530/001	O2N2 SYSTEM FWD 1-30-6								Q-1(*M-1)	
	PUMP 27345	PADGETT	Q-3						R-16D, R-17W	
	VALVES EGL-1	GALLE	W-1R D-1R	A-13R D-1R	D-1R	D-1R	D-1R	D-1R D-1R	A-13R, R-11M, D-1R, W-1R	
	VALVES EGL-2	HDOFA	W-1R D-1R	D-1R	D-1R	D-1R	D-1R	D-1R D-1R	D-1R, W-1R	
5530/001	O2N2 SYSTEM AFT 1-240-7								M-1	
	PUMP 26439	RUHNKE	Q-3						R-16D, R-17W	
	VALVES EGL-1								A-13R, R-11M	
	VALVES EGL-2	McCLURE	W-1R						D-1R, W-1R	
4924/RHD	LSD HUD MR3 MOO0	JACK	W-1						M-2R, R-1R	
	#1 HUD								R-1, M-1	
	#2 HUD								R-2, M-1	
6641/005	VENT DUCTS EGL-1								S-11R#	
	FILTERS								M-9	
	VENT DUCTS EGL-2								S-41R#	

UPDATE THIS SCHEDULE DAILY

ABE0712

Figure 7-12.—Weekly PMS Schedule.

a given workcenter during a specific week. A Weekly PMS Schedule is posted in each workcenter and used by the workcenter supervisor to assign and monitor the accomplishment of required PMS tasks by workcenter personnel.

Content of the Weekly PMS Schedule

The Weekly PMS Schedule contains the following information:

1. Workcenter code
2. Date of current week
3. Division officer's approval signature
4. MIP number (minus the date code)
5. A list of applicable components/equipment
6. Maintenance responsibilities assigned, by name, to each line item of equipment
7. The periodicity codes of maintenance requirements to be performed, listed by columns for each day
8. Outstanding major repairs, applicable PMS requirements, and all situation requirements

Preparation of Weekly PMS Schedule

Prepare the Weekly PMS Schedule as follows:

1. Using OPNAV Form 4790/15 or approved automated form, type in or neatly enter in ink the following basic (permanent) information from the Cycle PMS Schedule, the LOEP, and applicable MIPs:
 - a. Workcenter identification.
 - b. MIP codes and component nomenclature, line for line, to match the Cycle PMS Schedule. (Include serial or identifying numbers and EGL information if applicable.)
 - c. Daily and weekly PMS requirements as indicated in the MIPs for each workcenter. List all weekly requirements in the MONDAY column and daily requirements once in each day of the week column and twice in the SAT.-SUN. column. Schedule 2D periodicity on Monday, Wednesday,

Friday, and once in the SAT.-SUN. period. Schedule 3D periodicity on Monday, Thursday, and once in the SAT.-SUN. period.

- d. List all situation requirements in the Next Four Weeks column, and schedule them, as the situation requires. Also list the 2W periodicity requirements in the Next Four Weeks column.
 - e. Now, either laminated or covered with plastic so that it can be cleared and updated each week.
2. The following information is not permanent in nature and is written in after the schedule is laminated.
 - a. Using the Quarterly PMS Schedule, the workcenter supervisor transposes all PMS requirements from the column for the week being scheduled to the Weekly PMS Schedule. MIPs/MRCs must be reviewed to ensure that related maintenance actions are scheduled for the same day and that appropriate consideration is given to the week's operating schedule.
 - b. Using information from the Quarterly PMS Schedule, the workcenter supervisor lists in the Next Four Weeks column of the Weekly PMS Schedule all PMS requirements due in the next 4 weeks.
 - c. The workcenter supervisor assigns personnel, by name, to specific line entries.
 - d. The Weekly PMS Schedule is signed and dated by the division officer prior to its posting in the holder in the workcenter.

Use of the Weekly PMS Schedule

The Weekly PMS Schedule is used by the workcenter as follows:

1. Maintenance personnel obtain PMS assignments from the Weekly PMS Schedule and report completed and uncompleted maintenance actions to the workcenter supervisor.

2. When satisfied that the work has been properly completed, the workcenter supervisor crosses off, with an X, the maintenance requirement. If the maintenance is not completed, the maintenance requirement is circled and rescheduled. However, if material deficiencies or casualties that are unrelated to the maintenance requirement are discovered, the maintenance requirement can be X'd off, but the discrepancy must be reported to the workcenter supervisor. PMS requirements (other than daily checks) accomplished during the prescribed week but not on the day specified are considered completed on schedule and X'd off.
3. Each Monday morning, the division officer compares the preceding week's Weekly PMS Schedule with the Quarterly Schedule and ensures that the Quarterly Schedule is properly updated as follows:
 - a. Scheduled requirements that were completed are X'd out.
 - b. Scheduled requirements that were not completed are circled.
 - c. Situation requirements that occurred and were completed are entered and X'd off.
 - d. Requirements that were completed ahead of schedule are circled, back scheduled and X'd out.
4. Each Monday morning, the division officer reviews the current week's Weekly PMS Schedule, ensures that it is properly made out according to the Quarterly Schedule, and signs and dates the Weekly Schedule in the appropriate block.

REVIEW QUESTIONS

- Q4. *What maintenance requirements do the cycle schedules display?*
- Q5. *All superseded cycle schedules are retained for how many months?*

- Q6. *How often is the quarterly schedule updated?*

THE MAINTENANCE DATA SYSTEM

LEARNING OBJECTIVES: State the purpose of the Maintenance Data System and describe the types of maintenance actions reported on the following OPNAV forms: 4790/2K, 4790/CK, 4790/2P.

The Maintenance Data System is used to record information considered necessary for workload planning and coordination and to provide a data base for evaluating and improving equipment installed in the fleet. Much of the data collected by MDS returns to the ship in the form of a material history known as the Current Ship's Maintenance Project (CSMP).

Nearly all the reporting of maintenance actions other than normal PMS actions is done on a single multipurpose form, the Ship's Maintenance Action Form, OPNAV 4790/2K. Personnel completing a maintenance action fill out the appropriate sections of the form and send it via the ship's data collection center to an ADP (automatic data processing) facility to be processed. The 4790/2K contain information on the reporter's ship, workcenter, equipment worked on, and initial symptoms observed. In other sections, space is provided to record completion information, deferral of the work for various reasons, remarks, and special information for work requests. A space also exists for recording time meter and counter readings where they are required.

Normally, the following types of maintenance actions will be reported on the 4790/2K: system or equipment repairs or improvements; maintenance actions that require the use of parts or materials specifically requisitioned for the job; actions that cannot be completed in the usual amount of time due to the ship's operations; requirements for outside assistance, or unavailability of parts or material; assistance received from nonreporting activities, such as mobile technical training units (MOTUs) or technical representatives; major work associated with corrosion control and preservation of the ship; and certain PMS actions listed in the *3-M Manual*, OPNAVINST 4790.4.

To prevent the loss of significant data when it is recorded on several forms, each maintenance action must be assigned a unique identifier. Under MDS, this identifier is known as the job control number (JCN). It consists of a five-character unit identification code (UIC), a four-character workcenter code, and a four-character serial number called the job sequence number (JSN). Figure 7-13 shows an example of a JCN log used to record the JSNs. This system gives a workcenter at least 9,999 JCNs. If additional JCNs are desired, letters can be substituted for the first numeral. In any event, take care to make sure that two different jobs are not assigned the same JCN.

There are many different situations that could be covered by the MDS documents. This text will cover only the basic actions.

SHIP'S MAINTENANCE ACTION FORM (OPNAV 4790/2K)

The ship's maintenance action form (OPNAV 4790/2k) (fig. 7-14), printed on a single sheet of "no-carbon-required" paper, is the basic MDS document. If multiple copies are needed, the necessary number of forms may be fastened together and filled in at one time. The form may also be reproduced on electrostatic (Xerox-type) copying machines.

This form contains six sections that require entries to describe the type of maintenance action being reported. Entries should be printed in capital letters. All entries must be legible and should be inserted within the tic marks. If an error is made, it should be lined out using a single line, and the correct information entered.

SHIP'S FORCE WORK LIST (SFWL) & JOB SEQUENCE NUMBER (JSN) LOG

UIC:				WORK CENTER:				DESCRIPTION	STATUS OF REPAIR	SUPPLY 1250-1 (OR 1348 REQ NUMBERS)	LPO INIT	DEFERRED ACTION DEFER DATE (26)	REMARKS
JCN	EQUIPMENT ROOM NAME	PRIORITY 1 2 3 4	TYPE AVAILABILITY	DATE	ENTERED BY	TAG-OUT REQUIRED YES NO	2 LINA USED YES NO						

OPNAV 4790/2K (1-84)

ABEF0713

Figure 7-13.—Example of an job control number log.

SHIP'S MAINTENANCE ACTION FORM (2-KILO)

COMP DEF

SECTION I. IDENTIFICATION	JOB CONTROL NUMBER													
	1. SHIP'S UIC	2. WORK CENTER	3. JOB SEQ. NO.	4. APL/AEL										
A. SHIP'S NAME				5. EQUIPMENT NOUN NAME				6. WND	7. STA	8. CAS	9. DFR	10.	11.	12.
B. HULL NUMBER				13. IDENT/EQUIPMENT SERIAL NUMBER				14. EIC						
15. SAFETY HAZARD				16. LOCATION (Compartment, Deck, Frame, Side)				17. WHEN DISCOVERED DATE						
18. ALTERATIONS (SHIPALT, ORDALT, Fld Chg, etc.)				19. "I"		20. INSURV NUMBER		21. SUFFIX		22. U	23. S	24. P/F		

SECTION II. DEFERRAL ACTION	25. S/F MHRS. EXP.	26. DEFER. DATE	27. S/F MHRS. REM.	28. DEADLINE DATE
	0020	40 DAY 1	0017	40 DAY 1

SECTION III. COMPLETED ACTION	FOR SELECTED EQUIPMENTS ONLY				
29. ACT. TKN.	30. S/F MHRS.	31. COMPLETION DATE	32. ACT. MAINT. TIME	33. TI	34. METER READING

SECTION IV. REMARKS/DESCRIPTION

35. REMARKS/DESCRIPTION

SAFETY VLV B OPERATING ERRATIC INDICATING A BENT VLV SPINDLE. XXX REMOVE SAFETY VLV DELIVER TO IMA DISASSEMBLE AND INSPECT. REPAIR VLV AND TEST. SHIP PICKUP VLV RE-INSTALL AND TEST INOPERABLE SAFETY VLV BOILER MAY BE OVER PRESSURIZED.

37. CSMP SUMMARY

SAFETY VLV B SPINDLE BENT

38. FIRST CONTACT/MAINT. MAN (Print)	39. RATE	40. SECOND CONTACT/SUPERVISOR (Print)	41. P1	42. T2	43. INTEGRATED PRIORITY	SCREENING						
J. LINGO	BTC	D. HAMMOND										
C. DIV. INIT.	D. DEPT. INIT.	E. COMMANDING OFFICER'S SIGNATURE			F. TYCOM AUTHORIZATION		44. IUC	45. TYCOM				
D.M.	L.R.	C.E. PARKER, CDR, USN										
46. SPECIAL PURPOSE	A.	B.	C.	D.	E.	F.	G.	H.	I.	J.	K.	L.

SECTION V. SUPPLEMENTARY INFORMATION

47. BLUEPRINTS, TECH. MANUALS, PLANS, ETC.	48. PREARRIVAL/ARRIVAL CONFERENCE ACTION/REMARKS
NS - 351 - 0664	

SECTION VI. REPAIR ACTIVITY PLANNING/ACTION

49. REPAIR W/C	50. EST. MHRS.	51. ASST. REPAIR W/C	52. ASST. EST. MHRS.	53. SCHED. START DATE	54. SCHED. COMP DATE
				YR DAY	YR DAY
55. REPAIR ACTIVITY UIC	56. WORK REQ. ROUTINE	57. EST. MANDAYS	58. EST. MANDAY COST \$	59. EST. MATERIAL COSTS \$	
60. EST. TOTAL COST \$	61. JOB ORDER NUMBER		62. LEAD P&E CODE	63. DATE OF EST. DAY	
64. FINAL ACT.	65. MHRS. EXPENDED	66. DATE COMPLETED	G. COMPLETED BY (Signature - Rate)		H. ACCEPTED BY (Signature - Rate/Rank)
	YR	DAY			

ABEF0714

Figure 7-14.—Ship's Maintenance Action Form (OPNAV 4790/2K).

The OPNAV 4790/2K is used to report all deferred maintenance actions and the completion of maintenance actions that do not result in configuration changes. Partially completed maintenance actions that will result in configuration changes and complete or partial accomplishment of alterations are reported on OPNAV 4790/CK. A description of the OPNAV 4790/2K information sections is presented in the following paragraphs.

Section I-Identification

This section identifies the equipment or system on which maintenance actions are being performed.

Section II-Deferral Action

This section filled in when reporting the deferral of a maintenance action. Indicates ship's force man-hours expended up to the time of deferral, the date of the deferral, ship's force man-hours remaining, and if the work must be completed by a certain date.

Section III-Completed Action

This section is filled in to report the completion of a maintenance action.

Section IV-Remarks/Description

This section must be filled in when the deferral of a maintenance action is reported. It is filled in when the completion of a maintenance action is reported, only when such remarks are considered important to the maintenance action. This section must also be filled in to report maintenance actions on selected equipment requiring second level reporting, and to describe situations that are safety related.

Section V-Supplementary Information

This section contains helpful information about deferred maintenance actions, such as what technical manuals and blueprints are available and whether or not they are retained on board the requesting ship.

Section VI-Repair Activity Planning Action

The repair activity may use this section for internal planning and scheduling of the workload.

Block G, Completed By

This block contains the signature and rate/rank of the senior person actively engaged on the job in the lead workcenter. For maintenance actions not requiring assistance from an outside workcenter, the senior person working on the job signs this block and indicates his or her rate.

Block H, Accepted By

This block contains the signature and rate/rank of the individual authorized by the tended ship to verify the acceptability of the work performed. Completion of this block is mandatory when an OPNAV 4790/2K is used to report completion of a previously deferred maintenance action. For maintenance actions not requiring assistance from an outside workcenter, the workcenter supervisor will sign this block and indicate his or her rate/rank.

The commanding officer, or his/her authorized representative, places his/her signature on all original deferrals in block E. Two copies are held in a deferral suspense file in the workcenter until the JCN appears on the automated CSMP report, at which time the copies are transferred to the active suspense file held in the workcenter

MAINTENANCE PLANNING AND ESTIMATING FORM (OPNAV 4790/2P)

The maintenance planning and estimating form (OPNAV 4790/2P) (fig. 7-15) is used along with the OPNAV 4790/2K form for deferring maintenance to be done by an intermediate maintenance activity (IMA). Attached to the original 2K at the intermediate maintenance activity, it is used by the IMA to screen and plan the job in detail.

OPNAV 470/2P (6-94) **MAINTENANCE PLANNING & ESTIMATING FORM (P & E)**

SECTION I. PLANNING

A. SHIP'S NAME USS UNDERWAY		B. HULL NUMBER AS-48	JOB CONTROL NUMBER		
		1. SHIP'S UIC 20888	2. WORK CENTER EA05	3. JOB SEQ NO 2858	
4. PERIODIC MAINTENANCE REQUIREMENT		5. PERIODICITY	6. YMM ISSUED	7. SPECIAL DATA	

8. SCREENING ACTION a <input type="checkbox"/> IUC h <input type="checkbox"/> TYCOM DEPOT ACCOMPLISH b <input checked="" type="checkbox"/> I <input type="checkbox"/> IMA ACCOMPLISH c <input type="checkbox"/> J <input type="checkbox"/> TSU/NAVSEC/NOSSO/ETC. d <input type="checkbox"/> K <input type="checkbox"/> SHIP'S FORCE (IMA) (DEPOT) ASSIST e <input type="checkbox"/> L <input type="checkbox"/> SHIP TO SHOP f <input type="checkbox"/> M <input type="checkbox"/> ACCOMPLISH WITH MODIFICATIONS g <input type="checkbox"/> N <input type="checkbox"/> DISAPPROVE		9. QUALITY ASSURANCE REQUIREMENT a <input type="checkbox"/> SUBSAFE b <input type="checkbox"/> LEVEL 1 c <input type="checkbox"/> NUCLEAR LEVEL 1 d <input type="checkbox"/> NON-DESTRUCTIVE TEST e <input type="checkbox"/> NUCLEAR WORK PROCEDURES f <input type="checkbox"/> SUBMARINE ANTENNA ENGINEERING DIVISION g <input checked="" type="checkbox"/> SPECIAL CLEANING h <input checked="" type="checkbox"/> SPECIAL TESTING i <input type="checkbox"/> SPECIAL IDENTIFICATION j <input type="checkbox"/> NOISE CRITICAL k <input type="checkbox"/> RADIOLOGICAL CONTROL l <input checked="" type="checkbox"/> OTHER CONTROLS <p style="text-align: center;">HAZMAT</p>			10. SPECIAL REQUIREMENTS a <input type="checkbox"/> KEY EVENT b <input type="checkbox"/> SPECIAL INTEREST c <input type="checkbox"/> DRY DOCK REQUIRED d <input type="checkbox"/> PRE-OVERHAUL TEST REQUIRED e <input checked="" type="checkbox"/> POST-OVERHAUL TEST REQUIRED f <input type="checkbox"/> DEPARTURE TEST REQUIRED	
--	--	---	--	--	--	--

C. IUC SIGNATURE <i>WZEMOJF</i>	D. TYCOM SIGNATURE	11. NORMALLY DONE BY a <input type="checkbox"/> S/F b <input checked="" type="checkbox"/> IMA c <input type="checkbox"/> DEPOT
---	---------------------------	--

SECTION II. SCHEDULING

12 LEAD WORK CENTER 25A	13 SCHED START DATE YR DA 4053	14 SCHED COMP DATE YR DA 4068	15 EST MHRS 0083	16 KEY OP 02	17 TASK EVAC & RECHG
18 ASST WORK CENTER 03T	19 SCHED START DATE YR DA 4054	20 SCHED COMP DATE YR DA 4067	21 EST MHRS 0004	22 KEY OP 03	23 TASK UNSHIP & CLAD
24 ASST WORK CENTER 03A	25 SCHED START DATE YR DA 4051	26 SCHED COMP DATE YR DA 4069	27 EST MHRS 0049	28 KEY OP 01	29 TASK MONITOR FREON
30 ASST WORK CENTER 26A	31 SCHED START DATE YR DA 4056	32 SCHED COMP DATE YR DA 4057	33 EST MHRS 0006	34 KEY OP 04	35 TASK BRAZE/WELD
36 ASST WORK CENTER 51A	37 SCHED START DATE YR DA 4053	38 SCHED COMP DATE YR DA 4058	39 EST MHRS 0021	40 KEY OP 05	41 TASK REWIND & BAKE
42 ASST WORK CENTER	43 SCHED START DATE YR DA	44 SCHED COMP DATE YR DA	45 EST MHRS	46 KEY OP	47 TASK

SECTION III. TECHNICAL DOCUMENTATION

46 NAVSHIPS TECH MAN 351-0665	ON BOARD YES NO X

SECTION IV. IUC/REPAIR ACTIVITY/TYCOM REMARKS

49
COMPRESSOR MOTOR SHORTS

SECTION V. SUPPLEMENTAL PLANNING

50 EST MANDAYS	51 EST MANDAYS COST \$	52 EST MATERIAL COST \$	53 EST TOTAL COST \$	54
-----------------------	-------------------------------	--------------------------------	-----------------------------	-----------

ABE0715

Figure 7-15.—Maintenance Planning and Estimating Form (OPNAV 4790/2P).

SUPPLEMENTAL FORM (OPNAV 4790/2L)

The supplemental form (OPNAV 4790/2L) (fig. 7-16) is used by maintenance personnel to provide amplifying information (such as drawings and listings) related to a maintenance action reported on an OPNAV 4790/2K. The information on this form will never be entered into the computer. The form is prepared in the following manner:

1. The ship's name and hull number are entered in blocks A and B.
2. If the form is a continuation of a maintenance data form or another supplemental report form, the appropriate form is checked in block F and the JCN assigned to the basic form is entered in blocks C, D, and E.
3. Section II will contain comments, sketches, or other supplemental information.

OPNAV 4790/2L (Rev. 6-73) S/N 0107-LF-770-3060 **SUPPLEMENTAL FORM (2-LIMA)**

SECTION I. IDENTIFICATION		JOB CONTROL NUMBER		
A. SHIP'S NAME	B. HULL NUMBER	C. SHIP'S UIC	D. WORK CENTER	E. JOB SEQ. NO.
USS CHANDLER	DDG-996	21439	WD 01	0195
		F. CONTINUATION FOR <input checked="" type="checkbox"/> 2K <input type="checkbox"/> 2L <input type="checkbox"/> 2P		

SECTION II. REMARKS/SKETCHES

G.

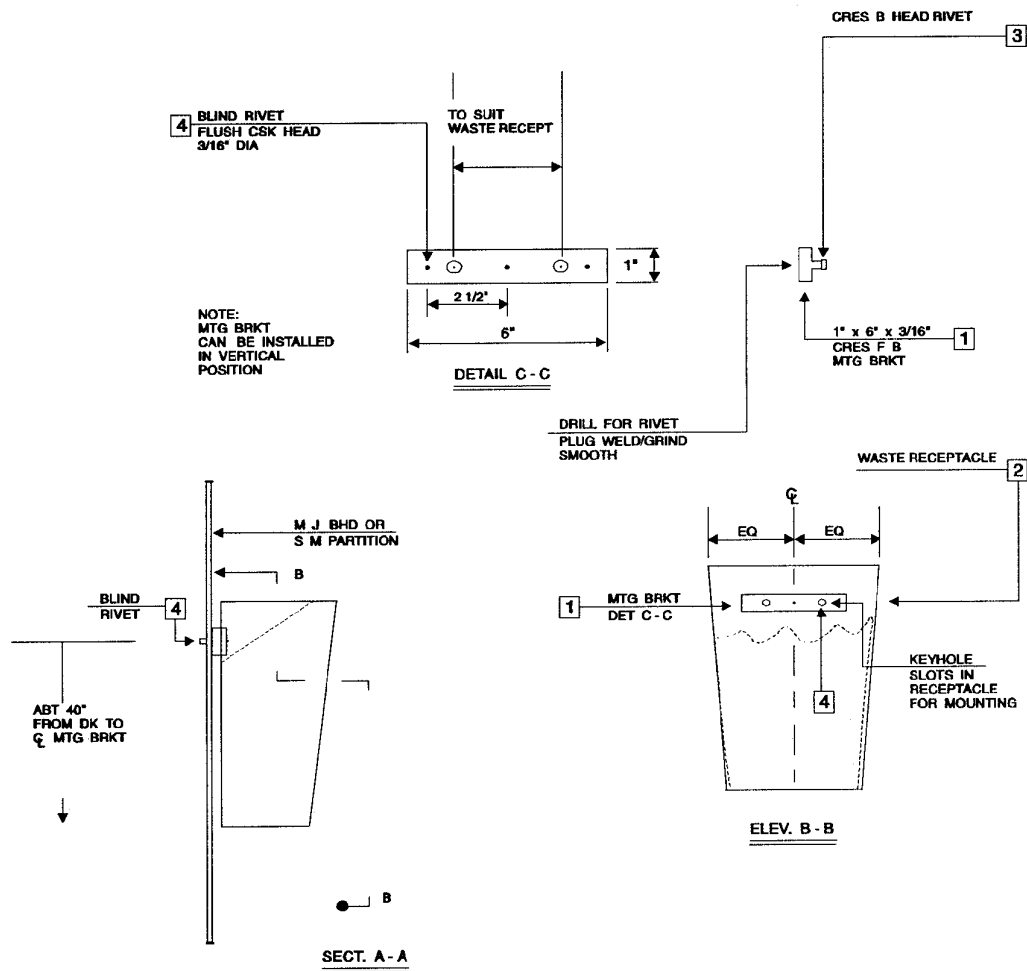

SECTION III. AUTHENTICATION			
H. FIRST CONTACT/MAINTENANCE MAN (Print)	I. DATE YR DAY	J. SECOND CONTACT/SUPERVISOR (Print)	K. DATE YR DAY
A. J. SWENEY, SN	3, 2, 0, 7	B. J. WALTERS, BMI	3, 2, 0, 7

ABE10716

* U.S. Government Printing Office: 1975-603-627/5225 2-1

Figure 7-16.—Supplemental Form (OPNAV 4790/2L).

4. Section III (blocks H, I, J, and K) will contain the names of the person and the supervisor submitting the report.

REPORTING CHANGES TO EQUIPMENT CONFIGURATION

One of the major objectives of the MDS is to provide the capability for reporting configuration changes. The importance of configuration change

reporting cannot be overemphasized. Whenever any system, equipment, component, or unit within the ship is installed, removed, modified, or relocated, the change must be reported. This action will ensure proper accounting of configuration changes, and will improve supply and maintenance support such as technical manuals, PMS coverage, and COSAL to the fleet. The Configuration Change Form (ONNAV 4790/CK) (fig. 7-17) is used to provide this service.

SHIP'S CONFIGURATION CHANGE FORM				OPNAV 4790/CK		CONFIG FILE CORR	COMP. M/A NO DEFL	COMP DEFL
SECTION I JOB IDENTIFICATION								
JOB CONTROL NUMBER			ALTERATION IDENTIFICATION					
1. SHIP'S UIC	2. WORK CENTER	3. JOB SEQ. NO.	4. ALTERATIONS (SHIPALT, ORDALT, FLD. CHG, etc.)					
20012	EXSA	B689	SALS D 28758 D					
A. SHIP'S NAME			B. HULL NUMBER		5. EIC		6. ACT. TAG	
USS PORTLAND			LSD37		TF 03		5 B	
5. EQUIPMENT NOUN NAME			8. S/F M/RS. EXP.		9. ACT. MAINT. TIME		10. COMP. DATE	
LP AIR COMPRESSOR			R0040		070		4030	
SECTION II JOB DESCRIPTION/REMARKS								
12. JOB DESCRIPTION/REMARKS								
REMOVED LP AIR COMPRESSOR PER SHIPALT DIRECTIVE								
SECTION III CONFIGURATION CHANGE IDENTIFICATION								
13. COMPONENT NOUN NAME						14. QUANTITY		15. CA
LP AIR COMPRESSOR						002		R
16. COMPONENT IDENTIFICATION			17. COMPONENT SERIAL NUMBER					
1 AND 2			NONE					
18. COMPONENT APL/AEL			19. LOCATION (DECK/FRAME/SIDE)			22. EIC		
061900511			3-110-0			TF03		
21. NEXT HIGHER ASSEMBLY						21. SAC		22. WORK CENTER
COMPRESSED AIR SYSTEM						OBAC		BEM07
24. NAMEPLATE DATA								
25. MIP								
A-004/003-A2				26. EOSS LPAC/000				
27. TM								
9241-AB-MMO-010								
SECTION IV. SPECIAL PURPOSE								
28. RIN			29. AILSIN			30. SECAS OFFICE USE		
B051055.153								
- INSTRUCTIONS -								
ITEM NUMBER	SECTION I & II DESCRIPTION	SECTION I & II			LEGEND			
		PAGE 1	CONT	PAGE	IA	O		
1-3	JOB CONTROL NUMBER	M		M	IA	O		
4	ALTERATION IDENTIFICATION	IP		IP	IP	NR		
5	EQUIPMENT IDENTIFICATION	M		NR	M	NR		
6	ACTION TAKEN	M		NR	M	NR		
7	EQUIPMENT NOUN NAME	M		NR	SECTION I, BLOCK 6 ACTION TAKEN			
8	SHIP'S FORCE MANHOURS	M		NR	SECTION III, BLOCK 15 COMPONENT ACTION			
9	ACTIVE MAINTENANCE TIME	M		NR	5A - PARTIALLY COMPLETED ALTERATION			
10	COMPLETION DATE	M		NR	5B - FULLY COMPLETED ALTERATION			
11	METER READING	IP		NR	5C - FULLY COMPLETED EQUIVALENT TO ALTERATION			
12	JOB DESCRIPTION (REMARKS)	O		NR	5D - ALTERATION DIRECTIVE NOT APPLICABLE			
13	COMPONENT NOUN NAME	M	R	M	1 - MAINTENANCE ACTION COMPLETED: PARTS			
14	QUANTITY	M	M	M	2 - MAINTENANCE ACTION COMPLETED: REQUIRED PARTS NOT DRAWN FROM SUPPLY (LOCAL MANUFACTURE, PRE-EXPENDED BINS)			
15	COMPONENT ACTION	M	M	M	3 - MAINTENANCE ACTION COMPLETED: NO PARTS REQUIRED			
16	COMPONENT IDENTIFICATION	IP	IP	IP	SHIP SEQUENCE NUMBER			
17	COMPONENT SERIAL NUMBER	IA	IA	IA	PAGE 1 OF 2			
18	COMPONENT APL/AEL	M	IA	IA				
19	LOCATION	M	M	M				
20	EQUIPMENT IDENTIFICATION CODE	NR	IA	NR				
21	NEXT HIGHER ASSEMBLY	IP	IP	IP				
22	SERVICE APPLICATION CODE	IA	IA	IA				
23	WORK CENTER	NR	M	NR				
24	NAMEPLATE DATA	NR	M	NR				
25	MAINTENANCE INDEX PAGE	IA	IA	IA				
26	EOSS	IP	IP	IP				
27	TECHNICAL MANUAL NUMBER	IA	IA	IA				

Figure 7-17.—Ship's Configuration Change Form (OPNAV 4790/CK).

The OPNAV 4790/CK form is completed to the maximum extent possible by the accomplishing activity and provided to the ship or activity 3-M coordinator.

The 3-M coordinator then reviews the forms for legibility (all copies) and completeness and provides the forms to the applicable workcenter supervisor, who ensures that the proper documentation is completed and processed when a configuration change is accomplished, including required signatures to indicate verification of all reported configuration changes.

The ship is also responsible for reporting and monitoring all changes accomplished by ship's force during any type of availability, and for providing the Configuration Change Form to the overhauling activity. The ship is not responsible for reporting configuration changes accomplished by an overhauling activity during availabilities.

A configuration change is either (1) the accomplishment of any action prescribed by an alteration directive (SHIPALT or equipment alteration) or (2) the installation, removal, or modification of any system, equipment, component, or unit. The replacement of repair parts (such as nuts, bolts, wires, O-rings, gaskets, resistors, and capacitors) with like parts, does not constitute a configuration change.

The OPNAV 4790/CK form is used to report a configuration change or to report the completion of a previous deferral that resulted in a configuration change. Deferred maintenance actions and completed maintenance actions that do not result in configuration changes are reported on OPNAV 4790/2K. The OPNAV 4790/2K form will never be used to report accomplishment of any maintenance action that results in configuration changes.

A configuration change occurs whenever the accomplishment of a maintenance action results in the following:

- Addition or installation of any new equipment.
- Deletion, removal, or turn-in of any installed equipment.
- Replacement or exchange of any equipment. A replacement or exchange is reported as the removal of an installed item of equipment and the installation of a new item of equipment.

- Modification of any installed or in-use equipment. A modification occurs when a maintenance action alters the design or operating characteristics of the equipment or when nonstandard replacement parts (not identified on the APL or in the technical manual) are used.
- Relocation of any equipment to a new deck, new frame, or new compartment.
- Accomplishment of any alteration directive, such as a field change or SHIPALT.

CAUTIONS ON ERRORS

Since the data entered on the MDS forms is used by data processing equipment to provide information to a ship in the form of the CSMP report, it is essential that each form be filled in completely and accurately. A computer cannot recognize anything that it is told does not exist. It will reject incorrect and incomplete entries and the data will not be available for use. To prevent this from happening, it is important that the completed forms be reviewed at all levels. Some of the common errors that workcenter supervisors, division officers, department heads, and 3-M coordinators should be alert for are

- omission of slash marks through zeros and Z's;
- incorrect EICs;
- use of improper codes for alterations and field changes;
- too many or not enough spaces between words in the Remarks section;
- incorrect dates; and
- incorrect entries.

These are only a few of the many errors detected each day by a typical TYCOM 3-M staff section.

Some areas on the 4790/2K require special mention. Alterations and field changes are identified in block 18 by a two-letter code in the first two spaces, followed by the identification number of the change. A title code, such as A, D, F, or K may be shown in the authorizing directive of SHIPALTs. This title code, if assigned, must be entered in the extreme right hand position of the block.

In block 18, the first two letters identify SHIPALT (SA), ORDALT (OA), field change (FC), or any other appropriate instruction. Electronic equipment is always identified by serial number, and only one piece of equipment may be reported under a given JCN. If several pieces of the same type of equipment are altered by field changes, there must be one document for each piece of equipment. Example:

A ship has four C-13 Mod 1 catapults, and field change 17 is to be installed in all of them. Each catapult will be changed, and the changes will be reported on separate documents showing a specific JSN and equipment serial number. This will enable the computers to identify which items of equipment have been changed and which have not. It also will be reflected on the readouts returned to the ship as part of its material history.

Another problem is the use of the noun name in block 5. For electronic equipment the "AN" designation is the best entry for the noun name. If there is no "AN" designation, the name from the nameplate should be used. Up to 16 characters of a name may be entered.

In block 35, a space follows each word, and words that cannot be completed on a line are continued on the next line with no spaces or hyphens inserted. On deferred actions, the XXX's used to separate the trouble from the desired corrective action must not be separated. If they cannot be fitted in on one line, extra spaces will be left blank on that line and the XXX's will be put in the first spaces of the next line.

REVIEW QUESTIONS

- Q7. *Maintenance Data System is used to record what type of information?*
- Q8. *Under the maintenance Data System, what is a Job Control Number?*
- Q9. *What is the OPNAV 4790/2K used to report?*
- Q10. *The OPNAV 4790/2P provide what type of information?*

SUPPLY

LEARNING OBJECTIVES: Recognize the different types of stock and control numbers. Recall the purpose of cognizance symbols. Recognize sources of identifying material when a stock number is not available. Recognize the uses of the following supply

publications: FED LOG, ML-C, MCRL, MRIL, ASG, and GSA.

One of the duties of an ABE is to identify and requisition material. This section provides basic information to help you develop the knowledge you need to perform these duties. Proper material identification is essential to the requisitioning and receipt of the correct item. You must understand the terminology used in material identification.

GENERAL INFORMATION

Material is managed according to category (Federal Supply Classification) and its intended use. An inventory manager is assigned for each category of material, and has overall responsibility for all items within the category. All items in the supply system have an assigned two-position cognizance symbol code. This code identifies the inventory manager and the stores account in which the material is carried. The items assigned to bureau, office, or systems command for inventory management includes the following material:

- Material in the research and development stage
- Material that requires continuing logistics, engineering, or fiscal administration and control at the department level.
- Material recognized as a onetime installation that was bought and issued for a specific use

Naval Supply System Command (NAVSUP) Inventory Control point (ICP) items are those for which bureau, office, or systems command management is not essential. The NAVSUP ICP provides stocks of these items to its segment of the supply system. This group of items includes equipment, repair parts, and consumables. It also includes those items for which stocking determination, quality control, funding, and issue control can be accomplished by the ICP if required, the ICP ensure that these items are available from commercial sources and other government agencies. NAVSUP selects the items assigned to ICP for inventory management with the advice of the appropriate bureau, office, or systems command.

The Navy Retail Office items are items for which joint military supply management responsibility is vested to the Defense Logistics Agency (DLA). These items include components, repair parts, consumables, and other material. The requirement determination and procurement of these items can be accomplished by the

defense supply center on a combined basis for all military services.

MATERIAL CATALOGING AND CLASSIFICATION

LEARNING OBJECTIVE: Recognize the different types of stock and control numbers. Recall the purpose of cognizance symbols. Recognize sources of identifying material when a stock number is not available. Recognize the uses of the following supply publications: MCRL, ML-C, MRIL, ASG, and GSA.

This will help you understand the information used in material identification. There are more than 4 million supply items in the Department of Defense (DOD) supply system. The Navy supply system alone stocks more than 1 million items. Each item must be identified to make buying, stocking, and issuing easier. To accomplish this, each item must be listed in different groups or categories.

FEDERAL CATALOG SYSTEM

The Federal Catalog System encompasses the naming, description, and numbering of all items carried under centralized inventory control by the Department of Defense (DOD) and civil agencies of the Federal Government as well as the publication of related identification data. Only one identification may be used for each item in all supply functions from purchase to final disposal. The North Atlantic Treaty Organization (NATO) countries also use the Federal Catalog System. The Defense Logistics Agency (DLA) administers the Federal Cataloging System under the direction of the Assistant Secretary of Defense (Installation and Logistics).

FEDERAL SUPPLY CLASSIFICATION SYSTEM

The Federal Supply Classification (FSC) System was designed to permit the classification of all items of supply used by the Federal Government. Each item of supply is classified in only one four-digit Federal Supply Classification class. The first two digits denote the group or major division of commodities within the group. Currently, there are 76 groups assigned. Group numbers start from 10 and end at 99. Table 7-3 is an example list of federal supply groups and titles.

Table 7-3.—Example List of Federal Supply Groups

GROUP	TITLE
17	Aircraft launching, landing, and ground handling equipment
48	Valves
53	Hardware and abrasives

The number of classes within each group varies. Each class covers a particular area of commodities according to physical or performance characteristics. The items in the class are usually requisitioned or issued together. This is used as a basis for including items in the same area of commodities. Examples of how classes are used to divide types of material within a stock group are shown in figure 7-18. The stock group and class together make the Federal Supply Classification (FSC).

GROUPS	CLASSES
Group 17 Aircraft launching, landing, and ground handling equipment	1710 Arresting gear and barricade equipment
	1720 Catapult launching equipment
Group 48 Valves	4810 Valve solenoid
	4820 Valve angle
Group 53 Hardware and abrasives	5305 Screws
	5306 Bolts
	5307 Studs
	5310 Nuts and washers
	5320 Rivets

Figure 7-18.—Examples of supply classes within a stock group.

The Navy uses groups 01 through 09 for forms and publications that are not included in the Federal Catalog System. The forms and publications are numbered according to the following system:

- 01 Navy Department forms
- 02-08 Publications
- 09 District and fleet forms

NATIONAL STOCK NUMBER (NSN)

All items of supply that are centrally managed or bought for system stock are required to have a National Stock Number (NSN) assigned to them. National Stock Numbers are used in all supply management functions and publications that mention the items. The NSN is a 13-digit number assigned by Defense Logistics Information Service (DLIS) to identify an item of material in the supply distribution system. The following paragraph discusses the breakdown of an NSN. Figure 7-19 is an example of an NSN.

Federal Supply Classification (FSC)

The Federal Supply Classification (FSC) is a four-digit number that occupies the first part of an NSN. The Defense Logistics Agency Cataloging Handbook H2 (in book form) lists the groups and classes in use today.

National Codification Bureau (NCB) Code

The National Codification Bureau (NCB) code is a two-digit code that occupies the fifth and sixth position of a NATO stock number. These code identifies the NATO country that originally cataloged the item of supply. The NCB codes currently assigned are listed in *Afloat Supply Procedures*, NAVSUP P-485. The NSN assigned by United States uses NCB codes “00” and “01.”

National Item Identification Number (NIIN)

The National Item Identification Number (NIIN) consists of a two digit National Codification Bureau (NCB) code and seven digits which in conjunction with the NCB code, uniquely identify each NSN item in the federal supply distribution system. In the example given in figure 3-2, the “00-1234567” is the NIIN. Although part of the NSN, NIINs are used independently for material identification. Except for identification list, most federal supply catalogs are arranged in NIIN order.

In addition to the 13-digit NSN, the Navy uses other codes for material identification. These codes may be prefixes or suffixes to the NSN. The following paragraphs describe these codes.

Cognizant (COG) Symbol

The cognizant (COG) symbol consists of a two-character code that identifies the stores account and cognizant inventory manager of an item. The cognizant symbols are listed in table 7-4. To understand cognizant symbols, you must understand the following terms:

Stores Account: This is an account reflecting the value of material, supplies, and similar property on hand. The accounts are the Appropriation Stores Account (APA) and the Navy Stock Account (NSA).

Appropriations Purchase Account (APA): This account is for all stock material paid for out of appropriations. This material is not charged to the user’s operating funds. If the material was ought for a purpose other than its original appropriation, the material is chargeable to the user’s fund.

Navy Stock Account (NSA): The NSA consists of all material paid from the Defense Business Operating Fund (DBOF). NSA material is always charged to the user’s allotment, operating budget, or operating target funds.

Inventory manager: This is an organizational unit or activity within the Department of Defense. The inventory manager has the primary responsibility for controlling the functions of cataloging, identification, determination of requirements, procurement, inspection, storage, and distribution of categories of material.

Technical responsibility: This is the systems command or office that determines the technical characteristics of equipment. For example, the electronics equipment characteristics include items such as circuitry and the types and arrangement of components.

1710	00	1234567
Federal Supply Classification Code Number	National Codification Bureau Code	National Item Identification Number

Figure 7-19.—Example of an NSN.

Expense type item: This term identifies stock items that are financed by the Defense Business Operating Fund, and is the same as NSA items.

Consumable: Consumable material is material that is consumed in normal use. Some of the examples of these materials are paints, cleaning supplies, office supplies, and common tools.

Table 7-4.—Cognizance (COG) Symbols

COG SYMBOL	COGNIZANT INVENTORY MANAGER	STORES ACCOUNT	TECHNICAL RESPONSIBILITY	DEFINITION
0I	Naval Publication and Forms Directorate	None	Navy Publication and Printing Service	Publications
1I	Naval Publication and Forms Directorate	NSA	Navy Publication and Printing Service	Forms
1R	Naval Inventory Control Point Philadelphia (NAVICP PHIL)	NSA	Naval Air System Command	Aeronautical, photographic, and meteorological 1 material (consumable or expense type material).
4R	Naval Inventory Control Point Philadelphia (NAVICP PHIL)	APA	Naval Air System Command	Catapult and arresting gear material (repairable or investment type material).
4V	Naval Air System Command	APA	Naval Air System Command	Aircraft engines.
4Z	Naval Inventory Control Point Philadelphia (NAVICP PHIL)	APA	Naval Air System Command	Airborne armament.
5R	Naval Inventory Control Point Philadelphia (NAVICP PHIL)	NSA	Naval Air System Command	Catapult and arresting gear material (consumable or expense type material).
6R	Naval Inventory Control Point Philadelphia (NAVICP PHIL)	APA	Naval Air System Command	Aviation ground support equipment (repairable or investment type material).
6V	Naval Air System Command	APA	Naval Air System Command	Technical directive change kits.
7R	Naval Inventory Control Point Philadelphia (NAVICP PHIL)	NSA	Naval Air System Command	Depot-level repairable aviation material.

Cognizance symbols are two-character, alphanumeric codes prefixed to national stock numbers. Cognizance symbols are listed in Table 7-4. The first character of the cognizance symbol identifies the stores account. The following information refers to the first character of the cognizance symbol:

- Cognizance symbols 0 (zero), 2A and 8A is not carried in the stores account and is issued without charge to the requisitioner.
- Even numbers 2, 4, 6, and 8 are carried in the Appropriation Stores Account (APA).
- Odd numbers 1, 3, 5, and 7 are carried in the Navy Stock Account (NSA).
- Number 9 is Navy-owned material carried in NSA and managed-by the Naval Inventory Control Point Mechanicsburg.

The second position of the cognizance symbol identifies the item manager. The item manager exercises supply management over specified categories of material.

Material Control Codes

A Material Control Code (MCC) is a single alphabetic character assigned by the inventory manager. It is used to segregate items into manageable groupings (fast, medium, or slow movers) or to relate to field activities special reporting and control

requirements. Table 7-5 contains a list of MCCs commonly encountered.

NAVY ITEM CONTROL NUMBER (NICN)

As we have discussed in a previous paragraph, NSNs are required for all items centrally managed or bought for supply system stock. With changes of equipment and products, the Navy buys new items from the suppliers. New items entering the Navy supply system are identified in time to permit assignment of NSNs before shipment. In numerous instances, the Navy Item Control Number (NICN) is used to identify the items before an NSN can be assigned. Some items are permanently identified by the NICN because of the nature of the items. The NICN designation includes the following:

- Inventory Control Point ICP control numbers
- Kit numbers
- Publications and forms ordering numbers
- Local Navy Activity Control (NAC) numbers
- Other locally assigned numbers

The NICN is a 13-digit number that identifies an item of supply. It is composed of the following parts:

- Federal Supply Classification (FSC) code (numbers that occupy the first four digits of the NICN)

Table 7-5.—Material Control Codes

CODE	DEFINITION
D	Field level repairable.
E	(1) Depot-level repairables. (2) Material (expendable ordnance) requiring lot and serial number control, but is reported by serial number only.
H	Depot-level repairables.
L	Items of local stock or items pending NSN assignment.
M	Medium demand velocity items (consumables).
S	Slow demand velocity items.
T	Terminal items.
W	Ground support equipment.
X	Special program repairables.
Z	Special program consumables.

Table 7-6.—Navy Item Control Codes

NIC NUMBER CODES	USED TO DESIGNATE
LD	Directive ordering number (COG 0I). Example: 1234-LD-123-4567
LF	Form ordering number (COG 1I). Example: 1234-LF-123-4567
LK	Aircraft change kit number. Example: 1234-LK-123-4567
LP	Publication ordering number (COG 0I and 0P). Example: 1234-LP-123-4567
LX	Control number assigned by NAVICO PHIL field activities to certain items under their inventory control. Example: 1234-LX-123-4567

- Navy Item Control Number (NICN) code (letters that occupy the 5th and 6th position)
- Serial number (alphanumeric and occupies the 7th through the 13th position)

The NIC numbers that you must be familiar with are listed in Table 7-6. These codes differentiate the types of NICN.

Permanent LL Coded NICNs

The NICNs with “LL” in the 5th and 6th positions and a “C” in the 7th position mean that the ICPs or other Navy item managers (including field activities) assigned them. Its purpose is to identify and monitor nonstocked items that are not expected to have enough demand to qualify for NSN assignment. The NICNs are assigned to permit the maintenance of a complete and uniform inventory control point weapons system file. It is also used to ensure that selected items are considered for inclusion in future allowance lists. Stock points must purchase items identified by this type of NICN. Stock points currently do not have the capability to translate permanent LL coded NICNs to applicable CAGES and part numbers. The items are requisitioned

by using the DD 1348-6 format (part number requisition).

Temporary LL Coded NICNs

The NICNs with “LL” in the 5th and 6th positions and any letter except “C” in the 7th position are assigned by ICPs or other Navy inventory managers for temporary identification. These NICNs enables the item manager to establish and maintain automated file records, to ease procurement action, and to maximize automated processing of requisitions. The cognizant item managers review the temporary NICNs periodically to convert them to NSN or to delete the ones that are no longer required. When a requisition identifies an item by a temporary NICN that has been converted to an NSN the status card will include the new NSN. A NICN to NIIN cross-reference list is published monthly by the Defense Logistics Information Service (DLIS) on the FED LOG CD-ROM.

LOCAL ITEM CONTROL NUMBER (LICN)

The LICN (fig. 7-20) is an identification number assigned by an activity for its own use. However,

1710	LL	0000123
Appropriate Federal Supply Classification Code Number	Designation for locally assigned identification number	Serially assigned identification number

Figure 7-20.—Example of an LICN.

LICNs are not authorized in supply transaction documents. LICNs are for local use only and may be assigned to shipboard stocked consumable items that are not identified by and NSN or another type of NICN. A LICN consists of 13 characters. The first four will be numbers corresponding to the federal supply classification (FSC) of a similar NSN items, the fifth and sixth will be LL and the remaining seven alpha numeric.

SOURCES OF MATERIAL IDENTIFICATION

This chapter presents different sources of information that is needed in performing technical research. Material identification does not end with the assignment of the NSN. Some means of identifying other particular needs by the stock number must be provided to the customers. This includes the means of determining the correct quantities of these items to carry in stock. Identification of needs maybe determined by using the lists described in the following paragraphs.

FEDERAL LOGISTICS (FED LOG)

The FED LOG on Compact Disc Read-Only Memory (CD-ROM) (fig.7-21) is the access to DOD logistics data. The FED LOG includes the basic management data necessary for preparing requisitions and it includes an integrated historical record of deleted and superseded NIINs with appropriate codes to indicate disposition action.

PART NUMBER

The part number, also called reference number, is an identification number assigned to an item by the manufacture. It is made up of letters, numbers, or combinations of both. When used with the Commercial And Government Entity (CAGE) code, it identifies the item. It is used with other technical data (for example, model, series, and end-use application) to requisition an item when an NSN is not assigned. Part number to NSN cross-reference is provided in FED-LOG.

Federal Logistics Data on Compact Disc (FED LOG)													
Management Data Response for NSN 2810-00-118-8356													
User's ID:											JUN 97		
Item Name: TUBE *											1 of 9 tagged		
Today's Date: 01 JUN 97											NAVY		
S/A	SOS	AAC	QUP	UI	Unit Price	SLC	CIIC	RC	MGMT	CTL	PMI	ADP	DML
PC	Phrase	Statment					UI	Conv	Factor			OOU	JTC
DF	FPZ	Y	5	EA	6.41	0	7				3		J
DF	FPZ	Y	5	EA	6.41	0	7	N	MDIPD	V	3		J
	N DISPOSAL												

HELP	NEW SEARCH	SELECT VIEWS		PREV VIEW	NEXT VIEW	PRINT	PREV NIIN	NEXT NIIN		EXIT SYSTEM
------	------------	--------------	--	-----------	-----------	-------	-----------	-----------	--	-------------

ABEF0721

Figure 7-21.—Example of FED LOG query.

COMMERCIAL AND GOVERNMENT ENTITY CODE

The Commercial And Government Entity (CAGE) (fig. 7-22) Code is a five-digit, numeric identification code assigned to manufacturers which have previously or are currently producing items used by the Federal Government. The CAGE is used in conjunction with part number, item number, symbol, or trade name assigned by the manufacturer to his product. The CAGE catalog handbook is published the Defense Logistics Information Service (DLIS) on the FED LOG CD-ROM.

MANAGEMENT LIST-CONSOLIDATED (ML-C)

The Management-List Consolidated (ML-C) is a consolidated, cumulative listing of National Stock Numbers for all branches of the armed services. Each NSN is listed one time only. The integrated material manager and service or agency is listed separately. The ML-C is a tool used for determining management data applicable to items used or managed by other military activities.

MASTER CROSS-REFERENCE LIST (MCRL)

The Master Cross-Reference List (MCRL) (fig. 7-23) Part I, provides a cross-reference from a reference number (manufacturer's part number, drawing number, design control number, etc.) to its assigned National Stock Numbers (NSN). The MCRL, Part II, provides a cross-reference from an NSN to a reference number. The MCRL is published on the FED LOG CD-ROM.

MASTER REPAIRABLE ITEM LIST (MRIL)

The Master Repairable Item List (MRIL) (fig. 7-24 and 7-25) is a catalog of selected Navy-managed items which, when are unserviceable and not locally repairable, are required to be turned in to a Designated Overhaul Point (DOP) for repair and return to system stock. The MRIL is part of the FED LOG that is distributed in compact disc format. The MRIL is published on the FED LOG CD-ROM and is made up of two parts as shown in figures 7-24 and 7-25.

Federal Logistics Data on Compact Disc (FED LOG)									
Supplier Data Response for NSN 2810-00-118-8356									
User s ID:			JUN 97						
Item Name: TUBE *			1 of 9 tagged						
Today s Date: 01 JUN 97			NAVY						
<hr/>									
Company Name: PRATT AND WHITNEY CANADA INC									
Address: 1000 MARIE-VICTORIN BLVD									
LONGUEUIL QUE CAN J4G 1A1									
Zip Code:									
Telephone: 514-662-8333									
CAGE Code: 00198									
Status: A									
Type: U.S./CANADIAN MANUFACTURER									
<hr/>									
Use PAGE UP/DOWN to view additional records for the current NIIN.									
HELP	NEW SEARCH	SELECT VIEWS	PREV VIEW	NEXT VIEW	PRINT	PREV NIIN	NEXT NIIN	EXIT SYSTEM	

ABEF0722

Figure 7-22.—Example of CAGE from FED LOG.

Federal Logistics Data on Compact Disc (FED LOG)
Reference Number Data Response for NSN 2810-00-118-8356

User s ID:
Item Name: TUBE *
Today s Date: 01 JUN 97

JUN 97
1 of 9 tagged
NAVY

Reference Number	CAGE	ISC	RNVC	RNCC	SADC	DA
AS12345	12776	6	2	3		
12345	00198	6	2	3		
12345	77445	6	9	5		

HELP	NEW SEARCH	SELECT VIEWS	PREV VIEW	NEXT VIEW	PRINT	PREV NIIN	NEXT NIIN	EXIT SYSTEM
------	------------	--------------	-----------	-----------	-------	-----------	-----------	-------------

ABE10723

Figure 7-23.—MCRL from FED LOG.

Federal Logistics Data on Compact Disc (FED LOG)
MRIL Response for NSN/NICN 6610-00-000-0089

User s ID:
Item Name: CIRCUIT CARD ASSEMBLY
Today s Date: 01 JUN 97

JUN 97
1 of 2 tagged
NAVY

LSI SRC	COG	MCC	MODEL NUMBER	SMIC	SSC	RMC	RC	CIIC	MPD	RIP
	7R	H		CS		G	D	U	13	

SHIPPING DATA

NOTES	SHIPPING CODE
MAILABLE CAND	C20481
CTNR002609562	999991

HELP	NEW SEARCH	SELECT VIEWS	SHIP DATA	PREV VIEW	NEXT VIEW	PRINT	PREV NIIN	NEXT NIIN	EXIT SYSTEM
------	------------	--------------	-----------	-----------	-----------	-------	-----------	-----------	-------------

ABE10724

Figure 7-24.—MRIL Part I from FED LOG.

Federal Logistics Data on Compact Disc (FED LOG)
MRIL Response for Shipping Code C20481

User s ID:
Today s Date: 01 JUN 97

JUN 97
1 of 2 tagged
NAVY

SHIPPING INSTRUCTIONS

BENDIX CORP FLGT SYS DIV.
3625 INDUSTRY AVENUE
LAKEWOOD, CA. 90712
ATTENTION OF
DCASMA SANTA ANA
SPECIAL MARKINGS
FOR OVHL AND/OR REPIAR ON CONTRACT
N00383-90-D-2121 DTD 20 DEC 94
MAIL COPIES OF DD FORM 1348-1 TO
NAVY AVIATION SUPPLY OFFICE (CODE MAS-2)
700 ROBBINS AVE
PHILADELPHIA PA 19111
MILSTRIP SPECIAL ENTRIES

Use PAGE UP/DOWN to view additional records for the current NIIN

HELP	NEW SEARCH	SELECT VIEWS		PREV VIEW	NEXT VIEW	PRINT	PREV NIIN	NEXT NIIN		EXIT SYSTEM
------	---------------	-----------------	--	--------------	--------------	-------	--------------	--------------	--	----------------

ABEF0725

Figure 7-25.—MRIL Part II from FED LOG.

AFLOAT SHOPPING GUIDE

The *Afloat Shopping Guide* (ASG) (fig. 7-26) is designed to assist the fleet personnel in identifying the NSNs for items that are frequently requested by ships. It includes a detailed description of each item, and (when applicable) the stock number for substitute items. The ASG is distributed in CD-ROM format and in printed form.

GENERAL SERVICES ADMINISTRATION FEDERAL SUPPLY CATALOG

The *General Services Administration* (GSA) *Federal Supply Catalog* lists approximately 20,000 line items that are stocked in GSA supply distribution facilities. The items listed in this catalog are assigned cognizance 9Q. The GSA supply catalog series serves as the major merchandising instrument of the Federal Supply Service (FSS) Stock Program. Since they are prepared for civilian agencies, the FED LOG must be

referred to for supply management data. The GSA supply catalog series consists of the following:

The *GSA Supply Catalog Guide* contains consolidated alphabetical and NSN indexes to all stock items. These are items listed in the four commodity catalogs and other items available through the FSS program. It provides detailed information concerning the program and requisitioning procedures.

The *GSA Supply Catalog (Tools)* contains listings of common and special use tools. It includes alphabetical and numerical indexes and a price list.

The *GSA Supply Catalog (Office Products)* lists a wide variety of items for office use, including paper supplies, standard and optional forms, and many items of equipment. It includes alphabetical and numerical indexes and a price list.

The *GSA Supply Catalog (Industrial Products)* contains descriptive listings of a broad range of items, such as hardware, paints, adhesives, and cleaning

GROUP 48 VALVES CLASS 4820 VALVES, NONPOWERED

BIBB TYPE

BOOT DUST AND MOISTURE SEAL

Silicone Rubber Body, thru-hole style. Compression type mtg. 1.469 in. O/A H. .080 in. thk., 2.000 in. body OD, 2.875 in. base OD, 1.875 in. base ID, and .875 opening ID. Used on Valves, Pressure Regulating. Leslie Co Navy Sales Ref No. 37740.

00-615-6762

Threaded male pipe inlet. Brass body. Angle type with level handle. Spec MIL-C-1203, 150 PSI steam service.



125 PSI

00-826-2190	1/8-27NPT	MS35785-1
00-272-3340	1/8-27NPT	
00-197-4984	1/4-18NPT	MS35785-2
00-554-8391*	1/2-14NPT	MS35785-4

*Disc or stem flow control device.

COCK, DRAIN

AUTOMOTIVE TYPE

Threaded male pipe inlet. Brass body. For use in fluid pipping systems up to 150 PSI pressure.

Straight Internal Seat

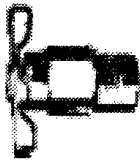

00-272-3332	1/8-27NPTF	MS35787-1
00-272-3333	1/4-18NPT	
00-272-3335	1/2-14NPT	MS35787-4

Threaded male pipe inlet. Brass body, T handle w/hose bib that accommodates 3/8 in. ID hose. Has 150 PSI liquid/gas rating.



00-845-1096	1/4-18NPTF	MS35783-2
-------------	------------	-----------

00-684-0880	1/8-27NPTF	MS35782-1
00-720-4488	1/4-18NPTF	MS35782-2
00-174-0339	3/8-18NPTF	MS35782-3

Straight External Seat



PET TYPE

Threaded male pipe inlet. Brass body, F use in liquid or gas systems up to pressure as indicated below. Spec MIL-C-1203.



COCK, PLUG

FEMALE ENDS

Threaded female pipe inlet. Brass body, 360 deg, plug turn. Furnished with square head wrench. For use in fluid piping systems. Spec MIL-C-1203.



00-274-3565	3/4-14NPT
-------------	-----------

FEMALE to MALE

Threaded female and male pipe ends. Brass body. For use with fluid or gas to 125 PSI pressure.

00-752-9040	1/8-27NPTF	MS35782-4	50 PSI
00-849-1220	1/4-18NPTF	MS35782-5	

Cross Extrernal Seat

00-276-9041	3/8-18NPT	MS35782-6
-------------	-----------	-----------

00-555-9761	1/8-27NPTF	MS35784-1
00-287-4268	1/4-18NPTF	MS35784-2
00-272-3346	3/8-18NPTF	MS35784-3
00-272-3347	1/2-14NPTF	MS35784-4

CONTINUED ON FOLLOWING PAGE

ABEF0726

Figure 7-26.—Page from *Afloat Shopping Guide*.

equipment and supplies. It includes alphabetical and numerical indexes and a price list.

The *GSA Supply Catalog (Furniture)* provides a single source of information for all furniture items stocked by the FSS.

NAVY STOCK LIST OF PUBLICATIONS, FORMS, AND DIRECTIVES

The *Navy Stock List of Publications, Forms, and Directives*, NAVSUP P-2002, contains requisitioning procedures and sources of supply to assist in the determination of how and where material may be obtained.

HAZARDOUS MATERIAL INFORMATION SYSTEM

The DOD Hazardous Material Information System (HMIS) provides information concerning the use, procurement, receipt, storage, and expenditure of hazardous material. The NAVSUPSYSCOM maintains and distributes the HMIS hazardous item list. This list includes information concerning hazardous ingredients, use of hazardous material, protective clothing, and emergency treatment.

ILLUSTRATED PARTS BREAKDOWN

An illustrated Parts Breakdown (IPB) is prepared by the manufacturer for each model aircraft, engine, accessory, electronic equipment, support equipment, or other equipment considered advisable by NAVAIR. The IPB is printed and issued by the authority of NAVAIR. It is used as reference for identifying and ordering replacement items. Each item of equipment is listed in assembly breakdown order, with the illustration placed as close as possible to its appropriate listing. Some IPBs have a different format from others.

The TABLE OF CONTENTS shows the breakdown of publication into sections. It also furnishes an alphabetical listing of the various assemblies and lists the page, work package, or figures where they are illustrated.

The GROUP ASSEMBLY PARTS LIST is the main text of the publication. It consists of series of illustrations and parts list in which parts of the aircraft or equipment are shown in assembly breakdown order. The items in the illustration pages are identified by index numbers. These index numbers match the numbers listed in the parts list of the assembly breakdown. The parts list is arranged in numerical

sequence by index number to make it easier to use. The information in the parts list include index number, part number, description, units per assembly, Usable On code, and the Source, Maintenance, and Recoverability (SM&R) code. Each major assembly in the parts list is followed immediately by its component parts or subassemblies. Component parts listed in the description column may be prefixed with a dot or indented to show their relationship. You should use this information to identify and obtain the required material in accordance with the SM&R code. The numerical index of the IPB lists all parts in reference/part number sequence. Each reference/part number is cross-referenced to the figure and index number or the work package where the item is listed in the text.

SOURCE, MAINTENANCE, AND RECOVERABILITY CODES

The SM&R code consists of two-position source code, two single-position maintenance codes, single-position recoverability code, and if applicable, a single-position service option code. Table 7-7 breaks down the SM&R code by position and defines the source, maintenance level, and reparability level of the component.

Source Code: The source code is a two-character code that occupies the first two positions of the SM&R code format. This code shows the manner of getting the material needed for maintenance, repair, or rework of items.

Maintenance Code: The maintenance codes are indicated in the third and fourth positions of the SM&R code. Levels of maintenance authorized to replace and repair an assembly or part are given. The code shown in the third position provides the lowest level of maintenance authorized to remove or replace the assembly or part. The fourth position indicates if the item is to be repaired and identifies the lowest maintenance level authorized to perform the repair.

Recoverability Code: The Recoverability Code is indicated in the fifth position, this code defines the approved disposition of unserviceable items.

CASUALTY REPORTING (CASREP)

The casualty report (CASREP) was designed to support the Chief of Naval Operations (CNO) and fleet commanders in the management of assigned forces. The effective use and support of Navy forces requires an up-to-date, accurate operational status for each unit. An important part of operational status is casualty

Table 7-7.—SM&R Code Format

TABLE 2. NAVY (AVIATION) APPLICATION OF JOINT SERVICE UNIFORM SM&R CODES UNDER NAVAIRINST 4423.11

SOURCE		MAINTENANCE		RECOVERABILITY/ PROGRESSIVE REPAIR		OPTIONAL SUPPLEMENTAL CODES					
		USE	REPAIR								
1ST POSITION	2ND POSITION	3RD POSITION	4TH POSITION	5TH POSITION		6TH POSITION					
P	PROCEDURE	A	REPLENISH	O	ORG	Z	NO REPAIR (CONSUMABLE)	Z	LEVEL INDICATED IN 3RD POSITION (CONSUMABLE)	1	THREE-DEGREE GAS TURBINE ENGINE REPAIR PROGRAM ITEM WITH FIRST DEGREE IMA LEVEL (1) HAVING THE MOST CAPABILITY AND THIRD-DEGREE IMA (3) HAVING THE LEAST
		B	INSURANCE			O	ORG	O	ORG (FLR)		
		C	CURE-DATED			F	IMA AFLOAT	F	IMA AFLOAT (FLR)		
		D	INITIAL (EXCLUDING SE)	H	IMA ASHORE	H	IMA ASHORE (FLR)	E	END TO END TEST REQUIRED BY IMA PRIOR TO BCM ACTION		
		E	END ITEM SE STOCKED FOR INITIAL ISSUE	G	IMA AFLOAT OR ASHORE	G	IMA AFLOAT OR ASHORE (FLR)	N	"XB" ITEM TO BE PROCURED LOCALLY		
		F	SE NOT STOCKED	L	SPECIALIZED IMA	L	SPECIALIZED IMA	L	SPECIALIZED IMA (FLR) (CONNOTES PRIME IMA CONCEPT- SEE APPENDIX D ENCL (2) NOTE IN INSTRUCTION)	P	PROGRESSIVE MAINTENANCE
		G	LIFE OR TYPE	D	DEPOT	D	DEPOT	D	DEPOT (DLR) (ORGANIC OR COMMERCIAL)	T	"PD" TRAINING DEVICE ITEM
K	REPAIR KIT COMPONENT	F	FIELD (ORG IMA)	D	DEPOT	D	DEPOT	D	DEPOT (DLR) (ORGANIC OR COMMERCIAL)	J	ALL INTER-SERVICE DLR ITEMS WHICH NAVY AS SICA CONSIDERS FLR-IF ITEM IS UNDER THREE-DEGREE GAS TURBINE ENGINE REPAIR PROGRAM, APPLIES TO FIRST- DEGREE IMA LEVEL ONLY
D	DEPOT										
B	BOTH										
M	MANUFACTURE	O	ORG	D	DEPOT	D	DEPOT	D	DEPOT (DLR) (ORGANIC OR COMMERCIAL)	J	ALL INTER-SERVICE DLR ITEMS WHICH NAVY AS SICA CONSIDERS FLR-IF ITEM IS UNDER THREE-DEGREE GAS TURBINE ENGINE REPAIR PROGRAM, APPLIES TO FIRST- DEGREE IMA LEVEL ONLY
F	IMA AFLOAT										
H	IMA ASHORE										
A	ASSEMBLE	G	IMA AFLOAT OR ASHORE	D	DEPOT	D	DEPOT	D	DEPOT (DLR) (ORGANIC OR COMMERCIAL)	J	ALL INTER-SERVICE DLR ITEMS WHICH NAVY AS SICA CONSIDERS FLR-IF ITEM IS UNDER THREE-DEGREE GAS TURBINE ENGINE REPAIR PROGRAM, APPLIES TO FIRST- DEGREE IMA LEVEL ONLY
		D	DEPOT								
X	MISC.	A	REQUEST NHA	Z	NOT AUTHORIZED AT ANY LEVEL- USED ONLY WHEN REQUIRED FOR REFERENCE PURPOSES	B	NOT AUTHORIZED (RECONDITION AT USER LEVEL)	A	SPECIAL HANDLING FOR DISPOSAL (CONSUMABLE)	8	SAME AS "J" EXCEPT APPLICABLE ONLY TO SECOND DEGREE IMA LEVEL
		B	OBTAIN FROM SALVAGE OR ONE TIME BUY								
		C	DIAGRAMS SCHEMATICS INSTALLATION DRAWINGS								
9				Z	NOT AUTHORIZED AT ANY LEVEL- USED ONLY WHEN REQUIRED FOR REFERENCE PURPOSES	B	NOT AUTHORIZED (RECONDITION AT USER LEVEL)	A	SPECIAL HANDLING FOR DISPOSAL (CONSUMABLE)	9	SAME AS "J" EXCEPT APPLICABLE ONLY TO THIRD-DEGREE IMA LEVEL

ABE0707

information. The CASREP system contains four types of reports: Initial, Update, Correct, and Cancel. These reports are described in general in the following paragraphs.

Initial Casualty Report (INITIAL)

An initial casrep identifies the status of the casualty and any parts or assistance needed. Operational and staff authorities use this information to set priorities for the use of resources.

Update Casualty Report (UPDATE)

An update casrep is used to submit changes to previously submitted information.

Correction Casualty Report (CORRECT)

A correct casrep is submitted when equipment that has been the subject of casualty reporting is repaired and is back in operational condition.

Cancellation Casualty Report (CANCEL)

A cancel casrep is submitted when equipment that has been the subject of casualty reporting is scheduled to be repaired during an overhaul or some other availability. Outstanding casualties that will not be repaired during such availability will not be canceled and will be subject to normal follow-up casualty reporting procedures as specified.

REVIEW QUESTIONS

- Q11. National Stock Numbers are made up of how many digits?
- Q12. What occupies the first part of a National Stock Number?
- Q13. What does the Cognizant Symbol identify?
- Q14. The Afloat Shopping Guide is designed for what purpose?
- Q15. List the different types of casualty reports.

ADMINISTRATION

LEARNING OBJECTIVE: Describe the use and maintenance of various logs and reports used to record details of catapult and arresting gear operations and maintenance

Record keeping in relation to launch and recovery equipment is as important as the operation of the machinery or maintenance procedures. Because of the many 3-M maintenance requirements that must be adhered to and periodic reports that must be made, the important of accurate logs, reports, and records should be emphasized.

CATAPULT WORK CENTER MAINTENANCE LOG

The work center maintenance log (fig. 7-27) is the most important record kept on the catapult systems. Each catapult workcenter supervisor shall maintain a separate maintenance log for each catapult. Sufficient pages in the front of the log should be reserved for entering data of a historical or permanent nature, which will provide a read reference when required. Daily entries should be made listing all maintenance performed during a 24-hour period. This will provide a continuous record of maintenance actions performed

1. Data which may be required periodically or could affect equipment over long periods of time should be entered in the front section of the maintenance log and transferred to new logs as necessary. Listed below are some examples:
 - a. At shot number 75,982 the launch valve and its associated CSV were replaced by overhauled launch valve SN 88006 and CSV, SN EMP-S-124. Valve characteristics at certification are as follows:
 - (1) Cold launch valve cycle times:

CSV	CLOCK TIMES (SEC)		FULL OPEN TIME (SEC)	CLOSE
	1	2		
050	0.81	9.22	20.11	
100	0.56	3.78	7.87	
150	0.42	2.24	4.54	0.55
200	0.34	1.55	3.08	
250	0.28	1.16	2.31	
300	0.23	0.92	1.80	
300	0.23	0.92	1.80	
250	0.27	1.16	2.30	
200	0.33	1.54	3.10	0.55
150	0.42	2.23	4.52	
100	0.55	3.78	7.87	
050	0.80	9.24	20.13	

- (2) Cold low-pressure actuations, CSV 300:

TENSIONER REQ PRESS (PSI)	OPENING			OPENING TIME
	OPENING PRESSURE	FINAL OPENING PRESSURE		
95	25	95		01:12
95	25	95		01:05
Average 95	25	95		01:08
CLOSING				
95	20	95		01:19
95	20	95		01:17
Average 95	20	95		01:18

ABE10727

Figure 7-27.—Catapult maintenance log entries.

MAINTENANCE LOG

1. Data which may be required periodically or could affect equipment over long periods of time should be entered in the front section of the maintenance log and transferred to new logs as necessary. Listed below are some samples for arresting gear engine number four:

- a. Length of retract valve control cable: 275 feet 10 inches.
- b. Length of barricade retract valve control cable: 248 feet 11 inches.
- c. Include any additional items which may aid in work package development for overhauls, ship's restricted availability, etc., such as excessive slipper wear, which could indicate a possible out-of-alignment situation.
- d. The remainder of the maintenance log should consist of daily entries containing all maintenance performed in a 24-hour period. Include with the daily entries the P/N, manufacturer and any other component identification available for any replacement part.

ABEF0729

Figure 7-29.—Arresting gear maintenance log entries.

RECOVERY LOG (FOR USE IN PRI-FLY)														
NAVAIR FORM 13810/4 (8-75)														
FROM										SHIP IDENTIFICATION NO.			DATE	
U.S.S. KITTY HAWK										CV-63			01/10/96	
TO (ORIGINAL ONLY) (MONTHLY)														
COMMANDING OFFICER, NAVAL AIR WARFARE CENTER (CODE 4.8.10.4) LAKEHURST, NEW JERSEY 08733-5090														
RECOVERY NO.	PENDANT NO.	TIME	TYPE	SIDENO.	WEIGHT	APP SPEED	WIND OVER DECK	(1) DISTANCE OFF CENTER	(2) LANDING TYPE	(3) ENGINE WEIGHT SETTING	(3) RAM TRAVEL	(3)(4) F.L.S.	(4) B.A.	(5) REMARKS
300608	P3	10:00	F1A18	300	36.0		22	0	RI	36.0	180	18.7	.50	
300609	P3	10:01	F1A18	310	36.0		23	2P	RI	36.0	181	18.7	.50	
300610	P2	10:02	F-14	203	54.0		25	0	RI	54.0	182	19.7	.50	
300611	P4	10:03	F-14	111	54.0		27	3S	RI	54.0	180	19.7	.50	
300612	P3	10:05	S-3	706	41.0		27	0	RI	41.0	180	14.5	.50	
300613	P1	10:06	EA-6B	621	46.0		30	0	RI	46.0	180	18.8	.50	
300614	P3	10:07	F-14	103	54.0		29	0	RI	54.0	178	19.7	.50	
300615	P3	11:17	F1A18	353	36.0		25	0	RI	36.0	180	18.7	.50	#3 CDP CHANGE BW

SAMPLE ONLY

(1) IF ON CENTER, WRITE "0"; IF OFF CENTER, INDICATE NUMBER OF FEET AND WHETHER TO PORT OR STARBOARD, I.E., "12S" (12 FEET TO STARBOARD)
 (2) WRITE "FF" (FREE FLIGHT) OR "RI" (ROLL-IN)
 (3) OBTAIN FROM ENGINE COMPARTMENT
 (4) FRESNEL LENS SETTING/BASIC ANGLE: MAKE ALL ENTRIES IN DECIMAL FOR
 (5) ENTER ALL UNUSUAL EVENTS, INCLUDING: 2-WIRE ENGAGEMENT, CABLE DAMAGE TO AIRCRAFT, PENDANT CHANGE AND REASON

ABEF0730

Figure 7-30.—Recovery Log sheet (NAVAIR Form 13810/4).

WIRE ROPE HISTORY REPORT

The wire rope history chart (fig. 7-31) provides a uniform system for recording arresting gear wire rope data. Engine operators shall maintain this for each specific engine, with the last recovery number being obtained from pri-fly. A new sheet shall be used at the beginning of each month.

FLIGHT DECK OPERATIONS (NAVAIR FORM 13810/1 AND 138/1A)

The flight operation report (fig. 7-32) and (fig. -33) is a two part form and is compiled from information contained in the catapult shot logs and the arresting gear recovery logs.

ALRE AUTO SHOT RECOVERY LOG PROGRAM

The Auto shot and recovery log program provides a computerized program for the collection and dissemination of launch and recovery log data. The automated program has been developed to record the Shot Log, Recovery Log, and the Wire Rope History

Report on computer disc. These discs would then be sent to NAWC Lakehurst vice the paper forms.

REVIEW QUESTIONS

Q16. *The work center maintenance logs are retained for what minimum period of time?*

SUMMARY

In this chapter, you learned that the Planned Maintenance System is a means for accomplishing preventive maintenance aboard ship. You also learned that PMS procedures for a specific piece of equipment are based on good engineering practices, practical experience, and technical standards. You studied the role the Maintenance Data System has in planning workloads and providing a database for evaluating and improving equipment installed in the fleet. The supply information in this chapter is not intended to make you an expert in supply matters. Rather, this section was developed to give you a basic understanding and provide you with some of the information needed for ordering supplies. You also studied the maintenance logs and reports for recording the details of catapult and arresting gear operations and maintenance.

RECOVERY WIRE ROPE HISTORY
NAVAIR FORM 13810/5 (REV. 8-75)

FROM:	SHIP IDENT. NO.	ENGINE IDENT. NO.	PENDANT NO.	MK 7 MOD	MONTH & YEAR	NOTE: ALL DATA (EXCEPT PENDANT REPLACED) APPLIES TO PURCHASE CABLE
USS KITTY HAWK (CV-63)	03363	357	ONE	3	FEB 95	

TO: (ORIGINAL) (MONTHLY)
COMMANDING OFFICER, NAVAL AVIATION WARFARE CENTER A/C DIVISION (CODE 4.8.10.4) LAKEHURST, N.J. 08733

ENGINE ENGAGEMENT NUMBER	DATE	LAST RECOVERY NUMBER	NO. OF HITS ON PURCHASE CABLE	"Q" FACTOR		BROKEN WIRES		TERMINAL REPLACEMENT REASON (4)	PURCHASE CABLE REPLACEMENT REASON (3) (5)	NEW CABLE DATA			PENDANT REPLACEMENT AND REASON	REMARKS
				VALUE (2)	LOC (3)	QUAN	LOC (2) (3)			REEL NUMBER	CONTRACT NUMBER	MANUFACTURER		
2566	07 FEB	300331	486	11 7/16	8P									M-2R PCI
				11 7/16	20P									
				11 7/16	8S									
				11 1/4	20S									
2594	09 FEB	300935	511										"BW"	76 HITS
2601	09 FEB	300943	519										"MAX H"	96 HITS
2619	11 FEB	301576	537										"MAX H"	96 HITS

LEGEND: (1) OBTAIN FROM PRI-FLY. (2) DISTANCE (FT) FROM DECK TERMINAL. (3) SPECIFY WHETHER PORT OR STBD ACTIONS. (4) FOR TERMINAL REPLACED, INDICATE DUE TO "S" (STRETCH), "R" (RECESSION OF WIRES), OR "Z" (ZINC). (5) REASON FOR REPLACEMENT OF "MAX H" (MAXHITS). "Q" (MIN. Q FACTOR) "BW" (BROKEN WIRES), "K" (KINK), "COR" (CORROSION). AMPLIFY UNDER REMARKS IF REQUIRED.

ABEf0731

Figure 7-31.—Recovery Wire Rope History chart (NAVAIR Form 13810/5).

FLIGHT DECK OPERATIONS (PART I - LAUNCHING)
 NAVAIR FORM 13810/01 (Rev. 8-79) S/N 0102-LF-613-8101

FROM COMMANDING OFFICER USS KITTY HAWK (CV 63) FPO AP 96634-2770 CALENDAR YEAR 1995	TO COMMANDING OFFICER NAVAL AIR WARFARE CENTER (CODE 48J400) LAKEHURST, N.J. 08733-5092 QUARTER JAN/FEB/MAR
--	--

AIRCRAFT SERIES AND MODEL NO.	DAY OR NIGHT	BOW		WAIST		TOUCH AND GO OR FREE-DECK AND HELO TAKE-OFFS
		NO. 1	NO. 2	NO. 3	NO. 4	
A-6	D	39	66	0	0	
	N	24	21	0	0	
C-2	D	22	2	0	0	
	N	2	0	0	0	
EA-6B	D	52	62	0	0	
	N	38	29	0	0	
E-2C	D	67	2	0	0	
	N	32	0	0	0	
F-14	D	112	6	0	0	
	N	56	0	0	0	
F/A-18	D	162	33	0	0	
	N	101	18	0	0	
S-3	D	144	11	0	0	
	N	70	6	0	0	
	D					
	N					
	D					
	N					
SUB-TOTAL		921	655	0	0	
NO LOADS		76	14	14	14	
DEAD LOADS		0	0	0	0	
TOTAL CATAPULT LAUNCHES THIS REPORT		1576	327, 375			
TOTAL CATAPULT LAUNCHES TO DATE						
TOTAL HELO TAKE-OFFS THIS REPORT						
TOTAL HELO TAKE-OFFS TO DATE						N/A

LAUNCHING INCIDENTS

List date and summary of all launching incidents, include message DTG, if applicable; note circumstances of runaway shots or launching incident due to material failure or malfunction of equipment including launching accessories; note any significant downtime and reason. Include other pertinent remarks. (continue on reverse if necessary)

ABE10732

Figure 7-32.—Flight Deck Operations (Part I) (NAVAIR Form 13810/1).

FLIGHT DECK OPERATIONS (PART II - LANDING)
 NAVAIR FORM 13810/1A (REV.8-79) S/N 0102-LF-613-8106

REPORT SYMBOL NAVAIR 13810-1

FROM
 COMMANDING OFFICER
 USS KITTY HAWK (CV-63)
 FPO AP 96634-2770

TO
 COMMANDING OFFICER
 NAVAL AIR WARFARE CENTER (CODE 4.8.10)
 LAKEHURST, NJ 08733-5092

CALENDAR YEAR
 1997

QUARTER
 JAN/FEB/MAR

AIRCRAFT SERIES AND MODEL NO.	DAY OR NIGHT	ARRESTED LANDINGS	BOLTER (CAUSE)		TOUCH AND GO OR HELO LANDING	PENDANT NO.	LANDING PER PENDANT POSITION	NO. HITS EACH PENDANT CHANGED
			MW	MLA				
			0	0	0	P1	152	94
EA-6B	D	120	0	0	0	P2	998	98, 78, 88, 90, 63, 93, 80, 90
	N	40	0	0	0			
F-14A	D	970	0	0	0	P3	2114	93, 98, 95, 97, 99, 65, 100, 95, 98, 100, 99, 82, 100
	N	124	0	0	0			
F/A-18	D	1120	0	0	0	P4	152	96, 83, 90
	N	190	0	0	0			
E-2C	D	115	0	0	0	P5	0	
	N	36	0	0	0			
US-3A	D	80						
	N	0						
						TOTAL ARRESTED LANDINGS THIS REPORT 3895		
S-3B	D	860				TOTAL ARRESTED LANDINGS TO DATE 283259		
	N	240				TOTAL HELO LANDINGS THIS REPORT		
						TOTAL HELO LANDINGS TO DATE		

LANDING INCIDENTS: List date and summary of all landing incidents, include message DTG if applicable, note circumstances of all barricade engagements, failure of landing gear arresting hooks, cable, etc., or arresting gear malfunction and significant down-time. Give cause of purchase cable replacement and number of arrestments. Include other pertinent remarks. (Continue on reverse if necessary.)

1. Replaced purchase cables on P3 after maximum traps (reduced by heavies) of 1500.
2. Replaced purchase cables on P4 after 1467 traps due to exceeding "Q" factor limits.

SIGNATURE (Commanding Officer)

DATE

COPY TO TYPE COMMANDER

ABE0733

Figure 7-33.—Flight Deck Operations (Part II) (NAVAIR Form 13810/1A).

APPENDIX I

GLOSSARY

ABE—Aviation Boatswain's Mate (Launching and Recovery Equipment).

ABRASION—Wearing away of a surface by friction, either by motion while in contact with another part or by mechanical cleaning or resurfacing with abrasive cloth or compound.

ac—Alternating current.

ACHO—Aircraft Handling Officer.

ACNO—Assistant Chief of Naval Operations.

ACTIVATE—To put into action mechanically.

ACTUATE—To put into action electrically.

ADP—Automated Data Processing.

AEL—Allowance Equipage List.

AIMD—Aircraft Intermediate Maintenance Department.

ALINEMENT—Parts in correct related positions as specified on manufacturing drawings.

ALRE—Aircraft Launch and Recovery Equipment.

ALREMP—Aircraft Launch and Recovery Equipment Maintenance Program.

AMBIENT TEMPERATURE—The surrounding temperature.

APL—Allowance Parts List.

ASG—Afloat Shopping Guide.

ATMOSPHERIC PRESSURE—The normal pressure of the air at sea level (14.7 psi).

AWM—Awaiting Maintenance.

AWP—Awaiting Parts.

AWR—Automated Work Request.

BACK OUT—To remove a screw or other threaded part from its fully torqued or set position.

BINDING—The stopping or the slowing down of motion between two surfaces because of foreign matter, poor alinement of ports, unequal expansion, or unequal wear between surfaces.

BRAZE—To join two metals by intense heat and the application of a hard solder containing brass.

BRINELLING—A displacement or flow of metal rather than a loss of metal due to wear.

BULB SIDE—The side of the launching-engine cylinders that mates directly with the cylinder covers and is opposite the sealing-strip side.

BUR—A sharp projection of metal from an edge, usually the result of drilling, boring, counter-sinking, and so forth, but may also be caused by excessive wear of one or both surfaces adjacent to the burred edge.

CAFSU—Carrier and field service unit.

CALIBRATION—To check, fix, or correct the graduation of a measuring instrument.

CALIPERS—An instrument composed of two curved hinged legs, used for measuring internal and external dimensions.

CASREP—Casualty Report.

CAUTION—An emphatic notice requiring correct operating or maintenance procedures to prevent damage to equipment.

CDI—Collateral Duty Inspector.

CDP—Cross Deck Pendant.

CDQAI—Collateral Duty Quality Assurance Inspector.

CHAMFER—To bevel to a sharp external edge.

CHARGE—To pressurize a hydraulic or pneumatic system with fluid or air.

CHATTER—Vibration caused by uneven motion of a machine, possibly resulting in damage to parts.

CIRCUMFERENCE—A line around a closed figure of area.

CNO—Chief of Naval Operations.

COGNIZANT—Pertaining to the responsible upper authority who can make a final decision on a specific matter.

COH—Complex Overhaul.

COMCARGRU—Commander Carrier Group.

COME-ALONG—Ratchet hoist.

COMFAIRMED—Commander Fleet Air, Mediterranean.

COMFAIRWESTPAC—Commander Fleet Air, Western Pacific.

COMNAVAIRLANT—Commander Naval Air Force, U.S. Atlantic Fleet.

COMNAVAIRPAC—Commander Naval Air Force, U.S. Pacific Fleet.

COMNAVAIRSYSCOM—Commander Naval Air Systems Command.

COMNAVSEASYSYSCOM—Commander Naval Sea Systems Command.

COMNAVSURFLANT—Commander Naval Surface Force, U.S. Atlantic Fleet.

COMNAVSURFPAC—Commander Naval Surface Force, U.S. Pacific Fleet.

COMPONENT—A part of an assembly or sub-assembly.

CONCENTRICITY—Having a common axis or center. Usually refers to the closeness of tolerances between the common center of two or more circles (bore and outside diameter, bore and bolt circle diameters, and so forth).

CONDENSATE—The liquid that forms when a gas or vapor, such as steam, is cooled.

CONTINUITY—The completeness of an electrical circuit.

CORROSION—Deterioration of a metal surface, usually caused by moist, salty air.

COSAL—Coordinated Shipboard Allowance List.

CROV—Constant Run Out Valve.

CSMP—Current Ship's Maintenance Project.

CSV—Capacity Selector Valve.

CV—Multi-purpose aircraft carrier.

CVN—Nuclear-powered multi-purpose aircraft carrier.

DLA—Defense Logistics Agency.

D-LEVEL—Depot level.

DEAD LOAD—A wheeled vehicle used instead of an aircraft during catapult testing.

DEENERGIZE—To remove from operation electrically.

DEFORMATION—A change in the shape or dimensions of a body, due to overstressing or repeated usage.

DEPRESSURIZE—To remove air or hydraulic fluid from a system.

DIAMETER—The width or thickness of a part.

DIAMETRICAL CLEARANCE—The difference between the inside diameter (ID) of one part and the outside diameter (OD) of another part when both parts have the same axis.

DOD—Department of Defense.

DON—Department of the Navy.

DSCC—Defense Supply Center Columbus.

DSCP—Defense Supply Center Philadelphia.

DYNAMOMETER—A device used to measure force.

EI—Engineering Investigation.

EIC—Equipment Identification Code.

ELONGATION—An increase in the length of a material due to heating, stretching, hammering, and so forth.

EM—Electrician's Mate.

ENERGIZE—To put into operation electrically.

EROSION—Pitting or eating away of metal due to the action of steam, chemicals, water, or atmosphere.

ERRATIC—Operating in an unusual manner that may result in possible breakdown or failure.

FATIGUE—A major breakdown of the surface metal over a large area, resulting in the surface metal's becoming loose and detached from the base material.

FBR—Feedback Report.

FED LOG—Federal Logistic.

FLOLS—Fresnel Lens Optical Landing System.

FMSO—Fleet Material Support Office.

FOD—Foreign Object Damage.

FREEZING—Stopping of motion between two contacting surfaces because of lack of lubrication.

GALLING—Tearing away of a metal surface by friction.

HERTZ—Cycles per second.

HMR—Hazardous Material Report.

HONE—To grind with an abrasive stone to remove surface imperfections.

HUD—Heads-Up Display.

HYDRAULIC—That which is operated or moved by the use of pressurized fluid.

HYDROSTATIC TEST—A test to determine whether a part can withstand certain hydraulic pressures without deforming or leaking.

I-LEVEL—Intermediate level.

IC—Interior Communications.

ICCS—Integrated Catapult Control Station.

ICP—Inventory Control Point.

IEM—Inactive Equipment Maintenance.

ILARTS—Integrated Launch and Recovery Television Surveillance System.

IMA—Intermediate Maintenance Activity.

INSURV—Inspection and survey.

IPB—Illustrated Parts Breakdown.

IRAC—Interim Rapid Action Change.

JBD—Jet Blast Deflector.

JCN—Job Control Number.

JSN—Job Sequence Number.

LAGGING—The material used to insulate steam pipes or boilers to prevent the loss of heat by radiation.

LANG LAY—The lay in the strands and the lay in the rope are in the same direction.

LAY—That length of rope in which one strand makes one complete revolution about the core.

LOEP—List of Effective Pages.

MC—Maintenance Control.

MAF—Maintenance Action Form.

MAGNETIC PARTICLE INSPECTION—A nondestructive method of inspecting areas on or near the surface of iron or steel. The part is

magnetized and then sprinkled with iron powder to locate discontinuities, such as hairline cracks.

MALFUNCTION—Any failure of a system or component that prevents normal operation of the catapult.

MCRL—Master Cross Reference List.

MDS—Maintenance Data System.

MEGGER—An instrument used for checking the insulation of electrical cables.

MEGOHM—A unit of electrical resistance equal to a million ohms.

METCAL—Meteorology and Calibration (program).

MICROINCH—A unit of measurement equal to a millionth of an inch.

MIOCROMETER—A device used for measuring minute distances.

MILSTRIP—Military Standard Requisition and Issue Procedures.

MIP—Maintenance Index Page.

MISALINEMENT—The condition of not being along a fixed straight line; cocked to one side with respect to other parts.

MOVLAS—Manually Operated Visual Landing Aid System.

MR—Maintenance Requirement.

MRC—Maintenance Requirement Card.

MRIL—Master Repairable Item List.

MS—Maintenance Support.

NATTC—Naval Air Technical Training Center.

NATO—North Atlantic Treaty Organization.

NAVAIRWARCEN—Naval Air Warfare Center.

NAVSHIPYD—Naval Shipyard.

NAVSUP—Naval Supply System Command.

NDI—Non-destructive inspection.

NECKING-DOWN—A reduction in diameter, as in a bolt or stud, caused by wear from vibration of another part.

NGL—Nose Gear Launch.

NPC—Naval Personnel Command.

NSN—National Stock Number.

NTP—Navy Training Plan.

O-LEVEL—Organizational Level.

OHM—A measurement of electrical resistance.

OJT—On-the-job training.

OPNAV—Office of the Chief of Naval Operations.

OPTAR—Operations (or Operating) Target (funding).

OSI—Operating space item.

PARALLEL—Being arranged so that two or more lines, such as centerlines or lines along outside edges, can all be at right angles to one common line.

PEB—Pre-Expended Bin.

PEEN—To change the shape of a metal part by striking with a hammer.

pH NUMBER—A number used to measure the acidity or alkalinity of a solution; pH values run from 0 through 14. A value of 7 indicates neutrality; numbers less than 7 indicate acidity, and numbers greater than 7 indicate alkalinity.

PICKLE—To clean castings or forgings in a hot weak-sulfuric-acid bath.

PITTING—Small deep cavities with sharp edges. May be caused in metal surfaces by high impacts or by oxidation.

PME—Precision Measuring Equipment.

PMS—Planned Maintenance System.

PNEUMATIC—That which is operated or moved by the use of pressurized air.

POWER PACKAGE—Provides and maintains the hydraulic pressure to raise and lower the barricade stanchions.

PQS—Personnel Qualification Standards.

PRESSURIZE—To compress air or hydraulic fluid to a pressure greater than normal.

QA—Quality Assurance.

QAI—Quality Assurance Inspector.

QDR—Quality Deficiency Report.

RAC—Rapid Action Change.

REEVE—To pass a cable or rope through a sheave, hole, ring, or similar object.

REMOVAL TORQUE—The minimum torque required to remove an installed screw, measured with no axial load in the screw and while the screw is in motion.

SATURATED STEAM—Steam that contains moisture.

SAYBOLT SECONDS UNIVERSAL—A unit of measurement of fluid viscosity as determined by a Saybolt viscometer. (The higher the SSU number, the more viscous the fluid.)

SCORING—Deep grooves in a surface caused by rubbing when fine, hard particles are forced between moving surfaces (as in a bearing and journal), or when a moving part is not supplied with lubricant.

SE—Support Equipment.

SECDEF—Secretary of Defense.

SECNAV—Secretary of the Navy.

SECURE—Tighten joints or fasteners.

SEIZING—A wrapping, consisting of several turns of light line or wire, placed around the cut end of a wire rope to prevent the strands of the rope from unraveling.

SEIZING—The stopping of motion between two contacting surfaces because of lack of lubrication.

SFOMS—Ship's Force Overhaul Management System.

SFWP—Ship's Force Work Package.

SHEAR—A break in a part caused by an external pressure.

SHIPALT—Ship Alteration.

SI—Ship Installation.

SIMA—Shore Intermediate Maintenance Activity.

SLEP—Service Life Extension Program.

SM&R—Source, Maintenance, and Recovery Code.

SNAP—Shipboard Non-tactical ADP Program.

SPALLING OR FLAKING—A breakdown of the surface metal over a small area, resulting in the surface metal's becoming loose and detached from the base material.

SRA—Selected Restricted Availability.

STAKE—To spread the head of a fastener, while in place, with a center punch or similar tool to prevent rotation of the fastener.

STELLITE—A very hard metal composition used for facings.

STRAIN—That force within a part that is caused by an external pressure.

STRIP SIDE—The side of the launching-engine cylinders on which the sealing strip is located.

SUPERHEATED STEAM—Steam that is hotter than the boiling point of water and contains no moisture.

SWAGE—To make a binding between a fitting and wire rope by hammering the fitting until its diameter over the wire rope is reduced so that the fitting holds the wire rope tightly.

SWLIN—Ship's Work Line Item Number.

TAV—Technical Availability.

TCP—Tool Control Program.

TD—Technical Directive.

TFBR—Technical Feedback Report.

THERMAL—Relating to or caused by heat.

3-M—Maintenance and Material Management.

TMDER—Technical Manual Deficiency/Evaluation Report.

TOLERANCE—The amount of variation permitted in the size of a part.

TORQUE—A force applied to a part, using a twisting or rotating motion.

TPDR—Technical Publication Deficiency Report.

TPL—Technical Publications Library.

TYCOM—Type Commander.

UIC—Unit Identification Code.

VENT—To remove air or other gas or vapor from a system.

VIDS—Visual Information Display System.

V-RING PACKING—Chevron Packing.

VISCOSITY—Measure of resistance of a fluid to flow. (Thick liquids, such as syrup or glue, would have a higher viscosity than water.)

VLA—Visual Landing Aid.

VOLATILE—Passing off readily in the form of a vapor.

VR—Voyage Repair.

VRT—Voyage Repair Team.

W/C—Work Center.

WARNING—An emphatic notice requiring correct operating or maintenance procedures and the ensuring of safe conditions to prevent injury or loss of life.

WARPING—Bending or twisting out of shape.

WDC—Work Definition Conference.

WET STEAM—Steam mixed with free water particles.

APPENDIX II

REFERENCES USED TO DEVELOP THIS NONRESIDENT TRAINING COURSE

NOTE: Although the following references were current when this NONRESIDENT TRAINING COURSE was published, their continued currency cannot be assured. Therefore, you need to be sure that you are studying the latest revision.

Chapter 1

Blueprint Reading and Sketching, NAVEDTRA 12144, Naval Education and Training Professional development and Technology Center, Pensacola, Fla., 1994.

Use and Care of Hand Tools and Measuring Tools, NAVEDTRA 12085, Naval Education and Training Professional development and Technology Center, Pensacola, Fla., 1994.

Aircraft Launch and Recovery Equipment (ALRE) Tool Control Manual, NAEC-51-OR732.

Operational and Organizational/Intermediate Maintenance Manual with Illustrated Parts Breakdown, For All Shipboard Steam Catapults, NAVAIR 51-15ABB-4.1.

Chapter 2

Use and Care of Hand Tools and Measuring Tools, NAVEDTRA 12085, Naval Education and Training Professional development and Technology Center, Pensacola, Fla., 1994.

Aircraft Launch and Recovery Equipment (ALRE) Tool Control Manual, NAEC-51-OR732.

Chapter 3

Operational and Organizational/Intermediate Maintenance Manual with Illustrated Parts Breakdown, For All Shipboard Aircraft Recovery Equipment, NAVAIR 51-5BBA-2.1.

Operational and Organizational/Intermediate Maintenance Manual with Illustrated Parts Breakdown, For All Shipboard Aircraft Recovery Equipment, NAVAIR 51-5BBA-2.2.

Chapter 4

Operational and Organizational/Intermediate Maintenance Manual with Illustrated Parts Breakdown, For All Shipboard Steam Catapults, NAVAIR 51-15ABB-4.1.

Operational and Organizational/Intermediate Maintenance Manual with Illustrated Parts Breakdown, For All Shipboard Steam Catapults, NAVAIR 51-15ABB-4.2.

Operational and Organizational/Intermediate Maintenance Manual with Illustrated Parts Breakdown, For All Shipboard Steam Catapults, NAVAIR 51-15ABB-4.3.

Organizational and Intermediate Operation, Service, and Maintenance Instructions with Illustrated Parts Breakdown, Digital Endspeed Indicator System (DESI), NAVAIR 51-15ABE-2.

Chapter 5

Organizational/Intermediate Maintenance Manual with Illustrated Parts Breakdown, Jet Blast deflector, Mk7 Mod 0, Mk7 Mod 1, Mk7 Mod 2, NAVAIR 51-70-13.

Operational and Organizational/Intermediate Maintenance Manual with Illustrated Parts Breakdown, For All Shipboard Steam Catapults, NAVAIR 51-15ABB-4.3.

Operation, Service, Maintenance and Overhaul Instructions with Illustrated Parts Breakdown, Nose Gear Launch Equipment Mark 2 Mod 0 (Flush Deck Type), NAVAIR 51-25-19.

Chapter 6

Aircraft Launch and Recovery Equipment (ALRE) Tool Control Manual, NAEC-51-OR732.

The Aircraft Launch and Recovery Equipment Maintenance Program (ALREMP), OPNAVINST 4790.15 (Series).

Chapter 7

Ships Maintenance Material Management Manual (3-M), OPNAVINST 4790.4 (Series).

Naval Supply Procedures, Afloat Supply, Volume I, NAVSUP Publication 485.

Operational and Organizational/Intermediate Maintenance Manual with Illustrated Parts Breakdown, For All Shipboard Steam Catapults, NAVAIR 51-15ABB-4.1.

Operational and Organizational/Intermediate Maintenance Manual with Illustrated Parts Breakdown, For All Shipboard Aircraft Recovery Equipment, NAVAIR 51-5BBA-2.1.

APPENDIX III

ANSWERS TO REVIEW QUESTIONS

ANSWERS TO QUESTIONS FOR LESSON 1

- A1. The Tool Control Program is based on the concept of a family of specialized toolboxes and pouches configured for instant inventory before and after each maintenance action. The content and configuration of each container is tailored to the task, work center, and equipment maintained.
- A2. Good tool work habits include:
1. Keep each tool in its proper stowage place
 2. Keep tools in good condition
 3. Keep your tool allowance complete
 4. Use each tool only for the job it was designed to do
- A3. Striking tools include:
1. Ball peen hammer
 2. Cross peen hammer
 3. Riveting hammer
 4. Claw hammer
 5. Mallets and sledges
- A4. Machinists' hammers are used on metal and machinery. Soft-faced hammers are used when there is a danger of damaging the surface of the work, such as when pounding on a machined surface. Mallets are used to drive wooden-handled chisels, gouges, and wooden pins. Short-handled sledges are used to drive driftpins, large nails, and to strike cold chisels and small hand-held rock drills. Long-handled sledges are used break rock and concrete, to drive spikes or stakes, and to strike rock drills and chisels. Claw hammers are used for carpentry work.
- A5. Striking tools should be kept clean and free of oil. The heads should be dressed to remove any battered edges. A light film of oil should be kept on mallets to maintain a little moisture in the head. Hammer handles should be kept tight.
- A6. Do not use a hammer handle for bumping parts in assembly, and never use it as a pry bar. Do not strike a hardened steel surface with a steel hammer.
- A7. The different types of wrenches are open end, box, combination, socket, ratchet, torque and, adjustable, such as the union nut, pipe, and strap wrenches. There are also spanner and setscrew wrenches.
- A8. Wrenches are used to turn nuts, bolts, pipes, and setscrews.
- A9. The safety precautions that apply to wrenches are:
1. Always use a wrench that fits the nut properly
 2. Keep wrenches clean and free from oil
 3. Do not increase the leverage of a wrench by slipping a pipe over the handle
 4. Determine which way a nut should be turned before trying to loosen it

A10. The different types of metal-cutting tools are:

1. Snips and shears
2. Hacksaws
3. Chisels
4. Files
5. Twist drills
6. Punches
7. Taps and dies

A11. Hawks-bill snips are used for cutting circles

A12. Hacksaws are used to cut metal that is too heavy for snips or boltcutters.

A13. Taps and dies are used to cut threads in metal, plastics, or hard rubber.

A14. The different types of punches are:

1. Center punch
2. Prick punch
3. Drift or starting punch
4. Pin punch
5. Aligning punch
6. Hollow shank gasket punch

A15. The center punch is used to mark the center of a hole to be drilled.

A16. A prick punch is used to mark the intersection of two layout lines.

A17. The different types of taps are:

1. Taper
2. Plug
3. Bottoming
4. Pipe

A18. Taper taps are used for starting a tapping operation or for tapping through holes.

A19. The different types of dies are:

1. Rethreading dies
2. Round split adjustable dies
3. Two piece collet dies
4. Two piece rectangular pipe dies

A20. Two-piece rectangular pipe dies are used for cutting internal American Standard Pipe threads.

A21. Screw and tap extractors are used to remove screws and taps without damaging the material being worked on.

A22. Pipe cutters are used to cut pipe made of steel, brass, copper, wrought iron, or lead.

A23. Tube cutters are used to cut tubing made of iron, steel, brass, copper, or aluminum.

A24. Flaring tools are used to make flares in the ends of tubing.

A25. The different types of screwdrivers are the standard, clutch tip, Phillips, Reed and Prince, offset, and ratcheting.

A26. Safety precautions that apply to screwdrivers include:

1. Never use a screwdriver to check electrical circuits.
2. Never try to turn a screw driver with a pair of pliers.
3. Do not hold work in your hand while using a screwdriver.

A27. The different types of pliers are:

1. Slip-joint
2. Wrench
3. Water-pump
4. Groove-joint
5. Diagonal
6. Side-cutting
7. Duckbill pliers
8. Needle-nose
9. Wire-twister

A28. Wrench pliers are used for clamping and holding onto objects regardless of their shape.

A29. Side-cutting pliers are used for holding, bending, and cutting thin materials or small gauge wire.

A30. A small three-corner file is used to sharpen the serrations on the jaws of pliers.

A31. Mechanical fingers are used to retrieve small articles that have fallen into places that cannot be reached by hand.

A32. A standard Navy vaporproof two-cell flashlight belongs in every toolbox.

A33. Inspection mirrors are used to view areas that cannot be seen by a direct line of sight.

A34. Several principles that apply to the care of handtools are:

1. Clean tools after each use.
2. Never hammer with a wrench.
3. Never leave tools scattered about.
4. Apply a light film of oil after cleaning to prevent rust.
5. Inventory tools after each use to prevent loss.

A35. Personal safety equipment includes safety shoes, goggles, Gloves, and safety belts and straps.

A36. Common power tools include drills, Disk sanders, portable grinders, and electric impact wrenches.

A37. Although electric drills are designed for drilling holes, by adding accessories they can be adapted for sanding, sawing, buffing, polishing, screw driving, wire brushing, and paint mixing.

A38. Safety precautions that apply to power tools:

1. Ensure electrical tools are inspected and approved for shipboard use.
2. Wear safety goggles when using portable electric tools.
3. Rubber gloves must be worn when using portable electric tools under hazardous conditions.

- A39. Safety precautions that apply to extension cords:
1. Only use three-wire extension cords with three prong plugs.
 2. Plug the tool into the extension cord before the extension cord is plugged in.
 3. Replace damaged cords.
- A40. Portable pneumatic power tools include pneumatic chipping hammers, rotary and needle impact scalers, and portable pneumatic impact wrenches.
- A41. Rotary and needle impact scalers are used for removing rust, scale, and old paint from metallic and masonry surfaces.
- A42. Safety precautions that apply to pneumatic tools include:
1. Wear the appropriate protective devices.
 2. Only authorized and trained personnel should use pneumatic tools.
 3. Pneumatic tools should be laid down in such a way that no harm will be done if the switch is accidentally turn on.
 4. Never point the air hose at another person.
- A43. The title block is located in the lower right corner on all blueprints and drawings prepared to military standards.

ANSWERS TO QUESTIONS FOR LESSON 2

- A1. The different types of measuring tools are:
1. Rules and tapes
 2. Calipers
 3. Micrometer calipers
- A2. Steel or wooden straightedge rules are used for short measurements. Tape measures are used for longer measurements, up to 300 feet. Calipers are used in conjunction with a scale to determine the thickness or diameter of a surface, or the difference between surfaces.
- A3. Handle rules and tapes carefully, and keep metal rules lightly oiled. Keep calipers clean and lightly oiled.
- A4. The different types of micrometers are:
1. Outside micrometers, including screw thread micrometers
 2. Inside micrometers
 3. Depth micrometers
- A5. Outside micrometers are used to measure outside dimensions, such as the diameter of round stock or the thickness of flat stock. Screw thread micrometers are used to determine the pitch diameter of screws. Inside micrometers are used to measure the inside diameter of a pipe or hole. Depth micrometers are used to measure the depth of a hole or recess.
- A6. Keep micrometers clean and lightly oiled. Always keep micrometers in a case or box.
- A7. All measuring tools will be marked in some manner to comply with the standard inventory instructions found in OPNAVINST 4790.15.

ANSWERS TO QUESTIONS FOR LESSON 3

- A1. The constant runout control valve is considered the heart of the arresting engine.
- A2. The retract valve permits the return of hydraulic fluid from the accumulator to the main engine cylinder.
- A3. The capacity of the fluid stowage tank is 700 gallons.
- A4. The pitch diameter of the sheaves on the outboard shaft of the crosshead is 33 inches.
- A5. The drive system transfer energy from an arresting aircraft to the arresting engine.
- A6. The sheave damper reduces peak cable tension.
- A7. The differences between the pendant engine and the barricade engine are:
 - 1. No fluid coolers are installed.
 - 2. Barricade engines are endless reeved.
 - 3. No anchor dampers are installed.
 - 4. A short stroke control valve cam is used.
- A8. Multiple release straps connects the upper and lower loads straps to the barricade stanchions.
- A9. The counterbalancing springs are compressed when the stanchions are lowered.
- A10. The deck latch secures the barricade stanchions to the deck.
- A11. The power package accumulator operating pressure is 1500 psi.
- A12. Off, Automatic, and Run are the three position of the motor controller switch.
- A13. One inch is the minimum allowable clearance between the crosshead and the crosshead stop.
- A14. The age of all packing are based on the cure date.
- A15. The shelf life of V-ring packing is three years.
- A16. The open side of the packing face the pressure.
- A17. Hookrunner should approach the aircraft from the front and side.
- A18. Air in the main engine cylinder or the CRO valve not properly seated.
- A19. The barricade stanchions safety brace must be installed.
- A20. When the weight selector is set to light for the incoming aircraft two-blocking can occur.
- A21. Fast retraction is an indication of excessive accumulator pressure.

ANSWERS TO QUESTIONS FOR LESSON 4

- A1. The launching engine cylinders are heated by a pair of trough heaters located below each row of launching engine cylinders.
- A2. The trough steam smothering is actuated pneumatically by a valve located at deckedge or manually by a bypass located near the pneumatically operated steam supply valve.

- A3. The launch valve steam valve admits and shuts off the flow of steam to the launching engine cylinders during operation.
- A4. The launch valve stroke timer electrical system measures launch valve performance.
- A5. To prevent the exhaust valve from opening while the launch valve is open.
- A6. The shuttle assembly by means of a launch bar attached to the aircraft nose gear and connected to the catapult NGL spreader?
- A7. The lubrication system provides a means of lubricating the launching engine cylinders?
- A8. The retract permissive and maneuver aft circuit.
- A9. Capacity of 90 gallons.
- A10. The retraction engine and drive system is used to return the launching engine pistons and shuttle assembly to the battery position after each launch.
- A11. Control is divided between the ICCS and the CCP.
- A12. The deck edge signal box indicates the readiness of the catapult.
- A13. No loads are conducted during the accomplishment of preoperational MRCs and may also be required during post maintenance check out.
- A14. After 10 seconds.

ANSWERS TO QUESTIONS FOR LESSON 5

- A1. The operating gear assembly provides the means of physically raising and lowering the JBD panels.
- A2. The Mk 7 Mod 0 JBD consists of 14 tube assemblies.
- A3. The swivel joint permits rotational movement of the piping during raising and lowering of the JBDS.
- A4. The maximum temperature of the cooling water is 210°F.
- A5. The four-way control valve (stack valve) controls the hydraulic fluid to and from the hydraulic cylinders.
- A6. The stack valve is a four-way, solenoid controlled pilot operated valve.
- A7. The difference between the deckedge and the auxiliary panels is none, because they are identical.
- A8. The double indicator light indicates low cooling water pressure and high cooling water temperature.
- A9. The "all" raise switch permits raising and lowering of all JBD panels simultaneously.
- A10. The panel support is used to lock the JBD panels in the raised position for maintenance or emergencies.
- A11. The personnel required for an JBD emergency lowering are:
 1. Topside safety Petty Officer (overall in charge)
 2. Topside JBD phone talker
 3. Below decks phone talker/valve operator
 4. Two personnel to install emergency lowering device

5. Two safety observers (station at the port and starboard sides of the JBD panels)
6. Tractor driver

A12. The NGL guide tracks are:

1. Approach track
2. Buffer cylinder track
3. Aft slide-access track
4. Forward slide-access track
5. Forward track

A13. The slide is mechanically connected to the buffer cylinder piston rods by three links.

A14. The reset assembly resets the buffer hook.

A15. Inserts installed in the forward slide-access track ensures the launch bar makes contact with the buffer hook actuator roller.

A16. The orifice tube is located in the two outer cylinders.

A17. Fluid from the buffer accumulator assembly fills the void created as the piston rods move forward.

A18. The buffer fwd and buffer fwd pushbuttons are installed in the monitor control console, deckedge, and the central charging panel.

ANSWERS TO QUESTIONS FOR LESSON 6

A1. The three levels of maintenance are:

1. Organizational
2. Intermediate
3. Depot

A2. The concept of each level of maintenance is:

1. O-level: done by catapult and arresting gear personnel
2. I-level: done by designated maintenance activities in support of fleets units
3. Depot-level: maintenance that require the skills and facilities beyond O- and I- level maintenance

A3. The general types of maintenance are upkeep and overhaul.

A4. Maintenance control is the nerve center of the division maintenance effort.

A5. The distinct organizations within V-2 division are:

1. Operational
2. Maintenance group
3. Maintenance organization

A6. The columns that are required on the VIDS board are:

1. Work center designation
2. Inwork
3. AWM (awaiting maintenance)
4. AWP (awaiting parts)

A7. The ALRE MAF card is used to track all outstanding maintenance actions.

- A8. Color codes are used to annotate the priority section of the ALRE MAF card.
- A9. The ALRE MAF is divided into seven areas.
- A10. Copy 1 of the ALRE MAF is retained by QA.
- A11. The primary role of maintenance support is to assist operating work centers by providing technical expertise in performing maintenance and repairs on critical equipment.
- A12. The maintenance summary sheets must be retained for 2 years.
- A13. Benefits of the tool control program are:
1. Reduced initial outfitting and tool replacement costs
 2. Reduced tool pilferage
 3. Reduced man-hours required to complete each maintenance task
 4. Assurance that the proper tools are available to perform specific maintenance tasks
- A14. False: CDIs are assigned to their respective work centers.
- A15. The work center supervisor is responsible for ensuring that the proper level of QA inspection is assigned to a maintenance action.
- A16. QAIs and CDQAIs are designated in writing by the commanding officer.
- A17. The categories of QA audits are:
1. Work center
 2. Special
 3. Annual TYCOM

ANSWERS TO QUESTIONS FOR LESSON 7

- A1. Inactive Equipment Maintenance is maintenance performed when specific equipment will remain inactive for 30 days or longer and is not scheduled for repair, maintenance, or overhaul by either ship's force or an external repair activity.
- A2. The workcenter PMS manual contains only the planned maintenance requirements applicable to a particular workcenter.
- A3. The maintenance requirement card provides detailed procedure used to perform maintenance.
- A4. The cycle schedule displays the planned maintenance requirements to be performed during the period between major overhauls of the ship; that is, from the first quarter after overhaul to the next first quarter after a ship's overhaul.
- A5. All superseded cycle schedules are retained for 12 months.
- A6. The quarterly schedule is updated weekly.
- A7. The Maintenance Data System is used to record information considered necessary for workload planning and coordination and to provide a data base for evaluating and improving equipment installed in the fleet.
- A8. Under MDS, The job control number (JCN) consists of a five-character unit identification code (UIC), a four-character workcenter code, and a four-character serial number called the job sequence number (JSN).

- A9. The OPNAV 4790/2K is used to report all deferred maintenance actions and the completion of maintenance actions that do not result in configuration changes.
- A10. The maintenance planning and estimating form (OPNAV 4790/2P) is used along with the OPNAV 4790/2K form for deferring maintenance to be done by an intermediate maintenance activity (IMA).
- A11. The national stock number is made up of 13 digits.
- A12. The Federal Supply Classification number occupies the first part of the national stock number.
- A13. The cognizant (COG) symbol identifies the stores account and cognizant inventory manager of an item.
- A14. The Afloat Shopping Guide (ASG) is designed to assist the fleet personnel in identifying the NSNs for items that are frequently requested by ships.
- A15. The casualty report (CASREP) system contains four types of reports: Initial, Update, Correct, and Cancel.
- A16. The workcenter maintenance logs are retained for a minimum of two years.

INDEX

A

Accumulator and air flasks, 4-32
Accumulator system, 3-12
Adjustable wrenches, 1-25
 pipe, 1-26
 strap, 1-26
Aircraft launch and recovery equipment (ALRE)
Arresting engine, 3-4
 constant runout (CRO) control valve assembly,
 3-4
 control valve weight selector, 3-6
 electrical system, 3-8
 engine structure, 3-4
 the CRO drive system, 3-4
Arresting gear logs and reports, 7-43
 automated shot and recovery logs program, 7-45
 maintenance log, 7-43
 wire rope history report, 7-45
Automatic lubrication system, 3-19
Auxiliary air flasks, 3-16

B

Blueprints and drawings, 1-4
 lines, 1-5
 revision block, 1-4
 title block, 1-4
Bridle tensioning system, 4-29
Butterfly exhaust valve, 4-10
 pressure-breaking orifice elbow, 4-10

C

Cable anchor damper, 3-21
 battery positioner, 3-24
 cushioning piston, 3-23
Cable terminal proof-loading machine, 3-57
Calipers, 2-4
 combination firm-joint caliper, 2-6
 hermaphrodite, 2-5
 inside transfer firm-joint, 2-5
 outside calipers, 2-5
 spring-joint, 2-5
 transfer calipers, 2-5
Casualty reporting, 7-40
Catapult control systems, 4-44
Catapult trough covers, 4-23
Cognizant Symbol, 7-31
Configuration change, 7-27
Crosshead and fixed sheave installation, 3-18
Cycle schedule, 7-13
Cylinder and ram assemblies, 3-17

D

Deck gear, 3-28
 deck pendants, 3-31
 fairlead system sheaves, 3-28
 impact pads, 3-32
 retractable sheave, 3-28
 wire supports, 3-33
Dies, 1-34
 rethreading, 1-34
 square pipe, 1-34
 two piece collet, 1-35

E

Emergency recovery equipment, 3-34
 barricade power package, 3-42
 barricade stanchion winches, 3-39
 barricade webbing assembly, 3-35
 counterbalancing spring, 3-40
 deck ramp installation, 3-37
 deck winches, 3-39
 pendant and anchor installation, 3-39
 stanchion hydraulic cylinder, 3-39
 tensioning pendants, 3-39
Extractors, 1-42
 screw, 1-42
 tap, 1-42

F

Federal Catalog System, 7-30
Feedback report, 7-11
Flaring tools, 1-43
Fluid replenishment system, 3-13
Fluid stowage system, 3-14
 fluid cooler, 3-14

H

Hydraulic system, 4-31
Hydraulic-lock-valve panels, 4-12

I

Inspection mirror, 1-47

J

Jet blast deflectors, 5-1
 comparison, 5-2

L

- Launching engine system, 4-3
 - cylinder covers, 4-15
 - cylinder expansion and elongation indicators, 4-25
 - cylinder sealing strips, 4-16
 - launching cylinders, 4-15
 - sealing strip anchor and guide, 4-17
 - sealing strip tensioner, 4-17
 - shuttle, 4-18
 - steam piston assembly, 4-18
 - water-brake cylinders, 4-19
 - water-brake pressure-sensing switches, 4-21
 - water-brake pumps, 4-20
- List of Effective Pages, 7-2
 - force revision, 7-2
 - maintenance index page, 7-3
- Lubrication system, 4-27

M

- Maintenance log, 7-42
- Maintenance requirement description, 7-8
- Main hydraulic pumps, 4-33
 - rotary retraction engine, 4-35
- Maintain JBD equipment, 5-13
 - cleaning, 5-14
 - hoses, seals, and o-rings, 5-14
 - standard safety precautions, 5-14
- Maintenance procedures, 3-45
- Maintenance types, levels, and responsibilities, 6-1
 - depot maintenance, 6-2
 - intermediate maintenance, 6-1
 - organizational maintenance, 6-2
- Material control codes, 7-33
- Measuring tools, 2-1
 - rules and tapes, 2-1
- Mechanical fingers, 1-46
- Metal-cutting tools, 1-9
 - files, 1-13
 - hacksaws, 1-11
 - snips and shears, 1-9
- Microfilm/aperture cards, 1-8
- MK 2 nose-gear-launch system, 5-15
 - actuator reset assembly, 5-17
 - buffer accumulator, 5-18
 - buffer cylinder, 5-18
 - guide track, 5-15
 - shock absorber assembly, 5-20
- MK 7 MOD 0 jet blast deflector, 5-2
 - control system, 5-9
 - emergency procedures, 5-12
 - water-cooled panel assembly, 5-4

P

- Part number, 7-35
- Personal safety equipment, 1-2
 - belts and straps, 1-2
 - goggles, 1-2
 - safety shoes, 1-2

- Pipe cutter, 1-43
- Pliers, 1-18
 - duckbill, 1-29
 - needle-nose, 1-30
 - side-cutting, 1-29
 - slipjoint, 1-28
 - wire-twister, 1-30
 - wrench, 1-18
- PMS maintenance requirement status boards, 6-9
- Pneumatic tools, 1-40
 - clipping hammer, 1-40
 - impact wrench, 1-41
- Power tools, 1-37
 - disk sander, 1-38
 - drills, 1-37
 - impact scalers, 1-40
 - portable grinders, 1-38
- Punches, 1-32
 - aligning, 1-33
 - drift, 1-33
 - hollow shank gasket punch, 1-34
 - prick, 1-33
- Purchase cable, 3-27
- Push-button station, 3-9
 - control valve weight selector indicator circuit, 3-9
 - deckedge control, 3-9

Q

- Quality assurance, 6-13
 - audits, 6-16
 - inspector qualifications, 6-15
- Quarterly schedule, 7-16

R

- Recovery log, 7-43
- Repairables, 7-36
- Replacing packings, 3-63
 - general precautions, 3-64
 - gland installation, 3-59
 - installing new packings, 3-59
- Replacing purchase cable, 3-46
 - inspecting the terminal, 3-55
 - preparing and pouring zinc, 3-53
 - testing the terminal, 3-56
- Retracting valve, 3-10
 - plunger, 3-11
 - retracting lever, 3-11
 - valve body, 3-10
 - valve seat, 3-11
 - valve stem, 3-11
- Retraction system, 4-35
 - drum assembly, 4-36
 - screw and traverse carriage, 4-36

S

- Schematic diagrams, 1-8
 - electrical systems, 1-8
 - piping systems, 1-8

- Screwdrivers, 1-44
 - offset, 1-46
 - reed and prince, 1-45
 - standard, 1-44
- Setscrew wrenches, 1-26
 - allen, 1-26
 - bristol, 1-26
- Sheave damper, 3-24
- Socket handles, 1-23
 - sliding t-bar, 1-23
 - speedhandle, 1-23
- Spanner wrenches, 1-26
 - hook spanner, 1-26
 - pin spanner, 1-26
- Steam catapults, 4-1
 - description, 4-1
 - launching valve assemblies, 4-4
- Steam cutoff pressure-switch installation, 4-22
- Steam system, 4-1
 - capacity selector valve, 4-9
 - launching valve assembly, 4-4
 - launching-valve control valve, 4-9
- Striking tools, 1-30
 - ball-peen hammer, 1-31
 - machinists' hammers, 1-31

T

- Taps, 1-34
 - bottoming, 1-34

- plug, 1-34
- Tool Control Program, 1-1,6-13
 - care of hand tools, 1-2
- Toolbox flashlight, 1-47
- Torque wrenches, 1-23
 - deflecting beam, 1-24
 - dial indicating, 1-24
 - micrometer setting, 1-24
- Transfer switches, 4-49
 - integrated catapult control system (ICCS), 4-44

V

- V-2 maintenance organization structure and responsibility, 6-2
 - ALRE maintenance support, 6-12
 - maintenance control, 6-3
 - quality assurance branch, 6-13
- Visual information display system (VIDS), 6-4
 - maintenance action form (MAF) Cards, 6-7

W

- Walkback, 3-60
- Weekly schedule, 7-19
- Wrenches, 1-18
 - box, 1-21
 - combination, 1-21
 - open-end, 1-19
 - socket, 1-22

Assignment Questions

Information: The text pages that you are to study are provided at the beginning of the assignment questions.

ASSIGNMENT 1

Textbook Assignment: "Common Maintenance Tools and Their Uses," Pages 1-1 through 1-48; and "Measuring Tools and Techniques," Pages 2-1 through 2-12.

- 1-1. You demonstrate good work habits by doing which of the following tasks?
1. Stowing tools in their proper place
 2. Using handtools for their intended purposes only
 3. Protecting tools against damage, breakage, and rust
 4. All of the above
- 1-2. Ball-peen machinist's hammers are made in different weights. They are also divided into hard-faced and soft-faced classifications.
1. True
 2. False
- 1-3. Which of the following tools is most suitable for driving a tight fitting shaft into its hole?
1. A hard-faced hammer
 2. A soft-faced hammer
 3. A carpenter's hammer
 4. A sledge hammer
- 1-4. Which of the following statements best describes the effect of choking up on a hammer handle?
1. It increases the lever arm
 2. It reduces the striking force of the blow
 3. It produces a more effective blow
 4. It makes it easier to hold the hammer upright
- 1-5. Which of the following is a recommended practice in the use and care of a rawhide mallet?
1. It may be used to drive nails or strike steel surfaces
 2. The rawhide may be conditioned by exposure to sunlight
 3. The handle may be used for prying
 4. A light film of oil should be applied to the head before storage
- 1-6. What characteristic determines the size of an open-end wrench?
1. The overall length of the wrench
 2. The width of the opening between the wrench jaws
 3. The thickness of the wrench jaws
 4. The minimum amount of "play" between the jaws
- 1-7. The most frequently used box-end wrench has how many "points" or notches that contact the nut or bolt to be loosened or tightened?
1. 6
 2. 8
 3. 10
 4. 12
- 1-8. Which of the following wrenches is best suited for breaking a nut loose and then unscrewing it quickly?
1. An open-end "5" wrench
 2. A 15-degree offset open-end wrench
 3. A box-end wrench
 4. A combination box open-end wrench
- 1-9. A box-end wrench with a 15-degree offset has what advantage, if any, over a straight-handle box-end wrench?
1. The offset allows more handle swing
 2. Increased leverage
 3. The offset allows clearance over nearby parts
 4. None
- 1-10. Which of the following socket handle is used to rapidly tighten or loosen nuts or bolts using a series of partial turns?
1. Hinged handle
 2. Speed handle
 3. Ratchet handle
 4. Sliding T-bar handle

- 1-11. Which of the following socket handle is used for removing nuts or bolts that have been loosened first with another wrench?
1. Hinged handle
 2. Speed handle
 3. Ratchet handle
 4. Sliding T-bar handle
- 1-12. Which of the following socket handle is used for applying the most leverage to break loose tight nuts?
1. Hinged handle
 2. Speed handle
 3. Ratchet handle
 4. Sliding T-bar handle
- 1-13. When you are using a micrometer setting type torque wrench, how is the amount of torque applied indicated?
1. By pointer or needle movement
 2. The socket slips for a short distance
 3. An audible click and free movement of the handle for a short distance
 4. The user depends on a sense of touch or "feel" acquired through experience
- 1-14. What advantage is there to using an adjustable wrench instead of a box-end wrench to tighten or loosen a nut?
1. An adjustable wrench can be made to fit odd-sized nuts or bolts
 2. An adjustable wrench cannot damage hard to turn nuts
 3. An adjustable wrench is less likely to be used improperly
 4. Either jaw of an adjustable wrench may be adjusted to fit any size or shape nut or bolt
- 1-15. How should you guide straight hand tin snips when cutting light sheet metal, in relation to the layout line?
1. Guide snips on the inside of the line
 2. Guide snips on the outside of the line
 3. Guide snips directly on the line
 4. Guide snips either directly on the line or just inside of it
- 1-16. How are the teeth arranged on a double alternate set hacksaw blade?
1. They are arranged in short sections on each side of the blade
 2. They are arranged so that every third tooth is in line with the blade
 3. They are staggered in pairs, two to the left and two to the right
 4. They are staggered, one to the left and one to the right
- 1-17. What term denotes the groove cut through the head of a cap screw or machine bolt?
1. Guide
 2. Step
 3. Kerf
 4. Set
- 1-18. What chisel is used for cutting keyways and square corners?
1. Round nose
 2. Cape
 3. Flat
 4. Diamond point
- 1-19. What chisel is used for chipping inside corners?
1. Round nose
 2. Cape
 3. Flat
 4. Diamond point
- 1-20. What chisel is used for cutting V-grooves and sharp corners?
1. Round nose
 2. Cape
 3. Flat
 4. Diamond point
- 1-21. What chisel is used for cutting rivets and thin metal sheets?
1. Round nose
 2. Cape
 3. Flat
 4. Diamond point
- 1-22. Which of the following items should you wear when chipping metal with a chisel?
1. Canvas gloves
 2. A shop apron
 3. Safety goggles
 4. Rubber gloves

- 1-23. At what angle are the teeth of a single-cut file set?
1. 40°
 2. 65°
 3. 75°
 4. 90°
- 1-24. Alternate-position crossfiling is best suited to perform which of the following operations?
1. Filing round stock
 2. Polishing a flat surface
 3. Locating high and low spots
 4. Roughing a smooth surface
- 1-25. Rubbing chalk into the teeth of a file is the best method used to prevent "pinning" of the file.
1. True
 2. False
- 1-26. When polishing a metal surface with emery cloth, what substance should you apply to the surface?
1. Chalk dust
 2. Bright work polish
 3. Prussian blue
 4. Lubricating oil
- 1-27. What are the spiral grooves of a twist drill called?
1. The body
 2. The flute
 3. The shank
 4. The margin
- 1-28. What is the function of the lip on a twist drill?
1. To cut away the metal or wood being drilled
 2. To allow the twist drill to revolve without binding
 3. To center the twist drill
 4. To provide shank clearance
- 1-29. A center punch is used primarily to perform which of the following tasks?
1. To mark the center of a hole to be drilled
 2. To line up holes in mating assembly parts
 3. To free pins that are stuck or "frozen" in their holes
 4. To scribe layout lines
- 1-30. You have marked the intersection of two layout lines with a prick punch, but the punch mark is not at the exact center. How should you now center the punch mark?
1. Draw a new layout
 2. Select a new center point in the layout
 3. Make a second punch mark opposite of the first mark
 4. Slant the punch toward the intersection of the lines and enlarge the punch mark
- 1-31. Taps are used to cut internal threads, and dies are used to cut external threads in metal, plastics, and hard rubber.
1. True
 2. False
- 1-32. What sequence of taps should be used to tap a blind hole?
1. Plug, taper, bottoming
 2. Taper, bottoming, plug
 3. Plug, bottoming, taper
 4. Taper, plug, bottoming
- 1-33. A chamfer length of only 1 to 1 1/2 threads is found on what type of tap?
1. Taper
 2. Bottoming
 3. Plug
 4. Pipe
- 1-34. How should you make adjustments to a two-piece collet die?
1. Turn the collet cap
 2. Push a release button
 3. Turn setscrews
 4. Turn the guide
- 1-35. What is the cutting capacity of a number 2 pipe cutter?
1. 1 to 2 in.
 2. 1 1/2 to 3 in.
 3. 2 to 3 in.
 4. 2 to 4 in.
- 1-36. The single flaring tool is used to flare tubing ranging in what sizes?
1. 3/16 through 3/8 in. only
 2. 3/16 through 1/2 in.
 3. 1/4 through 7/16 in. only
 4. 1/4 through 1/2 in.

- 1-37. Standard screwdrivers are classified by size according to the combined length of which of their following parts?
1. Shank and blade only
 2. Handle and shank only
 3. Handle and blade only
 4. Handle, shank, and blade
- 1-38. How are combination slip-joint pliers distinguished from regular slip-joint pliers?
1. They have an adjustable pivot at the jaws
 2. They are able to hold objects regardless of their shape
 3. They have a side cutter at the junction of the jaws
 4. They have dual joints allowing a larger range of adjustment
- 1-39. Which type of pliers may be used as a clamp or vice?
1. Slip-joint pliers
 2. Water pump pliers
 3. Wrench pliers
 4. Groove-joint pliers
- 1-40. Of the following operations, which one is best accomplished by using diagonal pliers?
1. Grasping cylindrical objects
 2. Bending light gauge materials
 3. Cutting small objects flush with the surface
 4. Straightening bent cotter pins
- 1-41. What type of file should be used to sharpen the serrations on the jaws of pliers?
1. A dead smooth file
 2. A single cut flat file
 3. A small triangular file
 4. A small tapered square file
- 1-42. What is the maximum allowable length of an electric extension cord used on the flight deck?
1. 25 ft
 2. 50 ft
 3. 75 ft
 4. 100 ft
- 1-43. Which of the following pneumatic tools is best suited for use in scaling an irregular surface?
1. Rotary scaler
 2. Needle scaler
 3. Shale scaler
 4. Jitterbug scaler
- 1-44. Generally, pneumatic impact wrenches operate most efficiently when the air supplied is in what pressure range?
1. 50 to 80 psi
 2. 80 to 90 psi
 3. 80 to 100 psi
 4. 100 to 120 psi
- 1-45. The term "blueprint reading" is best defined by which of the following statements?
1. The reading aloud of the printed matter in the legends
 2. The reading of related matter to help you understand the blueprint symbols
 3. The interpretation of the ideas expressed on drawings
 4. The interpretation of your ideas compared to the ideas expressed on the drawing
- 1-46. In what corner of a blueprint is the revision block usually found?
1. Lower left
 2. Lower right
 3. Upper left
 4. Upper right
- 1-47. Of the following types of blueprints, which one would show the various parts of a machine and how the parts fit together?
1. Detail print
 2. Plan view
 3. Assembly print
 4. Unit print
- 1-48. How should a 12-inch steel rule be held to obtain an accurate measurement of a surface?
1. At a slight angle to the surface
 2. With the edge at a slight distance from the surface
 3. Flat along the surface
 4. With the edge along the surface

- 1-49. What is the most practical means of measuring the outside diameter of a pipe?
1. Trace the circumference of the pipe on a piece of paper and measure across the tracing
 2. Stop one end of a rule at the pipe edge, swing the rule, and read the maximum measure
 3. Stop one end of the rule at the pipe edge, swing the rule, and read the minimum measure
 4. Wrap a flexible rule around the pipe
- 1-50. Which of the following measuring tools is best used to measure the inside of a box frame or foot locker?
1. A folding rule with a sliding extension
 2. A carpenter's square
 3. An inside caliper
 4. A flexible tape rule
- 1-51. Which of the following tools should you use to take a measurement over a long distance?
1. A folding rule
 2. A folding rule with sliding extension
 3. A hook rule
 4. A fiberglass tape rule
- 1-52. Which type of inside calipers should be used to measure a chamfered cavity?
1. Transfer firm joint
 2. Adjustable firm joint
 3. Spring
 4. Hermaphrodite
- 1-53. Which type of calipers should be used to locate the center of a shaft?
1. Transfer
 2. Hermaphrodite
 3. Inside
 4. Outside
- 1-54. Which of the following calipers may be used to make inside and outside measurements?
1. Combination firm joint
 2. Solid-joint
 3. Spring
 4. Adjustable firm joint
- 1-55. What type of micrometer is used to measure the diameter of solid round bar?
1. Inside
 2. Outside
 3. Depth
 4. Screw thread
- 1-56. What type of micrometer is used to measure the pitch diameter of a screw?
1. Inside
 2. Outside
 3. Depth
 4. Screw thread
- 1-57. What type of micrometer is used to measure the bore of a cylinder?
1. Inside
 2. Outside
 3. Depth
 4. Screw thread
- 1-58. What type of micrometer is used to measure piston travel in a cylinder?
1. Inside
 2. Outside
 3. Depth
 4. Screw thread
- 1-59. Each of the 25 marks on the thimble of the standard outside micrometer represents what part of an inch?
1. 0.001 in.
 2. 0.005 in.
 3. 0.025 in.
 4. 0.040 in.
- 1-60. What characteristic of a micrometer determines its range?
1. The length of its frame
 2. The distance that the spindle can travel
 3. The distance that the spindle travels with each revolution of the thimble
 4. The length of the work it will measure

(THIS PAGE IS INTENTIONALLY LEFT BLANK.)

ASSIGNMENT 2

Textbook Assignment: "Mark 7 Aircraft Recovery Equipment and Emergency Recovery Equipment," Pages 3-1 through 3-63.

- 2-1. The Mk 7 recovery equipment is divided into a total of how many major systems?
1. Five
 2. Two
 3. Three
 4. Four
- 2-2. What is the purpose of the Mk 7 arresting engine constant runout control (CRO) valve?
1. To control fluid flow from the engine cylinder to the accumulator
 2. To control the hydraulic pressure maintained in the accumulator
 3. To reduce peak tension on the purchase cables during arrestment
 4. To allow equal payout of both ends of the deck pendant
- 2-3. The aircraft weight selector is adjusted while the arresting engine is in the battery position. This adjustment causes a change in the position of what component of the CRO valve?
1. The cam
 2. The plunger
 3. The upper lever
 4. The lower lever
- 2-4. Which of the following statements is correct concerning the valve sleeve and stem movement of the CRO valve?
1. At a 1:1 ratio, the sleeve and stem move 1/4 in.
 2. At a 1:1 ratio, the sleeve and stem move 1/2 in.
 3. At a 4:1 ratio, the sleeve and stem move 1/2 in.
 4. At a 4:1 ratio, the sleeve and stem move 1/4 in.
- 2-5. What controls the variation in the size of the opening of the CRO valve?
1. The drive system
 2. The aircraft weight selector setting
 3. The cam rotation
 4. The plunger movement
- 2-6. What is the purpose of the four vertical elongated holes machined into the retract valve seat?
1. To allow fluid to pass through the valve from the main engine cylinder
 2. To allow fluid to pass through the valve from the accumulator
 3. To allow fluid to pass through the valve from the anchor dampers
 4. To minimize the weight of the valve
- 2-7. Which of the following statements best describes the action of the return spring of the retract valve retraction lever?
1. The spring pulls up on the retract lever, which in turn pulls down on the plunger and valve stem
 2. The spring pulls up on the retract lever, which in turn pulls up on the plunger and valve stem
 3. The spring pulls down on the retract lever, which in turn pulls down on the plunger and valve stem
 4. The spring pulls down on the retract lever, which in turn pulls up on the plunger and valve stem
- 2-8. What device is installed on the retract valve operating lever to eliminate chatter?
1. A return spring and tie rod
 2. A plunger
 3. A shock absorber
 4. A 6-inch-square neoprene impact pad
- 2-9. The Mk 7 Mod 3 arresting engines have what is described as a recirculating type hydraulic system.
1. True
 2. False

- 2-10. The accumulator fluid indicator will indicate what reading, if any, if the piston striker rod is NOT in contact with the actuator rod?
1. Drain
 2. Fill
 3. Battery
 4. None; no reading will be indicated
- 2-11. What position must the arresting engine crosshead be in when you check the engine accumulator fluid level?
1. Drain
 2. Fill
 3. Off
 4. Battery
- 2-12. What is the purpose of the fluid replenishment system?
1. To replace or remove small amounts of fluid in the hydraulic system
 2. To replace large amounts of fluid lost due to leakage
 3. To provide a means of hydraulically setting the CRO valve
 4. To allow adjustment of the battery position of the crosshead
- 2-13. Which of the following statements regarding the fluid stowage system is INCORRECT?
1. Each arresting engine has its own stowage tank
 2. The tank is common to all arresting engines
 3. The tank can stow all the fluid from one arresting engine
 4. The capacity of the tank varies depending on the engine modification
- 2-14. What devices prevent corrosion of the cooling tubes in the fluid cooler?
1. Copper baffles
 2. Replaceable anodes
 3. Replaceable cathodes
 4. Rust inhibitors
- 2-15. Which components make up the actual engine of the arresting gear?
1. The crosshead and ram assembly
 2. The CRO valve and drive system
 3. The CRO valve, cylinder, and fixed end
 4. The cylinder and ram assembly
- 2-16. The outer end of the ram is attached to the crosshead by what device(s)?
1. A snap ring
 2. A bearing sleeve and retainer
 3. A split flange
 4. Pressure clamps
- 2-17. Which of the following parts enable lubricant to be retained in the cage and roller bearing assemblies of the crosshead sheaves and the sheaves of the fixed sheave installation?
1. Leather spacers
 2. Phenolic spacers
 3. Steel spacers
 4. Inner steel disc spacers
- 2-18. What purpose do the crosshead mounted slip-pers serve during arresting engine operation?
1. They absorb shock
 2. They support the crosshead
 3. They guide the crosshead
 4. They act as a bearing surface
- 2-19. What is the operating pressure of the automatic lubrication system?
1. 70 to 80 psi
 2. 75 to 85 psi
 3. 60 to 70 psi
 4. 40 to 50 psi
- 2-20. What is the proper amount of spring tension to be maintained on the hose reel of the automatic lubrication system?
1. 20 lb \pm 1/2 lb
 2. 14 lb \pm 1 lb
 3. 9 lb \pm 1/2 lb
 4. 5 lb \pm 1 lb
- 2-21. What is the function of the cable anchor damper?
1. To reduce vibration in the cable system by eliminating cable slack between the crosshead and fixed sheave assembly during retraction
 2. To reduce vibration in the purchase cable system by eliminating cable slack between the crosshead and fixed sheave assembly at the beginning of an arrestment
 3. To provide a means of anchoring the purchase cable in the engine room
 4. To indicate that the arresting engine has returned to the battery position after arrestment

- 2-22. What source provides the energy for the battery positioner to operate?
1. Hydraulics
 2. Electricity
 3. Pneumatics
 4. Electrohydraulics
- 2-23. Which of the following is NOT a part of the sheave damper assembly?
1. The anchor assembly
 2. The buffer assembly
 3. The charging panel
 4. The damper piston
- 2-24. What is the purpose of the sheave damper flow control valve?
1. To allow free flow of fluid from the damper cylinder to the damper accumulator and a restricted flow from the damper accumulator to the damper cylinder
 2. To allow restricted flow of fluid from the damper cylinder to the damper accumulator and free flow from the damper accumulator to the damper cylinder
 3. To allow free flow of fluid to and from the damper accumulator only
 4. To allow free flow of fluid from the damper cylinder to the accumulator only
- 2-25. What is the primary function of the purchase cables?
1. To transmit the landing aircraft's force to the arresting engine
 2. To tension the crossdeck pendant
 3. To drive the control systems of the arresting engine
 4. To retract the crossdeck pendant
- 2-26. If the purchase cable payout is 72 feet, the engine ram will travel a total of how many feet?
1. 5
 2. 2
 3. 3
 4. 4
- 2-27. What two methods can be used to operate the retractable deck sheaves?
1. Hydraulically and manually
 2. Pneumatically and manually
 3. Electrically and manually
 4. Hydraulically and pneumatically
- 2-28. The adjustable torque limit switch is actuated by which of the following components?
1. The worm
 2. The tripping plate washer
 3. The torque spring
 4. The wormshaft
- 2-29. What is the only function of the retractable deck sheave limit bevel gear?
1. To transmit the motor force to the wormshaft
 2. To engage the lugs of the clutch bevel gear
 3. To rotate the sleeve
 4. To turn the pinion of the geared limit switch
- 2-30. The crossdeck pendant cable ends are equipped with what type of terminals?
1. Swaged
 2. Poured basket
 3. Fiege
 4. Clamp
- 2-31. Wire supports are designed to maintain a crossdeck pendant height of 2 inches minimum. The maximum height should be measured between what two points?
1. From the top of the pendant to the deck at the pendant's highest point
 2. From the top of the pendant to the deck at the pendant's lowest point
 3. From the bottom of the pendant to the deck at the pendant's highest point
 4. From the bottom of the pendant to the deck at the pendant's lowest point
- 2-32. Which of the following components is/are NOT found in a barricade arresting engine installation?
1. Crossdeck pendant
 2. Sheave dampers
 3. Retractable sheaves
 4. Fluid cooler
- 2-33. The polyurethane semicoated barricade webbing assembly consists of a total of how many separate webbing systems?
1. Five
 2. Six
 3. Three
 4. Four

- 2-34. What raises and lowers the barricade stanchions?
1. Hydraulic cylinder
 2. Counterbalancing springs
 3. Tensioning pendants
 4. Stanchion latch
- 2-35. What cushions the barricade stanchions fall against the deck?
1. Hydraulic cylinder
 2. Counterbalancing springs
 3. Tensioning pendants
 4. Stanchion latch
- 2-36. What secures the barricade stanchions in the down position?
1. Hydraulic cylinder
 2. Counterbalancing springs
 3. Tensioning pendants
 4. Stanchion latch
- 2-37. What is the approximate fluid capacity of the barricade power package gravity tank?
1. 75 gal
 2. 125 gal
 3. 150 gal
 4. 200 gal
- 2-38. Which parts of the barricade power package hydraulic control system operate in conjunction to maintain accumulator pressure within specified limits?
1. Air charging valve and motor controller
 2. Motor controller and gauge valve
 3. Pressure sensing switch and motor controller
 4. Pressure sensing switch and air charging valve
- 2-39. At what approximate pressure will the safety head in the power package accumulator rupture?
1. 1,500 psi
 2. 1,600 psi
 3. 1,750 psi
 4. 2,000 psi
- 2-40. Of the two broad maintenance categories, corrective maintenance is preferred over preventive maintenance.
1. True
 2. False
- 2-41. Newly installed hydraulic seals should be pressure tested for at least how long before recovery operations are resumed?
1. 90 min
 2. 60 min
 3. 45 min
 4. 30 min
- 2-42. What condition will result from the stretching of newly installed purchase cables?
1. It causes the crosshead to move away from the crosshead stop, increasing the fluid capacity of the hydraulic system
 2. It causes the crosshead to move away from the crosshead stop, decreasing the fluid capacity of the hydraulic system
 3. It causes the crosshead to move toward the crosshead stop, increasing the fluid capacity of the hydraulic system
 4. It causes the crosshead to move toward the crosshead stop, decreasing the fluid capacity of the hydraulic system
- 2-43. When must newly installed purchase cables be detorqued?
1. Between the first 50 to 60 landings and every 200 thereafter
 2. After the first 60 landings and every 300 thereafter
 3. Before 50 landings are reached and every 150 thereafter
 4. At the discretion of the maintenance officer
- 2-44. After the wire rope has been cut, what is the next step in preparing it for terminal pouring?
1. Clean the end with chlorinated degreasing solvents
 2. Straighten the strands
 3. Remove the seizing from the cut end
 4. Remove the appropriate amount of the hemp center
- 2-45. What solvent is used to degrease and clean the broomed out end of the wire rope?
1. GRISOLVE PEG-2
 2. ZINC CHLORIDE
 3. TRICHLOROETHANE
 4. AMMONIUM CHLORIDE

- 2-46. In terminal pouring, when, if ever, must the solution in the ultrasonic degreaser and the rinsing solution be replaced?
1. Replace both solutions after 10 terminals have been degreased and rinsed
 2. Replace the solutions only when they become dirty
 3. Replace the degreasing solution after 10 terminals have been degreased; no limit on the rinse solution
 4. Never; strain both solutions through 100 micron screen after each use and they may be used indefinitely
- 2-47. The grit blast cabinet used for etching the wire rope cables and terminals should be filled with how much grit prior to use?
1. 100 lb maximum
 2. 100 to 200 lb
 3. 200 lb minimum
 4. 200 to 250 lb
- 2-48. The flux solution used in terminal pouring should be heated to what temperature range?
1. 550 to 600°F
 2. 460 to 510°F
 3. 250 to 280°F
 4. 160 to 210°F
- 2-49. Before the molten zinc is poured into a terminal, the terminal must be heated to what temperature range?
1. 500 to 550°F
 2. 550 to 600°F
 3. 778 to 798°F
 4. 950 to 1000°F
- 2-50. In terminal pouring, when, if ever, must the solution in the ultrasonic degreaser and the rinsing solution be replaced?
1. Replace both solutions after 10 terminals have been degreased and rinsed
 2. Replace the solutions only when they become dirty
 3. Replace the degreasing solution after 10 terminals have been degreased; no limit on the rinse solution
 4. Never; strain both solutions through 100 micron screen after each use and they may be used indefinitely
- 2-51. When repacking a component, how much clearance should be maintained to allow the packing freedom of movement?
1. 5/32 to 8/32 in.
 2. 3/32 to 5/32 in.
 3. 3/64 to 3/8 in.
 4. 1/64 to 3/64 in.
- 2-52. The proper procedure used to proofload a poured terminal is to gradually increase the test pressure to 200,000 pounds, hold the pressure for 2 minutes, and then gradually bleed down the pressure.
1. True
 2. False
- 2-53. What hazardous condition may be caused by entrapped air in the arresting engine cylinder?
1. Two-blocking
 2. Fast cable retraction
 3. Walkback
 4. Short runout
- 2-54. Of the following conditions, which one is considered extremely critical?
1. One broken wire in a crossdeck pendant
 2. Debris near a deck winch
 3. Sheaves slipping on races
 4. Terminals jamming sheaves
- 2-55. Improper CRO valve cam alignment will cause which of the following conditions?
1. The actual setting of the valve will be different from that indicated by the weight selector
 2. Main engine cylinder pressure will increase above 650 psi during arrestment
 3. An accumulator pressure will be lower than its initial charging pressure
 4. The CRO valve will always fully close prior to the aircraft's desired full runout

(THIS PAGE IS INTENTIONALLY LEFT BLANK.)

ASSIGNMENT 3

Textbook Assignment: "Steam Catapults," Pages 4-1 through 4-67.

- 3-1. What are the most significant differences among the various types of steam catapults?
1. Power strokes and lengths
 2. Endspeeds and power strokes
 3. Endspeeds and launching capacities
 4. Lengths and launching capacities
- 3-2. What switch or valve controls the flow of steam from the ship's boilers to the catapult's wet-steam accumulator?
1. The steam launching valve
 2. The capacity selector valve
 3. The steam fill valve
 4. The steam pressure cutoff switch
- 3-3. How far must the launch valve control assembly crosshead travel to stop the number 2 launch valve stroke timer clock?
1. 3 1/2 in.
 2. 6 in.
 3. 9 in.
 4. 11 1/2 in.
- 3-4. What device controls the opening rate of the launch valves to allow the launching of various types and weights of aircraft?
1. The launch valve control valve
 2. The capacity selector valve
 3. The launch valve stroke timers
 4. The steam pressure cutoff switch
- 3-5. What mechanism prevents a steam buildup behind the launching engine steam pistons?
1. The exhaust valve
 2. The pressure-breaking orifice elbow
 3. The exhaust valve keeper valve
 4. The wet-steam accumulator
- 3-6. The exhaust valve hydraulic lock valve controls the flow of fluid to which of the following components?
1. The steam pressure cutoff switch
 2. The pressure breaking elbow
 3. The exhaust valve limit switch
 4. The exhaust valve hydraulic actuator
- 3-7. What determines the number of launching cylinders that are mounted in the catapult trough?
1. Overall length of the catapult
 2. Required amount of elongation for the type of catapult
 3. Number of base pads in the trough
 4. Number of lubricator nozzles required for the type of catapult
- 3-8. What function is provided by the cylinder covers of the launching engine?
1. Eliminates the need for external bracing of the trough covers and track assembly
 2. Prevents steam from escaping through the cylinder slots during the power stroke
 3. Prevents steam pressure from spreading the cylinder in the area of the cylinder slot
 4. Provides a means of connecting the shuttle to the piston assemblies
- 3-9. What force maintains the tension on the catapult launching engine cylinder sealing strip?
1. Hydraulic pressure
 2. Spring tension
 3. Steam pressure
 4. Air pressure
- 3-10. What component serves as the chassis for the other components of the steam piston assembly?
1. The spear
 2. The barrel
 3. The connector
 4. The support guide
- 3-11. What prevents the loss of steam from behind the steam piston assemblies during the catapult's power stroke?
1. Segmented seals
 2. Piston rings
 3. The piston barrel
 4. Bushings

- 3-12. What component serves as a bearing surface for the piston assembly?
1. The rubbing strip
 2. The barrel
 3. The piston guide
 4. The strip guide
- 3-13. A total of how many rollers are mounted on the shuttle frame?
1. Six
 2. Two
 3. Eight
 4. Four
- 3-14. What component of the water brake cylinder installation forms the vortex at the open end of the water brake cylinder?
1. The jet ring
 2. The striker ring
 3. The annulus ring
 4. The choke ring
- 3-15. The term "elbow pressure" refers to what specific pressure?
1. The basket strainer inlet pressure
 2. The basket strainer outlet pressure
 3. The water pressure entering the water brake cylinder
 4. The pump discharge pressure
- 3-16. The contacts of the steam cutoff pressure switches close when the steam pressure in the launching engine cylinders reaches what pressure?
1. 10 psi
 2. 20 psi
 3. 30 psi
 4. 40 psi
- 3-17. All catapult trough covers are designed to withstand what total amount of vertical rolling shuttle load?
1. 100,000 lb
 2. 132,000 lb
 3. 200,000 lb
 4. 264,000 lb
- 3-18. Which of the following information is NOT displayed on the Digital Endspeed Indicator (DESI)?
1. Time of day
 2. CSV setting
 3. Shuttle endspeed
 4. Catapult number
- 3-19. The bridle tensioner fully aft limit switch is part of two catapult electrical circuits. One is the retract permissive circuit. What is the other one?
1. The maneuver forward
 2. The maneuver aft
 3. The military power
 4. The suspend circuit
- 3-20. Which of the following conditions would indicate a water loss in the catapult hydraulic fluid?
1. An increase in ph number
 2. A decrease in ph number
 3. An increase in viscosity
 4. A decrease in viscosity
- 3-21. What is the function of the catapult main hydraulic pump delivery control unit?
1. To direct fluid to the gravity tank when the pump is on stroke only
 2. To direct fluid to the accumulator when the pump is off stroke only
 3. To direct fluid to the accumulator when the pump is on stroke and to the gravity tank when the pump is off stroke
 4. To direct fluid to the accumulator when the pump is off stroke and to the gravity tank when the pump is on stroke
- 3-22. The motion of the rotary retraction engine hydraulic motor is transferred to the drive system cables by what assembly?
1. The traverse carriage assembly
 2. The crosshead assembly
 3. The sheave and adapter assembly
 4. The drum assembly
- 3-23. Which of the following components prevents the cables from becoming crossed and tangled on the drum?
1. The cable tensioner assembly
 2. The screw and traverse carriage assembly
 3. The fairlead sheave assembly
 4. The cable tensioner sheave assembly

- 3-24. The forward motion of the rotary retraction engine is stopped at the completion of the grab advance cycle by what force or device?
1. By cable dead weight drag
 2. By fluid acting on the carriage assembly
 3. By the advance buffer
 4. By fluid braking of the hydraulic motor
- 3-25. What is the function of the rotary retraction engine maneuvering valve?
1. To protect the engine from damage in the event of a malfunction
 2. To control the bridle tensioner control valve
 3. To control the speed of the grab after advance or retract stroke braking has been completed
 4. To initiate the advance and retract stroke braking
- 3-26. Which of the following components operates hydraulically to keep the retraction engine cables taut?
1. The cable tensioner assembly
 2. The screw and traverse carriage assembly
 3. The lead sheave assembly
 4. The cable tensioner sheave assembly
- 3-27. Which of the following components guides the cables between the retraction engine and the catapult trough?
1. The cable tensioner assembly
 2. The screw and traverse carriage assembly
 3. The fairlead sheave assembly
 4. The cable tensioner sheave assembly
- 3-28. The retraction engine drive system cables are attached to what component(s)?
1. The shuttle only
 2. The grab only
 3. The shuttle and launching engine steam pistons
 4. The grab and launching engine steam pistons
- 3-29. During normal launching operations, when will the grab release the shuttle?
1. When endspeed has been reached and the unlocking mechanism is disengaged
 2. When launch complete is reached and the locking mechanism is actuated
 3. When both have returned to battery position and the unlocking mechanism is actuated
 4. When maximum load drag weight is reached and the unlocking mechanism automatically disengages
- 3-30. Which of the following controls is NOT a momentary contact push button?
1. Fire
 2. Maneuver aft
 3. Lube
 4. Maneuver forward
- 3-31. The controls for the integrated catapult control system (ICCS) are mainly divided between or among how many control stations?
1. Five
 2. Two
 3. Three
 4. Four
- 3-32. The malfunction and status lights are located on what panel or console of the ICCS?
1. The central panel
 2. The cat officer control console
 3. The emergency deckedge control console
 4. The monitor panel
- 3-33. What panel controls and monitors the pneumatic system?
1. The left front panel
 2. The left intermediate front panel
 3. The right intermediate front panel
 4. The right front panel
- 3-34. What panel controls and monitors the hydraulic system?
1. The left front panel
 2. The left intermediate front panel
 3. The right intermediate front panel
 4. The right front panel

- 3-35. What panel provide emergency operational capacity?
1. The left front panel
 2. The left intermediate front panel
 3. The right intermediate front panel
 4. The right front panel

QUESTIONS 36 THROUGH 38 APPLY TO NON-ICCS.

- 3-36. What main control console panel indicates the status of various catapult system pressures?
1. The steam panel
 2. The emergency panel
 3. The monitor panel
 4. The operating panel
- 3-37. What main control console panel is used to control the catapult fill valves?
1. The steam charging panel
 2. The emergency panel
 3. The auxiliary deckedge panel
 4. The operating panel
- 3-38. What main control console panel contains all lights, switches, and pushbuttons that are found on the deckedge panel?
1. The gauge panel
 2. The emergency panel
 3. The auxiliary deckedge panel
 4. The operating panel
- 3-39. What indicates the catapult readiness to the launching officer during operations?
1. The gauge box
 2. The monitor panel
 3. The deckedge signal box
 4. The operating panel
- 3-40. The hydraulic fluid supply is shut off to what valve during the firing of no-loads?
1. The bridle tension regulator valve
 2. The maneuver aft valve
 3. The lubrication valve
 4. The advance valve

QUESTIONS 41 THROUGH 44 APPLY TO PROCEDURES FOR ICCS.

- 3-41. What personnel gives the tension signal to the catapult director?
1. The launching officer
 2. The deckedge operator
 3. The catapult safety observer
 4. The topside safety petty officer
- 3-42. What personnel signal the launching officer to take tension?
1. The catapult director
 2. The deckedge operator
 3. The catapult safety observer
 4. The topside safety petty officer
- 3-43. What personnel signals suspend to the launching officer?
1. The launching officer
 2. The deckedge operator
 3. The catapult safety observer
 4. The topside safety petty officer
- 3-44. On ships where the ICCS is the primary mode of controlling catapult launching operations, who depresses the FIRE push button to launch an aircraft?
1. The launching officer
 2. The deckedge operator
 3. The catapult safety observer
 4. The central charging panel operator

QUESTIONS 45 THROUGH 48 APPLY TO PROCEDURES FOR NON-ICCS.

- 3-45. Under normal launching conditions, what should be the last word(s) spoken over the sound powered phones?
1. FIRST READY
 2. TAKING TENSION
 3. FINAL READY
 4. FIRE
- 3-46. What signal is used by the deckedge operator to indicate that the FINAL READY light has come on at the deckedge panel and the catapult is in the FINAL READY condition?
1. Both hands are held open and above the head
 2. One hand is held open and above the head
 3. One hand is held above the head with two fingers extended
 4. Both hands are held above the head with only the index fingers extended

3-47. Which of the following actions must the deckedge operator take after receiving the FIRE signal from the catapult officer?

1. Immediately push the FIRE push button
2. Hesitate for at least 10 seconds to ensure that the aircraft is at full power, then push the FIRE push button
3. Notify the console operator that he is firing the catapult, then push the FIRE push button
4. Perform a final safety scan of the flight deck and catwalks, then push the FIRE push button

3-48. What immediate action must be taken by the deckedge operator if the catapult officer signals a hangfire?

1. Push the MANEUVER AFT push button to release bridle tension
2. Tell the console operator to actuate the SUSPEND switch
3. Close the EMERGENCY cutout valve and then actuate the SUSPEND switch
4. Actuate the SUSPEND switch and tell the console operator to ROTATE THE EMERGENCY CUTOUT VALVE, ROTATE THE EMERGENCY CUTOUT VALVE

(THIS PAGE IS INTENTIONALLY LEFT BLANK.)

ASSIGNMENT 4

Textbook Assignment: "Associated Launching Equipment," Pages 5-1 through 5-23; and "The Aircraft Launch and Recovery Equipment Maintenance Program (ALREMP)," Pages 6-1 through 6-18.

- 4-1. The Mk 7 Mod 0/2 JBD consists of a total of how many panel assemblies?
1. Six
 2. Two
 3. Eight
 4. Four
- 4-2. A total of how many hydraulic cylinders are used to raise and lower each pair of JBD panels?
1. Six
 2. Two
 3. Eight
 4. Four
- 4-3. The removable module assemblies are attached to the JBD panel assembly by what devices?
1. Welds
 2. Clamps
 3. Edge-fitted brackets
 4. Screws
- 4-4. What devices control the flow of cooling water through the Mk 7 JBD panel module assemblies?
1. Throttle valves
 2. Vacuum breaker valves
 3. Orifices
 4. Manual hand valves
- 4-5. The JBD cooling water must be maintained at what minimum pressure?
1. 60 psi
 2. 70 psi
 3. 80 psi
 4. 90 psi
- 4-6. The emergency lowering hydraulic bypass lines permit fluid to bypass what component of the JBD hydraulic system?
1. The lowering side of the hydraulic cylinder
 2. The solenoid manual override
 3. The stack valve
 4. The gravity tank
- 4-7. JBD control is transferred from the portable control box to the auxiliary control panel by what switch?
1. A manual override switch
 2. The defeat interlock switch
 3. The portable control box suspend switch
 4. A rotary type switch
- 4-8. In the event of an electrical power failure, how may the Mk 7 JBDs be raised or lowered?
1. By the auxiliary control panel
 2. By the portable control box group UP-DOWN toggle switch
 3. By the manual override on the four-way control valves
 4. By a tow tractor and cable
- 4-9. When it is necessary to remove a component from the hydraulic system, you should cap or plug the open lines to prevent foreign matter contamination.
1. True
 2. False
- 4-10. What is/are the advantage(s) of the nose gear launch system over the conventional launch system?
1. It permits positive engagement of the aircraft to the catapult
 2. It minimizes the number of personnel required to be near the aircraft during hookup operations
 3. It permits automatic engagement of the aircraft to the catapult
 4. All of the above
- 4-11. Inserts in the NGL guide track ensure that the aircraft launch bar makes positive contact with which of the following components?
1. The slide
 2. The buffer hook actuator roller
 3. The track seal
 4. The soft-stop buffer

- 4-12. What component of the Mk 2 NGL system engages the aircraft holdback bar as the aircraft taxis into position for launch?
1. The buffer hook
 2. The slide
 3. The launch actuator reset assembly
 4. The buffer cylinder
- 4-13. During NGL operation, when the slide assembly is forward, what device holds the reset-assembly slider above the surface of the guide track deck housing cavity?
1. The slider actuating spring
 2. The actuator assembly
 3. The buffer hook
 4. The shuttle spreader
- 4-14. Which of the following statements best describes the NGL shock absorber assembly?
1. A self-contained, sealed unit that requires no maintenance or adjustments
 2. A hydraulically operated, three-cylinder, buffer unit
 3. A hydraulically operated buffer unit that uses tube orifices to meter fluid flow
 4. A piston-type accumulator energy absorber
- 4-15. What device controls the flow of hydraulic fluid supplied from the catapult hydraulic system to the NGL buffer cylinder?
1. The NGL dump valves
 2. The NGL pilot valve
 3. The NGL valve manifold
 4. The NGL buffer cylinder control valve
- 4-16. ALRE maintenance functions are divided into what total number of maintenance levels?
1. One
 2. Two
 3. Three #
 4. Four
- 4-17. Maintenance tasks are assigned according to the complexity, scope, and range of the work to be performed.
1. True
 2. False
- 4-18. Which of the following is NOT a function of organizational maintenance?
1. Inspection, operation, and servicing as defined and required by PMS
 2. Corrective and preventive maintenance
 3. Record keeping and report writing
 4. Type III calibration of designated equipment
- 4-19. What maintenance activity performs type III calibration?
1. Organizational maintenance
 2. Intermediate maintenance
 3. Depot maintenance
 4. Navy ASO
- 4-20. What type of maintenance is normally accomplished by the catapult and arresting gear crew members?
1. Upkeep
 2. Overhaul
 3. Intermediate maintenance
 4. Depot maintenance
- 4-21. In the V-2 maintenance organization, who has the authority to certify that maintenance actions have been completed and that the equipment can be returned to an operational status?
1. The division officer or maintenance officer
 2. The catapult officer or recovery officer
 3. The maintenance officer or maintenance control chief
 4. The maintenance officer only
- 4-22. Which of the following personnel are responsible for the day-to-day operations of the work center, the nomination of qualified personnel to be collateral duty inspectors, and the assignment of work center personnel to specific maintenance tasks?
1. The maintenance officer, work center group supervisors, and work center supervisors
 2. Work center group supervisors and work center supervisors only
 3. Work center group supervisors, the QA work center supervisor, and the maintenance support work center supervisor
 4. The maintenance officer, the maintenance control chief, and work center group supervisors

- 4-23. Which of the following VIDs boards provides information pertaining to the divisions's overall maintenance status?
1. The maintenance support work center board
 2. The Quality Assurance work center board
 3. The maintenance control work center board
 4. The material control work center board
- 4-24. A total of how many information display columns are required on both the maintenance control and all other work center VIDs boards?
1. Seven
 2. Six
 3. Five
 4. Four
- 4-25. What color is used to indicate limited capability on the Maintenance Action Form (MAF) cards?
1. Blue
 2. Red
 3. Black
 4. Yellow
- 4-26. On the MAF card, what color is used to indicate the equipment is out of commission?
1. Yellow
 2. Red
 3. Black
 4. Blue
- 4-27. The priority section of the MAF card can be color coded to indicate the maintenance status and operational capability of specific equipment. What status is indicated if no color code is used in the priority section?
1. The equipment is out of commission
 2. The equipment may be used, but has only limited capability
 3. The maintenance is routine and does not affect equipment capability
 4. The maintenance has been completed and the equipment only needs a functional check to be returned to full operational capability
- 4-28. On the MAF card, what color is used for a completed maintenance action awaiting a functional check?
1. Blue
 2. Red
 3. Black
 4. Yellow
- 4-29. What copy, if any, of the completed ALRE MAF is retained by the maintenance responsible work center?
1. One
 2. Two
 3. Three
 4. None
- 4-30. Who is responsible for updating and maintaining the work center maintenance requirement status board?
1. The maintenance control chief
 2. The work center group supervisor
 3. The maintenance control officer
 4. The work center supervisor
- 4-31. What is the primary role of the V-2 maintenance support branch?
1. To manage the division tool control program
 2. To provide technical expertise to operating work centers
 3. To reduce man-hours required to complete maintenance tasks
 4. To manage the division man-hour accounting program
- 4-32. When the Maintenance Support (MS) branch assigns personnel to assist in maintenance performed by the operating work center, who documents the MS man-hours?
1. Maintenance Control
 2. Maintenance Support
 3. The QA branch
 4. The operating work center
- 4-33. The tool control program was established to reduce the potential of tool-related foreign object damage and to reduce the cost of tool replacement.
1. True
 2. False

- 4-34. Which of the following is NOT a benefit of the tool control program?
1. Reduced tool replacement costs
 2. Reduced equipment failures
 3. Reduced tool pilferage
 4. Assurance of tool availability to perform maintenance
- 4-35. Detailed information concerning the ALRE TCP can be found in what publication?
1. NAEC Miscellaneous Report 51/OR732
 2. NAEC Report No. CD-1025
 3. NAVAIR 80R-14
 4. OPNAVINST 4790.4B
- 4-36. The achievement of a properly functioning quality assurance program exhibits which of the following characteristics?
1. The program is managed by the maintenance control officer, maintenance control chief, and work center group supervisors
 2. Eliminates unnecessary man-hour and dollar expenses
 3. Uses prevention, knowledge, and special skills
 4. Stresses the gathering and maintaining of information on quality assurance
- 4-37. What is the basis of maintenance and operational decisions through the Quality Assurance (QA) program?
1. Memory
 2. Intuition
 3. Factual data
 4. The maintenance officer's experience
- 4-38. When it becomes necessary to augment the quality assurance branch with CDQAIs, they must be designated in writing by which of the following officers?
1. The commanding officer
 2. The air department officer
 3. The V-2 division officer
 4. The V-2 maintenance officer
- 4-39. When it is necessary to augment the QA branch with Collateral Duty QA inspectors (CDQAIs) below the paygrade of E-6 for more than 90 days, who must approve the continued augmentation?
1. The maintenance officer
 2. The division officer
 3. The commanding officer
 4. The type commander
- 4-40. Who is most directly concerned with, and responsible for, quality in workmanship?
1. The maintenance officer
 2. The assigned quality assurance inspector
 3. The work center supervisor
 4. The equipment operator
- 4-41. Which of the following duties is NOT a responsibility of the quality assurance branch?
1. To prepare maintenance instructions
 2. To provide technical assistance to collateral duty inspectors
 3. To manage the dispersed technical publications libraries
 4. To develop audit checklists
- 4-42. CDIs are designated in writing by which of the following officers?
1. The air department officer
 2. The executive officer
 3. The commanding officer
 4. The maintenance officer
- 4-43. How often are work center audits conducted?
1. Weekly
 2. Monthly
 3. Quarterly
 4. Semi-annually
- 4-44. What type of audit is conducted to evaluate a specific maintenance task?
1. Work center audit
 2. Special audit
 3. Internal audit
 4. Type commander audit

4-45. The quality assurance branch uses special audits for which of the following reasons?

1. To evaluate the overall quality of performance of each work center
2. To evaluate tool control program compliance
3. To monitor programs specifically assigned to the QA branch for monitoring
4. To establish follow-up procedures to ensure that previous audit discrepancies have been corrected

(THIS PAGE IS INTENTIONALLY LEFT BLANK.)

ASSIGNMENT 5

Textbook Assignment: "Maintenance Planning and Administration," Pages 7-1 through 7-47.

- 5-1. What factors must be considered in the planning and scheduling of maintenance?
1. Operational requirements
 2. Available personnel
 3. Equipment status
 4. All of the above
- 5-2. Which of the following statements best defines preventive maintenance?
1. Any action that maintains equipment warranties
 2. Any action that maintains equipment in operating condition
 3. Any action that is entered in the rough work log
 4. Any action taken in addition to normal workload
- 5-3. Which of the following sources provides a listing of the MIPs assigned to each department?
1. Workcenter PMS Manual
 2. Divisional LOEP
 3. Departmental LOEP
 4. Ship's cycle schedule
- 5-4. Which of the following sources contains detailed procedures used to perform a maintenance action?
1. MIP
 2. LOEP
 3. MRC
 4. PMS Manual
- 5-5. What does the second part of the MRC code represent?
1. Periodicity code
 2. MIP series code
 3. Ship's system code
 4. Equipment code
- 5-6. An R-1W is an example of what type of periodicity code?
1. Calendar-situation
 2. Situation-calendar
 3. Situation
 4. Calendar
- 5-7. Entries made in the TOOLS, PARTS, MATERIALS, TEST EQUIPMENT block of an MRC can be cross-referenced to the SPMIG for stock number identification.
1. True
 2. False
- 5-8. What information determines the number of items to be listed on an Equipment Guide List?
1. Skill level of the maintenance person
 2. Time allotted to perform maintenance on each item
 3. Number of days required to complete entire maintenance action
 4. All of the above
- 5-9. Who must approve a request to combine the PMS maintenance requirements of two or more workcenters?
1. Type commander
 2. Commanding officer
 3. Department head
 4. Division officer
- 5-10. Preparation of a PMS Cycle Schedule requires use of all EXCEPT which of the following?
1. Applicable MRCs
 2. Blank cycle schedules
 3. Previous quarterly schedule
 4. Master PMS Manual
- 5-11. Which of the following schedules is NOT a PMS schedule?
1. Cycle
 2. Quarterly
 3. Monthly
 4. Weekly
- 5-12. How are mandatory related maintenance checks indicated on the Cycle Schedule?
1. They are circled in red
 2. They are circled in blue
 3. A star sign
 4. A pound sign

- 5-13. Which of the following information is NOT found on the quarterly PMS schedule?
1. Workcenter code
 2. Maintenance person's name
 3. Quarter after overhaul
 4. Department head's signature
- 5-14. How many columns are available on the quarterly schedule for the scheduling of weekly maintenance?
1. 13
 2. 16
 3. 20
 4. 24
- 5-15. When a ship's major overhaul is completed during the last two weeks of May, what months are included on the first quarterly schedule after overhaul?
1. April, May, and June
 2. May, June, and July
 3. June, July, and August
 4. The first full fiscal quarter after overhaul
- 5-16. When the quarterly PMS schedule is prepared, how are the ship's underway periods indicated?
1. By writing "underway" on the schedule during these periods
 2. By shading in the periods on the bottom line of the schedule
 3. By shading in the tick marks indicating the days of the quarter at the top of the schedule
 4. By shading in the tick marks indicating the days of the quarter at the bottom of the schedule
- 5-17. Any maintenance requirement that cannot be completed within its periodicity during a quarter must be circled on the front of the quarterly schedule only to explain that it was not completed.
1. True
 2. False
- 5-18. What PMS schedule is used by the workcenter supervisor to assign and monitor PMS accomplishments?
1. Cycle
 2. Quarterly
 3. Weekly
 4. Daily
- 5-19. Which of the following provides information needed for workload planning and a means of evaluating and improving fleet installed equipment?
1. Maintenance Data System
 2. Planned Maintenance System
 3. Failed Parts Reporting System
 4. Configuration Accounting System
- 5-20. Under MDS, Individual maintenance actions are identified by what number?
1. Maintenance Action Number
 2. Job Control Number
 3. Job Sequence Number
 4. Job Serial Number
- 5-21. How is an error corrected when entries are made on an OPNAV 4790/2K form?
1. "X" out the error and continue
 2. Make out a new OPNAV 4790/2K
 3. Draw a single line through the error and continue
 4. Put white on the error and continue
- 5-22. What information is normally found in section V of an OPNAV 4790/2K forms?
1. Repair activity planning
 2. Equipment location
 3. Availability of blueprints
 4. Reason for deferring maintenance
- 5-23. Which of the following forms is used to report a ship's configuration change?
1. OPNAV 4790/2K
 2. OPNAV 4790/2P
 3. OPNAV 4790/2Q
 4. OPNAV 4790/CK
- 5-24. What two-character code identifies the inventory manager and the stores account?
1. The Purpose code
 2. The Special Material Identification code
 3. The Cognizance Symbol code
 4. The Fund code
- 5-25. What character of a cognizance symbol identifies the stores account?
1. First
 2. Second
 3. Third
 4. Fourth

- 5-26. Which of the following cognizance symbols identifies APA material?
1. 1R
 2. 3H
 3. 5R
 4. 6R
- 5-27. Which of the following cognizance symbols identifies NSA material?
1. 1R
 2. 4R
 3. 6R
 4. 8R
- 5-28. What activity manages the Federal Cataloging System within the DOD?
1. DLA
 2. DLSC
 3. ASO
 4. GSA
- 5-29. The first two digits of an FSC identifies which of the following items?
1. The single item, component, or equipment
 2. The major division of commodities within a group
 3. The commodities according to physical or performance characteristics
 4. The group/category inventory managers
- 5-30. What FSC groups are used by the Navy for forms and publications?
1. 90 through 99
 2. 70 through 80
 3. 30 through 40
 4. 01 through 09
- 5-31. Which of the following FSC groups is NOT included in the Federal Cataloging System?
1. 08
 2. 28
 3. 48
 4. 58
- 5-32. An NSN has what total number of digits?
1. 7
 2. 9
 3. 13
 4. 15
- 5-33. What activity is responsible for assigning the NSN to material for supply department stock?
1. The Defense Logistics Agency
 2. The Supply Department
 3. The Naval Supply Center
 4. The Defense Logistics Support Center
- 5-34. Which of the following NSNs was assigned by the U.S.?
1. 1234-21-012-3456
 2. 1234-11-001-2345
 3. 1234-01-234-5678
 4. 1234-13-234-6543
- 5-35. To properly identify material, you should know what number of digits of the NIIN?
1. The first four
 2. The first seven
 3. The last seven
 4. The last nine
- 5-36. What account is paid the required use what for out of appropriations and is NOT chargeable to the user's operating funds?
1. APA
 2. NSA
 3. TFA
 4. OPTAR
- 5-37. Which of the following items are the same as NSA items?
1. APA items
 2. Repairable items
 3. Expense type items
 4. Remain-in-place items
- 5-38. The forms and publications used by the Navy are under the inventory control of what activity?
1. NPFD
 2. SPCC
 3. NAVAIR
 4. ASO
- 5-39. The technical responsibility for aircraft engines in the Navy belongs to what activity?
1. NAVAIR
 2. SPCC
 3. ASO
 4. NPPS

- 5-40. Aviation depot-level repairable material is assigned what cognizance symbol?
1. 1R
 2. 4R
 3. 5R
 4. 7R
- 5-41. What activity is the cognizant item manager for 7R material?
1. NAVICP PHIL
 2. NAVAIR
 3. NAVFAC
 4. ASO
- 5-42. The cataloging code assigned to defense electronic material is equivalent to what cognizance symbol of Navy material?
1. 9C
 2. 9D
 3. 9G
 4. 9N
- 5-43. The Material Control code is assigned by what person?
1. The executive officer
 2. The inventory manager
 3. The technical advisor for the material
 4. The commanding officer
- 5-44. What Material Control code is assigned to an item that is field-level repairable?
1. D
 2. E
 3. H
 4. L
- 5-45. Depot-level repairable is assigned what Material Control code?
1. D
 2. H
 3. L
 4. M
- 5-46. What Material Control code is assigned to an end item of ground support equipment?
1. E
 2. H
 3. S
 4. W
- 5-47. What does NICN stand for?
1. National Item Control Number
 2. Navy Item Control Number
 3. Navy Integrated Control Number
 4. Navy Item Consolidation Number
- 5-48. Which of the following items are identified by NICNs?
1. Kit numbers
 2. Publications and forms
 3. NAC numbers
 4. All of the above
- 5-49. In a 13-digit NICN, what code occupies the 5th and 6th positions?
1. The Navy Item Control Number code
 2. The Material Control code
 3. The Supply Classification code
 4. The Special Material Identification code
- 5-50. Which of the following NIC codes identifies a form?
1. LD
 2. LK
 3. LP
 4. LF
- 5-51. What type of material is identified in NICN 1234-LK-123-4567?
1. A directive
 2. A form
 3. An aircraft change kit
 4. A publication
- 5-52. Locally assigned item control numbers contain what letters in the 5th and 6th positions?
1. LF
 2. LL
 3. LQ
 4. LX
- 5-53. What format is used to order material identified by a NICN?
1. The DD 1348 format
 2. The DD 1348-6 format
 3. The DD 1384 format
 4. The DD 1387 format

- 5-54. A temporary NICN is assigned to material for which of the following purposes?
1. To identify the items before the assignment of an NSN
 2. To control the items pending an NSN assignment
 3. Both 1 and 2 above
 4. To release the shipment from the manufacturer
- 5-55. What activity is responsible for maintaining the NICN to NSN cross-reference list?
1. ASO
 2. DLIS
 3. SPCC
 4. NALC
- 5-56. The cumulative listing of National Stock Numbers for all armed services is identified by which of the following letters?
1. ML-N
 2. ML-C
 3. MRC
 4. MDC
- 5-57. Which of the following lists provides cross-reference information from reference numbers to NSNs?
1. ML-N
 2. ML-C
 3. MCRL
 4. MRIL
- 5-58. What cognizance symbol is assigned to items listed in the GSA Federal Supply Catalog?
1. 9C
 2. 9D
 3. 9N
 4. 9Q
- 5-59. Which of the following lists is a catalog of Navy-managed repairable items and provides shipping information for unserviceable components?
1. ML-C
 2. ML-N
 3. MRIL
 4. MCRL
- 5-60. Why is the arresting gear maintenance log considered the most important record kept on the arresting gear equipment?
1. It contains recovery log information
 2. It contains the names of maintenance personnel
 3. It contains wire rope history report information
 4. It contains most of the information needed to complete other reports and records

