



**NONRESIDENT
TRAINING
COURSE**



July 2002

Aviation Structural Mechanic (AM)

NAVEDTRA 14315

DISTRIBUTION STATEMENT A: Approved for public release; distribution is unlimited.

Although the words “he,” “him,” and “his” are used sparingly in this course to enhance communication, they are not intended to be gender driven or to affront or discriminate against anyone.

DISTRIBUTION STATEMENT A: Approved for public release; distribution is unlimited.

PREFACE

By enrolling in this self-study course, you have demonstrated a desire to improve yourself and the Navy. Remember, however, this self-study course is only one part of the total Navy training program. Practical experience, schools, selected reading, and your desire to succeed are also necessary to successfully round out a fully meaningful training program.

THE COURSE: This self-study course is organized into subject matter areas, each containing learning objectives to help you determine what you should learn along with text and illustrations to help you understand the information. The subject matter reflects day-to-day requirements and experiences of personnel in the rating or skill area. It also reflects guidance provided by Enlisted Community Managers (ECMs) and other senior personnel, technical references, instructions, etc., and either the occupational or naval standards, which are listed in the *Manual of Navy Enlisted Manpower Personnel Classifications and Occupational Standards*, NAVPERS 18068.

THE QUESTIONS: The questions that appear in this course are designed to help you understand the material in the text.

VALUE: In completing this course, you will improve your military and professional knowledge. Importantly, it can also help you study for the Navy-wide advancement in rate examination. If you are studying and discover a reference in the text to another publication for further information, look it up.

*2002 Edition Prepared by
AMC(AW) Paul Breidenbaugh
AMC(AW) Kevin Castillo
AMC(AW/NAC) Archie Manning*

Published by
NAVAL EDUCATION AND TRAINING
PROFESSIONAL DEVELOPMENT
AND TECHNOLOGY CENTER

**NAVSUP Logistics Tracking Number
0504-LP-100-1145**

Sailor's Creed

"I am a United States Sailor.

I will support and defend the Constitution of the United States of America and I will obey the orders of those appointed over me.

I represent the fighting spirit of the Navy and those who have gone before me to defend freedom and democracy around the world.

I proudly serve my country's Navy combat team with honor, courage and commitment.

I am committed to excellence and the fair treatment of all."

TABLE OF CONTENTS

CHAPTER	PAGE
1. General Aircraft Maintenance.....	1-1
2. Aircraft Construction and Materials	2-1
3. Aircraft Hardware	3-1
4. Aircraft Metallic Repair.....	4-1
5. Aircraft Nonmetallic Repair	5-1
6. Nondestructive Inspections, Welding, and Heat Treatment.....	6-1
7. Aircraft Wheels, Tires, and Tubes	7-1
8. Basic Hydraulics	8-1
9. Fluid Servicing and Support Equipment.....	9-1
10. Hose and Tubing Fabrication and Maintenance	10-1
11. Basic Actuating Systems.....	11-1
12. Basic Hydraulic/Pneumatic and Emergency Power Systems	12-1
13. Landing Gear Systems	13-1
14. Brake Systems.....	14-1
15. Utility Hydraulic Systems.....	15-1
16. Fixed-Wing Flight Control Systems	16-1
17. Rotary-Wing Flight Control Systems	17-1
APPENDIX	
I. Glossary	AI-1
II. References Used to Develop the Nonresident Training Course.....	AII-1
III. Answers to Review Questions.....	AIII-1

ASSIGNMENT QUESTIONS follow Appendix III.

INSTRUCTIONS FOR TAKING THE COURSE

ASSIGNMENTS

The text pages that you are to study are listed at the beginning of each assignment. Study these pages carefully before attempting to answer the questions. Pay close attention to tables and illustrations and read the learning objectives. The learning objectives state what you should be able to do after studying the material. Answering the questions correctly helps you accomplish the objectives.

SELECTING YOUR ANSWERS

Read each question carefully, then select the BEST answer. You may refer freely to the text. The answers must be the result of your own work and decisions. You are prohibited from referring to or copying the answers of others and from giving answers to anyone else taking the course.

SUBMITTING YOUR ASSIGNMENTS

To have your assignments graded, you must be enrolled in the course with the Nonresident Training Course Administration Branch at the Naval Education and Training Professional Development and Technology Center (NETPDTC). Following enrollment, there are two ways of having your assignments graded: (1) use the Internet to submit your assignments as you complete them, or (2) send all the assignments at one time by mail to NETPDTC.

Grading on the Internet: Advantages to Internet grading are:

- you may submit your answers as soon as you complete an assignment, and
- you get your results faster; usually by the next working day (approximately 24 hours).

In addition to receiving grade results for each assignment, you will receive course completion confirmation once you have completed all the

assignments. To submit your assignment answers via the Internet, go to:

<http://courses.cnet.navy.mil>

Grading by Mail: When you submit answer sheets by mail, send all of your assignments at one time. Do NOT submit individual answer sheets for grading. Mail all of your assignments in an envelope, which you either provide yourself or obtain from your nearest Educational Services Officer (ESO). Submit answer sheets to:

COMMANDING OFFICER
NETPDTC N331
6490 SAUFLEY FIELD ROAD
PENSACOLA FL 32559-5000

Answer Sheets: All courses include one "scannable" answer sheet for each assignment. These answer sheets are preprinted with your SSN, name, assignment number, and course number. Explanations for completing the answer sheets are on the answer sheet.

Do not use answer sheet reproductions: Use only the original answer sheets that we provide—reproductions will not work with our scanning equipment and cannot be processed.

Follow the instructions for marking your answers on the answer sheet. Be sure that blocks 1, 2, and 3 are filled in correctly. This information is necessary for your course to be properly processed and for you to receive credit for your work.

COMPLETION TIME

Courses must be completed within 12 months from the date of enrollment. This includes time required to resubmit failed assignments.

PASS/FAIL ASSIGNMENT PROCEDURES

If your overall course score is 3.2 or higher, you will pass the course and will not be required to resubmit assignments. Once your assignments have been graded you will receive course completion confirmation.

If you receive less than a 3.2 on any assignment and your overall course score is below 3.2, you will be given the opportunity to resubmit failed assignments. **You may resubmit failed assignments only once.** Internet students will receive notification when they have failed an assignment—they may then resubmit failed assignments on the web site. Internet students may view and print results for failed assignments from the web site. Students who submit by mail will receive a failing result letter and a new answer sheet for resubmission of each failed assignment.

COMPLETION CONFIRMATION

After successfully completing this course, you will receive a letter of completion.

ERRATA

Errata are used to correct minor errors or delete obsolete information in a course. Errata may also be used to provide instructions to the student. If a course has an errata, it will be included as the first page(s) after the front cover. Errata for all courses can be accessed and viewed/downloaded at:

<http://www.advancement.cnet.navy.mil>

STUDENT FEEDBACK QUESTIONS

We value your suggestions, questions, and criticisms on our courses. If you would like to communicate with us regarding this course, we encourage you, if possible, to use e-mail. If you write or fax, please use a copy of the Student Comment form that follows this page.

For subject matter questions:

E-mail: n315.products@cnet.navy.mil
Phone: Comm: (850) 452-1001, ext. 1714
DSN: 922-1001, ext. 1714
FAX: (850) 452-1370
(Do not fax answer sheets.)
Address: COMMANDING OFFICER
NETPDTC (CODE N315)
6490 SAUFLEY FIELD ROAD
PENSACOLA FL 32509-5237

For enrollment, shipping, grading, or completion letter questions

E-mail: fleetservices@cnet.navy.mil
Phone: Toll Free: 877-264-8583
Comm: (850) 452-1511/1181/1859
DSN: 922-1511/1181/1859
FAX: (850) 452-1370
(Do not fax answer sheets.)
Address: COMMANDING OFFICER
NETPDTC N331
6490 SAUFLEY FIELD ROAD
PENSACOLA FL 32559-5000

NAVAL RESERVE RETIREMENT CREDIT

If you are a member of the Naval Reserve, you may earn retirement points for successfully completing this course, if authorized under current directives governing retirement of Naval Reserve personnel. For Naval Reserve retirement, this course is evaluated at 20 points. These points will be credited as follows:

12 points for the satisfactory completion of assignments 1 through 8.

8 points for the satisfactory completion of assignments 9 through 13.

(Refer to *Administrative Procedures for Naval Reservists on Inactive Duty*, BUPERSINST 1001.39, for more information about retirement points.)

CREDITS

The following are trademarks used in this Nonresident Training Course.

Teflon® and Kevlar® are registered trademarks of E.I. DuPont DeNemours and Company. Teflon® is DuPont's registered trademark for its fluorocarbon resin. Kevlar® is DuPont's registered trademark for its structural grade fiber.

Student Comments

Course Title: Aviation Structural Mechanic

NAVEDTRA: 14315 Date: _____

We need some information about you:

Rate/Rank and Name: _____ SSN: _____ Command/Unit _____

Street Address: _____ City: _____ State/FPO: _____ Zip _____

Your comments, suggestions, etc.:

Privacy Act Statement: Under authority of Title 5, USC 301, information regarding your military status is requested in processing your comments and in preparing a reply. This information will not be divulged without written authorization to anyone other than those within DOD for official use in determining performance.

NETPDTC 1550/41 (Rev 4-00)

CHAPTER 1

GENERAL AIRCRAFT MAINTENANCE

INTRODUCTION

This chapter discusses the various types of routine aircraft maintenance performed by the AM ratings. When performing any type of maintenance, it is your responsibility to comply with all safety procedures and tool control requirements. Because no one set of rules applies to all aircraft, you should refer to the maintenance instruction manual (MIM) for the tools, materials, and procedures required for that particular aircraft or piece of equipment.

TOOL CONTROL PROGRAM

LEARNING OBJECTIVE: Recognize the importance of the Navy's Tool Control Program (TCP).

Major problems, such as aircraft accidents and incidents, may result from tools left in an aircraft after maintenance has been performed. Tools out of place may result in foreign object damage (FOD). To reduce the potential for tool FOD-related mishaps, the Tool Control Program (TCP) provides a means of rapidly accounting for all tools after completing a maintenance task on an aircraft or its related equipment.

TOOL CONTAINERS

The means by which tools can be rapidly inventoried and accounted for is accomplished by using silhouetted tool containers. All tools have individual silhouetted locations that highlight a missing tool. These containers are called "shadow boxes." A shadow (silhouette) of the tool identifies the place where the tool belongs. The TCP is based on the instant inventory concept and is accomplished, in part, through the use of shadow boxes. See figure 1-1. On containers where silhouetting is not feasible, a note with the inventory and a drawing of the container is included. Either system enables the work center supervisor or inspector to quickly ensure that all tools have been retrieved after a maintenance action.

The material control officer is responsible for coordinating the TCP and for ensuring that tools are procured and issued in a controlled manner consistent with the approved tool control plan (TCPL). A TCPL

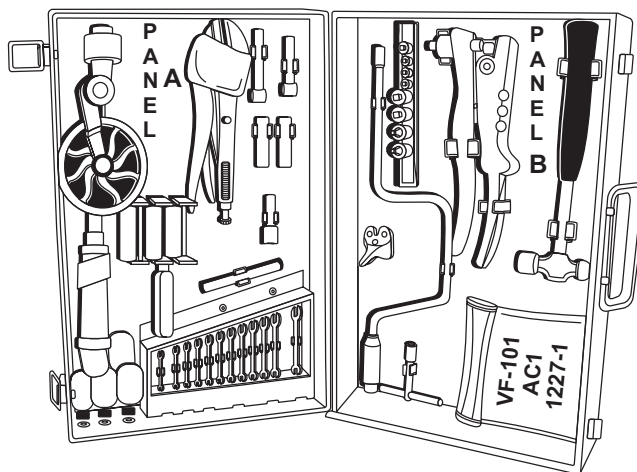

AM01001

Figure 1-1.—Typical silhouette toolbox.

contains information that includes material requirements, tool inventories, and detailed instructions for the implementation and operation of the TCPL for a specific type/model of aircraft. But the main responsibility relies with the work center and quality assurance.

QUALITY ASSURANCE/ANALYSIS (QA/A) RESPONSIBILITIES

The QA/A division is responsible for monitoring the overall Tool Control Program in the command. While monitoring the program or performing "spot checks," the QA/A division will ensure that tool control procedures are being adhered to. Some of the special requirements are to ensure the following:

1. That all tools are etched with the organization code, work center, and tool container number.
2. That special accountability procedures are being complied with for those tools not suitable for etching; for example, drill bits (too hard) and jewelers screwdrivers (too small).
3. That work center inventories are being conducted and procedures are being adhered to during work center audits and periodic spot checks.

4. That all equipment, in the work centers or tool control centers, that require calibration is scheduled and calibrated at the prescribed interval.

5. That defective tools received from supply are reported to the Fleet Material Support Office (FLEMATSUPPO) via CAT II Quality Deficiency Reports (QDRs).

6. That tools of poor quality are reported to FLEMATSUPPO via CAT II QDRs.

7. That VIDS/MAFs are annotated with a tool container number, and appropriate initials are obtained following task completion/work stoppage.

8. That the department's tool control environment is maintained when work is to be performed by contractor maintenance teams or depot field teams. A QAR will brief field team/contractor supervisor/leader(s) upon their arrival regarding the activity's TCP. Depot teams working in O- or I-level facilities will comply with the host activity's TCP.

WORK CENTER RESPONSIBILITIES

All work center supervisors have specific responsibilities under the TCP. All tool containers should have a lock and key as part of their inventory. The supervisor should be aware of the location of each container's keys and have a way of controlling them. When work is to be completed away from the workspaces (for example, the flight line/flight deck), complete tool containers, not a handful of tools, should be taken to the job. If more tools are needed than the tool container contains, tool tags can be used to check out tools from other tool containers in the work center or from another work center. The following is a list of additional responsibilities of the work center supervisor:

1. Upon task assignment, note the number of the tool container on copy 1 of the VIDS/MAF, left of the accumulated work hours section. A sight inventory will be conducted by the technician prior to commencement of each task, and all shortages will be noted. Every measure must be taken to ensure that missing tools do not become a cause of FOD. Inventories will also be performed before a shift change, when work stoppage occurs, after maintenance has been completed, and before conducting an operational systems check on the equipment.

2. When all tools are accounted for and all maintenance actions have been completed, the work center supervisor signs the VIDS/MAF, signifying that

maintenance has been completed and that all tools have been accounted for.

3. If any tool is found to be missing during the required inventories, conduct an immediate search prior to reporting the work completed or signing off the VIDS/MAF. If the tool cannot be located, notify the maintenance officer or assistant maintenance officer via the work center supervisor and maintenance control to ensure that the aircraft or equipment is not released.

If the tool cannot be located after the maintenance officer's directed search, the person doing the investigation will personally sign a statement in the Corrective Action block of the VIDS/MAF that a lost tool investigation was conducted and that the tool could not be found. Subsequently, the normal VIDS/MAF completion process will be followed.

The flight engineer/crew chief (senior maintenance man in the absence of an assigned crew chief) will assume the responsibilities of the work center supervisor applicable to the TCP in the event of in-flight maintenance or maintenance performed on the aircraft at other than home station.

Q1-1. The tool control program is based on what inventory concept?

Q1-2. What officer is responsible for coordinating the tool control program?

Q1-3. What division is responsible for monitoring the tool control program?

Q1-4. Tools of poor quality are reported to what office?

Q1-5. Who has the overall responsibility for control of all tool containers and their keys?

Q1-6. What officer must be notified that a missing tool cannot be found?

OCCUPATIONAL AWARENESS

LEARNING OBJECTIVE: Identify sources of information regarding hazards within the AM rating. Recognize terms applicable to hazardous situations and materials.

Many different materials are used in the workplace. Some are hazardous. You must know where to retrieve information on these materials used in and around naval aircraft. The MIMs give information on correct maintenance practices, but may not always give complete information regarding necessary safety practices.

The Navy Occupational Safety and Health (NAVOSH) program was established to inform workers about hazards and the measures necessary to control them. The Department of Defense has established the Hazardous Material Information System (HMIS), which is designed to acquire, store, and disseminate

data on hazardous material procured for use. The primary source for you to get the necessary information before beginning any operation involving the use of hazardous material is the Material Safety Data Sheet (MSDS). The MSDS, known as Form OSHA-20, is shown in figure 1-2. This nine-section form informs

U.S. DEPARTMENT OF LABOR Occupational Safety and Health Administration		Form Approved OMB No. 44-R 1387	
MATERIAL SAFETY DATA SHEET			
Required under USDL Safety and Health Regulations for Ship Repairing, Shipbuilding, and Shipbreaking (29 CFR 1915, 1916, 1917)			
SECTION 1			
MANUFACTURER'S NAME		EMERGENCY TELEPHONE NO.	
ADDRESS (Number, Street, City, State, and ZIP Code)			
CHEMICAL NAME AND SYNONYMS		TRADE NAME AND SYNONYMS	
CHEMICAL FAMILY		FORMULA	
SECTION II - HAZARDOUS INGREDIENTS			
PAINTS, PRESERVATIVES & SOLVENTS	%	TLV (Units)	ALLOYS AND METALLIC COATINGS
PIGMENTS			BASE METAL
CATALYST			ALLOYS
VEHICLE			METALLIC COATINGS
SOLVENTS			FILLER METAL PLUS COATING OR CORE FLUX
ADDITIVES			OTHERS
OTHERS			
HAZARDOUS MIXTURES OF OTHER LIQUIDS, SOLIDS, OR GASES			% TLV (Units)
SECTION III - PHYSICAL DATA			
BOILING POINT (°F.)		SPECIFIC GRAVITY (H20 = 1)	
VAPOR PRESSURE (mm Hg.)		PERCENT, VOLATILE BY VOLUME (%)	
VAPOR DENSITY (AIR = 1)		EVAPORATION RATE (----- = 1)	
SOLUBILITY IN WATER			
APPEARANCE AND ODOR			
SECTION IV - FIRE AND EXPLOSION HAZARD DATA			
FLASH POINT (Method used)	FLAMMABLE LIMITS	Le1	Ue1
EXTINGUISHING MEDIA			
SPECIAL FIRE FIGHTING PROCEDURES			
UNUSUAL FIRE AND EXPLOSION HAZARDS			
PAGE (1)		(Continued on reverse side)	
		Form OSHA - 20 Rev. May 72	

AM#1002(A)

Figure 1-2.—Material safety data sheet (page 1).

SECTION V - HEALTH HAZARD DATA			
THRESHOLD LIMIT VALUE			
EFFECTS OF OVEREXPOSURE			
EMERGENCY AND FIRST AID PROCEDURES			
SECTION VI - REACTIVITY DATA			
STABILITY	UNSTABLE		CONDITIONS TO AVOID
	STABLE		
INCOMPATIBILITY (Materials to avoid)			
HAZARDOUS DECOMPOSITION PRODUCTS			
HAZARDOUS POLYMERIZATION	MAY OCCUR		CONDITIONS TO AVOID
	WILL NOT OCCUR		
SECTION VII - SPILL OR LEAK PROCEDURES			
STEPS TO BE TAKEN IN CASE MATERIAL IS RELEASED OR SPILLED			
WASTE DISPOSAL METHOD			
SECTION VIII - SPECIAL PROTECTION INFORMATION			
RESPIRATORY PROTECTION (SPECIFY TYPE)			
VENTILATION	LOCAL EXHAUST		SPECIAL
	MECHANICAL (General)		OTHER
PROTECTIVE GLOVES		EYE PROTECTION	
OTHER PROTECTIVE EQUIPMENT			
SECTION IX-SPECIAL PRECAUTIONS			
PRECAUTIONS TO BE TAKEN IN HANDLING AND STORING			
OTHER PRECAUTIONS			

PAGE (2)

GPO 904 - 110

FORM OSHA - 20
Rev. May 72

AMF01002(B)

Figure 1-2.—Material safety data sheet (page 2)—Continued.

you of hazards involved, symptoms of exposure, protective measures required, and procedures to be followed in case of spills, fire, overexposure, or other emergency situations.

The maintenance of safe and healthful working conditions is a chain-of-command responsibility. Implementation begins with the individual sailor and extends to the commanding officer. The

chain-of-command responsibilities are covered in OPNAVINST 5100.19 (series) and OPNAVINST 5100.23 (series).

Work center supervisors are responsible for training work center personnel in the use of the MSDS. Furthermore, they must ensure that personnel under their supervision are trained on the hazards associated with the material and are equipped with the proper protective equipment before using any hazardous materials.

All sections of the MSDS form are important, and contain information to accomplish a task without causing damage to equipment or personnel. Always ensure that you are using the correct MSDS with the material being used. You should check the MILSPEC, part number, federal stock number, and the name of the manufacturer. Never use the MSDS with different manufacturers. The formula for a given product may differ and still meet the specification requirements. The handling and safety requirements will effectively change based on different manufacturers.

Threshold Limit Value (TLV) in sections II and V of the MSDS are established by the American Conference of Governmental Industrial Hygienists (CGIH). TLVs refer to airborne concentrations of a substance and represent conditions that nearly all workers may be exposed, day after day, without adverse effects. You should know the effects of overexposure and the emergency procedures required before using any material.

Section VI (Reactivity Data) of the MSDS contains a list of materials and conditions to avoid that could cause special hazards. Prompt cleanup of spills and leaks will lessen the chance of harm to personnel and the environment. Section VII (Spill or Leak Procedures) of the MSDS lists the required steps to be taken for cleanup and proper disposal methods.

You should be familiar with section VIII (Special Protective Information) of the MSDS. In doing so, you will protect yourself and others from dangerous exposure. Some protective equipment is complex and requires special training in proper use and care. Never use a respirator that you have not fit-tested to wear. Always check to see that the cartridge installed meets the requirements of the MSDS. If you use a respirator you have not been trained for or fitted to, or with the wrong cartridge installed, it can be as dangerous to your health as wearing no protection at all.

You need to be aware of word usage and intended meaning as pertains to hazardous equipment and/or

conditions. These terms are used in most technical manuals prepared for the Navy.

The following is a list of safety hazard words and definitions as they appear in most naval aviation technical manuals.

WARNING

An operating procedure, practice, or condition, etc., that may result in injury or death if not carefully observed or followed.

CAUTION

An operating procedure, practice, or condition, etc., that may result in damage or destruction to equipment if not carefully observed or followed.

NOTE

An operating procedure, practice, or condition, etc., that is essential to emphasize.

SHALL has been used only when application of a procedure is mandatory.

SHOULD has been used only when application of a procedure is recommended.

MAY and **NEED NOT** have been used only when application of a procedure is optional.











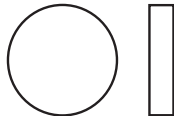

WILL has been used only to indicate futurity, never to indicate any degree of requirement for application of a procedure.

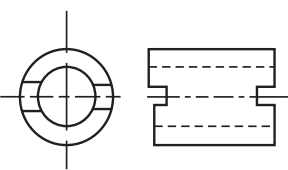
- Q1-7. What two manuals outline the chain-of-command responsibilities in regards to occupational safety?*
- Q1-8. What is the primary source of information involving the use of hazardous materials?*
- Q1-9. Who is responsible for training shop personnel in the use of the material safety data sheet?*
- Q1-10. In naval aviation technical manuals, what safety term is used to indicate an operating procedure, practice, or condition that may result in injury or death if not carefully observed?*

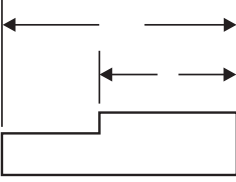
Q1-11. In naval aviation technical manuals, what safety term is used to indicate an operating procedure, practice, or condition that may result in damage or destruction to equipment?

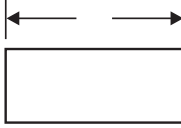
AIRCRAFT DRAWINGS

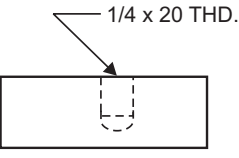
LEARNING OBJECTIVE: Recognize basic steps used in troubleshooting aircraft systems. Identify the various sources of available information.

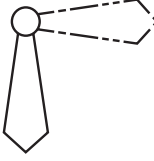
LINE STANDARDS			
NAME	CONVENTION	DESCRIPTION AND APPLICATION	EXAMPLE
VISIBLE LINES		HEAVY UNBROKEN LINES USED TO INDICATE VISIBLE EDGES OF AN OBJECT	
HIDDEN LINES		MEDIUM LINES WITH SHORT EVENLY SPACED DASHES USED TO INDICATE CONCEALED EDGES	
CENTER LINES		THIN LINES MADE UP OF LONG AND SHORT DASHES ALTERNATELY SPACED AND CONSISTENT IN LENGTH USED TO INDICATE SYMMETRY ABOUT AN AXIS AND LOCATION OF CENTERS	
DIMENSION LINES		THIN LINES TERMINATED WITH ARROWHEADS AT EACH END USED TO INDICATE DISTANCE MEASURED	
EXTENSION LINES		THIN UNBROKEN LINES USED TO INDICATE EXTENT OF DIMENSION	
LEADER LINES		THIN LINE TERMINATED WITH ARROWHEAD OR DOT AT ONE END USED TO INDICATE A PART, DIMENSION, OR OTHER REFERENCE	
PHANTOM OR DATUM LINE		MEDIUM SERIES OF ONE LONG DASH AND TWO SHORT DASHES EVENLY SPACED ENDING WITH LONG DASH USED TO INDICATE ALTERNATE POSITION OF PARTS, REPEAT DETAIL, OR TO INDICATE A DATUM PLANE	

AMf01003(A)

Figure 1-3.—Line characteristics.

Much of the information contained in the various manuals issued by the Naval Air Systems Command for Navy aircraft and equipment is in the form of schematic, block, and pictorial drawings or diagrams. To understand how a system or component of the aircraft functions, you must be able to read and understand these drawings and diagrams.







MEANING OF LINES

The alphabet of lines is the common language of the technician and the engineer. In drawing an object, a draftsman not only arranges the different views in a

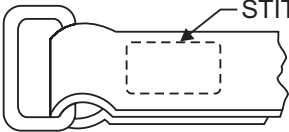
certain manner, but also uses different types of lines to convey information. Line characteristics, such as width, breaks in the line, and zigzags, have meanings, as shown in figure 1-3.

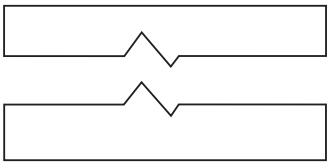
INTERPRETATION OF DRAWINGS

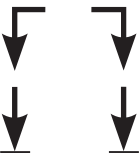
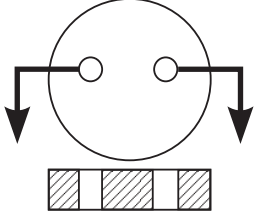
Schematic drawings are usually used to illustrate the various electrical circuits, hydraulic systems, fuel systems, and other systems of the aircraft. The components of an electrical circuit are normally represented by the standard electrical symbols shown

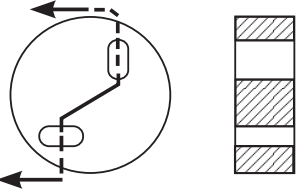
STITCH LINE		MEDIUM LINE OF SHORT DASHES EVENLY SPACED AND LABELED USED TO INDICATE STITCHING OR SEWING	
BREAK (LONG)		THIN SOLID RULED LINES WITH FREEHAND ZIG-ZAGS USED TO REDUCE SIZE OF DRAWING REQUIRED TO DELINEATE OBJECT AND REDUCE DETAIL	
BREAK (SHORT)		THICK SOLID FREEHAND LINES USED TO INDICATE A SHORT BREAK	
CUTTING OR VIEWING PLANE VIEWING PLANE OPTIONAL		THICK SOLID LINES WITH ARROWHEAD TO INDICATE DIRECTION IN WHICH SECTION OR PLANE IS VIEWED OR TAKEN	
CUTTING PLANE FOR COMPLEX OR OFFSET VIEWS		THICK SHORT DASHES USED TO SHOW OFFSET WITH ARROWHEADS TO SHOW DIRECTION VIEWED	

AMF0103(B)

Figure 1-3.—Line characteristics—Continued.

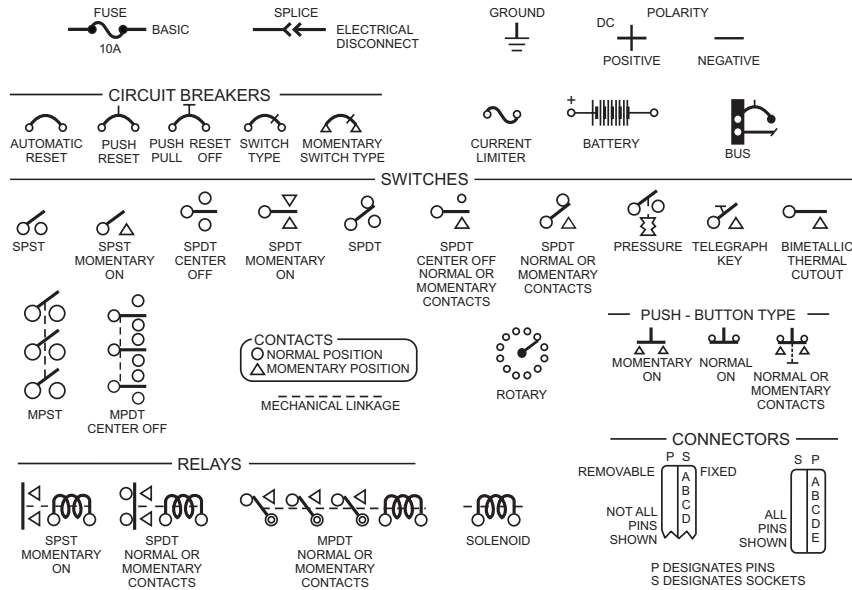

AMf01004

Figure 1-4.—Electrical symbols.

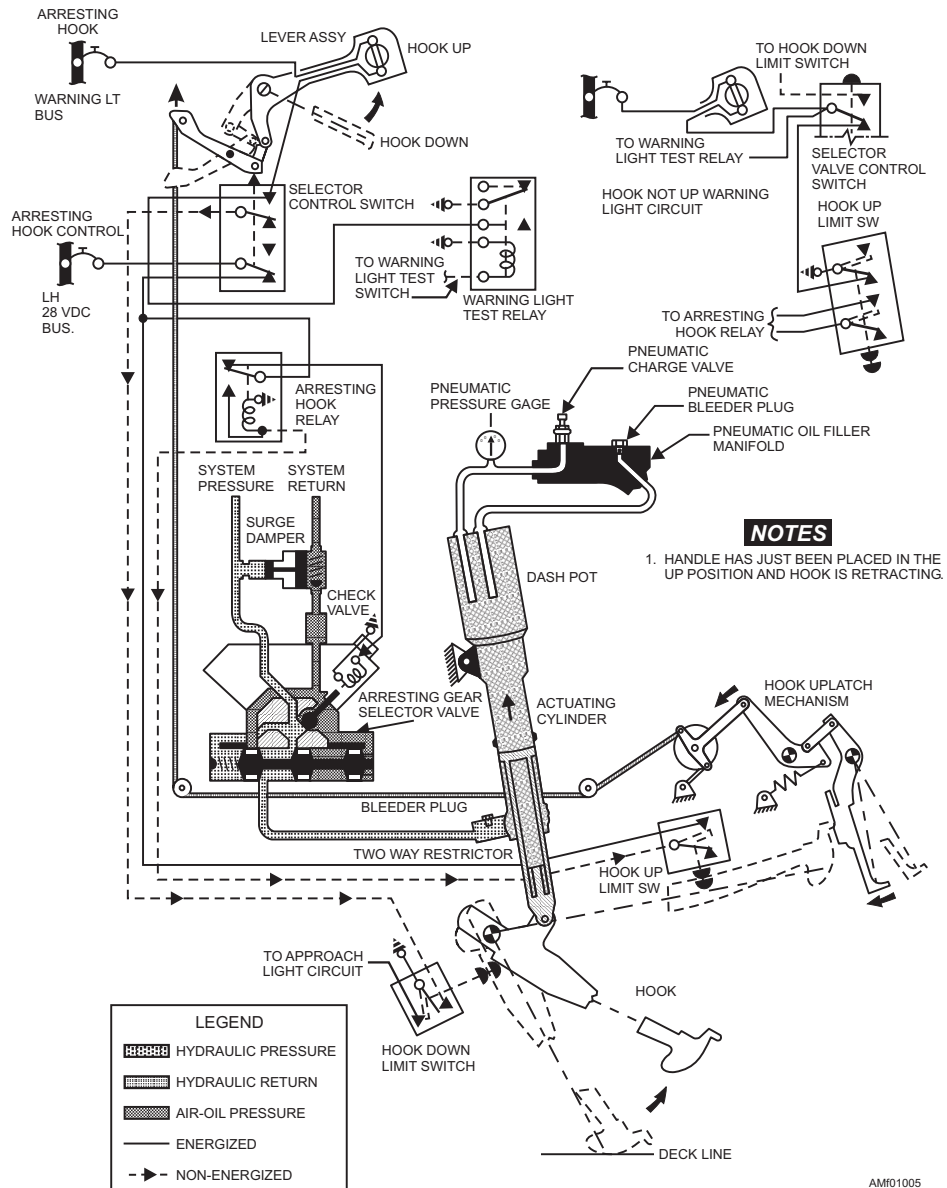

AMf01005

Figure 1-5.—Arresting gear system schematic.

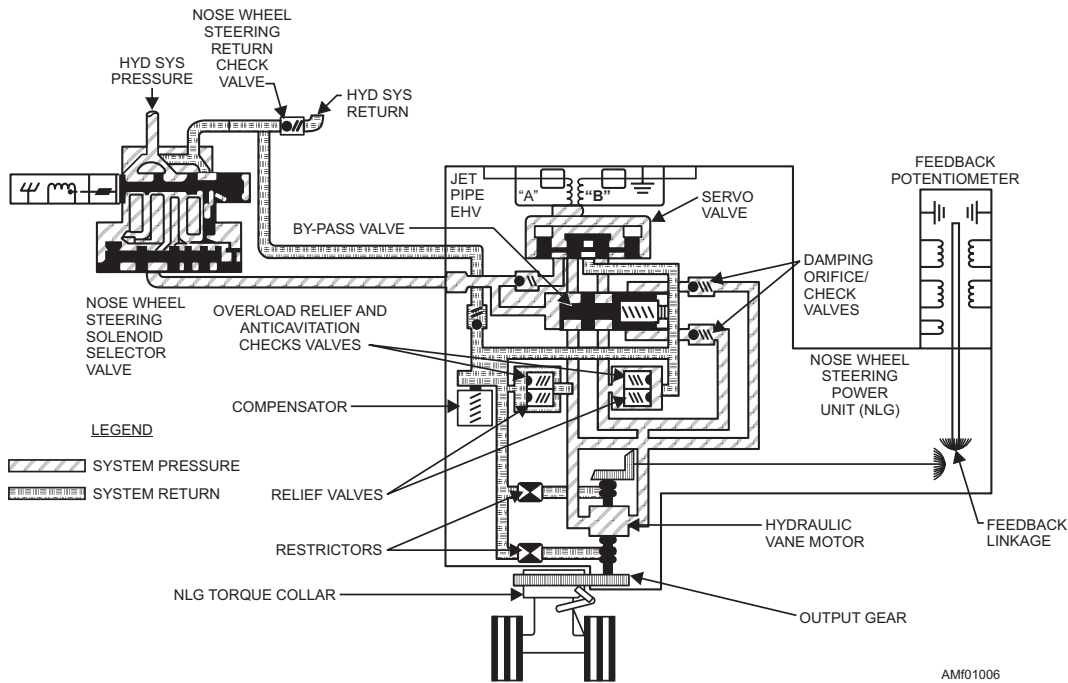

Figure 1-6.—Nosewheel steering system schematic.

in figure 1-4. Look at this figure and notice the electrical symbols for fuse, splice, ground, and polarity.

Figure 1-5 is a schematic diagram that shows an arresting gear system. Different symbols in the legend indicate the flow of hydraulic fluid. The diagram also indicates energized and nonenergized wires. Each component is illustrated and identified by name. Arrows indicate the movement of each component.

Block diagrams may be used to illustrate a system. The nosewheel steering system in figure 1-6 is a good example of the use of a block diagram.

In the block diagram, each of the components of the system is represented by a block. The name of the component represented by each block is near that block. Block diagrams are also useful in showing the relationship of the components. They also may show the sequence in which the different components operate.

A pictorial drawing is a representation of both the detail and the entire assembly. Figure 1-7 is an example of a pictorial drawing. Another use of this type of drawing is to show disassembly, or an exploded view. This type of drawing enables the mechanic to see how the parts of a particular piece of equipment are put together.

Orthographic drawings are used to show details of parts, components, and other objects, and are primarily used by the manufacturer of the object. Usually, two or more views of the object are given on the drawing.

Detailed instructions on reading orthographic, as well as all other types of drawings, are contained in *Blueprint Reading and Sketching*, NAVEDTRA 12014.

DIAGRAMS

One of the more important factors in troubleshooting a system logically is your understanding of the components and how they operate. You should study the information and associated schematics provided in the MIM. The function of each component and possible malfunctions can be used in the process of analyzing actual malfunction symptoms.

A primary concern in troubleshooting an aircraft hydraulic system is to determine whether the malfunction is caused by hydraulic, electrical, or mechanical failure. Actuating systems are dependent on the power systems. Some of the troubles exhibited

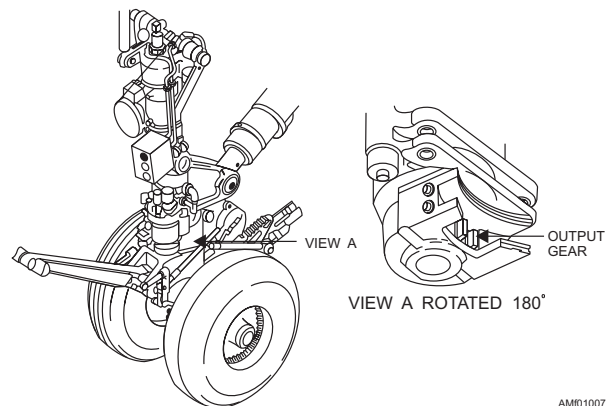

Figure 1-7.—Pictorial drawing with exploded view.

by an actuating system may be caused by difficulties in the power system. A symptom indicated by a component of the power system may be caused by leakage or malfunction of one of the actuating systems. When any part of the hydraulic system becomes inoperative, use the diagrams in conjunction with the checkout procedures provided in the aircraft MIM. Possible causes of trouble should always be eliminated systematically until the pertinent cause is found. No component should be removed or adjusted unless there is a sound reason to believe the unit is faulty.

There are two classes of diagrams you will be concerned with in gaining a complete knowledge of a specific system. These are the schematic and installation diagrams. A diagram, whether it is a schematic diagram or an installation diagram, may be defined as a graphic representation of an assembly or system.

Schematic Diagrams

Figure 1-8 is another example of a schematic diagram. Diagrams of this type do not indicate the actual physical location of the individual components

in the aircraft. They do locate components with respect to each other within the system. Various components are indicated by symbols in schematic diagrams, while drawings of the actual components are used in the installation (pictorial) diagrams. The symbols used in the schematic diagrams conform to the military standard mechanical symbols provided in MIL-STD-17B-1 and MIL-STD-17B-2. Most manufacturers improve upon these basic symbols by showing a cutaway portion on each component. These cutaways aid in clarifying the operation of that component. You should be able to trace the flow of fluid from component to component. On most diagrams of this type, an uncolored legend or different colors are used to represent the various lines. The legend identifies the lines in relation to their purpose and the mode of operation being represented. Each component is further identified by name, and its location within the system can be determined by noting which lines lead into and out of the component.

Since many systems are electrically controlled, you should be capable of reading the electrical portion of a schematic diagram. Knowledge of the electrical symbols and the use of a multimeter in making voltage

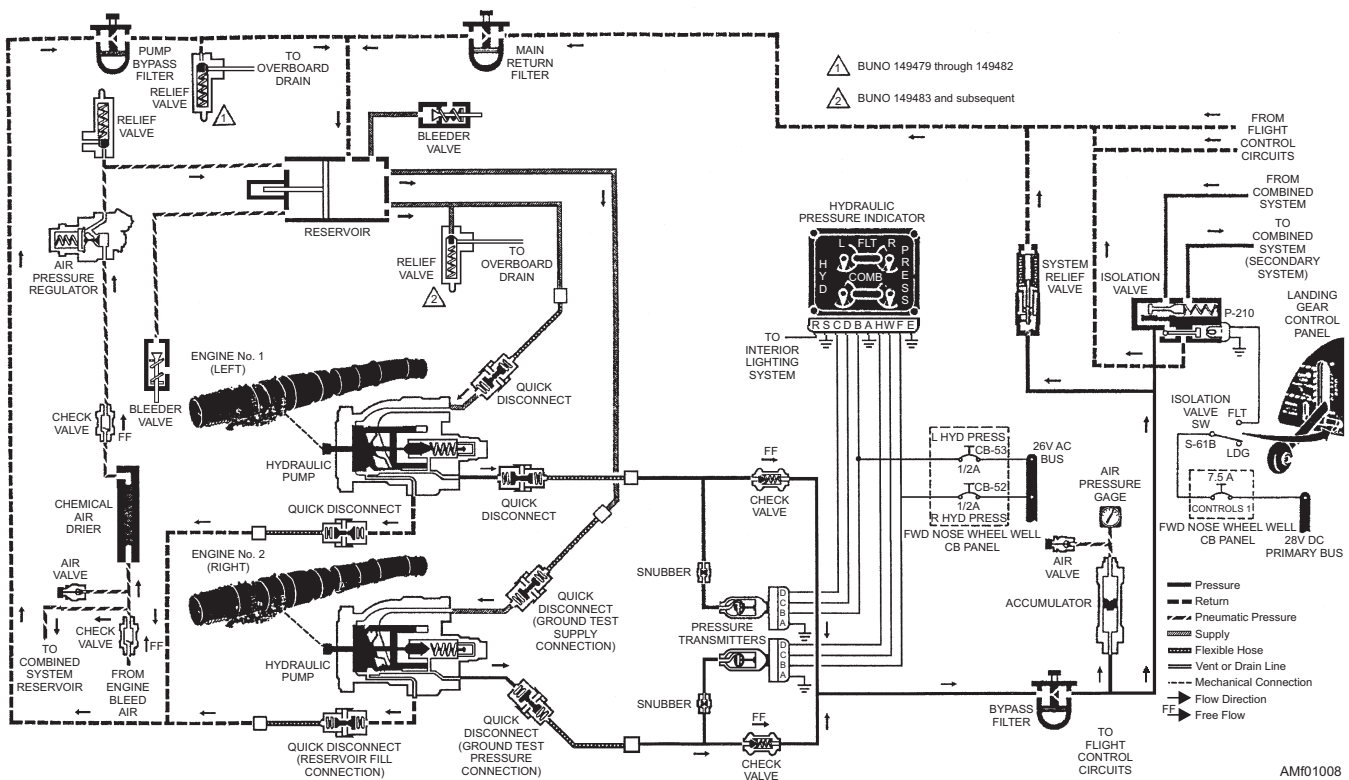

Figure 1-8.—Hydraulic system schematic.

and continuity checks will contribute significantly to efficient troubleshooting. If a malfunction is caused by electrical problems, the assistance of AE personnel may be required.

All electrical wiring in the aircraft is marked at specified intervals with a wire identification code. These identification codes are defined in the electrical volume(s) of the MIM, and they are useful in tracing wires throughout the aircraft. If an elusive malfunction is reasonably traced to or considered to be of an electrical nature, the electrical circuit should be checked by a qualified AE. Many wires can give a good continuity reading under a no-load or low-current condition and still be malfunctioning when under a load condition.

NOTE: Electrical schematics are especially useful in determining annunciator panel malfunctions.

Installation Diagrams

Figure 1-9 is an example of an installation diagram. This is a diagram of the motor-driven hydraulic pump installation. Installation diagrams show general location, function, and appearance of parts and assemblies. On some installation diagrams, letters on the principal view refer to a detailed view located elsewhere on the diagram. Each detailed view is an enlarged drawing of a portion of the system identifying each of the principal components for purposes of clarification. Diagrams of this type are invaluable to maintenance personnel in identifying and locating components. Installation diagrams will aid you in understanding the principle of operation of complicated systems.

Q1-12. What type of diagram is useful for showing the relationship of components of a system

and the sequence in which the different components operate?

Q1-13. What type of diagram is a graphic representation of a system that shows how a component fits with other components but does not indicate its actual location in the aircraft?

Q1-14. What type of diagrams use actual drawings of components within the system?

TROUBLESHOOTING AIRCRAFT SYSTEMS

LEARNING OBJECTIVE: Recognize the definition of troubleshooting. Identify the seven steps in the troubleshooting procedures.

Troubleshooting/trouble analysis may prove to be the most challenging part of system maintenance. Troubleshooting is the logical or deductive reasoning procedure used when you are determining what unit is causing a particular system malfunction. The MIM for each aircraft generally provides troubleshooting aids that encompass the following seven steps:

1. Conduct a visual inspection
2. Conduct an operational check
3. Classify the trouble
4. Isolate the trouble
5. Locate the trouble
6. Correct the trouble
7. Conduct a final operational check.

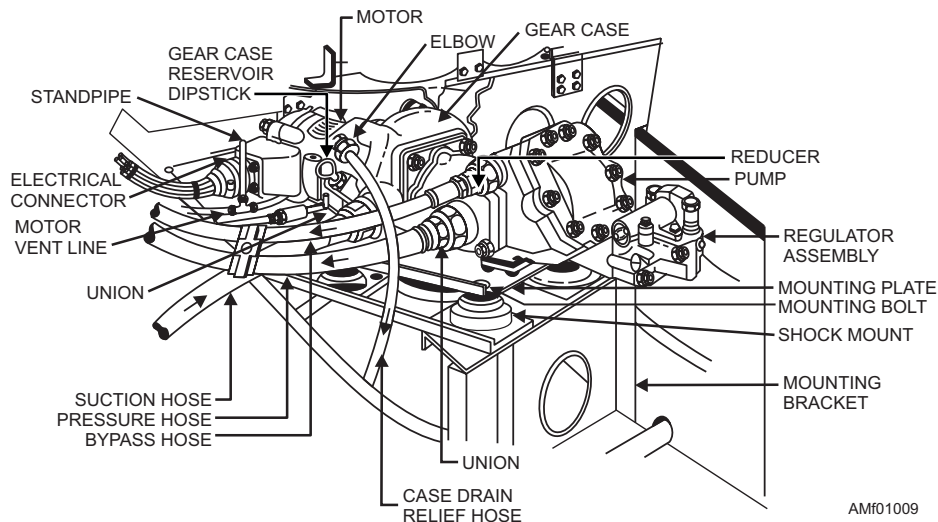

Figure 1-9.—Installation diagram of a motor-driven hydraulic pump.

Table 1-1 shows a representative troubleshooting table. The troubles in this table are numbered to correspond with the step of the operational check procedures where the trouble will become apparent.

Other MIMs use trouble analysis sheets to pursue a trouble to a satisfactory solution by the process of elimination. The symptom is defined in tabular form with a remedy for each symptom. An example of

Table 1-1.—Troubleshooting Flight Hydraulic Power System

Probable Cause	Isolation Procedure	Remedy
STEP 1 TROUBLE: RESERVOIR FLUID LEVEL INDICATOR INDICATES BELOW FULL		
Reservoir fluid level low.	Check reservoir fluid level.	Service hydraulic system reservoir.
STEP 2 TROUBLE: FILTER DIFFERENTIAL PRESSURE INDICATOR BUTTON UP		
Indicator button not properly reset.	Manually reset indicator button.	Operate hydraulic power system. If normal operation results, no further action required. If indicator button pops, clean and/or replace filter element.
STEP 3 TROUBLE: SYSTEM HYDRAULIC PRESSURE FAILS TO DEplete		
Accumulator pressure gauge defective.	Replace gauge with a known operative gauge.	If normal operation results after replacement, use replacement gauge.
STEP 4 TROUBLE: ACCUMULATOR PRESSURE GAUGE DOES NOT INDICATE 2,000 PSI		
Improper accumulator preload.	Deplete hydraulic system pressure, then check accumulator pressure preload.	Service accumulator preload.
Air filler valve.	Check air filler valve for leakage.	Retorque swivel nut or replace defective O-ring, defective filler valve.
Pneumatic lines.	Check pneumatic lines for leakage.	Retorque or replace faulty pneumatic line section.
Accumulator pressure gauge.	Replace gauge with a known operative gauge.	If normal operation results after replacement, use replacement gauge.
Accumulator.	Check accumulator for leakage.	Replace defective O-rings or defective accumulator.
STEP 5 TROUBLE: PILOT'S HYDRAULIC PRESSURE INDICATOR (UPPER LEFT DIAL) INDICATES BELOW 3,000 PSI		
Hydraulic lines.	Check hydraulic lines for leakage.	Retorque or replace faulty hydraulic line section.
Pilot's hydraulic pressure indicator.	Replace indicator with a known operative indicator. (Refer to NAVAIR 01-85ADA-2-5.)	If normal operation results after replacement, use replacement indicator.
Pressure transmitter.	Replace transmitter with a known operative transmitter. (Refer to NAVAIR 01-85ADA-2-5.)	If normal operation results after replacement, use replacement transmitter.

Table 1-2.—Troubleshooting Wheel Brake System

Probable Cause	Isolation Procedure	Remedy
Brake accumulator does not become charged		
Brake accumulator charge pressure low	Check that pressure gauge reads 800 psi.	Charge brake accumulator.
Pressure gauge	Replace pressure gauge with one known to operate properly. (Refer to WP084 00.)	If trouble is corrected, discard defective gauge.
Brake selector-valve rigging	Check selector-valve rigging. (Refer to WP082 00.)	Rig selector valve.
Brake accumulator	Replace accumulator with one known to operate properly. (Refer to WP083 00.)
Brake cycles gauge	Replace gauge with one known to operate properly. (Refer to WP086 00.)
Thermal relief valve	Replace relief valve with one known to operate properly. (Refer to WP087 00.)

trouble analysis sheets is shown in tables 1-2 and 1-3. The sheets used with the checkout procedures relate to checkout procedures by direct reference or to discrepancies occurring in flight or during ground operations. Each table provides a remedy for each symptom.

When the remedy is as simple as replacing a component or making an adjustment, this fact is so stated. When the remedy requires further analysis, the entry in the REMEDY column will be a reference to an applicable paragraph, figure, or possibly another manual. See tables 1-1 and 1-2.

Each trouble analysis procedure provides preliminary data, such as tools and equipment, manpower requirements, and material. In the block type of troubleshooting sheets, the procedure is arranged in the order of most likely occurrence. The sheet contains a NO-YES response to direct maintenance personnel through a logical series of steps. These directed responses assist in isolating the malfunction. When the requirements of a step are satisfactory, you go to the YES column and perform the referenced step. When the requirements of a step are not satisfactory, you go to the NO column and perform the referenced step. This method is continued until the malfunction is isolated and corrected. The original checkout procedure must then be repeated to ensure that the malfunction has been corrected.

TROUBLESHOOTING PROCEDURES

Troubleshooting procedures are similar in practically all applications, whether they are mechanical, hydraulic, pneumatic, or electrical. These

Table 1-3.—Troubleshooting Emergency/Parking Brake System

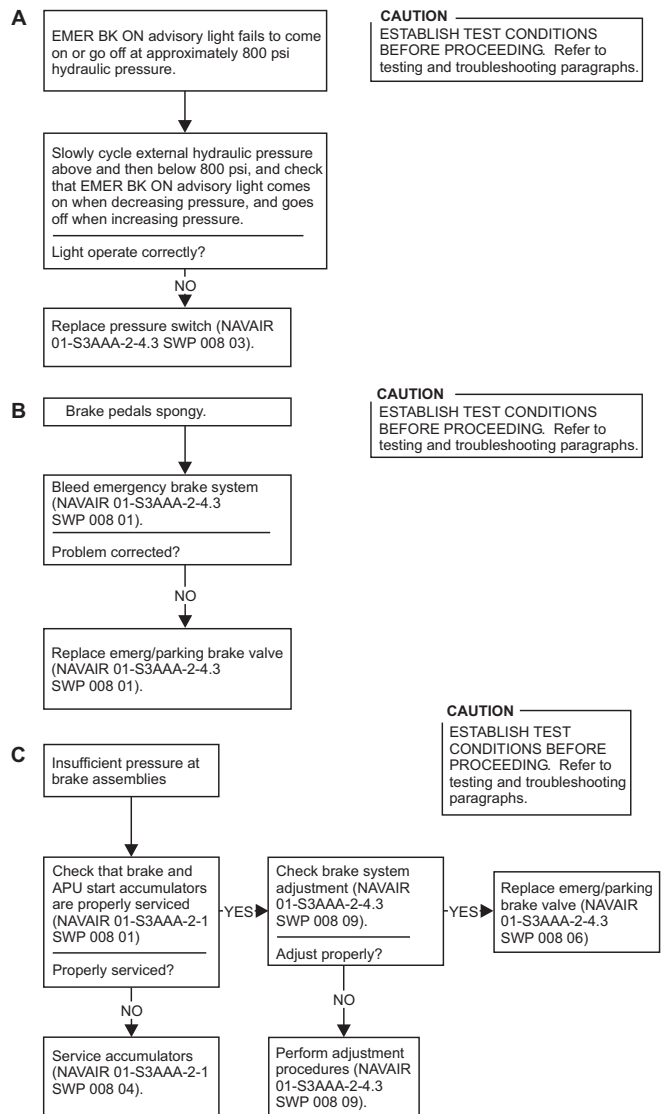

procedures are certainly adaptable to all aircraft maintenance, as well as other types of installations. Auto mechanics use these steps to find and repair malfunctions in automobiles. You will use the same procedure to find and repair malfunctions within aircraft systems.

Clarification of the seven distinct troubleshooting steps previously mentioned are as follows:

1. Conduct a visual inspection. This inspection should be thorough and searching to include checking all lines, units, mechanical linkage, and components for evidence of leaks, looseness, security, material condition, and proper installation. During this visual inspection, the hydraulic system should be checked for proper servicing, the reservoir for proper level, and accumulators for specified preload, etc.

2. Conduct an operational check. The malfunctioning system or subsystem is checked for proper operation. This is normally accomplished by attaching the support equipment to the aircraft, which supplies a source of electrical power and pressurized fluid to operate the hydraulic system. In some instances, however, the aircraft may be ground checked by using aircraft power and equipment. Whatever the case, during movement of the malfunctioning unit, the AM checks for external leakage, the correct direction of component movement, its proper sequence of operation, speed, and whether the complete cycle was obtained.

3. Classify the trouble. Malfunctions usually fall into four basic categories—hydraulic, pneumatic, mechanical, or electrical. By using the information gained from steps 1 and 2, you, the AM, can determine under which classification the malfunction occurs.

Something affecting normal flow of hydraulic fluid would be classified under the hydraulic classification. The flow of fluid may be affected by external and internal leakage, total or partial restriction, or improper lubrication.

Something affecting the normal flow of compressed gases is classified as a pneumatic malfunction. This type of malfunction stems from the same general sources as hydraulic malfunctions.

Most units that operate hydraulically or pneumatically incorporate mechanical linkage. If a discrepancy in the linkage exists, it will affect the system's operation. Mechanical discrepancies should be found during visual inspections, and they are usually in one of the following categories: worn linkages, broken linkages, improperly adjusted linkages, or improperly installed linkages.

Many hydraulic units incorporate electrical components to operate or control them. You must be able to determine if the electrical system is functioning normally; electrical malfunctions will usually be a complete power failure, circuit failure, or component failure.

4. Isolate the trouble. This step calls for sound reasoning, a full and complete knowledge of hydraulic theory, as well as a complete understanding of the affected hydraulic system. During this step, you must use your knowledge and the known facts to determine where the malfunction exists in the system. Usually the trouble can be pinned down to one or two areas. Eliminating those units that could not cause the known symptoms and those that can be proved to be operating normally will usually identify the malfunction.

5. Locate the trouble. This step is used to eliminate unnecessary parts removal, thus saving money, valuable time, and man-hours. Often, you have determined what unit or units in the system could have caused the malfunction, thus verifying the isolation step.

Both hydraulic and pneumatic malfunctions are verified in the same manner. You remove lines and inspect them for the correct flow in or at the suspected unit. Internal leaks may occur in valves, actuators, or other hydraulic units. Any unit that has a line that could carry fluid to "return" is capable of internal leakage.

Mechanical malfunctions are located by closely observing the suspected unit to see if it is operating in accordance with the applicable aircraft MIM. Mechanical discrepancies are usually located during the visual inspection in step 1.

Electrical malfunctions are located, with the assistance of AEs, by tracing electrical power requirements throughout the affected system.

6. Correct the trouble. This step is accomplished only after the trouble has been definitely located and there is no doubt that your diagnosis is correct. Malfunctions are usually corrected by replacement of units or components, rigging and adjustments, and bleeding and servicing.

NOTE: Always check the applicable MIM for CAUTION, WARNING, and SAFETY notes concerning maintenance procedures.

7. Conduct a final operational check. The affected system must be actuated a minimum of five times, or until a thorough check has been made to determine that its operation and adjustments are satisfactory.

TESTING AND OPERATIONAL CHECKS

Aircraft systems tests and operational checks should be performed under conditions as nearly operational as possible. Such tests or checks should be performed in accordance with the instructions outlined in the applicable MIM. Make the operational checks in the sequence outlined in the MIM. Any discrepancies you find when performing a step should be corrected before proceeding. The operational check and the troubleshooting charts have been coordinated so that malfunctions can be isolated in an efficient manner. If the troubleshooting aids do not list the trouble being experienced, you will have to study the system schematics and perform the operational check. Use logic and common sense in pinpointing the cause of the malfunction. The test stand to be used in performing the operational check must be capable of producing the required flow and pressure required for proper operation. Check all electrical switches and circuit breakers, as well as hydraulic selector valves, for proper position. Perform this check before applying external electrical and hydraulic power. Perform all maintenance in accordance with the MIM. Observe all maintenance precautions and requirements for quality assurance verification.

Personnel involved in troubleshooting and performing operational checks should consult the records maintained in maintenance control and/or the

work center register. Reference to records of previous maintenance may show a progressive deterioration of a particular system or a previous discrepancy. This procedure could be helpful in pinpointing the cause of the malfunction currently being experienced.

ELECTRICAL FAILURES

Since practically all systems now have some electrically controlled components, troubleshooting must also include the related electrical circuits in many instances. Although an AE is generally called upon to locate and correct electrical troubles, you should be able to check circuits for loose connections and even perform continuity checks when necessary. Therefore, a knowledge of electrical symbols and the ability to read circuit diagrams is necessary. Figure 1-4 illustrates the electrical symbols commonly found in schematic diagrams.

Loose connections are located by checking all connectors in the circuit. A connector that can be turned by hand is loose and should be tightened hand tight.

A continuity check is simply a matter of determining whether or not the circuit to the selector valve, or other electrically controlled unit, is complete. Continuity checks are made with the use of a multimeter. The name multimeter comes from MULTIPLE METER, and that is exactly what a multimeter is. It is a dc ammeter, an ac ammeter, a dc voltmeter, an ac voltmeter, and an ohmmeter, all in one package. Figures 1-10 and 1-11 show the faces of

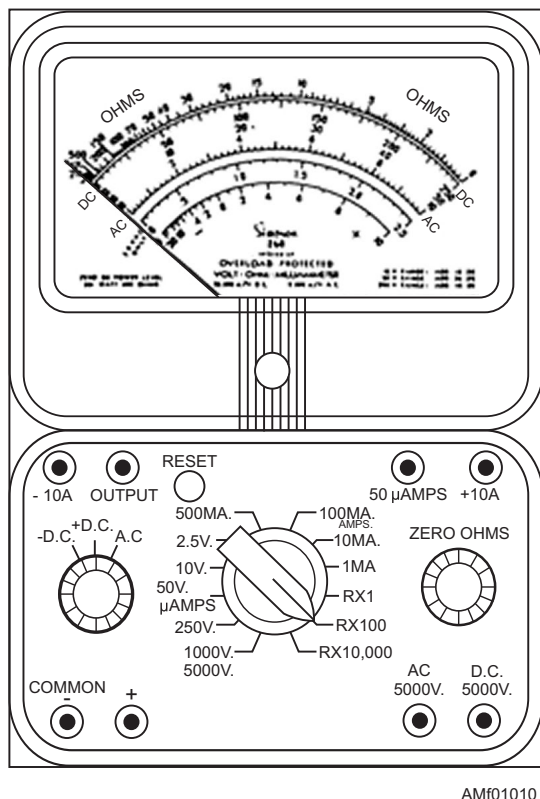

Figure 1-10.—A typical multimeter.

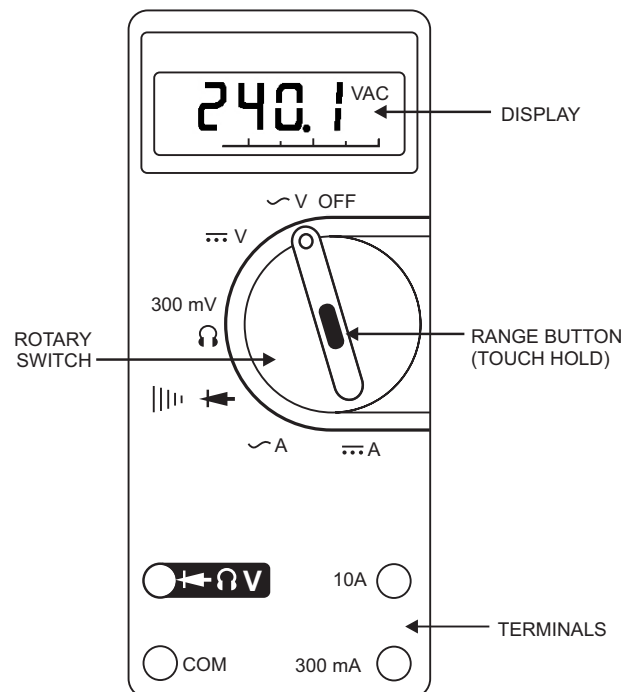

Figure 1-11.—A typical electronic multimeter.

commonly used multimeters. The applicable instructions should be consulted prior to equipment operation.

Q1-15. The logical/deductive reasoning process of finding a malfunction is known by what term?

Q1-16. What are the seven steps encompassed in the troubleshooting aids generally found in the aircraft MIMS?

Q1-17. During a visual inspection, a hydraulic system should be checked for what primary concerns?

Q1-18. What are the four basic categories of malfunctions?

Q1-19. When you conduct the final operational check, how many times must the affected system be actuated?

Table 1-4.—Common Military Lubricants and Their Use

TITLE AND SPECIFICATION	RECOMMENDED TEMPERATURE RANGE	GENERAL COMPOSITION	INTENDED USE
MIL-G-23827 [Grease, Aircraft, Synthetic, Extreme Pressure]	-100° to 250°F	Thickening agent, low-temperature synthetic oils, or mixtures EP additive	Actuator screws, gears, controls, rolling-element bearings, general instrument use
MIL-G-21164 [Grease, Aircraft, Synthetic, Molybdenum Disulfide]	-100° to 250°F	Similar to MIL-G-23827 plus molybdenum disulfide	Sliding steel on steel heavily loaded hinges, rolling element bearing where specified
MIL-G-81322 [Grease, Aircraft, General Purpose, Wide Temperature Range]	-65° to 350°F	Thickening agent and synthetic hydrocarbon. Has cleanliness requirements	O-rings, certain splines, ball and roller bearing assemblies, primarily wheel bearings in internal brake assemblies and where compatibility with rubber is required
MIL-G-4343 [Grease, Pneumatic System]	-65° to 200°F	Thickening agent and blend of silicone and diester	Rubber to metal lubrication: pneumatic and oxygen systems
MIL-G-25537 [Grease, Helicopter Oscillating Bearing]	-65° to 160°F	Thickening agent and mineral oil	Lubrication of bearings having oscillating motion of small amplitude
MIL-G-6032 [Grease, Plug Valve, Gasoline and Oil Resistant]	32° to 200°F	Thickening agent, vegetable oils, glycerols, and/or polyesters	Pump bearings, valves and fittings where specified for fuel resistance
MIL-G-27617 [Grease, Aircraft Fuel and Oil Resistant]	-30° to 400°F	Thickening agent and fluorocarbon or fluorosilicone	Tapered plug and oxygen system valves; certain fuel system components; antiseize
MIL-G-25013 [Grease, Ball and Roller Bearing, Extreme High Temp]	-100° to 450°F	Thickening agent and silicone fluid	Ball and roller bearing lubrication

- Q1-20. What components should be checked for proper position prior to applying electrical and hydraulic power?
- Q1-21. When troubleshooting, what records should you check to see if there is a previous history of the same type of discrepancy?
- Q1-22. What equipment or tool should you use to check the voltage and continuity of a circuit in an electrically controlled hydraulic system?

LUBRICATION

LEARNING OBJECTIVE: Identify the different types of lubricants. Recognize the different methods of application. Understand the use of lubrication charts.

Perhaps the only connection you have had with lubrication was taking the car to the garage for greasing and oil change. If your car has burned out a bearing, you have learned the importance of lubricants. The proper lubrication of high-speed aircraft is very important. You should be familiar with the various types of lubricants, their specific use, and the method and frequency of application.

Lubricants are used to reduce friction, to cool, to prevent wear, and to protect metallic parts against corrosion. In the aircraft, lubrication is necessary to minimize friction between moving parts. Only the presence of a layer or film of lubricant between metal surfaces keeps the metals from touching. As a result, friction is reduced between moving parts. Prolonged operating life is ensured when the lubricant keeps metal surfaces from direct contact with each other. If the film disappears, you end up with burned out or frozen

bearings, scored cylinder walls, leaky packings, and a host of other troubles. Appropriate use of proper lubricants minimizes possible damage to equipment.

LUBRICANTS

You can get lubricants in three forms. They are fluids, semisolids, and solids. Additives improve the physical properties or performance of a lubricant. We all know that oils are fluids, and greases are semisolids. You probably think of graphite, molybdenum disulfide, talc, and boron nitride as additives. In fact, they are solid lubricants. A solid lubricant's molecular structure is such that its platelets will readily slide over each other. Solid lubricants can be suspended in oils and greases.

There are many different types of approved lubricants in use for naval aircraft. Because the lubricants used will vary with types of aircraft and equipment, it is impractical to cover each type. Some of the more common types are described in table 1-4.

Methods of Application

Different types of lubricants may be applied by any one of several methods. Common methods are by grease gun, by oil/squirt cans, by hand, and by brush.

GREASE GUNS.—There are numerous types and sizes of grease guns available for different equipment applications. The lever and one-handed lever guns are two of the most common types in use. The grease gun may be equipped with a flexible hose instead of a rigid extension. Different nozzles can be attached to the grease guns for different types of fittings. See figure 1-12.

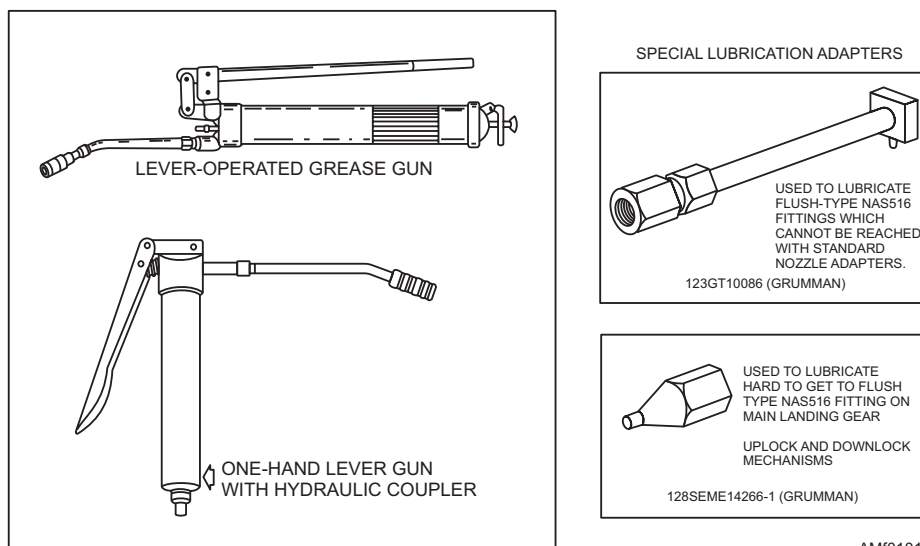

Figure 1-12.—Types of grease guns.

AMF01012

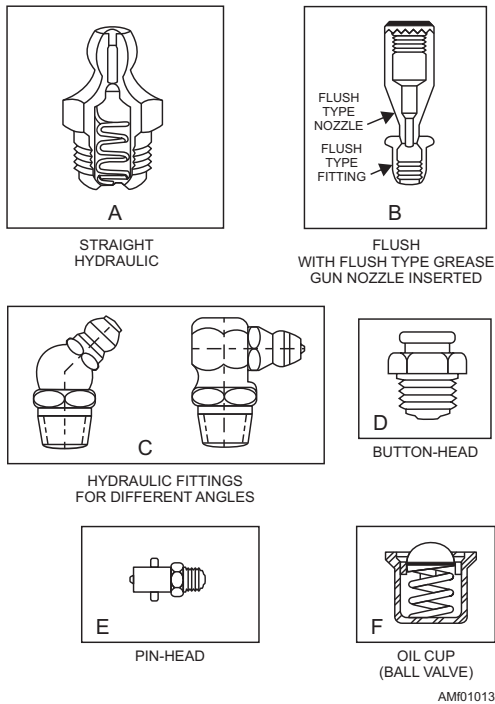

Figure 1-13.—Types of lubrication fittings.

OIL/SQUIRT CAN.—The oil/squirt cans are used for general lubrication. Always use the specified oil for the part being lubricated. Before using an oil can, always check to make sure the oil can contains the proper lubricant.

HAND.—This method of lubrication is generally used for packing wheel bearings. It involves using grease in the palm of your hand to pack the bearings.

BRUSH.—This method of lubrication is used when it is necessary to cover a large area, or for coating tracks or guides with a lubricant.

Lubrication Fittings

There are several different types of grease fittings. They are the hydraulic (Zerk fitting), the buttonhead pin, and flush type of fittings. See figure 1-13. The two most commonly used fittings in naval aviation are the hydraulic- and flush-type fittings. These fittings are found on many parts of the aircraft.

HYDRAULIC FITTINGS.—This type protrudes from the surface into which it is screwed, and it has a rounded end that the mating nozzle of the grease gun

SURFACE TREATMENT		
IDENTIFICATION LETTERS	SPECIFICATION	TYPE OF LUBRICANT/ COMPOUND
BRW	MIL-G-81322	GREASE AIRCRAFT, GENERAL, PURPOSE, WIDE TEMPERATURE RANGE.
GIA	MIL-G-23827	GREASE AIRCRAFT AND INSTRUMENT, GEAR AND ACTUATOR SCREW.
GMD	MIL-G-21164	GREASE, MOLYBDENUM DISULFIDE (FOR LOW AND HIGH TEMPERATURE).
OAI	MIL-L-6085	LUBRICATING OIL; AIRCRAFT INSTRUMENT, LOW VOLATILITY.
OHA	MIL-H-83282	HYDRAULIC FLUID, FIRE RESISTANT SYNTHETIC HYDROCARBON BASE, AIRCRAFT.
OHT	MIL-H-6083	HYDRAULIC FLUID, PETROLEUM BASE, PRESERVATIVE
PL-SPECIAL	VV-L-800	LUBRICATING OIL, GENERAL PURPOSE, PRESERVATIVE (WATER DISPLACING, LOW TEMPERATURE).
GOS	MIL-L-10324A OR SILOGRAM APG 75 (ALTERNATE)	LUBRICATING OIL, GEAR, SUB-ZERO
†(NONE)	MIL-C-16173	CORROSION PREVENTIVE COMPOUND SOLVENT CUTBACK COLD APPLICATION
††(NONE)	MIL-C-81309	CORROSION PREVENTIVE COMPOUND WATER DISPLACING, ULTRA-THIN FILM
NONE	P-D-680 TYPE 11	DRYCLEANING SOLVENT

APPLICATION SYMBOLS

PRESSURE GUN (SEE HIGH PRESSURE APPLICATION)	PRESSURE GUN (SEE LOW PRESSURE APPLICATION)	ZERK FITTING	FLUSH FITTING	OIL CAN	HAND	BRUSH
--	---	--------------	---------------	---------	------	-------

HIGH PRESSURE APPLICATION

NIPPLE-TYPE FITTING (MS 15001) REQUIRE HIGH PRESSURE APPLICATION

LOW PRESSURE APPLICATION

FLUSH-TYPE FITTINGS (NAS-516) REQUIRE LOW PRESSURE APPLICATION

Figure 1-14.—Lubrication chart.

AM01014

grips. A spring-loaded ball acts as a check valve. Figure 1-13 shows a cross-sectional view of a straight hydraulic fitting and an angled hydraulic fitting made for lubricating parts that are hard to reach.

FLUSH FITTINGS.—This type of fitting sets flush with the surface into which it is placed. It will not interfere with moving parts. Figure 1-13 shows a cutaway view of a flush-type fitting and the adapter nozzle used on the grease gun.

LUBRICATION SELECTION

How do you know what grease or oil to select for a particular application? Lubrication instructions are issued for all equipment requiring lubrication. You will find that the MIM or MRCs provide you with lubrication information. In the event that the exact

lubricant is not available and a substitution is not listed, request substitution through the chain of command.

LUBRICATION CHARTS

The lubrication requirements for each model of aircraft are given in the “General Information and Servicing” section of the MIM. In the MIM you will find the necessary support equipment and consumable material requirements. A table/chart similar to the one shown in figure 1-14 lists all of the various types of lubricants used in lubricating the whole aircraft. Additional information, such as application symbols, specification numbers, and symbols are provided in this table.

You should use the Maintenance Requirements Cards (MRCs) as a guide to the lubrication of aircraft. Figure 1-15 shows the front and back of these cards,

CARD 24		Date 1 August 1987			CHANGE NO. 2	SPECIAL 14 DAY	ELEC PWR OFF
WORK AREA/ZONE	C R S N	TIME 0.1	RTG. AMH NO. 1	MOS. 6057 NO. 1	NOSE LANDING GEAR LUBRICATION	HYD PWR OFF	COND AIR NA
<p>NOTE: Tasks shall be accomplished prior to and after aircraft cleaning.</p> <p>GROUND SUPPORT EQUIPMENT REQUIRED</p> <p>Oiler, Hand GGG000591, Type 2, Class B Style B Unit, Lubrication MILL7312</p> <p>CONSUMABLES/REPLACEMENT PARTS</p> <p>Cloth, Cleaning CCC-C46, Type 1, Class 4 Compound, Corrosion Preventative, Water Resistant MIL-C-81309, Type 2, Class 2 Grease, Aircraft, General Purpose MIL-G-81322 Oil, Lubricating, General Purpose V V-L-800</p> <p>NOTE: All lubrication points and surface must be cleaned prior to application of lubricant; and wiped clean of excess lubricant upon completion.</p> <p style="text-align: right;">Continued</p>							

CARD 24.1		Date 1 August 1987			CHANGE NO. 2	SPECIAL 14 DAY	ELEC PWR OFF																																												
WORK AREA/ZONE	C R S N	TIME	RTG. AMH NO. 1	MOS. 6057 NO. 1	NOSE LANDING GEAR LUBRICATION	HYD PWR OFF	COND AIR NA																																												
3	<p>1. Lubricate nose landing gear as follows:</p> <table border="1"> <thead> <tr> <th>ITEM</th> <th>NOMENCLATURE</th> <th>NO. OF POINTS</th> <th>SPECIFICATION</th> </tr> </thead> <tbody> <tr> <td>1.</td> <td>Trunnion Post Fittings</td> <td>2</td> <td>MIL-G-81322</td> </tr> </tbody> </table> <p>NOTE: Access to Item 2 requires fuselage cover removal.</p> <table border="1"> <tbody> <tr> <td>2.</td> <td>Drag Brace (Aft End)</td> <td>2</td> <td>MIL-G-81322</td> </tr> <tr> <td>3.</td> <td>Holdback Adapter Attach Point</td> <td>1</td> <td>MIL-G-81322</td> </tr> <tr> <td>4.</td> <td>Holdback Adapter Pivot</td> <td>1</td> <td>MIL-C-81309</td> </tr> <tr> <td>5.</td> <td>Holdback Adapter Lugs</td> <td>2</td> <td>MIL-G-81322</td> </tr> <tr> <td>6.</td> <td>Launch Bar Attach Points</td> <td>2</td> <td>MIL-G-81322</td> </tr> <tr> <td>7.</td> <td>Launch Bar</td> <td>2</td> <td>MIL-G-81322</td> </tr> <tr> <td>8.</td> <td>Tie Down Rings</td> <td>2</td> <td>V V-L-800</td> </tr> <tr> <td>9.</td> <td>Drag Brace Attach Points</td> <td>2</td> <td>MIL-G-81322</td> </tr> <tr> <td>10.</td> <td>Drag Brace (Fwd End)</td> <td>1</td> <td>MIL-G-81322</td> </tr> </tbody> </table> <p style="text-align: right;">Continued</p>							ITEM	NOMENCLATURE	NO. OF POINTS	SPECIFICATION	1.	Trunnion Post Fittings	2	MIL-G-81322	2.	Drag Brace (Aft End)	2	MIL-G-81322	3.	Holdback Adapter Attach Point	1	MIL-G-81322	4.	Holdback Adapter Pivot	1	MIL-C-81309	5.	Holdback Adapter Lugs	2	MIL-G-81322	6.	Launch Bar Attach Points	2	MIL-G-81322	7.	Launch Bar	2	MIL-G-81322	8.	Tie Down Rings	2	V V-L-800	9.	Drag Brace Attach Points	2	MIL-G-81322	10.	Drag Brace (Fwd End)	1	MIL-G-81322
ITEM	NOMENCLATURE	NO. OF POINTS	SPECIFICATION																																																
1.	Trunnion Post Fittings	2	MIL-G-81322																																																
2.	Drag Brace (Aft End)	2	MIL-G-81322																																																
3.	Holdback Adapter Attach Point	1	MIL-G-81322																																																
4.	Holdback Adapter Pivot	1	MIL-C-81309																																																
5.	Holdback Adapter Lugs	2	MIL-G-81322																																																
6.	Launch Bar Attach Points	2	MIL-G-81322																																																
7.	Launch Bar	2	MIL-G-81322																																																
8.	Tie Down Rings	2	V V-L-800																																																
9.	Drag Brace Attach Points	2	MIL-G-81322																																																
10.	Drag Brace (Fwd End)	1	MIL-G-81322																																																

CARD 24.2		Date 1 August 1987			CHANGE NO.	SPECIAL 14 DAY	ELEC PWR OFF																				
WORK AREA/ZONE	C R S N	TIME	RTG. AMH NO. 1	MOS. 6057 NO. 1	NOSE LANDING GEAR LUBRICATION	HYD PWR OFF	COND AIR NA																				
	<table border="1"> <thead> <tr> <th>ITEM</th> <th>NOMENCLATURE</th> <th>NO. OF POINTS</th> <th>SPECIFICATION</th> </tr> </thead> <tbody> <tr> <td>11.</td> <td>Lower Torque Arm (Aft End)</td> <td>2</td> <td>MIL-G-81322</td> </tr> <tr> <td>12.</td> <td>Upper Torque Arm (Aft End)</td> <td>1</td> <td>MIL-G-81322</td> </tr> <tr> <td>13.</td> <td>Lower Torque Arm (Fwd End)</td> <td>2</td> <td>MIL-G-81322</td> </tr> <tr> <td>14.</td> <td>Upper Torque Arm (Fwd End)</td> <td>2</td> <td>MIL-G-81322</td> </tr> </tbody> </table> <p style="text-align: right;">Continued</p>							ITEM	NOMENCLATURE	NO. OF POINTS	SPECIFICATION	11.	Lower Torque Arm (Aft End)	2	MIL-G-81322	12.	Upper Torque Arm (Aft End)	1	MIL-G-81322	13.	Lower Torque Arm (Fwd End)	2	MIL-G-81322	14.	Upper Torque Arm (Fwd End)	2	MIL-G-81322
ITEM	NOMENCLATURE	NO. OF POINTS	SPECIFICATION																								
11.	Lower Torque Arm (Aft End)	2	MIL-G-81322																								
12.	Upper Torque Arm (Aft End)	1	MIL-G-81322																								
13.	Lower Torque Arm (Fwd End)	2	MIL-G-81322																								
14.	Upper Torque Arm (Fwd End)	2	MIL-G-81322																								

AM01015

Figure 1-15.—Typical lubrication MRC.

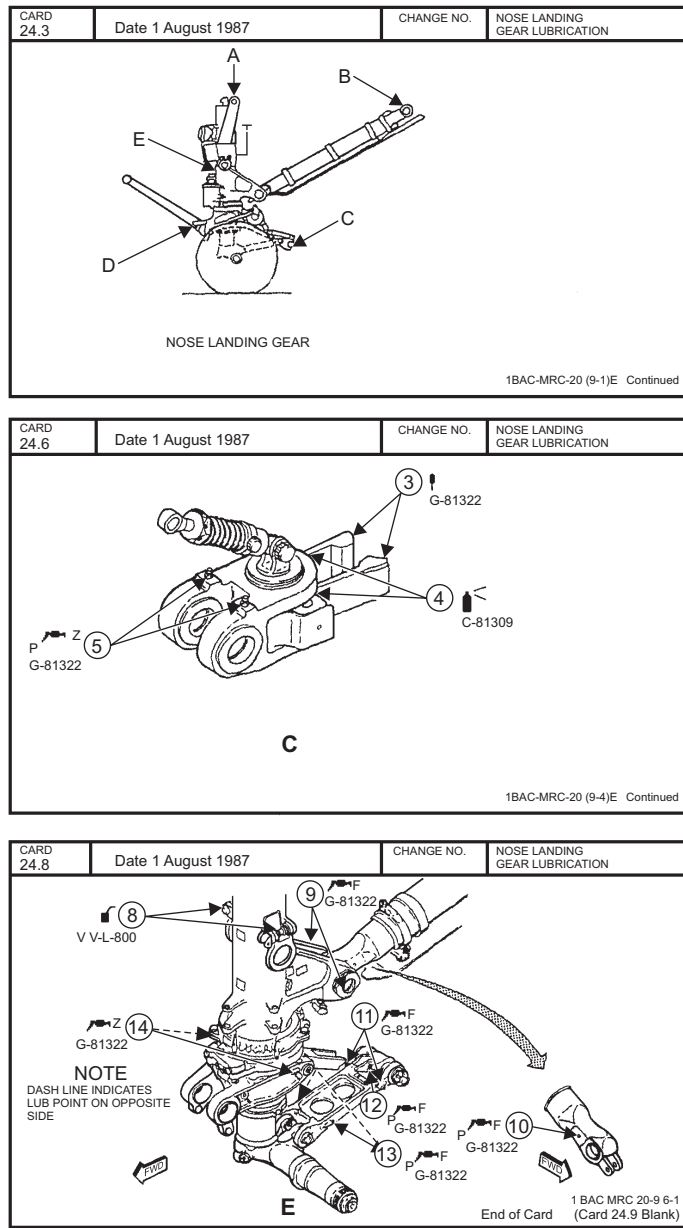

Figure 1-15.—Typical lubrication MRC—Continued.

which cover one specific area of aircraft lubrication. The top section of the card gives the card number, MRC publication number, frequency of application, time to do this section of cards, manpower required, name of area being lubricated, and if you need electrical/hydraulic power. The card illustrates the unit to be lubricated, and the number and types of fittings. The type of grease or oil to be used is listed with each item.

Prior to lubricating any parts, consult the MIMs or MRCs for proper equipment and type of lubricant. Consult the MSDS for any special safety precautions. Remove all foreign matter from joints, fittings, and bearing surfaces. A clean, lint-free cloth soaked with a

cleaning solvent may be used for this purpose. The lubricant should be applied sparingly to prevent accumulation of dust, dirt, and other foreign matter.

When you apply lubricants through pressure-type fittings with a grease gun, make sure the lubricant appears around the bushing. If no grease emerges around the bushing, check the fitting and grease gun for proper operation. You should make sure the grease gun is properly attached to the fitting, and wipe up all excess grease when done. If the flush-type fitting is being used, the grease gun must be equipped with the flush-type adapter. Hold the adapter perpendicular to the surface of the fitting when you use the gun. A 15-degree variation is permitted.

- Q1-23. What substance is used to reduce friction, cool metallic parts, prevent wear, and protect against corrosion?
- Q1-24. What are the four methods of applying lubricants?
- Q1-25. What type of lubrication fittings rests level with the surface and will not interfere with moving parts?
- Q1-26. Where would you find the prewash lubrication chart for a particular aircraft?
- Q1-27. What document should you consult for special safety requirements and personal protective equipment prior to using any lubricant?

WEIGHING AND BALANCING AIRCRAFT

LEARNING OBJECTIVE: Identify the various methods of weighing aircraft. Recognize the flight characteristics of the improperly weighed or balanced aircraft.

Flight characteristics of aircraft are directly dependent upon their weight and balance conditions. An aircraft whose weight is greater than its allowable maximum gross weight, or whose center of gravity (cg) is located outside its prescribed cg limits, may experience one or more unsatisfactory flight characteristics. Some of these conditions are

longitudinal instability, increase in takeoff distance, increase in control forces, increase in stall speeds, decrease in flight range, and a decrease in rate of climb. The requirements, procedures, and responsibilities for aircraft weight and balance control are defined in the technical manual, *USN Aircraft Weight and Balance Control*, NAVAIR 01-1B-50. Additional requirements and/or procedural instructions for specific type/model/series aircraft weight and balance control are specified in the aircraft's NATOPS manuals and the technical manual, *Weight and Balance Data*, NAVAIR 01-1B-40. In case of conflicting requirements, procedures, or instructions, OPNAVINST 4790.2 and the NATOPS manual take precedence over NA 01-1B-50 and NA 01-1B-40. NA 01-1B-50 takes precedence over the NA 01-1B-40, pending mandatory resolution of the conflict through the procedures described in the NA 01-1B-50.

WEIGHT

One of the basic elements of aircraft design is aircraft weight and balance. The estimated weight and balance of an aircraft is used in determining such design criteria as engine requirements, wing area, landing gear requirements, and payload capacity. Any weight change, either in manufacturing, modification, or maintenance, will have distinct effects on aircraft performance and/or payload capability. Figure 1-16

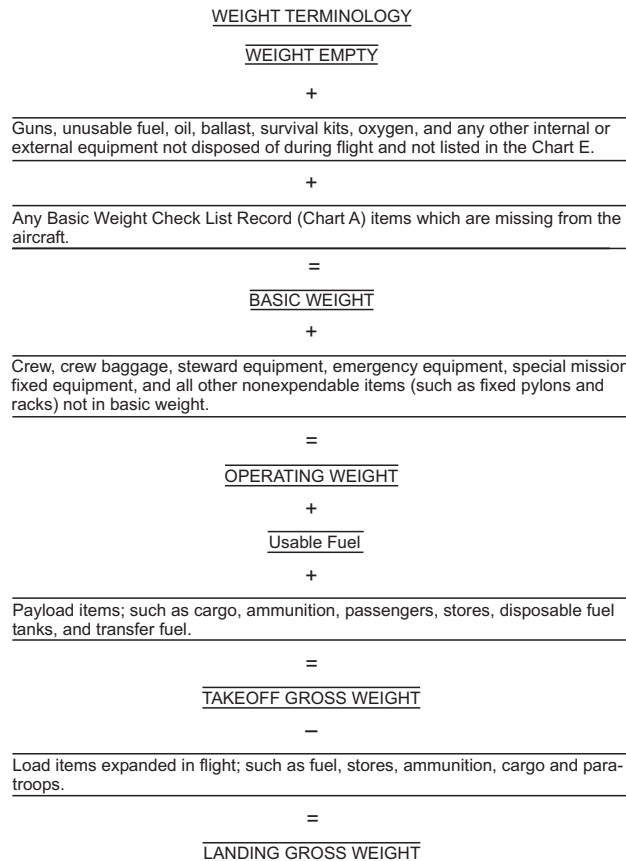

AM0016

Figure 1-16.—Weight terminology.

shows the meaning of and relationships between aircraft weight terminology. All aircraft are designed with a number of weight limits. Performance, control, and structural restrictions determine these limits. Exceeding these limits may result in a loss of the aircraft, and is expressly forbidden.

If the aircraft's actual weight exceeds the design weight, the result is reductions in performance and/or payload. An increase in gross weight increases takeoff speed, stalling speed, and landing ground run. The rate of climb, ceiling, and range decreases with increasing gross weight. If the operating weight increases while performance requirements remain the same, then the payload and/or fuel load must decrease. The weight of an aircraft is determined through a combination of actual weighing, accurate record keeping, and proper use of the aircraft's NAVAIR 01-1B-40.

Weighing Scales

A variety of scales and equipment may be used for weighing aircraft. At the present time, the method that has become the standard is the Mobile Electronic Weighing System (MEWS). Weighing systems now being used to weigh Navy aircraft are the MEWS, the heavy-duty portable scales, and the stationary pit-type scales.

MOBILE ELECTRONIC WEIGHING SYSTEM (MEWS).—This system, shown in figure 1-17, is designed to provide weight data and compute the center of gravity of aircraft (as well as wheeled vehicles

and cargo loads). The complete system is portable and includes a trailer for storage and transport, or it is mounted on a single 88- by 108-inch pallet. Typical installation setup time by two men is 30 minutes.

HEAVY-DUTY PORTABLE SCALES.—This system is designed to provide weight only. Wheeled vehicles and cargo may also be weighed on these scales. The complete system is portable and completely self-contained. Platform size is small, but it may be increased by connecting two scales with a factory provided channel. Because of the small platforms, you must exercise care when using this system. Typical installation setup time by two men is 10 minutes.

STATIONARY PIT-TYPE SCALES.—Most of the large scales are of the stationary-beam and lever-balance type. See figure 1-18. These scales are commonly flush floor installations, although some are used as surface-type portable scales. The flush floor installation generally is in a permanent location, and the aircraft must be taken to it. However, some flush floor scales have the capability to be removed from their installations, when necessary, and taken to the aircraft. These scales are usually expensive and normally require a special building or hangar.

Weighing with calibrated scales is the only sure method of obtaining an accurate basic weight and center of gravity location on an aircraft. The large stationary pit-type scales must be calibrated or certified correct at least once every 12 months. Heavy-duty portable scales and MEWS scales must be calibrated at least once every 6 months.

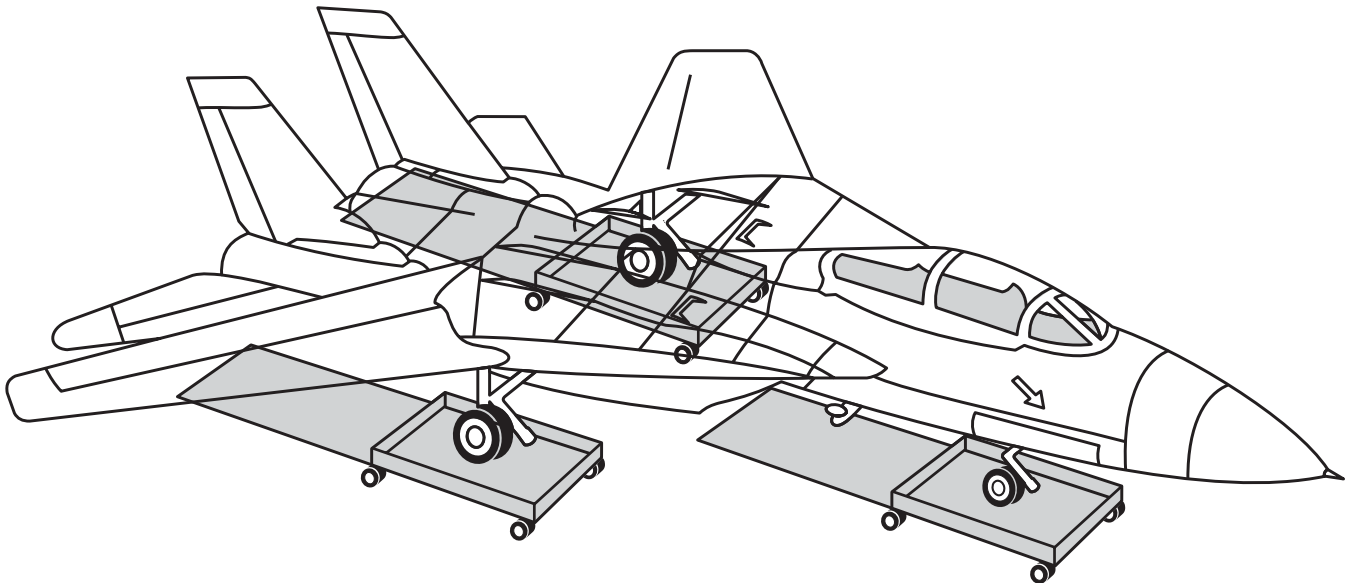

AMf01017

Figure 1-17.—Mobile Electronic Weighing System (MEWS).

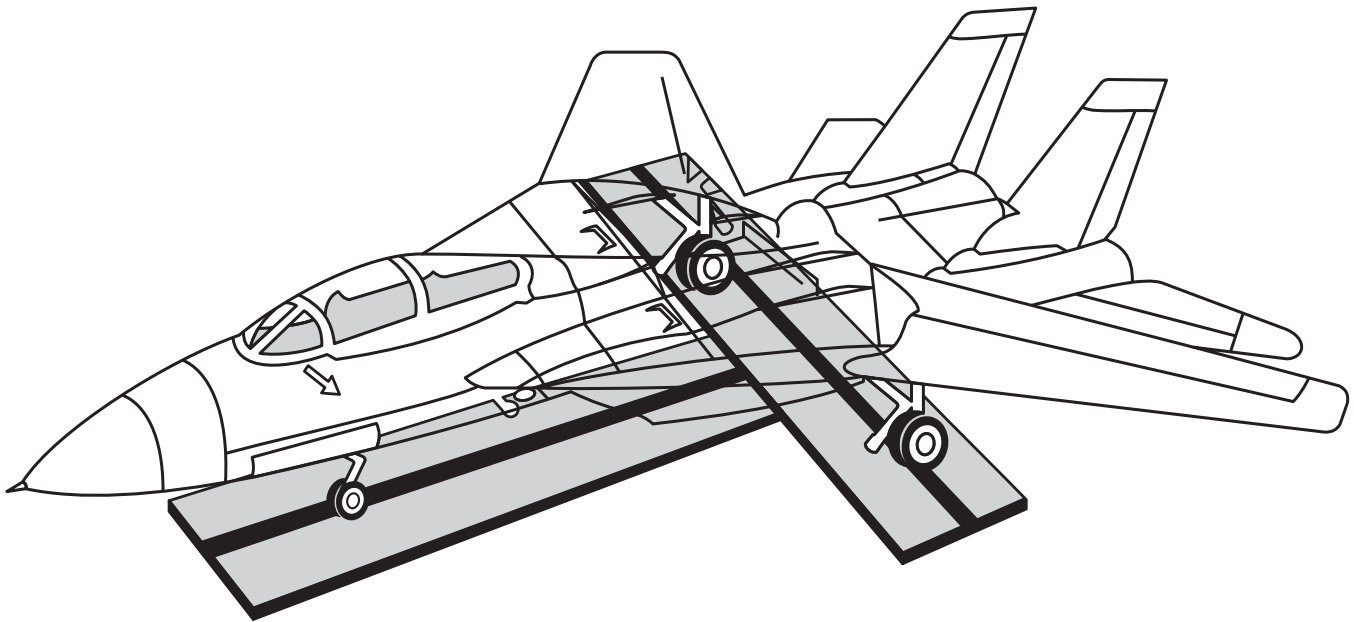

AMf01018

Figure 1-18.—Stationary pit-type scales.

Weighing Accessory Kit

It may be necessary to prepare special devices that will aid in taking measurements and leveling specific types of aircraft. To measure such data as lengths, angles, and densities, weight and balance personnel require accessories, such as levels, plumb bobs, measuring tapes, chalk lines, and hydrometers. Some types of aircraft require special equipment. The equipment will be assembled into a specific type of aircraft kit.

SPIRIT LEVEL.—At least one spirit level is required for leveling most aircraft. Two levels are generally recommended. Use one 24-inch level for spanning distances between leveling lugs. Use a 6-inch level for use in places where sufficient space is not available for seating a 24-inch level. The levels should be a machinists' bench type of first-class quality.

LEVELING BARS.—Several leveling bars of varying lengths are needed for spanning the distances between leveling lugs. One set of bars usually comes with the weighing kit, which is normally maintained by each Naval Aviation Depot (NADEP).

PLUMB BOBS.—Plumb bobs are used to project points on the aircraft onto the floor for measuring dimensions in a level plane. Each plumb bob should have a slot in the head so that excess string can be wound around the neck. Plumb bobs are normally included in the weighing kit.

STEEL TAPES.—Use a steel tape 600 inches in length and graduated in inches and tenths of inches. All weighing dimensions must be read to one-tenth of an inch, and are frequently read to one-hundredth of an inch. Using this type of tape reduces the possibility of errors associated with converting common fractions to decimals. These tapes are usually found in the weighing kit.

CHALK LINE.—This is a string that is covered with chalk and used to mark a straight chalked line on the hangar floor. It is used between the vertical projections of specified jig points. The string should be sturdy and hard finished. It usually accompanies the weighing kit.

HYDROMETERS.—Use a hydrometer with a calibration range from 5.5 to 7.0 pounds per US gallon for determining the density of fuel. A transparent container for holding fuel samples, a pipette at least 12 inches long, or some other similar device for withdrawing samples from the tank, is necessary for use with the hydrometer. You must take care not to damage the glassware. To determine the density of a fuel sample, you should carefully place the hydrometer into the fluid within the transparent container. The hydrometer must not touch the container when you are reading the density, and you should take the reading at the lowest fuel point.

NOTE: The hydrometer is used to determine fuel density for full fuel weighing. Since full fuel weighing

is permitted only with specific NAVAIR (AIR-5222) approval, a hydrometer will not normally be a part of the weighing kit.

Weighing Procedure

A defined and orderly aircraft weighing procedure lessens the chance of omitting necessary dimensional or scale readings. The choice of alternative procedures depends upon the equipment at hand and on the circumstances under which the aircraft is to be weighed. Always refer to the particular aircraft's Chart E loading data. Use the following procedures to accomplish proper aircraft weighing.

- Thoroughly clean the aircraft inside and out, removing dirt, grease, and moisture. Allow the aircraft sufficient time to dry before weighing. Assemble the required weighing equipment, including scales, hoisting equipment, jacks, cribbing, leveling bars, level, measuring tape, plumb bobs, and chalk line. Drain fuel in accordance with the aircraft's Chart E or other applicable instructions. This draining is generally done in the aircraft's normal ground attitude. Aircraft with internal foam in their fuel tanks pose special problems, since some fuel is always retained in the foam. In this case, unless specific instructions are in the aircraft's Chart E, draining should be terminated when the fuel flow becomes discontinuous or starts to drip.

- Remove load items, such as bombs, ammunition, cargo, crew members, and equipment not having a fixed position in the aircraft. They are not listed as a part of the basic weight on the Chart A, Basic Weight Checklist Record, DD Form 365A (DD Form 365-1), and should not be in the aircraft when weighed. Check all reservoirs and tanks for liquids, such as drinking and washing water, hydraulic fluid, anti-icing fluid, cooling fluids, and liquid oxygen. Reservoirs and tanks should be empty or filled to normal capacity before weighing. Oil tanks are to be filled to normal capacity before weighing. Calculations on the Aircraft Weighing Record, DD Form 365-2, will resolve differences between the as-weighed condition and the basic-weight condition. All waste tanks must be empty.

- Move the aircraft to the area where it will be weighed. Do not set the aircraft brakes, for this may induce side loads and thrust loads on the scales, which, in turn, may give erroneous weighing results. The aircraft must be weighed in a closed hangar or building with no blowers or ventilating system blowing air upon the aircraft.

- Conduct a Chart A inventory of equipment actually installed in the aircraft. This inventory will be accomplished under the supervision of the qualified weight and balance technician (qualified by graduation from one of the NADEP weight and balance schools) responsible for weighing aircraft. A basic weight without the correct associate inventory is of no value.

- Correct the Chart C, Basic Weight and Balance Record, DD Form 365-3, based upon the Chart A inventory. Use such data as the current Chart C basic weight, the Chart A inventory, and the Chart E loading data to estimate an "as weighed" weight and moment. To the current basic weight, add the oil (if not part of current basic weight) and "items weighed but not part of the current basic weight," and subtract the "items in the basic weight but not in the aircraft."

- When weighing an aircraft with platform scales, such as the MEWS or stationary scales, ensure that all scales are within their calibration date. If the scales are portable, set up the scales and level them. Attach the cables from the platform to the readout. Warm up electronic scales for a minimum of 20 minutes. Zero the scales. Level the aircraft by servicing. Most aircraft can be leveled in this manner. See NAVAIR 01-1B-40 and NAVAIR 01-1B-50 for aircraft where this procedure is not required or desired.

- Tow the aircraft onto the scales. Do not apply the aircraft's brakes, because they may bind the scales; this would require rezeroing of the scales. Recheck the aircraft level. Read the scales and make dimensional measurements per Chart E instructions and NAVAIR 01-1B-50.

- Make the applicable DD Form 365-2 entries and verify the weighing results. If a large discrepancy is noted, check to see where the error could have occurred. If the source of the error is not found, reweigh aircraft by removing and replacing the aircraft on the scales.

- Remove the aircraft from the scales. If the scale does not return to zero after 10 minutes, reweigh the aircraft. Be sure that the brakes are not used or applied. Determine the tare per the appropriate scale instructions. Tare is the weight of equipment necessary for weighing the aircraft. Tare includes items such as shocks, blocks, slings, and jacks. These items are included in the scale reading, but are not part of the aircraft weight. Tare may also include a scale correction factor. A scale correction factor is used to modify scale readings because of inherent inaccuracies of the scale. If the scale correction factor is larger than the scale

calibrated accuracy, the scale should be repaired. Enter the tare on the Aircraft Weighing Record, DD Form 365-2. Stow the equipment.

All aircraft must be weighed and balanced upon completion of standard depot-level maintenance (SDLM). Aircraft should also be weighed and balanced under the following conditions:

1. When service changes, modifications, or repairs are accomplished and calculated, or actual weight and moment data for these changes are not available
2. When recorded weight and balance data is suspected of being in error
3. When unsatisfactory flight characteristics are reported by the pilot that cannot be traced to a flight control system malfunction or improper aircraft loading
4. When the "Weight and Data" handbook has been lost or damaged

BALANCE

An aircraft is said to be in balance, or balanced, when all weight items in, on, or of the aircraft are distributed so that the longitudinal center of gravity (cg) of the aircraft lies within a predetermined cg range. This range is defined by the most forward and aft permissible cg locations, which are called the forward and aft cg limits, respectively. To determine if an aircraft is balanced, the aircraft cg must be calculated and compared to the forward and aft cg limits for that particular configuration and gross weight.

- Q1-28. What characteristics of an aircraft are directly dependent upon its weight and balance condition?*
- Q1-29. What technical manual covers weight and balance?*
- Q1-30. What is the standard method used by the Navy for weighing aircraft?*
- Q1-31. How often must heavy-duty portable scales and MEWS scales be calibrated?*
- Q1-32. What is the minimum time required for an electronic scale to warm up?*
- Q1-33. What actions must be accomplished if the Weight and Data Handbook is lost?*

AIRCRAFT HOISTING SLINGS

LEARNING OBJECTIVE: Recognize the different types of aircraft hoisting slings.

Identify the hoisting requirements for naval aircraft.

There are three main conditions that might require you to hoist an aircraft or its components. They are aircraft mechanical problems, ship mechanical problems, and aircraft mishap afloat or ashore. Aircraft lifting slings are specialized items of support equipment whose function is to aid in the hoisting of aircraft and aircraft components. Each airframe has structural lifting points for the attachment of a sling designed to lift that aircraft or aircraft subassembly. Slings are used to hoist aircraft from the pier to carrier deck, clear crash-damaged aircraft, and to remove and install engines and other components during maintenance operations. In general, slings are hand portable and attach to a single suspension hook of a crane or other hoisting equipment.

LIFTING SLINGS IDENTIFICATION

Aircraft lifting slings are constructed in accordance with Military Specification MIL-S-5944, and can be classified under four types of construction or combinations of type. The four types are the wire rope, the fabric or webbing type, the structural steel or aluminum type, and the chain.

Wire Rope

Slings of this type employ wire rope or cable. The wire rope sling is the most common type, and it combines high strength, ease of manufacture, and a great deal of flexibility for compact storage. There are two basic types of wire rope slings. The simplest is a multi-legged wire rope sling with an apex-lifting link. The other is one built with structural steel or aluminum in combination with wire rope supports. See figure 1-19.

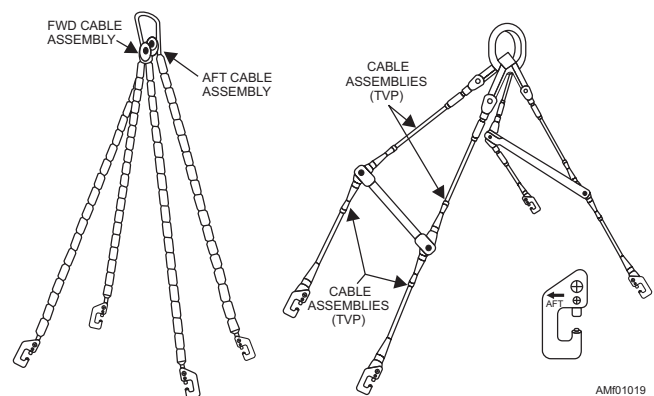
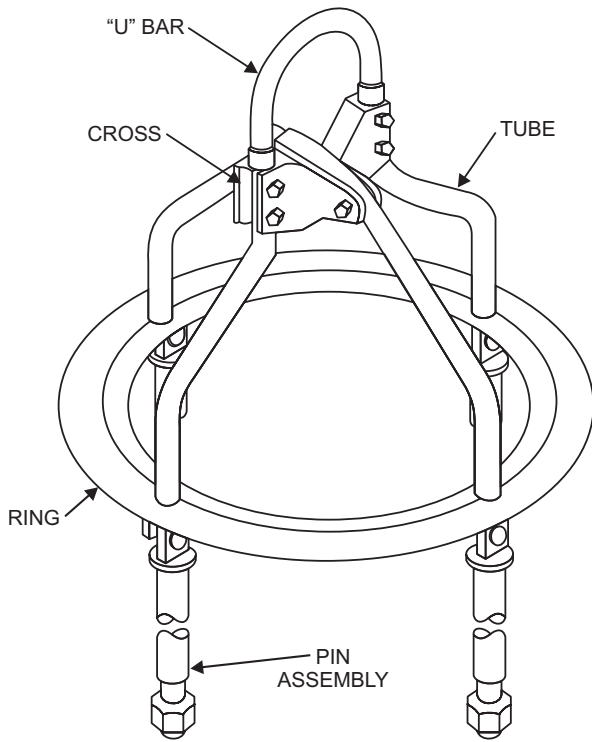

Figure 1-19.—Wire rope slings.



AMF01020

Figure 1-20.—Typical steel/aluminum sling.

Fabric or Webbing

Fabric or webbing type slings are generally reserved for lifting lightweight objects, or applications

where contact between wire rope and the component being lifted could result in damage.

Structural Steel or Aluminum

Slings of this type are constructed with plates, tubing, I-beams, and other structural shapes, and they do not contain flexible components. See figure 1-20. Structural steel and aluminum slings are generally compact in size, and they are often used for lifting aircraft subassemblies.

Chains

Chains are generally used in combination with one of the other types of sling construction. See figure 1-21. A chain with a chain adjuster provides a simplified method of shifting the lifting point on a sling to match the component's center of gravity under a variety of hoisting configurations.

LIFTING SLING MAINTENANCE

Load-bearing cables, chains, straps, and other structural members of hoisting and restraining devices are subject to wear and deterioration. It is necessary that these components be inspected and lubricated periodically to ensure safe and proper operation. On initial receipt of equipment or return of equipment from

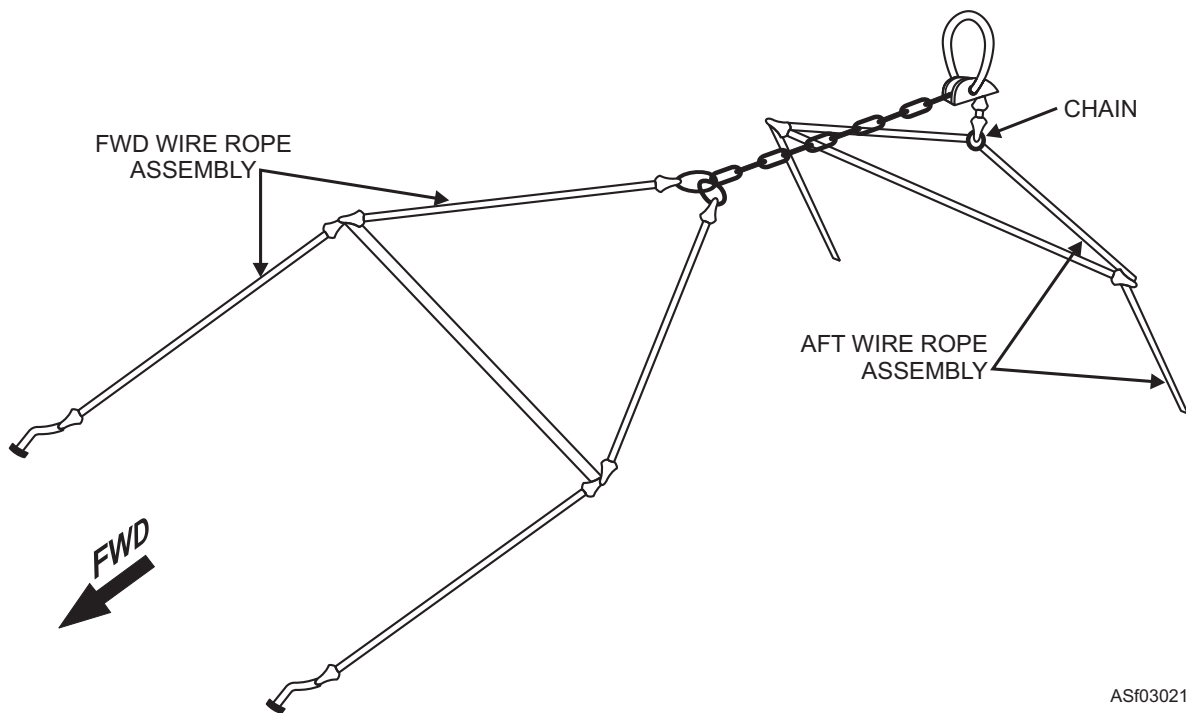

ASf03021

Figure 1-21.—Combination wire rope and chain sling.

depot-level repair, the Aircraft Intermediate Maintenance Department (AIMD) will perform a visual inspection of the hardware for missing or damaged components. Upon completion of the inspection, the AIMD will tag all equipment in accordance with the *Inspection and Proofload Testing of Lifting Slings and Restraining Devices for Aircraft and Related Components* manual, NAVAIR 17-1-114.

Preinstallation Inspection

Before each use, or once a month as in the case of emergency handling slings, a complete visual inspection of the wire rope, fabric or webbing, structural steel or aluminum, and chain slings must be performed.

WARNING

Slings that fail to pass the inspections, or slings suspected of having been used during hoisting operations beyond the rated capacity of the sling, will not be used under any circumstance. Unserviceable slings are forwarded to the applicable Aircraft Intermediate Maintenance Department for further analysis and disposition.

WIRE ROPE.—To assist in understanding various inspection criteria for wire rope, a basic knowledge of wire rope construction is required. Each individual cylindrical steel rod or thread is known as a

wire. Each group of wires twisted together forms a strand. A group of strands twisted around a central core is known as a wire rope or cable. A filler wire is a wire used to fill the voids between wires in a strand and between strands in a wire rope. They provide stability to the shape of the strand or wire rope with little strength contribution. Wire rope construction is designated by two numbers. The first being the number of strands in a cable, and the second being the number of wires in each strand. The following wire rope constructions are used in the fabrication of aircraft hoisting slings. See figure 1-22.

A 7×7 wire rope consists of six strands of seven wires each twisted around a single core strand of seven wires. The 7×7 construction is used on wire ropes measuring 1/16 and 3/32 inch in diameter. Similarly, 7×19 wire rope is constructed with six strands of 19 wires each twisted about a core strand also containing 19 wires. The 7×19 wire ropes measure from 1/8 to 3/8 inch in diameter. A 6×19 independent wire rope core (IWRC) cable consists of six strands, each containing 19 wires twisted about a core that is of a 7×7 construction. The 6×19 (IWRC) wire rope measures from 7/16 to 1 1/2 inches in diameter. During the inspection of a wire rope, the measurements of the diameter and lay length (pitch length) often lead to confusion. The diameter and lay length are defined as follows:

1. Diameter. The diameter of a wire rope is the diameter of a circle circumscribed around the cable

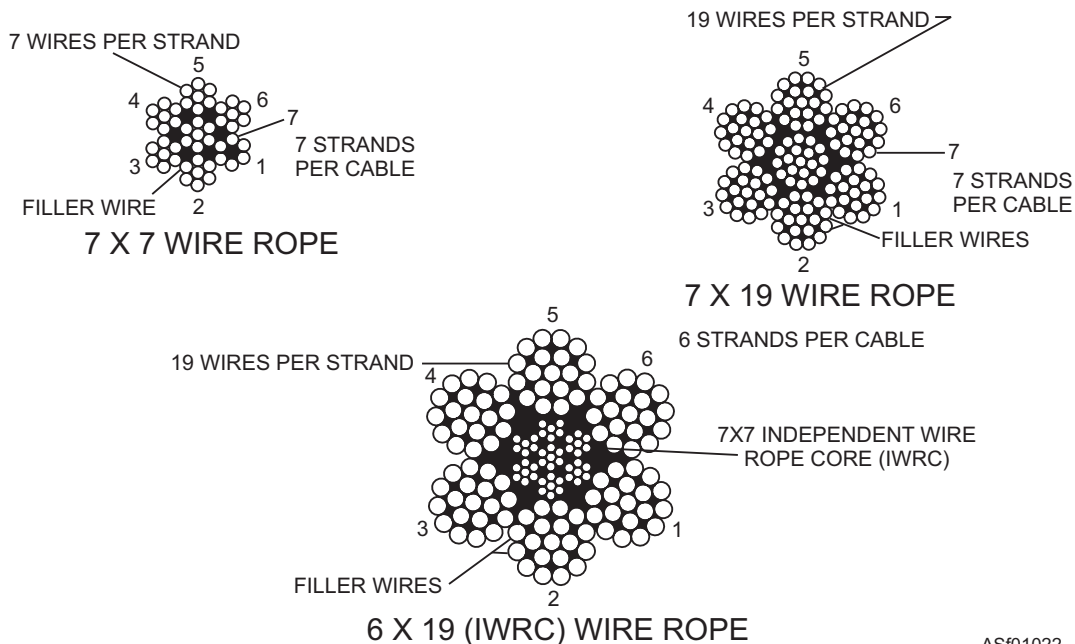

Figure 1-22.—Cross sections of wire rope.

ASf01022

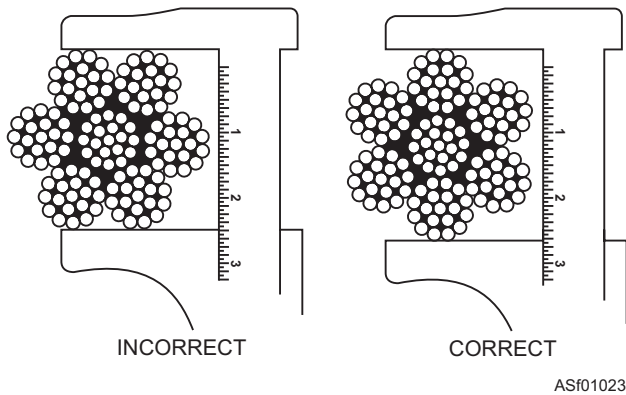

Figure 1-23.—Measuring the diameter of a wire rope.

cross section. Figure 1-23 shows the proper method of measuring the diameter of a wire rope.

2. Lay Length. The distance, parallel to the axis of the cable, in which a strand makes one complete turn about that axis is known as the lay length or pitch length. Figure 1-24 shows the lay length of a wire rope.

Wire rope cables are visually inspected for knots, fraying, stretching, abrasions, severe corrosion, and other signs of failure. Of particular importance is the detection of a cable in which a kink has been pulled through in order to straighten the cable. The resultant deformation is known as a bird cage. See figure 1-25. In such a case, the sling should be discarded.

The presence of one or more broken wires in one rope lay length or one or more broken wires near an attached fitting is cause for replacement. If a broken wire is the result of corrosion or if the cable is excessively corroded, the cable must not be used regardless of the number of broken wires. Replace cables exhibiting rust and development of broken wires in the vicinity of attached fittings. Replace wire ropes evidencing bulges, core protrusions, or excessive reductions in rope diameter.

FABRIC OR WEBBING.—Fabric or webbing straps must be visually inspected for cuts, holes, severe abrasions, mildew, dry rot, broken stitches, frays and deterioration. Deterioration may be caused by contact with foreign materials, such as oil, fuel, solvents, caustic fluids, dirt, and lye. The existence of any of the above conditions renders the sling unserviceable. Twists, knots, and similar distortions must be corrected before use.

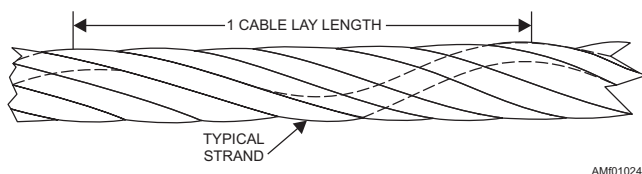

Figure 1-24.—Cable lay length.

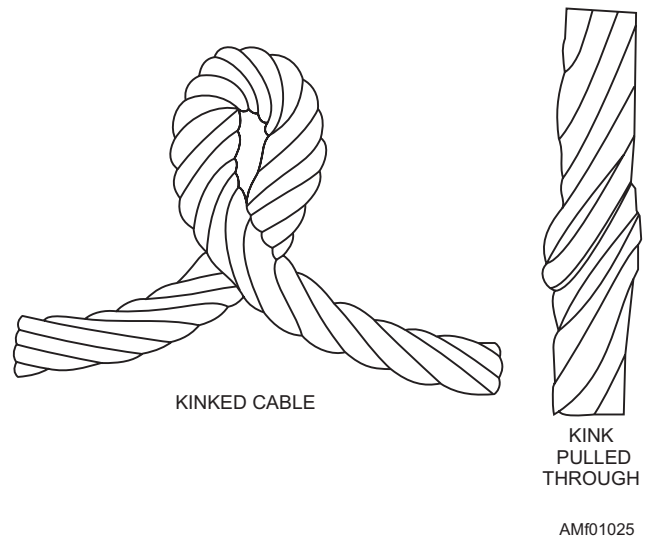

Figure 1-25.—Cable damage resulting from a pulled-through kink.

STRUCTURAL STEEL OR ALUMINUM.—Visually inspect all terminals, shackles, lugs, and structural members for misalignment, wear, corrosion, deformation, loosening, slippage, fractures, open welds, pitting, and gouges. Examine slides and screw adjusters for burrs, misalignment, and ease of operation. Inspect sling attachment bolts and pins for elongation, wear, deformed threads, and other signs of imminent failure.

CHAINS.—Chains will be visually inspected for stretched links, wear, gouges, open welds, fractures, kinks, knots, and corrosion. Chain attachment fittings and adjusters will be examined for security, wear, corrosion and deformation.

Lubrication, Transportation, and Storage Requirements

Examine and lubricate all slings once a month in accordance with NAVAIR 17-1-114. When transporting slings, they will be carried at all times. Dragging slings over floors, runways, decks, and obstructions can cut or severely abrade the material. This malpractice results in an unserviceable sling. Whenever possible, slings should be stored indoors in a clean, dry, well-ventilated area so as to be protected from moisture, salt atmosphere, and acids of all types. In addition, slings constructed with nylon or other fabric materials will be stored in such a way as to prevent contact with sharp objects, high temperatures, and sunlight. Fabric materials deteriorate rapidly from prolonged exposure to sunlight or excessive heat—severely reducing strength and service life. Where practicable, slings will be securely fastened to overhead storage racks to prevent accidental damage. Avoid laying slings on ash or concrete floors.

Hoisting Restrictions

There are many restrictions to hoisting for each type of aircraft. Most hoisting restrictions are the same as for jacking aircraft. If you violate any of these restrictions, there is a good chance that you will have an accident, damage the aircraft, or injure someone. The restrictions generally concern aircraft gross weight and configuration. Some of the considerations are access (stress) panels on or off, external stores on or off, and wings, folded or spread.

There are many factors that can affect the safety of the aircraft and personnel during hoisting operation. For details on restrictions and for the proper installation of any sling, consult the applicable MIM. Don't forget that many squadrons have their own local standing instructions for hoisting aircraft that contain additional safety precautions and restrictions. You must know these precautions and restrictions as well.

Prior to carrier operation, aircraft hoist points are inspected for serviceability and easy access in an emergency. For details on how to accomplish this inspection on your aircraft, consult the applicable MIM.

- Q1-34. What are the four types of aircraft slings?*
- Q1-35. What is the most common type of aircraft lifting sling used today?*
- Q1-36. What types of slings do not contain flexible components?*
- Q1-37. What manual covers load testing and inspection information for aircraft slings?*
- Q1-38. How often should inspection and lubrication of aircraft slings be accomplished?*

AIRCRAFT JACKING

LEARNING OBJECTIVE: Recognize the procedures for the safe raising and lowering of aircraft by the proper use of aircraft jacks. Identify the various types of jacks presently found in the naval inventory.

The following text will familiarize you with the various types of jacks, their use, and general safety procedures. You will become familiar with jack identification, preoperational inspections, and jacking procedures.

JACK IDENTIFICATION

All aircraft hydraulic jacks are either axle or airframe (tripod) jacks. These jacks use standard, authorized aircraft hydraulic fluid. They have a safety bypass valve that prevents damage when a load in

excess of 10 percent over the rated capacity is applied. For example, the safety valve on a 10-ton jack will bypass fluid at 11 tons of pressure.

Axle Jacks

Use axle jacks for raising one main landing gear or the nose gear of an aircraft for maintenance of tires, wheels, and struts. There are four different types of axle jacks and many different sizes (lifting capacity in tons). The smaller hydraulic axle jacks are normally squadron or unit permanent custody equipment. That means your outfit is responsible for making sure the jacks are load tested at the support equipment (SE) division of the Aircraft Intermediate Maintenance Department (AIMD) before being put into service, and annually thereafter. Special inspections include 13-week inspections at AIMD SE, but a load test is not required every 13 weeks. A record of maintenance, inspections, technical directives, and load testing is kept on OPNAV Form 4790/51.

All model designations for axle jacks begin with the letter A, for axle, such as A10-1HC. The number following the A shows the jack capacity in tons, such as 10 for a 10-ton jack. This is followed by a dash (-) and the specific jack identification number. Then comes two letters that show the type of jack (HC = hand carried, HS = horseshoe, TB = T-bar, and OR = outrigger). The four types of axle jacks are discussed in the following text.

HAND CARRIED.—These axle jacks (fig. 1-26) are portable, self-contained units, with single or double

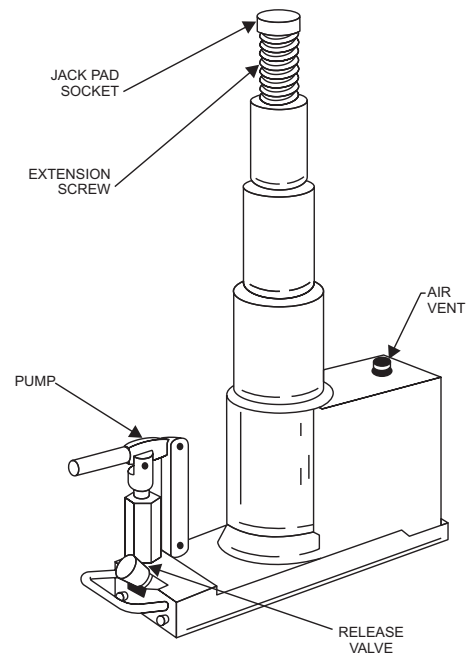

AM01026

Figure 1-26.—Hand carried axle jack.

manually operated pumps. They have carrying handles, pump handles, reservoir vent valves, release valves, and safety valves. The different model sizes vary from 4 3/4 inches to 9 inches high (closed). Their weights vary from 26 to 120 pounds.

HORSESHOE.—Horseshoe axle (fig. 1-27) or crocodile jacks consist of a lifting arm supported by two hydraulic cylinders. The cylinders move up over the stationary pistons when the manual pump operates. The A25-1HS is a large jack, 5 feet long, 5 feet 8 inches wide, standing 2 feet 1 3/4 inches high, and weighing 900 pounds.

T-BAR.—The T-Bar or alligator axle jack (fig. 1-28) is mounted within a T-shaped frame. A manual pressure pump and a speed pump mount on opposite sides of the towbar end of the frame. The jack weighs 235 pounds and is 4 feet 2 1/2 inches long, 2 feet 3 inches wide, and 10 inches high (closed).

OUTRIGGER.—This cantilever axle jack (fig. 1-29) is a very large and heavy jack. It weighs 2,190 pounds and is 7 feet 3 inches long, 6 feet 8 inches wide, and 2 feet 3 inches high. A double (two-speed) pump mounts on the left-hand side of the frame to operate the hydraulic cylinder.

Airframe (Tripod) Jacks

Use airframe (tripod) jacks for lifting the entire aircraft off the ground or deck. Airframe jacks are commonly called tripod jacks. You may hear them called wing, nose, fuselage, or tail jacks. These names

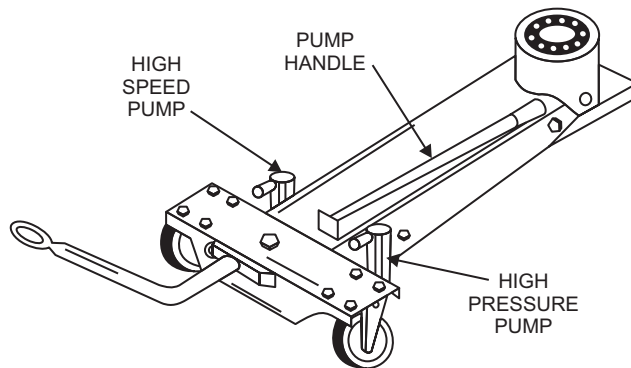

ASf01028

Figure 1-28.—T-Bar axle jack.

come from the jack placement on the aircraft. The points for jacking vary with the type of aircraft, and can be found in the MIM for each type of aircraft.

There are two different types of tripod jacks—fixed height and variable height. Both are mobile, self-contained, hydraulically operated units. They consist of three basic assemblies. These assemblies are the hydraulic cylinder, the tubular steel wheel tripod leg structure, and the hydraulic pump. The main difference between the two types is that the tripod structure on a variable height jack can be adjusted to different heights by adding leg extensions.

All model designations for tripod jacks begin with the letter *T*, for Tripod, such as T10-2FL or T20-1VH5. The number following the *T* indicates the jack capacity in tons, such as 10 for a 10-ton jack. This is followed by a dash (-) and the specific jack identification number. Then comes two letters indicating the type of tripod jack (*FH* = fixed height, or *VH* = variable height). The number that follows the *VH* for variable height jacks indicates the number of leg extension kits available for that jack. Figure 1-30 shows a T20-1VH5 jack with

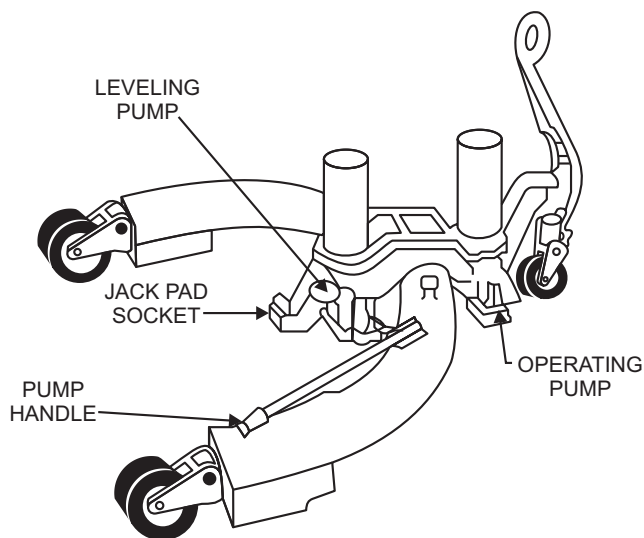

AMf01027

Figure 1-27.—Horseshoe axle jack.

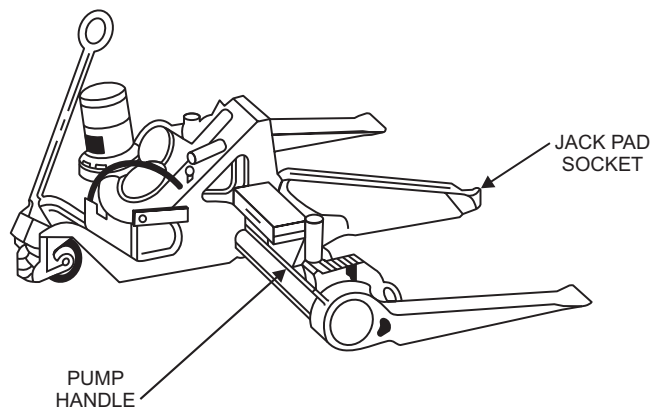

ASf01029

Figure 1-29.—Outrigger axle jack.

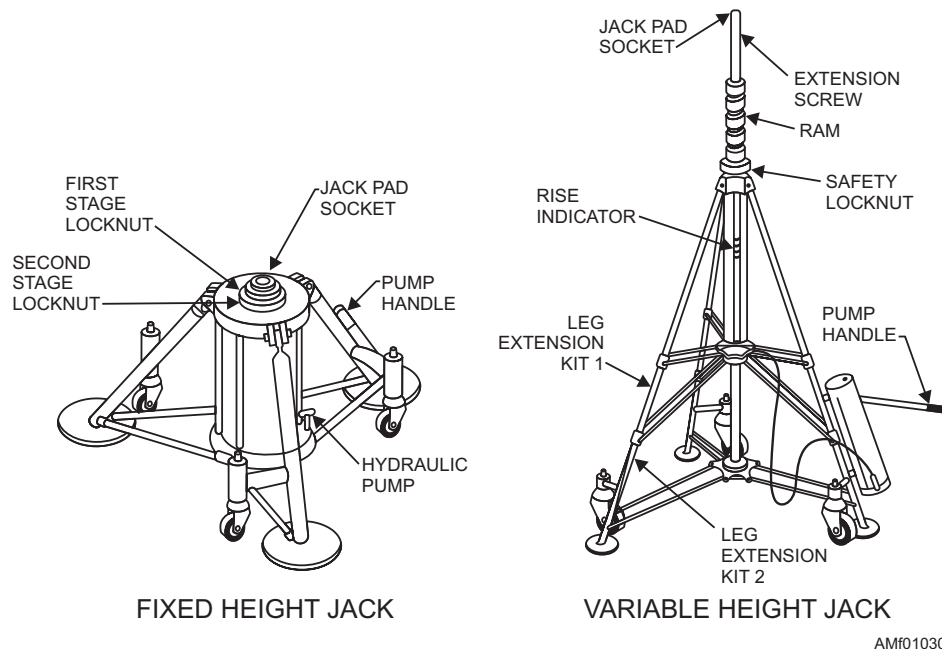

Figure 1-30.—Airframe (tripod) jacks.

only two of five extension leg kits installed. Each leg extension kit increases the effective height of the basic jack by 18 inches. The airframe tripod jacks weight varies from 275 pounds to 837 pounds.

Several safety features are built into the tripod jacks. A locknut (also called a ring or collar) on the ram mechanically locks the ram in position. The locknut prevents the ram from settling in the event of hydraulic failure or inadvertent lowering. A safety bypass valve in the system bypasses fluid from the pump or ram when excessive pressure is built up.

Airframe (tripod) jacks are normally checked out from the SE division (AIMD) when needed. Since transporting these heavy and cumbersome jacks is a problem, they often remain in custody of an organization for a prolonged period of time. The organization must be responsible for their care and cleanliness during periods when not in use. As with axle jacks, these jacks need to be load tested prior to being placed in service and annually thereafter. Special inspections are performed every 13 weeks at AIMD SE and recorded on the OPNAV Form 4790/51.

The MIM will tell you what type of aircraft jack to use at each position. When deployed, you may not be able to get the jacks that are called for in the MIM. You will have to refer to the *Index and Application Tables for Aircraft Jacks*, NAVAIR 19-70-46. It was prepared under the direction of the Commander, Naval Air System Command, by the Naval Air Engineering

Center. It contains a list of approved prime and alternate jacks for all Navy and Marine aircraft.

PREOPERATIONAL INSPECTION

The same basic safety precautions apply to all jacks. Conduct a good preoperational inspection before you use it. NAVAIR 19-600-135-6-1 is the general preop Maintenance Requirements Card (MRC) for all jacks. Make sure that the jack has been load tested within the last 13 weeks. Next, if the jack is dirty, take the time to wipe it down. You can't see cracks or broken welds under dirt. If the jack is covered with hydraulic fluid, you can suspect it may be leaking. Inspect it more closely.

Check the reservoir; it should be full with the jack ram fully collapsed. If the reservoir is low, you can suspect a leak somewhere. Fill the reservoir with clean, fresh, hydraulic fluid. Check the filler plug vent valve to make sure it is not clogged. If the plug is blocked, you may get an air lock, and the jack may not operate correctly. You could also get a pressure buildup in the reservoir and a possible rupture. Check the pump handle for bends and the pump rocker arm and link for elongated or out-of-round holes. These are signs that the jack may have been overloaded, and that the safety bypass valve is malfunctioning.

With the filler plug air vent valve open and the release valve closed, pump up the ram and check for leaks and full extension. When the ram reaches full

extension, you will feel the pumping pressure increase. Don't continue to pump or you may damage the internal ram stops because there is no load on the jack.

Lower the ram and screw out the extension screw, but don't forcibly overextend it past the internal stops. Check to see that it is clean and oiled. If it is dirty, wipe it clean and coat it with a light film of MIL-L-7870 oil.

On jacks equipped with wheels, check the wheels and springs suspension assemblies to make sure they are in good condition. Towing or dragging these jacks around with broken wheels will damage the frame or reservoir.

Since many leaks in jacks will only appear when the jack is under a load, be sure to watch for leaks when you are jacking the aircraft. If you find a leak, or other defects, during the preoperational inspection, do not continue to use the jack. Down or red line it, tag it as bad, report it, and turn it into the SE division (AIMD) for repairs. Don't leave a defective jack where someone else may use it.

HANDLING AND MOVEMENT

Handling airframe jacks can be hazardous. The jacks are heavy—anywhere from 110 to 900 pounds—and the wheels are free swiveling and small. Directional stability is poor, and pushing one into position around an aircraft is no simple chore. Trying to move or position a tripod jack by yourself is hazardous. If the jack is dirty and covered with grease or fluid, it's even more hazardous. The jack footplates and wheels at the base of the tripod stick out, and are notorious "foot-crunchers" and "shin-knockers." It's not hard to damage an aircraft tire, wheel brake assembly, hydraulic lines, landing gear door, or any other part of an aircraft if you are not careful and ram it with a jack.

Movement of jacks aboard ship when there is any pitch or roll of the deck is extremely hazardous. Even with a calm sea, a smart turn into the wind by the ship while you're moving an airframe jack can be disastrous. Movement of jacks from hangar to hangar, through hangar bays, and across hangar tracks and ramp seams can easily damage a jack and put it out of commission—just when you need it!

Transportation of jacks over longer distances ashore, such as from the SE pool to a hangar on the other side of the field, can be a real problem. If your SE division (AIMD) has locally fabricated a special "jack

transporter" trailer, you're in luck. If any other type trailer, truck, or flatbed is used, you must have sufficient manpower available to safely get the jacks on and off the vehicle. Jacks are heavy and cumbersome to handle. Loading and unloading is hazardous even when you have enough people. Usually, a locally fabricated sling and some sort of hoist is necessary. Forklifts should never be used to handle or lift jacks. The tripod cross braces are not strong enough, and you will damage the jack. The chances of dropping it are also high. Do NOT use forklifts to handle jacks.

The wheels on a tripod jack are not made for towing the jack. They are small, allow only a couple of inches of clearance, and are spring loaded. Bouncing over uneven surfaces will usually cause the jack footplates to hit the ground, and that can spin the jack around, tip it over, or damage the tripod structure. Airframe jacks don't have towbars, the wheels can't be locked in position so they track, and there are no brakes. NEVER try to tow airframe jacks.

Free swiveling casters and no brakes also mean that jacks can move by themselves if not properly secured. A loose, 900-pound tripod jack on a pitching hangar deck could be disastrous. Jacks can also be moved by jet or prop blast. Therefore, any jack that isn't tied down can be a hazard. Since there are no tie-down rings on the jacks, you must take care as to how you attach the tie-down chains or ropes to prevent damage to the jack. This is particularly true aboard ship where the jacks are likely to be "working" against the tie-downs in rough seas.

General Hazards

The extension screws on jacks have a maximum extension range. This range is stenciled on the jack. An internal stop prevents overextending the screw. If you forcibly overextend the screw, which isn't hard to do, you not only damage the internal stop mechanism, but also make the jack unsafe and hazardous to use. An overextended screw is very likely to bend or break off from any side motion.

The extension screw on a jack is equipped with a jack pad socket. The aircraft jack pad fits into this socket and into a fitting or socket in the aircraft. The sockets and pads are designed to take vertical loads but not much horizontal pressure. The pads can shear or slip from either the jack or aircraft socket if enough side load is applied.

Side loads normally result when the jacks are not raised at the same rate. This causes the aircraft to tilt or pitch. When that happens, the distance between the jacking points becomes closer in the ground plane—like the ends of a ruler will cover less distance across a desk top as you raise one end. With the weight of the aircraft holding the jacks in one place, that "shrink" in distance between the jack points creates a tremendous side load on the jacks, and eventually they will break or slip. The same thing happens if all the jacks aren't lowered at the same rate to keep the aircraft level or at the same attitude it was in when jacking started.

Lowering the jack can be very hazardous. The rate of descent of a jack depends on how far the release valve is opened. Control can be very tricky when you're trying to coordinate three jacks at once. Usually, it takes only a small amount of rotation on the valve to get a fast rate of descent. If you tightened the valve hard before jacking, it will take force to open it. That extra force can cause you to open the valve more than you want, so be very careful. The valves may vary in different jacks, so get an idea of how your release valve reacts during the preop check. But remember it comes down a lot quicker with a 30-ton load than with a 5-ton load.

There is a safeguard to prevent you from lowering the jack too fast—the safety locknut. The safety locknuts on jacks are a very important safeguard in preventing the aircraft from falling off the jacks in the event of jack failure. However, using them during raising, and particularly during lowering operations, is hazardous to your hands and fingers. To be effective, the locknut must be kept about one-half thread above the top surface of the jack (top of ram cylinder or second ram, depending upon the model jack). It is important to carefully keep your fingers and hands clear of the area between the locknut and cylinder head so they won't be pinched or crushed. This will be easier for you to do while you are raising the jack and rotating the locknut down. Variable height jack rams have spiral grooves, which allow the locknut to rotate down the ram by its own weight. However, this means that when you're lowering the jack, the locknut must be held up as you rotate it up the ram. This makes it more dangerous. Depending upon the height of the jack, it normally takes two people to operate the jack and the safety nut. Do NOT try to do it by yourself.

Jacking Restrictions

There are many restrictions to jacking for each type aircraft. If you violate any of these restrictions, there is a good chance that you will have an accident, damage the aircraft, or injure someone. The restrictions generally concern aircraft gross weight and configuration. Some of the considerations are fuel dispersion in fuselage and wing tanks, engines in or out, and tail hook up or down.

Details on restrictions and procedures are in the MIMs, and you must know them and follow them exactly. If you don't, you will be in trouble. Don't forget that many squadrons will have their own local standing instructions for jacking aircraft, which contain additional safety precautions and restrictions. You must know these precautions and restrictions also.

JACKING PROCEDURES

The jacking procedures vary for each aircraft type and configuration. The procedures that follow are examples of what you could encounter. Fairly exacting steps are given to provide clarity. Remember, these steps are from representative type aircraft, and are not necessarily accurate for all. When actually jacking aircraft, you must follow the exact procedures described in the MIMs.

The location of the aircraft will determine what you need for equipment. Jacking procedures on a ship require tie-down procedures to prevent aircraft from shifting on jacks. When tie-down chains are to be used, position them in accordance with the MIM, so as not to interfere with the landing gear during the drop check of the gear. Jacking procedures on land do not require tie-downs, except in high-wind conditions.

Aboard ship, squadron maintenance controls will request, through the carrier air group (CAG), permission to place an aircraft on jacks. Check your MIM for jacking restrictions, warnings, and cautions. Obtain the support equipment required by the MIM, ensuring all preoperational inspections have been completed. Make sure that all protective covers and ground safety devices are installed, as required by the MIM. The surrounding area around the aircraft must be roped off during the entire aircraft jacking operation,

and signs posted stating "**DANGER: AIRCRAFT ON JACKS.**" The area below and around the aircraft must be cleared of all equipment not required for the jacking operation. Install jack adapters, aircraft mooring adapters, and tie-down chains as required by the MIM. Figure 1-31 shows an example of carrier tie-down for aircraft jacking. Position and extend wing and nose jacks until seated on wing jack and tie-down adapters.

NOTE: Some aircraft require the extension of the center screw to provide for clearance of the gear doors.

Raising Aircraft

Apply jack pressure on each jack without lifting the aircraft, and check to see that the base of each jack is evenly seated. Correct base position of jack, as required, for firm base seating. For shipboard operations, all jacks must be tie-down before jacking aircraft with a minimum of three tie-down chains per jack. The jack must be tied down at the spring-loaded wheel caster mounts, thus allowing the jacks to make small movements with the aircraft jack points. Release the aircraft parking brake. Remove main landing gear chocks. Jack aircraft evenly and extend tie-down chains while jacking. Extension of tie-down chains must be coordinated in a way that preload on each tie-down chain is partially removed before jacking. Partial

preload is maintained with jacking of aircraft by rotation of the chain tensioning grip.

CAUTION

Use extreme care to raise wing jacks in coordinated, small, equal amounts. Preload on the tie-down chain is too high when tensioning grip cannot be rotated manually.

Screw the lock collar down as each jack is being extended. Jack the aircraft until its wheels clear the deck, and set the lock collar handtight. Set each tie-down chain to preload by manually rotating and tightening tensioning grip.

Leveling Aircraft

An aircraft leveling technique is shown in figure 1-32. Jack aircraft at wing and nose jack point as described earlier. Attach plumb bob and string to eye bolt at FS 259 (fuselage station). Position the plumb bob directly over the leveling plate on floor of aircraft. Level aircraft laterally (left to right) by adjusting wing jacks until plumb bob tip is directly above the center line in the leveling plate. Level the aircraft longitudinally (forward and aft) by adjusting the nose jack until plumb bob tip is directly above FS 259 line on

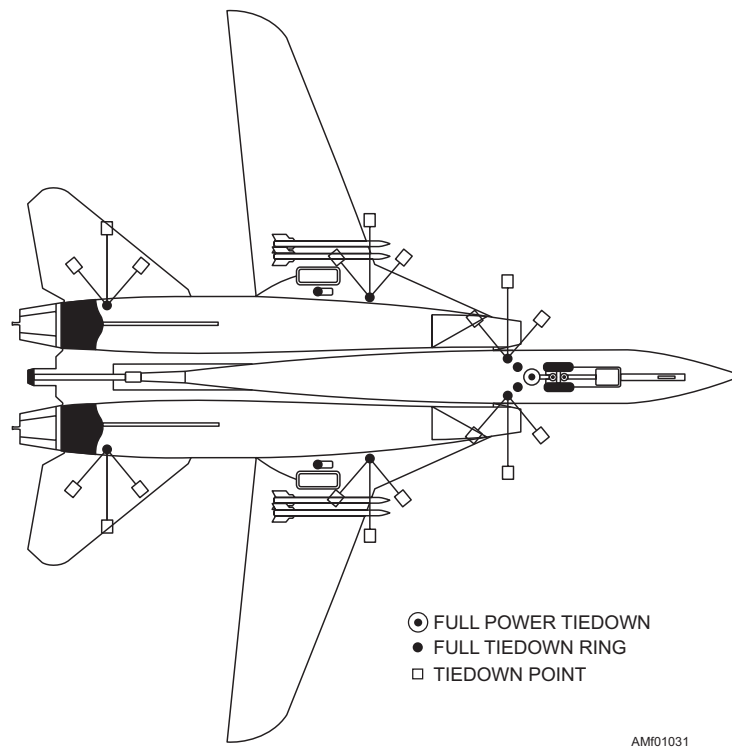

Figure 1-31.—Carrier tie-downs for aircraft jacking.

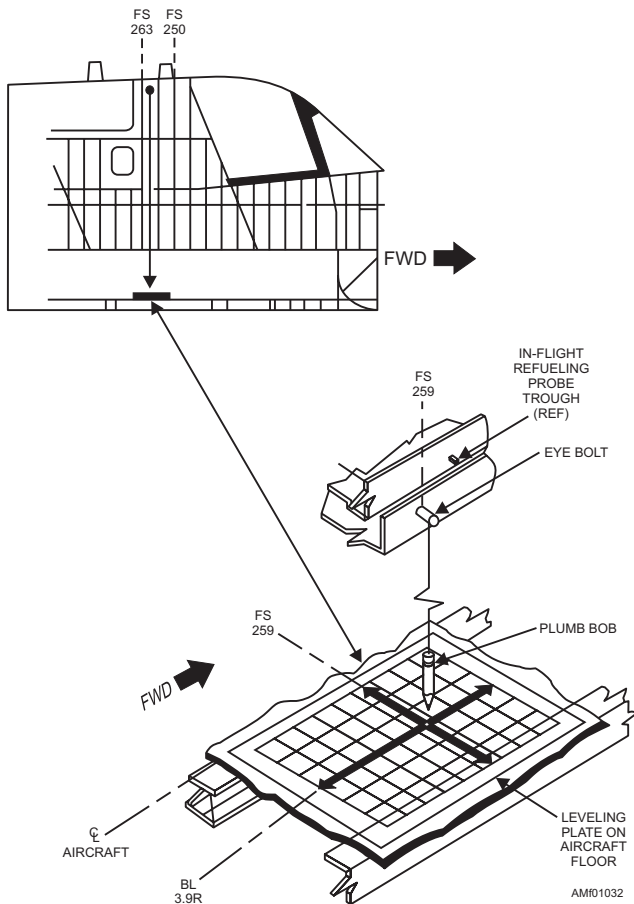

Figure 1-32.—Aircraft leveling.

the leveling plate. This procedure varies greatly with different types of aircraft. You must use the applicable MIM to perform a leveling procedure.

Lowering Aircraft

Make sure that landing gear safety pins are installed. Make sure that the arresting hook is retracted. Install arresting hook safety pin, or verify that it is installed. Verify that the landing gear handle in the flight station is in the DN (down) position. Lubricate exposed surfaces of the shock strut piston and nose oleo strut with clean hydraulic fluid.

NOTE: Wiping down oleo struts with hydraulic fluid helps to prevent them from sticking.

Apply jacking pressure and loosen the lock collar on wing jacks and nose jack. Lower all jacks evenly and

slowly, while maintaining preload on tie-down chains by manually rotating tensioning grips. Lower jacks until landing gear wheels are on deck and jacks are clear of jack pads by a safe margin.

CAUTION

Jacks should be promptly removed from the aircraft's underside to prevent structural damage to the aircraft in the event of settling.

WARNING

Make sure that the aircraft main and nose landing gear struts have settled to their normal position prior to entering main or nose landing gear wheel wells. Failure to allow landing gear to settle could result in personnel injury.

Install chocks and apply parking brakes. Remove jacks. Remove jack adapters and install/remove aircraft mooring adapters and tie-down chains as required by the MIM. Secure the aircraft, and ensure all protective covers and ground safety devices are installed. Clean up the area and stow all equipment.

- Q1-39. What are the two types of hydraulic aircraft jacks used by the Navy?
- Q1-40. Aircraft jacks are serviced with what type of fluid?
- Q1-41. What type of jack is used for changing aircraft tires?
- Q1-42. What division performs 13-week special inspections on axle jacks?
- Q1-43. What important safeguard prevents you from lowering a jack too fast?
- Q1-44. Details on jacking restrictions and procedures can be found in what publication?
- Q1-45. For shipboard operations, what is the minimum number of tie-down chains required for each jack?

CHAPTER 2

AIRCRAFT CONSTRUCTION AND MATERIALS

INTRODUCTION

The Aviation Structural Mechanic is required to be familiar with the various terms related to aircraft construction. Aircraft maintenance is the primary responsibility of the Aviation Structural Mechanic (AM) rating. Therefore, you should be familiar with the principal aircraft structural units and flight control systems of fixed and rotary-wing aircraft. The maintenance of the airframe is primarily the responsibility of the AM rating.

Each naval aircraft is built to meet certain specified requirements. These requirements must be selected in such a way that they can be built into one machine. It is not possible for one aircraft to have all characteristics. The type and class of an aircraft determine how strong it will be built. A Navy fighter, for example, must be fast, maneuverable, and equipped for both attack and defense. To meet these requirements, the aircraft is highly powered and has a very strong structure.

AIRCRAFT CONSTRUCTION

LEARNING OBJECTIVE: Identify the principal structural units of fixed-wing and rotary-wing aircraft.

The airframe of a fixed-wing aircraft consists of five principal units. These units include the fuselage, wings, stabilizers, flight control surfaces, and landing gear. A rotary-wing aircraft consists of the fuselage, landing gear, main rotor assembly, and tail rotor. The following text describes the purpose, location, and construction features of each unit.

FIXED-WING AIRCRAFT

There are nine principal structural units of a fixed-wing (conventional) aircraft: the fuselage, engine mount, nacelle, wings, stabilizers, flight control surfaces, landing gear, arresting gear, and catapult equipment.

Fuselage

The fuselage is the main structure or body of the aircraft to which all other units attach. It provides space for the crew, passengers, cargo, most of the accessories,

and other equipment. Fuselages of naval aircraft have much in common from the standpoint of construction and design. They vary mainly in size and arrangement of the different compartments. Designs vary with the manufacturers and the requirements for the types of service the aircraft must perform.

The fuselage of most naval aircraft are of all-metal construction assembled in a modification of the monocoque design. The monocoque design relies largely on the strength of the skin or shell (covering) to carry the various loads. This design may be divided into three classes: *monocoque*, *semimonocoque*, and *reinforced shell*, and different portions of the same fuselage may belong to any of these classes. The monocoque has its only reinforcement vertical rings, station webs, and bulkheads. In the semimonocoque design, in addition to these the skin is reinforced by longitudinal members, that is, stringers and longerons, but has no diagonal web members. The reinforced shell has the shell reinforced by a complete framework of structural members. The cross sectional shape is derived from bulkheads, station webs, and rings. The longitudinal contour is developed with longerons, formers, and stringers. The skin (covering), which is fastened to all these members, carries primarily the shear load and, together with the longitudinal members, the loads of tension and bending stresses. Station webs are built up assemblies located at intervals to carry concentrated loads and at points where fittings are used to attach external parts such as wings alighting gear, and engine mounts. Formers and stringers may be single pieces of built-up sections.

The semimonocoque fuselage is constructed primarily of aluminum alloy; however, on newer aircraft graphite epoxy composite material is often used. Steel and titanium are found in areas subject to high temperatures. Primary bending loads are absorbed by the “longerons,” which usually extend across several points of support. The longerons are supplemented by other longitudinal members, called “stringers.” Stringers are lighter in weight and are used more extensively than longerons. The vertical structural members are referred to as “bulkheads, frames, and formers.” These vertical members are grouped at intervals to carry concentrated loads and at points where fittings are used to attach other units, such as the

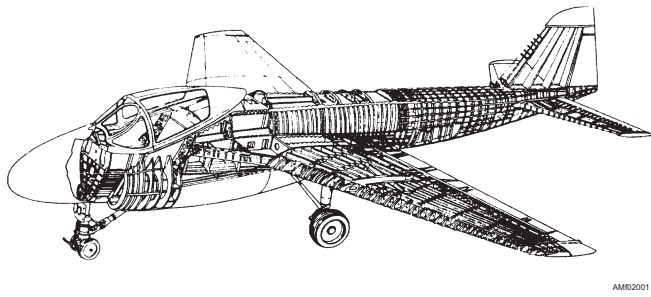

AM102001

Figure 2-1.—Semimonocoque fuselage construction.

wings, engines, and stabilizers. Figure 2-1 shows a modified form of the monocoque design used in combat aircraft. The skin is attached to the longerons, bulkheads, and other structural members and carries part of the load. Skin thickness varies with the loads carried and the stresses supported.

There are many advantages in the use of the semimonocoque fuselage. The bulkheads, frames, stringers, and longerons aid in the construction of a streamlined fuselage. They also add to the strength and rigidity of the structure. The main advantage of this design is that it does not depend only on a few members for strength and rigidity. All structural members aid in the strength of the fuselage. This means that a semimonocoque fuselage may withstand considerable damage and still remain strong enough to hold together.

On fighters and other small aircraft, fuselages are usually constructed in two or more sections. Larger aircraft may be constructed in as many as six sections. Various points on the fuselage are located by station number. A station on an aircraft may be described as a rib or frame number. Aircraft drawings use various systems of station markings. For example, the centerline of the aircraft on one drawing may be taken as the zero station. Objects to the right or left of center

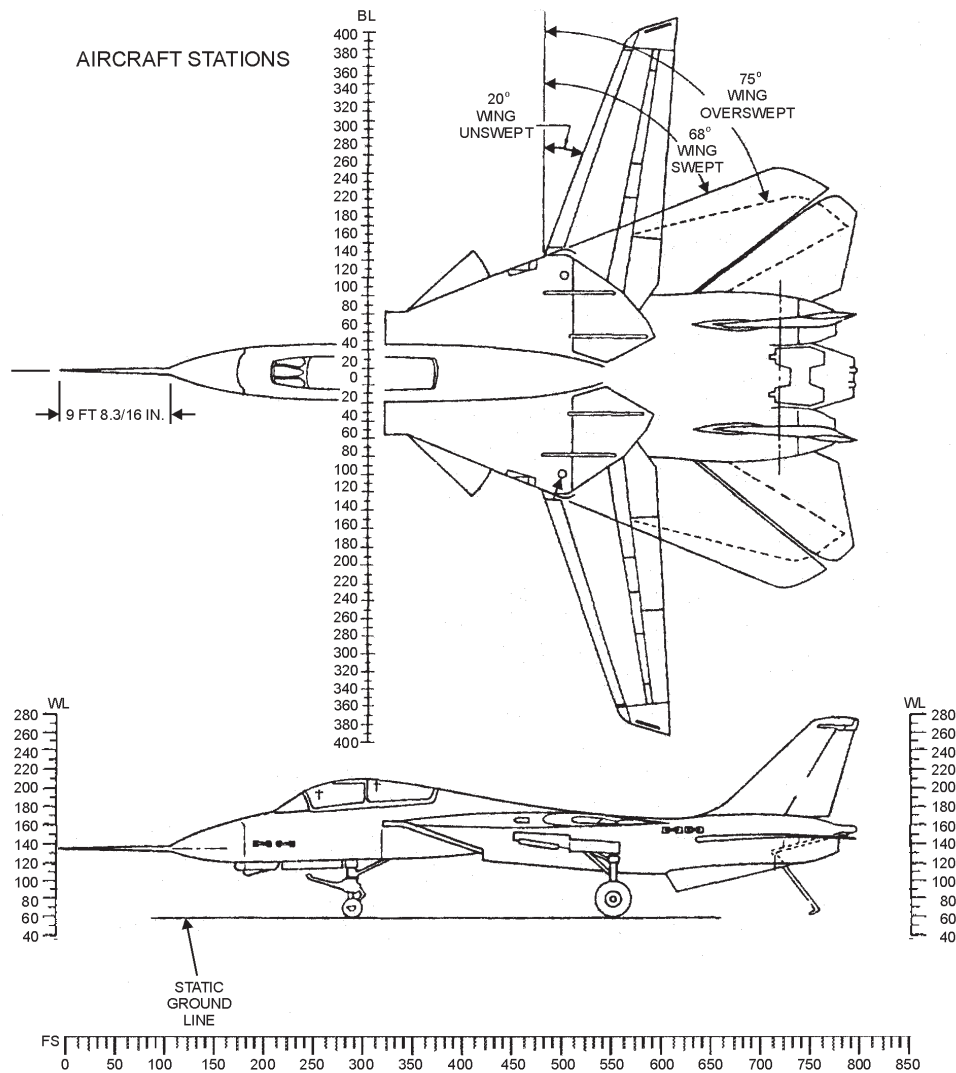

AM102002

Figure 2-2.—Typical fuselage station diagram.

along a wing or stabilizer are found by giving the number of inches between them and the centerline station zero. Figure 2-2 shows station numbers for a typical aircraft.

Station 0 (zero) is usually located at or near the nose of the aircraft. The other fuselage stations (FS) are located at distances measured in inches aft of station 0. On this particular aircraft, station 0 is located 93.0 inches forward of the nose. A typical nose station diagram is shown in figure 2-3.

Quick access to the accessories and other equipment carried in the fuselage is through numerous doors, inspection panels, wheel wells, and other openings. Servicing diagrams showing the arrangement of equipment and the location of access doors are supplied by the manufacturer in the maintenance instruction manuals and maintenance requirement cards for each model or type of aircraft.

Engine Mounts

Engine mounts are designed to meet particular conditions of installations, such as their location on the aircraft; methods of attachment; and size, type, and characteristics of the engine they are intended to support. Although engine mounts vary widely in their appearance and in the arrangement of their members, the basic features of their construction are similar. They are usually constructed as a single unit that may be detached quickly and easily from the remaining structure. In many cases, they are removed as a complete assembly or power plant with the engine and its accessories. Vibrations originating in the engine are transmitted to the aircraft structure through the engine mount.

Nacelles

In single-engine aircraft, the power plant is mounted in the center of the fuselage. On multiengine aircraft, nacelles are usually used to mount the power plants. The nacelle is primarily a unit that houses the engine. Nacelles are similar in shape and design for the same size aircraft. They vary with the size of the aircraft. Larger aircraft require less fairing, and therefore smaller nacelles. The structural design of a nacelle is similar to that of the fuselage. In certain cases the nacelle is designed to transmit engine loads and stresses to the wings through the engine mounts.

Wings

The wings of an aircraft are designed to develop lift when they are moved through the air. The particular wing design depends upon many factors; for example, size, weight, use of the aircraft, desired landing speed, and desired rate of climb. In some aircraft, the larger compartments of the wings are used as fuel tanks. The wings are designated as right and left, corresponding to the right- and left-hand sides of a pilot seated in the aircraft.

The wing structures of most naval aircraft are of an all-metal construction, usually of the cantilever design; that is, no external bracing is required. Usually wings are of the stress-skin type. This means that the skin is part of the basic wing structure and carries part of the loads and stresses. The internal structure is made of "spars and stringers" running spanwise, and "ribs and formers" running chordwise (leading edge to trailing edge). The spars are the main structural members of the wing, and are often referred to as "beams."

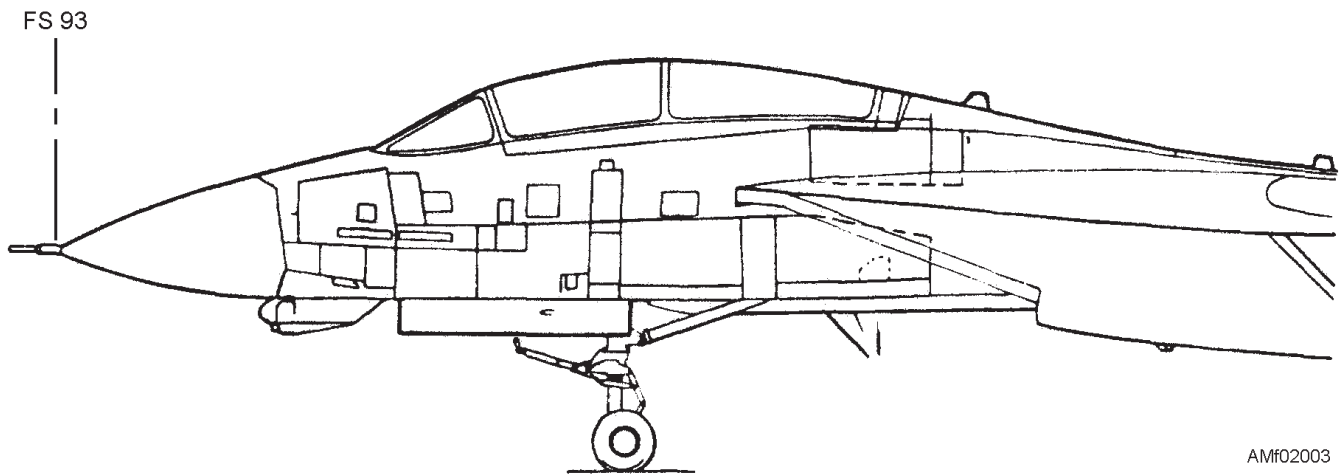

Figure 2-3.—Typical nose station diagram.

One method of wing construction is shown in figure 2-4. In this illustration, two main spars are used with ribs placed at frequent intervals between the spars to develop the wing contour. This is called “two-spar” construction. Other variations of wing construction include “monospar (open spar), multispar (three or more spars), and box beam.” In the box beam construction, the stringers and sparlike sections are joined together in a box-shaped beam. Then the remainder of the wing is constructed around the box.

The skin is attached to all the structural members and carries part of the wing loads and stresses. During flight, the loads imposed on the wing structure act primarily on the skin. From the skin, the loads are transmitted to the ribs and then to the spars. The spars support all distributed loads as well concentrated weights, such as a fuselage, landing gear, and nacelle. Corrugated sheet aluminum alloy is often used as a subcovering for wing structures. The Lockheed P-3 Orion wing is an example of this type of construction.

Inspection and access panels are usually provided on the lower surface of a wing. Drain holes are also placed in the lower surfaces. Walkways are provided on the areas of the wing where personnel should walk or step. The substructure is stiffened or reinforced in the vicinity of the walkways to take such loads. Walkways are usually covered with a nonskid surface. Some aircraft have no built-in walkways. In these cases removable mats or covers are used to protect the wing surface. On some aircraft, jacking points are provided on the underside of each wing. The jacking points may also be used as tiedown fittings for securing the aircraft.

Various points on the wing are located by station number. Wing station 0 (zero) is located at the centerline of the fuselage. All wing stations are

measured in inches outboard from that point, as shown in figure 2-2.

Stabilizers

The stabilizing surfaces of an aircraft consist of vertical and horizontal airfoils. These are known as the vertical stabilizer (or fin) and the horizontal stabilizer. These two airfoils, together with the rudder and elevators, form the tail section. For inspection and maintenance purposes, the entire tail section is considered a single unit of the airframe, and is referred to as the “empennage.”

The primary purpose of the stabilizers is to stabilize the aircraft in flight, that is, to keep the aircraft in straight and level flight. The vertical stabilizer maintains the stability of the aircraft about its vertical axis. This is known as “directional stability.” The vertical stabilizer usually serves as the base to which the rudder is attached. The horizontal stabilizer provides stability of the aircraft about the lateral axis. This is “longitudinal stability.” It usually serves as the base to which the elevators are attached.

At high speeds, forces acting upon the flight controls increase, and control of the aircraft becomes difficult. This problem can be solved through the use of power-operated or power-boostered flight control systems. These power systems make it possible for the pilot to apply more pressure to the control surface against the air loads. By changing the angle of attack of the stabilizer, the pilot maintains adequate longitudinal control by rotating the entire horizontal stabilizer surface.

Construction features of the stabilizers are in many respects identical to those of the wings. They are usually of an all-metal construction and of the

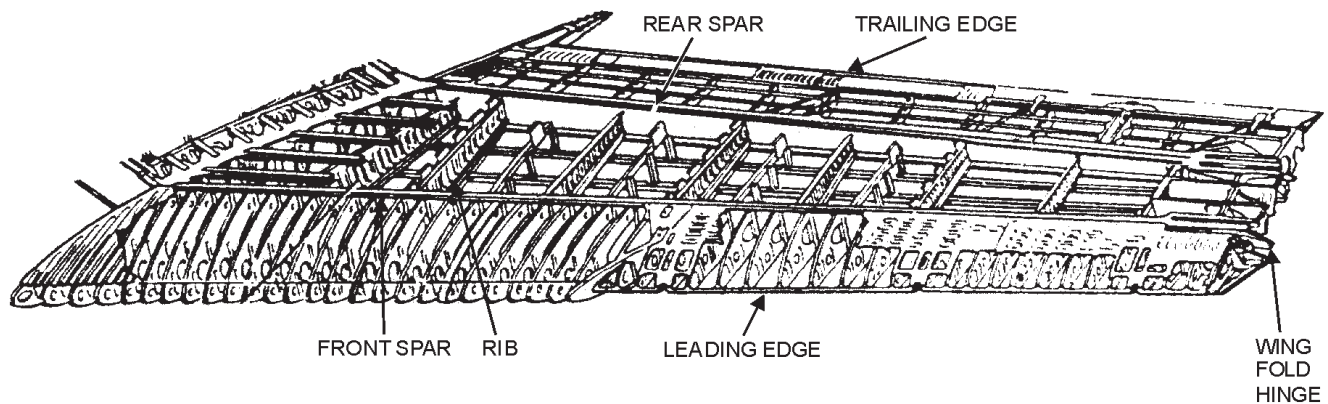

AMf02004

Figure 2-4.—Typical wing construction.

cantilever design. Monospar and two-spar construction are both commonly used. Ribs develop the cross-sectional shape. A “fairing” is used to round out the angles formed between these surfaces and the fuselage.

The construction of control surfaces is similar to that of the wing and stabilizers. They are usually built around a single spar or torque tube. Ribs are fitted to the spar near the leading edge. At the trailing edge, they are joined together with a suitable metal strip or extrusion. For greater strength, especially in thinner airfoil sections typical of trailing edges, a composite construction material is used.

On most modern day fighters like the F/A-18 there is also a stabilator incorporated as part of the flight controls. The stabilator is a control surface located on either side of the tail. In flight, the stabilator deflects symmetrically to produce pitch motion and asymmetrically to produce roll motion. The maximum surface deflection of each stabilator is 10.5 degrees trailing edge down to 24 degrees trailing edge up.

Flight Control Surfaces

The flight control surfaces are hinged or movable airfoils designed to change the attitude of the aircraft during flight. Flight control surfaces are grouped as systems and are classified as being either primary or secondary. Primary controls are those that provide control over the yaw, pitch, and roll of the aircraft. Secondary controls include the speed brake and flap systems. All systems consist of the control surfaces, cockpit controls, connecting linkage, and other necessary operating mechanisms.

The systems discussed in this chapter are representative of those with which you will be working. However, you should bear in mind that changes in these systems are sometimes necessitated as a result of later experience and data gathered from fleet use. Therefore, prior to performing the maintenance procedures discussed in this chapter, you should consult the current applicable technical publications for the latest information and procedures to be used.

Primary Flight Control Systems

The primary flight controls are the ailerons, elevators, and rudder. The ailerons and elevators are operated from the cockpit by a control stick on fighter aircraft. A wheel and yoke assembly is used on large aircraft such as transports and patrol planes. The rudder is operated by rudder pedals on all types of aircraft.

The ailerons are operated by a lateral (side-to-side) movement of the control stick or a turning motion of the wheel on the yoke. The ailerons are interconnected in the control system and work simultaneously, but in opposite directions to one another. As one aileron moves downward to increase lift on its side of the fuselage, the aileron on the opposite side of the fuselage moves upward to decrease lift. This opposing action allows more lift to be produced by the wing on one side of the fuselage than on the other side. This results in a controlled movement or roll because of unequal forces on the wings. The aileron system can be improved with the use of either powered controls or alternate control systems.

The elevators are operated by a fore-and-aft movement of the control stick or yoke. Raising the elevators causes the aircraft to climb. Lowering the elevators causes it to dive or descend. The pilot raises the elevators by pulling back on the stick or yoke and lowers them by pushing the stick or yoke forward.

The rudder is connected to the rudder pedals and is used to move the aircraft about the vertical axis. If the pilot moves the rudder to the right, the aircraft turns to the right; if the rudder is moved to the left, the aircraft turns to the left. The pilot moves the rudder to the right by pushing the right rudder pedal, and to the left by pushing the left rudder pedal.

Power control systems are used on high-speed jet aircraft. Aircraft traveling at or near supersonic speeds have such high air loads imposed upon the primary control surfaces that the pilot cannot control the aircraft without power-operated or power-boosted flight control systems. In the power-boost system, a hydraulically operated booster cylinder is incorporated within the control linkage to assist the pilot in moving the control surface. The power-boost cylinder is still used in the rudder control system of some high-performance aircraft; however, the other primary control surfaces use the full power-operated system. In the full power-operated system, all force necessary for operating the control surface is supplied by hydraulic pressure. Each movable surface is operated by a hydraulic actuator (or power control cylinder) incorporated into the control linkage.

In addition to the current Navy specification requiring two separate hydraulic systems for operating the primary flight control surfaces, specifications also call for an independent hydraulic power source for emergency operation of the primary flight control surfaces. Some manufacturers provide an emergency system powered by a motor-driven hydraulic pump;

others use a ram-air-driven turbine for operating the emergency system pump.

Lateral Control Systems

Lateral control systems control roll about the longitudinal axis of the aircraft. On many aircraft the aileron is the primary source of lateral control. On other aircraft flaperons and spoilers are used to control roll.

AILERONS.—Some aircraft are equipped with a power mechanism that provides hydraulic power to operate the ailerons. When the control stick is moved, the control cables move the power mechanism sector. Through linkage, the sector actuates the control valves, which, in turn, direct hydraulic fluid to the power cylinder. The cylinder-actuating shaft, which is connected to the power crank through a latch mechanism, operates the power crank. The crank moves the push-pull tubes, which actuate the ailerons.

In the event of complete hydraulic power failure, the pilot may pull a handle in the cockpit to disconnect the latch mechanisms from the cylinder and load-feel bungee. This places the aileron system in a manual mode of operation. In manual operation, the cable sector actuates the power crank.

This lateral control system incorporates a load-feel bungee, which serves a dual purpose. First, it provides an artificial feeling and centering device for the aileron system. Also, it is an interconnection between the aileron system and the aileron trim system. When the aileron trim actuator is energized, the bungee moves in a corresponding direction and actuates the power mechanism. The power mechanism repositions the aileron control system to a new neutral position.

FLAPERON.—As aircraft speeds increased, other lateral control systems came into use. Some aircraft use a flaperon system. The flaperon, shown in figure 2-5, is

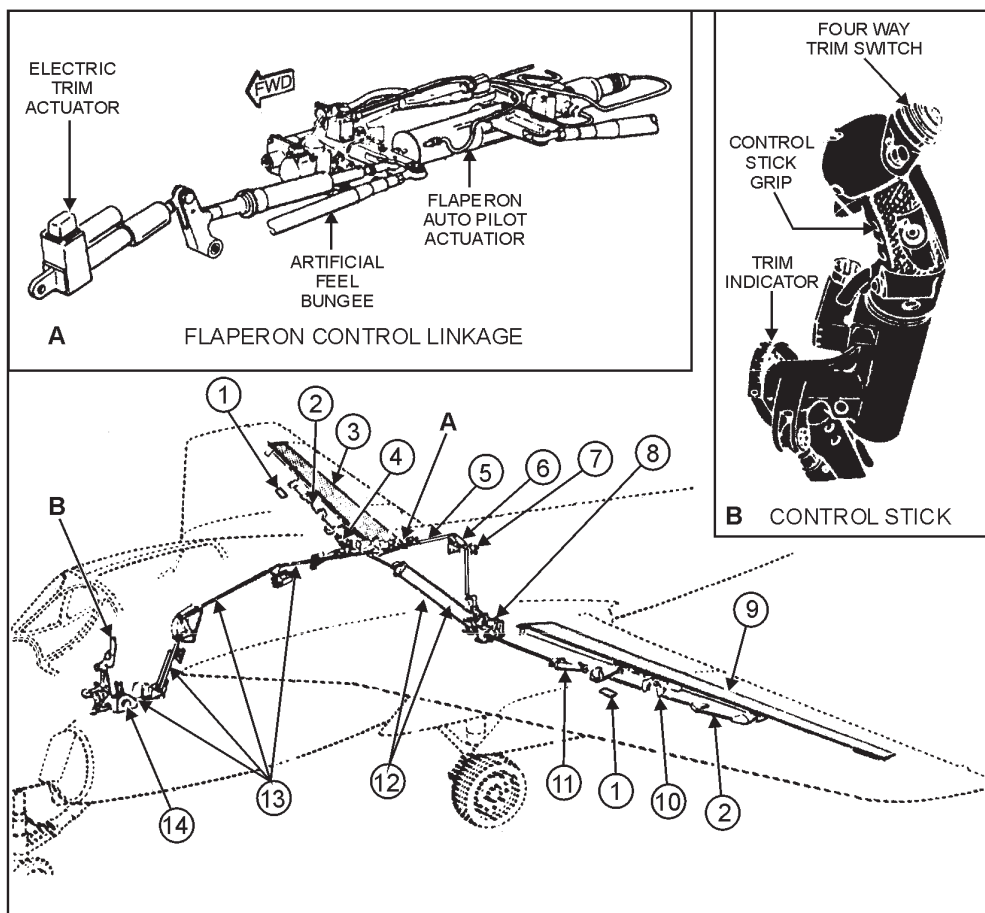

AMF02005

- | | | |
|--|---|-----------------------------------|
| 1. Wing-fold flaperon interlock switch | 6. Wing-fold interlock mechanism | 10. Flaperon control linkage |
| 2. Flaperon control linkage | 7. Filter | 11. Flaperon actuator (left wing) |
| 3. Right wing flaperons | 8. Flaperon pop-up mechanism and cylinder | 12. Crossover cables |
| 4. Flaperon actuator (right wing) | 9. Left wing flaperons | 13. Pushrods |
| 5. Flaperon pop-up valve | | 14. Throttle quadrant |

Figure 2-5.—Flaperon control system.

a device designed to reduce lift on the wing whenever it is extended into the airstream. With this system, control stick movement will cause the left or right flaperon to rise into the airstream and the opposite flaperon to remain flush with the wing surface. This causes a decrease of lift on the wing with the flaperon extended and results in a roll.

SPOILER/DEFLECTOR.—Many aircraft use a combination aileron and spoiler/deflector system for longitudinal control. The ailerons are located on the trailing edge of the outer wing panel and, unlike most aircraft, can be fully cycled with the wings folded. The spoiler/deflector on each wing operates in conjunction with the upward throw of the aileron on that wing. They are located in the left- and right-hand wing center sections, forward of the flaps. The spoiler extends upward into the airstream, disrupts the airflow, and causes decreased lift on that wing. The deflector extends down into the airstream and scoops airflow over the wing surface aft of the spoiler, thus preventing airflow separation in that area.

A stop bolt on the spoiler bell crank limits movement of the spoiler to 60 degrees deflection. The deflector is mechanically slaved to the spoiler, and can be deflected a maximum of 30 degrees when the spoiler is at 60 degrees. The spoilers open only with the upward movement of the ailerons.

Longitudinal Control Systems

Longitudinal control systems control pitch about the lateral axis of the aircraft. Many aircraft use a

conventional elevator system for this purpose. However, aircraft that operate in the higher speed ranges usually have a movable horizontal stabilizer. Both types of systems are discussed in the following text.

ELEVATOR CONTROL SYSTEM.—A typical conventional elevator control system is operated by the control stick in the cockpit, and is hydraulically powered by the elevator power mechanism. The operation of the elevator control system is initiated when the control stick is moved fore or aft. When the stick is moved, it actuates the control cables that move the elevator control bell crank. The bell crank transmits the movement to the power mechanism through the control linkage. In turn, the power mechanism actuates a push-pull tube, which deflects the elevators up or down. If the hydraulic system fails, the cylinder can be disconnected. In this condition the controls work manually through the linkage of the mechanism to actuate the elevators.

HORIZONTAL STABILIZER CONTROL SYSTEM.—Horizontal stabilizer control systems are given a variety of names by the various aircraft manufacturers. Some aircraft systems are defined as a unit horizontal tail (UHT) control systems, while others are labeled the stabilator control system. Regardless of the name, these systems function to control the aircraft pitch about its lateral axis.

The horizontal stabilizer control system of the aircraft shown in figure 2-6 is representative of the systems used in many aircraft. The slab-type stabilizer

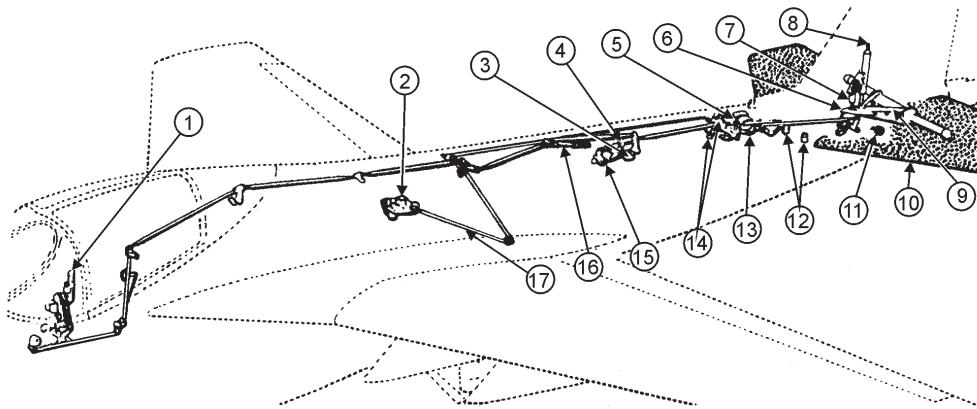

AMF02006

- | | | |
|-------------------------------|------------------------------------|---------------------------------------|
| 1. Control stick | 7. Load-relief bungee | 13. Negative bobweight |
| 2. Flap drive gearbox | 8. Stabilizer actuator | 14. Clean and dirty switches |
| 3. Trim transmitter | 9. Stabilizer support shaft | 15. Electrical trim actuator |
| 4. Artificial feel bungee | 10. Stabilizer | 16. Static spring |
| 5. Stabilizer shift mechanism | 11. Stabilizer position transducer | 17. Stabilizer shift mechanism cables |
| 6. Walking beam | 12. Filters | |

Figure 2-6.—Horizontal stabilizer system.

responds to fore-and-aft manual inputs at the control stick and to automatic flight control system inputs introduced at the stabilizer actuator. The actuator can operate in three modes: manual, series, or parallel.

Manual Mode.—In this mode, pilot input alone controls the power valve.

Series Mode.—In this mode, input signals from the automatic flight control system (AFCS) may be used independently or combined with manual inputs to control stabilizer movement.

Parallel Mode.—In this mode, input signals from the AFCS alone control stabilizer movement.

Directional Control Systems

Directional control systems provide a means of controlling and stabilizing the aircraft about its vertical axis. Most aircraft use conventional rudder control systems for this purpose. The rudder control system is operated by the rudder pedals in the cockpit, and is powered hydraulically through the power mechanism. In the event of hydraulic power failure, the hydraulic portion of the system is bypassed, and the system is powered mechanically through control cables and linkage. When the pilot depresses the rudder pedals, the control cables move a cable sector assembly. The cable sector, through a push-pull tube and linkage, actuates the power mechanism and causes deflection of the rudder to the left or right.

F-14 Flight Control Systems

The F-14 flight control systems include the rudder, the stabilizer, and the spoiler control systems; the wing

surfaces control system; the angle-of-attack system; and the speed brake control system. Because of the complexity of the F-14 flight control systems, only a brief description is presented.

RUDDER CONTROL (YAW AXIS).—Rudder control, which affects the yaw axis, is provided by way of the rudder pedals. Rudder pedal movement is mechanically transferred to the left and right rudder servo cylinders by the rudder feel assembly, the yaw summing network, and a reversing network.

SPOILER CONTROL (LATERAL AXIS).—Spoiler control is provided through the control stick grip, roll command transducer, roll computer, pitch computer, and eight spoiler actuators (one per spoiler). The spoilers, when used to increase the effect of roll-axis control can only be controlled when the wings are swept forward of 57 degrees. Right or left movement of the control stick grip is mechanically transferred to the roll command transducer, which converts the movement to inboard and outboard spoiler roll commands.

DIRECT LIFT CONTROL (DLC).—DLC moves the spoilers and horizontal stabilizers to increase aircraft vertical descent rate during landings without changing engine power.

WING SURFACE CONTROL SYSTEM.—The wing surface control system controls the variable-geometry wings to maximize aircraft performance at all speeds and altitudes. The system also provides high lift and drag forces for takeoff and landing, and increased lift for slow speeds. At supersonic speeds, the system produces aerodynamic lift to reduce trim drag.

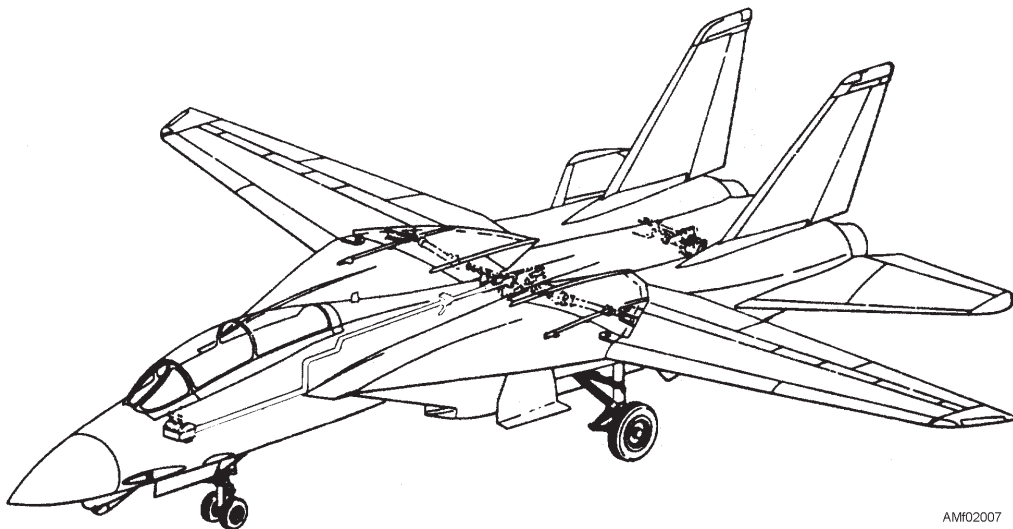

AM02007

Figure 2-7.—Wing sweep control system (F-14).

The wing sweep control, initiated at the throttle quadrant, provides electronic or mechanical control of a hydromechanical system that sweeps the wings. See figure 2-7. The wings can be swept from 20 degrees through 68 degrees in flight. On the ground, mechanical control allows a wing sweep position of 75 degrees. See figure 2-8. This position is used when flight deck personnel spot the aircraft or when maintenance personnel need to enable the wing sweep control self-test.

Electronic Control.—Wing sweep using electronic control is initiated at the throttle quadrant. Four modes are available: automatic, aft manual, forward manual, or bomb manual. Selection of these modes causes the air data computer to generate wing sweep commands consistent with the aircraft's speed, altitude, and configuration of the flaps and slats. If the automatic mode is used to apply the commands, the wings are positioned at a rate of 7.5 degrees per second.

Mechanical Control.—When wing sweep is in the mechanical control mode, the wing sweep handle uses the wing sweep/flap and slat control box to position the

wings. Because minimum wing sweep limiting is not available in the mechanical control mode, the wings can be swept to an adverse position that could cause damage to the wings. Mechanical control is used for emergency wing sweep and wing oversweep.

Secondary Flight Controls

Secondary flight controls include those controls not designated as primary controls. The secondary controls supplement the primary controls by aiding the pilot in controlling the aircraft. Various types are used on naval aircraft, but only the most common are discussed here.

TRIM TABS.—Trim tabs are small airfoils recessed in the trailing edge of a primary control surface. Their purpose is to enable the pilot to neutralize any unbalanced condition that might exist during flight, without exerting any pressure on the control stick or rudder pedals. Each trim tab is hinged to its parent control surface, but is operated independently by a separate control.

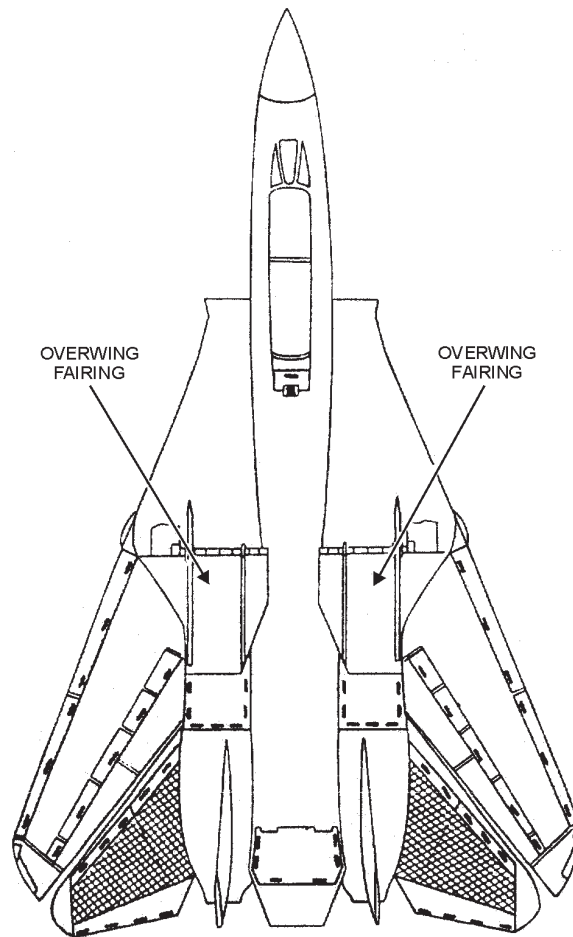

AMf02008

Figure 2-8.—Wing oversweep position—manual control (F-14).

The pilot moves the trim tab by using cockpit controls. The tab on the control surface moves in a direction opposite that of the desired control surface movement. The airflow striking the trim tab causes the larger surface to move to a position that will correct the unbalanced condition of the aircraft. For example, to trim a nose-heavy condition, the pilot sets the elevator trim tab in the “down” position. This causes the elevator to be moved and held in the “up” position, which, in turn, causes the tail of the aircraft to be lowered. Without the use of the trim tab, the pilot would have to hold the elevator in the up position by exerting constant pressure on the control stick or wheel.

Construction of trim tabs is similar to that of the other control surfaces, although greater use is being made of plastic materials to fill the tab completely. Filling the tab improves stiffness. Tabs may also be honeycomb filled. Tabs are covered with either metal or reinforced plastic. Trim tabs are actuated either electrically or manually.

WING FLAPS.—Wing flaps are used to give the aircraft extra lift. Their purpose is to reduce the landing speed, thereby shortening the length of the landing rollout. They are also used to assist in landing in small or obstructed areas by permitting the gliding angle to be increased without greatly increasing the approach speed. In addition, the use of flaps during takeoff serves to reduce the length of the takeoff run.

Most flaps are hinged to the lower trailing edges of the wings inboard of the ailerons, however, leading edge flaps are in use on some Navy aircraft. Four types of flaps are shown in figure 2-9. The **PLAIN** flap forms the trailing edge of the airfoil when the flap is in the up position. In the **SPLIT** flap, the trailing edge of the airfoil is split, and the bottom half is so hinged that it can be lowered to form the flap. The **FOWLER** flap operates on rollers and tracks. This causes the lower surface of the wing to roll out and then extend downward. The **LEADING EDGE** flap operates similarly to the plain flap. It is hinged on the bottom side and, when actuated, the leading edge of the wing actually extends in a downward direction to increase the camber of the wing. Leading edge flaps are used in conjunction with other types of flaps.

SPOILERS.—Spoilers are used for decreasing wing lift; however, their specific design, function, and use vary with different aircraft.

The spoilers on some aircraft are long, narrow surfaces hinged at their leading edge to the upper wing skin. In the retracted position, the spoiler is flush with

the wing skin. In the extended position, the spoiler is pivoted up and forward approximately 60 degrees above the hinge point. The spoilers disturb the smooth flow of air over the wing so that burbling takes place. The lift is consequently reduced, and considerable drag is added to the wing.

Another type of spoiler in common use is a long, slender, curved and perforated baffle that is raised edgewise through the upper surface of the wing forward of the aileron. It also disrupts the flow of air over the airfoil and destroys lift. These spoilers are actuated through the same linkage that actuates the ailerons. This arrangement makes movement of the spoiler dependent upon movement of the aileron. The linkage to the aileron is devised so that the spoiler is extended only when the aileron is raised. In other words, when the aileron moves downward, no deflection of the spoiler takes place.

SPEED BRAKES.—Speed brakes are hinged, movable control surfaces used for reducing the speed of aircraft. Some manufacturers refer to them as **dive brakes** or **dive flaps**. They are hinged to the sides or bottom of the fuselage or to the wings. Regardless of their location, speed brakes serve the same purpose on all aircraft. Their primary purpose is to keep aircraft from building up excessive speed during dives. They are also used in slowing down the speed of the aircraft prior to landing. Speed brakes are operated hydraulically or electrically.

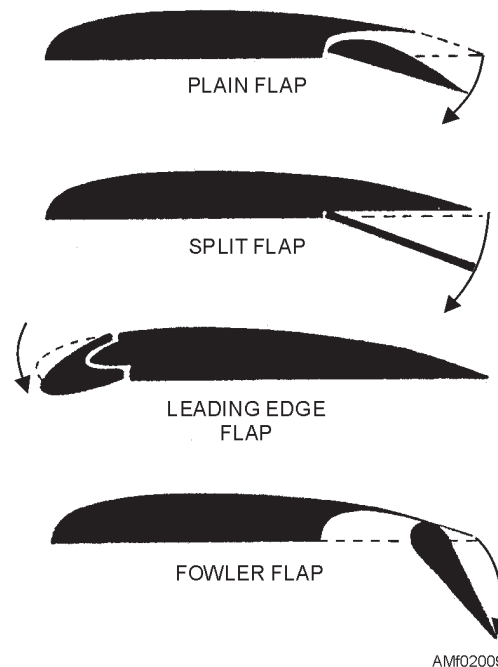

Figure 2-9.—Types of flaps.

SLATS.—Slats are movable control surfaces attached to the leading edge of the wing. When the slat is retracted, it forms the leading edge of the wing. At low airspeed, the slat improves the lateral control-handling characteristics and allows the aircraft to be controlled at airspeeds below the normal landing speed. When the slat is opened (extended forward), a slot is created between the slat and the leading edge of the wing. The slot allows high-energy air to be introduced into the air layer moving over the top of the wing. This is known as **boundary layer control**. Boundary layer control is primarily used during operations from carriers; that is, for catapult takeoffs and arrested landings. Boundary layer control can also be accomplished by a method of directing high-pressure engine bleed air through a series of narrow orifices located just forward of the wing flap leading edge.

AILERON DROOP.—The ailerons are also sometimes used to supplement the flaps. This is called an aileron droop feature. When the flaps are lowered, both ailerons can be partially deflected downward into the airstream. The partial deflection allows them to act as flaps as well as to serve the function of ailerons.

Landing Gear

The landing gear of the earliest aircraft consisted merely of protective skids attached to the lower surfaces of the wings and fuselage. As aircraft developed, skids became impractical and were replaced by a pair of wheels placed side by side ahead of the center of gravity with a tail skid supporting the aft section of the aircraft. The tail skid was later replaced by a swiveling tail wheel. This arrangement was standard on all land-based aircraft for so many years that it became known as the conventional landing gear. As the speed of aircraft increased, the elimination of drag became increasingly important. This led to the development of retractable landing gear.

Just before World War II, aircraft were designed with the main landing gear located behind the center of gravity and an auxiliary gear under the nose of the fuselage. This became known as the tricycle landing gear. It was a big improvement over the conventional type. The tricycle gear is more stable during ground operations and makes landing easier, especially in crosswinds. It also maintains the fuselage in a level position that increases the pilot's visibility. Nearly all Navy aircraft are equipped with tricycle landing gear. See figure 2-10 for a typical landing gear system.

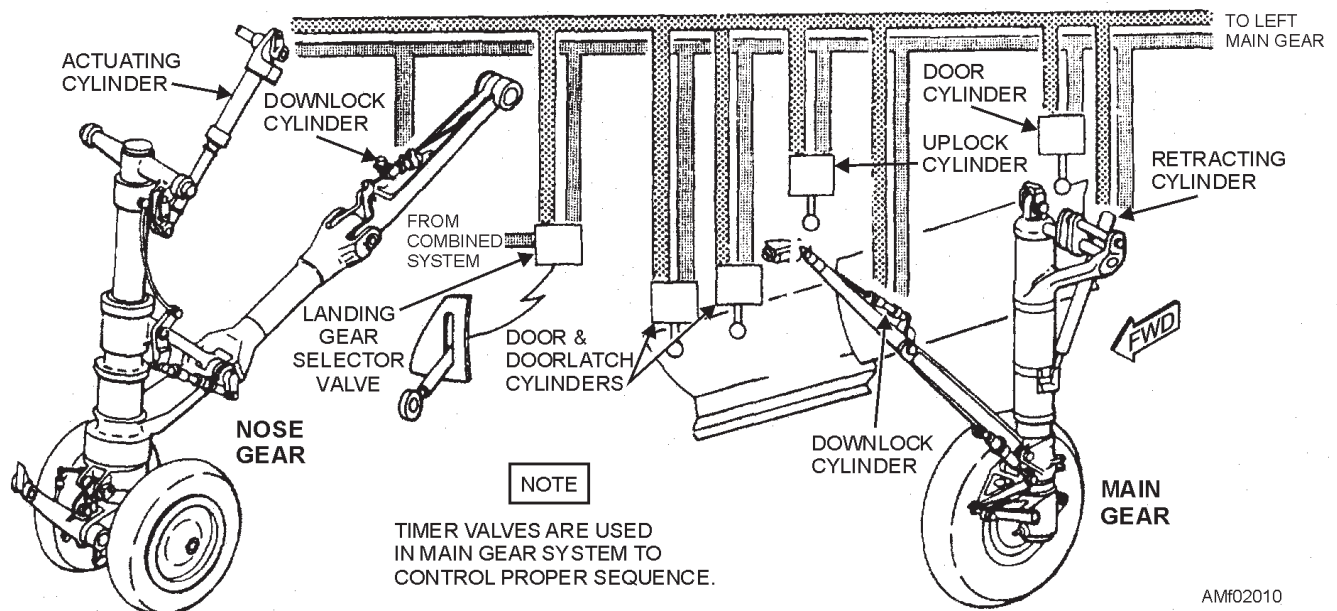

Figure 2-10.—Typical landing gear system.

Main Landing Gear

A main landing gear assembly is shown in figure 2-11. The major components of the assembly are the shock strut, tire, tube, wheel, brake assembly, retracting and extending mechanism, side brace, downlock actuator, and drag braces. Tires, tubes, and wheels are discussed in another chapter of this nonresident training course.

The shock strut absorbs the shock that otherwise would be sustained by the airframe structure during takeoff, taxiing, and landing. The air-oil shock strut is used on all Navy aircraft. This type of strut is composed essentially of two telescoping cylinders filled with hydraulic fluid and compressed air or nitrogen. Figure 2-12 shows the internal construction of a shock strut.

The telescoping cylinders, known as cylinder and piston, form an upper and lower chamber for the movement of the fluid. The lower chamber (piston) is always filled with fluid, while the upper chamber (cylinder) contains the compressed air or nitrogen. An orifice is placed between the two chambers through

which the fluid passes into the upper chamber during compression and returns during extension of the strut. The size of the orifice is controlled by the up-and-down movement of the tapered metering pin.

Whenever a load is placed on the strut because of the landing or taxiing of the aircraft, compression of the two strut halves starts. The piston (to which wheel and axle are attached) forces fluid through the orifice into the cylinder and compresses the air or nitrogen above it. When the strut has made a stroke to absorb the energy of the impact, the air or nitrogen at the top expands and forces the fluid back into the lower chamber. The slow metering of the fluid acts as a **snubber** to prevent rebounds. Instructions for the servicing of shock struts with hydraulic fluid and compressed air or nitrogen are contained on an instruction plate attached to the strut, as well as in the maintenance instruction manual (MIM) for the type of aircraft involved. The shock absorbing qualities of a shock strut depends on the proper servicing of the shock strut with compressed or nitrogen and the proper amount of fluid.

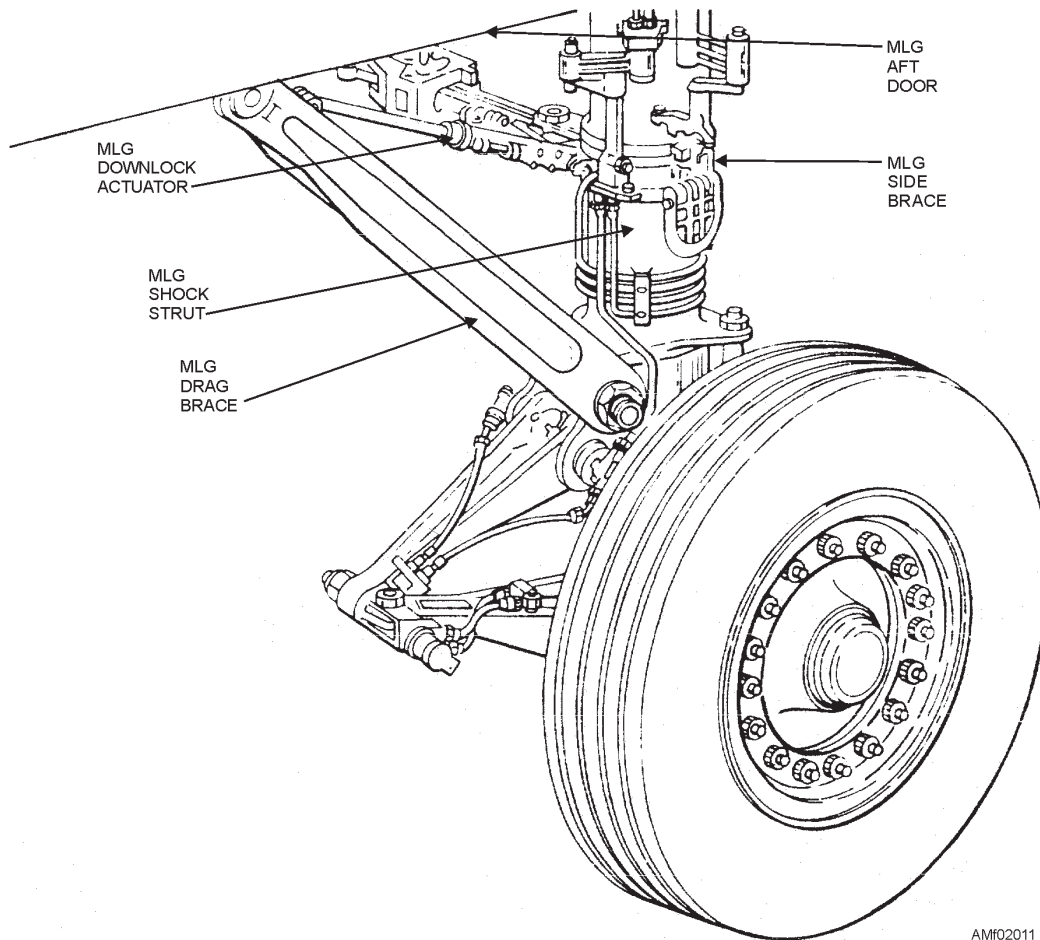
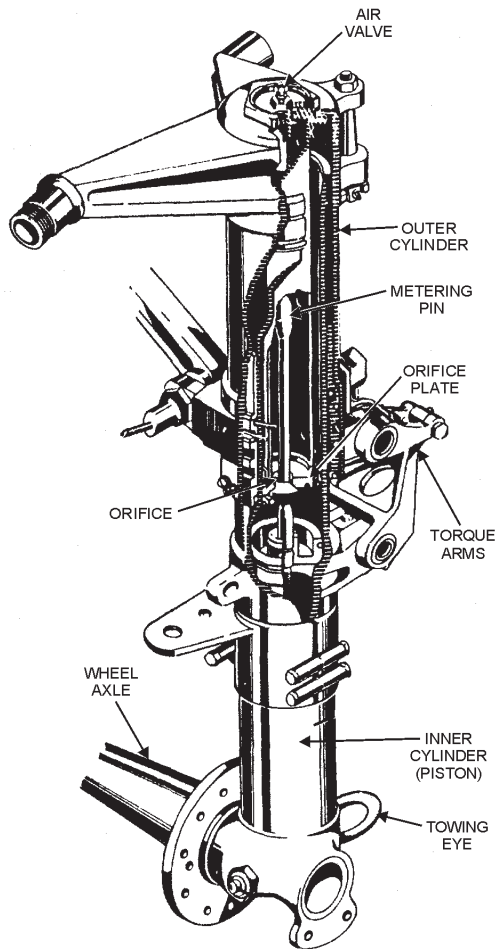

Figure 2-11.—Main landing gear.



AM02012

Figure 2-12.—Shock strut showing internal construction.

RETRACTING MECHANISMS.—Some aircraft have electrically actuated landing gear, but most are hydraulically actuated. Figure 2-11 shows a retracting mechanism that is hydraulically actuated. The landing gear control handle in the cockpit allows the landing gear to be retracted or extended by directing hydraulic fluid under pressure to the actuating cylinder. The locks hold the gear in the desired position, and the safety switch prevents accidental retracting of the gear when the aircraft is resting on its wheels.

A position indicator on the instrument panel indicates the position of the landing gear to the pilot. The position indicator is operated by the position-indicating switches mounted on the UP and DOWN locks of each landing gear.

EMERGENCY EXTENSION.—Methods of extending the landing gear in the event of normal system failure vary with different models of aircraft. Most aircraft use an emergency hydraulic system. Some aircraft use pneumatic (compressed air or

nitrogen), mechanical, or gravity systems, or a combination of these systems.

Nose Gear

A typical nose gear assembly is shown in figure 2-13. Major components of the assembly include a shock strut, drag struts, a retracting mechanism, wheels, and a shimmy damper.

The nose gear shock strut, drag struts, and retracting mechanism are similar to those described for the main landing gear. The shimmy damper is a self-contained hydraulic unit that resists sudden twisting loads applied to the nosewheel during ground operation, but permits slow turning of the wheel. The primary purpose of the shimmy damper is to prevent the nosewheel from shimmying (extremely fast left-right oscillations) during takeoff and landing. This is accomplished by the metering of hydraulic fluid through a small orifice between two cylinders or chambers.

Most aircraft are equipped with steerable nosewheels and do not require a separate self-contained shimmy damper. In such cases, the steering mechanism is hydraulically controlled and incorporates two spring-loaded hydraulic steering cylinders that, in addition to serving as a steering mechanism, automatically subdue shimmy and center the nosewheel.

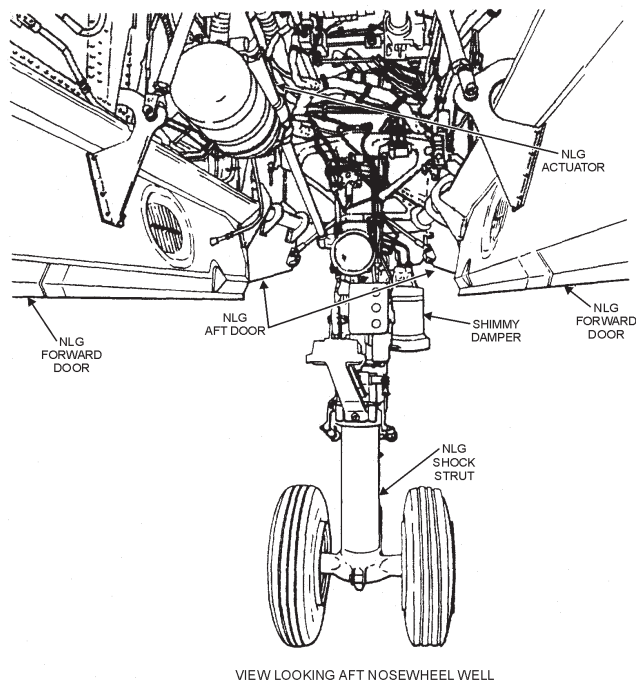

VIEW LOOKING AFT NOSEWHEEL WELL

AM02013

Figure 2-13.—Nose gear assembly.

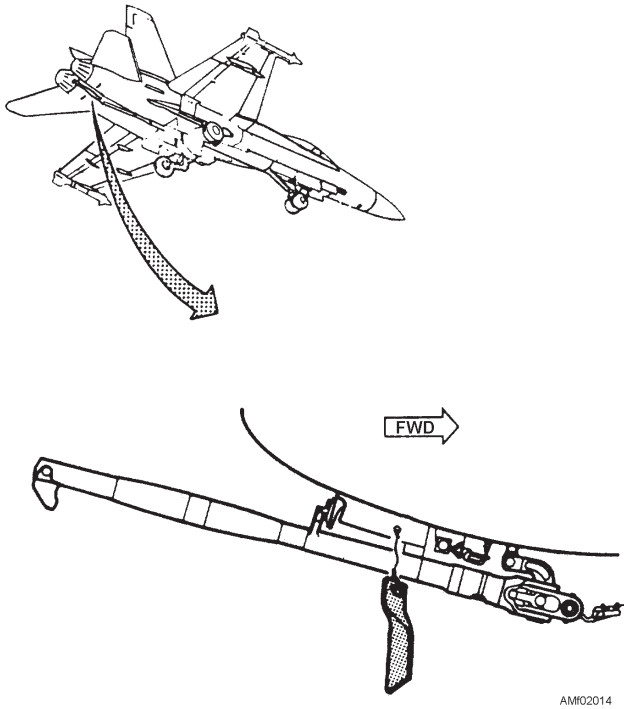

Figure 2-14.—Arresting gear installation.

Arresting Gear

A carrier aircraft is equipped with an arresting hook for stopping the aircraft when it lands on the carrier. See

figure 2-14. The arresting gear is composed of an extendible hook and the mechanical, hydraulic, and pneumatic equipment necessary for hook operation. The arresting hook on most aircraft is mechanically released, pneumatically lowered, and hydraulically raised.

The hook is hinged from the structure under the rear of the aircraft. A snubber, which meters hydraulic fluid and works in conjunction with nitrogen pressure, is used to hold the hook down to prevent it from bouncing when it strikes the carrier deck.

Catapult Equipment

Carrier aircraft are equipped with facilities for catapulting the aircraft off the aircraft carrier. This equipment consists of nose-toe launch equipment. The older aircraft have hooks that are designed to accommodate the cable bridle, which is used to hook the aircraft to the ship's catapult. The holdback assembly allows the aircraft to be secured to the carrier deck for full-power turnup of the engine prior to takeoff. The holdback tension bar separates when the catapult is fired and allows the aircraft to be launched with the engine at full power.

For nose gear equipment, a track is attached to the deck to guide the nosewheel into position. See figure 2-15. The track also has provisions for attaching the

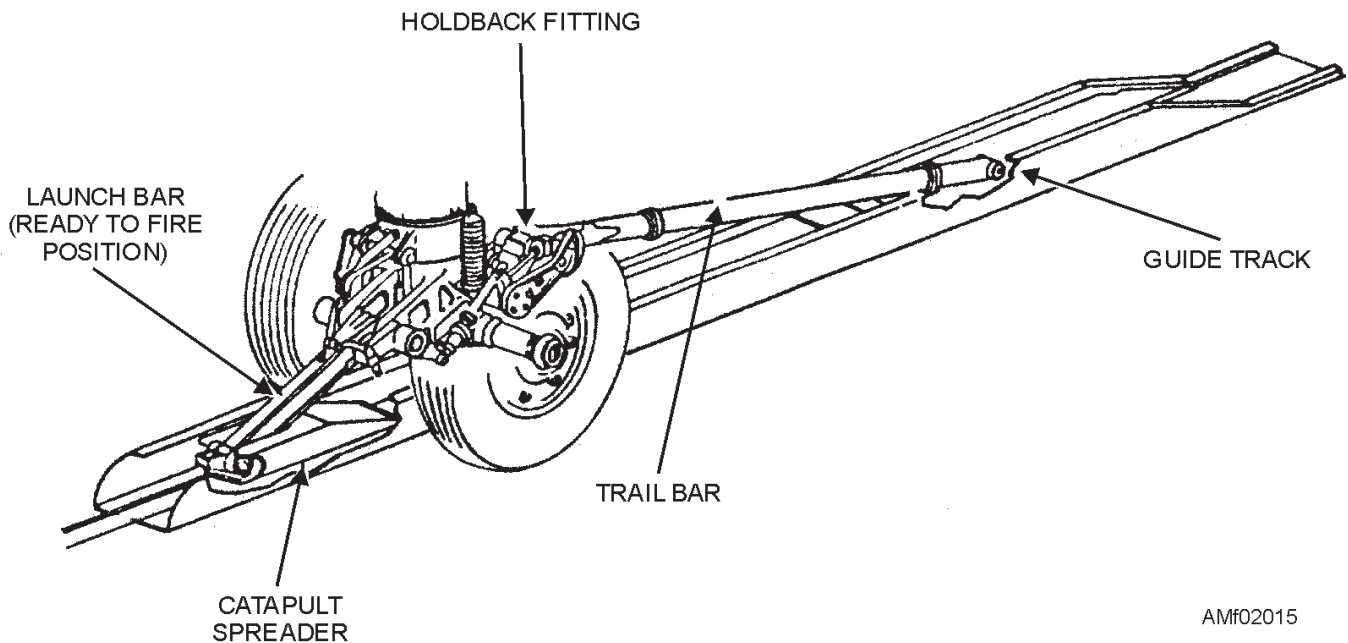

Figure 2-15.—Nose gear launch equipment.

nose gear to the catapult shuttle and for holdback. In comparison with the bridle and holdback pendant method of catapult hookup for launching, the nose gear launch equipment requires fewer personnel, the hookup is accomplished more safely, and time is saved in positioning an aircraft for launch.

ROTARY-WING AIRCRAFT

The history of rotary-wing development embraces 500-year-old efforts to produce a workable direct-lift-type flying machine. Aircraft designers' early experiments in the helicopter field were fruitless. It is only within the last 30 years that encouraging progress has been made. It is within the past 20 years that production line helicopters have become a reality. Today, helicopters are found throughout the world. They perform countless tasks especially suited to their unique capabilities. Helicopters are the modern-day version of the dream envisioned centuries ago by Leonardo da Vinci.

Early in the development of rotary-wing aircraft, a need arose for a new word to designate this direct-lift flying device. A resourceful Frenchman chose the two words—heliko, which means screw or spiral, and pteron, which means wing. The word helicopter is the combination of these two words.

A helicopter employs one or more power-driven horizontal airscrews, or rotors, from which it derives lift and propulsion. If a single rotor is used, it is necessary to employ a means to counteract torque. If more than one rotor is used, torque is eliminated by turning the rotors in opposite directions.

The fundamental advantage the helicopter has over conventional aircraft is that lift and control are independent of forward speed. A helicopter can fly forward, backward, or sideways, or it can remain in stationary flight (hover) above the ground. No runway is required for a helicopter to take off or land. The roof of an office building is an adequate landing area. The helicopter is considered a safe aircraft because the takeoff and landing speed is zero.

The construction of helicopters is similar to the construction of fixed-wing aircraft.

Fuselage

Like the fuselage in fixed-wing aircraft, helicopter fuselages may be welded truss or some form of monocoque construction. Many Navy helicopters are of the monocoque design. A typical Navy helicopter, the

H-60, is shown in figure 2-16. The fuselage consists of the entire airframe, sometimes known as the body group. The body group is of all-metal semimonocoque construction, consisting of an aluminum and titanium skin over a reinforced aluminum frame.

Landing Gear Group

The landing gear group includes all the equipment necessary to support the helicopter when it is not in flight. Conventional landing gear consists of a main landing gear and a nonretractable tail landing gear. See figure 2-16.

Main Landing Gear

The main landing gear system consists of nonretractable left and right single-wheel landing gear assemblies and the weight-on-wheels system. Each main landing gear assembly is composed of a shock strut, drag beam, axle, wheel, tire, and wheel brake. The left main landing gear assembly also includes a weight-on-wheels sensing switch.

The main landing gear supports the helicopter when on the ground, and cushions the helicopter from shock while landing. The weight-on-wheels switch provides helicopter ground/flight status indications for various helicopter systems.

Tail Landing Gear

The tail landing gear system consists of a dual-wheel landing gear, tail wheel lock system, and tail bumper. The tail landing gear is a cantilever type with an integral shock strut. The gear is capable of swiveling 360°. It can be locked in trail position by the tail wheel locking system. A tail recovery assist, secure, and traverse (RAST) probe is mounted on the tail gear.

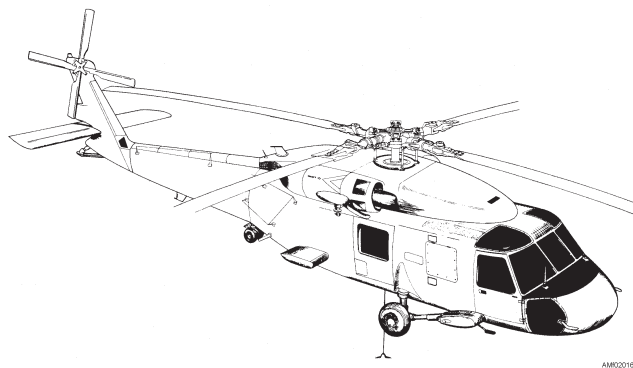

Figure 2-16.—H-60 helicopter.

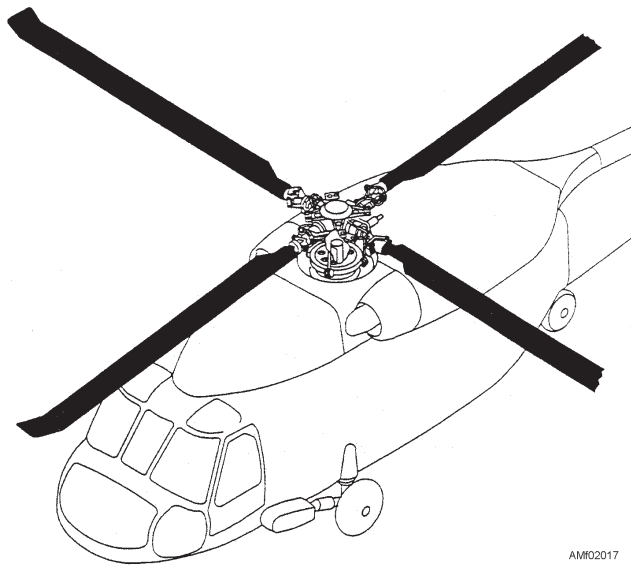

Figure 2-17.—H-60 main rotor blades.

Main Rotor Assembly

The main rotor (rotary wing) and the rotor head are discussed in the following section. Their functions are closely related and neither has a function without the other.

Rotor Wing

The H-60 has four main rotor blades that provide lift for the helicopter. See figure 2-17. They receive power from the main rotor head to which they are attached. The root (inboard end of the main rotor blade) allows bolting the main rotor blade to the main rotor head. A heater mat in the main rotor blade leading edge provides blade deicing, and it is connected to the blade deicing system.

Each main rotor blade has a pressurized titanium spar that is pressurized with nitrogen to detect cracks, honeycomb core, fiberglass skin, and nickel and titanium abrasion strips. A removable sweptback tip cap is attached by screws onto the end of each main rotor blade. Pressure loss in the spar is indicated through the use of a blade inspection method (BIM[®]) indicator. This indicator is located at each main rotor blade root, and continuously monitors spar pressure. See figure 2-18.

Rotor Head

The H-60 main rotor head transmits the movement of the flight controls to the four main rotor blades. The

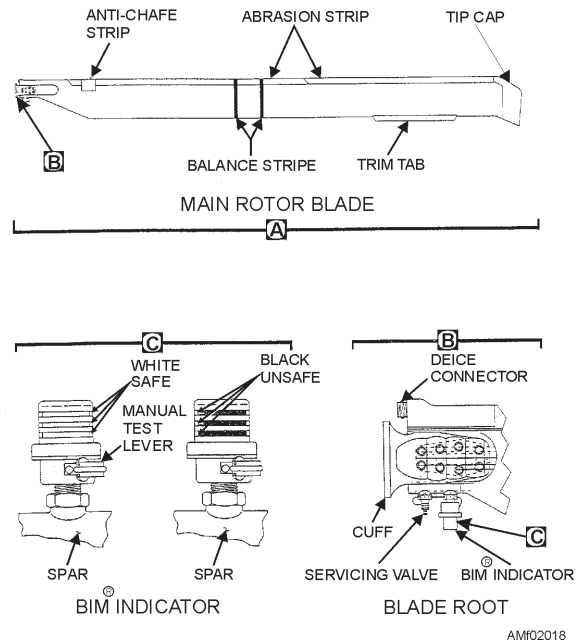

Figure 2-18.—H-60 main rotor blade pressurization system.

components of the main rotor head are as follows: hub, droops stops, bifilar absorber, pitch control rods, dampers, damper accumulator, anti-flap assemblies, swashplate, swashplate guide shaft extension, pressure plates, and rotor blade fold system. See figure 2-19.

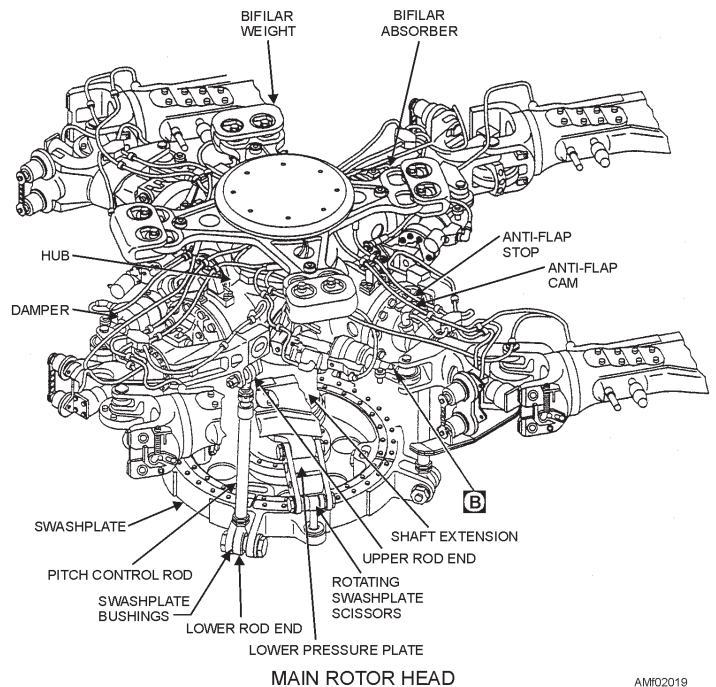

Figure 2-19.—H-60 main rotor head.

Main Rotor Pylon

The main rotor pylon is attached to the upper cabin and transition section. The forward section is made up of a sliding control/accessories fairing, removable platform, air inlet fairings, and engine air inlets. The mid-section includes the No. 1 and No. 2 work platform/engine access, left and right oil cooler access, environmental control system (ECS) access, APU inlet, APU access, and exhaust module. The aft section contains the fire bottle access and aft fairing.

Tail Rotor Assembly

The H-60 tail rotor is a bearingless, controllable pitch, cross-beam type system. The tail rotor blades are built around two interchangeable graphite composite spars that cross each other in the center. The two tail rotor blades are retained on the tail rotor hub by a set of retention plates. These plates bolt the tail rotor blades together to form four blades 90° apart. Counterweights are bolted to each tail rotor blade for balancing. See figure 2-20.

Tail Rudder Blades

The tail rotor blades are built around two graphite composite spars. The spar is the main structural

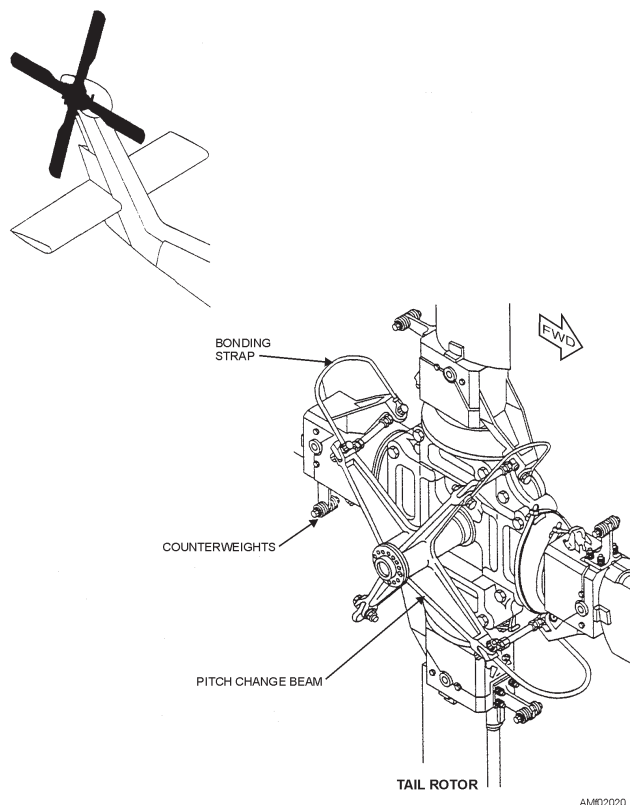

Figure 2-20.—H-60 tail rotor.

member of the tail rotor blade and is continuous from tip cap to tip cap. Two paddle assemblies, made up of honeycomb, are bonded to the spar. Several layers of fiberglass are bonded over the honeycomb and spar. These form the tail rotor blade skin and aerodynamic shape of the tail rotor blade. A deice heater mat is bonded into the tail rotor blade leading edge. The heater mat connects to an electrical connector mounted close to each counterweight. Power to heat the tail rotor blades is supplied through a slipring on the tail gearbox from the deice system.

Tail Pylon

The tail rotor pylon is a foldable section at the aft end of the helicopter. The pylon is supported by and hinged to the tail cone section. It supports the horizontal stabilator, intermediate gearbox, tail gearbox, connecting tail rotor drive shaft, tail rotor assembly, and part of the flight controls. See figure 2-21.

- Q2-1. How many principal structural units are there in a fixed-wing aircraft?
- Q2-2. On a semimonocoque fuselage, what component absorbs the primary bending loads?
- Q2-3. What aircraft structure is designed to transmit engine loads, stresses, and vibrations to the aircraft structure?
- Q2-4. What is the main structural member of a wing assembly?

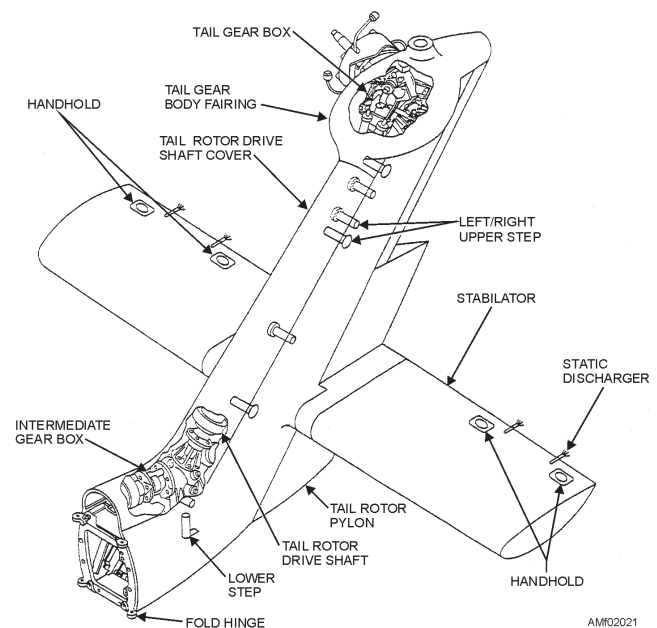

Figure 2-21.—H-60 tail pylon.

- Q2-5. What is the primary purpose of a stabilizer?
- Q2-6. What type of flight controls provides control over pitch, roll, and yaw?
- Q2-7. What flight control is operated by a side-to-side movement of the control stick?
- Q2-8. What type of flight control system is used on aircraft that travel at or near supersonic speeds?
- Q2-9. What flight control provides lateral control?
- Q2-10. What flight control provides longitudinal control?
- Q2-11. When is the mechanical control of an F-14 wing sweep used?
- Q2-12. Trim tabs, wing flaps, and speed brakes are all considered what type of flight controls?
- Q2-13. What is the main purpose of a speed brake?
- Q2-14. What type of shock strut is used on all naval aircraft?
- Q2-15. What component of a nose landing gear resists sudden twisting loads that are applied to the nosewheel during ground operation?
- Q2-16. What force is used to raise the arresting hook of an aircraft?
- Q2-17. What component of a catapult system allows the aircraft to be secured to the carrier deck?
- Q2-18. What is the major advantage of a helicopter over a fixed-wing aircraft?
- Q2-19. Most Navy helicopters have what fuselage design?

STRUCTURAL STRESS

LEARNING OBJECTIVES: Identify the five basic stresses acting on an aircraft.

Primary factors in aircraft structures are strength, weight, and reliability. These three factors determine the requirements to be met by any material used in airframe construction and repair. Airframes must be strong and light in weight. An aircraft built so heavy that it could not support more than a few hundred pounds of additional weight would be useless. In addition to having a good strength-to-weight ratio, all materials must be thoroughly reliable. This reliability minimizes the possibility of dangerous and unexpected failures.

TYPES OF STRESS

Numerous forces and structural stresses act on an aircraft when it is flying and when it is static. When it is static, gravity force alone produces weight. The weight is supported by the landing gear. The landing gear also absorbs the forces imposed during takeoffs and landings.

During flight, any maneuver that causes acceleration or deceleration increases the forces and stresses on the wings and fuselage. These loads are tension, compression, shear, bending, and torsion stresses. These stresses are absorbed by each component of the wing structure and transmitted to the fuselage structure. The empennage, or tail section, absorbs the same stresses and also transmits them to the fuselage structure. The study of such loads is called a “stress analysis.” The stresses must be analyzed and considered when an aircraft is designed. These stresses are shown in figure 2-22.

Tension

Tension may be defined as “pull.” It is the stress of stretching an object or pulling at its ends. An elevator control cable is in additional tension when the pilot moves the control column. Tension is the resistance to pulling apart or stretching, produced by two forces pulling in opposite directions along the same straight line.

Compression

If forces acting on an aircraft move toward each other to squeeze the material, the stress is called compression. Compression is the opposite of tension. Tension is a “pull,” and compression is a “push.” Compression is the resistance to crushing, produced by two forces pushing toward each other in the same

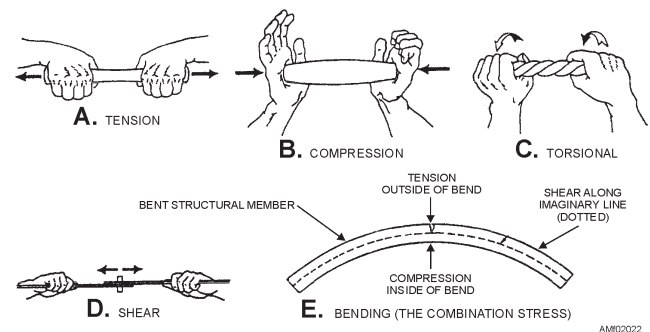

Figure 2-22.—Five stresses acting on an aircraft.

straight line. While an airplane is on the ground, the landing gear struts are under a constant compression stress.

Shear

Cutting a piece of paper with a pair of scissors is an example of shearing action. Shear in an aircraft structure is a stress exerted when two pieces of fastened material tend to separate. Shear stress is the outcome of sliding one part over the other in opposite directions. The rivets and bolts in an aircraft experience both shear and tension stresses.

Bending

Bending is a combination of tension and compression. Consider the bending of an object such as a piece of tubing. The upper portion stretches (tension) and the lower portion crushes together (compression). The wing spars of an aircraft in flight undergo bending stresses.

Torsion

Torsional stresses are the result of a twisting force. When you wring out a chamois skin, you are putting it under torsion. Torsion is produced in an engine crankshaft while the engine is running. Forces that cause torsional stresses produce torque.

VARYING STRESS

All materials are somewhat elastic. A rubberband is extremely elastic, whereas a piece of metal is not very elastic. All the structural members of an aircraft experience one or more stresses. Sometimes a structural member has alternate stresses. It is under compression one instant of time and under tension the next. The strength of aircraft materials must be great enough to withstand maximum force of varying stresses.

SPECIFIC ACTION OF STRESSES

You should understand the stresses encountered on the main parts of an aircraft. A knowledge of the basic stresses on aircraft structures helps you understand why aircraft are built the way they are. The fuselage of the aircraft encounters the five types of stress—torsion, bending, tension, shear, and compression.

Torsional stress in a fuselage is created in several ways. An example of this stress is encountered in engine torque on turboprop aircraft. Engine torque tends to rotate the aircraft in the direction opposite to that in which the propeller is turning. This force creates a torsional stress in the fuselage. Figure 2-23 shows the effect of the rotating propellers. Another example of torsional stress is the twisting force in the fuselage due to the action of the ailerons when the aircraft is maneuvered.

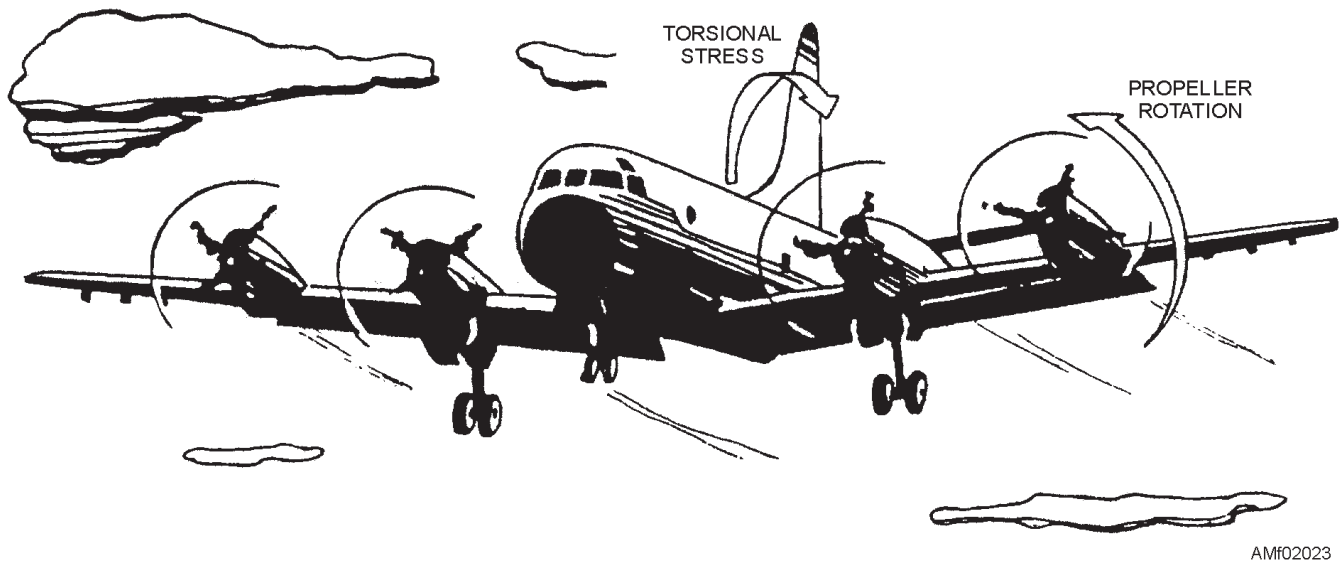

Figure 2-23.—Engine torque creates torsional stress in aircraft fuselages.

When an aircraft is on the ground, there is a bending force on the fuselage. This force occurs because of the weight of the aircraft itself. Bending greatly increases when the aircraft makes a carrier landing. This bending action creates a tension stress on the lower skin of the fuselage and a compression stress on the top skin. This bending action is shown in figure 2-24. These stresses are also transmitted to the fuselage when the aircraft is in flight. Bending occurs due to the reaction of the airflow against the wings and empennage. When the aircraft is in flight, lift forces act upward against the wings, tending to bend them upward. The wings are prevented from folding over the fuselage by the resisting strength of the wing structure. This bending action creates a tension stress on the bottom of the wings and a compression stress on the top of the wings.

- Q2-20. *What type of stress is produced by two forces pulling in opposite directions along the same straight line?*
- Q2-21. *What force is the opposite of tension?*
- Q2-22. *What type of stress is a combination of tension and compression?*
- Q2-23. *What type of stress is the result of a twisting force?*

MATERIALS OF CONSTRUCTION

LEARNING OBJECTIVES: Identify the various types of metallic and nonmetallic materials used in aircraft construction.

An aircraft requires materials that must be both light and strong. Early aircraft were made of wood. Lightweight metal alloys with a strength greater than

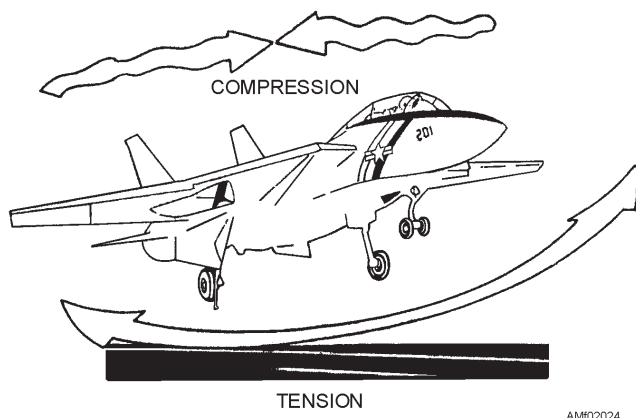

Figure 2-24.—Bending action occurring during carrier landing.

wood were developed and used on later aircraft. Materials currently used in aircraft construction may be classified as either metallic or nonmetallic.

METALLIC MATERIALS

The most common metals in aircraft construction are aluminum, magnesium, titanium, steel, and their alloys. Aluminum alloy is widely used in modern aircraft construction. It is vital to the aviation industry because the alloy has a high strength-to-weight ratio. Aluminum alloys are corrosion-resistant and comparatively easy to fabricate. The outstanding characteristic of aluminum is its lightweight.

Magnesium, the world's lightest structural metal, is a silvery-white material weighing only two-thirds as much as aluminum. Magnesium is used in the manufacture of helicopters. Magnesium's low resistance to corrosion has limited its use in conventional aircraft.

Titanium is a lightweight, strong, corrosion-resistant metal. It was discovered years ago, but only recently has it been made suitable for use in aircraft. Recent developments make titanium ideal for applications where aluminum alloys are too weak and stainless steel is too heavy. In addition, titanium is unaffected by long exposure to seawater and marine atmosphere.

An alloy is composed of two or more metals. The metal present in the alloy in the largest portion is called the base metal. All other metals added to the alloy are called alloying elements. Alloying elements, in either small or large amounts, may result in a marked change in the properties of the base metal. For example, pure aluminum is relatively soft and weak. When small amounts of other elements such as copper, manganese, and magnesium are added, aluminum's strength is increased many times. An increase or a decrease in an alloy's strength and hardness may be achieved through heat treatment of the alloy. Alloys are of great importance to the aircraft industry. Alloys provide materials with properties not possessed by a pure metal alone.

Alloy steels that are of much greater strength than those found in other fields of engineering have been developed. These steels contain small percentages of carbon, nickel, chromium, vanadium, and molybdenum. High-tensile steels will stand stresses of 50 to 150 tons per square inch without failing. Such steels are made into tubes, rods, and wires. Another type of steel that is used extensively is stainless steel. This alloy resists corrosion and is particularly valuable for use in or near salt water.

NONMETALLIC MATERIALS

In addition to metals, various types of plastic materials are found in aircraft construction. Transparent plastic is found in canopies, windshields, and other transparent enclosures. Handle transparent plastic surfaces with care, because this material is relatively soft and scratches easily. At approximately 225°F, transparent plastic becomes soft and very pliable.

Reinforced plastic is made for use in the construction of radomes, wing tips, stabilizer tips, antenna covers, and flight controls. Reinforced plastic has a high strength-to-weight ratio and is resistant to mildew and rot. Its ease of fabrication makes it equally suitable for other parts of the aircraft.

Reinforced plastic is a sandwich-type material. See figure 2-25. It is made up of two outer facings and a center layer. The facings are made up of several layers of glass cloth, bonded together with a liquid resin. The core material (center layer) consists of a honeycomb structure made of glass cloth. Reinforced plastic is fabricated into a variety of cell sizes.

High-performance aircraft require an extra high strength-to-weight ratio material. Fabrication of composite materials satisfies the special requirement. This construction method uses several layers of bonding materials (graphite epoxy or boron epoxy). These materials are mechanically fastened to conventional substructures. Another type of composite construction consists of thin graphite epoxy skins bonded to an aluminum honeycomb core.

Q2-24. What is the most widely used metal in modern aircraft construction?

Q2-25. What is the world's lightest structural metal?

Q2-26. At what temperature does transparent plastic become soft and pliable?

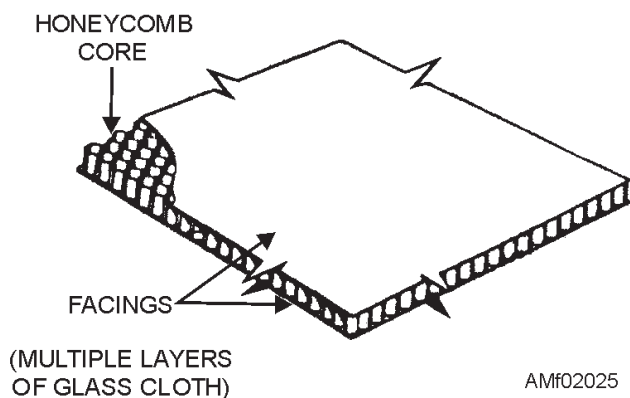

Figure 2-25.—Reinforced plastic.

Q2-27. Radomes, wing tips, stabilizer tips, and antenna covers are made from what type of plastic?

METALLIC MATERIALS

LEARNING OBJECTIVE: Identify the properties of metallic materials used in aircraft construction.

Metallurgists have been working for many years to improve metals for aircraft construction. Each metal has certain properties and characteristics that make it desirable for a particular application, but it may have other qualities that are undesirable. For example, some metals are hard, others comparatively soft; some are brittle, some tough; some can be formed and shaped without fracture; and some are so heavy that weight alone makes them unsuitable for aircraft use. The metallurgist's objectives are to improve the desirable qualities and tone down or eliminate the undesirable ones. This is done by alloying (combining) metals and by various heat-treating processes.

You do not have to be a metallurgist to be a good **AM**, but you should possess a knowledge and understanding of the uses, strengths, limitations, and other characteristics of aircraft structural metals. Such knowledge and understanding is vital to properly construct and maintain any equipment, especially airframes. In aircraft maintenance and repair, even a slight deviation from design specifications or the substitution of inferior materials may result in the loss of both lives and equipment. The use of unsuitable materials can readily erase the finest craftsmanship. The selection of the specific material for a specific repair job demands familiarity with the most common properties of various metals.

PROPERTIES OF METALS

This section is devoted primarily to the terms used in describing various properties and characteristics of metals in general. Your primary concerns in aircraft maintenance are such general properties of metals and their alloys as hardness, brittleness, malleability, ductility, elasticity, toughness, density, fusibility, conductivity, and contraction and expansion. You must know the definition of the terms included here because they form the basis for further discussion of aircraft metals.

Hardness

Hardness refers to the ability of a metal to resist abrasion, penetration, cutting action, or permanent

distortion. Hardness may be increased by working the metal and, in the case of steel and certain titanium and aluminum alloys, by heat treatment and cold-working (discussed later). Structural parts are often formed from metals in their soft state and then heat treated to harden them so that the finished shape will be retained. Hardness and strength are closely associated properties of all metals.

Brittleness

Brittleness is the property of a metal that allows little bending or deformation without shattering. In other words, a brittle metal is apt to break or crack without change of shape. Because structural metals are often subjected to shock loads, brittleness is not a very desirable property. Cast iron, cast aluminum, and very hard steel are brittle metals.

Malleability

A metal that can be hammered, rolled, or pressed into various shapes without cracking or breaking or other detrimental effects is said to be malleable. This property is necessary in sheet metal that is to be worked into curved shapes such as cowlings, fairings, and wing tips. Copper is one example of a malleable metal.

Ductility

Ductility is the property of a metal that permits it to be permanently drawn, bent, or twisted into various shapes without breaking. This property is essential for metals used in making wire and tubing. Ductile metals are greatly preferred for aircraft use because of their ease of forming and resistance to failure under shock loads. For this reason, aluminum alloys are used for cowl rings, fuselage and wing skin, and formed or extruded parts, such as ribs, spars, and bulkheads. Chrome-molybdenum steel is also easily formed into desired shapes. Ductility is similar to malleability.

Elasticity

Elasticity is that property that enables a metal to return to its original shape when the force that causes the change of shape is removed. This property is extremely valuable, because it would be highly undesirable to have a part permanently distorted after an applied load was removed. Each metal has a point known as the **elastic limit**, beyond which it cannot be loaded without causing permanent distortion. When metal is loaded beyond its elastic limit and permanent

distortion does result, it is referred to as **strained**. In aircraft construction, members and parts are so designed that the maximum loads to which they are subjected will never stress them beyond their elastic limit.

NOTE: Stress is the internal resistance of any metal to distortion.

Toughness

A material that possesses toughness will withstand tearing or shearing and may be stretched or otherwise deformed without breaking. Toughness is a desirable property in aircraft metals.

Density

Density is the weight of a unit volume of a material. In aircraft work, the actual weight of a material per cubic inch is preferred, since this figure can be used in determining the weight of a part before actual manufacture. Density is an important consideration when choosing a material to be used in the design of a part and still maintain the proper weight and balance of the aircraft.

Fusibility

Fusibility is defined as the ability of a metal to become liquid by the application of heat. Metals are fused in welding. Steels fuse at approximately 2,500°F, and aluminum alloys at approximately 1,110°F.

Conductivity

Conductivity is the property that enables a metal to carry heat or electricity. The heat conductivity of a metal is especially important in welding, because it governs the amount of heat that will be required for proper fusion. Conductivity of the metal, to a certain extent, determines the type of jig to be used to control expansion and contraction. In aircraft, electrical conductivity must also be considered in conjunction with bonding, which is used to eliminate radio interference. Metals vary in their capacity to conduct heat. Copper, for instance, has a relatively high rate of heat conductivity and is a good electrical conductor.

Contraction and Expansion

Contraction and expansion are reactions produced in metals as the result of heating or cooling. A high degree of heat applied to a metal will cause it to expand

or become larger. Cooling hot metal will shrink or contract it. Contraction and expansion affect the design of welding jigs, castings, and tolerances necessary for hot-rolled material.

QUALITIES OF METALS

The selection of proper materials is a primary consideration in the development of an airframe and in the proper maintenance and repair of aircraft. Keeping in mind the general properties of metals, it is now possible to consider the specific requirements that metals must meet to be suitable for aircraft purposes.

Strength, weight, and reliability determine the requirements to be met by any material used in airframe construction and repair. Airframes must be strong and as light in weight as possible. There are very definite limits to which increases in strength can be accompanied by increase in weight. An aircraft so heavy that it could not support more than a few hundred pounds of additional weight would be of little use. All metals, in addition to having a good strength/weight ratio, must be thoroughly reliable, thus minimizing the possibility of dangerous and unexpected failures. In addition to these general properties, the material selected for definite application must possess specific qualities suitable for the purpose. These specific qualities are strength, weight, corrosive properties, working properties, joining properties, and shock and fatigue properties.

Strength

The material must possess the strength required by the demands of dimensions, weight, and use. There are five basic stresses that metals may be required to withstand. These are tension, compression, shear, bending, and torsion.

Weight

The relationship between the strength of a material and its weight per cubic inch, expressed as a ratio, is known as the strength/weight ratio. This ratio forms the basis of comparing the desirability of various materials for use in airframe construction and repair. Neither strength nor weight alone can be used as a means of true comparison. In some applications, such as the skin of monocoque structures, thickness is more important than strength; and in this instance, the material with the lightest weight for a given thickness or gauge is best. Thickness or bulk is necessary to prevent buckling or damage caused by careless handling.

Corrosive Properties

Corrosion is the eating away or pitting of the surface or the internal structure of metals. Because of the thin sections and the safety factors used in aircraft design and construction, it would be dangerous to select a material subject to severe corrosion if it were not possible to reduce or eliminate the hazard. Corrosion can be reduced or prevented by using better grades of base metals; by coating the surfaces with a thin coating of paint, tin, chromium, or cadmium; or by an electrochemical process called "anodizing." Corrosion control is discussed at length in *Aviation Maintenance Ratings Fundamentals*, and it is not covered in detail in this course.

Working Properties

Another significant factor to consider in the selection of metals for aircraft maintenance and repair is the ability of material to be formed, bent, or machined to required shapes. The hardening of metals by cold-working or forming is called **work hardening**. If a piece of metal is formed (shaped or bent) while cold, it is said to be cold-worked. Practically all the work you do on metal is cold-work. While this is convenient, it causes the metal to become harder and more brittle.

If the metal is cold-worked too much (that is, if it is bent back and forth or hammered at the same place too often), it will crack or break. Usually, the more malleable and ductile a metal is, the more cold-working it can withstand.

Joining Properties

Joining metals structurally by welding, brazing, or soldering, or by such mechanical means as riveting or bolting, is a tremendous help in design and fabrication. When all other properties are equal, material that can be welded has the advantage.

Shock and Fatigue Properties

Aircraft metals are subject to both shock and fatigue (vibration) stresses. Fatigue occurs in materials that are exposed to frequent reversals of loading or repeatedly applied loads, if the fatigue limit is reached or exceeded. Repeated vibration or bending will ultimately cause a minute crack to occur at the weakest point. As vibration or bending continues, the crack lengthens until complete failure of the part occurs. This is termed "shock and fatigue failure." Resistance to this

condition is known as shock and fatigue resistance. It is essential that materials used for critical parts be resistant to these stresses.

The preceding discussion of the properties and qualities of metals is intended to show why you must know which traits in metals are desirable and which are undesirable to do certain jobs. The more you know about a given material, the better you can handle airframe repairs.

METAL WORKING PROCESSES

When metal is not cast in a desired manner, it is formed into special shapes by mechanical working processes. Several factors must be considered when determining whether a desired shape is to be cast or formed by mechanical working. If the shape is very complicated, casting will be necessary to avoid expensive machining of mechanically formed parts. On the other hand, if strength and quality of material are the prime factors in a given part, a cast will be unsatisfactory. For this reason, steel castings are seldom used in aircraft work.

There are three basic methods of metal working. They are hot-working, cold-working, and extruding. The process chosen for a particular application depends upon the metal involved and the part required, although in some instances you might employ both hot- and cold-working methods in making a single part.

Hot-Working

Almost all steel is hot-worked from the ingot into some form from which it is either hot- or cold-worked to the finished shape. When an ingot is stripped from its mold, its surface is solid, but the interior is still molten. The ingot is then placed in a soaking pit, which retards loss of heat, and the molten interior gradually solidifies. After soaking, the temperature is equalized throughout the ingot, which is then reduced to intermediate size by rolling, making it more readily handled.

The rolled shape is called a bloom when its sectional dimensions are 6 x 6 inches or larger and approximately square. The section is called a billet when it is approximately square and less than 6 times 6 inches. Rectangular sections that have width greater than twice the thickness are called "slabs." The slab is the intermediate shape from which sheets are rolled.

HOT-ROLLING.—Blooms, billets, or slabs are heated above the critical range and rolled into a variety of shapes of uniform cross section. The more common

of these rolled shapes are sheets, bars, channels, angles, I-beams, and the like. In aircraft work, sheets, bars, and rods are the most commonly used items that are rolled from steel. Hot-rolled materials are frequently finished by cold-rolling or drawing to obtain accurate finish dimensions and a bright, smooth surface.

FORGING.—Complicated sections that cannot be rolled, or sections of which only a small quantity is required, are usually forged. Forging of steel is a mechanical working of the metal above the critical range to shape the metal as desired. Forging is done either by pressing or hammering the heated steel until the desired shape is obtained.

Pressing is used when the parts to be forged are large and heavy, and this process also replaces hammering where high-grade steel is required. Since a press is slow acting, its force is uniformly transmitted to the center of the section, thus affecting the interior grain structure as well as the exterior to give the best possible structure throughout.

Hammering can be used only on relatively small pieces. Since hammering transmits its force almost instantly, its effect is limited to a small depth. Thus, it is necessary to use a very heavy hammer or to subject the part to repeated blows to ensure complete working of the section. If the force applied is too weak to reach the center, the finished forging surface will be concave. If the center is properly worked, the surface will be convex or bulged. The advantage of hammering is that the operator has control over the amount of pressure applied and the finishing temperature, and is able to produce parts of the highest grade.

This type of forging is usually referred to as smith forging, and it is used extensively where only a small number of parts are needed. Considerable machining and material are saved when a part is smith forged to approximately the finished shape.

Cold-Working

Cold-working applies to mechanical working performed at temperatures below the critical range, and results in a strain hardening of the metal. It becomes so hard that it is difficult to continue the forming process without softening the metal by annealing.

Since the errors attending shrinkage are eliminated in cold-working, a much more compact and better metal is obtained. The strength and hardness as well as the elastic limit are increased, but the ductility decreases. Since this makes the metal more brittle, it

must be heated from time to time during certain operations to remove the undesirable effects of the working.

While there are several cold-working processes, the two with which you are principally concerned are cold-rolling and cold-drawing. These processes give the metals desirable qualities that cannot be obtained by hot-working.

COLD-ROLLING.—Cold-rolling usually refers to the working of metal at room temperature. In this operation, the materials that have been hot-rolled to approximate sizes are pickled to remove any scale, after which they are passed through chilled finished rolls. This action gives a smooth surface and also brings the pieces to accurate dimensions. The principal forms of cold-rolled stocks are sheets, bars, and rods.

COLD-DRAWING.—Cold-drawing is used in making seamless tubing, wire, streamline tie rods, and other forms of stock. Wire is made from hot-rolled rods of various diameters. These rods are pickled in acid to remove scale, dipped in lime water, and then dried in a steam room, where they remain until ready for drawing. The lime coating adhering to the metal serves as a lubricant during the drawing operation. Figure 2-26 shows the drawing of rod, tubing, and wire.

The size of the rod used for drawing depends upon the diameter wanted in the finished wire. To reduce the rod to the desired wire size, it is drawn cold through a die. One end of the rod is filed or hammered to a point and slipped through the die opening, where it is gripped by the jaws of the draw, then pulled through the die. This series of operations is done by a mechanism known as the draw bench, as shown in figure 2-26.

To reduce the rod gradually to the desired size, it is necessary to draw the wire through successively smaller dies. Because each of these drawings reduces the ductility of the wire, it must be annealed from time to time before further drawings can be accomplished. Although cold-working reduces the ductility, it increases the tensile strength of the wire enormously.

In making seamless steel aircraft tubing, the tubing is cold-drawn through a ring-shaped die with a mandrel or metal bar inside the tubing to support it while the drawing operations are being performed. This forces the metal to flow between the die and the mandrel and affords a means of controlling the wall thickness and the inside and outside diameters.

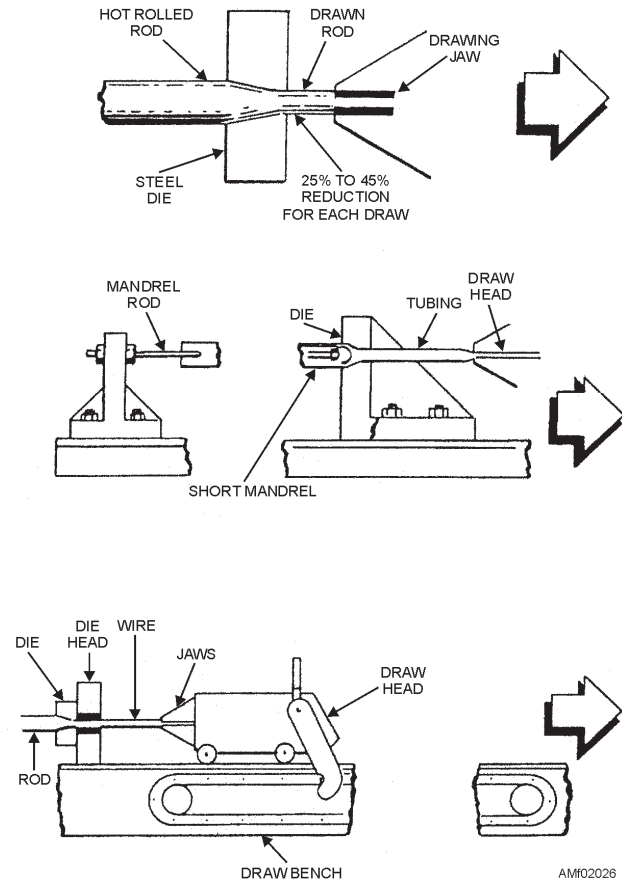

Figure 2-26.—Cold drawing operation for rods, tubing, and wire.

Extruding

The extrusion process involves the forcing of metal through an opening in a die, thus causing the metal to take the shape of the die opening. Some metals such as lead, tin, and aluminum may be extruded cold; but generally, metals are heated before the operation is begun.

The principal advantage of the extrusion process is in its flexibility. Aluminum, because of its workability and other favorable properties, can be economically extruded to more intricate shapes and larger sizes than is practicable with many other metals. Extruded shapes are produced in very simple as well as extremely complex sections.

A cylinder of aluminum, for instance, is heated to 750°F to 850°F, and is then forced through the opening of a die by a hydraulic ram. Many structural parts, such as stringers, are formed by the extrusion process.

ALLOYING OF METALS

A substance that possesses metallic properties and is composed of two or more chemical elements, of which at least one is a metal, is called an “alloy.” The metal present in the alloy in the largest proportion is called the “base metal.” All other metals and/or elements added to the alloy are called “alloying elements.” The metals are dissolved in each other while molten, and they do not separate into layers when the solution solidifies. Practically all the metals used in aircraft are made up of a number of alloying elements.

Alloying elements, either in small or in large amounts, may result in a marked change in the properties of the base metal. For example, pure aluminum is a relatively soft and weak metal, but by adding small amounts of other elements such as copper, manganese, magnesium, and zinc, its strength can be increased many times. Aluminum containing such other elements purposely added during manufacture is called an aluminum alloy.

In addition to increasing the strength, alloying may change the heat-resistant qualities of a metal, its corrosion resistance, electrical conductivity, or magnetic properties. It may cause an increase or decrease in the degree to which hardening occurs after cold-working. Alloying may also make possible an increase or decrease in strength and hardness by heat treatment. Alloys are of great importance to the aircraft industry in providing materials with properties that pure metals alone do not possess.

FERROUS AIRCRAFT METALS

Many types of materials are required in the repair of aircraft. This is a result of the varying needs with respect to strength, weight, durability, and resistance to deterioration of specific structures or parts. In addition, the particular shape or form of the material plays an important role. In selecting materials for aircraft repair, these factors, plus many others, are considered in relation to their mechanical and physical properties. Among the common materials used are ferrous metals. The term *ferrous* applies to the group of metals having iron as their principal constituent.

Identification

If carbon is added to iron, in percentages ranging up to approximately 1.00 percent, the product will be vastly superior to iron alone and is classified as carbon steel. Carbon steel forms the base of those alloy steels

produced by combining carbon with other elements known to improve the properties of steel. A base metal (such as iron) to which small quantities of other metals have been added is called an alloy. The addition of other metals is to change or improve the chemical or physical properties of the base metal.

SAE NUMERICAL INDEX.—The steel classification of the Society of Automotive Engineers (SAE) is used in specifications for all high-grade steels used in automotive and aircraft construction. A numerical index system identifies the composition of SAE steels. Each SAE number consists of a group of digits, the first of which represents the type of steel; the second, the percentage of the principal alloying element; and usually the last two or three digits, the percentage, in hundredths of 1 percent, of carbon in the alloy. For example, the SAE number 4150 indicates a molybdenum steel containing 1 percent molybdenum and 50 hundredths of 1 percent of carbon. Refer to the SAE numerical index, shown in table 2-1, to see how the various types of steel are classified into four-digit classification numbers.

Table 2-1.—SAE Numerical Index

Type of steel	Classification
Carbon	1xxx
Nickel	2xxx
Nickel-chromium	3xxx
Molybdenum	4xxx
Chromium	5xxx
Chromium-vanadium	6xxx
Tungsten	7xxx
Silicon-manganese	9xxx

HARDNESS TESTING METHODS.—Hardness testing is a factor in the determination of the results of heat treatment as well as the condition of the metal before heat treatment. There are two commonly used methods of hardness testing, the Brinell and the Rockwell tests. These tests require the use of specific machines and are covered later in this chapter. An additional, and somewhat indirect, method known as spark testing is used in identifying ferrous metals. This type of identification gives an indication of the hardness of the metal.

Spark testing is a common means of identifying ferrous metals that have become mixed. In this test, the piece of iron or steel is held against a revolving stone, and the metal is identified by the sparks thrown off. Each ferrous metal has its own peculiar spark

characteristics. The spark streams vary from a few tiny shafts to a shower of sparks several feet in length. Few nonferrous metals give off sparks when touched to a grinding stone. Therefore, these metals cannot be successfully identified by the spark test.

Wrought iron produces long shafts that are a dull red color as they leave the stone, and they end up a white color. Cast iron sparks are red as they leave the stone, but turn to a straw color. Low-carbon steels give off long, straight shafts that have a few white sprigs. As the carbon content of the steel increases, the number of sprigs along each shaft increases, and the stream becomes whiter in color. Nickel steel causes the spark stream to contain small white blocks of light within the main burst.

Types, Characteristics, and Uses of Alloyed Steels

While the plain carbon type of steel remains the principal product of the steel mills, so-called alloy or special steels are being turned out in ever increasing tonnage. Let us now consider those alloyed steels and their uses in aircraft.

CARBON STEELS.—Steel containing carbon in percentages ranging from 0.10 to 0.30 percent are classed as low-carbon steel. The equivalent SAE numbers range from 1010 to 1030. Steels of this grade are used for making such items as safety wire, certain nuts, cable bushings, and threaded rod ends. Low-carbon steel in sheet form is used for secondary structural parts and clamps, and in tubular form for moderately stressed structural parts.

Steels containing carbon in percentages ranging from 0.30 to 0.50 percent are classed as medium-carbon steel. This steel is especially adaptable for machining or forging and where surface hardness is desirable. Certain rod ends and light forgings are made from SAE 1035 steel.

Steel containing carbon in percentages ranging from 0.50 to 1.05 percent are classed as high-carbon steel. The addition of other elements in varying quantities adds to the hardness of this steel. In the fully heat-treated condition, it is very hard and will withstand high shear and wear and have little deformation. It has limited use in aircraft. SAE 1095 in sheet form is used for making flat springs, and in wire form for making coil springs.

NICKEL STEELS.—The various nickel steels are produced by combining nickel with carbon steel. Steels containing from 3 to 3.75 percent nickel are

commonly used. Nickel increases the hardness, tensile strength, and elastic limit of steel without appreciably decreasing the ductility. It also intensifies the hardening effect of heat treatment. SAE 2330 steel is used extensively for aircraft parts such as bolts, terminals, keys, clevises, and pins.

CHROMIUM STEELS.—Chromium steels are high in hardness, strength, and corrosion-resistant properties. SAE 51335 is particularly adaptable for heat-treated forgings that require greater toughness and strength than may be obtained in plain carbon steel. It is used for such articles as the balls and rollers of antifriction bearings.

CHROMIUM-NICKEL OR STAINLESS STEELS.—These are corrosion-resisting metals. The anticorrosive degree is determined by the surface condition of the metal as well as by the composition, temperature, and concentration of the corrosive agent.

The principal part of stainless steel is chromium, to which nickel may or may not be added. The corrosion-resisting steel most often used in aircraft construction is known as 18-8 steel because of its content of 18 percent chromium and 8 percent nickel. One of the distinctive features of 18-8 steel is that its strength may be increased by cold-working.

Stainless steel may be rolled, drawn, bent, or formed to any shape. Because these steels expand about 50 percent more than mild steel and conduct heat only about 40 percent as rapidly, they are more difficult to weld. Stainless steel, with but a slight variation in its chemical composition, can be used for almost any part of an aircraft. Some of its more common applications are in the fabrication of exhaust collectors, stacks and manifolds, structural and machined parts, springs, castings, and tie rods and cables.

CHROME-VANADIUM STEELS.—These are made of approximately 0.18 percent vanadium and about 1.00 percent chromium. When heat-treated, they have strength, toughness, and resistance to wear and fatigue. A special grade of this steel in sheet form can be cold-formed into intricate shapes. It can be folded and flattened without signs of breaking or failure. SAE 6150 is used for making springs; and chrome-vanadium with high-carbon content, SAE 6195, is used for ball and roller bearings.

CHROME-MOLYBDENUM STEELS.—Molybdenum in small percentages is used in combination with chromium to form chrome-molybdenum steel, which has various uses in aircraft. Molybdenum is a strong alloying element, only 0.15 to 0.25 percent

being used in the chrome-molybdenum steels; the chromium content varies from 0.80 to 1.10 percent. Molybdenum raises the ultimate strength of steel without affecting ductility or workability. Molybdenum steels are tough, wear resistant, and harden throughout from heat treatment. They are especially adaptable for welding, and for this reason are used principally for welded structural parts and assemblies. SAE 4130 is used for parts such as engine mounts, nuts, bolts, gear structures, support brackets for accessories, and other structural parts.

The progress of jet propulsion in the field of naval aviation has been aided by the continuous research in high-temperature metallurgy. This research has brought forth alloys to withstand the high temperatures and velocities encountered in jet power units. These alloys are chemically similar to the previously mentioned steels, but may also contain cobalt, copper, and columbium in varied amounts as alloying elements.

NONFERROUS AIRCRAFT METALS

The term *nonferrous* refers to all metals that have elements other than iron as their principal constituent. This group includes aluminum, titanium, copper, magnesium, and their alloys; and in addition, such alloy metals as Monel and Babbitt.

Aluminum and Aluminum Alloys

Commercially pure aluminum is a white, lustrous metal, light in weight and corrosion resistant. Aluminum combined with various percentages of other metals (generally copper, manganese, magnesium, and chromium) form the alloys that are used in aircraft construction. Aluminum alloys in which the principal alloying ingredients are either manganese, magnesium, or chromium, or magnesium and silicon, show little attack in corrosive environments. On the other hand, those alloys in which substantial percentages of copper are used are more susceptible to corrosive action. The total percentage of alloying elements is seldom more than 6 or 7 percent in the wrought aluminum alloys.

TYPES, CHARACTERISTICS, AND USES.—Aluminum is one of the most widely used metals in modern aircraft construction. It is vital to the aviation industry because of its high strength/weight ratio, its corrosion-resisting qualities, and its comparative ease of fabrication. The outstanding characteristic of aluminum is its light weight. In color, aluminum resembles silver, although it possesses a characteristic bluish tinge of its own. Commercially pure aluminum

melts at the comparatively low temperature of 1,216°F. It is nonmagnetic, and is an excellent conductor of electricity.

Commercially pure aluminum has a tensile strength of about 13,000 psi, but by rolling or other cold-working processes, its strength may be approximately doubled. By alloying with other metals, together with the use of heat-treating processes, the tensile strength may be raised to as high as 96,000 psi, or to well within the strength range of structural steel.

Aluminum alloy material, although strong, is easily worked, for it is very malleable and ductile. It may be rolled into sheets as thin as 0.0017 inch or drawn into wire 0.004 inch in diameter. Most aluminum alloy sheet stock used in aircraft construction ranges from 0.016 to 0.096 inch in thickness; however, some of the larger aircraft use sheet stock that may be as thick as 0.0356 inch.

One disadvantage of aluminum alloy is the difficulty of making reliable soldered joints. Oxidation of the surface of the heated metal prevents soft solder from adhering to the material; therefore, to produce good joints of aluminum alloy, a riveting process is used. Some aluminum alloys are also successfully welded.

The various types of aluminum may be divided into two classes—casting alloys (those suitable for casting in sand, permanent mold, and die castings) and the wrought alloys (those that may be shaped by rolling, drawing, or forging). Of the two, the wrought alloys are the most widely used in aircraft construction, being used for stringers, bulkheads, skin, rivets, and extruded sections. Casting alloys are not extensively used in aircraft.

WROUGHT ALLOYS.—Wrought alloys are divided into two classes—nonheat treatable and heat treatable. In the nonheat-treatable class, strain hardening (cold-working) is the only means of increasing the tensile strength. Heat-treatable alloys may be hardened by heat treatment, by cold-working, or by the application of both processes.

Aluminum products are identified by a universally used designation system. Under this arrangement, wrought aluminum and wrought aluminum alloys are designated by a four-digit index system.

The first digit of the designation indicates the major alloying element or alloy group, as shown in table 2-2. The 1xxx indicates aluminum of 99.0 percent or greater; 2xxx indicates an aluminum alloy in which

Table 2-2.—Designation for Aluminum Alloy Groups

Aluminum—99.0 percent minimum and greater	1xxx
Aluminum alloys, grouped by major alloying element:	
Copper	2xxx
Manganese	3xxx
Silicon	4xxx
Magnesium	5xxx
Magnesium and silicon	6xxx
Zinc	7xxx
Other elements	8xxx

copper is the major alloying element; 3xxx indicates an aluminum alloy with manganese as the major alloying element; etc. Although most aluminum alloys contain several alloying elements, only one group (6xxx) designates more than one alloying element.

In the 1xxx group, the second digit in the designation indicates modifications in impurity limits. If the second digit is zero, it indicates that there is no special control on individual impurities. The last two of the four digits indicate the minimum aluminum percentage. Thus, alloy 1030 indicates 99.30 percent aluminum without special control on impurities. Alloys 1130, 1230, 1330, etc., indicate the same aluminum purity with special control on one or more impurities. Likewise, 1075, 1175, 1275, etc., indicate 99.75 percent aluminum.

In the 2xxx through 8xxx groups, the second digit indicates alloy modifications. If the second digit in the designation is zero, it indicates the original alloy, while numbers 1 through 9, assigned consecutively, indicate alloy modifications. The last two of the four digits have no special significance, but serve only to identify the different alloys in the group.

The temper designation follows the alloy designation and shows the actual condition of the metal. It is always separated from the alloy designation by a dash.

The letter *F* following the alloy designation indicates the “as fabricated” condition, in which no effort has been made to control the mechanical properties of the metal.

The letter *O* indicates dead soft, or annealed, condition.

The letter *W* indicates solution heat treated. Solution heat treatment consists of heating the metal to a high temperature followed by a rapid quench in cold water. This is an unstable temper, applicable only to those alloys that spontaneously age at room temperature. Alloy 7075 may be ordered in the *W* condition.

The letter *H* indicates strain hardened, cold-worked, hand-drawn, or rolled. Additional digits are added to the *H* to indicate the degree of strain hardening. Alloys in this group cannot be strengthened by heat treatment, hence the term *nonheat-treatable*.

The letter *T* indicates fully heat treated. Digits are added to the *T* to indicate certain variations in treatment.

Greater strength is obtainable in the heat-treatable alloys. They are often used in aircraft in preference to the nonheat-treatable alloys. Heat-treatable alloys commonly used in aircraft construction (in order of increasing strength) are 6061, 6062, 6063, 2017, 2024, 2014, 7075, and 7178.

Alloys 6061, 6062, and 6063 are sometimes used for oxygen and hydraulic lines and in some applications as extrusions and sheet metal.

Alloy 2017 is used for rivets, stressed-skin covering, and other structural members.

Alloy 2024 is used for airfoil covering and fittings. It may be used wherever 2017 is specified, since it is stronger.

Alloy 2014 is used for extruded shapes and forgings. This alloy is similar to 2017 and 2024 in that it contains a high percentage of copper. It is used where

more strength is required than that obtainable from 2017 or 2024.

Alloy 7178 is used where highest strength is necessary. Alloy 7178 contains a small amount of chromium as a stabilizing agent, as does alloy 7075.

Nonheat-treatable alloys used in aircraft construction are 1100, 3003, and 5052. These alloys do not respond to any heat treatment other than a softening, annealing effect. They may be hardened only by cold-working.

Alloy 1100 is used where strength is not an important factor, but where weight, economy, and corrosion resistance are desirable. This alloy is used for fuel tanks, fairings, oil tanks, and for the repair of wing tips and tanks.

Alloy 3003 is similar to 1100 and is generally used for the same purposes. It contains a small percentage of manganese and is stronger and harder than 1100, but retains enough work ability that it is usually preferred over 1100 in most applications.

Alloy 5052 is used for fuel lines, hydraulic lines, fuel tanks, and wing tips. Substantially higher strength without too much sacrifice of workability can be obtained in 5052. It is preferred over 1100 and 3003 in many applications.

Alclad is the name given to standard aluminum alloys that have been coated on both sides with a thin layer of pure aluminum. Alclad has very good corrosion-resisting qualities and is used exclusively for exterior surfaces of aircraft. Alclad sheets are available in all tempers of 2014, 2017, 7075, and 7178.

CASTING ALLOYS.—Aluminum casting alloys, like wrought alloys, are divided into two groups. In one group, the physical properties of the alloys are determined by the elements added and cannot be changed after the metal is cast. In the other group, the elements added make it possible to heat-treat the casting to produce desired physical properties.

The casting alloys are identified by a letter preceding the alloy number. This is exactly opposite from the case of wrought alloys, in which the letters follow the number. When a letter precedes a number, it indicates a slight variation in the composition of the original alloy. This variation in composition is made simply to impart some desirable quality. In casting alloy 214, for example, the addition of zinc, to increase its pouring qualities, is designated by the letter *A* in front of the number, thus creating the designation A214.

When castings have been treated, the heat treatment and the composition of the casting are indicated by the letter *T* and an alloying number. An example of this is the sand casting alloy 355, which has several different compositions and tempers and is designated by 355-T6, 355-T51, and A355-T51.

Aluminum alloy castings are produced by one of three basic methods—sand mold, permanent mold, and die cast. In casting aluminum, in most cases, different types of alloys must be used for different types of castings. Sand castings and die castings require different types of alloys than those used in permanent molds.

SHOP CHARACTERISTICS OF ALUMINUM ALLOYS.—Aluminum is one of the most readily workable of all the common commercial metals. It can be fabricated readily into a variety of shapes by any conventional method; however, formability varies a great deal with the alloy and temper.

In general, the aircraft manufacturers form the heat-treatable alloys in the -0 or -T4 condition before they have reached their full strength. They are subsequently heat-treated or aged to the maximum strength (-T6) condition before installation in aircraft. By this combination of processes, the advantage of forming in a soft condition is obtained without sacrificing the maximum obtainable strength/weight ratio.

Aluminum is one of the most readily weldable of all metals. The nonheat-treatable alloys can be welded by all methods, and the heat-treatable alloys can be successfully spot welded. The melting point for pure aluminum is 1,216°F, while various aluminum alloys melt at slightly lower temperatures. Aluminum products do not show any color changes when heated, even up to the melting point. Riveting is the most reliable method of joining stress-carrying parts of heat-treated aluminum alloy structures.

Titanium and Titanium Alloys

Titanium and titanium alloys are used chiefly for parts that require good corrosion resistance, moderate strength up to 600°F, and lightweight.

TYPES, CHARACTERISTICS, AND USES.—Titanium alloys are being used in quantity for jet engine compressor wheels, compressor blades, spacer rings, housing compartments, and airframe parts such as engine pads, ducting, wing surfaces, fire walls, fuselage skin adjacent to the engine outlet, and armor plate.

In view of titanium's high melting temperature, approximately 3,300°F, its high-temperature properties are disappointing. The ultimate and yield strengths of titanium drop fast above 800°F. In applications where the declines might be tolerated, the absorption of oxygen and nitrogen from the air at temperatures above 1,000°F makes the metal so brittle on long exposure that it soon becomes worthless. Titanium has some merit for short-time exposure up to 2,000°F where strength is not important, as in aircraft fire walls.

Sharp tools are essential in machining techniques because titanium has a tendency to resist or back away from the cutting edge of tools. It is readily welded, but the tendency of the metal to absorb oxygen, nitrogen, and hydrogen must never be ignored. Machine welding with an inert gas atmosphere has proven most successful.

Both commercially pure and alloy titanium can absorb large amounts of cold-work without cracking. Practically anything that can be deep drawn in low-carbon steel can be duplicated in commercially pure titanium, although the titanium may require more intermediate anneals.

IDENTIFICATION OF TITANIUM.—

Titanium metal, pure or alloyed, is easily identified. When touched with a grinding wheel, it makes white spark traces that end in brilliant white bursts. When rubbed with a piece of glass, moistened titanium will leave a dark line similar in appearance to a pencil mark.

Copper and Copper Alloys

Most commercial copper is refined to a purity of 99.9 percent minimum copper plus silver. It is the only reddish-colored metal, and it is second only to silver in electrical conductivity. Its use as a structural material is limited because of its great weight. However, some of its outstanding characteristics, such as its high electrical and heat conductivity, in many cases overbalance the weight factor.

Because it is very malleable and ductile, copper is ideal for making wire. In aircraft, copper is used primarily for the electrical system and for instrument tubing and bonding. It is corroded by salt water, but is not affected by fresh water. The ultimate tensile strength of copper varies greatly. For cast copper, the tensile strength is about 25,000 psi; and when cold-rolled or cold-drawn, its tensile strength increases, ranging from 40,000 to 67,000 psi.

BRASS.—Brass is a copper alloy containing zinc and small amounts of aluminum, iron, lead, manganese, magnesium, nickel, phosphorous, and tin. Brass with a zinc content of 30 to 35 percent is very ductile, while that containing 45 percent has relatively high strength. “Muntz metal” is a brass composed of 60 percent copper and 40 percent zinc. It has excellent corrosion-resistant qualities when in contact with salt water. Its strength can be increased by heat treatment. As cast, this metal has an ultimate tensile strength of 50,000 psi and can be elongated 18 percent. It is used in making bolts and nuts, as well as parts that come in contact with salt water. “Red brass,” sometimes termed *bronze* because of its tin content, is used in fuel and oil line fittings. This metal has good casting and finishing properties and machines freely.

BRONZES.—Bronzes are copper alloys containing tin. The true bronzes have up to 25 percent tin, but those below 11 percent are most useful, especially for such items as tube fittings in aircraft.

Among the copper alloys are the copper aluminum alloys, of which the aluminum bronzes rank very high in aircraft usage. They would find greater usefulness in structures if it were not for their strength/weight ratio as compared with alloy steels. Wrought aluminum bronzes are almost as strong and ductile as medium-carbon steel, and possess a high degree of resistance to corrosion by air, salt water, and chemicals. They are readily forged, hot- or cold-rolled, and some react to heat treatment.

These copper-based alloys contain up to 16 percent of aluminum (usually 5 to 11 percent) to which other metals such as iron, nickel, or manganese may be added. Aluminum bronzes have good tearing qualities, great strength, hardness, and resistance to both shock and fatigue. Because of these properties, they are used for diaphragms and gears, air pumps, condenser bolts, and slide liners. Aluminum bronzes are available in rods, bars, plates, sheets, strips, and forgings.

Cast aluminum bronzes, using about 89 percent copper, 9 percent aluminum, and 2 percent of other elements, have high strength combined with ductility, and are resistant to corrosion, shock, and fatigue. Because of these properties, cast aluminum bronze is used in gun mounts, bearings, and pump parts. These alloys are useful in areas exposed to salt water and corrosive gases.

Manganese bronze is an exceptionally high-strength, tough, corrosion-resistant copper zinc alloy containing aluminum, manganese, iron, and

occasionally nickel or tin. This metal can be formed, extruded, drawn, or rolled to any desired shape. In rod form, it is generally used for machined parts. Otherwise it is used in catapults, landing gears, and brackets.

Silicon bronze is composed of about 95 percent copper, 3 percent silicon, and 2 percent mixture of manganese, zinc, iron, tin, and aluminum. Although not a bronze in the true sense of the word because of its small tin content, silicon bronze has high strength and great corrosion resistance and is used variably.

BERYLLIUM COPPER.—Beryllium copper is one of the most successful of all the copper-based alloys. It is a recently developed alloy containing about 97 percent copper, 2 percent beryllium, and sufficient nickel to increase the percentage of elongation. The most valuable feature of this metal is that the physical properties can be greatly stepped up by heat treatment—the tensile strength rising from 70,000 psi in the annealed state to 200,000 psi in the heat-treated state. The resistance of beryllium copper to fatigue and wear makes it suitable for diaphragms, precision bearings and bushings, ball cages, spring washers, and nonsparking tools.

Monel

Monel, the leading high-nickel alloy, combines the properties of high strength and excellent corrosion resistance. This metal consists of 67 percent nickel, 30 percent copper, 1.4 percent iron, 1 percent manganese, and 0.15 percent carbon. It cannot be hardened by heat treatment; it responds only to cold-working.

Monel, adaptable to castings and hot- or cold-working, can be successfully welded and has working properties similar to those of steel. It has a tensile strength of 65,000 psi that, by means of cold-working, may be increased to 160,000 psi, thus entitling this metal to classification among the tough alloys. Monel has been successfully used for gears and chains, for operating retractable landing gears, and for structural parts subject to corrosion. In aircraft, Monel has long been used for parts demanding both strength and high resistance to corrosion, such as exhaust manifolds and carburetor needle valves and sleeves.

K-Monel

K-Monel is a nonferrous alloy containing mainly nickel, copper, and aluminum. It is produced by adding a small amount of aluminum to the Monel formula. It is corrosion resistant and capable of hardening by heat

treatment. K-Monel has been successfully used for gears, chains, and structural members in aircraft that are subjected to corrosive attacks. This alloy is nonmagnetic at all temperatures. K-Monel can be successfully welded.

Magnesium and Magnesium Alloys

Magnesium, the world's lightest structural metal, is a silvery-white material weighing only two-thirds as much as aluminum. Magnesium does not possess sufficient strength in its pure state for structural uses; but when it is alloyed with zinc, aluminum, and manganese, it produces an alloy having the highest strength/weight ratio.

Magnesium is probably more widely distributed in nature than any other metal. It can be obtained from such ores as dolomite and magnesite, from underground brines, from waste liquors of potash, and from seawater. With about 10 million pounds of magnesium in 1 cubic mile of seawater, there is no danger of a dwindling supply.

Magnesium is used extensively in the manufacture of helicopters. Its low resistance to corrosion has been a factor in reducing its use in conventional aircraft.

The machining characteristics of magnesium alloys are excellent. Usually the maximum speeds of machine tools can be used with heavy cuts and high feed rates. Power requirements for magnesium alloys are about one-sixth of those for mild steel. An excellent surface finish can be produced, and, in most cases, grinding is not essential. Standard machine operations can be performed to tolerances of a few ten-thousandths of an inch. There is no tendency of the metal to tear or drag.

Magnesium alloy sheets can be worked in much the same manner as other sheet metal with one exception—the metal must be worked while hot. The structure of magnesium is such that the alloys work harden rapidly at room temperatures. The work is usually done at temperatures ranging from 450°F to 650°F, which is a disadvantage. However, compensations are offered by the fact that in the ranges used, magnesium is more easily formed than other materials. Sheets can be sheared in much the same way as other metals, except that a rough flaky fracture is produced on sheets thicker than about 0.064 inch. A better edge will result on a sheet over 0.064 inch thick if it is sheared hot.

Annealed sheet can be heated to 600°F, but hard-rolled sheet should not be heated above 275°F. A

straight bend with a short radius can be made by the Guerin process, as shown in figure 2-27, or by press or leaf brakes. The Guerin process is the most widely used method for forming and shallow drawing, employing a rubber pad as the female die, which bends the work to the shape of the male die.

Magnesium alloys possess good casting characteristics. Their properties compare favorably with those of cast aluminum. In forging, hydraulic presses are ordinarily used; although, under certain conditions, forging can be accomplished in mechanical presses or with drop hammers.

Magnesium embodies fire hazards of an unpredictable nature. When in large sections, its high thermal conductivity makes it difficult to ignite and prevents its burning. It will not burn until the melting point is reached, which is approximately 1,200°F. However, magnesium dust and fine chips are ignited easily; precautions must be taken to avoid this if possible. If they are ignited, you should extinguish them immediately with an extinguishing powder such as powdered soapstone, clean, dry, unrusted cast iron chips, or graphite powder.

CAUTION

Water or any standard liquid or foam extinguisher causes magnesium to burn more rapidly and may cause small explosions.

SUBSTITUTION AND INTERCHANGEABILITY OF AIRCRAFT METALS

In selecting interchangeable or substitute materials for the repair and maintenance of naval aircraft, it is important that you check the appropriate aeronautic technical publications when specified materials are not in stock or not obtainable from another source. It is impossible to determine if another material is as strong as the original by mere observation. There are four requirements that you must keep in mind in this selection. The first and most important of these is maintaining the original strength of the structure. The other three are maintaining contour or aerodynamic smoothness, maintaining original weight, if possible, or keeping added weight to a minimum, and maintaining the original corrosive-resistant properties of the metal.

Because different manufacturers design structural members to meet various load requirements, you can

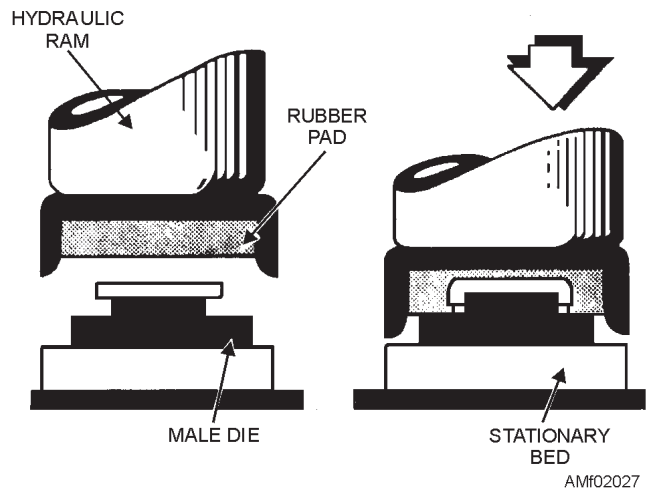

Figure 2-27.—Guerin process.

appreciate the importance of checking the specific technical publication. Structural repair of these members, apparently similar in construction, will thus vary in their load-carrying design with different aircraft.

Structural repair instructions, including tables of interchangeability and substitution for ferrous and nonferrous metals and their specifications for all types of aircraft used by the Navy, are normally prepared by the contractor. Such instructions are usually contained in the NA 02-XXX-3 manual covering structural repair instructions for specific models of aircraft. Similar information is also contained in *General Manual for Structural Repair*, NA 02-1A-1.

Aerospace Metals-General Data and Usage Factors, NA 02-1A-9, provides precise data on specific metals to assist in selection, usage, and processing for fabrication and repair. Always consult these publications and the NA 02-XXX-3 aircraft manual for the specific type of aircraft when confronted with a problem concerning maintenance and repair involving substitution and interchangeability of aircraft structural metals. Be sure you have the most recent issue of the aeronautic technical publication.

Q2-28. What metal property allows it to resist abrasion, penetration, cutting action, and permanent distortion?

Q2-29. What metal property enables a metal to return to its original shape after an applied force has been removed?

- Q2-30. At what temperature does aluminum alloy become a liquid form?
- Q2-31. What term is defined as the eating away or pitting of the surface or the internal structure of a metal?
- Q2-32. What property allows two metals to be welded, brazed, or soldered?
- Q2-33. What are the three basic metal working processes?
- Q2-34. What type of metal contains iron as its principal constituent?
- Q2-35. What are the two most commonly used methods of hardness testing?
- Q2-36. What are the two classes of wrought alloys?
- Q2-37. What type of metal is used in the construction of fire walls and fuselage skin adjacent to the engine exhaust outlet?

HARDNESS TESTING

LEARNING OBJECTIVES: Identify hardness testing methods. Identify related testing equipments and their operation.

Hardness testing is a method of determining the results of heat treatment as well as the state of a metal prior to heat treatment. Since hardness values can be tied in with tensile strength values and, in part, with wear resistance, hardness tests are an invaluable check of heat-treatment control and of material properties. Practically all hardness testing equipment now in service use the resistance to penetration as a measure of hardness.

TEST EQUIPMENT

Included among the better known bench-type hardness testers are the Brinell and the Rockwell. Also included are three portable type hardness testers—the Riehle, the Barcol, and the Ernst—which are all being used by maintenance activities.

Brinell Tester

The Brinell hardness tester, shown in figure 2-28, uses a hardened spherical ball, which is forced into the surface of the metal. The ball is 10 millimeters (0.3937 inch) in diameter. A pressure of 3,000 kilograms (6,600 pounds) is used for ferrous metals and 500 kilograms for nonferrous metals. Normally, the load should be

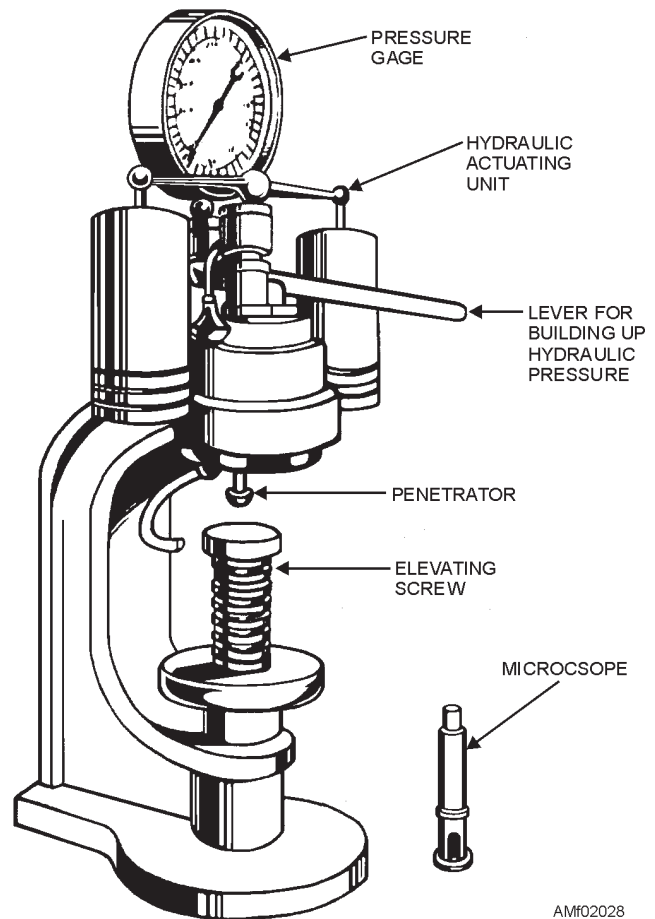
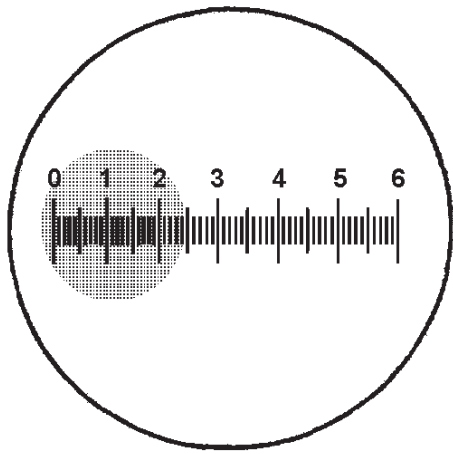

Figure 2-28.—Brinell hardness tester.

applied for 30 seconds. In order to produce equilibrium, this period may be increased to 1 minute for extremely hard steels. The load is applied by means of hydraulic pressure. The hydraulic pressure is built up by a hand pump or an electric motor, depending on the model of tester. A pressure gauge indicates the amount of pressure. There is a release mechanism for relieving the pressure after the test has been made, and a calibrated microscope is provided for measuring the diameter of the impression in millimeters. The machine has various shaped anvils for supporting the specimen and an elevating screw for bringing the specimen in contact with the ball penetrator. There are attachments for special tests.

To determine the Brinell hardness number for a metal, the diameter of the impression is first measured, using the calibrated microscope furnished with the



AMf02029

Figure 2-29.—Microscope view of impression.

tester. Figure 2-29 shows an impression as seen through the microscope. After measuring the diameter of the impression, the measurement is converted into the Brinell hardness number on the conversion table furnished with the tester. A portion of the conversion table is shown in table 2-3.

Table 2-3.—Portion of Conversion Table Furnished with Brinell Tester

Diameter of ball impression (mm)	Hardness number for load of kg	
	500	3000
2.0	158	945
2.05	150	899
2.10	143	856
2.15	136	817
2.20	130	780
2.25	124	745
2.30	119	712
2.35	114	682
2.40	109	653
2.45	100	627

Rockwell Tester

The Rockwell hardness tester, shown in figure 2-30, measures the resistance to penetration as does the Brinell tester, but instead of measuring the diameter of the impression, the Rockwell tester measures the depth, and the hardness is indicated directly on a dial attached

to the machine. The more shallow the penetration, the higher the hardness number.

Two types of penetrators are used with the Rockwell tester—a diamond cone and a hardened steel ball. The load that forces the penetrator into the metal is called the “major load,” and is measured in kilograms. The results of each penetrator and load combination are reported on separate scales, designated by letters. The penetrator, the major load, and the scale vary with the kind of metal being tested.

For hardened steels, the diamond penetrator is used, the major load is 150 kilograms, and the hardness is read on the C scale. When this reading is recorded, the letter C must precede the number indicated by the pointer. The C-scale setup is used for testing metals ranging in hardness from C-20 to the hardest steel (usually about C-70). If the metal is softer than C-20, the B-scale setup is used. With this setup, the 1/16-inch ball is used as a penetrator, the major load is 100 kilograms, and the hardness is read on the B scale.

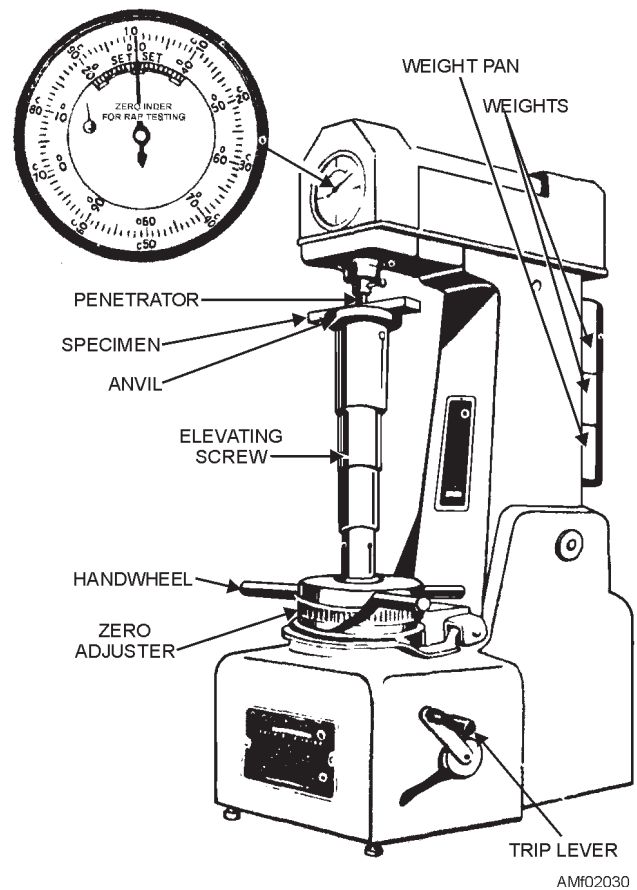

AMf02030

Figure 2-30.—Rockwell hardness tester.

In addition to the C and B scales, there are other setups for special testing. The scales, penetrators, major loads, and dial numbers are listed in table 2-4. The dial numbers in the outer circle are black, and the inner numbers are red.

The Rockwell tester is equipped with a weight pan, and two weights are supplied with the machine. One weight is marked in red. The other weight is marked in black. With no weight in the weight pan, the machine applies a major load of 60 kilograms. If the scale setup calls for a 100-kilogram load, the red weight is placed in the pan. For a 150-kilogram load, the black weight is added to the red weight. The black weight is always used in conjunction with the red weight; it is never used alone.

Practically all testing is done with either the B-scale setup or the C-scale setup. For these scales, the colors may be used as a guide in selecting the weight (or weights) and in reading the dial. For the B-scale test, use the red weight and read the red numbers. For a C-scale test, add the black weight to the red weight and read the black numbers.

In setting up the Rockwell machine, use the diamond penetrator for testing materials that are known to be hard. If in doubt, try the diamond, since the steel ball may be deformed if used for testing hard materials. If the metal tests below C-22, then change to the steel ball.

Use the steel ball for all soft materials—those testing less than B-100. Should an overlap occur at the top of the B scale and the bottom of the C scale, use the C-scale setup.

Before the major load is applied, the test specimen must be securely locked in place to prevent slipping and to properly seat the anvil and penetrator. To do this, a

load of 10 kilograms is applied before the lever is tripped. This preliminary load is called the “minor load.” The minor load is 10 kilograms regardless of the scale setup. When the machine is set up properly, it automatically applies the 10-kilogram load.

The metal to be tested in the Rockwell tester must be ground smooth on two opposite sides and be free of scratches and foreign matter. The surface should be perpendicular to the axis of penetration, and the two opposite ground surfaces should be parallel. If the specimen is tapered, the amount of error will depend on the taper. A curved surface will also cause a slight error in the hardness test. The amount of error depends on the curvature—the smaller the radius of curvature, the greater the error. To eliminate such error, a small flat should be ground on the curved surface if possible.

Riehle Tester

The Riehle hardness tester is a portable unit that is designed for making Rockwell tests comparable to the bench-type machine. The instrument is quite universal in its application, being readily adjustable to a wide range of sizes and shapes that would be difficult, or impossible, to test on a bench-type tester.

Figure 2-31 shows the tester and its proper use. It may be noted that the adjusting screws and the penetration indicator are set back some distance from the penetrator end of the clamps. This makes it practicable to use the tester on either the outside or inside surface of tubing, as well as on many other applications where the clearance above the penetrator or below the anvil is limited. The indicator brackets are arranged so that it is possible to turn the indicators to any angle for greater convenience in a specific application, or to facilitate its use by a left-handed operator. Adjustment of the lower clamp is made by the

Table 2-4.—Standard Rockwell Hardness Scales

Scale symbol	Penetrator	Major load (kg.)	Dial number
A	Diamond	60	Black
B	1/16-inch ball	100	Red
C	Diamond	150	Black
D	Diamond	100	Black
E	1/8-inch ball	100	Red
F	1/16-inch ball	60	Red
G	1/16-inch ball	150	Red
H	1/8-inch ball	60	Red
K	1/8-inch ball	150	Red

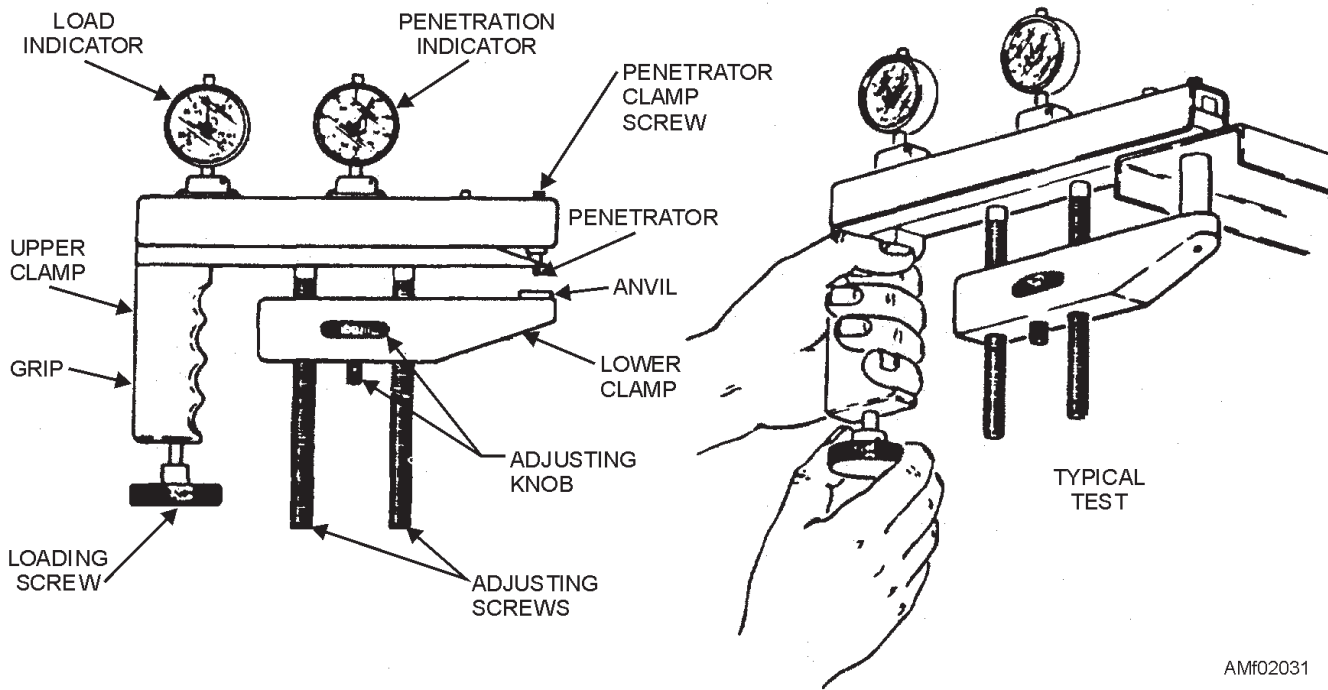

AMf02031

Figure 2-31.—Riehle portable hardness tester.

small knurled knob below the clamp. The larger diameter knob, extending through the slot in the side of the clamp, is used for actual clamping.

Each Riehle tester is supplied with a diamond penetrator and a 1/16-inch ball penetrator. The ball penetrator should not be used on materials harder than B-100 nor on a load heavier than 100 kilograms. This is to avoid the danger of flattening the ball.

The diamond penetrator, when used with a 150-kilogram load, may be used on materials from the hardest down to those giving a reading of C-20.

When the expected hardness of a material is completely unknown to the operator, it is advisable to take a preliminary reading on the A scale as a guide in selecting the proper scale to be used.

Testing Procedures

The basic procedures for making a test with the Riehle tester are as follows:

1. Apply a minor load of 10 kilograms.
2. Set the penetration indicator to zero.
3. Apply a major load of 60, 100, or 150 kilograms (depending on the scale), and then reduce the load back to the initial 10-kilogram load.
4. Read the hardness directly on the penetration indicator.

The hardness reading is based on the measurement of the additional increment of penetration produced by applying a major load after an initial penetration has been produced by the minor load. In reporting a hardness number, the number must be prefixed by the letter indicating the scale on which the reading was obtained.

Removal and Replacement of a Penetrator

The penetrator is retained in the tester by means of a small knurled clamp screw extending from the top of the upper clamp. To remove a penetrator, there should be at least 2 or 3 inches of space between the upper and lower clamps so that one hand can be placed underneath the upper clamp to catch the penetrator when it is released. Two or three turns of the clamp screw will release the penetrator. The two contact pins that extend through the penetrator on either side of the point are retained in the tester when the penetrator is removed.

To replace a penetrator, it must be turned so that the flat side faces the clamp screw, and the locating pin on the penetrator is in line with the slot provided to take the pin. The contact pins should be guided into their respective holes through the penetrator. With the penetrator in place, it should then be clamped securely by turning the clamp screw. Before you make an actual test, one or two preliminary tests should be made to properly seat the penetrator.

Barcol Tester

The Barcol hardness tester, shown in figure 2-32, is a portable unit designed for testing aluminum alloys, copper, brass, and other relatively soft materials. Approximate range of the tester is 25 to 100 Brinell. The unit can be used in any position and in any space that will allow for the operator's hand. The hardness is indicated on a dial conveniently divided in 100 graduations.

Figure 2-33 is a cutaway drawing of the tester, showing the internal parts and their general arrangement within the case.

The lower plunger guide and point are accurately ground so that attention need be given only to the proper position of the lower plunger guide within the frame to obtain accurate operation when a point is replaced.

The frame, into which the lower plunger guide and spring-tensioned plunger are screwed, holds the point in the proper position. Adjustment of the plunger upper guide nut, which regulates the spring tension, is made when the instrument is calibrated at the factory.

CAUTION

The position of this nut should not be changed. Any adjustment made to the plunger upper guide nut will void the calibrated settings made at the factory.

The leg is set for testing surfaces that permit the lower plunger guide and the leg plate to be on the same plane. For testing rivets or other raised objects, a block may be placed under the leg plate to raise it to the same

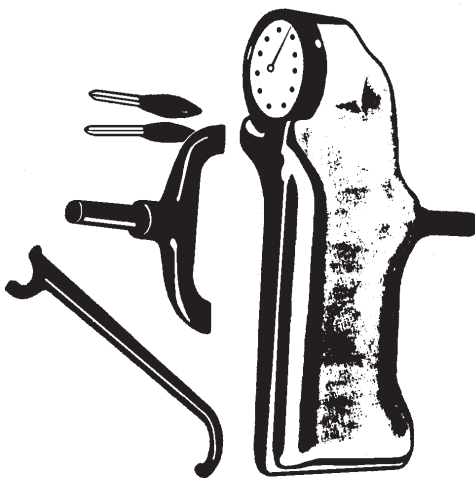

AMf02032

Figure 2-32.—Barcol portable hardness tester.

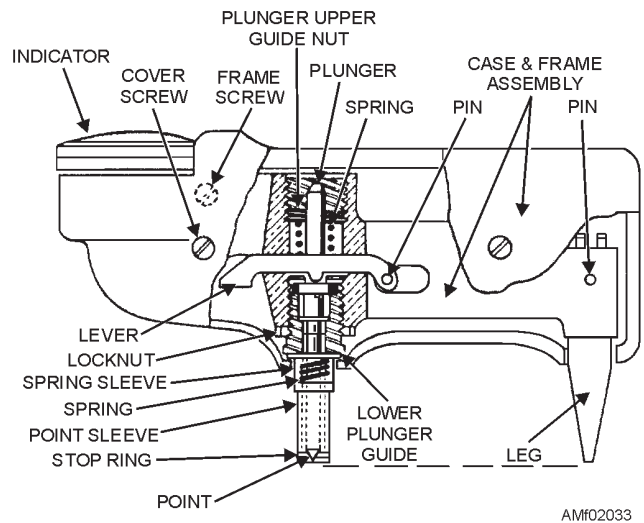

AMf02033

Figure 2-33.—Cutaway of Barcol tester.

plane. For permanent testing of this type, the leg may be removed and washers inserted, as shown in the drawing. The point should always be perpendicular to the surface being tested.

The design of the Barcol tester is such that operating experience is not necessary. It is only necessary to exert a light pressure against the instrument to drive the spring-loaded indenter into the material to be tested. The hardness reading is instantly indicated on the dial. Several typical readings for aluminum alloys are listed in table 2-5. The harder the material, the higher the Barcol number.

Table 2-5.—Typical Barcol Readings for Aluminum Alloys

Alloy and temper	Barcol number
1100-0	35
3003-0	42
3003-1/2H	56
2024-0	60
5052-0	62
5052-1/2H	75
6061-T	78
2024-T	85

To prevent damage to the point, avoid sliding or scraping when it is in contact with the material being tested. If the point should become damaged, it must be replaced with a new one. No attempt should be made to grind the point.

Each tester is supplied with a test disc for checking the condition of the point. To check the condition of the point, press the instrument down on the test disc. When the downward pressure brings the end of the lower plunger guide against the surface of the disc, the indicator reading should be within the range shown on the test disc.

To replace the point, remove the two screws that hold the halves of the case together. Lift out the frame, remove the spring sleeve, loosen the locknut, and unscrew the lower plunger guide, holding the point upward so that the spring and plunger will not fall out of place. Insert the new point and replace the lower plunger guide, screwing it back into the frame. Adjust the lower plunger guide with the wrench that is furnished until the indicator reading and the test disc average number are identical. After the lower plunger guide is properly set, tighten the locknut to keep the lower plunger guide in place. This adjustment should be made only after installing a new point; any readjustment on a worn or damaged point give erroneous readings.

Ernst Tester

The Ernst tester is a small versatile tool that requires access to only one side of the material being tested. There are two models of the tester—one for testing hardened steels and hard alloys and one for testing unhardened steels and most nonferrous metals. It has a diamond point penetrator, and it is read directly from the Rockwell A or B or the Brinell scales, depending on the model used. Figure 2-34 shows the Ernst portable hardness tester and its proper use.



THE ERNST PORTABLE HARDNESS TESTER HAS A DIAMOND-TIPPED PENETRATOR AND READS IN ROCKWELL OR BRINELL SCALES.

The correct procedures for using the Ernst tester are as follows:

1. Solidly support the metal being tested by placing a bucking bar behind the metal. This will minimize flexing of the metal and yield a more accurate reading of hardness.
2. The handgrip must be pressed down with a steady, even force to ensure accurate readings.
3. Press down until the fluid column has stopped moving. The hardness value is given at the point where the fluid column has stopped moving on the scale.

As with other portable testers of similar type, the material must be smooth and backed up so there will be no tendency to sag under the load applied on the tester. The test block supplied with each tester should be used frequently to check its performance.

- Q2-38. *What measurement must be taken to determine the Brinell number of a metal?*
- Q2-39. *How does a Rockwell tester measure the hardness of a metal?*
- Q2-40. *The Riehle tester is designed for making tests comparable to what bench type machine?*
- Q2-41. *What hardness tester is used for testing aluminum alloys, copper, brass, and other soft metals?*

NONMETALLIC MATERIALS

LEARNING OBJECTIVES: Identify the properties of nonmetallic materials used in aircraft construction. Identify the properties of composite materials used in aircraft construction.

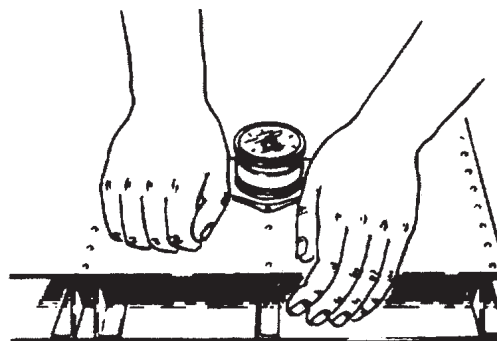

NOTE:
MATERIAL MUST BE SOLIDLY SUPPORTED FROM BEHIND. PRESS DOWN WITH A STEADY, EVEN FORCE.

AMf02034

Figure 2-34.—Ernst portable hardness tester.

Transparent plastics, reinforced plastics, and composite materials are common materials used in aircraft construction. Sandwich construction is used for radomes as well as for structural areas where strength and rigidity are important. Laminate construction is also used in aircraft construction.

TRANSPARENT PLASTICS

Transparent plastic materials used in aircraft canopies, windshields, and other transparent enclosures may be divided into two major classes, or groups, depending on their reaction to heat. They are the thermoplastic materials and the thermosetting materials.

Thermoplastic materials will soften when heated and harden when cooled. These materials can be heated until soft, formed into the desired shape, and when cooled, will retain this shape. The same piece of plastic can be reheated and reshaped any number of times without changing the chemical composition of the material.

Thermosetting plastics harden upon heating, and reheating has no softening effect. They cannot be reshaped after once being fully cured by the application of heat. These materials are rapidly being phased out in favor of stretched acrylic, a thermoplastic material.

Transparent plastics are manufactured in two forms of material—solid (monolithic) and laminated. Laminated plastic consists of two sheets of solid plastic bonded to a rubbery inner layer of material similar to the sandwich materials used in plate glass.

Laminated transparent plastics are well suited to pressurized applications in aircraft because of their shatter resistance, which is much higher than that of the stretched solid plastics.

Stretched acrylic is a thermoplastic conforming to Military Specification MIL-P-25690. This specification covers transparent, solid, modified acrylic sheet material having superior crack propagation resistance (shatter resistance, craze resistance, fatigue resistance) as a result of proper hot stretching.

Stretched acrylic is prepared from modified acrylic sheets, using a processing technique in which the sheet is heated to its forming temperature and then mechanically stretched so as to increase its area approximately three or four times with a resultant decrease in its thickness. Most of the Navy's high-speed aircraft are equipped with canopies made from stretched acrylic plastic.

Identification

Most transparent plastic sheet used in naval aircraft is manufactured in accordance with various military specifications, some of which are listed in table 2-6. Individual sheets are covered with a heavy masking paper on which the specification number appears. In addition to serving as a means of identification, the masking paper helps to prevent accidental scratching of the plastic during storage and handling.

Identification of unmasked sheets of plastic is often difficult; however, the following information may serve as an aid. MIL-P-8184, a modified acrylic plastic, has a

Table 2-6.—Transparent Plastics

Type	Specification No.
Solid Thermoplastic	
Thermoplastic	
Heat-resistant acrylic	MIL-P-5425
Modified acrylic	MIL-P-8184
Stretched modified acrylic (8184)	MIL-P-25690
Thermosetting	
Polyester craze resistant	MIL-P-8257
Laminated	
Laminated modified acrylic (8184)	MIL-P-25374

slight yellowish tint when viewed from the edge; MIL-P-8257, a thermosetting polyester plastic, has a bluish or blue-green tint; and MIL-P-5425, a heat-resistant acrylic, is practically clear. In addition, stretched acrylic sheets and fabricated assemblies are permanently marked to ensure positive identification.

Plastic enclosures on aircraft may be distinguished from plate glass enclosures by tapping lightly with a blunt instrument. Plastic will resound with a dull thud or soft sound, whereas plate glass will resound with a metallic sound or ring.

Storage and Handling

Transparent plastic sheets are available in a number of thicknesses and sizes that can be cut and formed to required sizes and shapes. These plastics will soften and/or deform when heated sufficiently; therefore, storage areas having high temperatures must be avoided. Plastic sheets should be kept away from heating coils, radiators, hot water, and steam lines. Storage should be in a cool, dry location away from solvent fumes, such as may exist near paint spray and paint storage areas. Paper masked transparent plastic sheets should be kept indoors as direct rays of the sun will accelerate deterioration of the masking paper adhesive, causing it to cling to the plastic so that removal is difficult.

Plastic sheets should be stored, with the masking paper in place, in bins that are tilted at approximately 10 degrees from the vertical to prevent buckling. If it is necessary to store sheets horizontally, you should take care to avoid chips and dirt getting between the sheets. Stacks should not be over 18 inches high, and small sheets should be stacked on the larger ones to avoid unsupported overhead. Storage of transparent plastic sheets presents no special fire hazard, as they are slow burning.

Masking paper should be left on the plastic sheet as long as possible. You should take care to avoid scratches and gouges, which may be caused by sliding sheets against one another or across rough or dirty tables.

Formed sections should be stored so that they are amply supported and there is no tendency for them to lose their shape. Vertical nesting should be avoided. Protect formed parts from temperatures higher than 120°F. Protection from scratches may be provided by applying a protective coating of masking paper or other approved materials.

If masking paper adhesive deteriorates through long or improper storage, making removal of paper difficult, moisten the paper with aliphatic naphtha,

which will loosen the adhesive. Sheets so treated should be washed immediately with clear water.

CAUTION

Aliphatic naphtha is highly volatile and flammable. You should exercise extreme care when using this solvent.

Do not use gasoline, alcohol, kerosene, xylene, ketones, lacquer thinners, aromatic hydrocarbons, ethers, glass cleaning compounds, or other unapproved solvents on transparent acrylic plastics to remove masking paper or other foreign material, as these will soften and/or craze the plastic surface.

NOTE: Just as woods split and metals crack in areas of high, localized stress, plastic materials develop, under similar conditions, small surface fissures called "crazing." These tiny cracks are approximately perpendicular to the surface, very narrow in width, and usually not over 0.01 inch in depth. These tiny fissures are not only an optical defect, but also a mechanical defect, inasmuch as there is a separation or parting of the material. Once a part has been crazed, neither the optical nor mechanical defect can be removed permanently; therefore, prevention of crazing is a necessity.

When it is necessary to remove masking paper from the plastic sheet during fabrication, the surface should be remarketed as soon as possible. Either replace the original paper on relatively flat parts or apply a protective coating on curved parts.

Machining

Machining qualities of transparent plastics are similar to those of brass or soft copper. Cutting edges of tools should have no rack and perform a scraping action, rather than a cutting action. Tools and work should be held firmly to prevent vibration and chattering. The feed of the work should be constant: if the work stops, it will be burned. The use of large amounts of water-based coolant will also prevent burning.

REINFORCED PLASTICS

Glass fiber reinforced plastic and honeycomb are used in the construction of radomes, wing tips, stabilizer tips, antenna covers, fairings, access covers, etc. It has excellent dielectric characteristics, making it

ideal for use in radomes. Its high strength/weight ratio, resistance to mildew and rot, and ease of fabrication make it equally suited for other parts of the aircraft.

The manufacture of reinforced plastic laminates involves the use of liquid resins reinforced with a filler material. The resin, when properly treated with certain agents known as catalysts, or hardeners, changes to an infusible solid.

The reinforcement materials are impregnated with the resin while the latter is still in the liquid (uncured) state. Layers or plies of cloth are stacked up and heated under pressure in a mold to produce the finished, cured shape. Another technique, called "filament winding," consists of winding a continuous glass filament or tape, impregnated with uncured resin, over a rotating male form. Cure is accomplished in a manner similar to the woven cloth reinforced laminates. Glass fiber reinforced honeycomb consists of a relatively thick, central layer called the "core" and two outer laminates called "facings." (See figure 2-25.)

The core material commonly used in radome construction consists of a honeycomb structure made of glass cloth impregnated either with a polyester or epoxy or a combination of nylon and phenolic resin. The material is normally fabricated in blocks that are later cut on a band saw to slices of the exact thickness desired, or it may be originally fabricated to the proper thickness.

The facings are made up of several layers of glass cloth, impregnated and bonded together with resin. Each layer of cloth is placed in position and impregnated with resin before another layer is added. Thicker cloths are normally used for the body of the facings, with one or more layers of finer weave cloth on the surface.

The resins are thick, syrupy liquids of the so-called contact-pressure type (requiring little or no pressure during cure), sometimes referred to as contact resins. They are usually thermosetting polyester or epoxy resins. Cure can be affected by adding a catalyst and heating, or they can be cured at different temperatures by adjusting the amount and type of catalysts.

Types of Composite Material

Composites are materials consisting of a combination of high-strength stiff fibers embedded in a common matrix (binder) material; for example, graphite fibers and epoxy resin. Composite structures are made of a number of fiber and epoxy resin

laminates. These laminates can number from 2 to greater than 50, and are generally bonded to a substructure such as aluminum or nonmetallic honeycomb. The much stiffer fibers of graphite, boron, and Kevlar[®] epoxies have given composite materials structural properties superior to the metal alloys they have replaced.

The use of composites is not new. Fiber glass, for example, has been used for some time in various aircraft components. However, the term *advanced composites* applies to graphite, boron, and Kevlar[®], which have fibers of superior strength and stiffness. The use of these advanced composite materials does represent a new application for naval aircraft.

Composite materials are replacing and supplementing metallic materials in various aircraft structural components. The first materials were used with laminated fiber glass radomes and helicopter rotor blades. In recent years, the replacement of metallic materials with more advanced composite materials has rapidly accelerated. This has become particularly evident with the advent of the F/A-18, AV-8B, SH-60B, and CH-53E aircraft; and it is anticipated that composite materials will continue to comprise much of the structure in future aircraft. As a result, there is a growing requirement to train you in the use of advanced composite materials.

There are numerous combinations of composite materials being studied in laboratories and a number of types currently used in the production of aircraft components. Examples of composite materials are as follows: graphite/epoxy, Kevlar[®]/epoxy, boron polyamide, graphite polyamide, boron-coated boron aluminum, coated boron titanium, boron graphite epoxy hybrid, and boron/epoxy. The trend is toward minimum use of boron/epoxy because of the cost when compared to current generation of graphite/epoxy composites.

Composites are attractive structural materials because they provide a high strength/weight ratio and offer design flexibility. In contrast to traditional materials of construction, the properties of these materials can be adjusted to more efficiently match the requirements of specific applications. However, these materials are highly susceptible to impact damage, and the extent of the damage is difficult to determine visually. Nondestructive inspection (NDI) is required to analyze the extent of damage and the effectiveness of repairs. In addition, repair differs from traditional metallic repair techniques.

GRAPHITE.—Carbon graphite fibers were first developed by Thomas Edison while experimenting with the incandescent light bulb. It is made from synthetic material and carbonized in an inert environment at temperatures around 3000°F. Carbon fibers are readily woven into various patterns. They are used to manufacture complex contoured parts. The majority of advanced composite parts on naval aircraft are made of carbon fibers.

KEVLAR®.—DuPont's Aramid Kevlar® material is a synthetic polymer. Although these fibers may be readily woven into fabrics, they have poor compression properties that limit their use to internal ducts, nonstructural access covers, fairings, and lightly loaded helicopter skins.

BORON.—Boron fibers are made by chemical vapor deposition (deposits) of boron onto a tungsten wire 0.0005" in diameter. Boron fibers have a high bending stiffness, and cannot be easily woven into cloth or used for complex contoured parts.

Construction

Laminate construction consists of skin and substructures that are manufactured by laminating plies of prepreg material (prepreg). Sandwich construction parts used on naval aircraft can be divided into two broad classes: (1) radomes and (2) structural.

LAMINATE CONSTRUCTION.—Prepreg is the basic building block of advanced composites. It consists of fibers preimpregnated with partially cured matrix material. These plies of prepreg are cut to the proper size and shape and stacked in specific fiber orientation. This stack up is then fully cured using heat and pressure. Excess resin bled during the cure bonds the plies together to form a solid laminate.

SANDWICH CONSTRUCTION.—The first class, radomes, is a reinforced plastic sandwich construction designed primarily to permit accurate and dependable functioning of the radar equipment.

The second class, referred to as structural sandwich, normally has either metal or reinforced plastic facings on cores of aluminum or balsa wood. This material is found in a variety of places, such as wing surfaces, decks, bulkheads, stabilizer surfaces, ailerons, trim tabs, access doors, and bomb bay doors.

Figure 2-35 shows one type of sandwich construction that uses a honeycomb-like aluminum

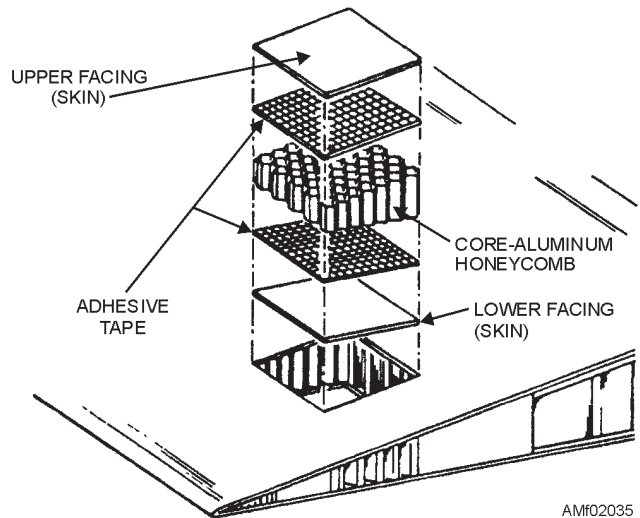

Figure 2-35.—Sandwich construction.

alloy core, sandwiched between aluminum alloy sheets, called “facings.” The facings are bonded to the lightweight aluminum core with a suitable adhesive so as to develop a strength far greater than that of the components themselves when used alone.

Another type of structural sandwich construction consists of a low-density balsa wood core combined with high-strength aluminum alloy facings bonded to each side of the core. The grain in the balsa core runs perpendicular to the aluminum alloy facings, and the core and aluminum facings are firmly bonded together under controlled temperatures and pressures.

The facings in this type of construction carry the major bending loads, and the cores serve to support the facings and carry the shear loads. The outstanding characteristics of sandwich construction are strength, rigidity, lightness, and surface smoothness.

- Q2-42. *What type of plastic will soften when heated and harden when cooled?*
- Q2-43. *What type of plastic will harden when it is heated?*
- Q2-44. *Plastic sheets should be stored in a bin and must be tilted at least how many degrees from vertical?*
- Q2-45. *What are the three types of advanced composites used on naval aircraft?*

CHAPTER 3

AIRCRAFT HARDWARE

INTRODUCTION

Because of the small size of most hardware items, their importance is often overlooked. The safe and efficient operation of any aircraft is greatly dependent upon correct selection and use of aircraft structural hardware and seals. Aircraft hardware is discussed in detail in the *Structural Hardware Manual*, NAVAIR 01-1A-8.

Aircraft hardware is usually identified by its specification number or trade name. Threaded fasteners and rivets are usually identified by AN (Air Force-Navy), NAS (national aircraft standard), and MS (military standard) numbers. Quick-release fasteners are usually identified by factory trade names and size designations.

To obtain aircraft hardware from supply, the specification numbers and the factory part numbers are changed into stock numbers (NSN). This is done by using a part number cross-reference index.

AIRCRAFT STRUCTURAL HARDWARE

LEARNING OBJECTIVES: Identify the various types of rivets used in the construction and repair of naval aircraft. Identify the various types of fasteners used in the construction and repair of naval aircraft. Identify the cable and cable guides used in aircraft construction and repair.

The term *aircraft structural hardware* refers to many items used in aircraft construction. These items include such hardware as rivets, fasteners, bolts, nuts, screws, washers, cables, guides, and common electrical system hardware.

RIVETS

The fact that there are thousands of rivets in an airframe is an indication of how important riveting is in the AM rating. A glance at any aircraft will show the thousands of rivets in the outer skin alone. Besides the riveted skin, rivets are also used for joining spar sections, for holding rib sections in place, for securing fittings to various parts of the aircraft, and for fastening bracing members and other parts together. Rivets that are satisfactory for one part of the aircraft are often unsatisfactory for another part. Therefore, it is important that you know the strength and driving properties of the various types of rivets and how to identify them, as well as how to drive or install them.

Solid Rivets

Solid rivets are classified by their head shape, by the material from which they are manufactured, and by their size. Rivet head shapes and their identifying code numbers are shown in figure 3-1. The prefix MS identifies hardware that conforms to written military standards. The prefix AN identifies specifications that are developed and issued under the joint authority of the Air Force and the Navy.

Rivet Identification Code

The rivet codes shown in figure 3-1 are sufficient to identify rivets only by head shape. To be meaningful and precisely identify a rivet, certain other information is encoded and added to the basic code.

A letter or letters following the head-shaped code identify the material or alloy from which the rivet was

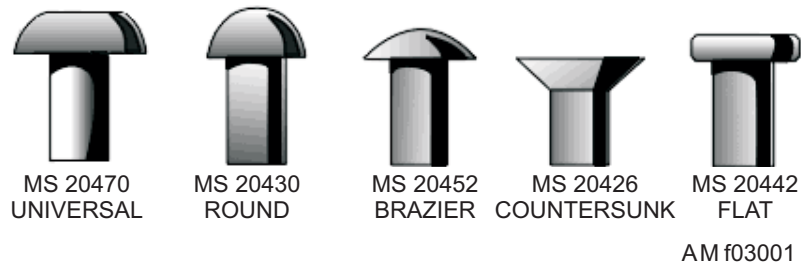

Figure 3-1.—Rivet head shapes and code numbers.

Table 3-1.—Rivet Material Identification

MATERIAL OR ALLOY	CODE LETTERS	HEAD MARKING ON RIVET
1100-F	A	Plain
2117-T4	AD	Indented dimple
2017-T4	D	Raised teat
2024-T4	DD	Raised double dash
5056-H32	B	Raised cross

made. Table 3-1 includes a listing of the most common of these codes. The alloy code is followed by two numbers separated by a dash. The first number is the numerator of a fraction, which specifies the shank diameter in thirty-seconds of an inch. The second number is the numerator of a fraction in sixteenths of an inch, and identifies the length of the rivet. The rivet code is shown in figure 3-2.

Rivet Composition

Most of the rivets used in aircraft construction are made of aluminum alloy. A few special-purpose rivets are made of mild steel, Monel, titanium, and copper. Those aluminum alloy rivets made of 1100, 2117, 2017, 2024, and 5056 are considered standard.

ALLOY 1100 RIVETS.—Alloy 1100 rivets are supplied as fabricated (F) temper, and are driven in this condition. No further treatment of the rivet is required before use, and the rivet's properties do not change with prolonged periods of storage. They are relatively soft and easy to drive. The cold work resulting from driving increases their strength slightly. The 1100-F rivets are used only for riveting nonstructural parts. These rivets are identified by their plain head, as shown in table 3-1.

ALLOY 2117 RIVETS.—Like the 1100-F rivets, these rivets need no further treatment before use and can be stored indefinitely. They are furnished in the solution-heat-treated (T4) temper, but change to the

solution-heat-treated and cold-worked (T3) temper after driving. The 2117-T4 rivet is in general use throughout aircraft structures, and is by far the most widely used rivet, especially in repair work. In most cases the 2117-T4 rivet may be substituted for 2017-T4 and 2024-T4 rivets for repair work by using a rivet with the next larger diameter. This is desirable since both the 2017-T4 and 2024-T4 rivets must be heat treated before they are used or kept in cold storage. The 2117-T4 rivets are identified by a dimple in the head.

ALLOY 2017 AND 2024 RIVETS.—Both these rivets are supplied in the T4 temper and must be heat-treated. These rivets must be driven within 20 minutes after quenching or refrigerated at or below 32°F to delay the aging time 24 hours. If either time is exceeded, reheat treatment is required. These rivets may be reheated as many times as desired, provided the proper solution heat-treatment temperature is not exceeded. The 2024-T4 rivets are stronger than the 2017-T4 and are, therefore, harder to drive. The 2017-T4 rivet is identified by the raised teat on the head, while the 2024-T4 has two raised dashes on the head.

ALLOY 5056 RIVETS.—These rivets are used primarily for joining magnesium alloy structures because of their corrosion-resistant qualities. They are supplied in the H32 temper (strain-hardened and then stabilized). These rivets are identified by a raised cross on the head. The 5056-H32 rivet may be stored

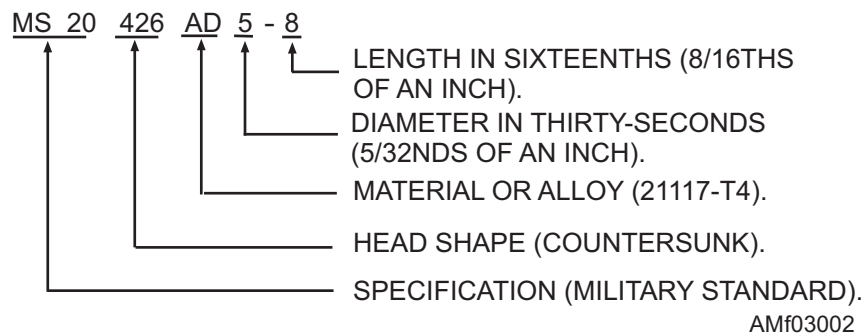

Figure 3-2.—Rivet coding example.

indefinitely with no change in its driving characteristics.

Blind Rivets

In places accessible from only one side or where space on one side is too restricted to properly use a bucking bar, blind rivets are usually used. Blind rivets may also be used to secure nonstructural parts to the airframe.

Self-Plugging Mechanical Lock

Figure 3-3 shows a blind rivet that uses a mechanical lock between the head of the rivet and the pull stem. Note in view B that the collar that is attached to the head has been driven into the head and has assumed a wedge or cone shape around the groove in the pin. This holds the shank firmly in place from the head side.

The self-plugging rivet is made of 5056-H14 aluminum alloy and includes the conical recess and locking collar in the rivet head. The stem is made of 2024-T36 aluminum alloy. Pull grooves that fit into the jaws of the rivet gun are provided on the stem end that protrudes above the rivet head. The blind end portion of the stem incorporates a head and a land (the raised portion of the grooved surface) with an extruding angle that expands the rivet shank.

Applied loads for self-plugging rivets are comparable to those for solid shank rivets of the same shear strength, regardless of sheet thickness. The composite shear strength of the 5056-H14 shank and the 2024-T36 pin exceeds 38,000 psi. Their tensile strength is in excess of 28,000 psi. Pin retention characteristics are excellent in these rivets. The

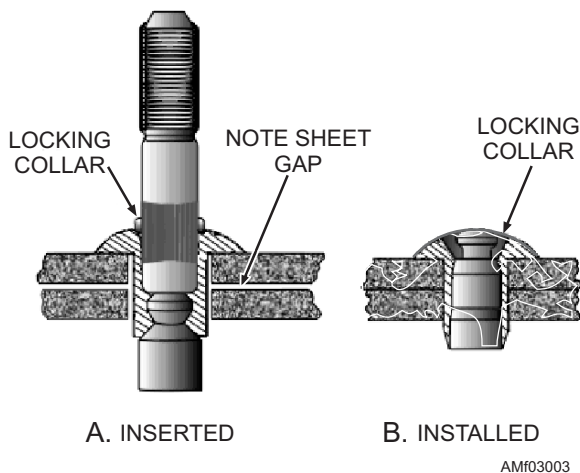

Figure 3-3.—Self-plugging rivet (mechanical lock).

possibility of the pin working out is minimized by the lock formed in the rivet head.

Self-Plugging Friction Lock

Self-plugging friction lock rivets are available in universal and flush head styles and are manufactured from 2117 and 5056 aluminum alloy and Monel. Self-plugging friction lock rivets cannot be substituted for solid rivets, nor can they be used in critical applications, such as control surface hinge brackets, wing attachment fittings, landing gear fittings, and fluid-tight joints. Figure 3-4 shows a self-plugging friction lock rivet and the proper installation procedure.

Hi-Shear Rivets

Hi-shear (pin) rivets are essentially threadless bolts. The pin is headed at one end and is grooved about the circumference at the other. A metal collar is swaged onto the grooved end. They are available in two head styles—the flat protruding head and the flush protruding head. Hi-shear rivets are made in a variety of materials, and are used only in shear applications. Because the shear strength of the rivet is greater than either the shear or bearing strength of sheet aluminum alloys, they are used primarily to rivet thick gauge sheets together. They are never used where the

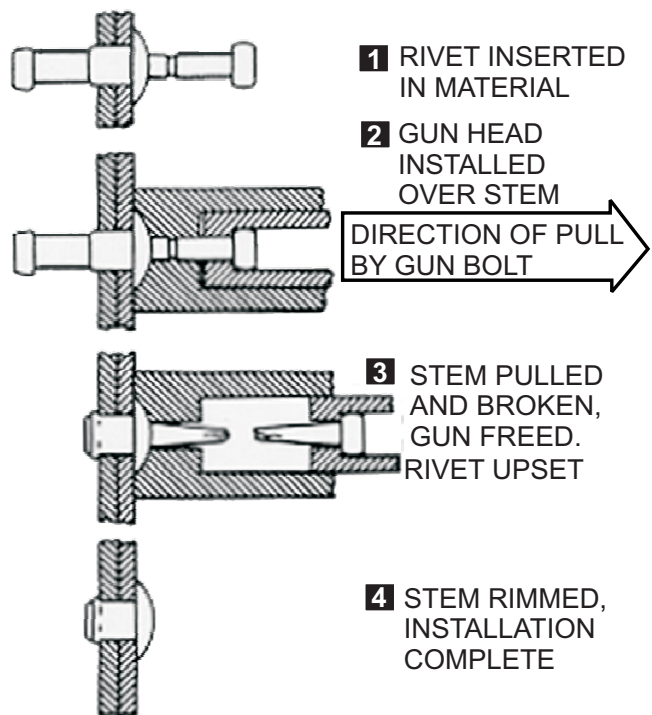

Figure 3-4.—Self-plugging rivet (friction lock).

grip length is less than the shank diameter. Hi-shear rivets are shown in figure 3-5.

Hi-shear rivets are identified by code numbers similar to the solid rivets. The size of the rivet is measured in increments of thirty-seconds of an inch for the diameter and sixteenths of an inch for the grip length. For example, an NAS1055-5-7 rivet would be a hi-shear rivet with a countersunk head. Its diameter would be 5/32 of an inch and its maximum grip length would be 7/16 of an inch.

The collars are identified by a basic code number and a dash number that correspond to the diameter of the rivet. An A before the dash number indicates an aluminum alloy collar. The NAS528-A5 collar would be used on a 5/32-inch-diameter rivet pin. Repair procedures involving the installation or replacement of hi-shear rivets generally specify the collar to be used.

Rivnuts

The rivnut is a hollow rivet made of 6063 aluminum alloy, counterbored and threaded on the inside. They are manufactured in two head styles, flat and countersunk, and in two shank designs, open and closed ends. See figure 3-6. Each of these rivets is available in three sizes: 6-32, 8-32, and 10-32. These numbers indicate the nominal diameter and the actual number of threads per inch of the machine screw that fits into the rivnut.

Open-end rivnuts are the most widely used, and are recommended in preference to the closed-end type. However, in sealed flotation or pressurized compartments, the closed-end rivnut must be used.

- Q3-1. Solid rivets are classified according to what three factors?
- Q3-2. A rivet with the code number MS 20426 has what type of rivet head?
- Q3-3. What code identifies a rivet with a plain head marking?
- Q3-4. Rivets used primarily for joining magnesium alloy structures have what alloy designation?

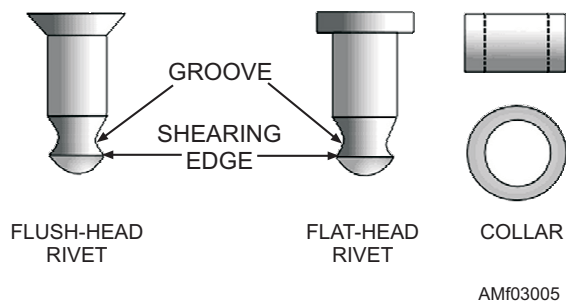

Figure 3-5.—Hi-shear rivet.

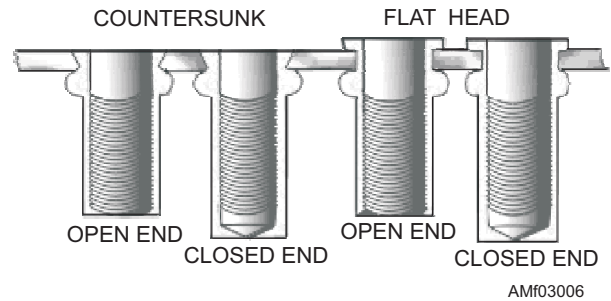

Figure 3-6.—Sectional view of rivnut showing head and end designs.

- Q3-5. When space is too restricted to properly use a bucking bar, what type of rivet should be used?
- Q3-6. Hi-shear (pin) rivets are available in what two head styles?

FASTENERS (SPECIAL)

Fasteners on aircraft are designed for many different functions. Some are made for high-strength requirements, while others are designed for easy installation and removal.

Lock-Bolt Fasteners

Lock-bolt fasteners are designed to meet high-strength requirements. Used in many structural applications, their shear and tensile strengths equal or exceed the requirements of AN and NAS bolts.

The lock-bolt pin, shown in view A of figure 3-7, consists of a pin and collar. It is available in two head

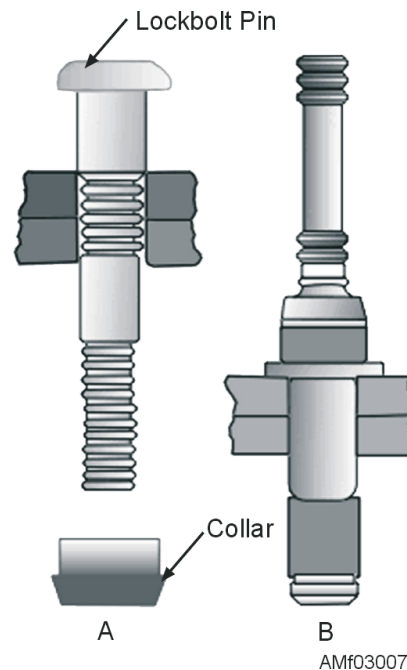

Figure 3-7.—Lock bolts.

styles: protruding and countersunk. Pin retention is accomplished by swaging the collar into the locking grooves on the pin.

The blind lock bolt, shown in view B of figure 3-6, is similar to the self-plugging rivet shown in figure 3-3. It features a positive mechanical lock for pin retention.

Hi-Lok Fasteners

The hi-lok fastener, shown in figure 3-8, combines the features of a rivet and a bolt and is used for high-strength, interference-free fit of primary structures. The hi-lok fastener consists of a threaded pin and threaded locking collar. The pins are made of cadmium-plated alloy steel with protruding or 100-degree flush heads. Collars for the pins are made of anodized 2024-T6 aluminum or stainless steel. The threaded end of the pin is recessed with a hexagon socket to allow installation from one side. The major diameter of the threaded part of the pin has been truncated (cut undersize) to accommodate a 0.004-inch maximum interference-free fit. One end of the collar is internally recessed with a 1/16-inch, built-in variation that automatically provides for variable material thickness without the use of washers and without fastener preload changes. The other end of the collar has a torque-off wrenching device that controls a predetermined residual tension of preload (10%) in the fastener.

Jo-Bolt Fasteners

The Jo-bolt, shown in figure 3-9, is a high-strength, blind structural fastener that is used on difficult riveting jobs when access to one side of the work is impossible. The Jo-bolt consists of three factory-assembled parts: an aluminum alloy or alloy steel nut, a threaded alloy steel bolt, and a corrosion-resistant steel sleeve. The

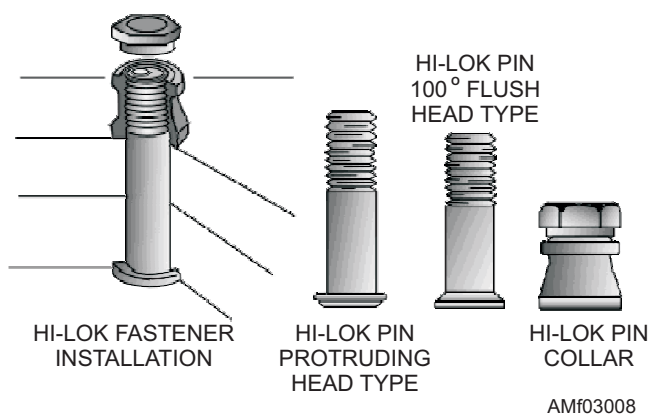

Figure 3-8.—Hi-lok fastener.

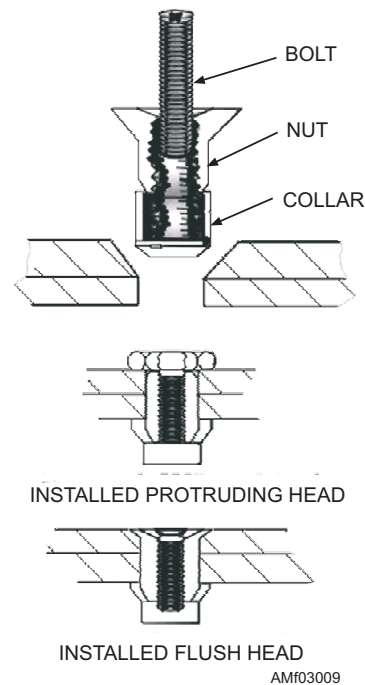

Figure 3-9.—Jo-bolt.

head styles available for Jo-bolts are the 100-degree flush head, the hexagon protruding head, and the 100-degree flush millable head.

FASTENERS (THREADED)

Although thousands of rivets are used in aircraft construction, many parts require frequent dismantling or replacement. For these parts it is more practical to use some form of threaded fastener. Furthermore, some joints require greater strength and rigidity than can be provided by riveting. Manufacturers solve this problem by using various types of screws, bolts, nuts, washers, and fasteners.

Bolts and screws are similar in that both have a head at one end and a screw thread at the other, but there are several differences between them. The threaded end of a bolt is always relatively blunt, while that of a screw may be either blunt or pointed. The threaded end of a bolt must be screwed into a nut, but the threaded end of the screw may fit into a nut or other female arrangement, or directly into the material being secured. A bolt has a fairly short threaded section and a comparatively long grip length (the unthreaded part); a screw may have a longer threaded section and no clearly defined grip length. A bolt assembly is generally tightened by turning its nuts. Its head may or may not be designed to be turned. A screw is always designed to be turned by its head. Another minor but

frequent difference between a screw and a bolt is that a screw is usually made of lower strength materials.

Threads on aircraft bolts and screws are of the American National Standard type. This standard contains two series of threads: national coarse (NC) and national fine (NF) series. Most aircraft threads are of the NF series.

Threads are also produced in right-hand and left-hand types. A right-hand thread advances into engagement when turned clockwise. A left-hand thread advances into engagement when turned counter-clockwise.

Threads are sized by both the diameter and the number of threads per inch. The diameter is designated by screw gauge number for sizes up to 1/4 inch, and by nominal size for those 1/4 inch and larger. Screw gauge numbers range from 0 to 12, except that numbers 7, 9, and 11 are omitted. Threads are designated by the diameter, number of threads per inch, thread series, and class in parts catalogs, on blueprints, and on repair diagrams.

For example, No. 8-32NF-3 indicates a No. 8 size thread, 32 threads per inch, national fine series, and a class 3 thread. Also, 1/4-20NC-3 indicates a 1/4-inch thread, 20 threads per inch, national coarse series, and a class 3 thread. A left-hand thread is indicated by the letters *LH* following the class of thread.

Bolts

Many types of bolts are used on aircraft. However, before discussing some of these types, it might be helpful to list and explain some commonly used bolt terms. You should know the names of bolt parts and be aware of the bolt dimensions that must be considered in selecting a bolt. Figure 3-10 shows both types of information.

The three principal parts of a bolt are the head, thread, and grip. The head is the larger diameter of the

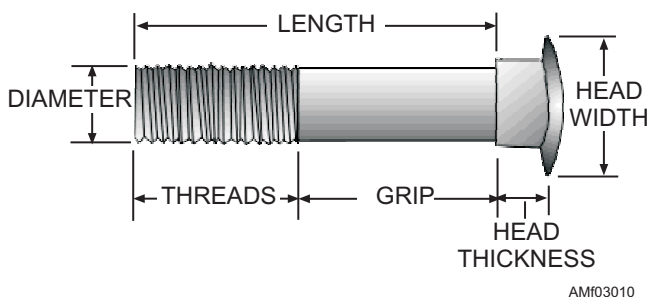
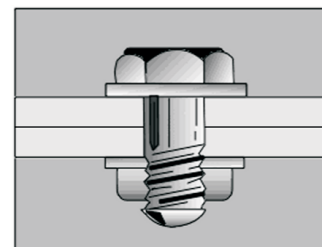

Figure 3-10.—Bolt terms and dimensions.

bolt and may be one of many shapes or designs. The head keeps the bolt in place in one direction, and the nut used on the threads keeps it in place in the other direction.

To choose the correct replacement, several bolt dimensions must be considered. One is the length of the bolt. Note in figure 3-10 that the bolt length is the distance from the tip of the threaded end to the head of the bolt. Correct length selection is indicated when the chosen bolt extends through the nut at least two full threads. In the case of flat-end bolts or chamfered (rounded) end bolts, at least the full chamfer plus one full thread should extend through the nut. See figure 3-10. If the bolt is too short, it may not extend out of the bolt hole far enough for the nut to be securely fastened. If it is too long, it may extend so far that it interferes with the movement of nearby parts. Unnecessarily long bolts can affect weight and balance and reduce the aircraft payload capacity.

In addition, if a bolt is too long or too short, its grip is usually the wrong length. As shown in figure 3-11, grip length should be approximately the same as the thickness of the material to be fastened. If the grip is too



Bolt Grip Length Correct

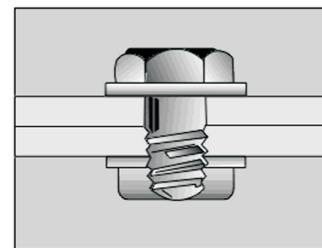

Bolt Length Too Short

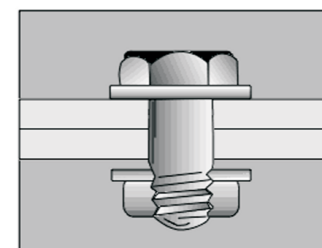

Bolt Length Too Long

AMf03011

Figure 3-11.—Correct and incorrect grip lengths.

short, the threads of the bolt will extend into the bolt hole and may act like a reamer when the material is vibrating. To prevent this, make certain that no more than two threads extend into the bolt hole. Also make certain that any threads that enter the bolt hole extend only into the thicker member that is being fastened. If the grip is too long, the nut will run out of threads before it can be tightened. In this event, a bolt with a shorter grip should be used, or if the bolt grip extends only a short distance through the hole, a washer may be used.

A second bolt dimension that must be considered is diameter. Figure 3-10 shows that the diameter of the bolt is the thickness of its shaft. If this thickness is 1/4 of an inch or more, the bolt diameter is usually given in fractions of an inch; for example, 1/4, 5/16, 7/16, and 1/2. However, if the bolt is less than 1/4 of an inch thick, the diameter is usually expressed as a whole number. For instance, a bolt that is 0.190 inch in diameter is called a No. 10 bolt, while a bolt that is 0.164 inch in diameter is called a No. 8.

The results of using a bolt of the wrong diameter should be obvious. If the bolt is too big, it cannot enter the bolt hole. If the diameter is too small, the bolt has too much play in the bolt hole, and the chances are that it is not as strong as the correct bolt.

The third and fourth bolt dimensions that should be considered when choosing a bolt replacement are head thickness and width. If the head is too thin or too

narrow, it may not be strong enough to bear the load imposed on it. If the head is too thick or too wide, it may extend so far that it interferes with the movement of adjacent parts.

BOLT HEADS.—The most common type of head is the hex head. See figure 3-11. This type of head may be thick for greater strength or relatively thin in order to fit in places having limited clearances. In addition, the head may be common or drilled to lockwire the bolt. A hex-head bolt may have a single hole drilled through it between two of the sides of the hexagon and still be classed as common. The drilled head-hex bolt has three holes drilled in the head, connecting opposite sides of the hex.

Seven additional types of bolt heads are shown in figure 3-12. Notice that view A shows an eyebolt, often used in flight control systems. View B shows a countersunk-head, close-tolerance bolt. View C shows an internal-wrenching bolt. Both the countersunk-head bolt and the internal-wrenching bolt have hexagonal recesses (six-sided holes) in their heads. They are tightened and loosened by use of appropriate sized Allen wrenches. View D shows a clevis bolt with its characteristic round head. This head may be slotted, as shown, to receive a common screwdriver or recessed to receive a Reed-and-Prince or a Phillips screwdriver.

View E shows a torque-set wrenching recess that has four driving wings, each one offset from the one opposite it. There is no taper in the walls of the recess.

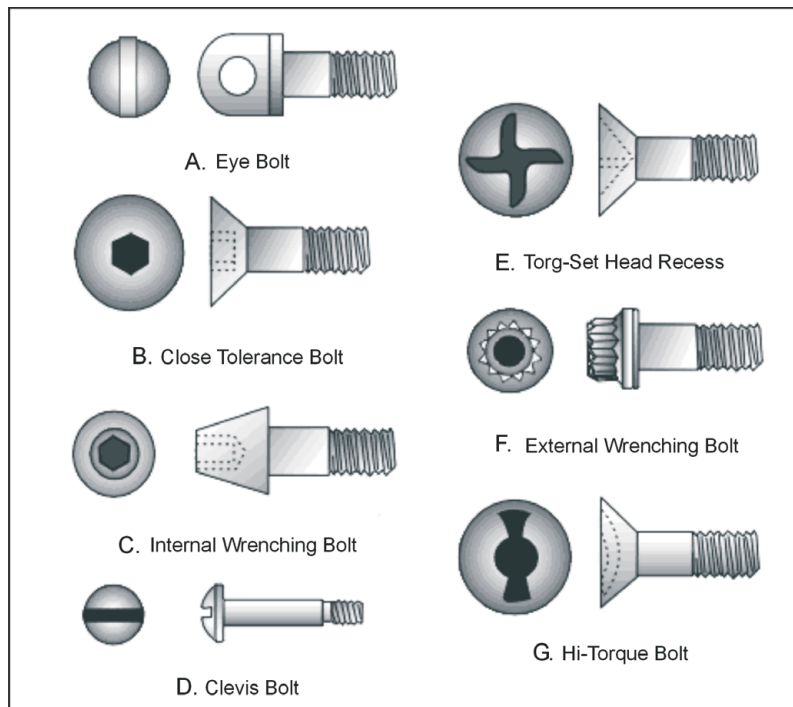

Figure 3-12.—Bolt Heads.

AM03012

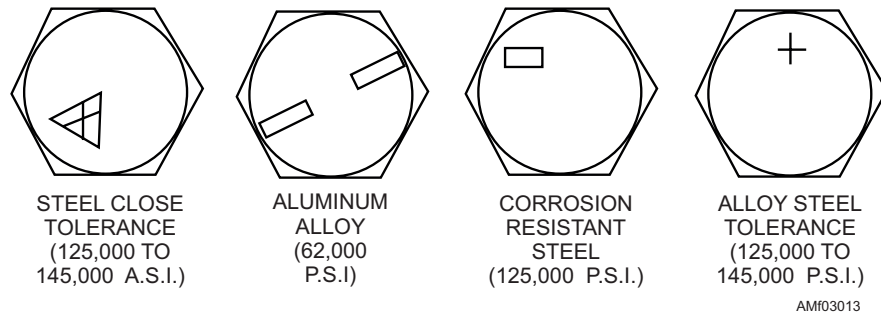

Figure 3-13.—Bolt head markings.

This permits higher torque to be applied with less tendency for the driver to slip or cam out of the slots.

View F shows an external-wrenching head that has a washer face under the head to provide an increased bearing surface. The 12-point head gives a greater wrench gripping surface.

View G shows a hi-torque style driving slot. This single slot is narrower at the center than at the outer portions. This and the center dimple provide the slot with a bow tie appearance. The recess is also undercut in a taper from the center to the outer ends, producing an inverted keystone shape. These bolts must be installed with a special hi-torque driver adapter. They must also be driven with some type of torque-limiting or torque-measuring device. Each diameter of bolt requires the proper size of driver for that particular bolt. The bolts are available in standard and reduced 100-degree flush heads. The reduced head requires a driver one size smaller than the standard head.

BOLT THREADS.—Another structural feature in which bolts may differ is threads. These usually come in one of two types: coarse and fine. The two are not interchangeable. For any given size of bolt there is a different number of coarse and fine threads per inch. For instance, consider the 1/4-inch bolts. Some are called 1/4-28 bolts because they have 28 fine threads per inch. Others have only 20 coarse threads per inch and are called 1/4-20 bolts. To force one size of threads into another size, even though both are 1/4 of an inch, can strip the finer threads or softer metal. The same thing is true concerning the other sizes of bolts; therefore, make certain that bolts you select have the correct type of threads.

BOLT MATERIALS.—The type of metal used in an aircraft bolt helps to determine its strength and its resistance to corrosion. Therefore, make certain that material is considered in the selection of replacement bolts. Like solid shank rivets, bolts have distinctive head markings that help to identify the material from

which they are manufactured. Figure 3-13 shows the tops of several hex-head bolts, each marked to indicate the type of bolt material.

BOLT IDENTIFICATION.—Unless current directives specify otherwise, every unserviceable bolt should be replaced with a bolt of the same type. Of course, substitute and interchangeable items are sometimes available, but the ideal fix is a bolt-for-bolt replacement. The part number of a needed bolt may be obtained by referring to the illustrated parts breakdown (IPB) for the aircraft concerned. Exactly what this part number means depends upon whether the bolt is AN (Air Force-Navy), NAS (National Aircraft Standard), or MS (Military Standard).

AN Part Numbers.—There are several classes of AN bolts, and in some instances their part numbers reveal slightly different types of information. However, most AN numbers contain the same type of information.

Figure 3-14 shows a breakdown of a typical AN bolt part number. Like the AN rivets discussed earlier, it starts with the letters AN. Next, notice that a number follows the letters. This number usually consists of two digits. The first digit (or absence of it) shows the class of the bolt. For instance, in figure 3-14, the series number has only one digit, and the absence of one digit

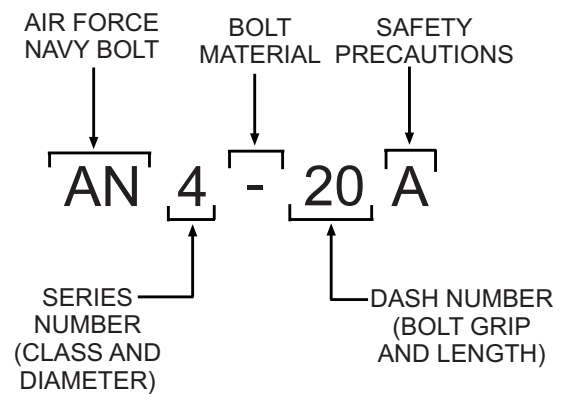

Figure 3-14.—AN bolt part number breakdown.

shows that this part number represents a general-purpose hex-head bolt. However, the part numbers for some bolts of this class have two digits. In fact, general-purpose hex-head bolts include all part numbers beginning with AN3, AN4, and so on, through AN20. Other series numbers and the classes of bolts they represent are as follows:

AN21 through AN36—clevis bolts

AN42 through AN49—eyebolts

The series number shows another type of information other than bolt class. With a few exceptions, it indicates bolt diameter in sixteenths of an inch. For instance, in figure 3-14, the last digit of the series number is 4; therefore, this bolt is 4/16 of an inch (1/4 of an inch) in diameter. In the case of a series number ending in 0, for instance AN30, the 0 stands for 10, and the bolt has a diameter of 10/16 of an inch (5/8 of an inch).

Refer again to figure 3-14, and observe that a dash follows the series number. When used in the part numbers for general-purpose AN bolts, clevis bolts, and eyebolts, this dash indicates that the bolt is made of carbon steel. With these types of bolts, the letter *C*, used in place of the dash, means corrosion-resistant steel. The letter *D* means 2017 aluminum alloy. The letters *DD* stand for 2024 aluminum alloy. For some bolts of this type, a letter *H* is used with these letters or with the dash. If it is so used, the letter *H* shows that the bolt has been drilled for safetying.

Next, observe the number 20 that follows the dash. This is called the dash number. It represents the bolt's grip (as taken from special tables). In this instance the number 20 stands for a bolt that is 2 1/32 inches long.

The last character in the AN number shown in figure 3-14 is the letter *A*. This signifies that the bolt is not drilled for cotter pin safetying. If no letter were used after the dash number, the bolt shank would be drilled for safetying.

MS Part Number.—MS is another series of bolts used in aircraft construction. In the part number shown in figure 3-15, the MS indicates that the bolt is a Military Standard bolt. The series number (20004) indicates the bolt class and diameter in sixteenths of an inch (internal-wrenching, 1/4-inch diameter). The letter *H* before the dash number indicates that the bolt has a drilled head for safetying. The dash number (9) indicates the bolt grip in sixteenths of an inch.

NAS Part Number.—Another series of bolts used in aircraft construction is the NAS. See figure 3-16.

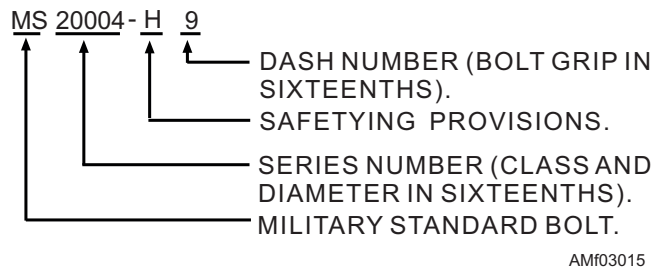

Figure 3-15.—MS bolt part number breakdown.

In considering the NAS144-25 bolt (special internal-wrenching type), observe that the bolt identification code starts with the letters *NAS*. Next, the series has a three-digit number, 144. The first two digits (14) show the class of the bolt. The next number (4) indicates the bolt diameter in sixteenths of an inch. The dash number (25) indicates bolt grip in sixteenths of an inch.

Nuts

Aircraft nuts differ in design and material, just as bolts do, because they are designed to do a specific job with the bolt. For instance, some of the nuts are made of cadmium-plated carbon steel, stainless steel, brass, or aluminum alloy. The type of metal used is not identified by markings on the nuts themselves. Instead, the material must be recognized from the luster of the metal.

Nuts also differ greatly in size and shape. In spite of these many and varied differences, they all fall under one of two general groups: self-locking and nonself-locking. Nuts are further divided into types such as plain nuts, castle nuts, check nuts, plate nuts, channel nuts, barrel nuts, internal-wrenching nuts, external-wrenching nuts, shear nuts, sheet spring nuts, wing nuts, and Klincher locknuts.

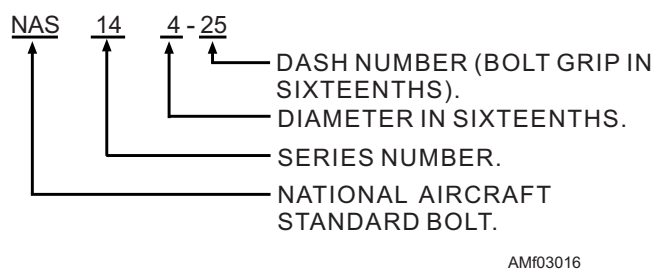

Figure 3-16.—NAS bolt part number breakdown.

NONSELF-LOCKING

NUTS.—Nonself-locking nuts require the use of a separate locking device for security of installation. There are several types of these locking devices mentioned in the following paragraphs in connection with the nuts on which they are used. Since no single locking device can be used with all types of nonself-locking nuts, you must select one suitable for the type of nut being used.

SELF-LOCKING NUTS.—Self-locking nuts provide tight connections that will not loosen under vibrations. Self-locking nuts approved for use on aircraft meet critical strength, corrosion-resistance, and temperature specifications. The two major types of self-locking nuts are prevailing torque and free spinning. The two general types of prevailing torque nuts are the all-metal nuts and the nonmetallic insert nuts. New self-locking nuts must be used each time components are installed in critical areas throughout the entire aircraft, including all flight, engine, and fuel control linkage and attachments. The flexloc nut is an example of the all-metal type. The elastic stop nut is an example of the nonmetallic insert type. All-metal self-locking nuts are constructed with the threads in the load-carrying portion of the nut out of phase with the threads in the locking portion, or with a saw cut top portion with a pinched-in thread. The locking action of these types depends upon the resiliency of the metal when the locking section and load-carrying section are forced into alignment when engaged by the bolt or screw threads.

PLAIN HEX NUTS.—These nuts are available in self-locking or nonself-locking styles. When the

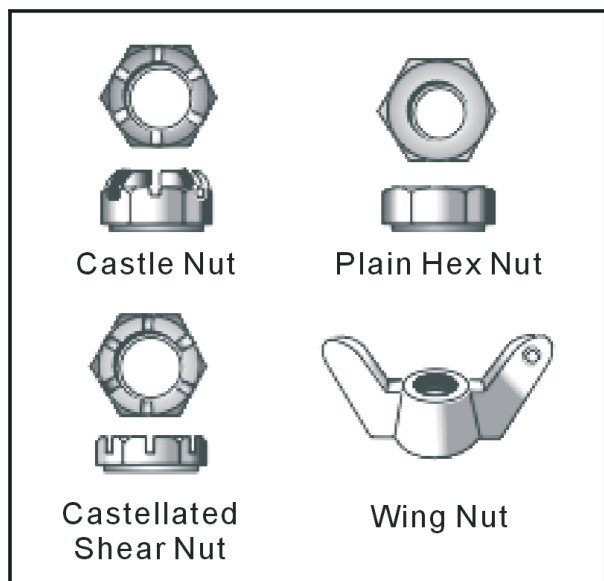

Figure 3-17.—Nuts.

AMf03017

nonself-locking nuts are used, they should be locked with an auxiliary locking device such as a check nut or lock washer. See figure 3-17.

CASTLE NUTS.—These nuts are used with drilled shank bolts, hex-head bolts, clevis bolts, eyebolts, and drilled-head studs. These nuts are designed to be secured with cotter pins or safety wire.

CASTELLATED NUTS.—Like the castle nuts, these nuts are castellated for safetying. They are not as strong or cut as deep as the castle nuts.

CHECK NUTS.—These nuts are used in locking devices for nonself-locking plain hex nuts, setscrews, and threaded rod ends.

PLATE NUTS.—These nuts are used for blind mounting in inaccessible locations and for easier maintenance. They are available in a wide range of sizes and shapes. One-lug, two-lug, and right-angle shapes are available to accommodate the specific physical requirements of nut locations. Floating nuts provide a controlled amount of nut movement to compensate for subassembly misalignment. They can be either self-locking or nonself-locking. See figure 3-18.

CHANNEL NUTS.—These nuts are used in applications requiring anchored nuts equally spaced around openings such as access and inspection doors and removable leading edges. Straight or curved channel nut strips offer a wide range of nut spacing and provide a multinut unit that has all the advantages of floating nuts. They are usually self-locking.

BARREL NUTS.—These nuts are installed in drilled holes. The round portion of the nut fits in the drilled hole and provides a self-wrenching effect. They are usually self-locking.

INTERNAL-WRENCHING NUTS.—These nuts are generally used where a nut with a high tensile

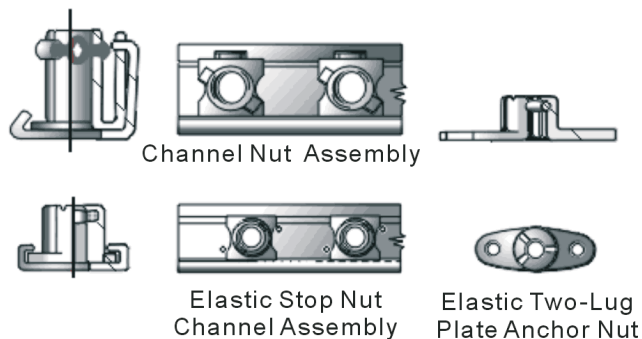

Figure 3-18.—Self-locking plate nuts.

AMf03018

strength is required or where space is limited and the use of external-wrenching nuts would not permit the use of conventional wrenches for installation and removal. This is usually where the bearing surface is counterbored. These nuts have a nonmetallic insert that provides the locking action.

POINT WRENCHING NUTS.—These nuts are generally used where a nut with a high tensile length is required. These nuts are installed with a small socket wrench. They are usually self-locking.

SHEAR NUTS.—These nuts are designed for use with devices such as drilled clevis bolts and threaded taper pins that are normally subjected to shearing stress only. They are usually self-locking.

SHEET SPRING NUTS.—These nuts are used with standard and sheet metal self-tapping screws to support line clamps, conduit clamps, electrical equipment, and access doors. The most common types are the float, the two-lug anchor, and the one-lug anchor. The nuts have an arched spring lock that prevents the screw from working loose. They should be used only where originally used in the fabrication of the aircraft. See figure 3-19.

WING NUTS.—These nuts are used where the desired tightness is obtained by the use of your fingers and where the assembly is frequently removed.

KLINCHER LOCKNUTS.—Klincher locknuts are used to ensure a permanent and vibrationproof, bolted connection that holds solidly and resists thread wear. It will withstand extremely high or low temperatures and exposure to lubricants, weather, and compounds without impairing the effectiveness of the locking element. The nut is installed with the end that looks like a double washer toward the metal being

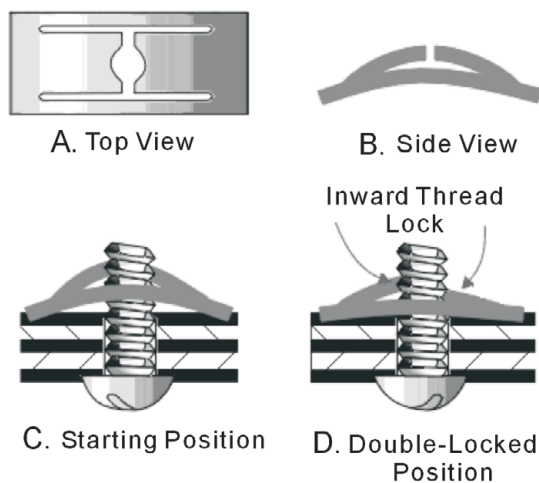

AMf03019

Figure 3-19.—Sheet spring nut.

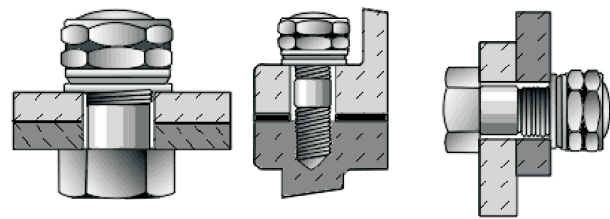

AMf03020

Figure 3-20.—Typical installations of the Klincher locknut.

fastened. Notice in figure 3-20 that the end that looks like a double hexagon is away from the metal being fastened.

Screws

The most common threaded fastener used in aircraft construction is the screw. The three most used types are the structural screw, machine screw, and the self-tapping screw.

STRUCTURAL SCREWS.—Structural screws are used for assembling structural parts. They are made of alloy steel and are heat treated. Structural screws have a definite grip length and the same shear and tensile strengths as the equivalent size bolt. They differ from structural bolts only in the type of head. These screws are available in round-head, countersunk-head, and brazier-head types, either slotted or recessed for the various types of screwdrivers. See figure 3-21.

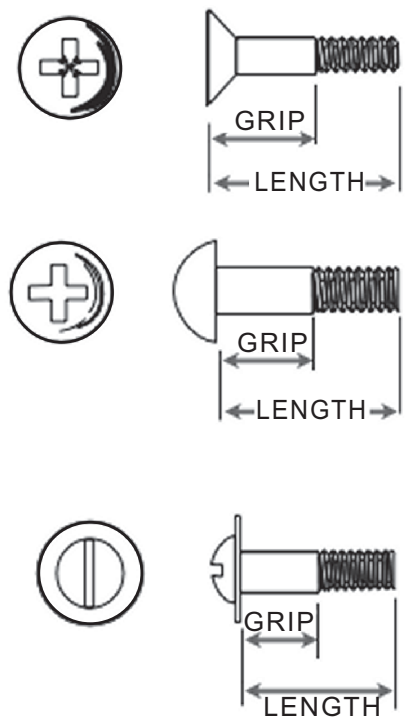

AMf03021

Figure 3-21.—Structural screws.

MACHINE SCREWS.—The commonly used machine screws are the flush-head, round-head, fillister-head, socket-head, pan-head and truss-head types.

Flush Head.—Flush-head machine screws are used in countersunk holes where a flush finish is desired. These screws are available in 82 and 100 degrees of head angle, and have various types of recesses and slots for driving.

Round Head.—Round-head machine screws are frequently used in assembling highly stressed aircraft components.

Fillister Head.—Fillister-head machine screws are used as general-purpose screws. They may also be used as cap screws in light applications, such as the attachment of cast aluminum gearbox cover plates.

Socket Head.—Socket-head machine screws are designed to be screwed into tapped holes by internal wrenching. They are used in applications that require high-strength precision products, compactness of the assembled parts, or sinking of the head into holes.

Pan and Truss Head.—Pan-head and truss-head screws are general-purpose screws used where head height is unimportant. These screws are available with cross-recessed heads only.

SELF-TAPPING SCREWS.—A self-tapping screw is one that cuts its own internal threads as it is turned into the hole. Self-tapping screws can be used only in comparatively soft metals and materials. Self-tapping screws may be further divided into two classes or groups: machine self-tapping screws and sheet metal self-tapping screws.

Machine self-tapping screws are usually used for attaching removable parts, such as nameplates, to castings. The threads of the screw cut mating threads in the casting after the hole has been predrilled. Sheet metal self-tapping screws are used for such purposes as temporarily attaching sheet metal in place for riveting. They may also be used for permanent assembly of nonstructural parts, where it is necessary to insert screws in blind applications.

CAUTION

Self-tapping screws should never be used to replace standard screws, nuts, or rivets in the original structure. Over a period of time, vibration and stress will loosen this type of fastener, causing it to lose its holding ability.

Washers

Washers such as ball socket and seat washers, taper pin washers, and washers for internal-wrenching nuts and bolts have been designed for special applications. See figure 3-22.

Ball socket and seat washers are used where a bolt is installed at an angle to the surface, or where perfect alignment with the surface is required at all times. These washers are used together.

Taper pin washers are used in conjunction with threaded taper pins. They are installed under the nut to effect adjustment where a plain washer would distort.

Washers for internal-wrenching nuts and bolts are used in conjunction with NAS internal-wrenching bolts. The washer used under the head is countersunk to seat the bolt head or shank radius. A plain washer is used under the nut.

Turnlock Fasteners

Turnlock fasteners are used to secure panels that require frequent removal. These fasteners are available in several different styles and are usually referred to by the manufacturer's trade name.

CAMLOC FASTENERS.—The 4002 series Camloc fastener consists of four principal parts: the receptacle, the grommet, the retaining ring, and the stud assembly. See figure 3-23. The receptacle is an aluminum alloy forging mounted in a stamped sheet metal base. The receptacle assembly is riveted to the access door frame, which is attached to the structure of the aircraft. The grommet is a sheet metal ring held in the access panel with the retaining ring. Grommets are furnished in two types: the flush type and the protruding type. Besides serving as a grommet for the hole in the access panel, it also holds the stud assembly. The stud assembly consists of a stud, a cross pin, a

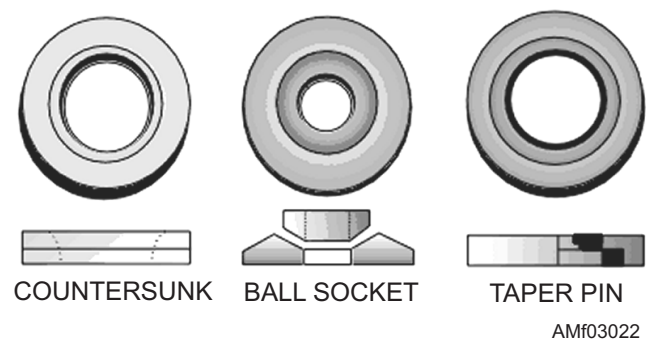
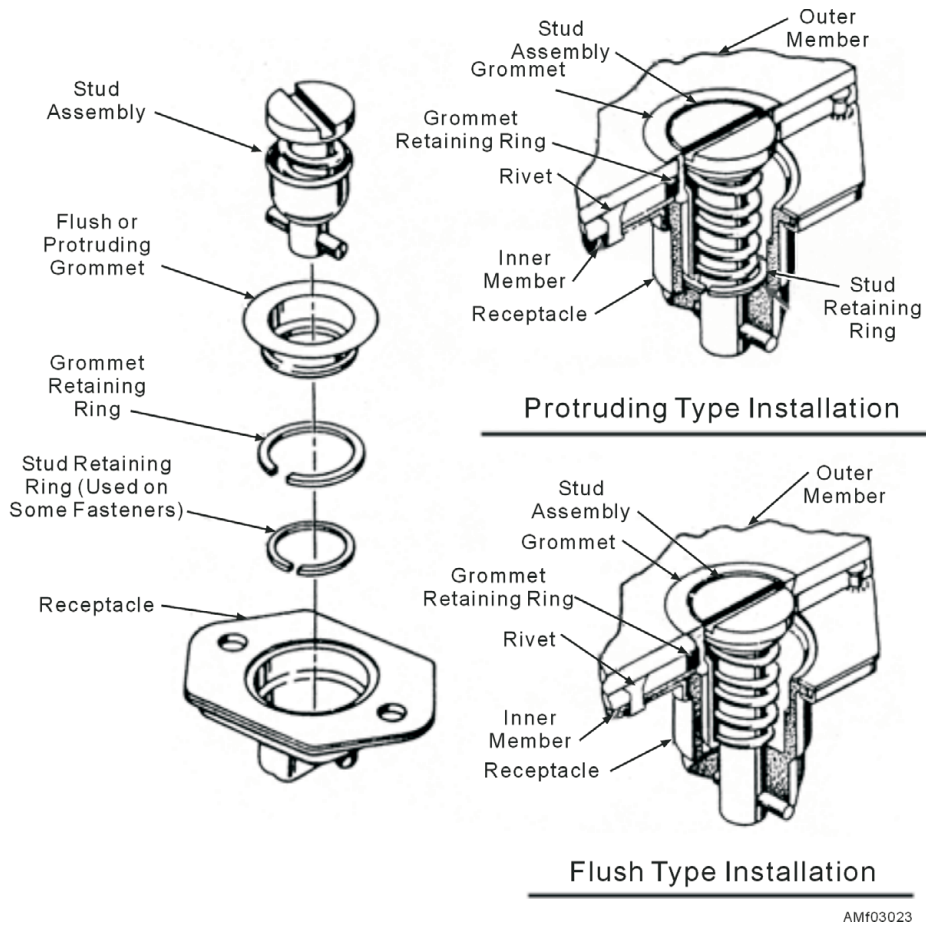

Figure 3-22.—Various types of special washers.



AMF03023

Figure 3-23.—Camloc 4002 series fastener.

spring, and a spring cup. The assembly is designed so it can be quickly inserted into the grommet by compressing the spring. Once installed in the grommet, the stud assembly cannot be removed unless the spring is again compressed.

The Camloc high-stress panel fastener, shown in figure 3-24, is a high-strength, quick-release rotary fastener, and may be used on flat or curved inside or outside panels. The fastener may have either a flush or protruding stud. The studs are held in the panel with flat

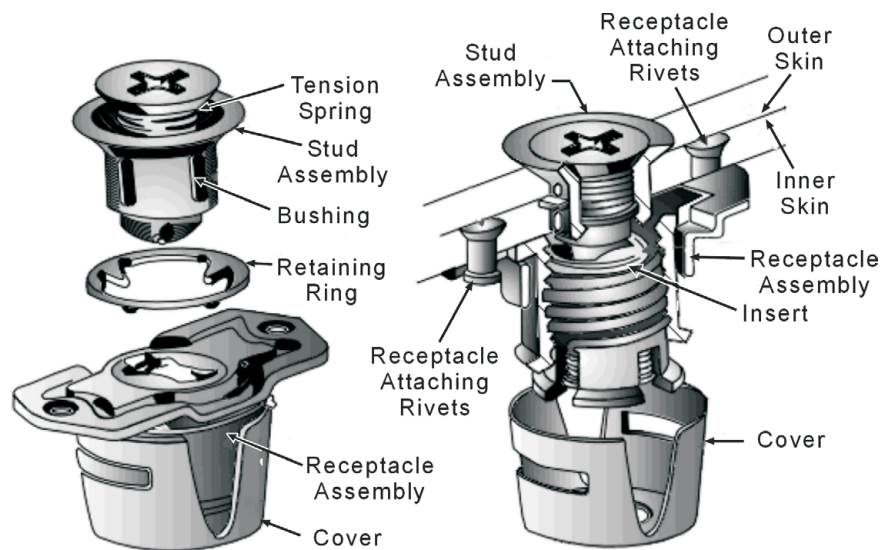

AMF03024

Figure 3-24.—Camloc high-stress panel fastener.

or cone-shaped washers—the latter being used with flush fasteners in dimpled holes. This fastener may be distinguished from screws by the deep No. 2 Phillips recess in the stud head and by the bushing in which the stud is installed.

A threaded insert in the receptacle provides an adjustable locking device. As the stud is inserted and turned counterclockwise one-half turn or more, it screws out the insert to permit the stud key to engage the insert cam when turned clockwise. Rotating the stud clockwise one-fourth turn engages the insert. Continued rotation screws the insert in and tightens the fastener. Turning the stud one-fourth turn counterclockwise will release the stud, but will not screw the insert out far enough to permit re-engagement. The stud should be turned at least one-half turn counterclockwise to reset the insert.

DZUS FASTNERS.—Dzus fasteners are available in two types. A light-duty type is used on box covers, access hole covers, and lightweight fairings. The heavy-duty type is used on cowling and heavy fairings. The main difference between the two Dzus fasteners is a grommet, which is only used on the heavy-duty fasteners. Otherwise, their construction features are about the same.

Figure 3-25 shows the parts of a light-duty Dzus fastener. Notice that they include a spring and a stud. The spring is made of cadmium-plated steel music wire, and is usually riveted to an aircraft structural member. The stud comes in a number of designs (as

shown in views A, B, and C) and mounts in a dimpled hole in the cover assembly.

When the panel is being positioned on an aircraft, the spring riveted to the structural member enters the hollow center of the stud. Then, when the stud is turned about one-fourth turn, the curved jaws of the stud slip over the spring and compress it. The resulting tension locks the stud in place and secures the panel.

Miscellaneous Fasteners

Some fasteners cannot be classified as rivets, turnlocks, or threaded fasteners. Included in this category are connectors, couplings, clamps, taper and flat-head pins, snap rings, studs, and heli-coil inserts.

FLEXIBLE CONNECTORS AND COUPLINGS.—A variety of clamping devices are used in connecting ducting sections to each other or to various components. Whenever lines, components, or ducting are disconnected or removed for any reason, you should install suitable plugs, caps, or coverings on the openings to prevent the entry of foreign materials. You should also tag the various parts to ensure correct reinstallation. You should exercise care during handling and installation to ensure that flanges are not scratched, distorted, or deformed. Flange surfaces should be free of dirt, grease, and corrosion. The protective flange caps should be left on the ends of the ducting until the installation progresses to the point where removal is necessary.

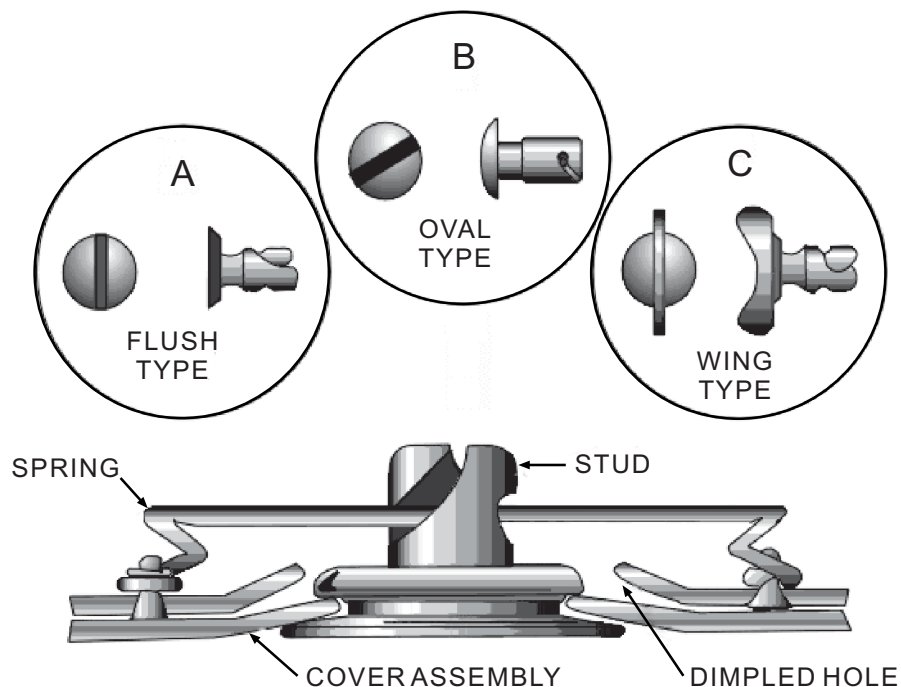

AMf03025

Figure 3-25.—Dzus fastener.

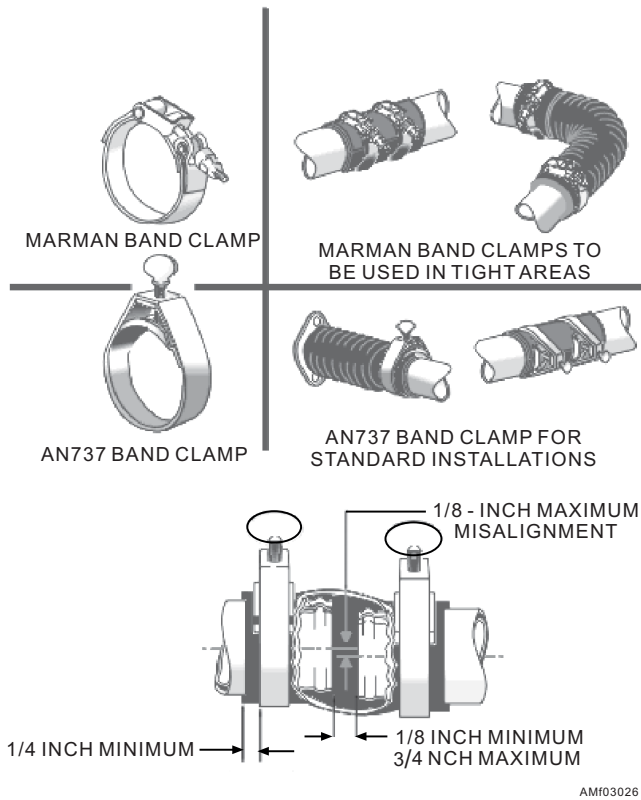

Figure 3-26.—Flexible line connectors.

In most cases it is mandatory to discard and replace seals and gaskets. You should ensure that seals and gaskets are properly seated and that mating and alignment of flanges are fitted. This will prevent the excessive torque required to close the joint, which imposes structural loads on the clamping devices. Adjacent support clamps and brackets should remain loose until installation of the coupling has been completed.

Some of the most commonly used plain-band couplings are shown in figure 3-26. When you install a hose between two duct sections, the gap between the duct ends should be a minimum of 1/8 of an inch and a maximum of 3/4 of an inch. When you install the clamps on the connection, the clamp should be 1/4 of an inch from the end of the connector. Misalignment between the ducting ends should not exceed 1/8 of an inch.

Marman clamps are commonly used in ducting systems and should be tightened to the torque value indicated on the coupling. Tighten all couplings in the manner and to the torque value specified on the clamp or in the applicable maintenance instruction manual.

When you install flexible couplings, such as the one shown in figure 3-27, the following steps are recommended to assure proper security:

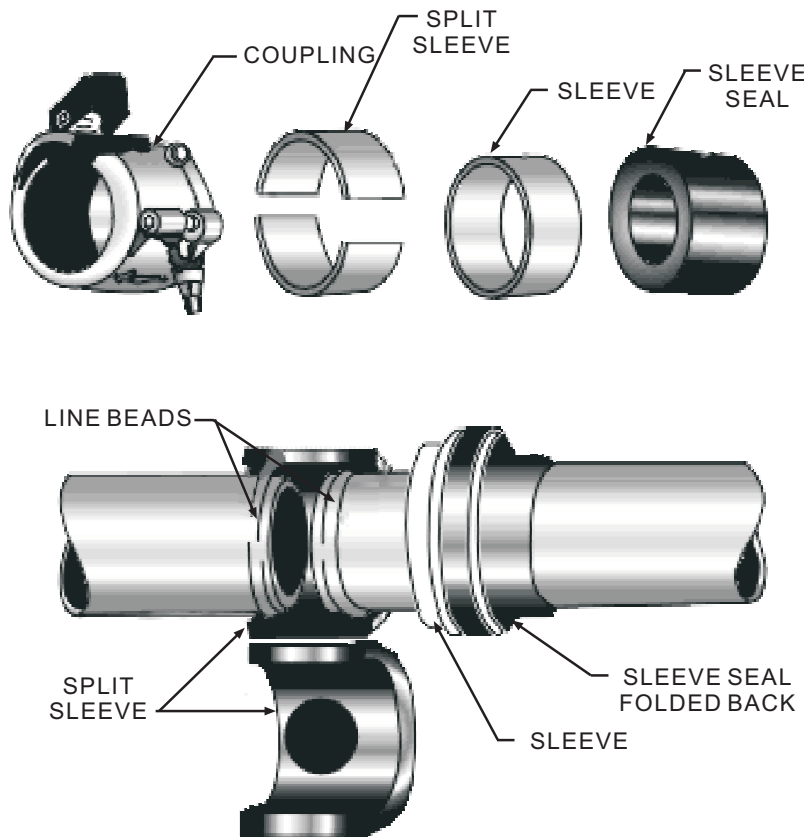

Figure 3-27.—Flexible line coupling.

1. Fold back half of the sleeve seal and slip it onto the sleeve.
2. Slide the sleeve (with the sleeve seal partially installed) onto the line.
3. Position the split sleeves over the line beads.
4. Slide the sleeve over the split sleeves, and fold over the sleeve seal so it covers the entire sleeve.
5. Install the coupling over the sleeve seal and torque to correct value.

RIGID COUPLINGS.—The rigid line coupling shown in figure 3-28 is referred to as a V-band coupling. When you install this coupling in restricted areas, some of the stiffness of the coupling can be overcome by tightening the coupling over a spare set of flanges and a gasket to the recommended torque value of the joint. Tap the coupling a few times with a plastic mallet before removing it.

When you install rigid couplings, follow the steps listed below:

1. Slip the V-band coupling over the flanged tube.
2. Place a gasket into one flange. One quick rotary motion assures positive seating of the gasket.
3. Hold the gasket in place with one hand while the mating flanged tube is assembled into the gasket to assure the seating of the mating flange to the gasket.

NOTE: View B of figure 3-28 shows the proper fitting and connecting of a rigid coupling using a metal gasket between the ducting flanges.

4. While holding the joint firmly with one hand, install the V-band coupling over the two flanges.
5. Press the coupling tightly around the flanges with one hand while engaging the latch.

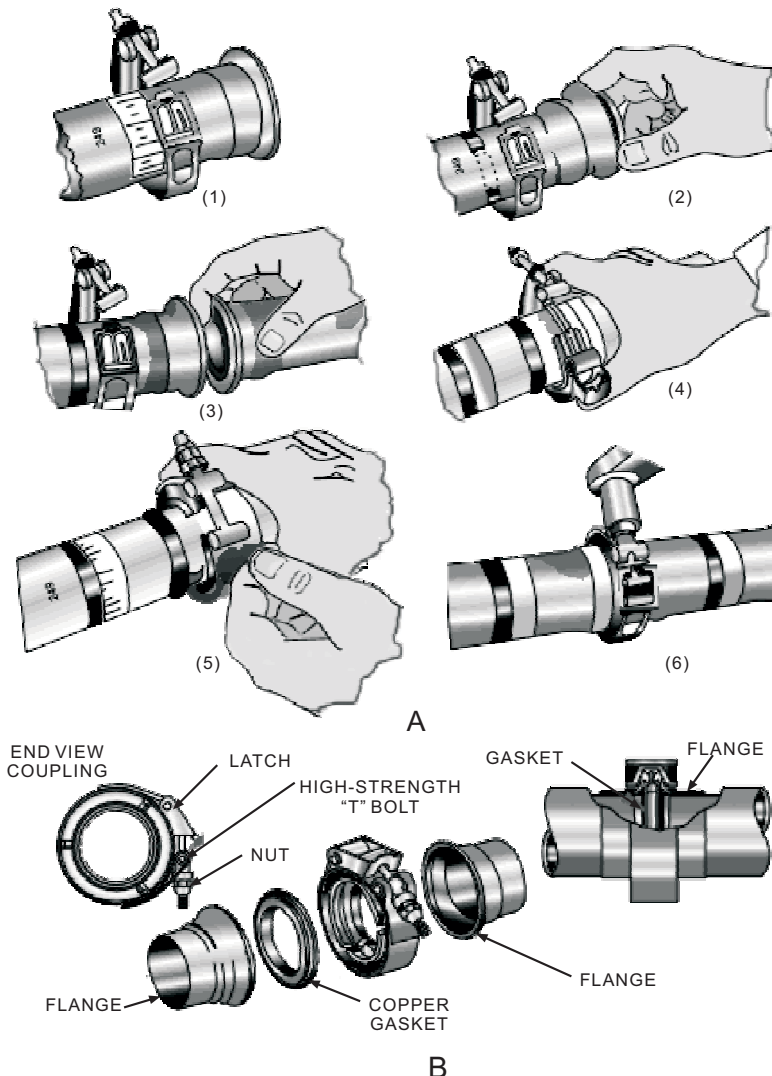

Figure 3-28.—Installation of rigid line couplings.

AMf03028



AMF03029

Figure 3-29.—Safetying a V-band coupling.

6. Tighten the coupling firmly with a ratchet wrench. Tap the outer periphery of the coupling with a plastic mallet to assure proper alignment of the flanges in the coupling. This will seat the sealing edges of the flanges in the gasket. Tighten again, making sure the recommended torque is not exceeded.

7. Check the torque of the coupling with a torque wrench and tighten until the specified torque is obtained.

8. Safety wire the V-band coupling, as shown in figure 3-29, as an extra measure of security in the event of T-bolt failure. The safety wire will be installed through the band loops that retain the T-bolt and the trunnion or quick coupler. A minimum of two turns of the wire is required. Most V-band connectors will use a T-bolt with some type of self-locking nut.

TAPER PINS.—Taper pins are used in joints that carry shear loads and where the absence of clearance is essential. See figure 3-30. The threaded taper pin is used with a taper pin washer and a shear nut if the taper pin is drilled, or with a self-locking nut if undrilled. When a shear nut is used with the threaded taper pin and washer, the nut is secured with a cotter pin.

FLAT-HEAD PINS.—The flat-head pin is used with tie rod terminals or secondary controls that do not operate continuously. The flat-head pin should be secured with a cotter pin. The pin is normally installed with the head up. See figure 3-30. This precaution is taken to maintain the flat-head pin in the installed position in case of cotter pin failure.

SNAP RINGS.—A snap ring is a ring of metal, either round or flat in cross section, that is tempered to have springlike action. This springlike action will hold

the snap ring firmly seated in a groove. The external types are designed to fit in a groove around the outside of a shaft or cylinder. The internal types fit in a groove inside a cylinder. Special pliers are designed to install each type of snap ring.

Snap rings can be reused as long as they retain their shape and springlike action. External snap rings may be safety wired, but internal types are never safety wired.

STUDS.—There are four types of studs used in aircraft structural applications. They are the coarse thread, fine thread, stepped and locking studs. Studs

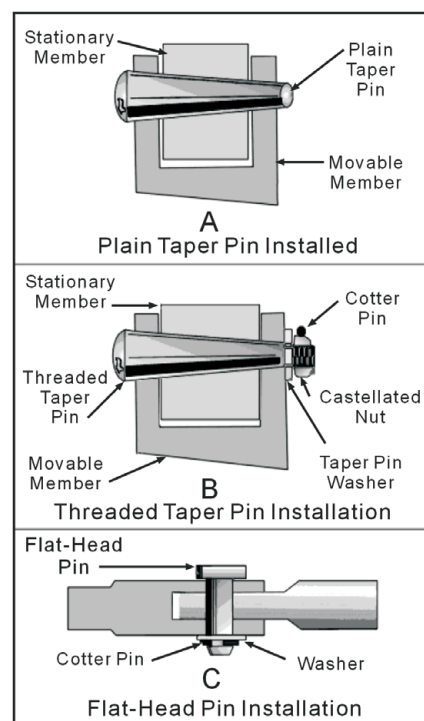

AMF03030

Figure 3-30.—Types of aircraft pins.

may be drilled or undrilled on the nut end. Coarse (NAS183) and fine (NAS184) thread studs are manufactured from alloy steel and are heat-treated. They have identical threads on both ends. The stepped stud has a different thread on each end of the stud. The locking stud may be substituted for undersize or oversize studs. The locking on this stud prevents it from backing out due to vibration, stress, or temperature variations. Refer to the *Structural Hardware Manual*, NAVAIR 01-1A-8, for more detailed information on studs.

HELI-COIL INSERTS.—Heli-coil thread inserts are primarily designed to be used in materials that are not suitable for threading because of their softness. The inserts are made of a diamond cross-sectioned stainless steel wire that is helically coiled and, in its finished form, is similar to a small, fully compressed spring. There are two types of heli-coil inserts. See figure 3-31. One is the plain insert, made with a tang that forms a portion of the bottom coil offset, and is used to drive the insert. This tang is left on the insert after installation, except when its removal is necessary to provide clearance for the end of the bolt. The tang is notched to break off from the body of the insert, thereby providing full penetration for the fastener.

The second type of insert used is the self-locking, mid-grip insert, which has a specially formed grip coil

midway on the insert. This produces a gripping effect on the engaging screw. For quick identification, the self-locking, mid-grip inserts are dyed red.

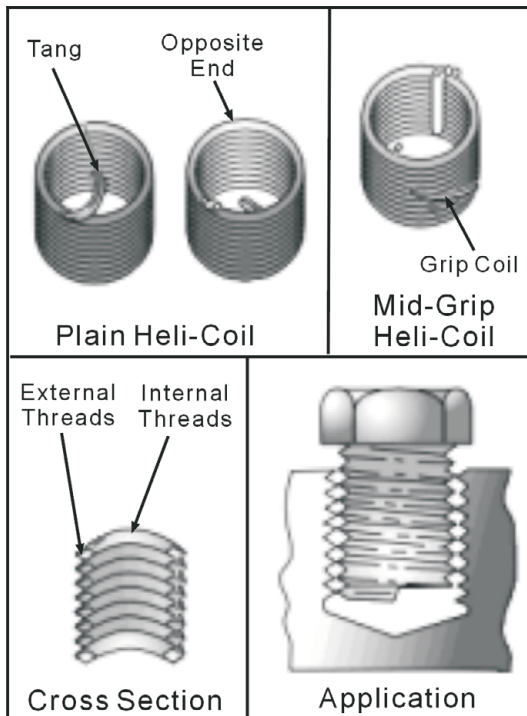

AMF03031

Figure 3-31.—Heli-coil insert.

- Q3-7. *What fastener has a shear and tensile strength at least equal to the requirements of AN and NAS bolts?*
- Q3-8. *A 4002 series Camloc fastener consists of what total number of principal parts?*
- Q3-9. *What metal is used in the construction of threaded pins of Hi-lok fasteners?*
- Q3-10. *Jo-bolts are available in what three head styles?*
- Q3-11. *How many threads must be extending through the nut of a replacement bolt for it to be considered the correct length?*
- Q3-12. *What type of wrench is used to loosen or tighten countersunk-head and internal-wrenching bolts?*
- Q3-13. *How many times can a self-locking nut be reused?*
- Q3-14. *What type of nut is designed to be used with a cotter pin or safety wire?*
- Q3-15. *What type of nut is used on an assembly that is frequently removed?*
- Q3-16. *What type of nut is used to ensure a permanent and vibration proof connection?*
- Q3-17. *What three types of screws are most commonly used in aircraft construction?*
- Q3-18. *What type of screw is as strong as a bolt of the same size?*
- Q3-19. *Flush-head machine screws are available in what degree(s) of head angle?*
- Q3-20. *What type of screw should NOT be used when replacing an original screw in an aircraft structure?*
- Q3-21. *When should a ball socket and seat washer be used on a bolt?*
- Q3-22. *When you install a hose between two duct sections, what is the maximum allowable gap between the duct ends?*
- Q3-23. *If the correct torque value is not specified on a Marman clamp, what manual should you consult to locate the correct torque value?*

CABLES

A cable is a group of wires or a group of strands of wires twisted together into a strong wire rope. The wires or strands may be twisted in various ways. The relationship of the direction of twist of each strand to each other and to the cable as a whole is called the *lay*. The lay of the cable is an important factor in its strength. If the strands are twisted in a direction opposite to the twist of the strands around the center strand or core, the cable will not stretch (or set) as much as one in which they are all twisted in the same direction. This direction of twist (in opposite direction) is most commonly adopted, and it is called a *regular* or an *ordinary lay*. Cables may have a right regular lay or a left regular lay. If the strands are twisted in the direction of twist around the center strand or core, the lay is called a *lang lay*. There is a right and left lang lay. The only other twist arrangement—twisting the strands alternately right and left, and then twisting them all either to the right or to the left about the core—is called a *reverse lay*. Most aircraft cables have a right regular lay.

When aircraft cables are manufactured, each strand is first formed to the spiral or helical shape to fit the position it is to occupy in the finished cable. The process of such forming is called *preforming*, and cables made by such a process are said to be *preformed*. The process of preforming is adopted to ensure flexibility in the finished cable and to relieve bending and twisting stresses in the strands as they are woven into the cable. It also keeps the strands from spreading when the cable is cut. All aircraft cables are internally lubricated during construction.

Aircraft control cables are fabricated either from flexible, preformed carbon steel wire or from flexible, preformed, corrosion-resistant steel wire. The small corrosion-resistant steel cables are made of steel

containing not less than 17 percent chromium and 8 percent nickel, while the larger ones (those of the 5/16-, 3/8-, and 7/16-inch diameters) are made of steel that, in addition to the amounts of chromium and nickel just mentioned, also contains not less than 1.75 percent molybdenum.

Cables may be designated 7×7 , 7×19 , or 6×19 according to their construction. A 7×7 cable consists of six strands of seven wires each, laid around a center strand of seven wires. A 7×19 cable consists of six strands of 19 wires, laid around a 19-wire central strand. A 6×19 IWRC cable consists of six strands of 19 wires each, laid around an independent wire rope center.

The size of cable is given in terms of diameter measurement. A 1/8-inch cable or a 5/16-inch cable means that the cable measures 1/8 inch or 5/16 inch in diameter, as shown in figure 3-32. Note that the cable diameter is that of the smallest circle that would enclose the entire cross section of the cable. Aircraft control cables vary in diameters, ranging from 1/16 of an inch to 3/8 of an inch.

Fittings

Cable ends may be equipped with several different types of fittings such as terminals, thimbles, bushings, and shackles. Terminal fittings are generally of the swaged type. Terminal fittings are available with threaded ends, fork ends, eye ends, and single-shank and double-shank ball ends.

Threaded-end, fork-end, and eye-end terminals are used to connect the cable to turnbuckles, bell cranks, and other linkage in the system. The ball terminals are used for attaching cable to quadrants and special connections where space is limited. The single-shank ball end is usually used on the ends of cables, and the double-shank ball end may be used at either the ends or

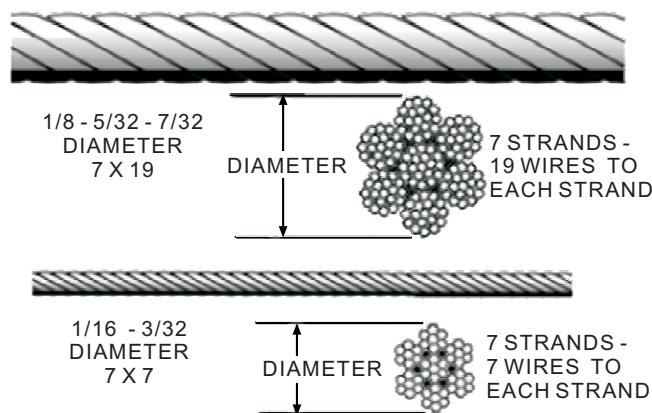

AM03032

Figure 3-32.—Cable cross section.

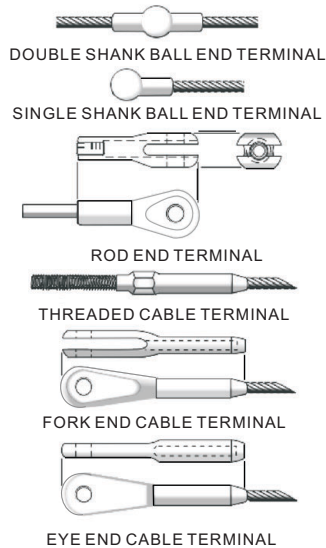

Figure 3-33.—Types of cable terminal fittings.

in the center of a cable run. Figure 3-33 shows the various types of terminal fittings.

Thimble, bushing, and shackle fittings may be used in place of some types of terminal fittings when facilities and supplies are limited and immediate replacement of the cable is necessary. Figure 3-34 shows these fittings.

Turnbuckles

A turnbuckle is a mechanical screw device that consists of two threaded terminals and a threaded barrel. Figure 3-35 shows a typical turnbuckle assembly. Turnbuckles are fitted in the cable assembly for the purpose of making minor adjustments in cable length and for adjusting cable tension. One of the terminals has right-hand threads and the other has left-hand threads. The barrel has matching right- and left-hand threads internally. The end of the barrel, with left-hand threads inside, can usually be identified by either a groove or knurl around the end of the barrel. Barrels and terminals are available in both long and short lengths.

When you install a turnbuckle in a control system, it is necessary to screw both of the terminals an equal number of turns into the turnbuckle barrel. It is also

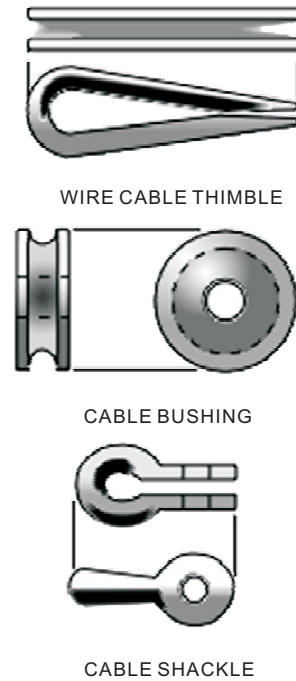

Figure 3-34.—Thimble, bushing, and shackle fittings.

essential that all turnbuckle terminals be screwed into the barrel at least until not more than three threads are exposed. On initial installation, the turnbuckle terminals should not be screwed inside the turnbuckle barrel more than four threads. Figure 3-36 shows turnbuckle thread tolerances.

After a turnbuckle is properly adjusted, it must be safetied. There are several methods of safetying turnbuckles. However, only two methods have been adopted as standard procedures by the services: the clip-locking (preferred) method and the wire-wrapping method.

Adjustable Connector Links

An adjustable connector link consists of two or three metal strips with holes so arranged that they may be matched and secured with a clevis bolt to adjust the length of the connector. They are installed in cable assemblies for the purpose of making major adjustments in cable length and to compensate for cable stretch. Adjustable connector links are usually used in very long cable assemblies.

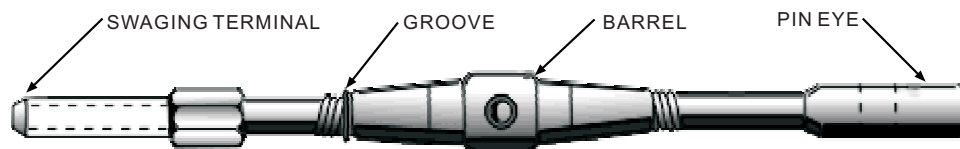

Figure 3-35.—Typical turnbuckle assembly.

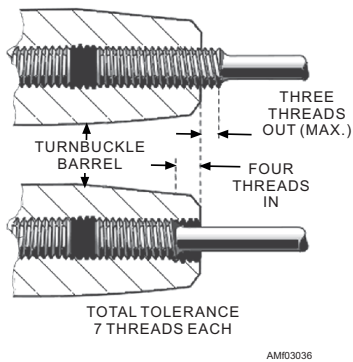

Figure 3-36.—Turnbuckle tolerances.

GUIDES

Fairleads (rubstrips), grommets, pressure seals, and pulleys are all types of cable guides. They are used to protect control cables by preventing the cables from rubbing against nearby metal parts. They are also used as supports to reduce cable vibration in long stretches (runs) of cable. Figure 3-37 shows some typical cable guides.

Fairleads

Fairleads may be made of a solid piece of material to completely encircle cables when they pass through holes in bulkheads or other metal parts. Fairleads may be used to reduce cable whipping and vibration in long runs of cable. Split fairleads are made for easy installation around single cables to protect them from rubbing on the edges of holes.

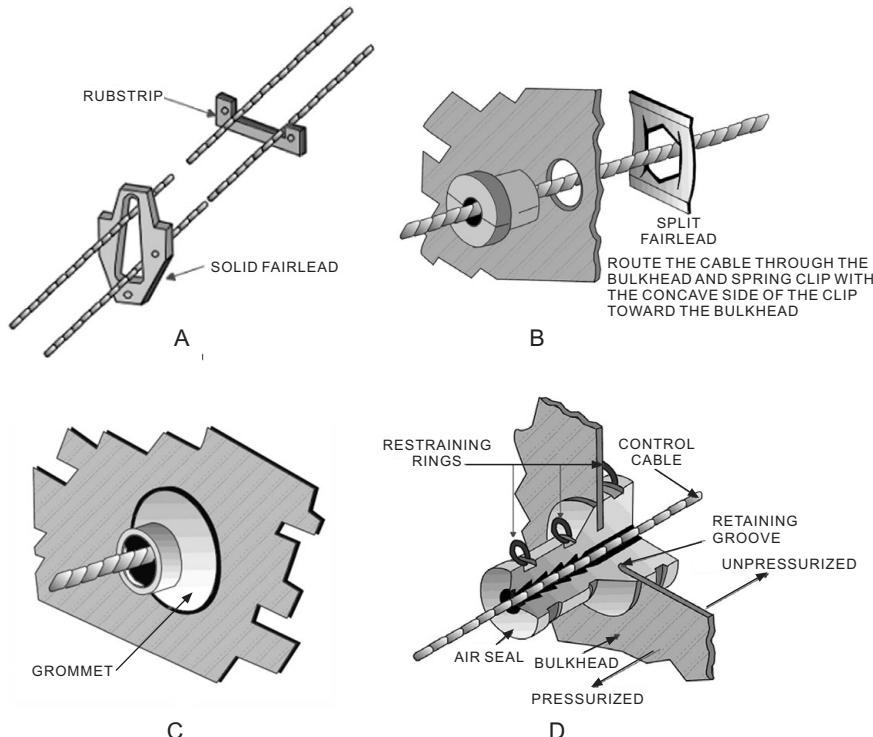

Figure 3-37.—Typical cable guides.

Grommets

Grommets are made of rubber, and they are used on small openings where single cables pass through the walls of unpressurized compartments.

Pressure Seals

Pressure seals are used on cables or rods that must move through pressurized bulkheads. They fit tightly enough to prevent air pressure loss, but not so tightly as to hinder movement of the unit.

Pulleys

Pulleys (or sheaves) are grooved wheels used to change cable direction and to allow the cable to move with a minimum of friction. Most pulleys used on aircraft are made from layers of cloth impregnated with phenolic resin and fused together under high temperatures and pressures. Aircraft pulleys are extremely strong and durable, and cause minimum wear on the cable passing over them. Pulleys are provided with grease-sealed bearings, and usually do not require further lubrication. However, pulley bearings may be pressed out, cleaned, and relubricated with special equipment. This is usually done only by depot-level maintenance activities.

Pulley brackets made of sheet or cast aluminum are required with each pulley installed in the aircraft.

See figure 3-38. Besides holding the pulley in the correct position and at the correct angle, the brackets prevent the cable from slipping out of the groove on the pulley wheel.

SECTORS AND QUADRANTS

These units are generally constructed in the form of an arc or in a complete circular form. They are grooved around the outer circumference to receive the cable, as shown in figure 3-38. The names sector and quadrant are used interchangeably. Sectors and quadrants are similar to bell cranks and walking beams, which are used for the same purpose in rigid control systems.

- Q3-24. Where space is limited, what type of fitting is used to connect a cable to a quadrant?
- Q3-25. A turnbuckle barrel with internal left-hand threads can be identified by what means?
- Q3-26. What is the total thread tolerance for a turnbuckle assembly?
- Q3-27. What type of cable guide should be used for a small opening where a single cable passes through a wall separating unpressurized compartments?

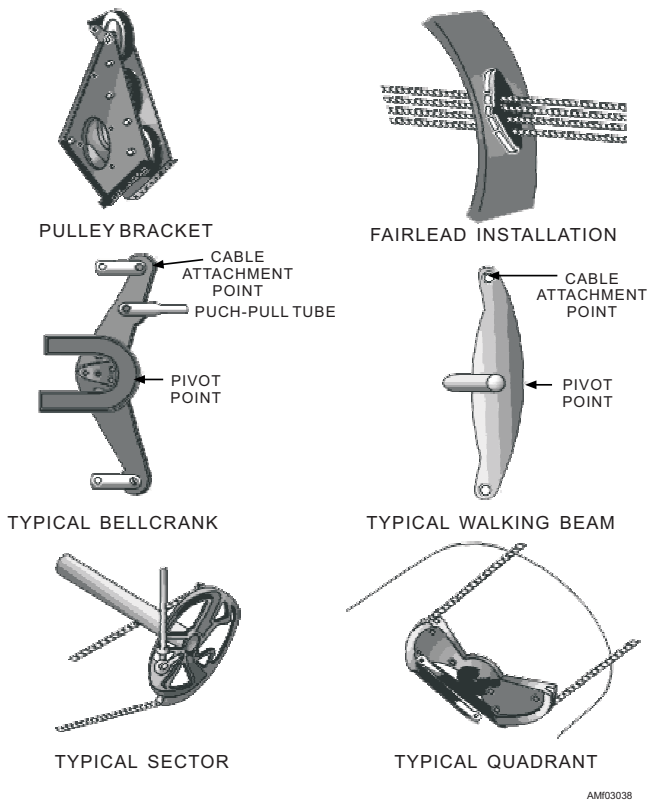

Figure 3-38.—Control system components.

AIRCRAFT ELECTRICAL HARDWARE

LEARNING OBJECTIVE: Recognize the different types of common electrical hardware used on naval aircraft.

An important part of aircraft electrical maintenance is determining the correct type of electrical hardware for a given job. These maintenance functions normally require a joint effort on the part of the AM and the AE/AT personnel. You must become familiar with wire and cable, connectors, terminals, and bonding and bonding devices.

WIRE AND CABLE

For purposes of electrical installations, a wire is described as a stranded conductor covered with an insulating material. The term *cable*, as used in aircraft electrical installations, includes the following:

- Two or more insulated conductors contained in the same jacket (multiconductor cable)
- Two or more insulated conductors twisted together (twisted pair)
- One or more insulated conductors covered with a metallic braided shield (shielded cable)
- A single insulated conductor with a metallic braided outer conductor (RF cable)

For wire replacement work, the aircraft maintenance instruction manual (MIM) should be consulted first. The manual normally lists the wire used in a given aircraft.

CONNECTORS

Connectors are devices attached to the ends of cables and sets of wires to make them easier to connect and disconnect. Each connector consists of a plug assembly and a receptacle assembly. The two assemblies are coupled by means of a coupling nut. Each consists of an aluminum shell containing an insulating insert that holds the current-carrying contacts. The plug is usually attached to the cable end, and is the part of the connector on which the coupling nut is mounted. The receptacle is the half of the connector to which the plug is connected. It is usually mounted on a part of the equipment. One type of connector commonly used in aircraft electrical systems is shown in figure 3-39.

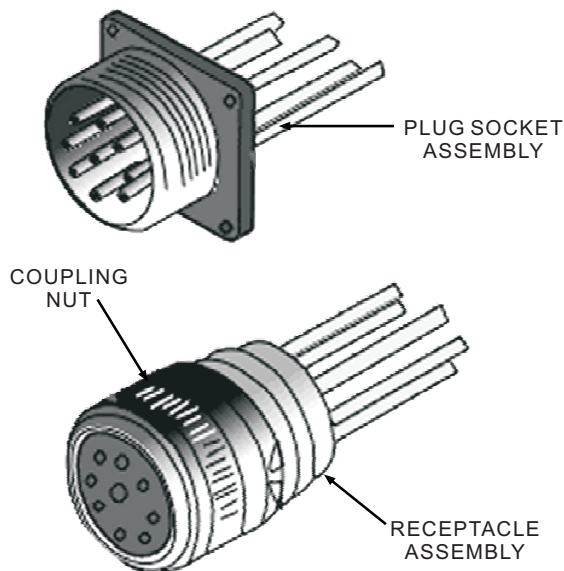

Figure 3-39.—Connector assembly.

AMf03039

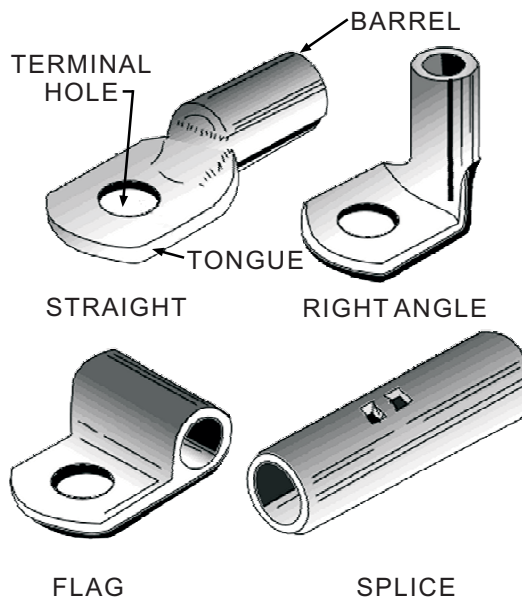

Figure 3-40.—Basic types of solderless terminals.

AMf03040

TERMINALS

Since most aircraft wires are stranded, it is necessary to use terminal lugs to hold the strands together. This allows a means of fastening the wires to terminal studs. The terminals used in electrical wiring are either of the soldered or crimped type. Terminals used in repair work must be of the size and type specified in the applicable maintenance instruction manual. The solderless crimped-type terminals are generally recommended for use on naval aircraft. Soldered-type terminals are usually used in emergencies only.

The basic types of solderless terminals are shown in figure 3-40. They are the straight, right angle, flag, and splice types. There are variations of these types.

BONDING

An aircraft can become highly charged with static electricity while in flight. If the aircraft is improperly bonded, all metal parts do not have the same amount of static charge. A difference of potential exists between the various metal surfaces. If the resistance between insulated metal surfaces is great enough, charges can accumulate. The potential difference could become high enough to cause a spark. This constitutes a fire hazard and also causes radio interference. If lightning strikes an aircraft, a good conducting path for heavy current is necessary to minimize severe arcing and sparks.

When you connect all the metal parts of an aircraft to complete an electrical unit, it is called bonding.

Bonding connections are made of screws, nuts, washers, clamps, and bonding jumpers. Figure 3-41 shows a typical bonding link installation.

Bonding also provides the necessary low-resistance return path for single-wire electrical systems. This low-resistance path provides a means of bringing the entire aircraft to the earth's potential when it is grounded.

Whenever you perform an inspection, both bonding connections and safetying devices must be inspected with great care.

STATIC DISCHARGERS

Static dischargers are commonly known as *static wicks* or *static discharge wicks*. They are used on aircraft to allow the continuous satisfactory operation of onboard navigation and radio communication systems. During adverse charging conditions, they

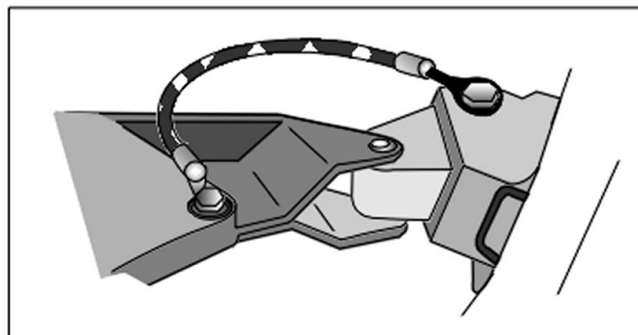

Figure 3-41.—Typical bonding link installation.

AMf03041

limit the potential static buildup on the aircraft and control interference generated by static charge. Static dischargers are not lightning arrestors and do not reduce or increase the likelihood of an aircraft being struck by lightning. Static dischargers are subject to damage or significant changes in resistance characteristics as a result of lightning strike to the aircraft, and should be inspected after a lightning strike to ensure proper static discharge operation.

Static dischargers are fabricated with a wick of wire or a conductive element on one end, which provides a high-resistance discharge path between the aircraft and the air. See figure 3-42. They are attached on some aircraft to the ailerons, elevators, rudder, wing, horizontal and vertical stabilizer tips, etc. Refer to your aircraft's MIM for maintenance procedures.

- Q3-28. What manual should you first consult when replacing an aircraft wire?
- Q3-29. What type of terminal is generally recommended for use on naval aircraft?
- Q3-30. What device is used on naval aircraft to allow the continuous satisfactory operation of onboard electrical equipment?

TORQUING OF FASTENERS

LEARNING OBJECTIVE: Recognize the importance of the proper torquing of fasteners. Identify the required torquing procedures.

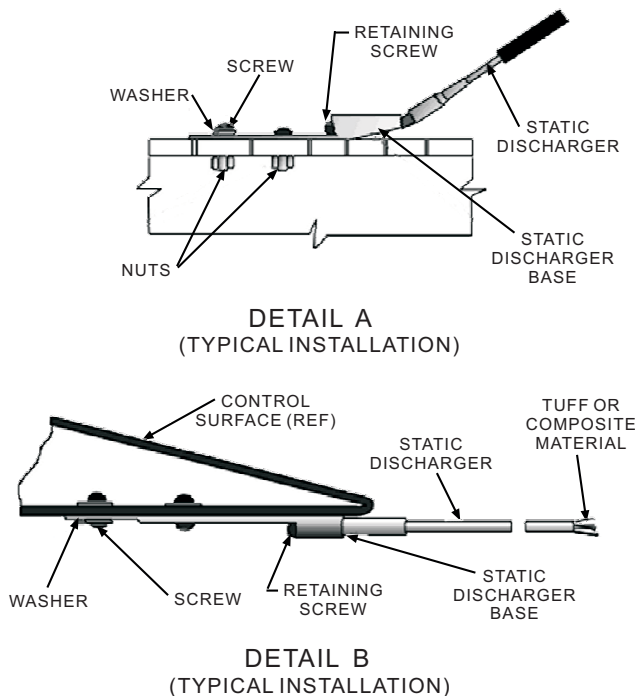

Figure 3-42.—Typical static dischargers.

Fastener fatigue failure accounts for the majority of all fastener problems. Fatigue breaks are caused by insufficient tightening and the lack of proper preload or clamping force. This results in movement between the parts of the assembly and bending back and forth or cyclic stressing of the fastener. Eventually, cracks will progress to the point where the fastener can no longer support its designed load. At this point the fastener fails with varying consequences.

TYPES OF TORQUE WRENCHS

The two most commonly used torque wrenches are the dial or beam indicating type and the setting type.

Dial or Beam Indicating Type

These torque wrenches measure change in applied torque through a deflecting member. A dial or digital read out is located below the handle to permit convenient and accurate reading. Indicating torque wrenches operate in clockwise and counterclockwise directions.

Setting Type

These wrenches compare the applied load to a self-contained standard. Reset is automatic upon release of applied load.

TORQUING PROCEDURES

For the nut to properly load the bolt and prevent premature failure, a designated amount of torque must be applied. Proper torque reduces the possibility of the fastener loosening while in service. The correct torque to apply when you are tightening an assembly is based on many variables. The fastener is subjected to two stresses when it is tightened. These stresses are torsion and tension. Tension is the desired stress, while torsion is the undesirable stress caused by friction. A large percentage of applied torque is used to overcome this friction, so that only tension remains after tightening. Proper tension reduces the possibility of fluid leaks.

The recommended torque values provided in table 3-2 have been established for average dry, cadmium-plated nuts for both the fine and coarse thread series of nuts. Thread surface variations such as paint, lubrication, hardening, plating, and thread distortion may alter these values considerably. The torque values must be followed unless the MIM or structural repair manual for the specific aircraft requires a specific torque for a given nut. Torque values vary slightly with

Table 3-2.—Recommended Torque Values (Inch-Pounds)

CAUTION				
THE FOLLOWING TORQUE VALUES ARE DERIVED FROM OIL-FREE CADMIUM PLATED THREADS.				
	TORQUE LIMITS RECOMMENDED FOR INSTALLATION (BOLTS LOADED PRIMARILY IN SHEAR)	MAXIMUM ALLOWABLE TIGHTENING TORQUE LIMITS		
Tap Size	Tension type nuts MS20365 and AN310 (40,000 psi in bolts)	Shear type nuts MS20364 and AN320 (24,000 psi in bolts)	Nuts MS20365 and AN310 (90,000 psi in bolts)	Nuts MS20364 and AN320 (54,000 psi in bolts)
FINE THREAD SERIES				
8-36	12-15	7-9	20	12
10-32	20-25	12-15	40	25
1/4-28	50-70	30-40	100	60
5/16-24	100-140	60-85	225	140
3/8-24	160-190	95-110	390	240
7/16-20	450-500	270-300	840	500
1/2-20	480-690	290-410	1100	660
9/16-18	800-1000	480-600	1600	960
5/8-18	1100-1300	600-780	2400	1400
3/4-16	2300-2500	1300-1500	5000	3000
7/8-14	2500-3000	1500-1800	7000	4200
1-14	3700-5500	2200-3300*	10,000	6000
1-1/8-12	5000-7000	3000-4200*	15,000	9000
1-1/4-12	9000-11,000	5400-6600*	25,000	15,000
COARSE THREAD SERIES				
8-32	12-15	7-9	20	12
10-24	20-25	12-15	35	21
1/4-20	40-50	25-30	75	45
5/16-18	80-90	48-55	160	100
3/8-16	160-185	95-100	275	170
7/16-14	235-255	140-155	475	280
1/2-13	400-480	240-290	880	520
9/16-12	500-700	300-420	1100	650
5/8-11	700-900	420-540	1500	900
3/4-10	1150-1600	700-950	2500	1500
7/8-9	2200-3000	1300-1800	4600	2700
<p>The above torque values may be used for all cadmium-plated steel nuts of the fine or coarse thread series which have approximately equal number of threads and equal face bearing areas.</p> <p>*Estimated corresponding values.</p>				

manufacturers. When the torque values are included in a technical manual, these values take precedence over the standard torque values provided in the *Structural Hardware Technical Manual*, NAVAIR 01-1A-8.

Separate torque tables and torquing considerations are provided in NAVAIR 01-1A-8 for the large variety of nuts, bolts, and screws used in aircraft construction. You should use this manual when specific torque values are not provided as a part of the removal/replacement instructions.

To obtain values in foot-pounds, divide inch-pound values by 12. Do not lubricate nuts or bolts except for corrosion-resistant steel parts or where specifically instructed to do so. Always tighten by rotating the nut first if possible. When space considerations make it necessary to tighten the fastener by rotating the bolt head, approach the high side of the indicated torque range. Do not exceed the maximum allowable torque value. Maximum torque ranges should be used only when materials and surfaces being joined are of sufficient thickness, area, and strength to resist breaking, warping, or other damage.

For corrosion-resisting steel nuts, use the torque values given for shear-type nuts. The use of any type of drive-end extension on a torque wrench changes the dial reading required to obtain the actual values indicated in the torque range tables. See figure 3-43.

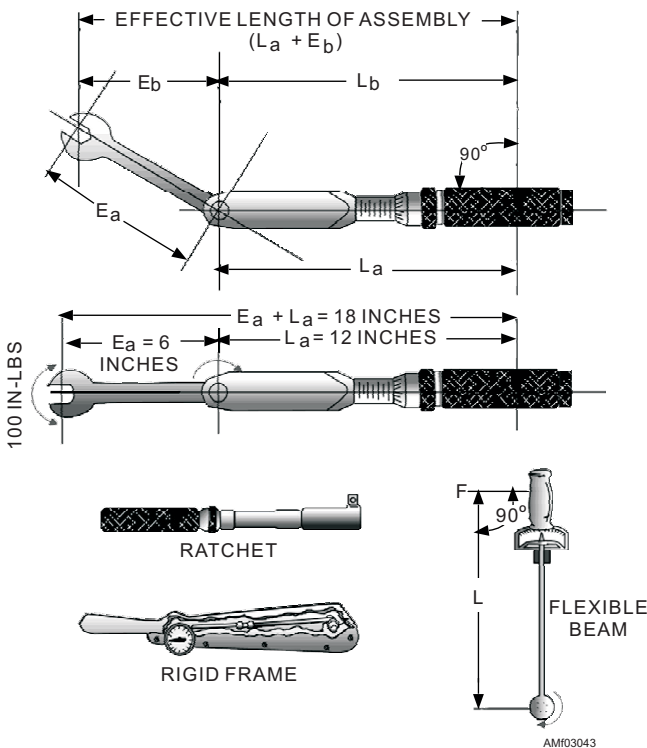

Figure 3-43.—Torque wrenches.

TORQUING COMPUTATION

When you are using a drive-end extension, the torque wrench reading must be computed using the formula in figure 3-44:

$$S = \frac{T \times L_a}{L_a + E_a}$$

Figure 3-44.—Drive-end extension formula.

Where:

S = handle setting or reading

T = torque applied at end of adapter

L_a = length of handle in inches

E_a = length of extension in inches

If you desire to exert 100 inch-pounds at the end of the wrench and extension, when L_a equals 12 inches and E_a equals 6 inches, it is possible to determine the handle setting by making the calculation shown in figure 3-45.

$$S = \frac{T \times L_a}{L_a + E_a}$$

$$S = \frac{100 \times 12}{12 + 6}$$

$$S = \frac{1200}{18}$$

$$S = 66.7 \text{ inch-pounds}$$

Figure 3-45.—Sample calculation.

Whenever possible, attach the extension in line with the torque wrench. When it is necessary to attach the extension at an angle to the torque wrench, the effective length of the assembly will be $L_a + E_a$, as shown in figure 3-43. In this instance, length E_b must be substituted for length E_a in the formula.

NOTE: It is not advisable to use a handle extension on a flexible beam-type torque wrench at any time. The use of a drive-end extension on any type of torque wrench makes use of the formula necessary. When the formula has been used, force must be applied to the handle of the torque wrench at the point from which the measurements were taken. If this is not done, the torque obtained will be in error.

Q3-31. What are the two most commonly used types of torque wrenches?

Q3-32. What manual provides torquing information for a large variety of nuts, bolts, and screws used in aircraft construction?

AIRCRAFT SAFETYING METHODS

LEARNING OBJECTIVE: Identify the various safety methods used on aircraft hardware.

You will come in contact with many different types of safetying materials. These materials are used to stop rotation and other movement of fasteners. They are also used to secure other equipment that may come loose due to vibration in the aircraft.

COTTER PINS

Cotter pins are used to secure bolts, screws, nuts, and pins. Some cotter pins are made of low-carbon steel, while others consist of stainless steel and are more resistant to corrosion. Also, stainless steel cotter pins may be used in locations where nonmagnetic material is required. Regardless of shape or material, all cotter pins are used for the same general purpose—safetying. Figure 3-46 shows three types of cotter pins and how their size is determined.

NOTE: Whenever uneven prong cotter pins are used, the length measurement is to the end of the shortest prong.

SAFETY WIRE

Safety wire comes in many types and sizes. You must first select the correct type and size of wire for the job. Annealed corrosion-resistant wire is used in

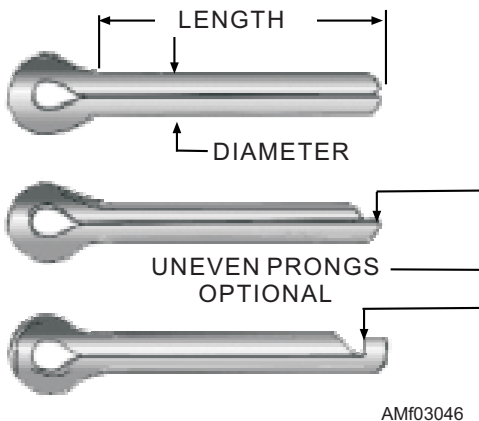

Figure 3-46.—Types of cotter pins.

high-temperature, electrical equipment and aircraft instrument applications. All nuts except the self-locking types must be safetied; the method used depends upon the particular installation.

Figure 3-47 shows various methods commonly used in safety wiring nuts, bolts, and screws. Examples 1, 2, and 5 of figure 3-47 show the proper method of safety wiring bolts, screws, square head plugs, and similar parts when wired in pairs. Examples 6 and 7 show a single-threaded component wired to a housing or lug. Example 3 shows several components wired in series. Example 4 shows the proper method of wiring castellated nuts and studs. Note that there is no loop around the nut. Example 8 shows several components in a closely spaced, closed geometrical pattern, using the single-wire method. The following general rules apply to safety wiring:

1. All safety wires must be tight after installation, but not under so much tension that normal handling or vibration will break the wire.
2. The wire must be applied so that all pull exerted by the wire tends to tighten the nut.
3. Twists should be tight and even, and the wire between nuts as taut as possible without overtwisting. Wire between nuts should be twisted with the hands. The use of pliers will damage the wire. Pliers may be used only for final end twist before cutting excess wire.

Annealed copper safety wire is used for sealing first aid kits, portable fire extinguishers, oxygen regular emergency valves, and other valves and levers used for emergency operation of aircraft equipment. This wire can be broken by hand in case of an emergency.

TURNBUCKLE SAFETYING

When all adjusting and rigging on the cables is completed, safety the turnbuckles as necessary. Only

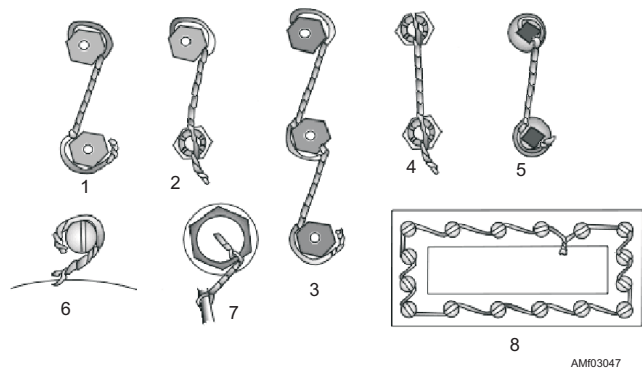

Figure 3-47.—Safety wiring methods.

two methods of safetying turnbuckles have been adopted as standard procedures by the armed services: the clip-locking (preferred) method and the wire-wrapping method (fig. 3-48).

Lock clips must be examined after assembly for proper engagement of the hook lip in the turnbuckle barrel hole by the application of slight pressure in the disengaging direction. Lock clips must not be reused, as removal of the clips from the installed position will severely damage them.

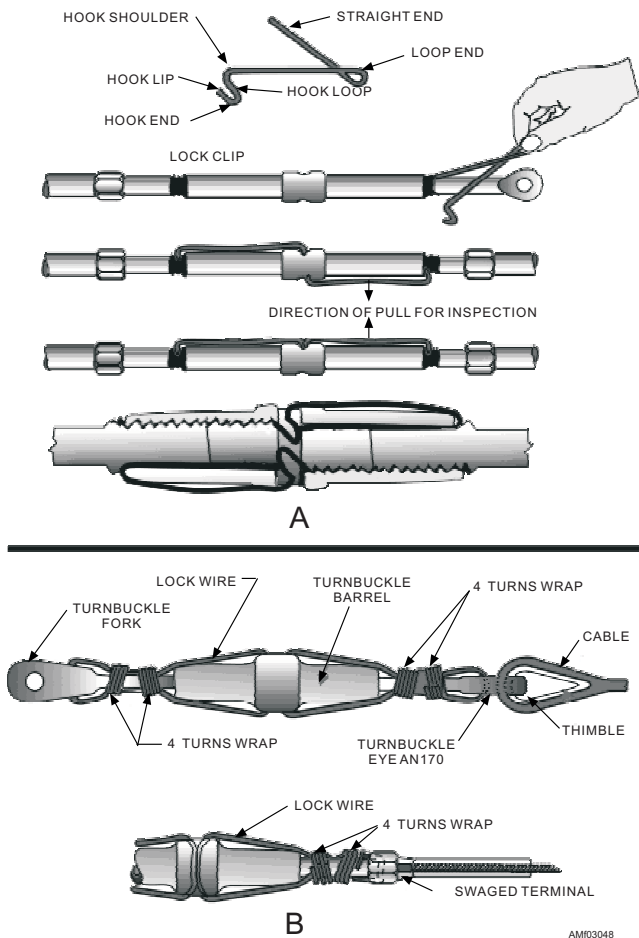

Figure 3-48.—Safetying turnbuckles: (A) Clip-locking method (preferred); (B) wire-wrapped method.

Clip-Locking Turnbuckles

The clip-locking method of safetying uses an NAS lock clip. To safety the turnbuckle, align the slot in the barrel with the slot in the cable terminal. Hold the lock clip between the thumb and forefinger at the end loop. Insert the straight end of the clip into the aperture formed by the aligned slots. Bring the hook end of the lock clip over the hole in the center of the turnbuckle barrel and seat the hook loop into the hole. Application of pressure to the hook shoulder at the hole will engage the hook lip in the turnbuckle barrel and complete the safety locking of one end. The above steps are then repeated on the opposite end of the turnbuckle barrel. Both locking clips may be inserted in the same turnbuckle barrel hole, or they may be inserted in opposite holes.

Wire-Wrapping Turnbuckles

First, two safety wires are passed through the hole in the center of the turnbuckle barrel. The ends of the wires are bent 90 degrees toward the ends of the turnbuckle, as shown in figure 3-48.

Next, the ends of the wires are passed through the holes in the turnbuckle eye or between the jaws of the turnbuckle fork, as applicable. The wires are then bent toward the center of the turnbuckle, and each one wrapped four times around the shank. This secures the wires in place.

When a swaged turnbuckle terminal is being safetied, one wire must be passed through the hole provided for this purpose in the terminal. It is then looped over the free end of the other wire, and both ends wrapped around the shank.

Q3-33. *What is the purpose of a cotter pin?*

Q3-34. *How many different methods are used to secure a turnbuckle?*

Q3-35. *How many pieces of safety wire are used to secure a turnbuckle using the wire-wrapping method?*

CHAPTER 4

AIRCRAFT METALLIC REPAIR

INTRODUCTION

Before performing aircraft metallic repair, you must be familiar with the tools, special equipment, terms, and techniques used to accomplish this type of maintenance. In the following text, we will discuss these subjects and basic sheet metal fabrication procedures as well as several different types of aircraft structural metallic repair procedures. Before you perform any type of structural repair to an aircraft, always consult the applicable aircraft Maintenance Instruction Manual (MIM).

STRUCTURAL TOOLS

LEARNING OBJECTIVE: Identify the various structural tools used for sheet metal fabrication. Identify the various structural tools used for aircraft structural repair.

You should always have a thorough knowledge of the tools of your trade. This will enable you to increase the quality of maintenance on your squadron's aircraft. One of the most important skills that you can have is the ability to use the tools that are required to complete any given task in a timely and professional manner. These tools include various hand tools, power tools, drills, and special tools.

HAND TOOLS

Before discussing the tools individually, a few comments on the care and handling of hand tools are appropriate. The condition in which you maintain your tools determines your efficiency as well as how your superiors view your day-to-day work.

Each mechanic should keep all assigned tools in the toolbox when they are not being used. Every tool should have a place, and every tool should be kept in its place. All tools should be cleaned after every use and before being placed in the toolbox. If they are not to be used again the same day, they should be oiled with a light preservative oil to prevent rusting. Tools that are being used at a workbench or at a machine should be kept within easy reach of the mechanic, but should be kept where they will not fall or be knocked to the deck.

Tools should not be placed on finished parts or machines.

There are many different types of hand tools used for aircraft metallic repair and sheet metal fabrication. In the following text, we will discuss a few of the more common types used for sheet metal fabrication. For a more detailed explanation of all of the various hand tools associated with aircraft metallic repair and sheet metal fabrication, refer to *Use and Care of Hand Tools and Measuring Devices*, NAVEDTRA 14256.

Hammers

Hammers are used to apply a striking force where the force of the hand alone is insufficient. Each of the hammers discussed in this section is composed of a head and a handle, even though these parts differ greatly from hammer to hammer.

BALL PEEN HAMMER.—The ball peen hammer is sometimes referred to as a machinist's hammer. It is a hard-faced hammer made of forged tool steel. See figure 4-1.

The flat end of the head is called the face. This end is used for most hammering jobs. The domed end of the hammer is called the peen. The peen end is smaller in diameter than the face, and is useful for striking in areas that are too small for the face to enter.

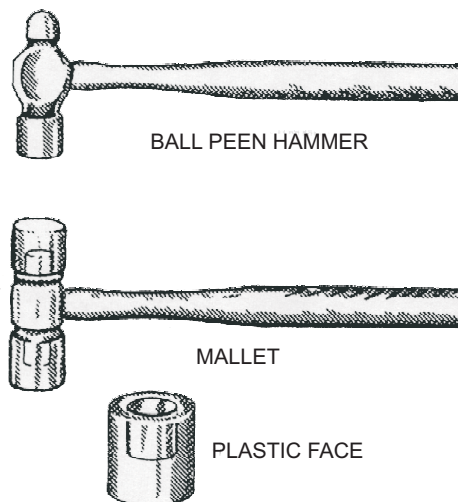

Figure 4-1.—Hammers.

AM104001

Ball peen hammers are made in different weights, usually 4, 6, 8, and 12 ounces and 1, 1 1/2, and 2 pounds. For most work, a 1 1/2-pound and a 12-ounce hammer will suffice.

MALLETS.—A mallet is a soft-faced hammer. Mallets are constructed with heads made of brass, lead, tightly rolled strips of rawhide, plastic, or plastic with a lead core for added weight.

A plastic mallet, similar to the one shown in figure 4-1, is the type normally found in the AM's toolbox. The weight of the plastic head may range from a few ounces to a few pounds; however, the size of the plastic mallet is measured across the diameter of the face. The plastic mallet may be used for straightening thin sheet ducting or for installing clamps.

Rotary Rivet Cutters

In case you cannot obtain rivets of the required length, rotary rivet cutters may be used to cut longer rivets to the desired length. See figure 4-2. When you use the rotary rivet cutter, insert the rivet part way into the correct diameter hole. Place the required number of shims (shown as staggered, notched strips in the illustration) under the head and squeeze the handles. The compound action from the handles rotates the two discs in opposite directions. The rotation of the discs shears the rivet smoothly to give the correct length (as determined by the number of shims inserted under the head). When you are using the larger cutter holes, place one of the tool handles in a vise, insert the rivet in the hole, and shear it by pulling the free handle. If this tool is not available, diagonal-cutting pliers can be used as an emergency cutter, although the sheared edges will not be as smooth and even as when they are cut with the rotary rivet cutter.

Rivet Set

A rivet set is a tool equipped with a die for driving a particular type of rivet. Rivet sets are used in both hand

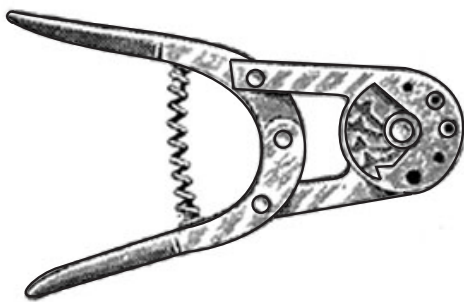

AMf04002

Figure 4-2.—Rotary rivet cutter.

and pneumatic hammer riveting methods. Rivet sets are available to fit every size and shape of rivet head. The ordinary handset is made of 1/2-inch diameter carbon steel about 6 inches long. It is knurled to prevent slipping in the hand. Only the face of the set is hardened and polished. Sets for the oval-head rivets (universal, round, and brazier) are recessed (or cupped) to fit the rivet head. When you select a rivet set, be sure that it will provide the proper clearance between the set and the sides of the rivet head and between the surfaces of the metal and the set. Flush or flat sets are used for countersunk and flat-head rivets. To set flush rivets properly, the flush sets should be at least 1 inch in diameter.

Special sets, called “draw” sets, are used to “draw up” the sheets being riveted in order to eliminate any opening between them before the rivet is bucked. Each draw set has a hole 1/32 of an inch larger than the diameter of the rivet shank for which it was made. Sometimes, especially in hand-working tools, the draw set and the rivet header are incorporated into one tool. The header consists of a hole sufficiently shallow for the set to expand the driven rivet “bucktail” and form a head on it when a hammer strikes the set. Figure 4-3 shows a rectangular-shaped hand set that combines the draw and header sets and a flush set used with a pneumatic hammer.

Sets used with pneumatic hammers (rivet guns) are provided in many sizes and shapes to fit the type and location of the rivet. These sets are the same as the hand rivet sets except that the shank is shaped to fit into the rivet gun. The sets are made of high-grade carbon tool steel and are heat-treated to provide the necessary strength and wear resistance. The tip or head of the rivet set should be kept smooth and highly polished to prevent marring of rivet heads.

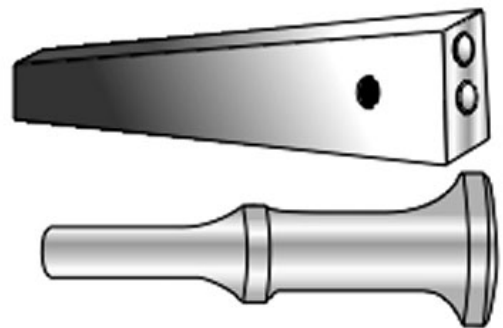

AMf04003

Figure 4-3.—Rivet sets.

Bucking Bars

Bucking bars are tools used to form bucktails (the head formed during riveting operations) on rivets. They come in many different shapes and sizes, as shown in figure 4-4. Bucking bars are normally made from an alloy steel similar to tool steel. The particular shape to be used depends upon the location and accessibility of the rivet to be driven. The size and weight of the bar depend on the size and alloy of the rivet to be driven. Under certain circumstances, and for specific rivet installations, specially designed bucking bars are manufactured locally. These bars are normally made from tool steel. The portion of the bar designed to come in contact with the rivet has a polished finish. This helps to prevent marring of formed bucktails. Bucking-bar faces must be kept smooth and perfectly flat and the edges and corners rounded.

NOTE: Never hold a bucking bar in a vise unless the vise jaws are equipped with protective covers to prevent marring of the bucking bar.

A satisfactory rivet installation depends largely on the condition of the bucking bar and your ability to use it. If possible, hold the bucking bar in such a manner that will allow the longest portion of the bar to be in line with the rivet. You should hold the bucking bar lightly

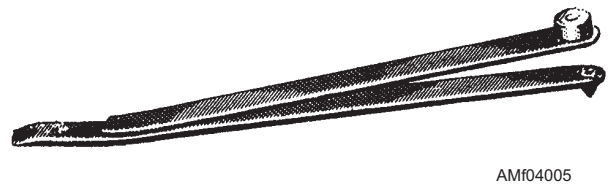

AMf04005

Figure 4-5.—Hole finder.

but firmly against the end of the rivet shank so as not to unseat the rivet head. The inertia of this tool provides the force that bucks (upsets) the rivet and forms a flat, head like bucktail.

Hole Finder

A hole finder is a tool used to transfer existing holes in aircraft structures or skin to replacement skin or patches. See figure 4-5. The tool has two leaves parallel to each other and fastened together at one end. The bottom leaf of the hole finder has a teat installed near the end of the leaf that is aligned with a bushing on the top leaf. The desired hole to be transferred is located by fitting the teat on the bottom leaf of the hole finder into the existing rivet hole. Drilling through the bushing on the top leaf makes the hole in the new part. If the hole finder is properly made, holes drilled in this manner will be perfectly aligned. A separate duplicator must be provided for each diameter of rivet to be used.

Skin Fasteners

There are several types of skin fasteners used to temporarily secure parts in position for drilling and riveting and to prevent slipping and creeping of the parts. C-clamps, machine screws, and Cleco fasteners are frequently used for this purpose. See figure 4-6.

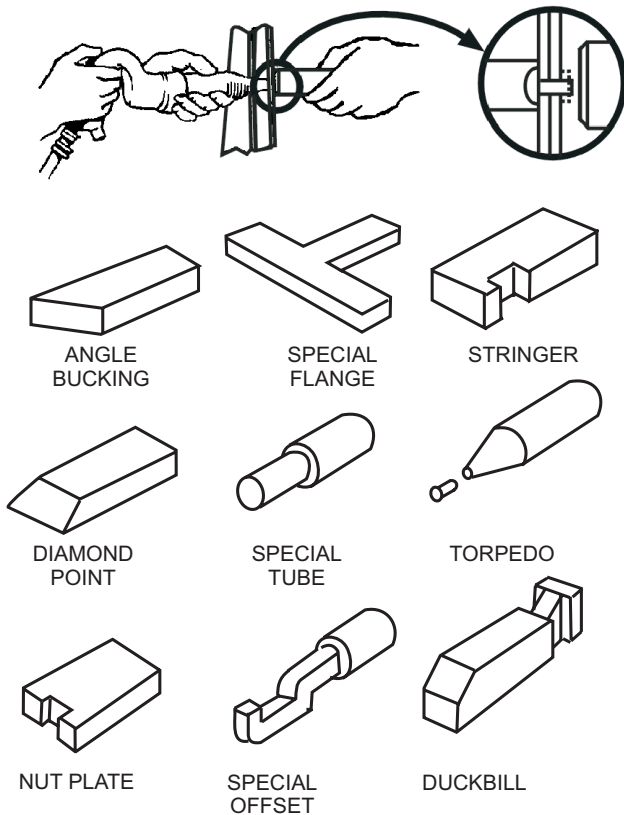

AMf04004

Figure 4-4.—Bucking bars.

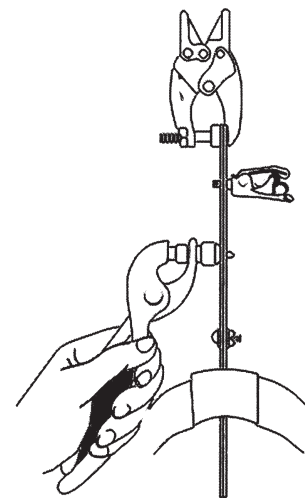

AMf04006

Figure 4-6.—Skin fasteners.

Cleco fasteners come in sizes ranging from 1/16 to 3/8 of an inch. The size is normally stamped on the fastener, but may also be recognized by the following color code:

- 1/16 inch—black
- 3/32 inch—cadmium
- 1/8 inch—copper
- 5/32 inch—black
- 3/16 inch—brass
- 1/4 inch—green
- 3/8 inch—red

The Cleco fastener is installed by compressing the spring with Cleco pliers (forceps). With the spring compressed, the pin of the Cleco is inserted in the drilled hole. The compressed spring is then released, allowing spring tension on the pin of the Cleco to draw the materials together. Clecos should be stored on a U-channel plate to protect the pins of the Cleco. Storing Clecos at random among heavy tools will result in bent pins.

Countersink

Machine countersinking is used to flush rivet sheets 0.064 of an inch and greater in thickness. A countersink has a cutting face beveled to the angle of the rivet head, and is kept centered by a pilot shaft inserted in the rivet hole. When a conventional countersink is used, you should try each hole with a rivet or screw to ensure the hole has not been countersunk too deeply. The adjustable countersink is the best tool to use because the depth of the hole can be controlled. A stopping device automatically acts as a depth gauge so that the hole will not be countersunk too deep. Figure 4-7 shows an adjustable stop countersink.

The countersink should always be equipped with a fiber collar to prevent marring of the metal surface. A drill motor or hand drill (electric or air) may be used to

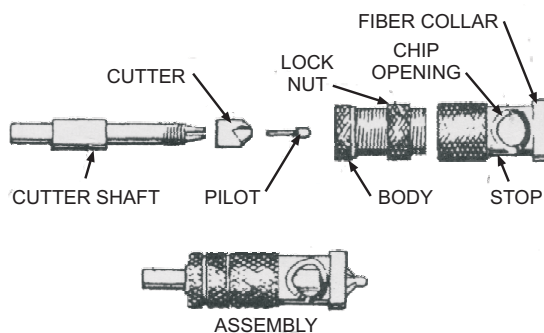

AMf04007

Figure 4-7.—Adjustable stop countersink.

operate the countersink. However, it should not be operated above 2,500 rpm. The countersink must be sharp to avoid vibration and chatter.

Snips and Shears

Snips and shears are used for cutting sheet metal and steel of various thickness and shapes. Normally, shears cuts the heavier or thicker materials.

One of the handiest tools for cutting light (up to 0.064 inch thick) sheet metal is the hand snip (tin snips). The straight snips, shown in figure 4-8, have blades that are straight and cutting edges that are sharpened to an 85-degree angle. Snips like this can be obtained in different sizes ranging from the small 6-inch to the large 14-inch snip. Tin snips will also work on slightly heavier gauges of soft metals, such as aluminum alloys.

It is hard to cut circles or small arcs with straight snips. There are snips especially designed for circular cutting. An example is the aviation snips that are available in a left-hand and right-hand cutting design.

To cut large holes in the lighter gauges of sheet metal, start the cut by punching or otherwise making a hole in the center of the area to be cut out. With aviation snips, make a spiral cut from the starting hole out toward the scribed circle, and continue cutting until the scrap falls away.

POWER TOOLS

This part of the chapter is devoted to the common types of air-driven power tools that you will use on a routine basis. You should pay attention to the safety procedures, general operating procedures, and care of these tools.

Rivet Head Shaver

The rivet-head shaver, shown in figure 4-9, is used to smooth countersunk rivet heads that protrude. The rivet head shaver is also called a “micro miller.” The depth of cut is adjustable in increments of 0.0005 of an inch on the model shown. On some models the depth of cut is adjustable in increments of 0.0008 of an inch. You can change cutters and adjust their depth without using special tools. Once the depth is set, the positive action of the serrated adjustment-locking collar prevents the loss of the setting.

You should position the cutters directly over the rivet head and hold the tool at an angle of 90 degrees to

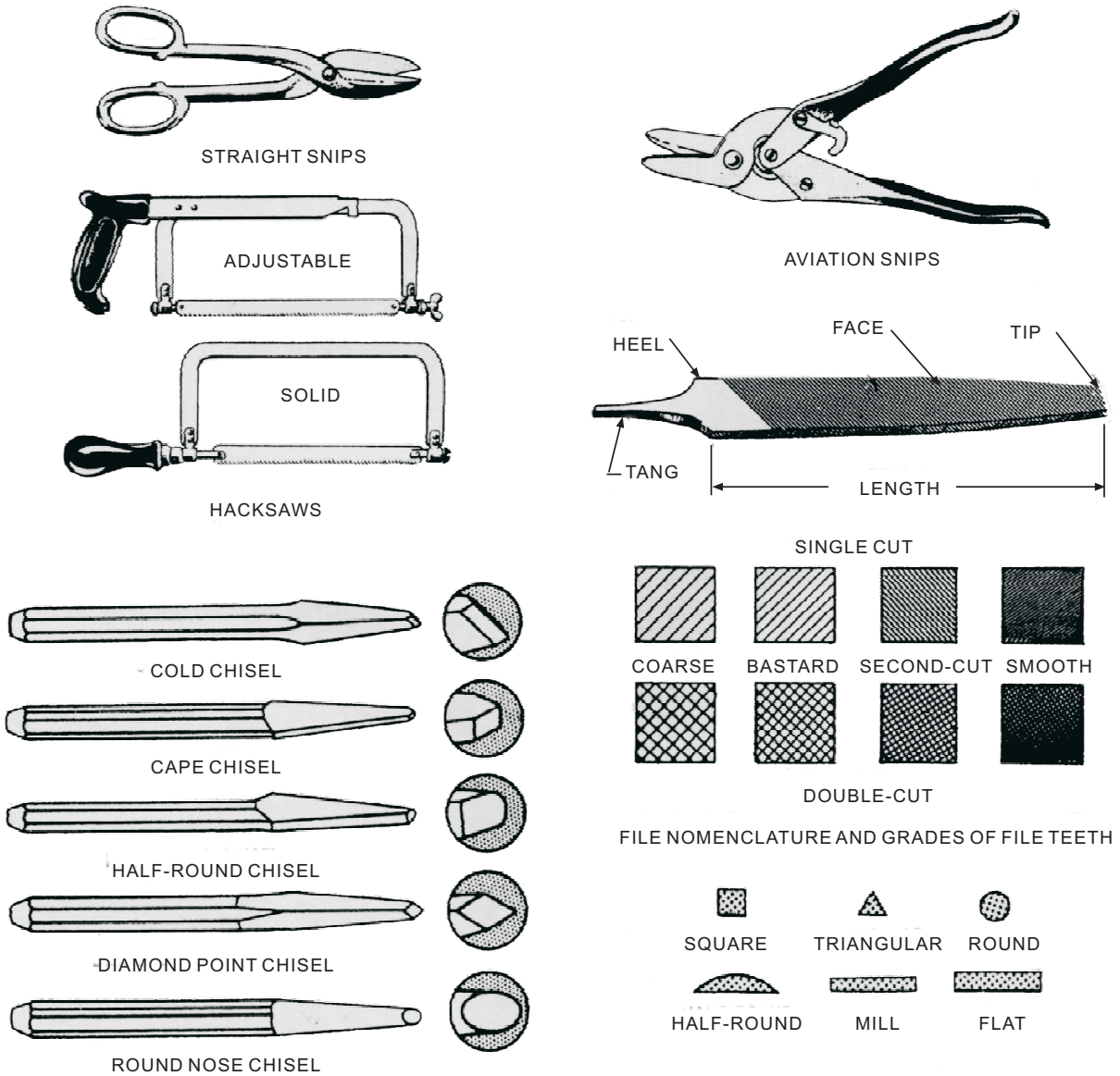

AMf04008

Figure 4-8.—Types of cutting tools.

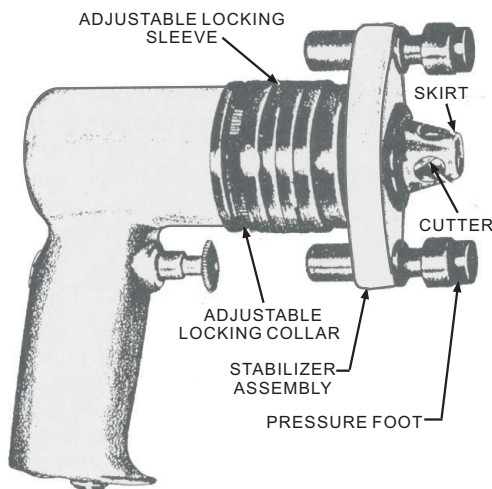

AMf04009

Figure 4-9.—Rivet-head shaver.

the surface being smoothed. With the tool turning at maximum rpm, you then press it in towards the surface, maintaining the 90-degree angle. The pressure feet will then be compressed until they bottom out. At this time, assuming the rivet-head shaver is adjusted correctly, the rivet head will be shaved aerodynamically smooth.

Pneumatic Riveters

Rivet guns vary in size and shape and have a variety of handles and grips. Nearly all riveting is done with pneumatic riveters. The pneumatic riveting guns operate on compressed air supplied from a compressor or storage tank. Normally, rivet guns are equipped with an air regulator on the handle to control the amount of air entering the gun.

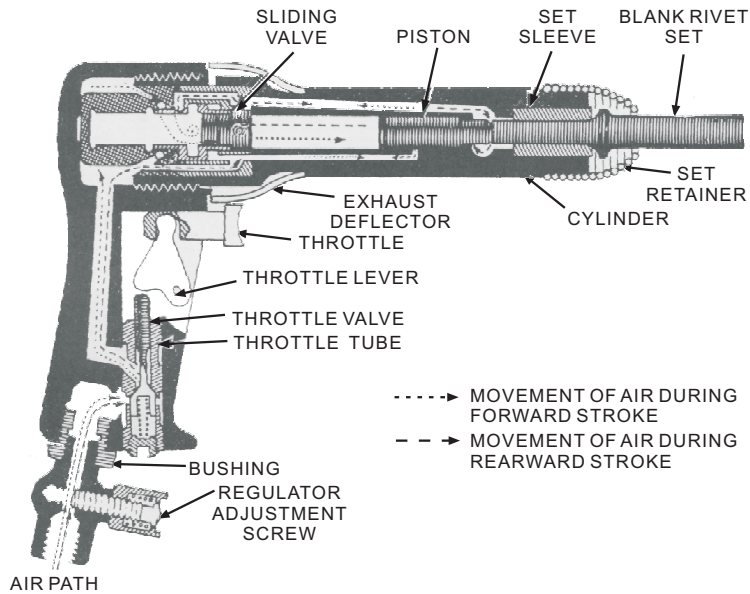

AMf04010

Figure 4-10.—Rivet gun internal airflow.

See figure 4-10. Regulated air entering the gun passes through the handle and throttle valve, which is controlled by the trigger, and into the cylinder in which the piston moves. Air pressure forces the piston down against the rivet set and exhausts itself through side ports.

The rivet set recoils, forcing the piston back. Then the cycle is repeated. Each time the piston strikes the rivet set, the force is transmitted to the rivet. Rivet sets come in various sizes to fit the various shaped rivet heads. Rivet set retainer springs must be used on all pneumatic rivet sets to prevent the set from being discharged from the gun when the trigger is pulled.

Several types of pneumatic riveters are in general use. They are the one-shot gun, slow-hitting gun, fast-hitting gun, corner riveter, and the squeeze riveter. See figure 4-11. The type of gun used depends on the particular job at hand, with each type having its advantages for certain types of work. One person can rivet small parts if the part is accessible for both bucking and driving. The greater part of riveted work, however, requires two people.

Rivet Guns

The size and the type of gun used for a particular job depend upon the size and alloy rivets being driven and the accessibility of the rivet. For driving medium-sized, heat-treated rivets that are in accessible places, the slow-hitting gun is preferred. For small, soft alloy rivets, the fast-hitting gun is preferable. There will be places where a conventional gun cannot be used. For this type of work, a corner gun is employed.

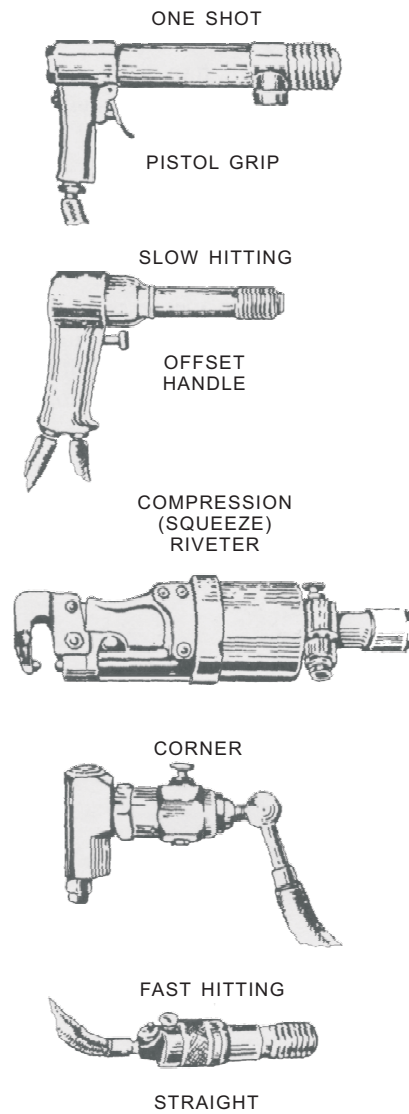

AMf04011

Figure 4-11.—Various types of rivet guns.

Larger rivets require greater air pressure. The approximate air pressures for four of the most common rivet sizes are given in table 4-1.

Table 4-1.—Approximate Air Pressure for Rivet Guns

Rivet Size	Air Pressure (PSI)
3/32	35
1/8	40
5/32	60

ONE-SHOT GUN.—The one-shot gun is designed to drive the rivet with just one blow. It is larger and heavier than other types and is generally used for heavy riveting. Each time the trigger is depressed, the gun strikes one blow. This gun is rather difficult to control on light-gauge metals. Under suitable conditions, it is the fastest method of riveting.

SLOW-HITTING GUN.—The slow-hitting gun has a speed of 2,500 bpm (blows per minute). As long as the trigger is held down, the rivet set continues to strike the rivet. This gun is widely used for driving medium-sized rivets. It is easier to control than the one-shot gun.

FAST-HITTING GUN.—The fast-hitting gun strikes the rivet with a number of relatively lightweight blows. It strikes between 2,500 and 5,000 bpm and is generally used with the softer rivets. Like the slow-hitting gun, it continues to strike the rivet head as long as the trigger is depressed.

CORNER RIVETER.—The corner riveter is so named because it can be used in corners and in close quarters where space is restricted. The main difference between this riveter and the other types is that the set is very short and can be used in confined spaces. See figure 4-11.

SQUEEZE RIVETER.—The squeeze riveter differs from the other riveters in that it forms the rivet head by means of squeezing or compressing instead of by distinct blows. Once it is adjusted for a particular type of work, it will form rivet heads of greater uniformity than the riveting guns. It is made both as a portable unit and as a stationary riveting machine. As a portable unit, it is larger than the riveting guns and can be used only for certain types of work that will fit between the jaws. The stationary, or fixed jaw contains the set and is placed against the rivet head in driving.

The rivet squeezer shown in figure 4-11 is the pneumatic type.

DRILLS

As is commonly known, drills are used to bore holes. In the following paragraphs, the correct use and some common errors in the usage of drills are presented. Additionally, a brief description of pneumatic and angle-drive drills is included.

Portable Drills

Before using a drill, turn on the power and check it for trueness and vibration. Do not use a drill bit that wobbles or is slightly bent. You can visually check a drill bits trueness by running the motor.

The most common error made by the inexperienced person is to hold a portable drill at an incorrect angle to the work. Make sure the drill is held at right angles to the work. When you are drilling in a horizontal position, you can see if the drill is too far to the right or left, but it is difficult to tell if the rear of the drill is too high or too low. Until you learn how to hold a drill at the correct angle, another person should sight the angle before starting the drill.

Another common mistake is to put too much pressure on the drill. Pushing or crowding a drill may break the drill point. It could cause the drill to plunge through the opposite side of the sheet and leave rough edges around the hole. It could also cause the drill to sideslip on the metal, causing hole elongation.

The drill should not be stopped immediately upon breaking through. It should continue to be inserted for approximately half its length while still running, and then withdrawn. This operation requires judgment and skill because it is very easy to ream the hole. If this is done properly, cleaner holes will result.

Pneumatic Drills

Pneumatic drills are available in various sizes and shapes. The drills are designed to provide a rotary shaft that is equipped with a chuck capable of holding a drill bit. Most drills are powered by a vane air motor; speed is adjustable by using the variable restrictor built into the motor body. Normal maintenance of the unit requires only a clean, dry air supply and periodic lubrication of the vane assembly. Lubrication can be accomplished by inducing a small amount of light oil

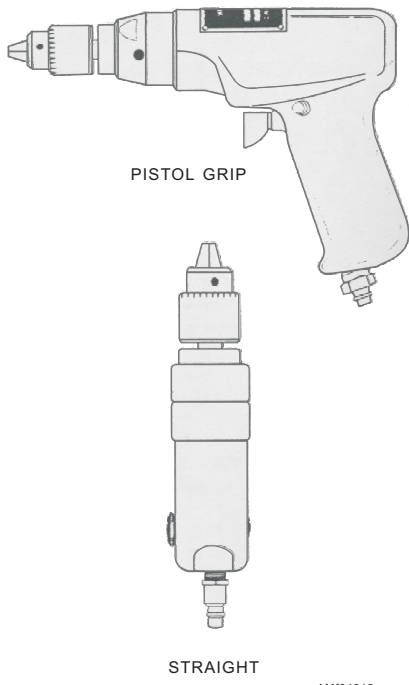

Figure 4-12.—Pneumatic drills.

into the air supply. The two most used types are the straight and the pistol grip. See figure 4-12.

Angle-Drive Drills

The angle-drive drills are attached to the drill motor by an adapter assembly or clamped into the existing drill chuck. They are available with a ridged or flexible drive shaft and come in several different head angles. See figure 4-13. These units are designed to be used as an extension of the drill motor in hard to reach areas. The drill motor should never be started unless you have positive control of the angle-drive unit. The flexible shaft is commonly referred to as a snake drill. The drill

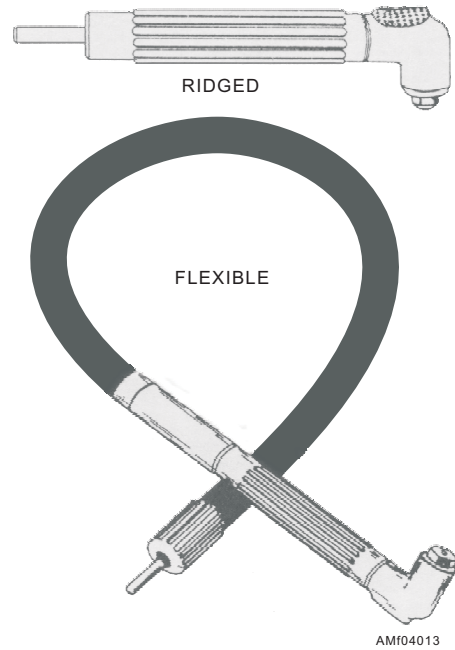

Figure 4-13.—Angle-drive drills.

chuck normally requires a wrench to tighten the jaws or it may require a special threaded drill bit.

SPECIAL TOOLS

Special tools are not normally part of an individual's toolbox. These tools are normally maintained in a central tool room and signed out when needed.

Dimple Countersinking Tools

Dimple countersinking is accomplished by using male and female dies. The female die, shown in figure 4-14, contains a spring-loaded ram that flattens the bottom of the dimple as it is formed. This prevents

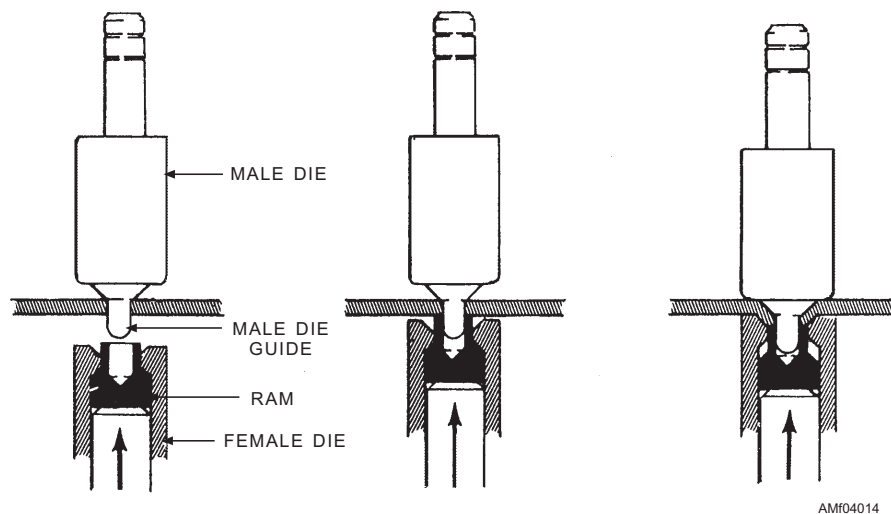

Figure 4-14.—Dimple countersinking.

cracks from forming around the dimple. The forming of a dimple is a combined bending and stretching operation. A circular bend is formed around the hole. As in any bending operation, the tension force at the upper side of the bend (break) creates the radius at the junction of the two surfaces—the top side of the sheet and the downward bent inner wall of the dimple depression. The stretch occurs around the hole as it is displaced from its original position and relocated at the bottom of the dimple. The female die must have a slightly larger cone diameter than the corresponding dimension of the male die. This allows for material thickness and relieves the bending load at the break in order to avoid circumferential cracks around the boundaries of the dimple. As a further safeguard, a slight radius is made on the female die at the junction of the top face with the dimple depression.

Dimpling dies are made to correspond to any size and degree of countersunk rivet head available. The dies are numbered, and the correct combination of dies to use is indicated in charts specified by the manufacturer. Both male and female dies are machined accurately and have highly polished surfaces. When you dimple a hole, place the material on the female die and insert the male die in the hole to be dimpled. The dies are generally brought together, forming the dimple by a mechanical or pneumatic force.

As newer aluminum alloys were developed to increase shear and tensile strength, they became more difficult to form, since these alloys are harder and more brittle. These aluminum alloys are subject to cracking when formed or dimpled cold. For this reason, it is necessary to use a hot dimpling process. The application of hot dimpling to the more brittle materials helps reduce cracking. The heat is applied to the material by the dies, which are maintained at a specific temperature by electrical heaters. The heat is transferred to the material to be dimpled only momentarily, and none of the heat-treat characteristics of the material are lost.

There are several models of dimpling machines used in the Navy, from the bulky floor models to portable equipment. One of the most popular portable types is shown in figure 4-15. Basically, it has three units: the dimpling control unit, the dimpling squeezer, and the thermo dimple gun.

The dimpling control unit is a small compact unit designed to regulate dimple die temperatures, prepressure, dwell time, and final forming pressure.

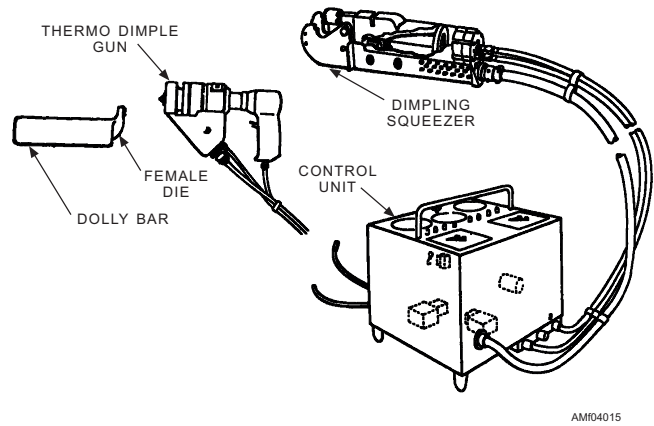

Figure 4-15.—Hot dimpling kit.

This same unit is used with both the hot dimpling squeezer and the thermo dimple gun.

The hot dimpling squeezer is designed for use where stationary squeezer operation is impractical or impossible. It is capable of working all material gauges up to and including 0.091 of an inch. The squeezer is designed to dimple in areas that are inaccessible to other types of equipment. Electrical heaters independently warm male and female dies. The heaters produce a short heat-up and recovery time. The male die is adjustable to provide the maximum squeeze on all gauges of material. The unit also has a cooling feature.

The thermo dimple gun is used to dimple in the center of panels and in those areas otherwise inaccessible to stationary dimpling equipment. When it is being used on the aircraft, the thermo dimple gun drives the dimple from the exterior while the female die and dolly bar are used on the inside. The thermo dimple gun is air-cooled. This eliminates the need for cumbersome heat-resistant gloves. This tool is small, compact, well balanced, and easy to handle.

Before adjusting the control unit for dimpling, you should refer to the equipment manufacturer's dwell time chart. When you set up any dimpling equipment, follow the step-by-step procedure outlined in the operating and maintenance manual supplied with the equipment. Since equipment types vary, it is impractical to specify a standard procedure; however, there are four general requirements of a dimple, and by examining each, it is possible to denote improper setting up of equipment.

1. Sharpness of definition. It is possible to get a dimple with a sharp break from the surface into the dimple. Two things control the sharpness of the break: the amount of pressure and the material thickness.

2. Condition of dimple. The dimple must be checked for cracks or flaws that might be caused by damaged or dirty dies, or by improper heating.

3. Warpage of material. The amount of warpage may be held to a minimum if the correct pressure setting is held. When dimpling a strip with too much pressure, the strip tends to form a convex shape, as shown in figure 4-16. When insufficient pressure is used, it tends to form a concave shape. Warpage of material can be checked by using a straightedge.

4. General appearance. The dimple should be checked with the fastener that is to be used, making sure it meets the flushness requirement. This is important because the wrong type or size of die can sometimes be used by mistake.

Squaring Shears

Squaring shears are used for cutting and squaring sheet metal. See figure 4-17. They may be foot operated or power operated. Squaring shears consist of a stationary blade attached to a bed and a movable blade attached to a crosshead. To make a cut, place the work in the desired position on the bed of the machine. Then use a downward stroke to move the blade.

Foot-powered squaring shears are equipped with a spring that raises the blade when foot pressure is removed from the treadle. A scale graduated in fractions of an inch is scribed on the bed. Two side guides, consisting of thick steel bars, are fixed to the bed, one on the left and one on the right. Each is placed so that its inboard edge creates a right angle with the cutting edge of the bed. These bars are used to align the metal when square corners are desired. When cuts other than right angles are to be made across the width of a piece of metal, the beginning and ending points of the cut must be determined and marked in advance. Then the work is carefully placed into position on the bed

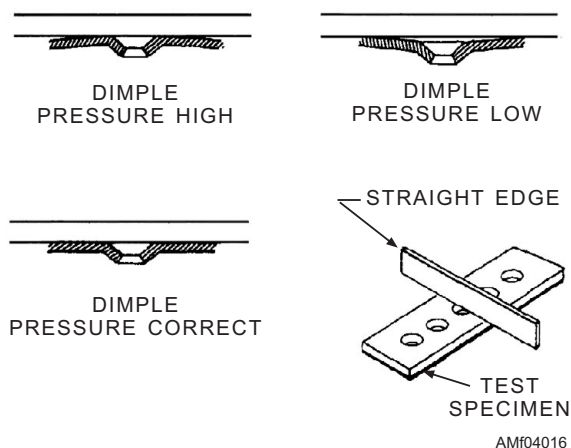

Figure 4-16.—Checking dimple equipment air pressure.

with the beginning and ending marks on the cutting edge of the bed.

A hold-down mechanism is built into the front of the movable cutting edge in the crosshead. Its purpose is to clamp the work firmly in place while the cut is being made. This action is quickly and easily accomplished. The handle is rotated toward the operator and the hold-down lowers into place. A firm downward pressure on the handle at this time should rotate the mechanism over center on its eccentric cam and lock the hold-down in place. You should reverse the action to release the work.

Three distinctly different operations—cutting to a line, squaring, and multiple cutting to a specific size—may be accomplished on the squaring shears. When you are cutting to a line, place the beginning and ending marks on the cutting edge and make the cut. Squaring requires a sequence of several steps. First, square one end of the sheet with one side. Then square the remaining edges, holding one squared end of the sheet against the side guide and making the cut, one edge at a time, until all edges have been squared.

When several pieces are to be cut to the same dimensions, you should use the adjustable stop gauge. This stop is located behind the bed cutting edges of the blade and bed. The supporting rods for the stop gauge are graduated in inches and fractions of an inch. The gauge bar is rigged so that it may be set at any point on the rods. With the gauge set at the desired distance from the cutting blade, push each piece to be cut against the stop. This procedure will allow you to cut all pieces to the same dimensions without measuring and marking each one separately.

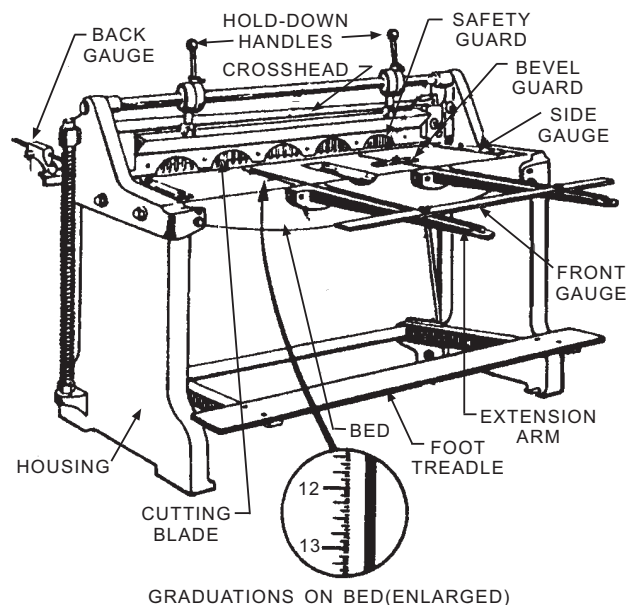

Figure 4-17.—Squaring shears.

NOTE: After you cut the first piece in a series, measure it to make sure that the stop is accurately set.

Throatless Shears

Throatless shears are constructed so sheets of any length may be cut and the metal turned in any direction during the cutting operation. See figure 4-18. Irregular lines can be followed or notches made without distorting the metal. Throatless shears are an adaptation of heavy handshears or snips in which the handles are removed, one blade secured to a base, and a long lever attached to the tip of the movable blade. The heavy-duty throatless shears are capable of cutting stainless steel up to 0.083 of an inch thick.

Hand Bench Shears

The hand bench shears operate similar to a paper cutter. They have one fixed blade and a movable blade, hinged at the back. They are similar to the throatless shears except the blades are straight and used only for straight cutting. Some bench shears have a punching attachment on the end of the frame opposite the shearing blades. This attachment is used to punch holes in metal sheets.

To cut stock that is narrower in width than the length of the blades, the lever of the shears can be pulled all the way down. When you are cutting larger pieces, a series of short bites should be made.

NOTE: Complete closing of the blade tends to tear the sheet at the end of each cut.

Unishear

Unishear is a trade name for a type of portable power shears. It is used for cutting curves and notches as well as straight-line cutting.

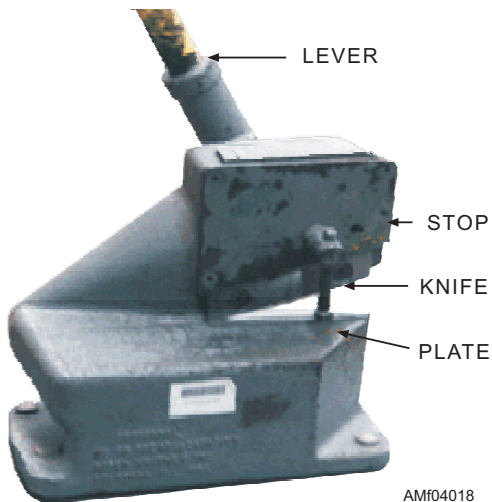

Figure 4-18.—Throatless shears.

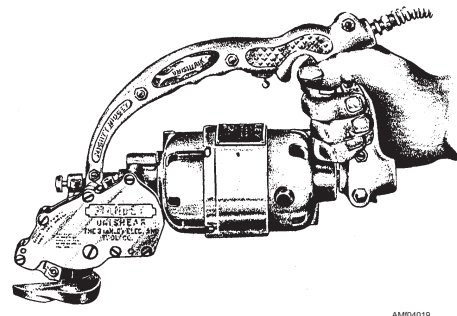

Figure 4-19.—18-gauge Unishear.

This tool might be called power-operated, combination snips. It has two short blades. The lower blade is held in a fixed position. The upper blade moves up and down in short strokes at a high rate of speed. Its chewing motion is the basis for the widely used nickname of this power tool—"nibblers." Figure 4-19 shows an 18-gauge Unishear.

The cutting blades are easily removed for sharpening and replacement. The machine will cut as fast as it can be fed, up to 15 feet per minute. This is a ruggedly constructed machine; but for satisfactory performance, you must give it the best of care. It should be kept cleaned and oiled at all times.

Hand-Operated Turret Punch

A hand-operated turret punch is shown in figure 4-20. Twelve mated punches and dies are mounted in a rotating turret. Stamped on the front of each die block is the size of hole it will punch, as well as the thickness of the material it will accommodate. When you are punching stainless steel or other alloys, you must remember that these capacities are for mild steel.



Figure 4-20.—Hand-operated turret punch.

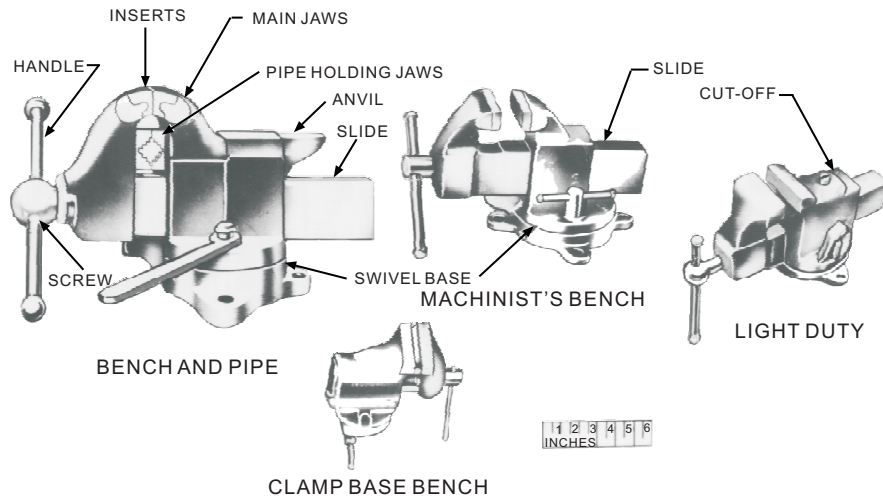

AM104021

Figure 4-21.—Common types of bench vices.

The operation of the turret punch is simple. First, release the locking handle on the side of the punch frame, rotate the turret until the desired punch set is lined up with the actuating mechanism (ram), and then lock the turret into position. Then punch the hole by pulling the operating lever toward you. This actuates the ram and punch.

Sheet Metal Bending Equipment

There are several types of sheet metal bending equipment that are used to form or bend sheet metal.

WISE.—Vises are used for holding sheet metal when it is being shaped or riveted. Figure 4-21 shows the most common bench vices that are used throughout the Navy. The machinist's bench vise is the one most generally used for forming sheet metal. The machinist's bench vise is a large steel vise with rough jaws that prevent the work from slipping. It has a swivel base, allowing the user to position the vise in a better working position. Machinist's vices are usually bolted to a workbench or table.

CORNICE BRAKE.—The cornice brake is designed to bend large sheets of metal. See figure 4-22.

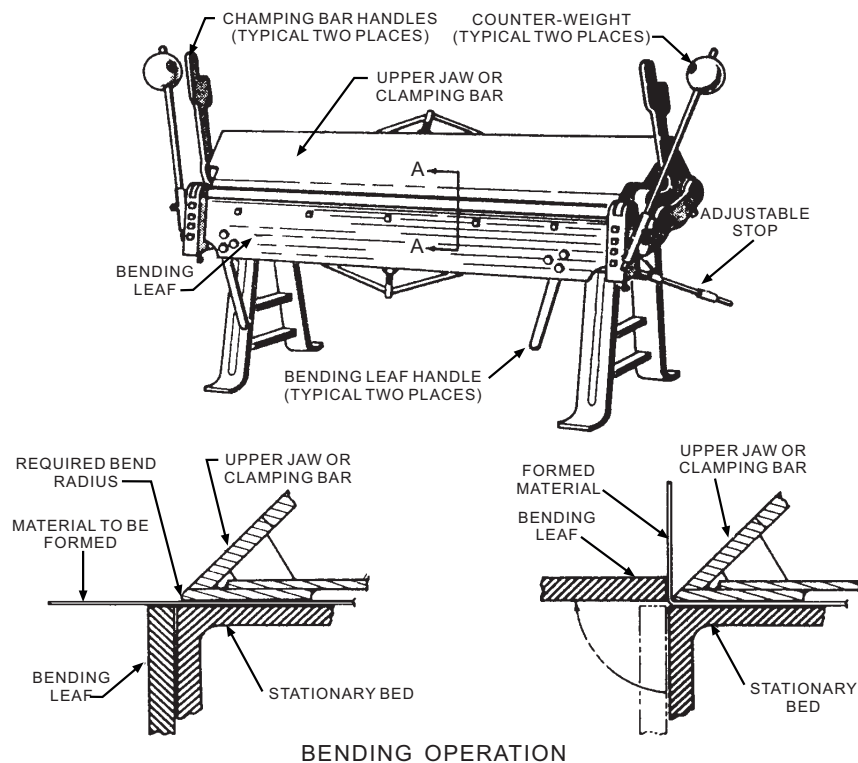

AM104022

Figure 4-22.—Cornice brake and operation.

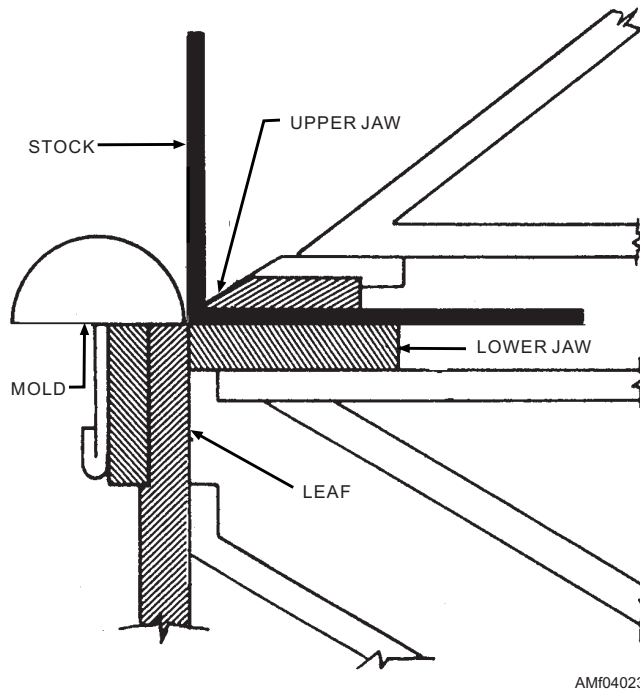

AMf04023

Figure 4-23.—Cornice brake with mold and stock.

It can be adjusted to handle a variety of metal thicknesses and to bend metal to a variety of radii.

The brake is equipped with a stop gauge, which consists of a rod, a yoke, and a setscrew. The stop gauge limits the travel of the bending leaf. This feature is used to make a number of pieces with the same angle of bend.

The standard cornice brake is extremely useful for making single hems, double hems, lock seams, and various other shapes, some of which require the use of molds. The molds are fastened to the bending leaf of the brake by friction clamps. Figure 4-23 shows sheet

metal that is ready to be formed over a mold attached to a cornice brake.

BAR FOLDER.—The bar folder, shown in figure 4-24, is designed for use in making bends or folds along edges of sheets of metal. This machine is best suited for folding small hems, flanges, seams, and edges to be wired. Most bar folders have a capacity for metal up to 22 gauge in thickness and 42 inches in length. Before using the bar folder, you must make several adjustments, including adjustments for thickness of material, width of fold, sharpness of fold, and angle of fold.

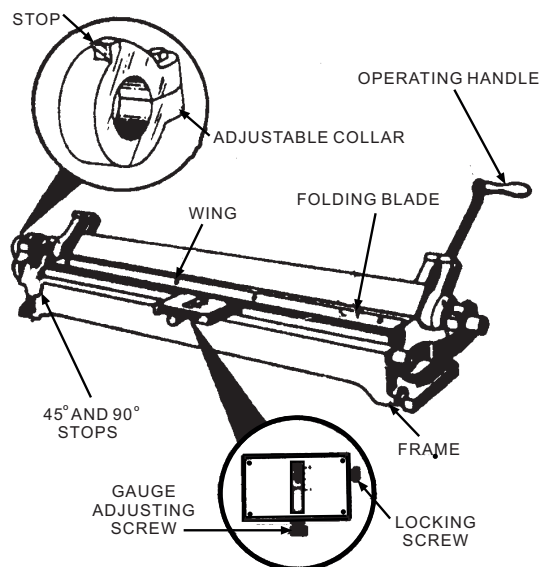

AMf04024

Figure 4-24.—Bar folder.

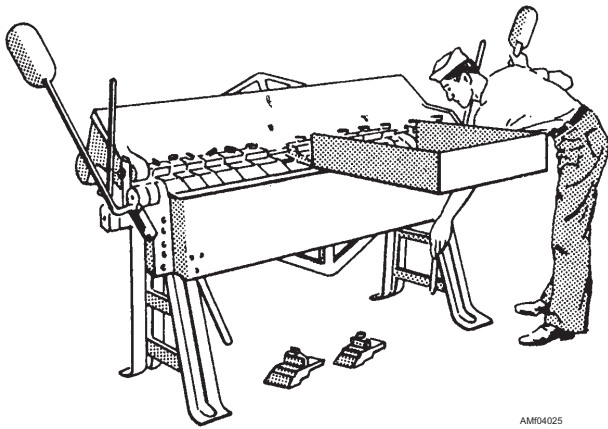

Figure 4-25.—Box and pan brake being used to form box.

BOX AND PAN BRAKE.—The box and pan brake, shown in figure 4-25, is often called the “finger brake” because it does not have a solid upper jaw as does the cornice brake. Instead, it is equipped with a series of steel fingers of varying widths. The finger brake can be used to do everything that the cornice brake can do and several things that the cornice brake cannot do.

The finger brake is used to form boxes, pans, and other similarly shaped objects. If these shapes were formed on a cornice brake, you would have to straighten part of the bend on one side of the box in order to make the last bend. With a finger brake, you simply remove the fingers that are in the way and use only the fingers required to make the bend.

The fingers are secured to the upper leaf by thumbscrews, as shown in figure 4-26. All the fingers that are not removed for an operation must be securely seated and firmly tightened before the brake is used.

To keep brakes in good condition, you should keep the working parts well oiled and be sure the jaws are free of rust and dirt. When you operate brakes, be careful to avoid doing anything that would spring the parts, force them out of alignment, or otherwise

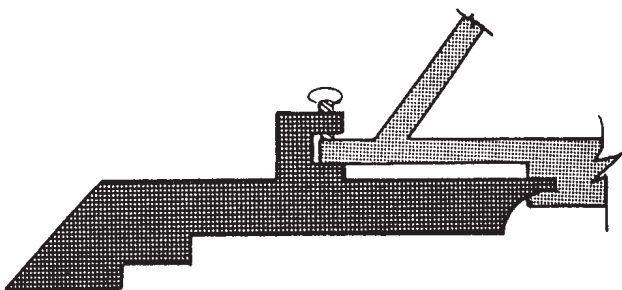

Figure 4-26.—Finger secured in box and pan brake.

damage them. Never use brakes for bending metal that is beyond the machine's capacity with respect to thickness, shape, or type. Never try to bend rod, wire, strap iron, or spring steel sheets in a brake. If it is necessary to hammer the work, take it out of the brake first.

FORMING MACHINES.—A sheet metal object made on a brake will have corners (bends) and sides (flanges). On a forming machine, it is possible to make an object without sides. For example, you can make a circular object such as a funnel. The forming machines used in the Navy are usually located at aircraft intermediate maintenance departments (AIMDs). The two most common machines are the slip roll and the rotary.

Slip-Roll Forming Machine.—Sheet metal can be formed into curved shapes over a pipe or a mandrel, but the slip-roll forming machine is easier to use and produces more accurate bends. Rolling machines are available in various sizes and capacities. Some are hand operated, like the one shown in figure 4-27, and others are power operated.

The machine shown in the illustration has two rolls in the front and one roll at the rear. You can adjust screws on each end of the machine to control the distance between the front rolls. By varying the adjustments, the machine can be used to form cylinders, cones, and other curved shapes. The front rolls grip the metal and pull it into the machine; therefore, the adjustment of distance between the two front rolls is made on the basis of the thickness of the sheet being worked.

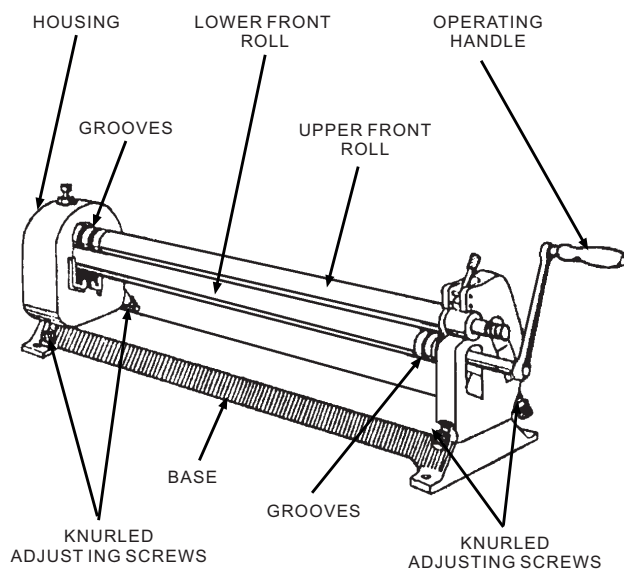

Figure 4-27.—Slip-roll forming machine.

Rotary Machine.—The rotary machine, shown in figure 4-28, is used on cylindrical and flat sheet metal to shape the edge or to form a bead along the edge. Various shaped rolls can be installed on the rotary machine to perform these operations.

- Q4-1. A soft-faced hammer is known by what name?
- Q4-2. When rivets are too long for repair, you can size them to the correct length with what tool?
- Q4-3. What must you use to form a bucktail on a rivet?
- Q4-4. Locally manufactured bucking bars are normally made from what type of steel?
- Q4-5. To transfer hole locations from the airframe or skin to a patch, you should use what tool?
- Q4-6. What is the color of a 1/8-inch Cleco fastener?
- Q4-7. What is the difference between snips and shears?
- Q4-8. What are the five types of pneumatic riveters?
- Q4-9. What rivet gun is generally used for heavy hitting, and under suitable conditions, is the fastest method of riveting?
- Q4-10. What will happen if you apply too much pressure to the drill?
- Q4-11. Most pneumatic drills are powered by what type of motor?
- Q4-12. A flexible shaft drill is also known by what other name?

- Q4-13. The combination of bending and stretching of metal, using male and female dies, forms what type of countersink?
- Q4-14. Why is it necessary to use a hot dimpling process for aluminum alloys?
- Q4-15. Portable power-operated snips are more commonly referred to by what name?
- Q4-16. What sheet metal equipment would you use to fabricate a wire edge?
- Q4-17. What brake has removable steel fingers of varying widths?

SHEET METAL FABRICATION

LEARNING OBJECTIVE: Recognize the terms associated with the fabrication of sheet metal parts. Identify the various procedures used in the fabrication of sheet metal parts.

To effectively construct and repair parts of an airframe, you must be able to lay out, cut, and form metal. The layout of bend lines must include the allowance for the amount of material used to make the bend in the proper location. The proper fit of the finished part can be ensured if the layout, cuts, and bends are carefully considered before the actual fabrication is started. The procedures and equipment discussed in this chapter are designed to provide accurate and dependable results.

The development of a layout on sheet metal is basically the same as the development of blueprints and drawings. For a better understanding of these procedures, you should refer to *Blueprint Reading and Sketching*, NAVEDTRA 14040.

LAYOUT PROCEDURES

When you are laying out metal, there are certain precautions that should be observed. In the following paragraphs, some of the more important precautions are discussed. For information on the use of layout tools, you should refer to *Use and Care of Hand Tools and Measuring Tools*, NAVEDTRA 14256.

You should take every precaution to avoid marring aluminum-alloy and steel sheets. To protect the under surface of the material from any possible damage, you should place a piece of heavy paper, felt, or plywood between the material and the working surface. When you are working with a large sheet of material, it is important to avoid bending it. It is a good idea to have someone help you place it on the work surface.

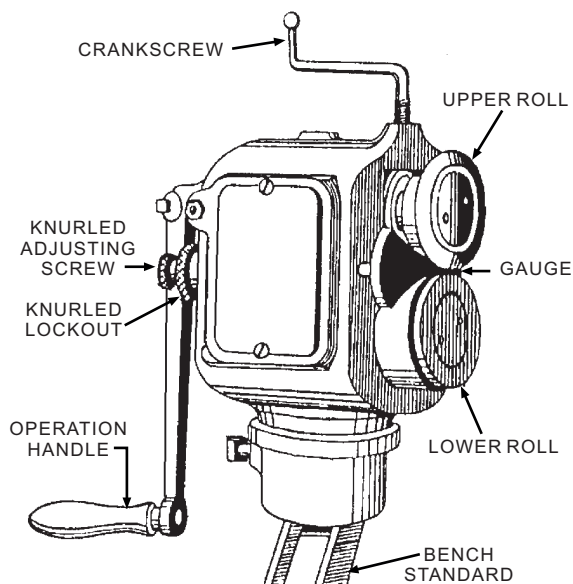

Figure 4-28.—Rotary machine.

A layout fluid should be applied to the surface of the metal so that the pattern will stand out clearly. Any one of several approved fluids may be used. Bluing fluid, a blue dye dissolved in alcohol, is the most commonly used layout fluid. Since it does not protect metal against corrosion or serve as a paint binder, bluing fluid should be removed after use. Either ordinary paint thinner or alcohol may be used to remove it.

To begin the layout, you should ensure that one edge of the metal is straight. All measurements can then be based on the straight edge of the sheet. Lines at a known angle or parallel to the straight edge can be made by marking points from a combination square held firmly against the straight edge.

If it is impossible to obtain a straight edge on a sheet to start a layout or if the distance from the edge is too great, a reference line may be used. The reference line may be made by connecting any two points with a straight line. Perpendiculars may be erected to the reference line by using a compass or dividers. Once the perpendicular is accurately established, it may be used as a basis for almost any layout.

A scribe must never be used for drawing lines on aluminum or magnesium except to indicate where the metal is to be cut or drilled. All other lines should be drawn with a soft-lead pencil. The pencil mark should be removed from aluminum and magnesium to prevent an electrolytic action that will eventually cause corrosion. It can be removed with isopropyl alcohol or MEK. If you fold a piece of metal along a sharp line made with a scribe, the scribed line will weaken the metal and possibly cause it to crack along the bend. If it does not crack at the time of bending, it is very susceptible to cracking at a later time when failure of the part could be dangerous.

Bend Allowance

When you are bending metal to exact dimensions, the amount of material needed to form the bend must be known. The term for the amount of material that is actually used in making the bend is *bend allowance*.

Bending compresses the metal on the inside of the bend and stretches the metal on the outside of the bend. Approximately halfway between these two extremes lies a space that neither shrinks nor stretches. This space is known as the neutral line or neutral axis. Figure 4-29 shows the neutral axis of a bend. It is along this neutral axis that bend allowance is computed.

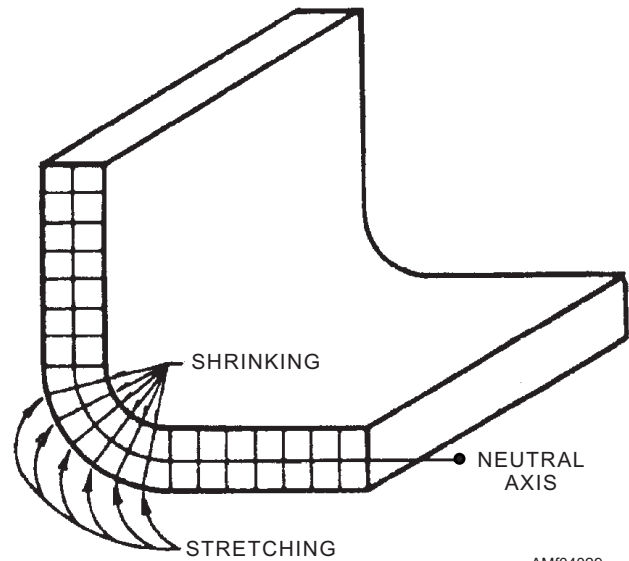

Figure 4-29.—Neutral axis.

BEND ALLOWANCE TERMS

You should be familiar with the following terms related to a bending job. Figure 4-30 shows the meaning of some of these terms.

- *Bend allowance*. The amount of material consumed in making a bend.
- *Closed angle*. An angle that is less than 90 degrees when measured between legs. When the

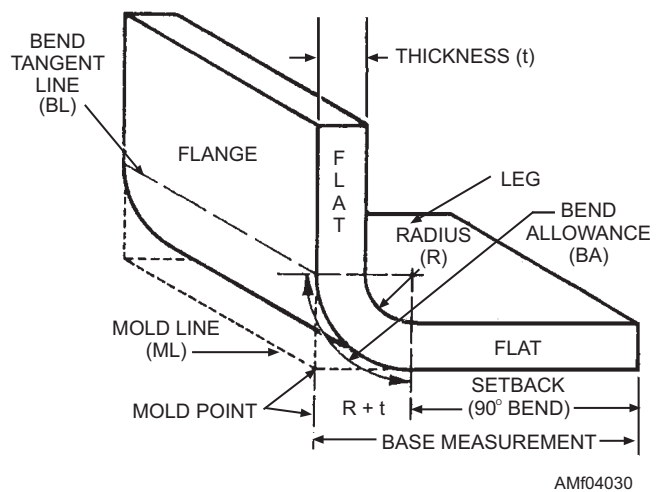
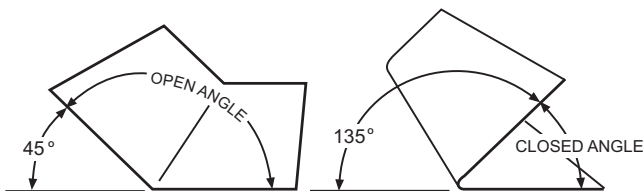

Figure 4-30.—Bend allowance terms.

closed angle is 45 degrees, the amount of bend is 180 minus 45 or 135 degrees. See figure 4-31.

- *Open angle.* An angle that is more than 90 degrees when measured between legs or less than 90 degrees when the amount of bend is measured.
- *Flange.* The shorter part of a formed angle—the opposite of leg. If each side of the angle is the same length, then each is known as a leg.
- *Flat.* The flat portion, or flat, of a part is that portion not included in the bend. It is equal to the base measurement minus the setback.
- *K number.* A K number is one of 179 numbers on the K chart that corresponds to one of the angles between 0 and 180 degrees to which metal can be bent. When metal is to be bent to any angle other than 90 degrees (K number of 1.0), the corresponding K number is selected from the chart and multiplied by the sum of the radius and the thickness of the metal. The product is the amount of setback for the bend.
- *Leg.* The longer part of a formed angle.
- *Bend line.* The bend line (also called the brake or sight line) is the layout line on the metal being formed that is set even with the nose of the brake, and it serves as a guide in bending the work. Before forming a bend, the metalsmith must decide which end of the material can be most conveniently inserted in the brake. The bend line is then measured and marked with a soft-lead pencil from the bend tangent line closest to the end that is to be placed under the brake. This measurement should be equal to the radius of the bend. The metal is then inserted in the brake so that the nose of the brake will fall directly over the bend line. See figure 4-32.
- *Bend tangent line.* The line at which the metal starts to bend and the line at which the metal stops curving. All the space between the bend tangent lines is the bend allowance.



AMF04031

Figure 4-31.—Open and closed angles.

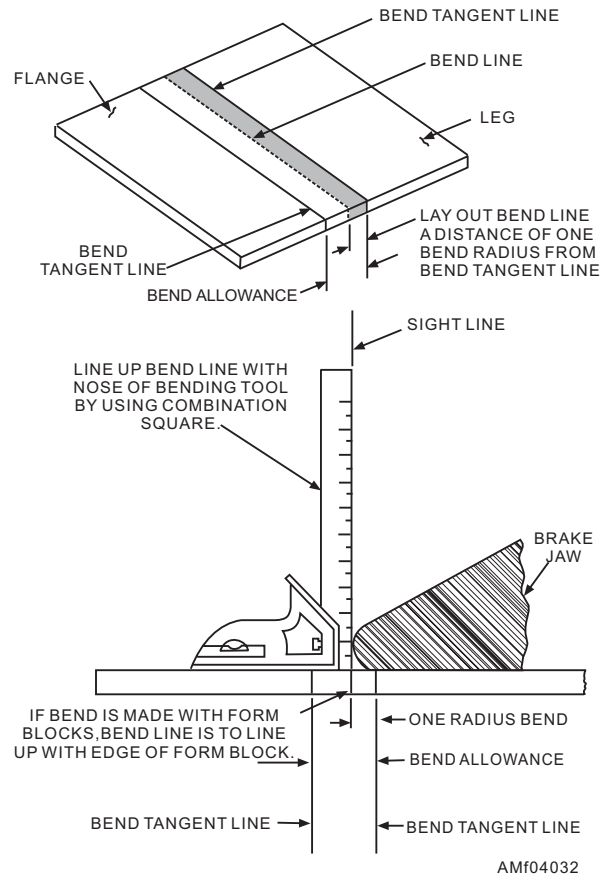

Figure 4-32.—Locating bend lines in a brake.

- *Mold line.* The line formed by extending the outside surfaces of the leg and the flange. (An imaginary point from which real base measurements are provided on drawings.)
- *Base measurement.* The base measurement is the outside dimension of a formed part. Base measurement will be given on the drawing or blueprint, or it may be obtained from the original part.
- *Radius.* The radius (R) of the bend is always to the inside of the metal being formed unless otherwise stated. The minimum allowable radius for bending a given type and thickness of material should always be determined before you proceed with any bend allowance calculations.
- *Setback.* The setback (SB) is the distance from the bend tangent line to the mold point. In a 90-degree bend, $SB = R + T$ (radius of the bend plus thickness of the metal). The setback dimension must be determined prior to making the bend because setback is used in determining the location of the beginning bend tangent line.

BEND ALLOWANCE FORMULA

By experimentation with actual bends in metals, aircraft engineers have found that accurate bending results could be obtained by using the following formula for any degree of bend from 1 to 180:

$$(0.0173 \times R + 0.0078 \times T) \times N = BA$$

Where

R = the desired bend radius,

T = the thickness of the material, and

N = the number of degrees of bend.

Refer to the NA 01-1A-1 for the appropriate bend allowance tables.

CUTTING SHEET METAL

Once a project has been laid out on the metal, the next step is to cut it to shape. The type of cutting equipment to be used depends primarily upon the type and thickness of the material. Another consideration is the size and number of pieces to be cut. A few relatively thin pieces of comparatively soft metal may be cut faster with hand-trimming methods. But for harder

metals, faster output, and more professional results, machines designed for metal-cutting purposes are used.

Machines used to cut sheet metal may be divided into two groups—manually operated and power operated. Each cutting machine has a definite cutting capacity that should never be exceeded. A few of the more common types that may be available to you have been described in the previous sections.

BENDING SHEET METAL

Straight-line bends and folds in sheet metal are ordinarily made on the cornice brake and bar folder; however, a considerable amount of bending is also completed by hand-forming methods. Hand forming may be accomplished by using stakes, blocks of wood, angle iron, a vise, or the edge of a bench.

Bending Over Stakes

Stakes are used to back up sheet metal to form many different curves, angles, and seams. Stakes are available in a wide variety of shapes, some of which are shown in figure 4-33. The stakes are held securely in a stake holder or stake plate, which is anchored in a

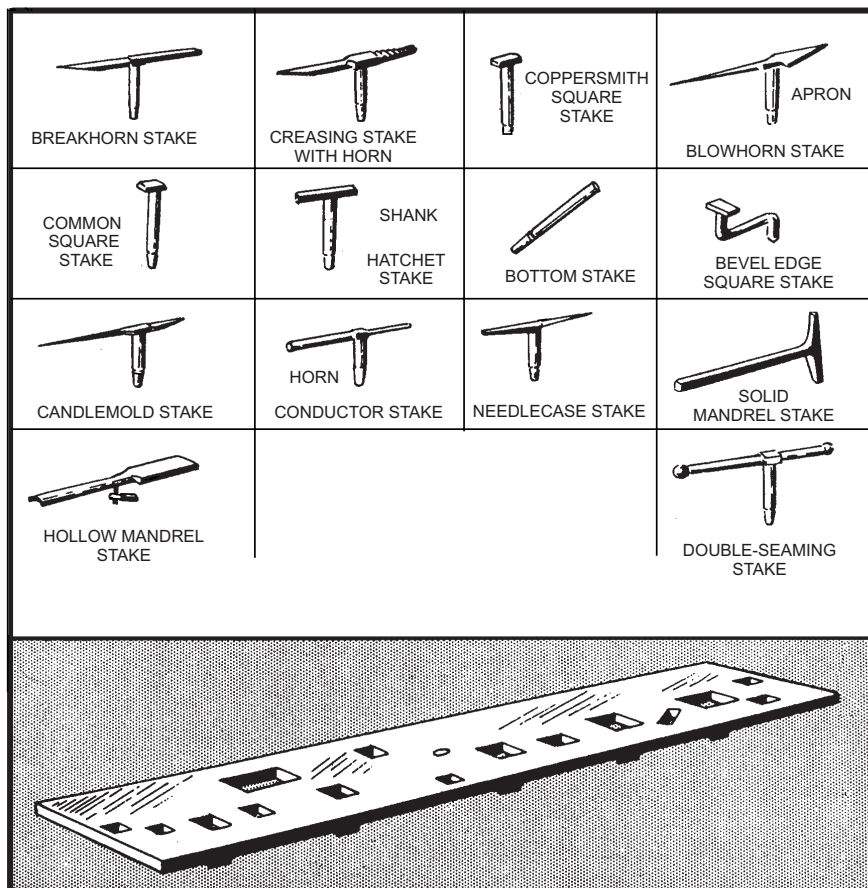

AM104033

Figure 4-33.—Stakes and stake plates.

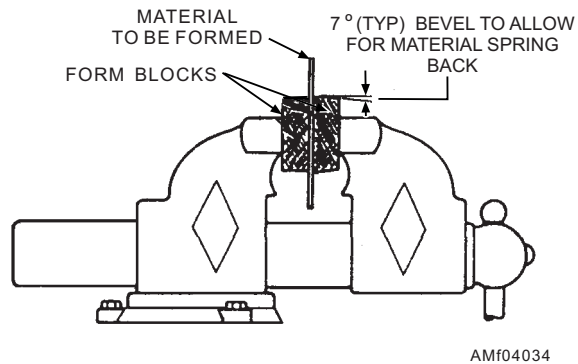

Figure 4-34.—Preparation for straight bend by hand.

workbench. The stake holder contains a variety of holes to fit a number of different types of shanks. Although stakes are by no means delicate, they must be handled with reasonable care. They should not be used as backing when you are chiseling holes or notches in sheet metal.

Bending in a Vise

Straight-line bends of comparatively short sections can be made by hand with the aid of wooden or metal bending blocks. After the part has been laid out and cut to size, you should clamp it along the bend line between two form blocks, which are held in a vise. The form blocks usually have one edge rounded to give the desired bend radius. See figure 4-34. By tapping lightly with a rubber, plastic, or rawhide mallet, bend the metal protruding beyond the bending block to the desired angle.

You should gradually make the bend even. Start tapping at one end and work back and forth along the edge. Continue this process until the protruding metal is

bent to the desired angle. If a large amount of metal extends beyond the bending blocks, you should maintain enough hand pressure against the protruding sheet to prevent the metal from bouncing. Remove any irregularity in the flange by holding a straight block of hardwood edgewise against the bend and striking it with heavy blows of a hammer or mallet. If the amount of metal protruding beyond the bending blocks is small, make the entire bend by using the hardwood block and a hammer.

Curved flanged parts have mold lines that are either concave or convex. The concave flange is formed by stretching, while the convex flange is formed by shrinking. Such parts are shaped with the aid of hardwood or metal form blocks. These blocks are made in pairs and specifically for the shape of the part being formed. Each pair conforms to the actual dimension and contour of the finished article.

You should cut the material to be formed to size, allowing about one-quarter inch of excess material for trim. File and smooth the edges of the material to remove all nicks caused by the cutting tools. This reduces the possibility of the material cracking at the edges during the forming operation. Place the material between the form blocks and clamp it in a vise so that the material will not move or shift. Clamp the work as closely as possible to the particular area being formed to prevent strain on the form block and to keep the material from slipping.

Concave surfaces are formed by stretching the material over a form block. See figure 4-35. You should use a plastic or rawhide mallet with a smooth, slightly

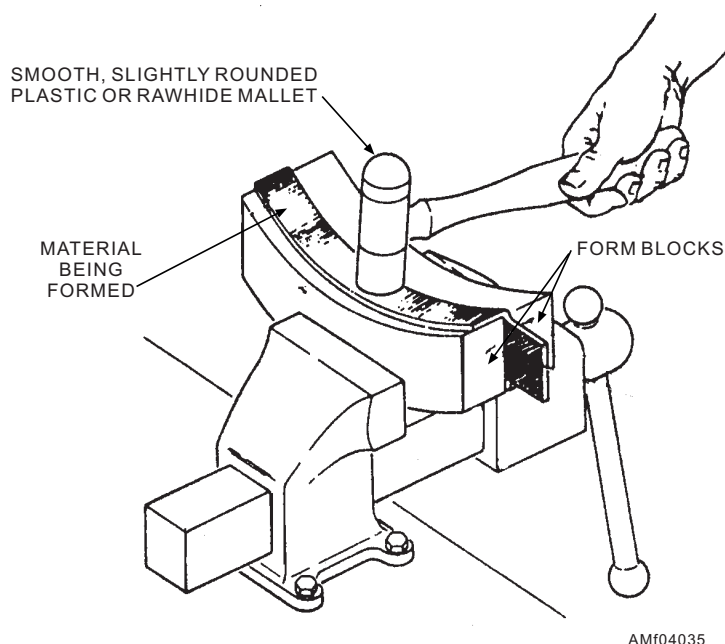
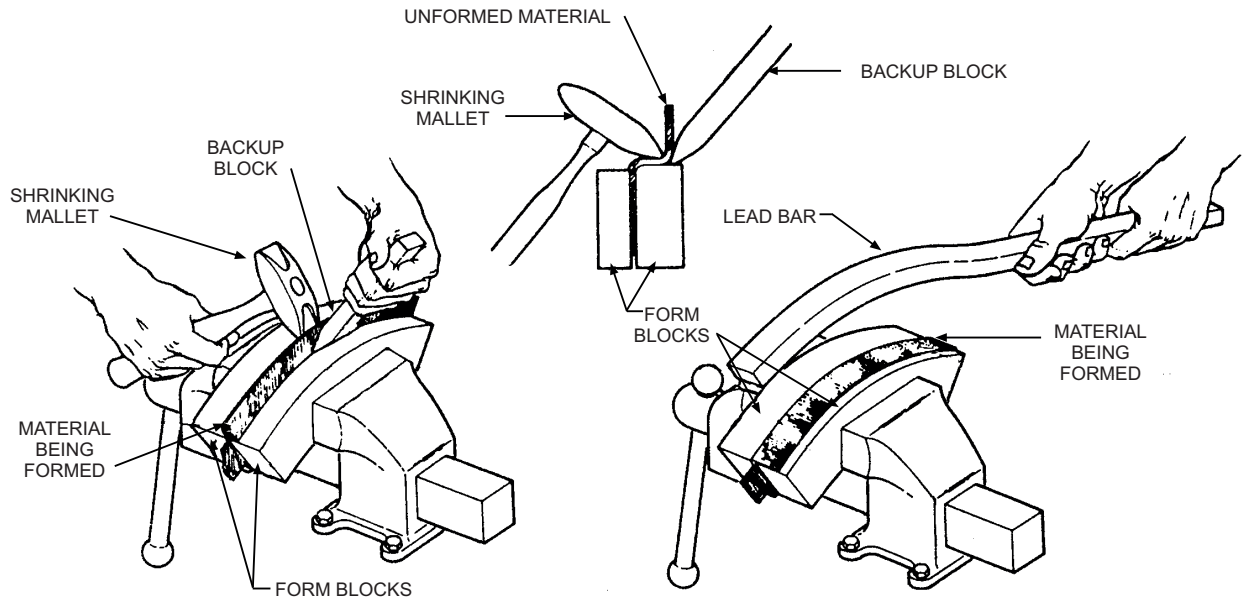

Figure 4-35.—Forming concave hand bend.



AMf04036

Figure 4-36.—Forming convex hand bends.

rounded face to start hammering at the extreme ends of the part, and then continue toward the center of the bend. This procedure permits some of the material at the ends of the part to be worked into the center of the curve where it will be needed. Continue hammering until the metal is gradually worked down over the entire flange and flush with the form block. After the flange is formed, trim off the excess material and check the part for accuracy.

Convex surfaces are formed by shrinking the material over a form block. See figure 4-36. You should use a wooden or plastic shrinking mallet and a backup or wedge block to start hammering at the center of the curve, and then work toward both ends. Hammer the flange down over the form by striking the metal with glancing blows at an angle of approximately 45 degrees. You should use a motion that will tend to pull the part away from the radius of the form block. The wedge block is used to keep the edge of the flange as nearly perpendicular to the form block as possible. The wedge block also lessens the possibility of buckling, splitting, or cracking the metal.

Another method of hand forming convex flanges is to use a lead bar or strap. The material, which is secured in the form block, is struck by the lead strap. The strap takes the shape of the part being formed and forces it down against the form block. One advantage of this method is the metal is formed without marring or wrinkling and is not thinned as much as it would be by other methods of hand forming. This method is also illustrated in figure 4-36. After the flange is formed by either method, trim off the excess material and check the part for accuracy.

Bending on a Brake

The easiest and most accurate method of making straight-line bends in a piece of sheet metal is to use a box and pan brake or a cornice brake. The use of these brakes is relatively simple. However, if they are not used correctly, the time and the work involved in computing the bend allowance and laying out the job, as well as the metal, are wasted. Before you bend any work that must have an accurate bend radius and definite leg length, the brake settings should be checked with a piece of scrap metal. To make an ordinary bend on a brake, you should place the sheet to be bent on the bed so that the bend line is directly under the upper jaw or clamping bar. Then, pull down the clamping bar handle. This brings the clamping bar down to hold the sheet firmly in place. Next, set the stop for the proper angle or amount of bend. Finally, make the bend by raising the bending leaf until it strikes the stop. If more than one bend is to be made, bring the next bend line under the clamping bar and repeat the procedure. See figures 4-22 and 4-25.

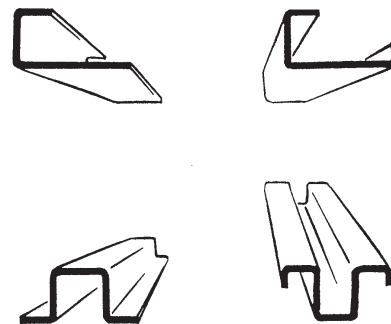

AMf04037

Figure 4-37.—Types of bends on a bar folder.

Bending on a Bar Folder

The bar folder may be used to bend and fold metal in a number of different shapes, as illustrated in figure 4-37. This machine has two adjustments: one for regulating the width of the fold and the other to provide sharp or rounded bends. To operate the bar folder, adjust the thumbscrew to the specified width of the fold. Then turn the adjusting knob on the back of the machine for the desired sharpness of the bend. Insert the metal under the folding blade until it rests against the stops. Hold the metal firmly in place with one hand, grasp the handle with the other, and pull forward until the desired fold is made.

FORMING SHEET METAL

A sheet metal object made on a brake will have corners (bends) and sides (flanges). On a forming machine, it is possible to make an object without sides. For example, you can make a circular object such as a funnel. The forming machines used in the Navy are usually located at aircraft intermediate maintenance departments (AIMDs). The two most common machines are the slip roll and the rotary.

Slip-Roll Forming

Sheet metal can be formed into cylindrical or conical shapes through the use of the slip-roll forming machine. Prior to using this machine, you should consult the manufacturer's manual of operation.

To form a cylinder in the machine, you should use the following procedures and refer to figure 4-38:

1. Adjust the front rolls so they will grip the sheet properly.
2. Adjust the rear roll to a height that is less than enough to form the desired radius of the cylinder.
3. Ensure that all three rolls are parallel. (The same space exists between any two rollers at each end of the rollers.)
4. Start the sheet into the space between the two front rolls. As soon as the front rolls have gripped the sheet, raise the free end of the sheet slightly.
5. Pass the entire sheet through the rolls. This forms part of the curve required for the cylinder.
6. Set the rear roll higher to form a shorter radius.
7. Turn the partially formed sheet end over end, and again pass it through the rolls.

8. Continue turning the sheet end over end and passing it through the rolls, each time adjusting the rear roll for a new radius, until a cylindrical shape has been formed.

9. Remove the cylinder from the machine. The top front roll has a quick-releasing device on one end. This allows the released end of the roll to be raised and the newly formed cylinder slipped off just as you would slip a ring from your finger.

Conical shapes can be formed by setting the back roll at an angle before running the sheet through it, or

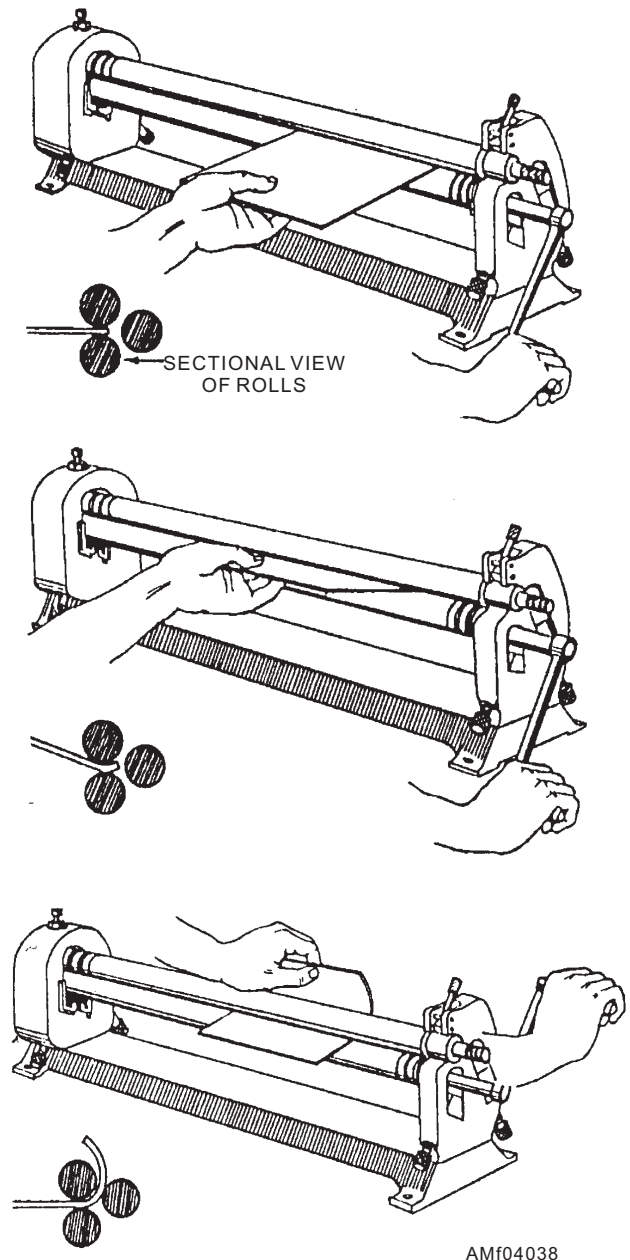

Figure 4-38.—Forming a cylinder.

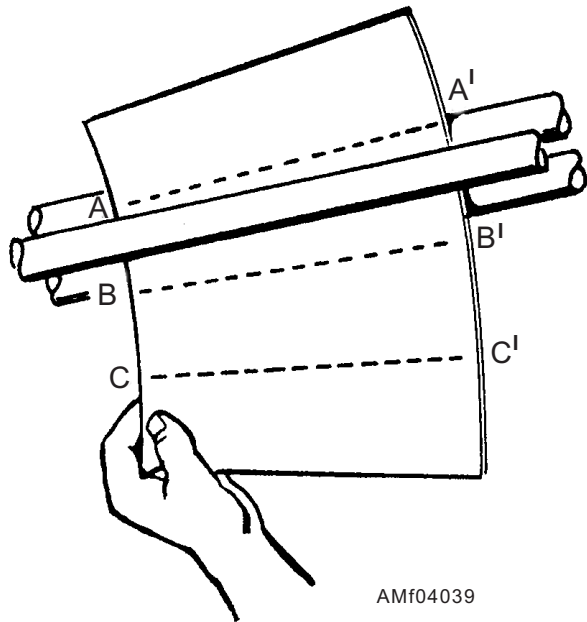

Figure 4-39.—Rolling a conical shape.

they can be made with the rolls parallel. See figure 4-39. To make a cone with the rolls parallel, the sheet must be fed through the rolls in such a manner that the element lines (A-A', B-B', etc., in the illustration) pass over the rear roll in a line parallel to the roll. This involves slipping the large end of the cone through the rolls at a slightly faster rate than the rate at which the small end is being rolled through.

The grooves at the ends of the rolls can be used to form circles of wire or rod. They can also be used to roll wired edges, as shown in figure 4-40.

Rotary Forming

The roll dies are installed on the rotary machine to perform a specific forming operation.

BEADING ROLLS.—Beading rolls are used for turning beads (grooves) on tubing, cans, and buckets.

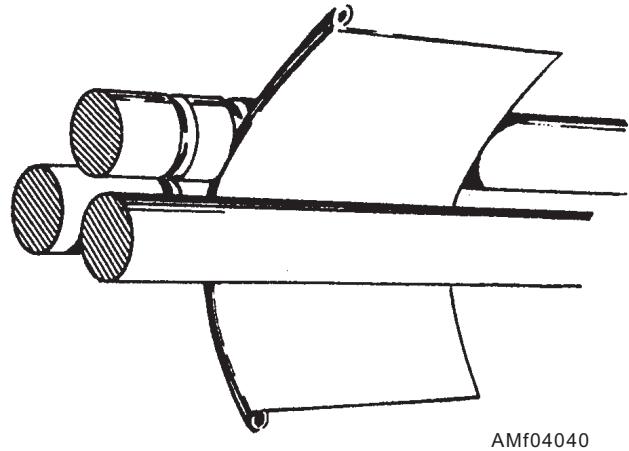

Figure 4-40.—Rolling a wired edge.

Beads may also be placed on sheet stock that is to be welded. There are several different types of beading rolls. Those shown in figure 4-41 are single bead rolls. When you are beading, the groove should not be made too deeply in a single rotation, as this tends to weaken the metal.

TURNING ROLLS.—Turning rolls are used for turning an edge to receive a stiffening wire. When you are turning an edge, rest the cylinder to be wired on the lower wheel and press against the gauge. The gauge is adjusted according to the size of wire to be used. With the work set in place, bring the upper roll down until it grips the metal. Turn the crank slowly while you are holding the metal so that the metal will feed into the rolls. Continue to press against the guide. After the first revolution, gradually raise the metal until it touches the outer face of the top roll. Remove the stock by raising the top roll.

WIRING ROLLS.—Wiring rolls are used to finish the wired edges prepared in the turning rolls. To use the wiring rolls, you should adjust the top roll so that it is directly above the point on the lower roll where

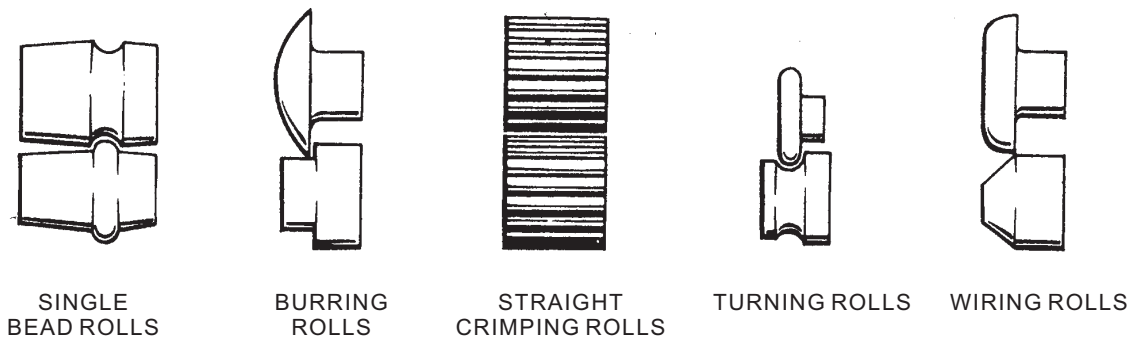

Figure 4-41.—Roll dies used on a rotary machine.

the beveled and flat surfaces meet, as shown in view A of figure 4-42. Adjust the guide to the position shown in view B, then bring the top roll down so that it will turn the edge of the metal as shown in view C. Remove the stock from the machine by raising the top roll.

CRIMPING ROLLS.—Crimping rolls are used to make one end of a pipe smaller than the other so that two sections may be slipped together, one end into the other. A bead is placed on a pipe first, and then it is crimped. The bead forms a shoulder to keep the pipe from slipping too far into the adjoining section.

BURRING ROLLS.—Burring is perhaps the most difficult operation to perform on a rotary machine. Before you place the work in the machine, make sure the cylinder or circular disc to be burred is cut or formed as perfectly round as possible. Then adjust the gauge on the machine so the space between the inside of the upper roll and the gauge is set to the width of the burr. Next, place the object between the rolls and against the gauge. Then you should lower the upper roll until it scores the material slightly. Turn the crank slowly to allow the metal to slide between thumb and fingers. Apply a slight upward pressure as the metal passes between the rolls. After the first revolution, lower the top roll and again pass the metal between the rolls. Repeat this process, raising the edge slightly with each complete revolution of the material, until the edge has been burred to the proper angle.

RIVETING PROCEDURES

You must use your knowledge, ability, and experience to plan an aircraft structural repair that involves riveting. Each rivet must be selected and driven in a precise manner to meet the riveting specification. Some of the specifications are rivet spacing and edge distance, diameter of the rivet hole, aerodynamic smoothness, and size of the rivet bucktail. These can be accomplished only through determina-

tion, practice, and accurate manipulation of all layout and riveting equipment.

Rivet Selection

The following rules should govern your selection and use of rivets:

1. Replacements must not be made with rivets of lower strength material unless they are larger than those removed. For example, a rivet of 2024 aluminum alloy should not be replaced by one made of 2017 aluminum alloy unless the 2017 rivet is a size larger. Similarly, when 2117 rivets are used to replace 2017 rivets, the next larger size should be used.
2. When rivet holes become enlarged, deformed, or otherwise damaged, you should use the next larger size as replacement.
3. Countersunk-head rivets should be replaced by rivets of the same type and degree of countersink, either AN426 or MS20426.
4. All protruding-head rivets should be replaced with universal-head rivets, either AN470 or MS20470.
5. Rivets less than three thirty-seconds of an inch in diameter should not be used for any structural parts, control parts, wing covering, or similar parts of the aircraft.
6. Minimum rivet diameter is equal to the thickness of the thickest sheet to be riveted.
7. Maximum rivet diameter is three times the thickness of the thickest sheet to be riveted.
8. The proper length of rivet is an important part of the repair. If the rivet is too long, the formed head will be too large, or the rivet may bend or be forced between the sheets being riveted. If the rivet is too short, the formed head will be too small or the riveted material will be damaged. The length of the rivet should

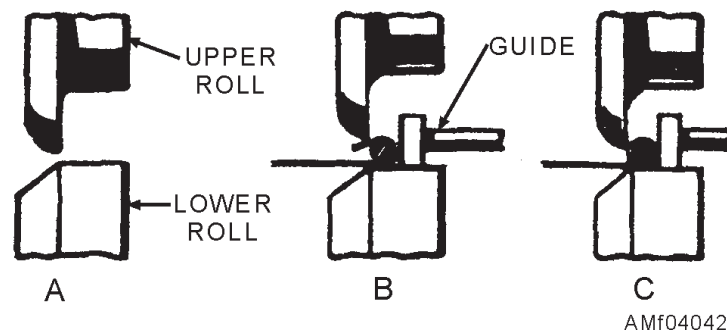

Figure 4-42.—Wiring operation.

equal the sum of the thickness of the metal plus 1 1/2 times the diameter of the rivet, as shown in figure 4-43. The formula for determining rivet length is as follows:

$$1 \frac{1}{2} \times D + G = L$$

Where:

D = the rivet diameter,

G = the grip (total thickness of material, and

L = the total length of the rivet.

Spacing and Edge Distance

Rivet spacing, also referred to as rivet pitch, is the distance between the rivets in the same row, and is measured from the rivet center to the rivet center. Transverse pitch is the distance between the rows of rivets, and is measured from the rivet center to rivet center. Edge distance is the distance from the center of the rivet to the edge of the material being riveted.

There are no specific rules that apply to every case or type of riveting. There are, however, certain general rules that should be followed.

RIVET SPACING.—Rivet spacing (pitch) depends upon several factors, principally the thickness of the sheet, the diameter of the rivets, and the manner in which the sheet will be stressed. Rivet spacing should never be less than three times the rivet diameter. Spacing is seldom less than four times the diameter nor more than eight times the diameter.

TRANSVERSE PITCH.—When two or more rows of rivets are used in a repair job, the rivets should be staggered to obtain maximum strength. The distance between the rows of rivets is called “transverse pitch.” Transverse pitch is normally 75 percent of existing rivet pitch, but should never be less than 2 1/2 times the diameter.

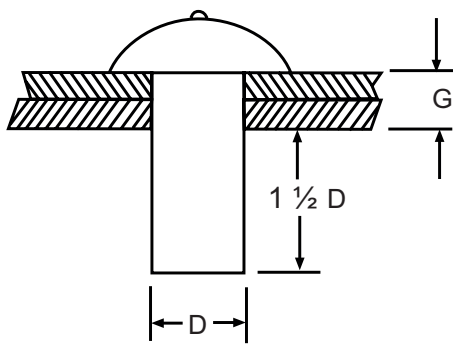

G - GRIP (TOTAL THICKNESS)
D - DIAMETER OF RIVET
 $1 \frac{1}{2} D + G = \text{TOTAL LENGTH OF RIVET}$

AMf04043

Figure 4-43.—Rivet length.

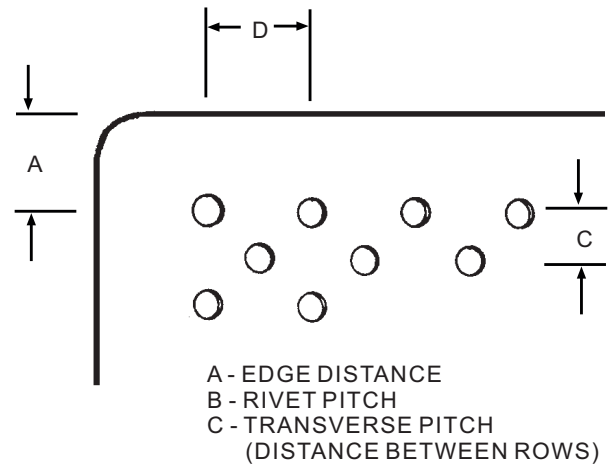

A - EDGE DISTANCE
B - RIVET PITCH
C - TRANSVERSE PITCH
(DISTANCE BETWEEN ROWS)

AMf04044

Figure 4-44.—Rivet spacing and edge distance.

EDGE DISTANCE.—The edge distance for all rivets, except those with a flush head, should not be less than twice the diameter of the rivet shank nor more than four times the diameter of the rivet shank. Flush-head rivets require an edge distance of at least 2 1/2 times the diameter. If rivets are placed too close to the edge of the sheet, the sheet is apt to crack or pull away from the rivets. If they are placed too far away from the edge, the sheet is apt to turn up at the edge.

NOTE: On most repairs, the general practice is to use the same rivet spacing and edge distance that the manufacturer used in the surrounding area, or the structural repair manual for the particular aircraft may be consulted. Figure 4-44 shows rivet spacing and edge distance.

Drilling Rivet Holes

Standard twist drills are used to drill rivet holes. Table 4-2 specifies the size drill to be used with the various size rivets. Note that there is a slight clearance in each case. This prevents binding of the rivet in the hole.

Table 4-2.—Drill Sizes for Various Size Rivets

Rivet Diameter	Drill No.	Drill Size
3/32	No. 41	0.0960
1/8	No. 30	.1285
5/32	No. 21	.1590
3/16	No. 11	.1910
1/4	No. F	.2570
5/16	No. P	.3230
3/8	No. W	.3860

Locations for the rivet holes should be center punched and the drilling done with a power drill, either electric or pneumatic. Electric drills constitute a fire hazard when you are drilling on or near an aircraft. The hazard is caused by the arcing of the brushes. Therefore, the pneumatic drill should be used. The center punch mark should be large enough to prevent the drill from slipping out of position, but must not be made with enough force to dent the surrounding material. All burrs must be removed by using a larger size drill or by using a deburring tool.

Flush Riveting

In aircraft construction, manufacturers are eliminating protruding-head rivets on the exterior surfaces. In fabricating stressed metal skin, all exposed rivet heads must be countersunk to lie flush with the outer surface of the skin. It is essential to provide an aerodynamically smooth surface. See figure 4-45.

Flush rivets are more difficult to install because the parts being riveted must be countersunk. Another hazard is the closeness of the rivet set to the metal during riveting. If considerable skill is not used, the rivet set will damage the metal. Flush rivets are made with heads of several different angles, but the 100-degree rivet is standard for all Navy aircraft.

The two methods used to countersink flush rivets are dimple and machine countersinking. In some instances, a combination of the two may be used; in other words, the top sheet of an assembly may be dimpled while the under sheet is machine countersunk.

Rivet Driving

Before driving any rivets, make sure all the holes line up perfectly, all the shavings and burrs have been removed, and the parts to be riveted are fastened

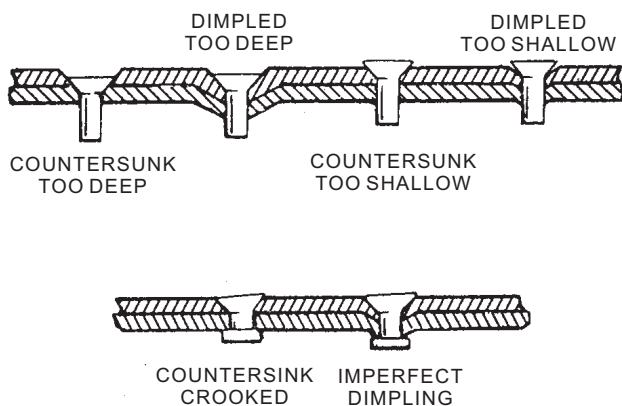

AMf04045

Figure 4-45.—Incorrect countersinking.

securely together. It is important that the sheets be held firmly together near the area of the rivet being driven.

To adjust the speed of the gun, place it against a block of wood. Never operate a rivet gun without resistance against the set. The vibrating action may cause the retaining spring to break, allowing the set to fly out.

WARNING

A rivet set can be a deadly weapon. If a rivet set is placed in a rivet gun without a set retainer and the throttle of the gun is opened, the rivet set may be projected like a bullet. This may cause severe injury to a person or destruction of equipment.

The gun should be adjusted so the rivet can be driven in the shortest possible time, but you must take care not to drive the rivet so hard or in such a manner as to dimple the metal. Practice will enable you to properly adjust a gun for any type of work.

The rivet should be pushed into proper position and held there firmly, with the set of the rivet gun resting squarely against the rivet head. The bucking bar is held firmly and squarely against the protruding rivet shank. (In most instances, another person, called the “bucker” must manipulate the bucking bar.) The gunner then exerts pressure on the trigger and starts driving. The gun must be held tightly against the rivet head, and it must not be removed until the trigger has been released.

The bucker removes the bucking bar and checks the upset head after the gunner has stopped driving. A signal system is usually employed to develop the necessary teamwork, and consists of tapping lightly against the work. One tap may mean, “not fully driven, hit it again”; two taps may mean “good rivet”; three taps may mean, “bad rivet, remove and drive another.”

The upset head, often referred to as the bucktail, should be 1 1/2 times the original diameter of the shank in width and 1/2 times the original diameter in height, as shown in figure 4-46. If the head formed is narrower

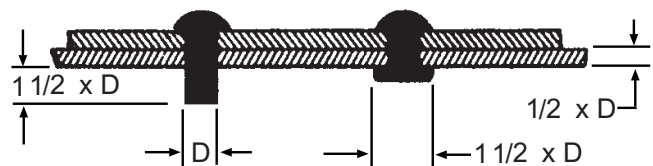

AMf04046

Figure 4-46.—Rivet dimensions before and after bucking.

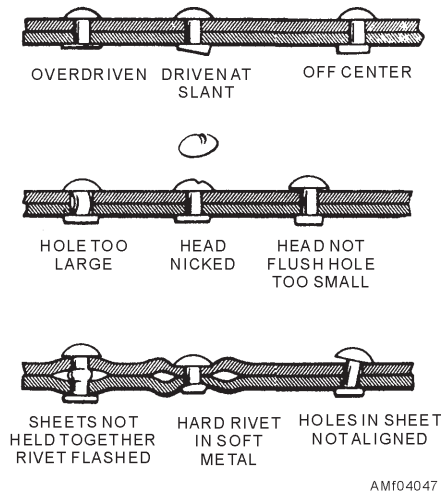

Figure 4-47.—Incorrectly driven rivets.

and higher than the dimensions given, more driving is necessary. If it is wider and shallower, it must be removed and replaced.

Rivet Removal

Rivets must be removed and replaced if they show even the slightest deformity or lack of alignment. Reasons for replacing rivets are as follows: rivet marred by bucking bar or rivet set; rivet driven at slant or shank bent over; rivet too short, causing the head to be shallow; rivet pancaked too flat from overdriving; sheets spread apart and rivet flashed between the sheets; two rivet heads not in alignment; and head of countersunk rivet not flush with outside surface or driven below surface. Examples of these incorrectly driven rivets are shown in figure 4-47.

When you are removing rivets, be careful not to enlarge the rivet hole. This will require you to use a larger size rivet for replacement. To remove a rivet, file a flat surface on the manufactured head. It is always preferable to work on the manufactured head rather than on the one that is bucked, since the former will always be more symmetrical about the shank. Indent the center of the filed surface with a center punch, and use a drill of slightly less than shank diameter to drill through the rivet head. Remove the drill and, with the other rivet end supported, pry or lightly tap off the head with a drift punch. If the shank is too tight after the removal of the head, the shank should be drilled out. However, if the sheet is firmly supported from the opposite side, the shank may be punched out with a drift punch. See figure 4-48.

The removal of flush rivets requires slightly more skill. If the formed head on the interior is accessible and

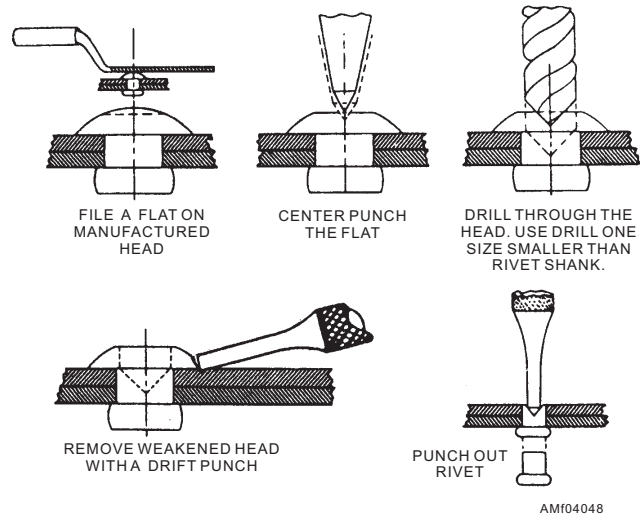

Figure 4-48.—Removal of rivets.

has been formed over heavy material, such as an extruded member, the formed head can be drilled through and sheared off. If the material is thin, it may be necessary to drill completely through the shank of the rivet, and then cut the formed head with diagonal-cutting pliers. The remainder of the rivet may then be drifted out from the inside.

BLIND RIVET INSTALLATION

The description and use of blind rivets are covered in chapter 2 of this manual. The special tools and installation and removal methods are covered in the following sections. Selection of the proper equipment depends on a number of variables: space available for equipment, type of rivets to be driven, and the availability of air pressure.

Installation Tools

One of the tools used for driving huck rivets is the CP350 blind rivet pull tool. See figure 4-49. The nose of

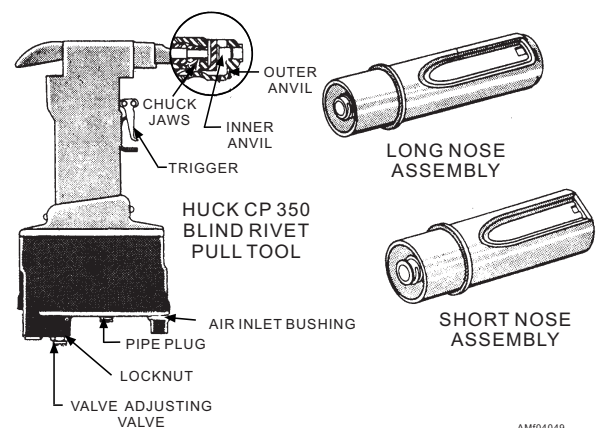

Figure 4-49.—Self-plugging rivet (mechanical lock) pull tool.

the tool includes a set of chuck jaws that fit the pull grooves in the rivet pin to pull it through the rivet shank to drive the rivet. The nose also has an outer anvil that bears against the outer part of the manufactured head during the driving operation. The third nose component is an inner anvil that advances automatically to drive the locking collar home after the blind head is formed. A short nose assembly, interchangeable with the standard assembly, is available for use in areas of restricted clearance.

A change in rivet diameter requires a change in chuck jaws, outer anvil, inner anvil, and inner anvil thrust bearing, and an adjustment of the shift valve operating pressure. A change in the rivet head type from universal head to countersunk head without a change in rivet diameter, or vice versa, requires only a change of the outer anvil.

A special chuck jaw assembly tool is furnished with the tool. To insert the chuck jaws into the chuck sleeve, you should mount the three jaws on this assembly tool to form a cone. Then lower the inverted chuck sleeve over the jaws. You should always be sure that the pull tool is equipped with the correct size chuck jaws, the outer and inner anvils fit the rivets being driven, and the relief valve operating pressure is properly adjusted for the size rivets being driven. Also make sure that the rivets are of proper length. The tool has only one operating adjustment. This adjustment is used to control the pull on the pin. The desired amount of the pull depends on the diameter of the rivets to be installed. The pull is varied by changing the pressure at which the adjustable shift valve operates. To adjust the pressure, proceed as follows:

1. Remove the pipe plug from the tool cylinder and connect a pressure gauge to the tool.
2. Press the trigger and release it the instant a puff of exhaust indicates the shift valve controlling the inner anvil has shifted. The gauge will then indicate the shift pressure. See table 4-3 for the approximate pressures.

Table 4-3.—Adjustments for CP350 Blind Rivet Pull Tool

Rivet Diameter	Shift Valve Operating Pressure
1/8	30 to 31 psi
5/32	46 to 47 psi
3/16	66 to 67 psi

NOTE: The trigger must be released immediately as the valve shifts. Otherwise the gauge will record the

higher pressure that builds up after the valve has shifted.

3. To adjust the pressure, loosen the valve adjusting screw locknut and turn the valve-adjusting screw clockwise to increase pressure, or counterclockwise to decrease pressure, until the desired pressure is obtained. Check the pressure after tightening the valve-adjusting screw locknut. When you drive rivets of extremely long grip length, you should make an adjustment to the high-pressure limit. For efficient operation of the tool, the minimum desired line pressure should be not less than 90 psi and the maximum not more than 110 psi.

When you are using a CP350A or B rivet pull tool, it may be necessary to increase the inside diameter of the air inlet bushing, part number 81479, from 0.055 to 0.065 of an inch when you are driving 3/16-inch-diameter rivets, if the line pressure is below 90 psi. When you are driving 1/8-inch-diameter rivets, it may be necessary to use an air inlet bushing, part number 82642 that has a 0.040-inch inside diameter. If the tool “flutters,” reduce the line pressure to 60 psi with an air regulator, part number 900-102, attached to the air inlet bushing.

When you are using a CP350C rivet pull tool to drive 1/16- and 5/32-inch-diameter rivets, use the air inlet bushing, part number 81479, and the shift valve stop, part number 83731. When you are driving 1/8-inch-diameter rivets with the CP350C, use the air inlet bushing, part number 83642, and reduce the line pressure to 60 psi with an air regulator, part number 900-102, attached to the air inlet bushing.

The equipment used for the installation of cherrylock rivets is similar to the huck rivet. See figure 4-50. The operation and adjustment of the pulling heads

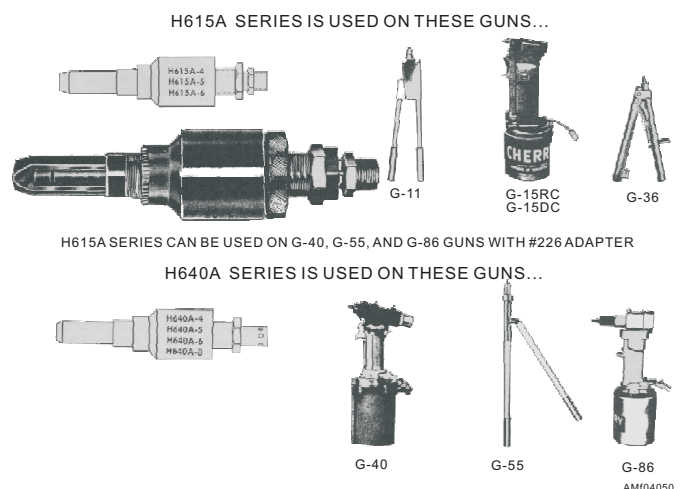

Figure 4-50.—Cherrylock guns.

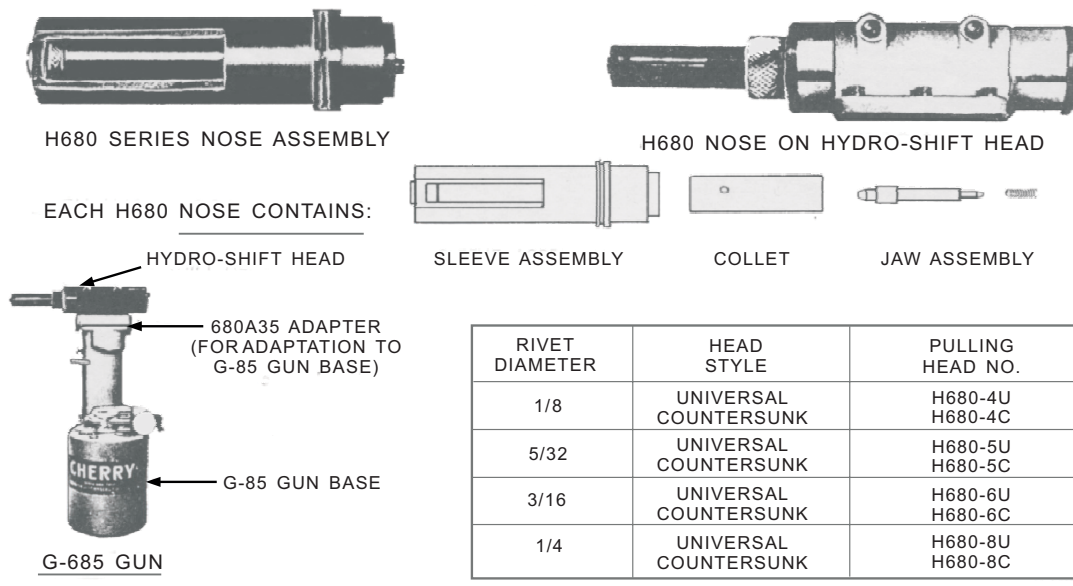

Figure 4-51.—Hydro-shift series gun.

AMf04051

are preset during manufacture. If further adjustment should become necessary, the procedures provided with the head or in the maintenance manual should be followed. To install a pulling head of the H615A series, engage the threaded portion of the pulling head sleeve cap and drawbolt to the gun head and drawbolt. Then tighten the screws and the jam nut. The pulling head of an H640A series is installed by engaging the internal threads of the head piston rod. Then align the holes in the pulling head with those on the gun adapter, and tighten one setscrew.

To install the nose assembly used on the hydro-shift head equipped gun, shown in figure 4-51, you should proceed as follows:

1. Remove the retainer nut from the hydro-shift head.

2. Place the jaw assembly in the collet (with the spring protruding).
3. Screw the internal threads of the collet onto the drawbolt of the hydro-shift head.
4. Slip the sleeve assembly over the collet.
5. Place the retainer nut over the sleeve assembly and tighten it onto the gun.

Cherrylock rivets require a separate pulling head for each diameter and head style. Each series of gun also uses a different set of pulling heads. Refer to the appropriate operating manual for the proper head for each rivet and gun.

There are also special use cherrylock pulling heads, shown in figure 4-52, for use in areas where access is limited. Since huck and cherrylock rivets are similar,

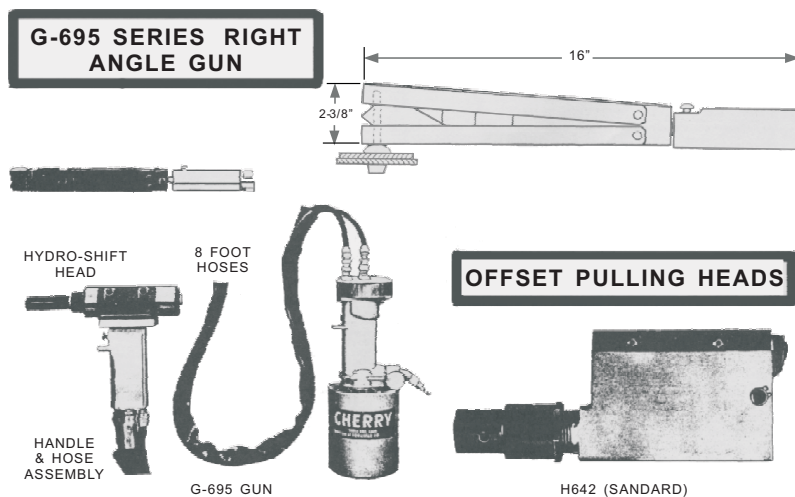

Figure 4-52.—Special use heads.

AMf04052

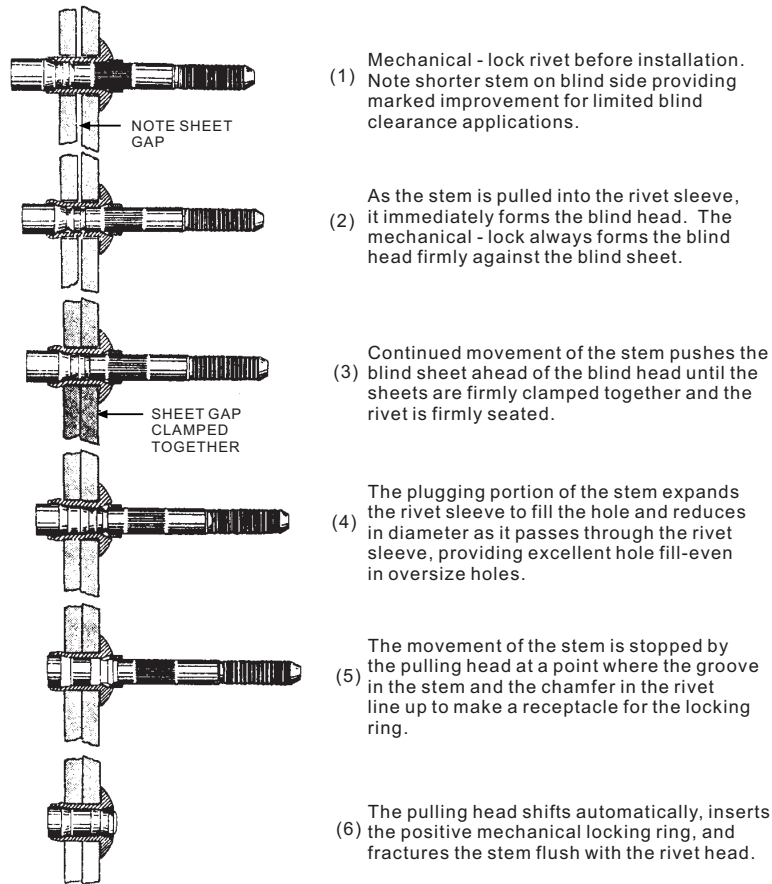

Figure 4-53.—Self-plugging rivet (mechanical lock).

the installation, inspection, and removal procedures are basically the same.

Installation Procedures

Proper driving procedures are vital to obtain a firm joint. The recommended procedures are as follows:

1. Hold the head of the gun steady and at right angles to the work.
2. Press on the head of the gun hard enough to hold the rivet firmly against the work. Do not use a great amount of pressure unless it is necessary to bring the part being riveted into contact.
3. Squeeze the gun trigger and hold it until the rivet pin breaks, and then release the trigger. The next rivet should not be driven until the return action has caused the gun to latch. A distinct click will be heard. The click indicates the gun is ready for the next installation cycle.

Figure 4-53 shows the complete installation of a self-plugging (mechanical lock) rivet.

The rivet is actually cold squeezed by the action of the pinhead drawing against the hollow shank end.

Shank expansion through the action of the extruding angle, blind head formation, and setting of the mechanical lock in the rivet head all follow in sequence and require but a fraction of a second.

In some places, such as near the trailing edge of a control surface, there may not be sufficient space between the two surfaces to insert the rivet. In such cases, the pin may be forced into the hollow shank until the head of the pin touches the end of the shank. Since no further shank expansion will result, the drill hole should not be enlarged to provide a free fit of the already expanded rivet. To insert the rivet, you should use a hollow drift pin that will accommodate the rivet pin and the locking collar. See figure 4-54. This allows a driving force to be exerted on the head of the rivet. Drive the head into firm contact with the sheet, and then

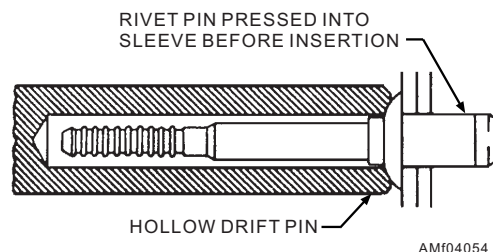

Figure 4-54.—Inserting self-plugging rivet (mechanical lock).

apply the rivet pull tool in the usual manner to upset the rivet.

Because of the mechanical lock feature of the pin and sleeve, the driven rivet is substantially the mechanical equivalent of a one-piece solid rivet.

Inspection

Visual inspection of the seating of the pin in the manufactured head is the most reliable means of inspection. If the proper grip length has been used and the locking collar and broken end of the pin are approximately flush with the manufactured head, the rivet has been properly upset and the lock formed. Insufficient grip length is indicated by the pin breaking below the surface of the manufactured head. Excessive grip length is indicated by the pin breaking off well above the manufactured head. In either case, the locking collar might not be properly seated and an unsatisfactory lock would be formed.

Removal

Removal of this rivet can be accomplished easily and without damage to the work if you use the following procedures. See figure 4-55.

1. Shear the lock by driving out the pin with a tapered steel drift pin not over 3/32-inch diameter at the small end. If inaccessibility

prohibits this, partially remove the rivet head by filing or with a rivet shaver. An alternative would be to file the pin flat, center punch the flat, and carefully drill out the tapered part of the pin forming the lock.

2. Pry the remainder of the locking collar out with a drift pin.

3. Use the proper size drill to drill almost completely through the rivet head. For a 1/8-inch-diameter rivet, use a No. 31 drill; for a 5/32, use a No. 24; and for a 3/16, use a No. 15.

4. Break off the drilled head with a drift pin.

5. Drive out the remainder of the rivet with a pin that has a diameter equal to or slightly less than the rivet diameter.

Q4-18. What is the most commonly used layout fluid?

Q4-19. What is the only thing you should use a scribe for when laying out aluminum or magnesium?

Q4-20. The amount of material consumed in the bending process is known by what term?

Q4-21. What is the outside dimension of the formed part called?

Q4-22. The setback is the combination of the metal thickness and what other factor?

Q4-23. Machines used to cut sheet metal are classified into what two groups?

Q4-24. When using a vise and forming blocks to manually form a part, what are the three materials that the mallet you use must be made from?

Q4-25. When you cut sheet metal, how much should you add to allow for trim?

Q4-26. Before making any bends on the layout, what should you do to make sure the brake settings are right?

Q4-27. How many adjustments must be checked on the bar folder before you can properly bend and fold metal?

Q4-28. To form cylindrical or conical shapes, you should use what machine?

Q4-29. What machine should you use to make a groove on a bucket?

Q4-30. What determines the minimum rivet diameter?

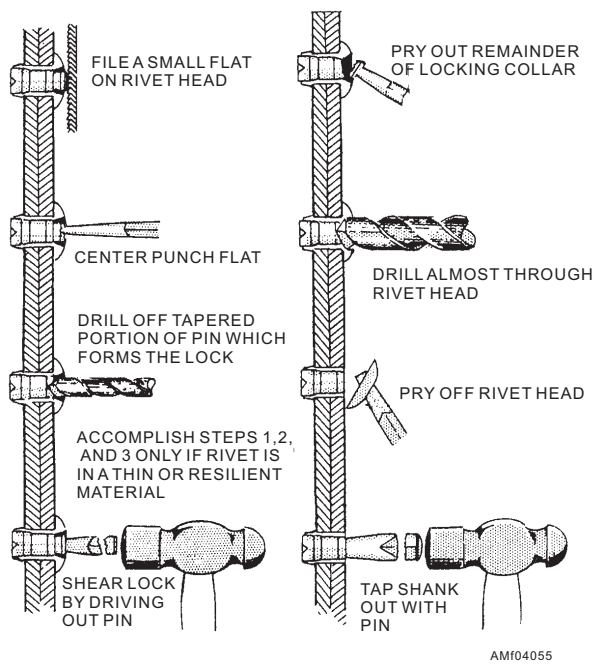

Figure 4-55.—Removing self-plugging rivets (mechanical lock).

- Q4-31. What is the Navy standard countersink angle?
- Q4-32. A CP350 blind rivet tool is used to pull what type of rivet?
- Q4-33. When drilling out a self-plugging rivet, what size drill bit would you use to drill a 1/8-inch rivet?

AIRCRAFT METALLIC REPAIR

LEARNING OBJECTIVE: Recognize the causes of damage to metallic structures. Identify the procedures for repair of metallic structures.

One of the most important jobs you will encounter is the repair of damaged skin and material. All repairs must be of the highest quality and must conform to certain requirements and specifications. You must be familiar with the principle of streamlining, the behavior of various metals in high-velocity air currents, and the torsioned stress encountered during high-speed flying and maneuvering.

DAMAGE REPAIRS

When any part of the airframe has been damaged, the first step is to clean all grease, dirt, and paint in the vicinity of the damage so the extent of the damage may be determined. The adjacent structure must be inspected to determine what secondary damage may have resulted from the transmission of the load or loads that caused the initial damage. You should thoroughly inspect the adjacent structures for dents, scratches, abrasions, punctures, cracks, loose seams, and distortions. Check all bolted fittings that may have been damaged or loosened by the load that caused the damage to the structure.

Causes of Damage

Damages to the airframe are many and may vary from those that are classified as negligible to those that are so extensive that an entire member of the airframe must be replaced. The slightest damage could affect the flight characteristics of the aircraft. The most common causes of damage to the airframe are collision, stress, heat, corrosion, foreign objects, fatigue, and combat damage.

COLLISION.—This type of damage is often the result of carelessness by maintenance personnel. It varies from minor damage, such as dented or broken

areas of skin, to extensive damage, such as torn or crushed structural members and misalignment of the aircraft. You should exercise extreme care in all ground-handling operations.

CORROSION.—Damage to airframe components and the structure caused by corrosion will develop into permanent damage or failure if not properly treated. The corrosion control section of the maintenance instructions manual describes the maximum damage limits. These limits should be checked carefully, and if they are exceeded, the component or structure must be repaired or replaced.

FATIGUE.—This type of damage is more noticeable as the operating time of the aircraft accumulates. The damage will begin as small cracks, caused by vibration and other loads imposed on skin fittings and load-bearing members, where the fittings are attached.

FOREIGN OBJECT.—This damage is caused by hand tools, bolts, rivets, and nuts left adrift during ground operations of the aircraft. Because of jet aircraft design, large volumes of air are required for its efficient operation. During ground operations, the inlet ducts induce a strong suction that picks up objects that are left adrift. Therefore, it is of utmost importance that the area around the aircraft be clean and free of foreign material before ground operations begin.

COMBAT.—Damage from enemy gunfire is usually quite extensive and often not repairable. When a projectile strikes sheet metal, it heats the metal in the vicinity of the damage. The metal becomes brittle around the damaged area as a result of the heat, and minute cracks are created by the impact of the projectile. These cracks open up under vibration. If the projectile passes through the component or structure, it will leave a larger hole on the opposite side from where it entered. The repair procedures for combat damage should be followed with extreme care only after a rigid inspection of the damage has been completed in accordance with the *General Manual for Aircraft Battle Damage Repair*, NAVAIR 01-1A-39.

HEAT.—Certain areas of high-performance aircraft are exposed to high temperatures. These areas usually include the engine bleed lines, fuselage sections around the engine, the aft fuselage and horizontal stabilizer, and the wing sections around the boundary layer control system. Some aircraft structural repair manuals include diagrams that illustrate the heat danger areas.

STRESS.—This type of damage is usually identified by loosened, sheared, or popped rivets; wrinkled skin or webs; and cracked or deformed structural members. This damage is usually caused by violent maneuvers or hard landings. When the pilot reports these discrepancies on the yellow sheet, a thorough inspection of the entire aircraft must be performed.

Investigation of Damage

There are three methods that can be used to ensure a thorough investigation has been made. The three methods are visual inspection, hardness testing, and nondestructive inspection for cracks.

VISUAL INSPECTION.—A thorough inspection of the structure should be made for dents, scratches, abrasions, punctures, cracks, distortion, loose joints, breaks, and buckled or wrinkled skin. All riveted and bolted joints in the vicinity of the damaged area should be checked for elongated holes and loose, sheared, or damaged rivets or bolts. If any doubt exists about the failure of a rivet or bolt, the fastener should be removed for a more thorough inspection. All access panels, hatches, and doors should be opened to inspect the internal structure. A borescope (precision optical instrument) can be used for the inspection of the internal structure. By using this instrument, areas may be examined without being disassembled. You can view the area through the eyepiece.

The adjacent structure should be inspected to determine if secondary damage has resulted from the transmission of shock or the load that caused the primary damage. A shock at one end of a structural member may be transmitted to the opposite end of the member and cause rivets to shear or other damage. When you estimate the extent of damage, be sure that no secondary damage remains unnoticed.

Every precaution must be taken during the inspection to ensure that all corrosion is detected, especially in places where it will not be visible after repair. Past experience has proven that corrosion occurs more often in parts of the structure that are poorly ventilated and in inaccessible corners of internal joints that prevent proper water drainage.

HARDNESS TESTING.—When fire has damaged the airframe, the paint will be blistered or scorched and the metal will be discolored. When these conditions exist, the affected area should first be

cleaned and the paint removed. Following this, a hardness test should be conducted to determine if the metal has lost any of its strength characteristics. This test can be performed with the Barcol or Riehle portable hardness tester. If the material to be tested is removed from the airframe, then a more reliable test can be made by using a standard bench tester. If the alloy to be tested is either clad or anodized, the surface coating must be removed to the bare metal at the point of penetrator contact. This is necessary because clad surfaces are softer and anodized surfaces are harder than the base alloy.

INSPECTION FOR CRACKS.—The existence of suspected cracks or the full extent of apparent cracks in structural members cannot be accurately determined by visual inspection. In cases where it is necessary for cracks to be accurately defined, a nondestructive inspection is usually performed.

Fittings should receive a special investigation if they are cracked, since this could cause an entire component to fail. Fittings are used to attach sections of wings together and wings to fuselage, as well as attachment of stabilizers, control surfaces, landing gear, and engine mounts. The penetrant method of inspection can be used to detect surface cracks in fittings and the magnetic particle method used to detect subsurface cracks in ferrous fittings.

CLEANUP OF DAMAGE.—Along with the investigation of damage, you should clean all jagged holes, tears, or damaged material. The cleaned sections must include all the area in which minute cracks are present. The affected area must be cut and rounded to form a smooth regular outline. If a rectangular- or square-shaped cutout is made, the radii for the corners should be a minimum of one-fourth inch, unless otherwise specified. All burrs should be removed from the edges of the cutout.

All dented plates should be restored to their original shape if possible. Shallow abrasions or scratches should be burnished with a burnishing tool that will compress the projecting metal along the edges down into the scratch. Burnishing has no cutting action and removes no metal. When surface irregularities are smoothed by burnishing, the stress concentration will be lessened.

NOTE: Deep scratches and abrasions must be treated as complete breaks.

Classification of Damage

After the extent of damage has been determined, it should be classified in one of the following categories: negligible damage, damage repairable by patching, damage repairable by insertion, or damage requiring replacement of parts. See figure 4-56.

Before proceeding with the repair of the airframe, it is necessary that the applicable structural repair manual be consulted for the procedures and materials to be used. If the applicable manual is not available, the *General Manual for Structural Repair*, NA 01-1A-1, may be used. If any conflict should exist between the two manuals, the specific manual takes precedence.

NEGLIGIBLE DAMAGE.—Negligible damage is that damage or distortion that may be allowed to exist as is or corrected by some simple procedure, such as removing dents, stop-drilling cracks, burnishing scratches or abrasions, without placing a restriction on

the flight status of the aircraft. Before classifying damage as negligible, make sure the damage complies with the manufacturer's specified limits of negligible damage.

DAMAGE REPAIRABLE BY PATCHING.—Damage that can be repaired by installing a reinforcement or patch to bridge the damaged portion of a part may be classified as a damage repairable by patching. Reinforcement members are attached to the undamaged portions of the part to restore full load-carrying characteristics and airworthiness of the aircraft. Damage repairable by patching is specified for each member of the airframe.

DAMAGE REPAIRABLE BY INSERTION.—Damage that is extensive enough to involve a major portion of a member, but which is not so extensive as to require replacement, is classified as damage repairable by insertion. You make this repair by inserting a new section and splicing it to the affected member.

DAMAGE REQUIRING REPLACEMENT.—Damage that cannot be repaired by any practical means is classified as damage requiring replacement. Short structural members usually must be replaced because repair of such members is generally impractical.

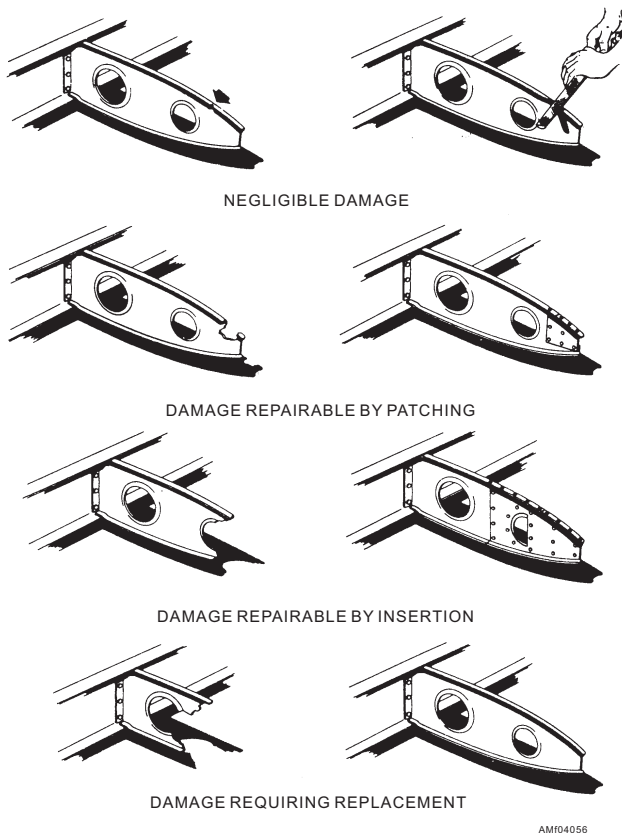

Figure 4-56.—Classifications of damage.

DAMAGE REPAIR PROCEDURES

Damage repair procedures vary greatly from aircraft to aircraft and the type of repair that is going to be performed. Also consult the applicable aircraft MIMs and the applicable aircraft structural repair manual before performing any structural repairs.

Selection of Repair Material

The major requirement in making a repair is the duplication of strength of the original structure. You should consult the structural repair manual for the aircraft concerned for the alloy thickness and temper designation of the repair material to be used. This manual will also designate the type and spacing of rivets or fasteners to be used in the repair.

In some instances, substitutions of materials are allowed. When you are making a substitution of materials and conflicting information between manuals exists, the structural repair manual for the aircraft being repaired should be used.

You have several steps to take to find the correct repair materials and procedures in a structural repair manual. Figure 4-57 shows each of the steps.

NOTE: The aircraft structural repair manual, shown in figure 4-57, was selected as a typical manual. The procedures that follow are typical but are not standard. Various manufacturers use different methods to indicate the types of materials used and special instructions for using their particular manual.

1. The extent of the damage to the aircraft is determined by the inspection of the damaged area, as previously explained.

2. Using a master index diagram, identify the damaged group of the aircraft. From the table shown on the diagram, determine the section of the manual where the component is found.

3. After locating the correct group master index diagram, obtain the correct item number for the damaged component from the illustration.

4. Find the index number for the damaged unit from the component diagram.

5. The index number is then matched with the item number on the repair material chart. This chart will normally give the part's description, drawing number, gauge, type of material, and location of repair diagram.

6. You can find the repair diagram by locating the required section of the manual and turning to the correct figure in that section. Access provisions and negligible damage information are given on the repair diagrams. After the damage has been cleaned, determine whether or not the damage is negligible

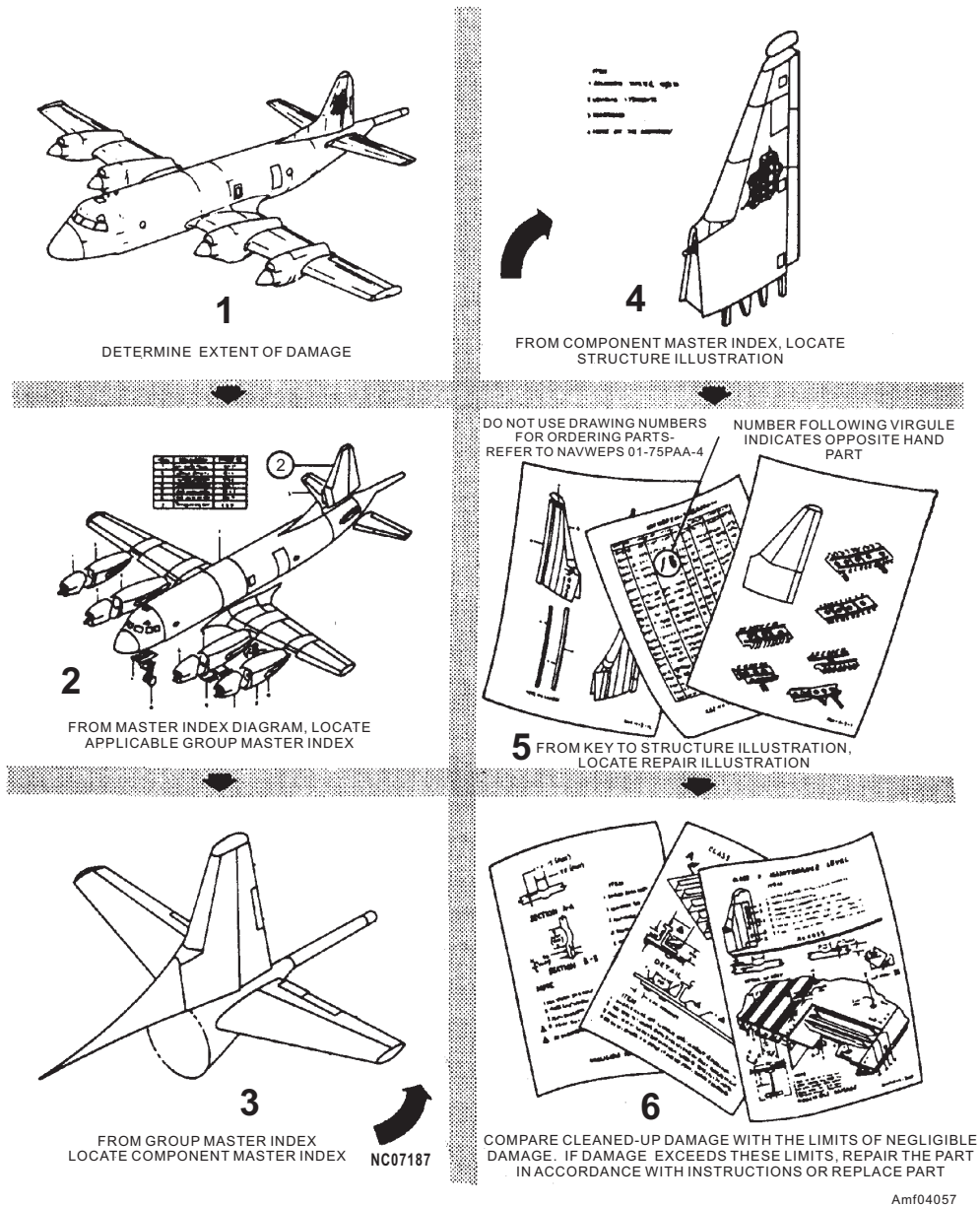

Figure 4-57.—How to use a structural repair manual.

according to the repair diagram. If the damage is within the limits of negligible damage, it may be disregarded unless it is necessary to close the hole for aerodynamic smoothness. If the damage exceeds the limits of negligible damage, it must be repaired according to the repair diagram or replaced.

Layout for Repair

Information needed to fabricate replacement parts is usually found on blueprints, while information concerning repairs may be found in the aircraft structural repair manual. The manual contains information on extrusions and the necessary data for the fabrication of various sheet metal equivalents.

The aircraft structural repair manual will indicate the type of material to be used in each repair. If the correct material is not available, the *General Manual for Structural Repair*, NAVAIR 01-1A-1, should be checked for an acceptable substitute.

The fabrication of sheet metal parts for internal structural repair requires careful adherence to the accepted standards of aircraft sheet metal work. This includes accurate calculation of bend allowance and careful layout of all dimensions. Layout is the interpreting and transcribing of information from blueprints, drawings, or written instructions for the metal that will be made into a part for an aircraft.

If several parts are to be fabricated, the dimensions may be transferred to a template. Working from a template ensures a higher degree of uniformity and speeds production.

The procedure for making a layout either for a template or for the actual part is essentially the same. Layout of a part or a template consists principally of marking the flat sheet so that all drilling, cutting, bending, and forming operations are indicated on the sheet. It is a comparable level 3 drawing that has been marked up in sufficient detail to clearly indicate the fabrication requirements for each piece/part.

The sheet metal layout may be made from printed instructions, but it is more often made directly from the blueprint. Accuracy in all details is essential. You should not transfer dimensions directly from the blueprint to the layout because the print material may have stretched or shrunk, which causes minor distortion of the dimensions. Measurements indicated on the blueprint are made on the layout.

Details are often left out and must be developed in the shop. You may, for example, find that you must add

several dimensions, and then figure the bend allowance for the material consumed in each bend before you are able to lay out the overall length or width of a part.

On very accurate layouts, a magnifying glass is frequently used as an aid to precision work. A magnifying glass enlarges the graduations on a scale and makes them easier to read. It helps locate center punch marks, and it allows a close inspection of the accuracy of the completed layout.

Use the same layout procedures to lay out material for repairs that you used for sheet metal repairs. In the layout of a part, you should plan the bending and forming operations so that each step is made in the proper sequence. If the steps are not made in the proper sequence, the part may become so bulky that it will be impossible to insert in the brake to make the final bend.

Since layout of replacement parts involves the interpretation of blueprints, you should review *Blueprint Reading and Sketching*, NAVEDTRA 14040.

TYPES OF REPAIRS

The type of repair to be made will depend on the materials, tools, amount of time available, accessibility to the damaged area, and maintenance level. The types of repair are permanent, temporary, and one-time flight (ferry). Repairs are also classified as either internal or external.

A permanent repair is one that restores the strength of the repaired structure equal to or greater than its original strength and satisfies aerodynamic, thermal, and interchangeability requirements. This ensures the designed capabilities of the aircraft.

The temporary repair restores the load-carrying ability of the structure but is not aerodynamically smooth or able to satisfy interchangeability requirements. This repair should be replaced by a permanent type as soon as possible in order for the aircraft to be restored to its normal condition.

The one-time flight repair restores a limited load-carrying ability to the damaged structure in order to fly the aircraft to a depot maintenance activity for a permanent repair. When this type of repair is made, the aircraft cockpit should be placarded to limit the performance of the aircraft.

External Repair

After the damage has been inspected and classified on external surfaces, the structural repair manual for the

specific aircraft should be consulted for the critical areas where aerodynamic smoothness must be maintained. An aerodynamic filler is available for negligible damage, steps, and gaps. In many sections the skin is Chem-Milled or machined. Chem-Mill is a process whereby the proper shape and size are obtained by a chemical acting on the metal. The proper shape and thickness of machined skin are obtained with the use of a shaper or milling machine. Some skin is manufactured with lands on the metal, which is a thicker portion of the skin where bulkheads and frames are attached.

One of the factors that determine the exact procedure to be used in making skin repairs is the accessibility of the damaged area. Much of the skin on an aircraft is inaccessible from the inside. The skin in such areas is referred to as “closed skin.” Skin that is accessible from both sides is called “open skin.” Repairs to open skin may usually be made in the conventional manner using specified types of standard rivets. To repair closed skin, some types of special blind fasteners must be used. The exact type of fastener used will depend upon the type of repair made and the recommendations of the aircraft manufacturer.

Another of the important factors to be considered when you are making a skin repair is the stress intensity of the damaged panel. For example, certain skin areas are classified as highly critical, other areas as semicritical, while still other areas may be classified as noncritical. Repairs to damages in highly critical areas must provide 100-percent strength replacement; semicritical areas require 80-percent strength replacement; and noncritical areas require 60-percent strength replacement. When a repair specifies it must provide 60-percent strength replacement, this indicates the amount of repair strength necessary to maintain a margin of safety on skin areas. The 60-percent stress intensity repair is specified when production methods

and stiffening requirements have resulted in an overstrength skin with a high margin of safety. This repair provides strength and stiffness equivalent to specific design requirements rather than the original structure of the material. The 100-percent stress intensity repair makes the strength of the repaired skin equal to or greater than the original undamaged skin. This type of skin usually has a low margin of safety.

Lap Patches

A lap patch is an external patch that has the edges of the patch and the skin overlapping each other. The overlapping portion of the patch is riveted to the skin. On some aircraft, lap patches are permitted in certain areas, but only where aerodynamic smoothness is not important. In areas where it is permitted, the lap patch may be used in repairing cracks as well as small holes.

To repair cracks, you should always drill a small hole (normally called stop drilling) in each end of the crack before applying the patch. Normally, you will use a No. 30 or No. 40 drill bit for this task. This prevents the concentration of stresses at the apex of the crack and distributes the stresses around the circumference of the hole. The patch must be large enough to install the required number of rivets as determined from the rivet schedule indicated for the gauge material in the area that is damaged. See figure 4-58. The recommended patch may be cut in a circular, square, rectangular, or diamond shape. The edges are normally chamfered (beveled) to an angle of 45 degrees for approximately one-half its thickness.

The rivet pattern is laid out on the patch by using the proper edge distance and spacing. The installation position of each rivet is marked with a center punch. The impression in the material made with the center punch helps to keep the drill from slipping away from the hole being drilled. See figure 4-59. Drill only a

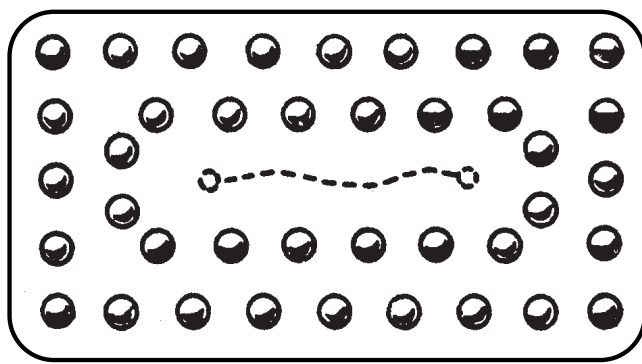

AMF04058

Figure 4-58.—Lap patch for repairing a crack in stressed skin.

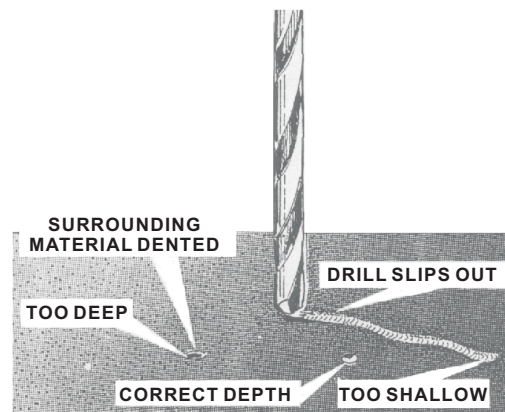

AMF04059

Figure 4-59.—Drilling holed for rivets.

minimum number of rivet holes in the patch; normally four will suffice at an angle of 90 degrees to each other. Position the patch over the surface being repaired, and ensure that the correct edge distances are being maintained. Drill four holes in the surface being repaired, using the predrilled holes in the patch as a pattern for alignment. As each hole is drilled, using the proper temporary fasteners, secure the patch in place. When the patch is temporarily secured, drill the remaining rivet holes through the patch and the surface being repaired. Remove the patch and deburr all rivet holes with a deburring tool or a large drill bit. Prime the repair materials with the proper corrosion-preventive material before the riveting operation. Secure the patch in position with temporary fasteners to maintain alignment during riveting.

Holes may be repaired in either stressed or nonstressed skin that is less than three-sixteenths of an inch in diameter by filling with a rivet. Drill the hole and install the proper size rivet to fill the hole. For holes three-sixteenths of an inch and larger, you should consult the applicable structural repair manual for the necessary repair information. The damaged area is removed by cutting and trimming the hole to a circular, square, rectangular, or diamond shape. The corners of the hole should be rounded to a minimum of one-fourth of an inch in radius. The lap patch is fabricated and installed in the same manner as previously explained for repairing cracks.

Flush Patches

A flush patch consists of a filler patch that is flush with the skin after it is inserted. It is backed up and riveted to a reinforcement plate that, in turn, is riveted to the inside of the skin. This reinforcement plate is usually referred to on some repair diagrams as the doubler or the backup plate. On some high-performance aircraft, only the flush patch is permitted in making skin repairs.

Flush patches should be used where aerodynamic smoothness is required. The type of flush patch used depends on the location of the damaged area. One type is clear of internal structures, and the other is not. Like all types of repairs, you must consult the applicable structural repair manual for the necessary repair information. The repairs discussed next are typical of most repairs.

FLUSH PATCH CLEAR OF INTERNAL STRUCTURES.—In areas that are clear of internal structure, the repair is relatively simple to make. This is

especially true where there is an access door or plate through which the rivets can be bucked. In inaccessible areas, the flush patch may be made by substituting blind rivets for standard rivets, where permissible, and devising a means of inserting the doubler through the opening.

One method, shown in figure 4-60, has a doubler that has been split. To insert the doubler, slip the split edge under the skin and twist the doubler until it slides in place under the skin. The screw in the center of the doubler is temporarily installed to serve as a handle for inserting the doubler through the hole. This type of patch is normally recommended for holes up to 1 1/2 inches in diameter. In holes larger than 1 1/2 inches,

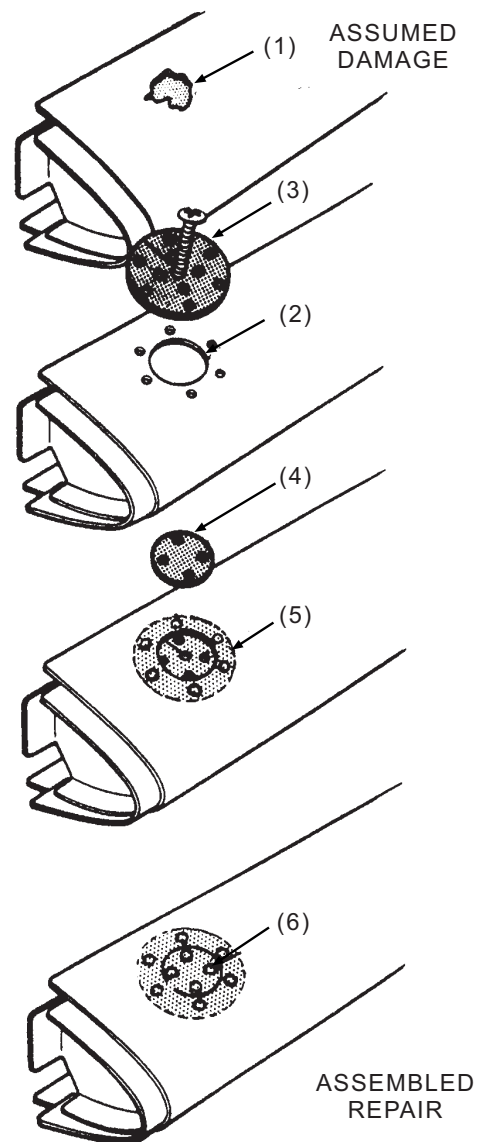

AMF04060

Figure 4-60.—Repair of small holes in skin with flush patch.

trim a hole to a rectangular or elliptical shape and round the corners to a generous radius. See figure 4-61.

On larger repair areas, it is usually possible to buck the doubler rivets by inserting and holding the bucking bar through the center of the doubler. The filler is then riveted in place with blind fasteners. When blind rivets are used as substitutes for solid rivets, the structural repair manual normally specifies the next larger size. The proper edge distances for the substitute fasteners must be maintained.

NOTE: Edge distance was discussed earlier. In all flush patches, the filler should be of the same gauge and material as the original skin. The doubler, generally, should be of the same material and one gauge heavier than the skin. Structural repair manuals will specify the allowable substitution of materials. This can be in the form of a Note on the repair diagram.

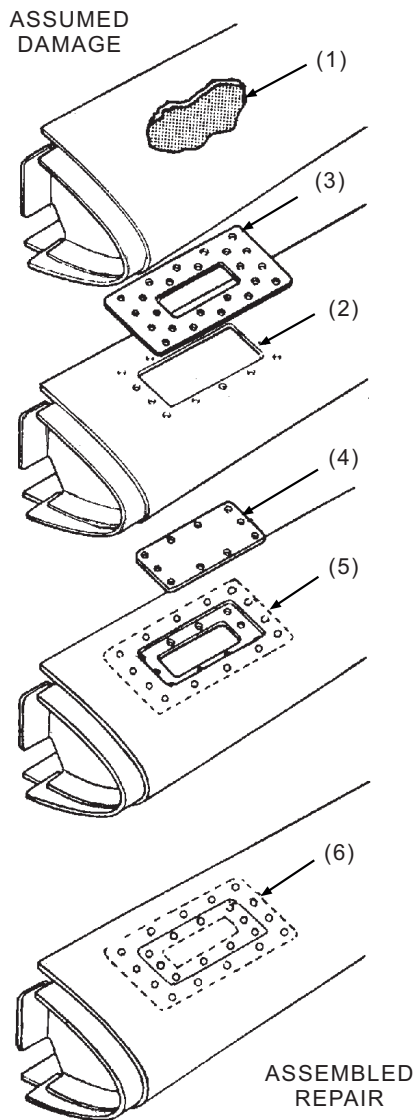

AMf04061

Figure 4-61.—Flush rectangular patch.

When you are laying out the size of the doubler, the length should exceed the width. This enables the doubler to be slipped in through the skin and positioned for installation. This eliminates the splitting and manipulation of the patch required in installing doublers of square and round flush patch repairs.

The filler is fabricated slightly less than the dimensions of the hole being repaired. Generally, the maximum clearance between the skin and the filler is one thirty-second of an inch. This will allow a 1/64-inch clearance on each end of the filler and eliminate any possibility of stress developing from contact between the two parts.

The doubler is fabricated larger than the hole being repaired to allow for the specified number of rivets required to attach the doubler to the skin being repaired. The doubler, filler, and attaching skin rivet pattern may

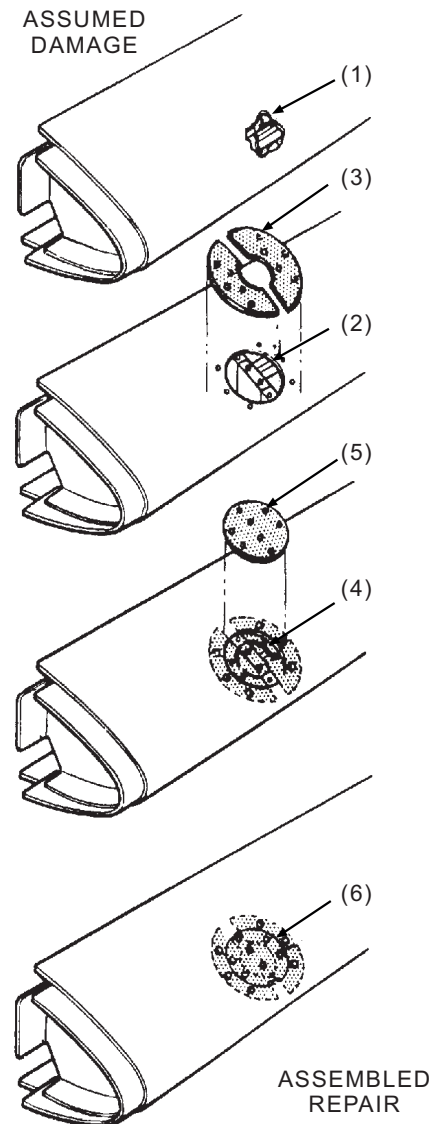

AMf04062

Figure 4-62.—Flush patch over internal structure.

be laid out, drilled, and deburred in the identical manner as described for a lap patch. After the required corrosion-preventive materials have been applied, the doubler is positioned in the structure's interior and secured with temporary fasteners. Inspect the rivet holes for proper alignment, and rivet the doubler in place with solid rivets. The filler can then be riveted in place with blind fasteners.

NOTE: If the flush repair is in an open skin area, the filler may be riveted to the doubler prior to installing the doubler.

FLUSH PATCH OVER INTERNAL STRUCTURES.—Fabricating a flush patch over internal structures may become difficult. In some instances, it may be done simply with a split doubler and a filler, as shown in figure 4-62. Frequently a split doubler, filler strips, and filler are used in the repair. The filler strip is used as a spacer if a structural component under the skin has been damaged. In all cases, the existing

structure's rivet holes should be used when the rivet pattern is laid out. The flush patch over internal structure is installed with the same methods as described for a flush patch clear of internal structure, except for modification of the doubler.

CHEM-MILLED SKIN REPAIR.—On some aircraft the fuselage skin is Chem-Milled or machine tapered and highly stressed. Figure 4-63 shows a Chem-Milled skin repair in a pressurized fuselage section. The skin consists of a shim, a doubler, and a filler. The damage area is trimmed and the inside corners are filed to one-fourth of an inch in radius. The replaced metal and rivets or other fasteners must be equal to or stronger than the original. The structural repair manual should be consulted for fastener spacing, edge distance, and repair procedure. During final assembly of the repair, the fabricated parts should be bonded together with an adhesive to ensure pressurization is maintained.

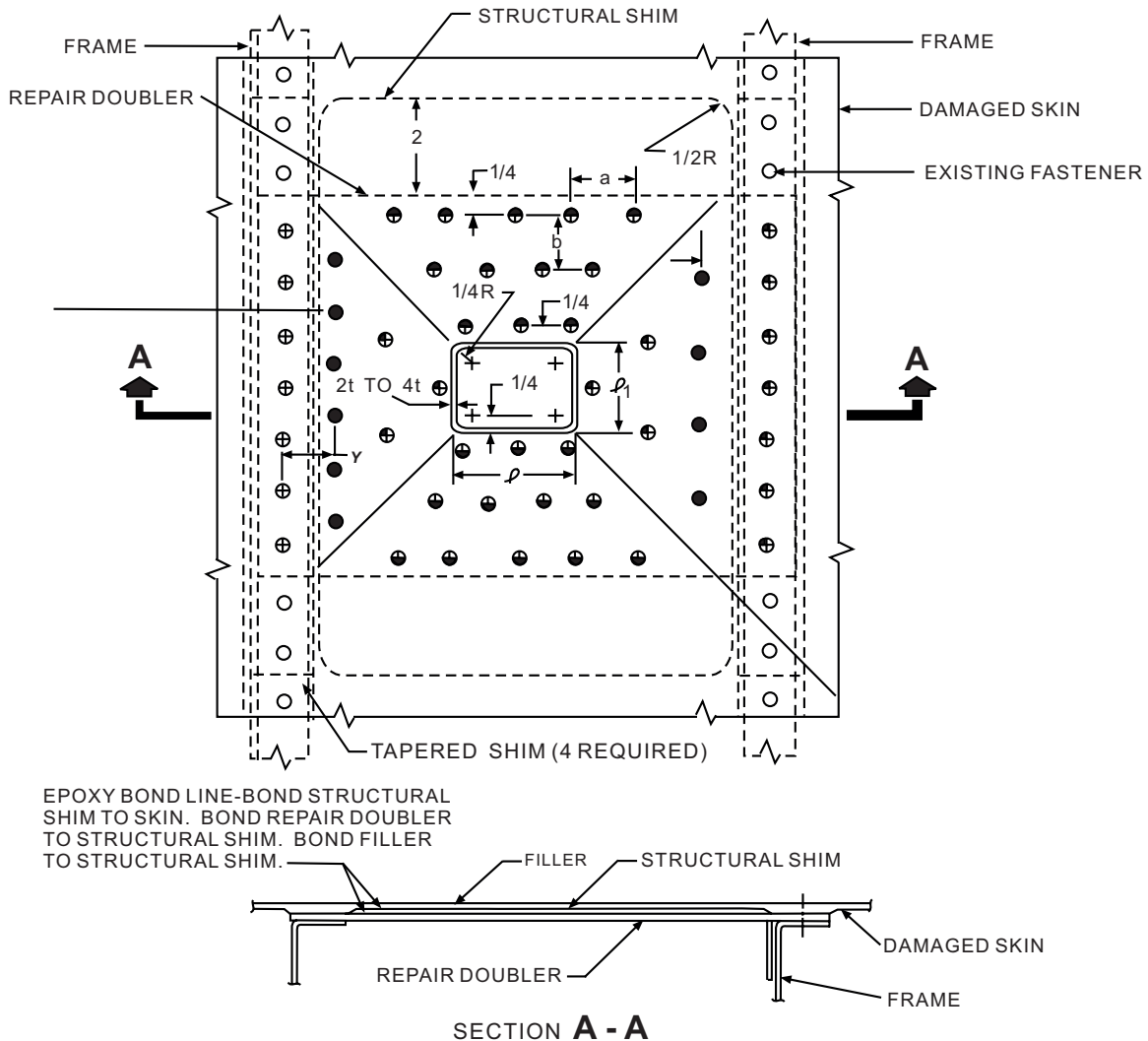

Figure 4-63.—Chem-Milled skin repair (fuselage pressurized).

AMf04063

FLUSH ACCESS DOOR.—A flush access door installation, as shown in figure 4-64, is sometimes permitted. It is installed to make repair to the internal structure easier and to permit repair of damage to the skin in certain areas. The flush access door consists of a doubler and a stressed cover plate. The cover plate is normally fabricated from material identical to the skin. A single row of nut plates is riveted to the doubler. The doubler is then riveted to the interior side of the skin with two rows of rivets, staggered as shown in figure 4-64. The cover plate is attached to the doubler with machine screws. When an access door is permitted and installed over the internal structure, screws should be installed through the cover plate into the internal structural member wherever possible.

SKIN REPLACEMENT.—Sometimes damage to the metal skin is so extensive that an entire panel must be replaced. Also, an excessive number of patches or minor repairs to a section may require the replacement of the entire panel.

As in all other forms of repairs, the first step is to inspect the damaged area thoroughly to determine the

extent of the damage. Inspect the internal structure for damage or signs of strain. Members that are bent, fractured, or wrinkled must be replaced or repaired. They may be sheared considerably without visible evidence of such a condition. You should drill out rivets at various points in the damaged area and examine them for signs of shear failure.

During the inspection, note carefully all unusual riveting problems or conditions that render riveting difficult or make rivet replacement impossible. Any fixtures that will hinder riveting and prevent the use of straight bucking bars will be apparent in a thorough inspection. There will also be places where flanges or reinforcing members, intersection of stringers, longerons, formers, frames, or rings make the bucking of rivets very difficult. This problem can be solved by designing and making bucking bars to suit these particular situations.

You must take care to avoid mutilating the damaged skin in the removal process. In some cases, it can be used as a template for the layout and the drilling of holes in the new piece of skin.

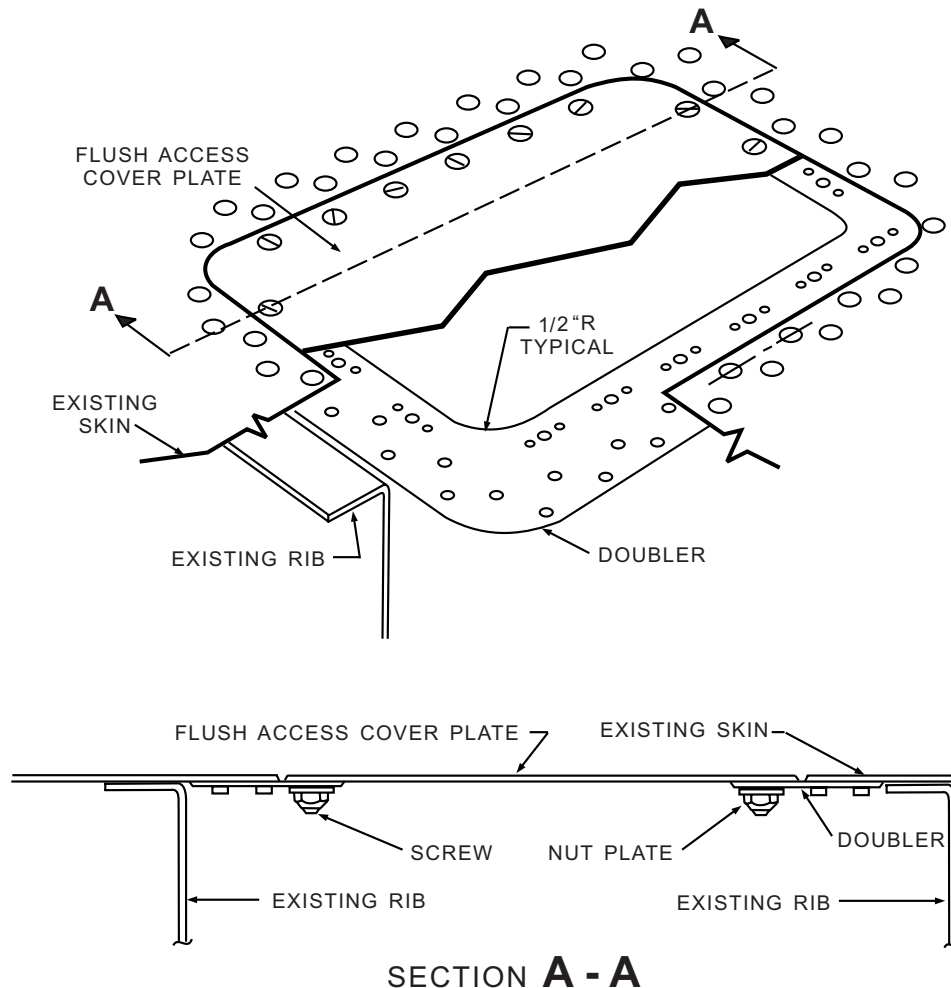

AMf04064

Figure 4-64.—Flush access door installation.

The rivet holes in stringers, longerons, bulkheads, formers, frames, rings, and other internal members must be kept in the best condition possible. If any of these members are loosened by the removal of rivets, their location should be marked so they can be returned to their original position.

You should refer to the applicable repair material chart in the aircraft structural repair manual for the gauge and alloy of material to be used for the replacement panel. The size and shape of the panel may be determined in either of two ways. The dimensions can be measured during the inspection, or the old skin can be used as a template for the layout of the sheet and the location of the holes. The second method is preferable and more accurate. Regardless of the method used, the new sheet must be large enough to replace the damaged area, and it may be cut with an allowance of 1 to 2 inches of material outside the rivet holes.

If the old sheet is not too badly damaged, it should be flattened and used as a template. The new sheet, having been cut approximately 1 inch larger than the old, should then be drilled near the center of the sheet by using the holes in the old sheet as a guide. The two sheets are then fastened together with sheet metal fasteners. The use of sheet metal screws is not recommended since they injure the edge of the rivet holes. The drilling should proceed from the center to the outside of the sheet. You should insert sheet metal fasteners at frequent intervals.

If it is impossible to use the old sheet as a template, the holes in the new sheet should be drilled from the inside of the structure. Use the holes in the reinforcing members as guides, and insert fasteners at frequent intervals. This process is called backdrilling. Before

you place the new sheet on the framework to drill the holes, make certain that the reinforcing members are aligned and flush at the points at which they intersect; otherwise, the holes in the new sheets will not be accurately aligned. For the same reason, the new sheet should have the same contour as the old before drilling the rivet holes.

To duplicate holes from reinforcing members to the skin, you must exercise extreme care or both frame and skin will be ruined. Since most bulkheads, ribs, and stringers depend on the skin for some of their rigidity, they can easily be forced out of alignment in the drilling process. The skin must be held firmly against the framework, or the pressure from the drilling will force it away from the frame and cause the holes to be out of alignment. This may be overcome by placing a block of wood against the skin and holding it firmly while the drilling progresses. Also, make sure that the drill is held at a 90-degree angle to the skin at all times, or the holes will be elongated and out of alignment. When you drill through anchor nuts, a smaller pilot drill should be used first. You must use care so as not to damage the anchor nut threads. The pilot holes are then enlarged to the proper size.

It may be necessary to use an angle attachment or flexible shaft drill in places where it is impossible to insert a straight drill. In case neither type can be inserted, the new section should be marked carefully with a soft pencil through the holes in the old section. Another method of marking the location of the new holes is to use a transfer or prick punch, as shown in figure 4-65. Center the punch in the old hole, and then tap the punch lightly with a hammer. The result should be a mark that will serve to locate the hole in the new sheet.

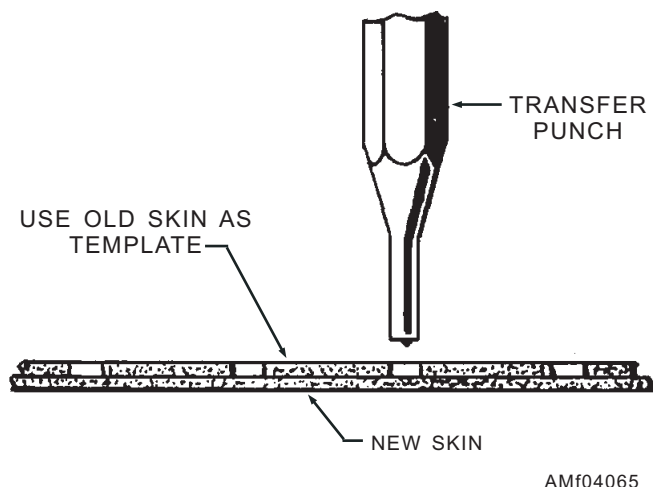

AMf04065

Figure 4-65.—Transferring rivet holes.

Still another way to locate the rivet holes without a template is to use a hole finder similar to the one shown in figure 4-66.

After all the holes have been drilled, the temporary fasteners are taken out and the sheet is removed from the framework. The burrs left by drilling must be removed from both sides of all holes in the skin, the stringers, and the rib flanges. Burring may be accomplished with a few light turns of a deburring tool or drill bit. In this way, particles of metal left around the edges of the drilled holes are eliminated. If they were not removed, the joint would not be tight and rivets might expand, or flash, between the parts being riveted.

Internal

The repair of internal structures concerns the repair or replacement of extruded parts used as stringers, webs used as bulkheads, and formed parts, such as ribs and formers.

After the damage has been inspected and classified, the next consideration is to plan the repair so that it may be assembled in the proper sequence. Before the removal, repair, or replacement of a structural member is undertaken, the adjacent structural members of the aircraft must be supported so that proper alignment is maintained throughout the operation.

STRINGERS.—A stringer is a spanwise structural member designed to stiffen the skin and aid in maintaining the contour of the structure. Stringers also transfer stresses from the skin to the bulkheads and ribs to which they are attached. Stringers are not continuous throughout the structure as are longerons and are not subject to as much stress. Stringers are made from both extruded and rolled sections, and are usually in the form of C-channels, angles, or hat sections.

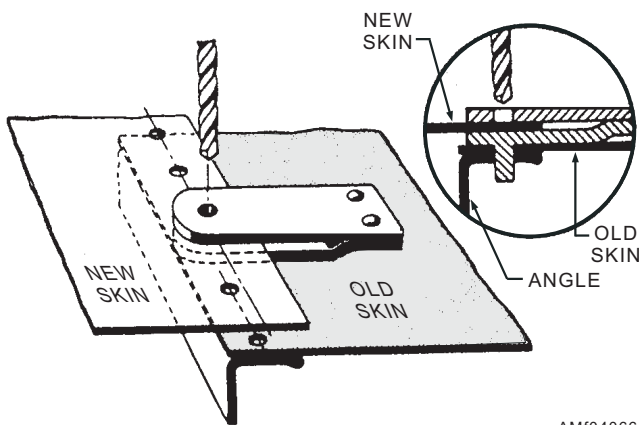

AMf04066

Figure 4-66.—Using a hole finder.

Patching is one method used in repairing a damaged stringer (fig. 4-67). The repair consists of a reinforcement splice and a filler splice. The reinforcement splice should be long enough to extend a minimum of four times the width of the leg of the stringer on each side of the damaged area. The cross-sectional area of the reinforcement splice must be equal to or greater than the stringer itself. The damage is cleaned to a smooth contour with corner radii, and a filler of the proper thickness is prepared to fit in the cleaned area. If possible, you should always make both ends of the cutout midway between two rivets so that the existing rivet pattern can be maintained in the repair. Cut the filler splice one thirty-second of an inch shorter in length than the cutout section. This will allow a 1/64-inch clearance stringer between each end of the filler splice and the stub ends of the stringer. This eliminates the possibility of stress developing from contact between the two parts.

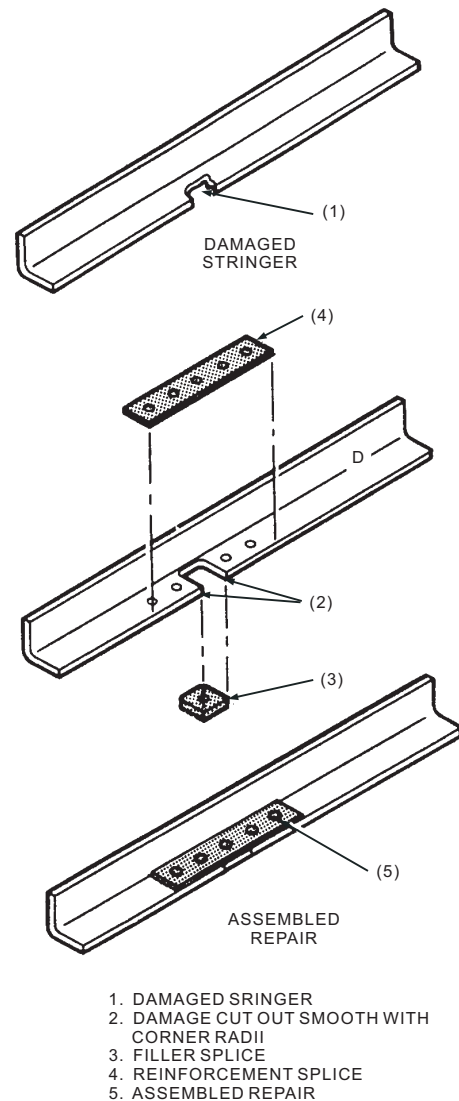

1. DAMAGED STRINGER
2. DAMAGE CUT OUT SMOOTH WITH CORNER RADII
3. FILLER SPLICE
4. REINFORCEMENT SPLICE
5. ASSEMBLED REPAIR

AMf04067

Figure 4-67.—Stringer repair by patching.

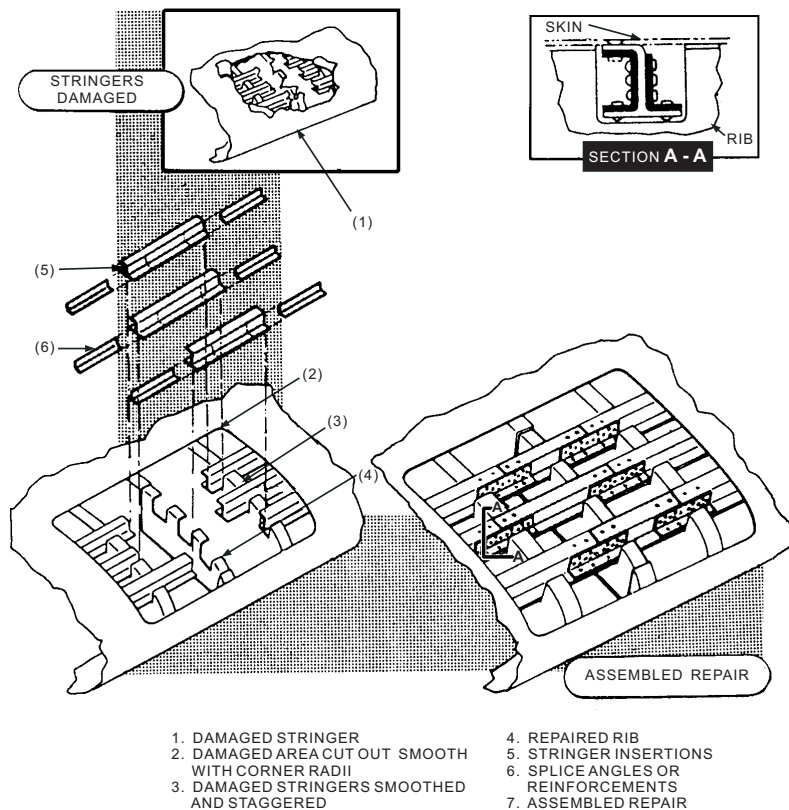

1. DAMAGED STRINGER
2. DAMAGED AREA CUT OUT SMOOTH WITH CORNER RADII
3. DAMAGED STRINGERS SMOOTHED AND STAGGERED
4. REPAIRED RIB
5. STRINGER INSERTIONS
6. SPLICE ANGLES OR REINFORCEMENTS
7. ASSEMBLED REPAIR

Amf04068

Figure 4-68.—Stringer repair by insertion.

NOTE: The above repair is permissible when the damage does not exceed two-thirds of the width of one leg of the stringer and is not over 12 inches in length. When the damage is of such length that a single reinforcement splice would involve an excessive amount of material and work, a repair by insertion should be made. See figure 4-68.

SPARS.—Spars (also called beams) are the main spanwise members of the wing, stabilizers, and other airfoils. They may run the entire length of the airfoil. Spars are designed primarily to take bending loads imposed on the wing or other airfoil.

The most common type of spar construction consists of extruded capstrips, a sheet metal web or plate, and a vertical angle stiffener. Since spars are very highly stressed members, their repair may not be permitted; and if permitted, must be made in strict accordance with instructions given in the structural repair manual, using the best possible workmanship. Figure 4-69 shows a spar web repair by insertion.

RIBS.—Ribs are the principal chordwise structural members in the wings, stabilizers, and other airfoils. Ribs serve as formers for the airfoil. They give it shape and rigidity and also serve to transmit stresses from the skin to the spars. They are designed to resist both compression and shear loads.

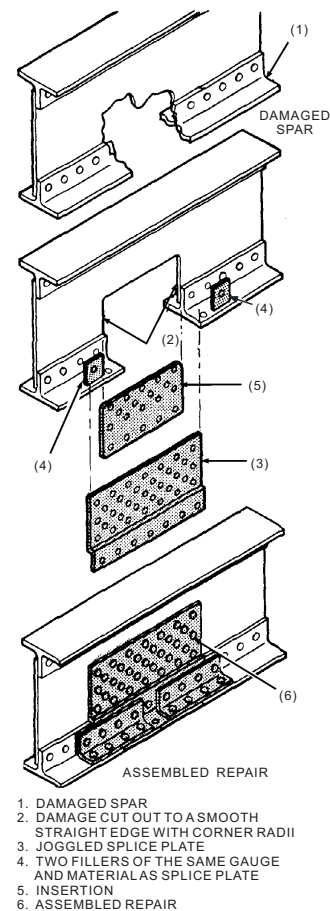

1. DAMAGED SPAR
2. DAMAGE CUT OUT TO A SMOOTH STRAIGHT EDGE WITH CORNER RADII
3. JOGGLED SPLICE PLATE
4. TWO FILLERS OF THE SAME GAUGE AND MATERIAL AS SPLICE PLATE
5. INSERTION
6. ASSEMBLED REPAIR

AMf04069

Figure 4-69.—Spar repair by insertion.

There are three general types of rib construction, as shown in figure 4-70. The reinforced rib and the truss rib are both relatively heavy as compared to the former rib. They are located only at points where the greatest stresses are imposed. Former ribs are located at frequent intervals throughout the airfoil.

The reinforced rib is similar in construction to that of spars. It consists of upper and lower capstrips joined by a web plate. The web is reinforced between the capstrips by vertical and diagonal angles. The reinforced rib is more widely used than the truss rib.

The truss rib consists of capstrips reinforced solely by vertical and diagonal crossmembers. It is used in the wings of some of the Navy's larger aircraft.

Former ribs are made of formed sheet metal and are very light in weight. The bent-up portion of a former rib is correctly referred to as the flange. The vertical portion is called the web. The web is generally constructed with lightening holes, with beads formed between the holes. The lightening holes lessen the weight of the rib without decreasing the strength. Rigidity of lightening hole areas is accomplished by flanging the edges of the lightening holes. The beads stiffen the web portion of the rib. Rib repair by patching is shown in figure 4-71.

BULKHEADS.—Any major vertical structural member of a semimonocoque fuselage, hull, or float may be considered a bulkhead. Bulkheads serve to maintain the required external contour at the station

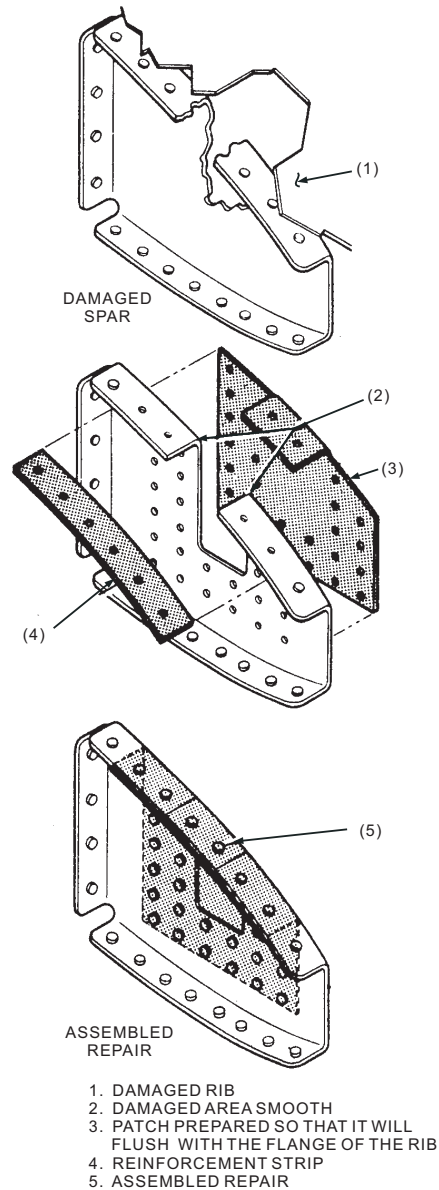

Figure 4-71.—Rib repair by patching.

where they are located. They also give rigidity and strength to the structure.

Bulkhead construction is similar to that used for wing ribs. It consists of a web reinforced by angle stiffeners. The web is attached to the skin by formed flanges or extruded angles, which serve as capstrips. Non-watertight bulkheads may have lightening holes, and most bulkheads are cut out to give clearance for stringers. The stringers are usually attached to the bulkhead by angle clips.

The repair of the web and formed flange of a bulkhead is similar to that used for the rib web and flange repair; however, the structural repair manual must be consulted for specific information on the repair of a particular bulkhead.

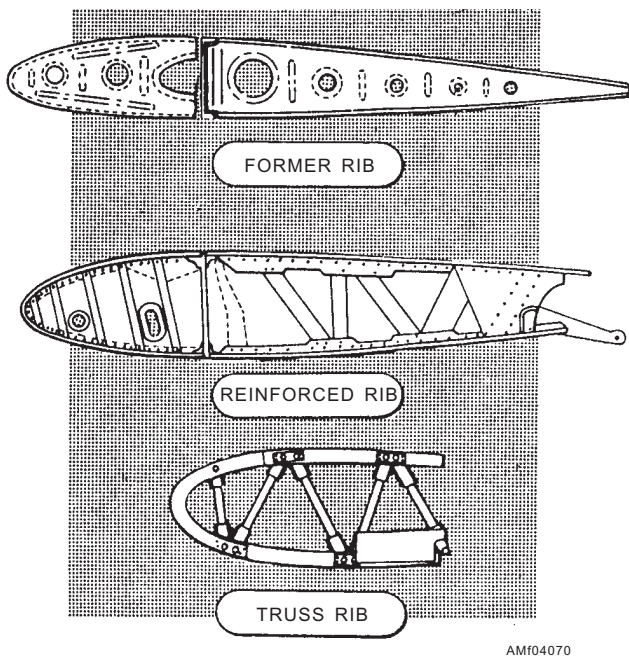

Figure 4-70.—Types of ribs.

When damage to the web is a crack, dent, or small hole, it may be repaired in the same manner as fully stressed skin. Buckled webs may be repaired by riveting an angle reinforcement over the buckled area, provided the bulkhead is not otherwise distorted. Sheet metal used for repairs near a flanged lightning hole should be formed with a 90-degree flange to provide additional stiffening.

LONGERONS.—Most aircraft fuselages are constructed in sections and are of the semimonocoque design. A longeron is a fore-and-aft member of the fuselage or nacelle and is usually continuous across a number of points of support, such as frames and bulkheads. The longerons, along with the stringers, are the major load-carrying members and stiffeners. Figure 4-72 shows the location of the major members of a semimonocoque design forward fuselage. In case it becomes necessary to repair a longeron, review the section on stringer repair and follow the same procedure.

- Q4-34. *After cleaning the damaged area of an aircraft, what is the next step in the repair process?*
- Q4-35. *What kind of damage can turn into permanent damage if not properly treated?*
- Q4-36. *Damage caused by tools, bolts, rivets, and nuts left adrift is known as what type of damage?*

- Q4-37. *What type of damage can be identified by loosened, sheared, or popped rivets?*
- Q4-38. *When inspecting an area for damage, you should always check rivet and bolt holes for what condition?*
- Q4-39. *What type of test should always be performed on metal after a fire has occurred?*
- Q4-40. *If you suspect a crack exist, what type of inspection should you perform?*
- Q4-41. *Small cracks that can be stop-drilled, dents, scratches, or other minor damage that does not require major repair or replacement and does not restrict flight status is defined as what type of damage?*
- Q4-42. *Damage that cannot be repaired by any practical means is defined as what type of damage?*
- Q4-43. *The major requirement on making a repair is to ensure you duplicate what condition?*
- Q4-44. *The process of interpreting and transcribing of information from blueprints, drawings, and written instructions for the metal to be made into aircraft parts is known by what term?*
- Q4-45. *If you are required to fabricate multiple parts of the same dimensions, what can you use to ensure a higher degree of uniformity and speed production?*

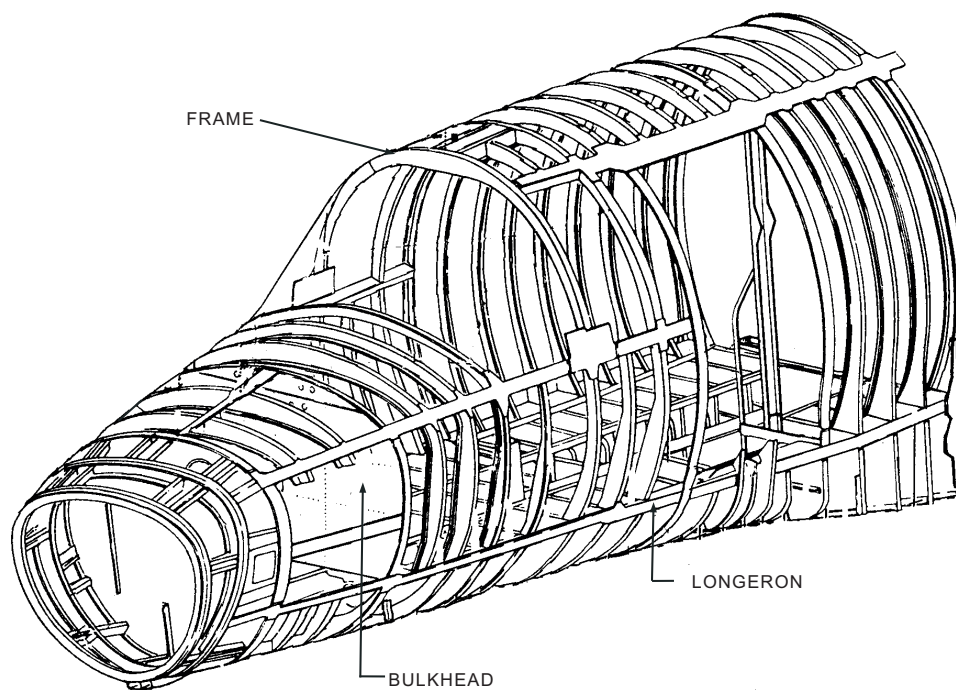

Figure 4-72.—Forward fuselage (semimonocoque).

AM104072

- Q4-46. *What can you use to maintain aerodynamic smoothness when repairing negligible damage, steps, and gaps?*
- Q4-47. *What step must you take before applying a lap patch over a crack?*
- Q4-48. *As a general rule, when you make a flush patch, what is the maximum clearance between the skin and the filler?*
- Q4-49. *When making a repair over an internal structure, what rivet pattern must you use?*
- Q4-50. *The main spanwise members designed primarily to take bending loads on the wing or other airfoils are known as what type of members?*
- Q4-51. *What structural members are designed to give the airfoil shape and rigidity?*
- Q4-52. *What structural member runs fore-and-aft along the length of the fuselage and is continuous across frames and bulkheads?*

AIRFRAME FUEL SYSTEM

LEARNING OBJECTIVE: Recognize the different types of aircraft fuel cells. Identify repair procedures for integral fuel cells.

Airframe fuel system maintenance is the responsibility of more than one work center. For instance, ADs remove and install bladder and self-sealing fuel cells. Personnel of the AM rating perform the repairs on integral tanks. Personnel from the AO rating usually help in the installation and removal of external tanks (drop tanks).

To meet the particular needs of the various types of aircraft, fuel tanks vary in size, shape, construction, and location. Sometimes a fuel tank is an integral part of a wing. Most often fuel tanks are separate units, configured to the aircraft design and mission.

FUEL TANK CONSTRUCTION

The material selected for the construction of a particular fuel tank depends upon the type of aircraft and its mission. Fuel tanks and the fuel system in general are made of materials that will not react chemically with any fuels. Fuel tanks that are an integral part of the wing are of the same material as the wing. The tank's seams are sealed with fuelproof sealing compound. Other fuel tanks may be synthetic

rubber, self-sealing cells, or bladder-type cells that fit into cavities in the wing or fuselage of the aircraft.

Fuel tanks must have facilities for the inspection and repair of the tank. This requirement is met by installing access panels in the fuselage and wings. Fuel tanks must be equipped with sump and drains to collect sediment and water. The construction of the tank must be such that any hazardous quantity of water in the tank will drain to the sump, so the water can be drained from the fuel tank.

Self-Sealing Fuel Cells

A self-sealing cell is a fuel container that automatically seals small holes or damage caused during combat operations. A self-sealing cell is not bulletproof, merely puncture sealing. As shown in figure 4-73, the bullet penetrates the outside wall of the cell, and the sticky, elastic sealing material surrounds the bullet. As the bullet passes through the cell wall into the cell, the sealant springs together quickly and closes the hole. Now some of the fuel in the tank comes in contact with the sealant and makes it swell, completing the seal. In this application, the natural stickiness of rubber and the basic qualities of rubber and petroleum seal the hole. This sealing action reduces the fire hazard brought about by leaking fuel. It keeps the aircraft's fuel intact so the aircraft may continue operating and return to its base.

The most commonly used types of self-sealing fuel cells are the standard construction type and the type that uses a bladder along with the self-sealing cell. Of the two, the standard construction cell is used the most. It is a semiflexible cell, made up of numerous plies of material.

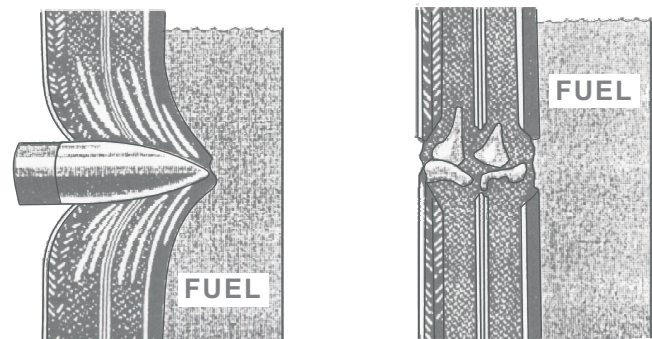

Figure 4-73.—Bullet-sealing action.

The combination bladder and self-sealing cell is made up of two parts. One part is a bladder-type cell, and the other part is identical to the standard construction cell. It is designed to self-seal holes or damage in the bottom and the lower portions of the side areas. The bladder part of the cell (nonself-sealing) is usually restricted to the upper portion. This type of cell is also semiflexible.

SELF-SEALING CELL (STANDARD CONSTRUCTION).—There are four primary layers of materials used in the construction of a self-sealing cell. These layers are the inner liner, nylon fuel barrier, sealant, and retainer. All self-sealing fuel cells now in service contain these four primary layers of materials. If additional plies are used in the construction of the cell, they will be related to one of the primary plies.

The inner liner material is the material used inside the cell. It is constructed of Buna N synthetic rubber. Its purpose is to contain the fuel and prevent it from coming in contact with the sealant. This will prevent premature swelling or deterioration of the sealant.

Buna rubber is an artificial substitute for crude or natural rubber. It is produced from butadiene and sodium, and is made in two types, Buna S and Buna N. The Buna S is the most common type of synthetic rubber. It is unsuitable for use as inner liner material in fuel cells. It causes the petroleum fuels used in aircraft to swell and eventually dissolve. The Buna N is not affected by petroleum fuels, making it ideal for this application. However, the Buna N is slightly porous, making it necessary to use a nylon barrier to prevent the fuel from contacting the sealant.

The nylon fuel barrier is an unbroken film of nylon. The purpose of the nylon fuel barrier is to prevent the fuel from diffusing farther into the cell. The nylon is brushed, swabbed, or sprayed in three or four hot coats to the outer surface of the inner liner during construction.

The sealant material is the next material used in fuel cell construction. It remains dormant in the fuel cell until the cell is ruptured or penetrated by a projectile. It is the function of the sealant to seal the ruptured area. This will keep the fuel from flowing through to the exterior of the fuel cell (fig. 4-73.)

The mechanical reaction results because rubber, both natural and synthetic, will "give" under the shock of impact. This will limit damage to a small hole in the fuel cell. The fuel cell materials will allow the projectile to enter or leave the cell, and then the materials will

return to their original position. This mechanical reaction is almost instantaneous.

The chemical reaction takes place as soon as fuel vapors penetrate through the inner liner material and reach the sealant. The sealant, upon contact with fuel vapors, will extend or swell to several times its normal size. This effectively closes the rupture and prevents the fuel from escaping. The sealant is made from natural gum rubber.

The retainer material is the next material used in fuel cell construction. The purpose of the retainer is to provide strength and support. It also increases the efficiency of the mechanical action by returning the fuel cell to its original shape when punctured. It is made of cotton or nylon cord fabric impregnated with Buna N rubber.

SELF-SEALING CELL (NONSTANDARD CONSTRUCTION).—One variation from the standard construction is the self-sealing fuel cell, shown in figure 4-74. It has four primary layers—an inner liner, a nylon fuel barrier, two sealant plies, and three retainer plies.

The cords in the first retainer ply run lengthwise of the cell. The cords in the second retainer run at a 45-degree angle to the first. The cords in the third retainer run at a 90-degree angle to the second. The outside is coated with Buna-Vinylite lacquer to protect the cell from spilled fuel and weathering.

Baffles and internal bulkheads are used inside the cell to help retain the shape of the cell and prevent sloshing of the fuel. They are constructed of square woven fabric impregnated with Buna N rubber.

Flapper valves are fitted to some baffles to control the direction of fuel flow between compartments or interconnecting cells. They are constructed of Micarta, Bakelite, or aluminum.

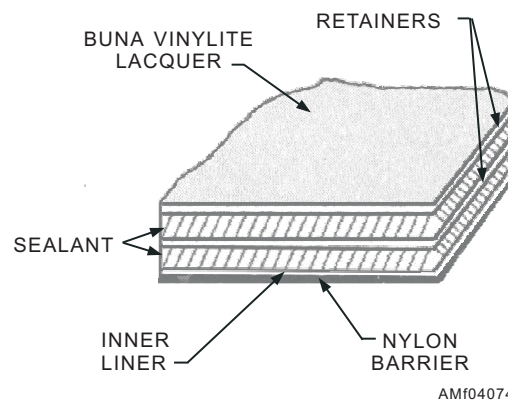

AM104074

Figure 4-74.—Self-sealing fuel cell (standard construction).

These plies, baffles, internal bulkheads, and flapper valves with the necessary fittings and combinations make up a typical self-sealing fuel cell.

Bladder-Type Fuel Cells

A nonself-sealing fuel cell is commonly called a bladder cell. It is a fuel container that does not self-seal holes or punctures. The advantage of using a bladder fuel cell results from the saving in weight. Some of the other advantages are the simplicity of repair techniques and the reduced procurement costs over self-sealing fuel cells.

Bladder-type cells are usually made of very thin material to give minimum possible weight. They require 100-percent support from a smooth cavity. The cell is made slightly larger than the cavity of the aircraft for better weight and distribution throughout the aircraft's fuel cavity structure.

The thinner wall construction increases the fuel capacity over the self-sealing cells, thus increasing the range of the aircraft. Many of our aircraft that were formerly equipped with self-sealing cells have been changed to bladder-type cells.

There are two types of bladder fuel cells—rubber type and nylon type.

RUBBER-TYPE BLADDER CELLS.—The rubber-type bladder cells are made in the same manner as self-sealing cells. They have a liner, nylon barrier, and a retainer ply. The sealant layers are omitted. All three plies are placed on the building form as one material in the following order: liner, barrier, and retainer. Figure 4-75 shows this type construction.

The inner liner may consist of Buna N rubber, Buna N coated square-woven fabric (cotton or nylon), or Buna N coated cord fabric. The purpose of the inner liner is to contain the fuel and provide protection for the nylon barrier.

The nylon barrier consists of three to four coats of nylon applied hot by brush, swab, or spray. The purpose of the nylon barrier is to keep fuel from diffusing through the cell wall.

The retainer consists of Buna N coated square-woven fabric (cotton or nylon) or cord fabric. The purpose of the retainer ply or plies is to lend strength to the fuel cell and provide protection for the nylon fuel barrier.

NYLON-TYPE BLADDER CELLS

(PLIOCEL).—Nylon bladder cells differ in construction and material from the Buna N rubber cells. This type of cell may be identified by the trade name "Pliocel" stenciled on the outside of the cell. The Pliocel construction consists of two layers of nylon woven fabric laminated with three layers of transparent nylon film.

The repair of this type of cell must be accomplished by entirely different methods and with different materials. The adhesive and Buna N rubber used to repair the rubber-type bladder cell cannot be used on the nylon-type cell.

INTEGRAL FUEL CELL REPAIR

Integral fuel cells are usually contained in the wing structure; however, in some aircraft integral fuel cells are built into the fuselage. An integral cell is a part of the aircraft structure that has been built in such a manner that after the seams, structural fasteners, and access doors have been properly sealed, it will hold fuel without leaking. This type of construction is usually referred to as a "wet wing."

Usually, the cell area is located between two spars, and is capped on the ends by sealed end ribs. The skin covering may be standard riveted sheet or may be milled from a solid plate of aluminum alloy. The milled skins are usually bolted in place instead of being riveted.

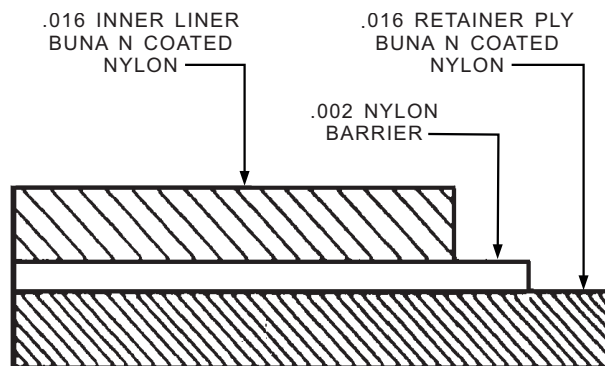

AMf04075

Figure 4-75.—Bladder cell construction.

The wing mating surfaces are built to extremely close tolerances to allow for proper sealing. The sealing of these mating surfaces is attained by using gaskets or sealants, or a combination of both. In most cases, the perimeter of the cell is sealed by using a nonhardening sealant that is injected into a groove machined in one structural member along the mating surface. The attachment screws and bolts are sealed by placing O-ring seals under the heads. Protruding bolt heads are sealed by special seals that consist of an O-ring embedded in a metal washer. Figure 4-76 shows the sealing of integral fuel cell screws and bolts.

Inspection

The inspection of integral fuel cells consists mainly of a check for external leakage around skin joints, rivets, screws, and bolts on every preflight inspection. The fuel cell fittings and connections should also be inspected for evidence of leakage. Fuel cell leaks are classified in the following categories: slow seep, seep, heavy seep, and running leak.

- **SLOW SEEP.** The least severe leak classification is the slow seep. This is a very slow fuel seepage that wets a small area. Over a period of hours, the

wetted area may become larger. A slow seep, when wiped dry, will not reappear in a short period of time.

- **SEEP.** A seep is a fuel leak that reappears in less than an hour (approximately) after it has been wiped dry.

- **HEAVY SEEP.** A heavy seep is a fuel leak that reappears immediately after it has been wiped dry.

- **RUNNING LEAK.** A running leak is a fuel leak that flows steadily.

Most aircraft structural repair manuals do not classify a slow seep or seep in an open area (the surfaces of the aircraft exposed to the airstream) as a flight hazard. A slow seep or seep in an open area need not be repaired before flight if structural integrity exists and there is no danger of an increase in leak intensity during flight. Slow seeps and seeps considered acceptable for flight should be frequently inspected to ensure the leak intensity does not increase prior to flight.

Heavy seeps and running leaks are classified as flight hazards, regardless of their location in the aircraft. Any leak classified as a flight hazard must be corrected before flight.

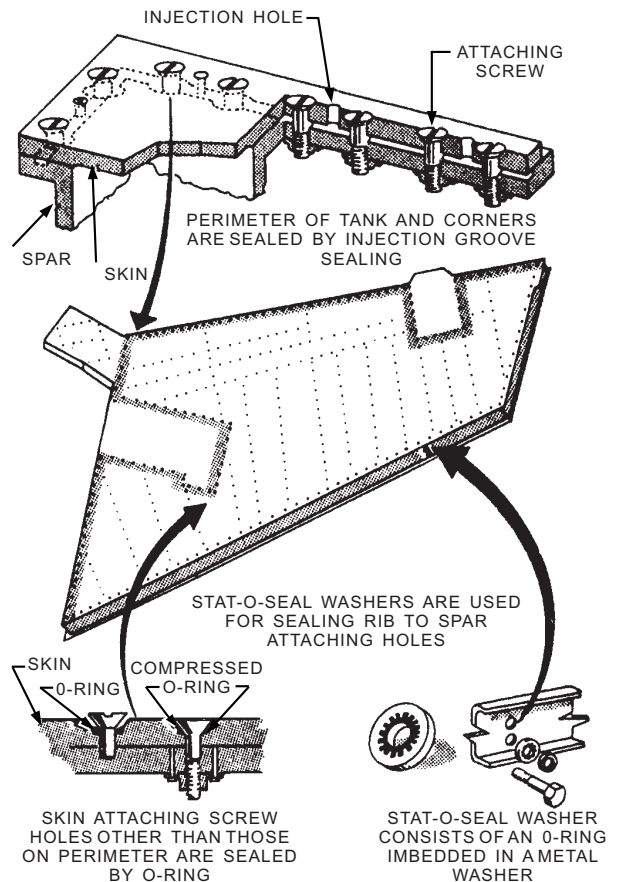

AMf04076

Figure 4-76.—Sealing integral fuel cell screws and bolts.

Maintenance

Leaks are the most common trouble encountered with the integral fuel cells. Slight leaks may sometimes be repaired simply by retorquing (tightening) the bolts or screws on either side of the leak. On others it is often necessary to reseal the injection groove around the perimeter of the wing, and replace the O-rings and washers. Both of these procedures are described in the following text.

RETORQUING.—You should always retorque to stop a fuel stain or seepage before attempting to reseal. The first step in stopping a leak is to retorque the bolts or screws for 6 inches on each side of the leaking area according to the torque values given in the MIM for the different size bolts and screws being used. Standard bolts are used primarily in attaching wing skin and should be torqued from the nut side according to standard torque tables.

REPLACING SEALS.—If, after retorquing, the leak still persists around a bolt and washer seal, replace the seal with a new one. Be sure to install a washer between the bolt head and the seal or leakage will still occur. Also, be sure to torque the bolts according to the torque values listed in the MIM.

If the leak is around an O-ring seal, replace the O-ring. First, loosen the bolt or screw with a steady pressure. Back out the bolt only as far as necessary to remove the O-ring over the head of the bolt or screw. Use petrolatum (Vaseline) if desired. Install a new O-ring and tighten the bolt to the required torque.

The bolt should not be completely removed because of the possibility of cross threading during reinstallation. Cross threading could result in the loss of a structural fastener by stripped threads on the nut plate or by the threads locking and twisting.

REINJECTING SEALANT.—If the leak is at the perimeter of the tank, reinject the sealant. You should use integral fuel tank groove injector compound and fill the groove sealant injector gun.

NOTE: Be sure that the gun is filled in such a manner that no air is trapped in the sealant. Provide air pressure at the inlet of the gun according to the gun manufacturer's instructions.

CAUTION

The ability of the sealant compound to seal depends upon its adhesion to metal. Oils and greases are adhesion breakers and **MUST** be completely removed from all sealing areas, injection tools, and your hands when operating or servicing the injection gun. Some common contaminants are hair oils, body oils, and protective hand creams.

Remove the screws from the injection holes of the area to be sealed, and place the sealant gun nozzle tip into the countersink of the injection hole. See figure 4-77. Special fittings may be attached between the gun tip and the barrel for use in areas of limited accessibility. Hold the gun firmly in position and depress the trigger until a plug of sealing compound at least 1 inch in length flows out of the next adjacent injection screw hole.

CAUTION

It is essential that the groove between injection holes be filled by injection from one direction only. If the sealant is forced into these areas from two directions, it is possible that air bubbles will be trapped in the groove. When injection has been inadvertently made from two directions, sealant should be injected from one side until a plug of sealant 5 inches long has been extruded.

NOTE: The trigger must be released approximately every 30 seconds to allow the gun piston to return before another cycle can begin.

Replace the screw in the hole that has just been injected. Proceed in the same manner on the next adjacent hole (the one from which sealant has protruded) until the area to be resealed is completed. After all injection hole screws have been installed, remove excess sealing compound from the wing by scraping with a wood or plastic blade. The area may be cleaned with solvent.

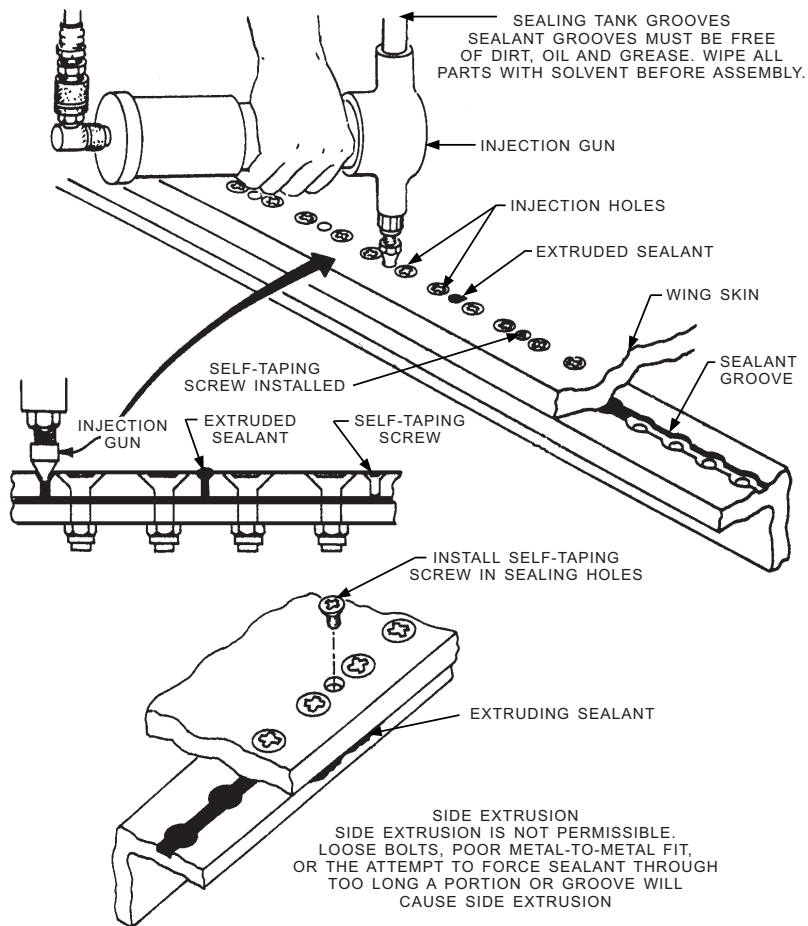

AMf04077

Figure 4-77.—Injection of sealing compound.

CAUTION

Do not use toluene for cleaning any surface with a corrosion-resistant or fuel-resistant coating. Toluene will remove the coating and cause the loss of the coating's protective properties.

If the sealant is exceptionally slow to inject, the tank may be heated to 110°F. Heating can be accomplished by using electric blankets.

CAUTION

Do not heat the tank in excess of 110°F to seal the injection groove as higher temperatures are considered as a fire hazard.

The proper temperatures for sealing are 79° to 84°F. If the tank is exposed to temperatures below 50°F,

the tank must be heated above 70°F before sealing is attempted. This may be accomplished in a heated hangar or by using portable heating units or electric blankets.

NOTE: If the sealing compound does not appear after approximately 4 to 5 minutes, you may assume that the compound is too cold, the groove is plugged, or the surface gap is excessive. In this case, the injection should be discontinued until the discrepancy is remedied.

Testing

When an integral fuel cell has been repaired, it must be pressure checked before it is filled with fuel. Since the pressure testing procedure will vary with different types of aircraft, you should always consult the structural repair manual for the aircraft concerned for the proper procedure. The following equipment is used for pressure testing a system:

- A source of nitrogen and a means of regulating the nitrogen pressure

NOTE: The use of nitrogen for pressure testing the fuel system is recommended since nitrogen is an inert gas, and therefore presents no explosive hazard when it is introduced into a fuel cell containing fuel vapors. A source of dry air is not recommended because it would increase the ratio of oxygen to fuel vapor in the cell, and the possibility of an explosion would be increased.

- Suitable hoses and fittings to connect the testing equipment to fuel the system
- A 0 to 5 psi pressure gauge installed downstream of the nitrogen supply
- Miscellaneous plugs and caps for blocking various lines and fittings

Q4-53. The self-sealing fuel cells now in naval service are made up of what total number of primary layers of material?

Q4-54. What is the main advantage of a bladder-type fuel cell over a self-sealing fuel cell?

Q4-55. When applying the nylon barrier of a rubber-type bladder fuel cell, you should use what method of application?

Q4-56. The milled skins of an integral fuel cell are normally fastened to the aircraft by what means?

Q4-57. A fuel leak that reappears 30 minutes after it is wiped dry is classified as what category of leakage?

Q4-58. What is the first step you should take to stop a fuel leak in an integral fuel cell?

Q4-59. To allow the gun piston to return before another cycle can begin, the trigger of a sealant injector gun must be released approximately how often?

Q4-60. What gas is used to pressure test a repair made on an integral fuel cell?

CHAPTER 5

AIRCRAFT NONMETALLIC REPAIR

INTRODUCTION

This chapter deals with the materials and procedures to be used in the repair of nonmetallic and advanced composite materials used in aircraft construction. The procedures discussed are general in nature. When actually repairing nonmetallic or advanced composite materials, you should refer to the applicable maintenance instruction manual (MIM) and structural repair manual (SRM).

MAINTAINING AND REPAIRING AIRCRAFT NONMETALLIC MATERIALS

LEARNING OBJECTIVE: Recognize the procedures for cleaning, repairing, or replacing aircraft nonmetallic structures and surfaces.

This chapter covers some of the procedures used in the repair or replacement of aircraft nonmetallic structures. Because no one set of rules applies to all aircraft, you should refer to the maintenance instruction manual (MIM) and structural repair manual (SRM) for the materials and procedures for a particular aircraft.

MAINTAINING TRANSPARENT PLASTIC MATERIALS

Because of the many uses of plastic materials in aircraft, optical quality is of great importance. These plastic materials are similar to plate glass in many of their optical characteristics. Ability to locate and identify other aircraft in flight, to land safely at high speeds, to maintain position in formation, and in some cases, to sight guns accurately through plastic enclosures all depend upon the surface cleanliness, clarity, and freedom from distortion of the plastic material. These factors depend entirely upon the amount of care exercised in the handling, fabrication, maintenance, and repair of the material.

Plastics have many advantages over glass for aircraft application, particularly the lightness in weight and ease of fabrication and repairs. They lack the surface hardness of glass and are very easily scratched, with resulting impairment of vision. You must exercise care while servicing all aircraft to avoid scratching or

otherwise damaging the plastic surface. The following general rules apply:

1. Transparent plastic materials should be handled only with clean cotton gloves.
2. The use of harmful liquids, such as cleaning agents, should be avoided.
3. Fabrication, repair, installation, and maintenance instructions must be closely followed.
4. Operations that might tend to scratch or distort the plastic surface must be avoided. You must take care to avoid scratching plastic surfaces with finger rings or other sharp objects.

Just as woods split and metals crack in areas of high, localized stress, plastic materials develop, under similar conditions, small surface fissures called *crazing*. These tiny cracks are approximately perpendicular to the surface, very narrow in width, and usually not over 0.01 inch in depth. These tiny fissures are not only an optical defect, but also a mechanical defect, as there is a separation or parting of material.

If the crazing is in a random pattern, it is usually caused by the action of solvent or solvent vapors. If the crazing is approximately parallel, it is usually caused by directional stress, set up by cold forming, excessive loading, improper installation, improper machining, or a combination of these with the action of solvents or solvent vapors.

Crazing can be caused by improper cleaning, improper installation, improper machining, or cold forming. Once a part has been crazed, neither the optical nor the mechanical defect can be removed permanently; therefore, prevention of crazing is very important.

Cleaning Plastic Surfaces

Masking paper should be left on the plastic as long as possible. When it is necessary to remove the masking paper from the plastic during fabrication or installation, the surface should be remasked as soon as possible. Either replace the original paper or apply masking tape. If the masking paper adhesive deteriorates, making removal of paper difficult, moisten the paper with

aliphatic naphtha, Federal Specification TT-N-95, type II. Plastic so treated should be washed immediately with clear water.

For exterior surfaces, flush with plenty of water, and use your bare hand to gently feel and dislodge any dirt, sand, or mud. Then, wash the plastic with a wetting agent, Specification MIL-D-16791, and clean water.

NOTE: Water containing dirt and abrasive materials may scratch the plastic surface.

A clean, soft cloth, sponge, or chamois may be used to apply the soap and water to the plastic. The cloth, sponge, or chamois should not be used for scrubbing; use the hand method as described for removing dirt or other foreign particles.

Dry with a clean, damp chamois, a soft, clean cloth, or a soft tissue by blotting the surface until dry. Rubbing the surface of the plastic will induce (build up) an electrostatic charge that attracts dust particles to the surface. If the surface does become charged, patting or gently blotting with a damp, clean cloth will remove this charge as well as the dust.

To clean interior plastic surfaces, dust the surface lightly with a soft cloth. Do not wipe the surface with a dry cloth. Next, wipe carefully with a soft, damp cloth or sponge. Keep the cloth or sponge free from grit by rinsing it frequently in clean water.

Cleaning and polishing compound, Specification P-P-560, may be used to remove grease and oil. Apply the compound with a soft cloth, rub in a circular motion until clean, and polish with another soft cloth.

Removing Scratches From Plastic Surfaces

You may be required to remove and install canopies, escape hatches, and other aircraft structures that contain plastic sections. The finish of the plastic must be protected. Plastic is very soft as compared to other aircraft structural materials. The surface is easily scratched or damaged, and should be protected by the use of proper protective covers and storage racks, which are provided by the aircraft manufacturer or manufactured locally. It is easier to avoid scratches than to remove them. It is possible, however, to restore even a badly scratched surface to a good finish by buffing and sometimes sanding.

Aircraft MIMs and SRMs specify limits on the length, width, and depth of cracks, and in what areas they are allowed. These measurements are normally made by the use of an optical micrometer. If a scratch

exceeds the specified limitations, the surface must be replaced.

Before you sand or buff, be sure the plastic surface is clean. The buffing wheels and compounds should also be free of dirt and grit to avoid seriously scratching the surface during the polishing operation. If the buffing wheels have been used before, remove any hardened tallow by running the wheels against a metal edge.

It is important to remember that most plastic enclosures are thermoplastic and soften when heated. The friction of sanding or buffing too long or too vigorously in one spot can generate enough heat to soften or burn the surface. Also, plastic that has been deep-drawn, or formed to compound curvatures, has a tendency to return to its original thickness when excessive heat is applied. The best procedure is to keep either the wheel or plastic constantly in motion relative to one another. Keep the pressure against the wheel to a minimum, and change the direction of buffing often.

The procedures for removing scratches are as follows: A single deep scratch or imperfection is reduced by sanding to a number of small, shallow scratches. These scratches, in turn, are reduced to a larger number of still smaller scratches on a buffing wheel to which a fine abrasive is applied. These finest scratches are further reduced or filled in with tallow or wax. A final buffing or polishing brings the surface to a high gloss. The depth of the scratch will determine how many of these operations are necessary. Each step in the process must be performed thoroughly, or subsequent polishing will not remove scratches left by previous operations.

Sanding and buffing cause thickness variations in the plastic around the scratch. If skillfully done, these operations will cause only minor optical distortions, which will not be serious in most applications. Distortion may be reduced by gently polishing and feathering a fairly large area around the scratch. In critical optical sections, however, even minor distortions may cause serious deviations in sighting. Such sections, even though scratched, should not be sanded or buffed. If necessary, these sections are replaced.

SANDING.—Transparent plastics should never be sanded unless absolutely necessary, and then only when surface scratches, which may impair vision, are too deep for buffing. When sanding is necessary, the finest, smallest grit abrasive paper that will remove the scratch or other defect should be used first.

DO NOT SAND UNLESS ABSOLUTELY NECESSARY TO REMOVE DEEP SCRATCHES. HOLD SANDPAPER BY SMOOTH RUBBER OR WOODEN BLOCK AND OVER A WIDE AREA TO PREVENT OPTICAL DISTORTIONS. EXCESS PRESSURE IN SANDING OR BUFFING WILL BURN PLASTIC.

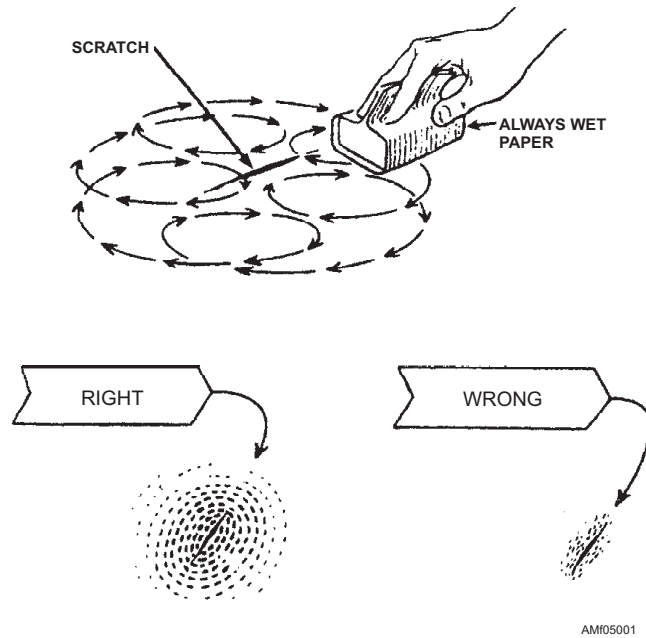

Figure 5-1.—Proper method of sanding plastic.

Normally, you will never need abrasive paper coarser than No. 320A; however, abrasive paper as coarse as No. 240A may be used if the situation warrants. The abrasive paper is wrapped around a felt-covered, wooden or rubber block, and the defective area is rubbed lightly, using plain water or water with a 2-percent soap content as a lubricant. Use circular strokes, as shown in figure 5-1. Never use a straight back-and-forth motion. Sand an area about two or three times the length of the defect in order to minimize optical distortion and excessive thinning of the plastic. The initial sanding should then be followed by similar treatments, using successively finer grades of sandpaper in the following sequence: Nos. 400A, 500A, and 600A. Wash the plastic after each operation. During each step, the deeper scratches left by the preceding grade of abrasive should be removed.

BUFFING.—To remove the fine, hairline scratches caused by sanding, transparent plastic may be buffed. It is often possible to remove scratches by buffing alone, provided the scratches are not too deep.

There are a number of standard commercial buffing compounds satisfactory for use on transparent plastic enclosures. They are usually composed of very fine alumina or similar abrasive in combination with wax, tallow, or grease binders. They are available in the form of bars or tubes for convenience in applying to the buffing wheel.

Plain tallow is often applied to the buffing wheel. It may be used in addition to buffing compound, or it may be used alone. In the latter case, tallow functions similar to wax as it fills in hairline scratches and gives a high gloss to the surface.

Buffing wheels are made of cotton cloth or felt. For removing scratches caused by sanding, an “abrasive” wheel and a “finish” wheel are needed (fig. 5-2). The abrasive wheel, which is relatively hard and to which buffing compound is applied, is used for removing the deeper scratches. The finish wheel, which is soft, is then used to bring the plastic to a high polish. Both wheels are made up of numerous layers of cloth discs, but the abrasive wheel is made hard by several rows of

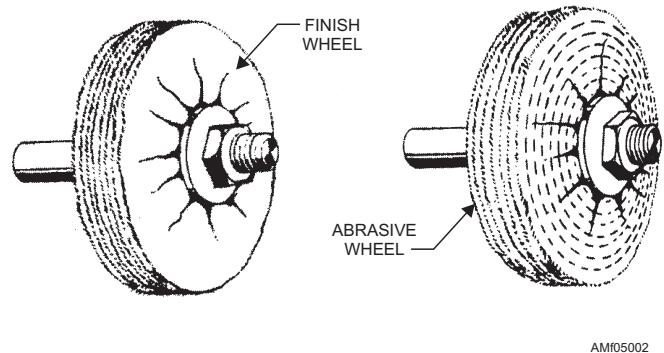

Figure 5-2.—Buffing wheels.

stitches, as shown in the illustration. The finish wheel is unstitched with spacers (washers) mounted between every fourth or fifth cloth disc. Power for turning the buffing wheel may be supplied by mounting it in a portable drill, as shown in figure 5-3. At the start of each buffing operation, the plastic must be clean and dry. Some of the buffing compounds now available will leave the surface clean so that washing is not necessary. Where necessary, however, washing should follow each step in buffing. If a panel has been sanded previously or is deeply scratched, the abrasive wheel should be used first. Apply fresh compound to the wheel and buff lightly along and across all scratches. Keep the plastic or wheel in motion to prevent generating too much heat, thus damaging the plastic. Complete the buffing operation by using the finish wheel, bringing the plastic surface to a high gloss. After all scratches have been removed with the finish wheel, a coat of wax should be applied by hand.

CAUTION

Hand polishing is recommended in critical vision areas. Overheating transparent plastic, by buffing, induces internal stresses and optical distortions.

Installing Plastic Panels

There are a number of methods for installing transparent plastic panels in aircraft, some of which are shown in figures 5-4 through 5-7. Which method the aircraft manufacturer uses depends upon the position of the panel in the aircraft, the stresses to which it will be subjected, and a number of other factors. In installing a replacement panel, always follow the same mounting method used by the manufacturer of the aircraft.

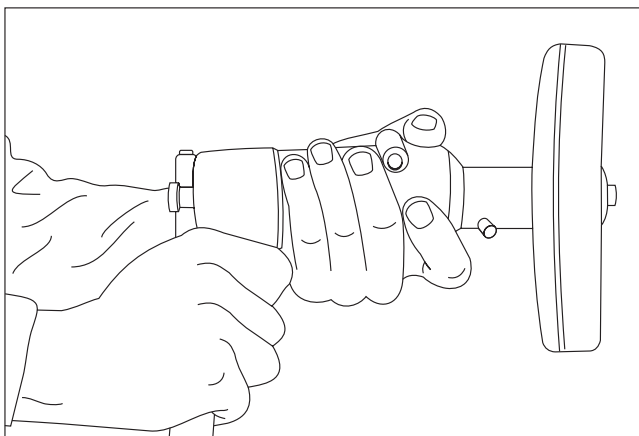

AMF05003

Figure 5-3.—Buffing wheel mounted in portable drill.

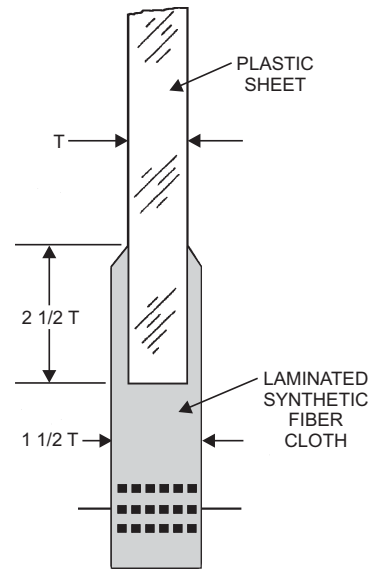

AMF05004

Figure 5-4.—Approved edge attachment for solid plastic.

The following general rules apply to all types of mountings. Fitting and handling should be done with masking paper in place, although the edges of the paper may be peeled back slightly and trimmed off for installation.

Since transparent plastic is brittle at low temperatures, installation of panels should be done at normal temperatures. Plastic panels should be mounted between some type of gasket material to make the installation waterproof, to reduce vibration, and to help distribute compressive stresses on the plastic. Minimum packing thickness is one-sixteenth of an inch. Rubber, fiber glass impregnate, and nylon are the most commonly used gasket materials.

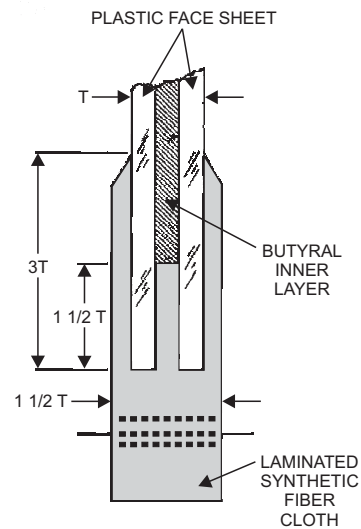

AMF05005

Figure 5-5.—Approved edge attachment for laminated plastic.

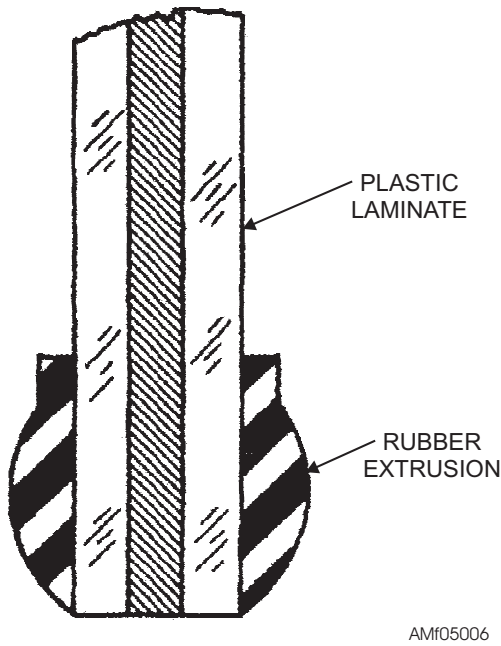

Figure 5-6.—Typical sighting dome attachment.

Since plastic expands and contracts three times as much as metal, suitable allowances for dimensional changes with temperature must be made. Minimum clearances between the frame and plastic are listed in *Fabrication, Maintenance and Repair of Transparent Plastics*, NAVAIR 01-1A-12, or the applicable MIM. Clearances should be equally divided on all sides.

Screw torquing procedures should be in accordance with the applicable MIM. Plastic panels should not be installed under unnatural stresses. Each screw must be torqued, as specified in the MIM, to enable it to carry its portion of the load. If a plastic panel is installed in a binding or twisted position and

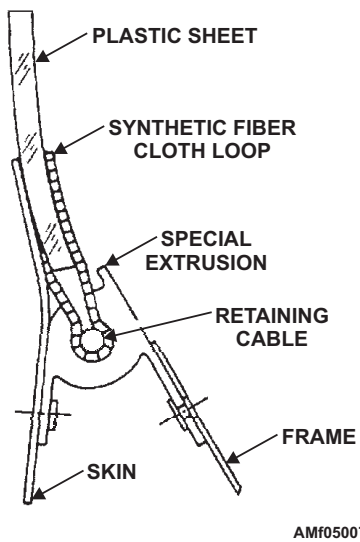

Figure 5-7.—Typical loop edge attachment.

screws are not torqued correctly, the plastic panel may fail while the aircraft is undergoing normal taxiing and flight operations.

When you remove a plastic panel, there may be several different lengths of screws to be removed. You will save a lot of time by acquiring the habit of keeping screws separated. An easy way to do this is to draw a diagram of the panel on cardboard. Puncture each screw hole, with an awl, through the cardboard. As each screw is removed from the panel, it is installed in its respective position on the cardboard. This is done with each screw as it is removed.

During installation of the panel, remove each screw from the cardboard and reinstall it in the same hole from which it was removed until all of the screws are reinstalled. If any screws or other fasteners are damaged during removal or reinstallation, the part replaced must be the same part number as the damaged part. Some fasteners are required to be of nonmagnetic material because of their location near compasses and other instruments. The specific part number for each fastener can be found in the Illustrated Parts Breakdown (IPB) for the aircraft.

- Q5-1. What are cracks and small surface fissures in transparent plastic materials called?
- Q5-2. What should you use to clean excessive masking paper adhesive residue from plastic?
- Q5-3. What is normally used to measure scratches on plastic materials?
- Q5-4. To sand out scratches in transparent plastic, what is the maximum coarse number of abrasive paper that you may use?
- Q5-5. What substance is often applied to the buffing wheel in place of, or in addition to, a buffing compound that acts similar to wax to fill hairline scratches and provides a high gloss to plastic surfaces?
- Q5-6. How many times greater will plastics expand and contract as compared to metal?

REPAIRING REINFORCED PLASTIC

This section covers the materials and procedures to be used in repairing reinforced plastic and sandwich construction components. The procedures discussed are general in nature. When actually repairing reinforced plastic and/or sandwich construction components, refer to the applicable maintenance instruction manual or structural repair manual.

The repair of any damaged component made of reinforced plastic requires the use of identical materials, whenever they are available, or of approved substitutes for rebuilding the damaged portion. Abrupt changes in cross-sectional areas must be avoided by tapering joints, by making small patches round or oval instead of rectangular, and by rounding the corners of all large repairs. Uniformity of thickness of core and facings is exceedingly important in the repair of radomes. Repairs of punctured facings and fractured cores necessitate removal of all the damaged material, followed by replacement with the same type of material and in the same thickness as the original. All repairs to components housing radar or radio gear must be made in accordance with the manufacturer's recommendations. This information may be found in the aircraft structural repair manual or in drawings and specifications.

Before a thorough inspection of the damage can be made, the area should be cleaned with a cloth saturated with methyl ethyl ketone (MEK). After drying, the paint should be removed by sanding lightly with No. 280 grit sandpaper, and then clean the sanded area with MEK. The extent of damage can then be determined by tapping the suspected areas with a blunt instrument. You could use a coin as a blunt instrument, such as a quarter, to perform the tap test. This is referred to as the "coin tap" method. You should never use a hammer as a blunt instrument. The damaged areas will have a dull or dead sound, while the undamaged areas will have a clear metallic sound.

Damages are divided into four general classes: surface damage, facing and core damage, puncture damage (both facings and core), and damage requiring replacement.

Repairing Surface Damage

The most common types of damage to the surface are abrasions, scratches, scars, dents, cuts, and pits. Minor surface damages may be repaired by applying one or more coats of room-temperature catalyzed resin to the damaged area. More severe damages may be repaired by filling with a paste made from room-temperature resin and short glass fibers. Over this coated surface, apply a sheet of cellophane, extending 2 or 3 inches beyond the repaired area. After the cellophane is taped in place, start in the center of the repair and lightly brush out all the air bubbles and excessive resin with your hand or a rubber squeegee towards the outer ridge of the repair. Allow the resin to cure at room temperature, or if necessary, the cure can

be hastened by the use of infrared lamps or hot sandbags. After the resin has been cured, remove the cellophane and sand off the excess resin; then, lightly sand the entire repaired area to prepare it for refinishing.

PLY DAMAGE (SANDWICH LAMINATES).—When the damage has penetrated more than one ply of the cloth in sandwich-type laminates, the repair may be made by using the scarfed method, shown in figure 5-8. This repair is made in the following manner: Clean the area thoroughly, and then sand out the damaged laminate plies, as shown in view B. The area should be sanded to a circular or oval shape, and then the area should be tapered uniformly down to the deepest penetration of the damage.

The diameter of the scarfed (tapered) area should be at least 100 times the depth of the penetration. You should exercise care when using a mechanical sander. Excess pressure on the sander can cause the sandpaper to grab, resulting in the delamination of undamaged plies.

CAUTION

The sanding of glass cloth reinforced laminates produces a fine dust that may cause skin irritation. In addition, if you breathe an excessive amount of this dust, it may be injurious; precautions as to skin, eyes, and respiration protection must be observed.

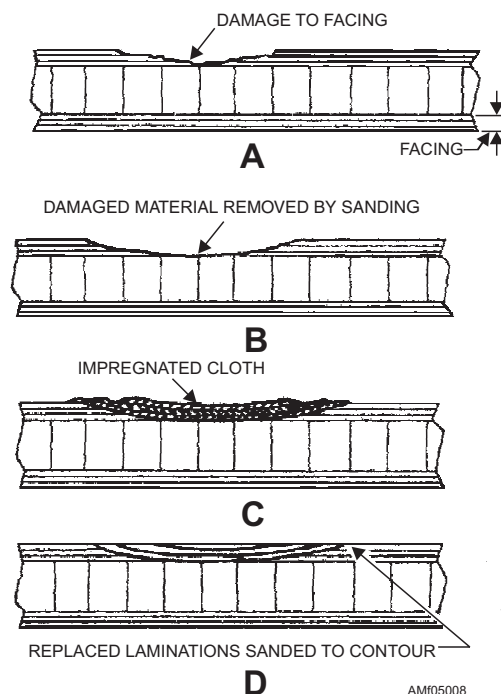

Figure 5-8.—Ply repair (scarfed method).

Clean the area thoroughly, brush coat the sanded area with one coat of room-temperature catalyzed resin, and apply the contoured pieces of resin-impregnated cloth, as shown in view C of figure 5-8. Tape a sheet of cellophane over the built-up repair and work out the excess resin and air bubbles. Cure the repair in accordance with the resin manufacturer's instructions, and then sand the surface down (if necessary) to the original surface of the facing.

PLY DAMAGE (SOLID LAMINATES).—Ply damage to solid laminates may be repaired by using the scarfed method described for sandwich-type laminates, shown in figure 5-8, or the stepped method, shown in figure 5-9, view A, may be used.

When the wall is being prepared for the stepped repair, a cutting tool with a controlled depth will facilitate the cutout and should be used to avoid

possible damage to the layers underneath. If the layer of glass cloth underneath is scratched or cut, the strength of the repair will be lessened. You should exercise care not to peel back or rupture the adhesion of the laminate layers beyond the cutout perimeter. You can accomplish removal of the cutouts by peeling from the center and working carefully to the desired perimeter of the cutout. Scrape each step, wipe clean with cloths moistened with MEK, and allow to dry thoroughly. Cut the replacement glass fabric pieces to an exact fit, with the weave directions of the replacement plies running in the same direction as the existing plies. Failure to maintain the existing weave direction will result in a repair that is greatly under strength. Replace each piece of fabric, being careful to butt the existing layers of fabric plies together, but do not overlap them. The laminate layers should be kept to the proper matching thickness.

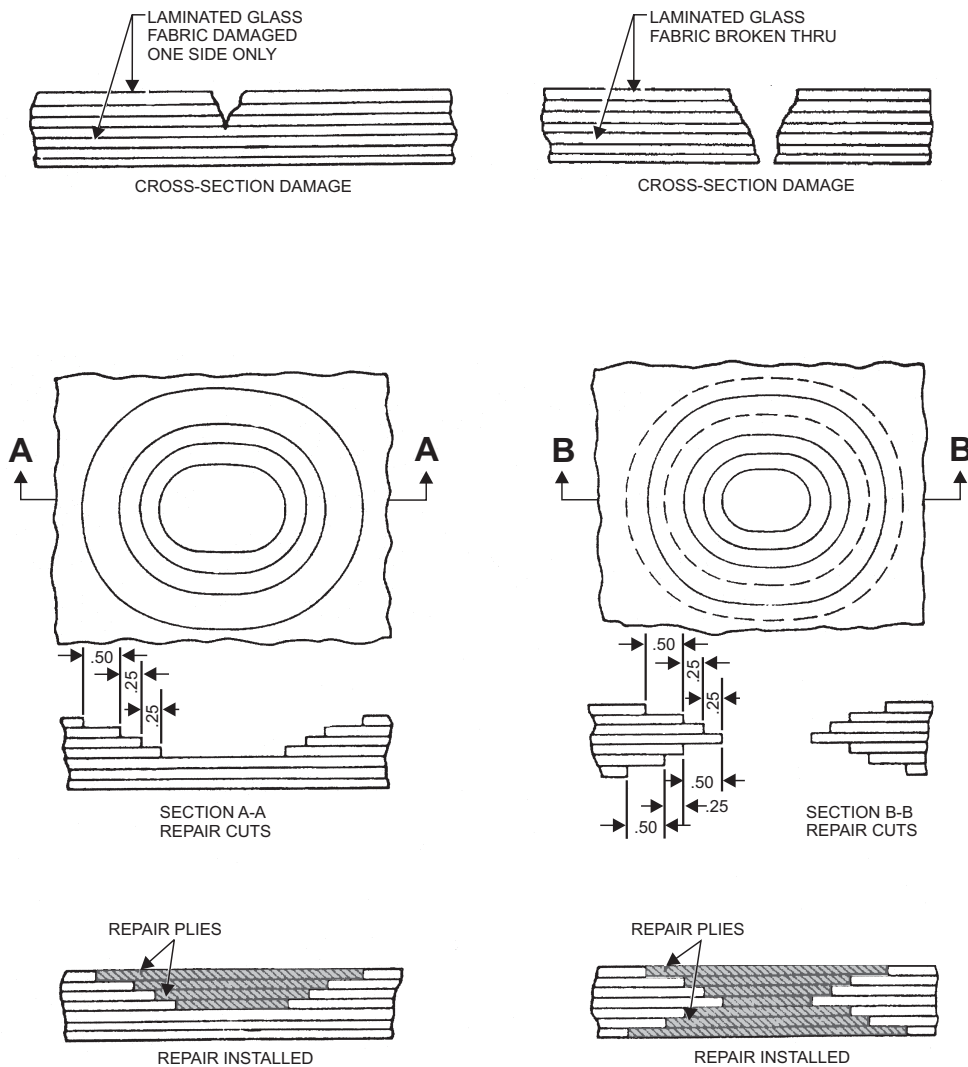

AM05009

Figure 5-9.—Repair of solid laminates (stepped method).

When the entire wall has been penetrated, as shown in figure 5-9, view B, one-half of the damaged plies should be removed from one side and the replacement buildup completed; then, repeat removal and buildup procedure on the opposite side. If the damage occurs over a relatively large or curved area, make up a plaster mold that conforms to the contour and extends 1 inch past the damage, and insert it in the damaged area when repairing the first half of the plies. When the stepped method of repair is used, the dimensions should be maintained as illustrated.

In areas that have become delaminated, or that contain voids or bubbles, clean with MEK and determine the extent of the delamination; and then drill holes at each end or on the opposite sides of the void by using a No. 55 drill bit, extending through the delaminated plies. Figure 5-10 shows the procedure for repair of delaminated plies.

Additional holes may be needed if air entrapment occurs when you inject the resin. Use a hypodermic needle or syringe and slowly inject the appropriate amount of resin until the void is filled and the resin flows freely from the drilled holes. After the voids are completely filled, bring the area down to proper thickness by working the excess resin out through the holes, and then cure and refinish.

Repairing Facing and Core Damage

The repair of facings and cores requires more than one method of repair. Special attention must be given to the type of core used.

HONEYCOMB CORE.—The repair of facings and cores requires more than one method of repair. Special attention must be given to the type of core used. Damages extending completely through one facing of the material and into the core require removal of the damaged core and replacement of the damaged facings in such a manner that normal stresses can be carried over the area. The scarfed method, illustrated in figure 5-11, is the preferred method for accomplishing small repairs of this type. Repairs of this type may be accomplished as follows:

Carefully trim out the damaged portion to a circular or oval shape and remove the core completely to the opposite facing. Be careful not to damage the opposite facing. The damaged facing around the trimmed hole is then scarfed back carefully by sanding. The length of the scarf should be at least 100 times the facing thickness, as shown in view B of figure 5-11. This scarfing operation must be done very accurately to a uniform taper.

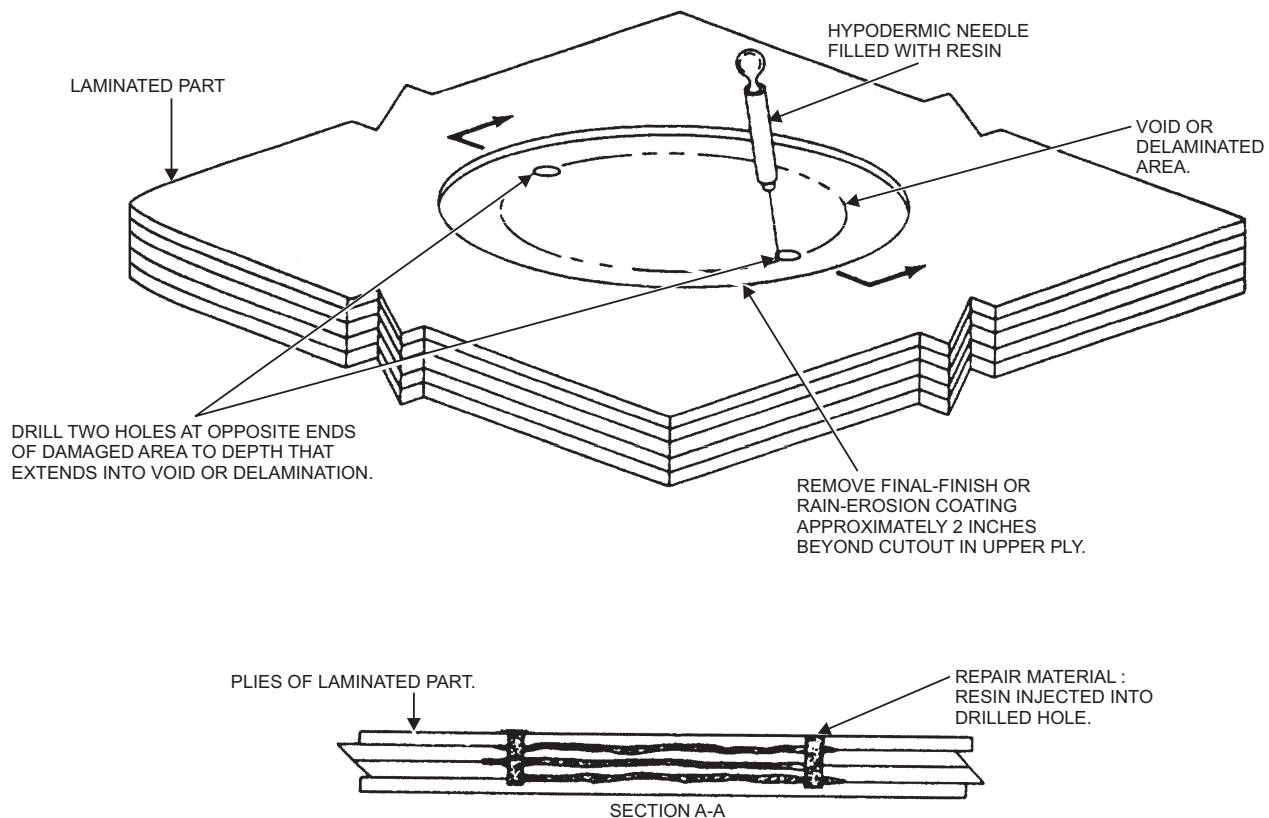
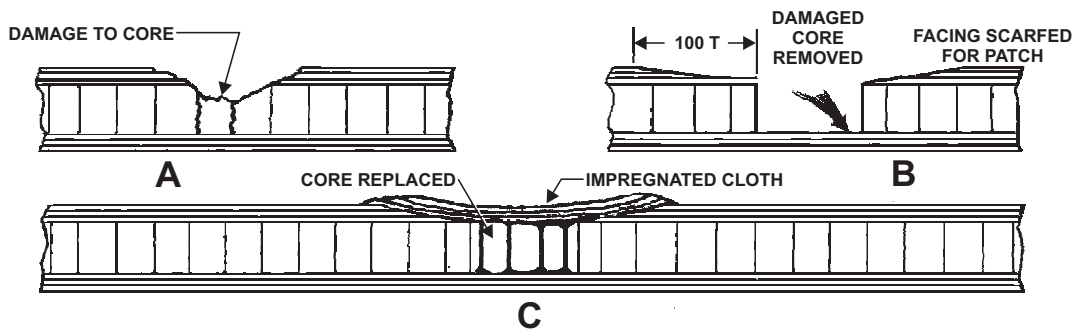

Figure 5-10.—Delaminated ply repair.

AMf05010



AMf05011

Figure 5-11.—Honeycomb-type core repair.

Cut a piece of replacement core material (or a suitable substitute) to fit snugly in the trimmed hole. It should be equal in thickness to the original core material. Brush coat the repair area and the replacement honeycomb, exercising care to prevent an excessive amount of resin from entering the honeycomb cells.

Insert the honeycomb repair section and place the resin-impregnated cloth over the repair area, as shown in view C of figure 5-11. Cover the repair area with cellophane sheeting, and cure the repair in accordance with the resin manufacturer's instructions.

After the repair has been cured, sand the surface to its original contour. The entire area should be lightly sanded before refinishing.

FOAM CORE.—The damaged core should be removed by cutting perpendicular to the surface of the face laminate opposite the damaged face. Scrape the inner facing surface clean, making sure there is no oil or grease film in the area, to ensure good bondage of the foam to the laminate. Fill the area where the core has been removed with the filler material specified in the aircraft structural repair manual. Figure 5-12 shows the replacement of a foam core.

NOTE: Do not use MEK to clean the damage as it may soften and weaken the foam.

Repairing Puncture Damage

The repair of punctures differs as to the method used. Repair of honeycomb cores is different from the repair of foam cores.

HONEYCOMB CORE.—Repairs to damages completely through the sandwich structure may be accomplished either by the scarfed method (similar to the repair described for damage extending into the core) or the stepped method.

The scarfed method is normally used on small punctures up to 3 or 4 inches in maximum dimension and in facings made of thin cloths (which are difficult to peel). The stepped method is usually employed on larger repairs to facings composed of thick cloths.

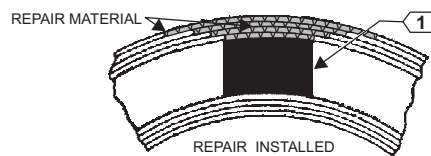
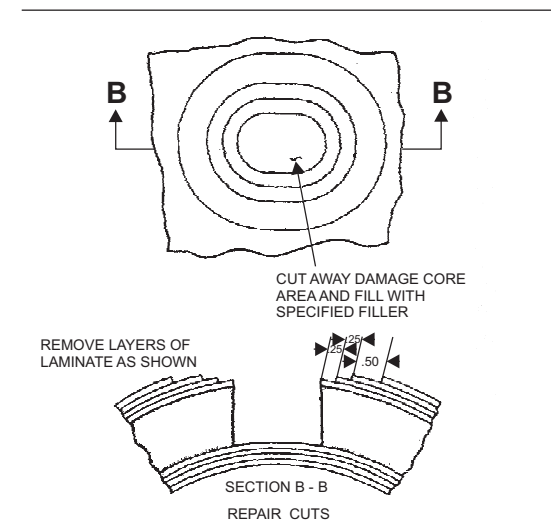
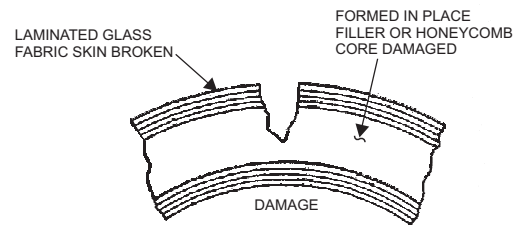

NOTE
 1 REPLACE DAMAGED CORE MATERIAL WITH SPECIFIED FILLER

AMf05012

Figure 5-12.—Foam-type core repair.

The scarfed method of repair for punctures is the same as that used for damage extending into the core, with the exception that the opposite side of the sandwich is provided with a temporary mold or block to hold the core in place during the first step. See view C in figure 5-13.

After the first facing repair is cured completely, the mold and the shim (temporarily replacing the facing on the opposite side) are removed. The repair is then completed by repeating the procedure used in the first step. When this facing is cured, the surface should be sanded down to the original contour and the repair area lightly sanded in preparation for refinishing.

When you use the stepped method of repair, the damaged area is first trimmed out to a round or oval shape or to a rectangular or square shape (preferably having rounded corners).

The individual plies are then cut out as shown in figure 5-14. Each ply is "stepped" back 1 1/2 inches and trimmed out by using a sharp knife. The sides of the repair should be parallel with the weave of the cloth, if possible.

NOTE: Do not cut through more than one layer of cloth. If the layer of cloth underneath is scratched, the strength of the repair will suffer.

The opposite facing is shimmed and backed up with a mold, and the core material is inserted as previously described. The outer repair plies are soaked in the resin and laid over the damaged area. An extra layer of thin cloth is laid over the repair area to extend

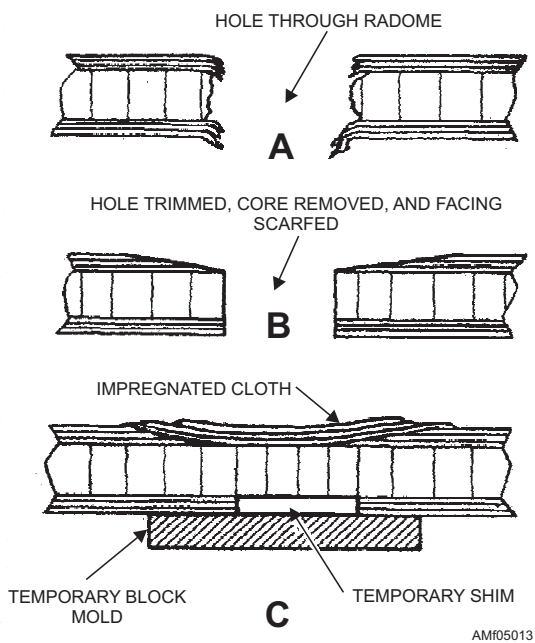

Figure 5-13.—Scarfed repair method.

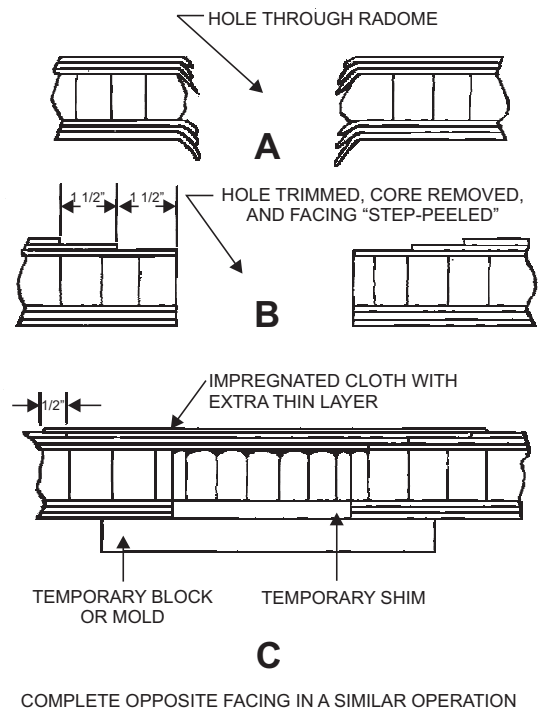

Figure 5-14.—Stepped repair method.

one-half inch over the undamaged facing. The repair area is then covered with a sheet of cellophane to apply pressure, and then it is allowed to cure. The inner facing is then replaced in the same manner as the outer facing. After the inner repair has been cured, the entire repair area should be sanded to the original contour and prepared for refinishing.

FOAM CORE.—When the puncture penetrates the entire wall, remove the damaged core and face laminates to one-fourth inch past the perimeter of the hole on the inner face. Make a plaster support to replace the removed core, conforming to the curvature of the inside layer of the inner face. Figure 5-15 shows a punctured repair with a plaster support.

After repair to the inner face has been completed, remove the plaster support and continue the repair on the opposite side.

Finishing Repaired Areas

In the repair of reinforced plastic parts, the final step is to refinish the part with a finish identical to the original, or an acceptable substitute. In refinishing radomes and other surfaces that enclose electronic equipment, consult NAVAIR 01-1A-22. Do not use metallic pigmented paints or other electronic reflective-type materials because of undesirable

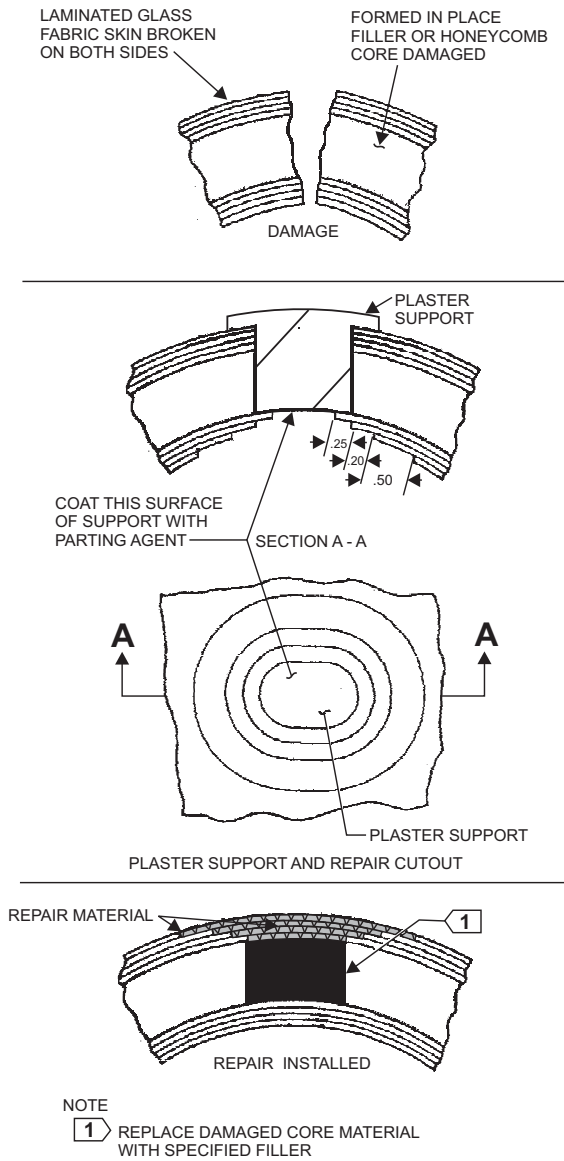

Figure 5-15.—Foam-type puncture repair.

shielding and interference effects. Always use the materials recommended in the applicable structural repair manual for refinishing both the interior and exterior surfaces of reinforced plastic components.

Reinforced plastic components whose frontal areas are exposed to high speeds are frequently coated with a rain erosion coating. Rain erosion coatings protect the component against pits that are caused by raindrops hitting the component at high aircraft speeds. These pits or eroded areas can cause delamination of the component glass cloths if allowed to progress unchecked.

Rain erosion-resistant coatings for reinforced plastic components conform to Specification MIL-C-7439. Coatings that conform to this specification are classified as Class I and Class II.

Class I is a rain erosion-resistant coating that is furnished in kit form. This kit consists of a primer, accelerator, diluting solvent, and neoprene.

Class II is a rain erosion-resistant coating with an additional surface treatment to minimize radio noise resulting from precipitation static on the coated surface. This coating is also supplied in kit form and consists of a primer, accelerator, diluting solvent, neoprene, and antistatic coating.

These kits (MIL-C-7439, Classes I and II) are packaged unaccelerated to provide longer shelf life. The neoprene is ready to use only after the catalyst (accelerator) has been added. The material in these kits should be mixed and applied in accordance with the instruction sheet supplied by the kit manufacturer.

Observing Safety Precautions

The following general safety precautions should be observed when you make repairs to reinforced plastic components. You should review these safety precautions before attempting any repairs to reinforced plastics.

1. Local station safety regulations as to fire and health hazards must be complied with.
2. All solvents are flammable; therefore, observe proper handling procedures.
3. Personnel involved in the mixing or handling of catalyzed resin prior to the curing operations should wear rubber gloves. After using rubber gloves, personnel should clean their hands with soap and water and rinse with vinegar to neutralize any catalyst particles.
4. Never mix the catalyst and promoter together, as they are explosively reactive as a mixture. Always mix the promoter with the resin first, and then add the catalyst to the mixture.
5. The toxicity of polyester formulation has not been definitely established. Some of the components are known to cause nasal or skin irritation to certain individuals. Adequate ventilation should be provided.
6. The sanding operation on glass cloth reinforced laminates gives off a fine dust that may cause skin, eyes, or respiratory irritations. Inhalation of excessive amounts of this dust should be avoided. Protection should be provided for respiration, eyes, and skin.
7. Do not store catalyzed resin in an airtight container or an unvented refrigerator.

REPAIRING SANDWICH CONSTRUCTION MATERIALS

The repairs discussed here are applicable to structural-type sandwich construction, which consists of aluminum alloy facings bonded to aluminum honeycomb and balsa wood cores.

Repairing Minor Surface Damage

The most common types of damage to the surface are abrasions, scratches, scars, and minor dents. These minor surface damages require no repair other than the replacement of the original protective coating to prevent corrosion if no breaks, holes, or cracks exist.

Repairing Delaminations

Facing-to-core voids of less than 2.5 inches in diameter can usually be repaired by drilling a series of holes 0.06 to 0.10 inch in diameter in the upper facing over the void area. An expandable forming resin, such as Thermofoam 607 or equivalent, is then injected through the holes with a pressure-type caulking gun. When the void is on the lower surface of the panel, only sufficient resin must be injected to completely fill the void. With voids on the upper surface, the core area should be filled until the resin comes out of the injection holes. These holes should be sealed with a thermosetting epoxy resin adhesive, and the entire assembly cured with lamps, as required for the adhesive system.

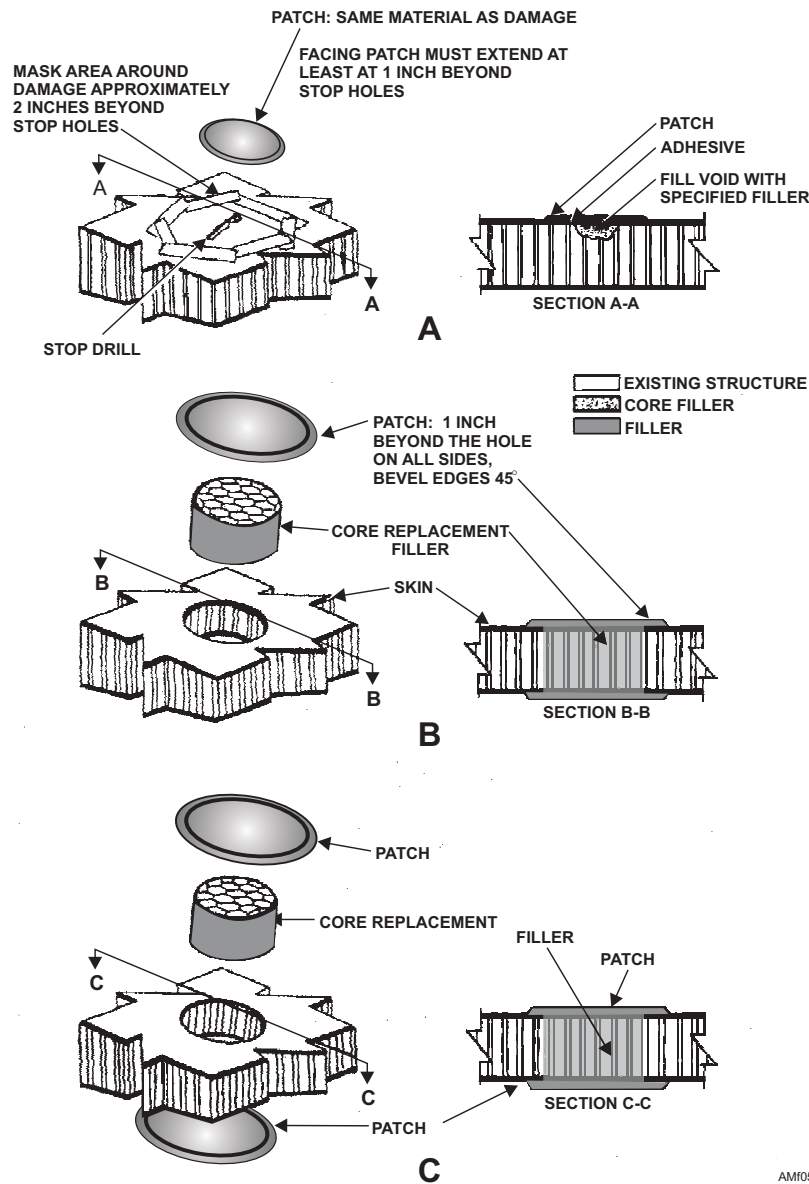

AM105016

Figure 5-16.—Sandwich construction puncture repair (honeycomb core).

When the void areas are large, it is necessary to remove the facing over the damaged area and follow the repair procedures for a puncture. See figure 5-16.

Repairing Punctures

A puncture is defined as a crack, break, or hole through one or both skin facings with resulting damage to the honeycomb and/or balsa wood core. The size of the puncture, amount of damage to the core, assembly to be repaired (rudder, elevator, etc.), and previous repairs to the damaged assembly are factors to be considered in determining the type of repair to be made. Damage to a honeycomb and/or balsa wood core assembly that exceeds a specified length or diameter in inches or the total number of repairs exceeds a specified percentage of the total bonded area necessitates replacement of the assembly.

NOTE: These figures are found in the applicable structural repair manual.

HONEYCOMB CORE.—The repair shown in figure 5-16, view A, is used when a puncture through one skin facing has caused only minor damage to the core material. To repair this type of damage, proceed as follows:

Cover the component with a suitable protective covering (polyvinyl sheet or Kraft paper). Cut out a section of the protective covering that will extend approximately 2 inches beyond the damaged area. Use masking tape to hold the cutout in place. Stop-drill as necessary through the skin facing only.

Strip the paint and protective coating 1 1/2 inches beyond the stop drilled holes. Then, clean the stripped area with a special cleaning paste. Fill the void with the specified filler material to within approximately 0.063 inch of the skin facing, and cure as directed.

Prepare a round or oval patch large enough to overlap the damaged area at least 1 inch. Apply sealant to the undersurface of the patch and to the filler and skin surface. Install the repair patch, maintaining correct overlap, and clamp to the assembly to assure contact with the skin facing. Cure as directed. Remove the excess adhesive, and refinish as necessary.

The repair shown in figure 5-16, view B, is used when a puncture through one skin facing has caused extensive damage to the honeycomb core. When the core has been damaged extensively, the damaged material must be replaced.

Prepare the assembly as previously described. Cut out the damaged skin facing with a hole saw or aviation snips. File the edges of the hole smoothly. Using a pocketknife, carefully cut out the damaged core.

CAUTION

Do not damage the opposite facing. Install a new core filler and complete the repair as described in view A of figure 5-16.

The repair shown in figure 5-16, view C, is used when both skin facings and the core have been damaged. To make this repair, use the same procedures as described for views A and B of figure 5-16.

BALSA WOOD CORE.—The repair shown in figure 5-17 is used when no gain in structural strength is

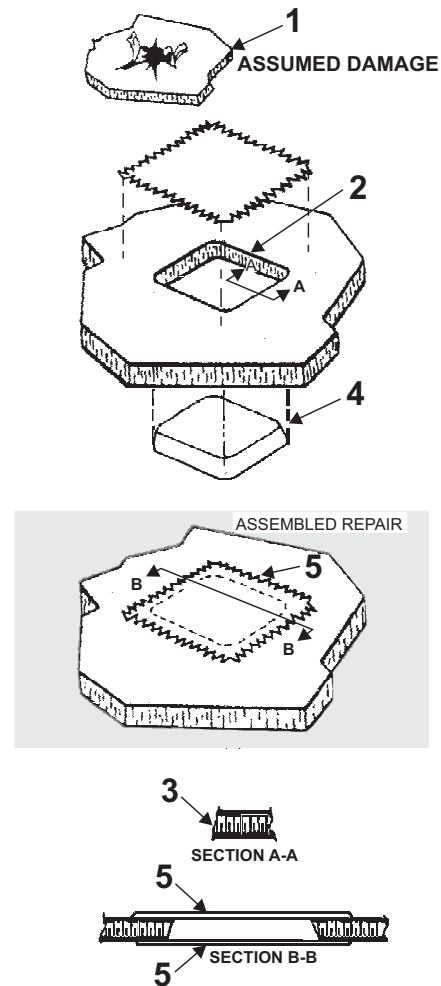

Figure 5-17.—Balsa wood repair with filler plug and fabric patch.

AM105017

desired, and it is only to be used for sealing holes of 1 square inch or less in external surfaces. The damaged area (1) should be cut out to a smooth circular or rectangular shape. A 3/8-inch minimum radius (2) must be provided at the corners of rectangular cutouts.

NOTE: This information applies to all repairs made to balsa wood core panels. In cutting out the damaged area, you must take care not to separate the metal faces from the core. You can accomplish this by using a very fine-toothed coping or hacksaw blade for straight cuts, and cylindrical saws (hole saws) for cutting holes or rounding corners.

After the damaged section has been cut out, file the edges smooth by using a fine cut file only. Then, inspect the area (3) for separation of the skin facing from the balsa wood core. If the facing has separated from the core, rebond the two surfaces, using the procedures outlined in the previous section on skin separation. Then, complete the repair by using the approved filler material and two fabric patches, as shown in views (4) and (5) of figure 5-17.

Figure 5-18 shows one flush-type balsa wood core repair that is used on puncture damages larger than 1 inch. To make this type of repair, cut out the damaged area (1) as previously described. After the damaged area has been cut out (2), cut back the inner metal face 1 inch and remove the core material. See view (3) of figure 5-18.

Inspect for adhesion of the face to the core, and seal the exposed filler material to prevent the entry of moisture. Lay out the required rivet pattern and drill pilot holes in the panel. See view (4) of figure 5-18.

NOTE: The rivet size, rivet spacing, and number of rows of rivets are given in the appropriate repair section of the applicable structural repair manual.

Next, prepare two patch plates; a wood, plywood, or phenolic filler; and a metal filler. See views (5), (6), and (7) of figure 5-18. The outer patch plate should fill the hole in the core, and the inner patch plate should overlap the hole in the core approximately 1 inch for each row of rivets.

Locate the patch plates and wood filler. Using the pilot holes in the panel as a guide, drill pilot holes through the patch plates and wood filler. The patch plates and wood filler are then bonded to the panel using the specified adhesive. Next, locate the metal filler, and drill pilot holes through both patch plates and the wood filler.

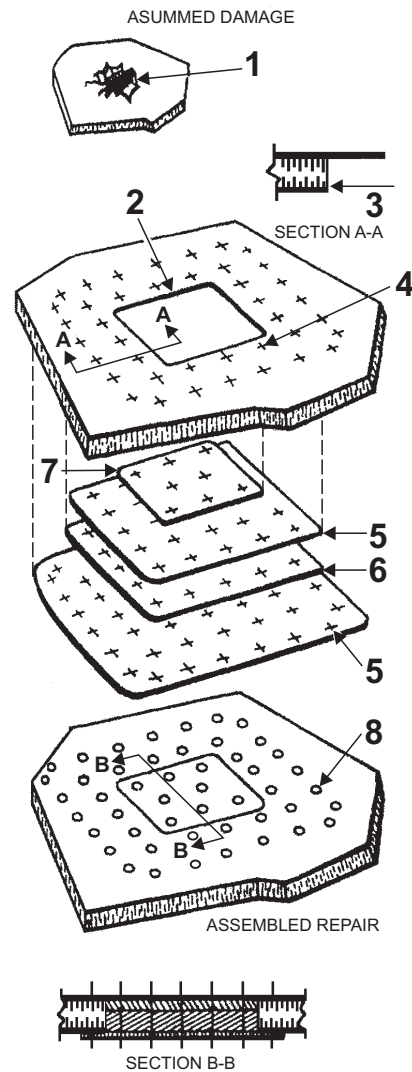

AM05018

Figure 5-18.—Balsa wood repair with flush patch.

All pilot holes are then size drilled and machine or press countersunk, as applicable. Complete the repair by installing the specified rivets. See view (8) of figure 5-18.

When aerodynamic smoothness is not desired, a nonflush patch such as the one shown in figure 5-19 can be used. Notice that this type of repair uses two patch plates, a wood filler, and nonflush rivets. Otherwise, the procedures described for the repair shown in figure 5-18 are applicable to this type of repair.

Repairing the Trailing Edge of an Airfoil

A trailing edge is the rearmost edge of an airfoil (wing, flap, rudder, elevator, etc.). It may be a formed or machined metal strip or possibly a metal-covered honeycomb or balsa wood core material that forms the

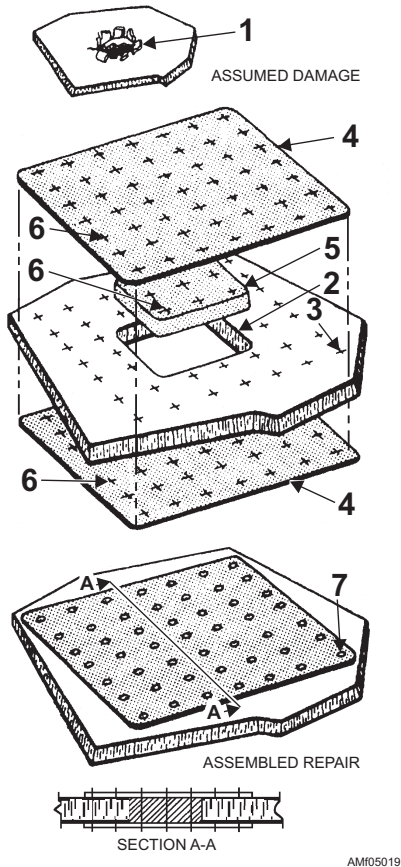

Figure 5-19.—Balsa wood repair with nonflush patch.

shape of the edge by tying the ends of a rib section together and joining the upper and lower skins. These trailing edges are very easily damaged. The majority of this type of damage can be avoided if care is taken when moving aircraft in confined spaces, and/or when positioning ground support equipment around parked aircraft. The trailing edges on some high-performance aircraft are almost knife-edge in construction. You must take extreme care when working around these surfaces to avoid injury.

A typical trailing edge repair to a sandwich construction assembly is shown in figure 5-20.

You may use the lap or flush patch, depending on the size of the damage, the type of aircraft, and the assembly or control surface to be repaired. Normally, the flush patch is used on control surfaces to ensure aerodynamic smoothness.

Q5-7. When repairing the surface of reinforced plastics and sandwich construction laminates, what should you use over the build-up repair area to work out the excess resin and air bubbles?

Q5-8. In addition to the stepped method, what other method of repair may be used to ply damage to solid laminates?

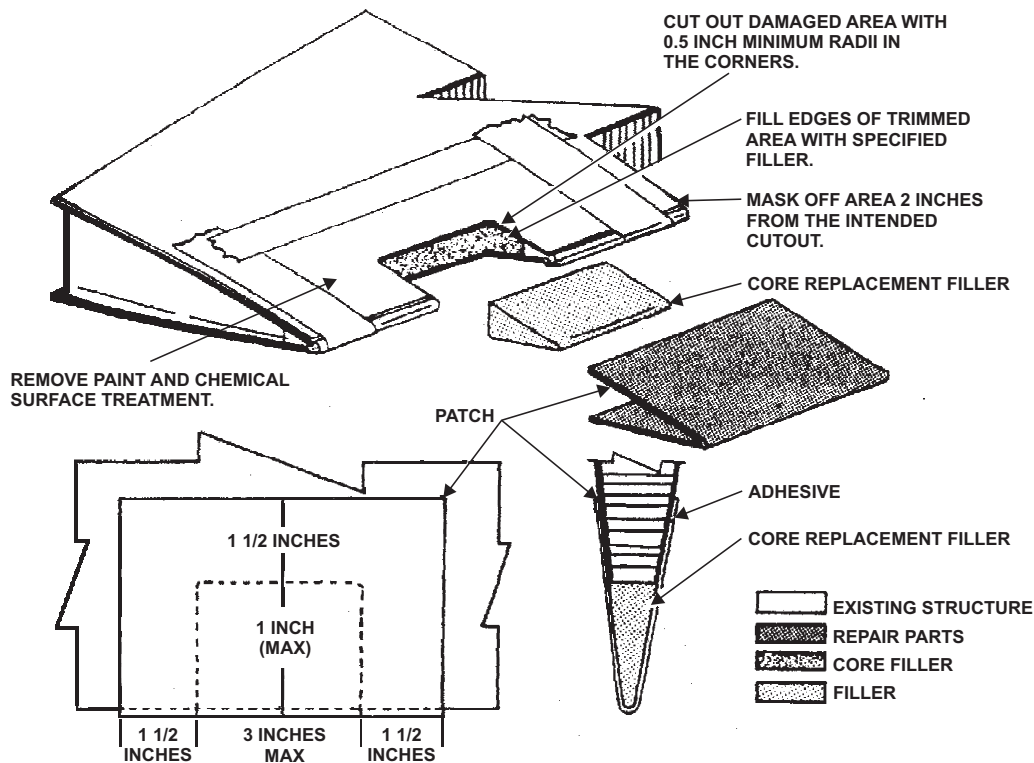

Figure 5-20.—Trailing edge repair (sandwich construction).

- Q5-9. What type of coating is frequently used to protect frontal surfaces of reinforced plastics exposed to high speeds?
- Q5-10. A hole, break, or crack in one or both facings, resulting in damage to the honeycomb/core, is referred to as what type of damage?
- Q5-11. What type of repair patch is normally used to ensure aerodynamic smoothness on aircraft control surfaces?

TYPES OF ADVANCED COMPOSITE MATERIALS

The reduced availability of natural resources, the increasing costs of production, and the apparent limit to our ability to fabricate high strength-to-weight metallic components necessitated the development of new materials to meet the demands of aerospace technology. In the following text, you will be introduced to the materials that provide high-performance capability now, with great expectations for the future. These materials are called *advanced composite materials* and will be used to replace some of the metals currently used in aircraft construction.

Advanced composites are materials that consist of a combination of high-strength stiff fibers embedded in a common matrix (binder) material, generally

laminated with plies arranged in various directions to give the structure strength and stiffness.

The much stiffer fibers of boron, graphite, and Kevlar® have given composite materials structural properties superior in strength to the metal alloys that they have replaced. Specific applications of advanced composite materials and approximate percentages of total aircraft structures for some of our modern-day aircraft are shown in table 5-1.

Composites are attractive structural materials because they provide a high strength-to-weight ratio and offer design flexibility. The function of a composite is to replace heavy/dense metals with stronger, lighter weight structural components, allowing lightweight aircraft to carry payloads farther distances using less fuel. In contrast to traditional materials of construction, these materials can be adjusted to more efficiently match the requirements of specific applications.

These materials are highly susceptible to impact damage, with the extent of damage being visually difficult to determine. A nondestructive inspection (NDI) is required to analyze the extent of damage and effectiveness of repairs.

Composites are classed by the type of reinforcing elements. These elements may be fibers, particle, flake, or laminar materials. They are further classified by the

Table 5-1.—Aircraft Advanced Composite Application Usage

Aircraft	Advanced Composite Application	% Usage
F/A-18	Graphite/Epoxy Wings, Horizontal and Vertical Stabilizers, and Access Doors	45%
AV-8B	Graphite/Epoxy Wings, Horizontal Stabilizers, Overwing Fairing, Forward Fuselage, and Control Surfaces	40%
SH-60B	Kevlar®/Epoxy Gearbox, Transmission Pylon, Drive Shaft and Nose Cover	20%
SH-60F	Graphite/Epoxy Rotor Blade Trailing Edge and Scarf Joints	20%
F-14	Boron/Epoxy Horizontal Stabilizer	.04%
CH-53E	Kevlar®/Epoxy Upper and Lower Canopy, and Drive Shaft Cover	20%

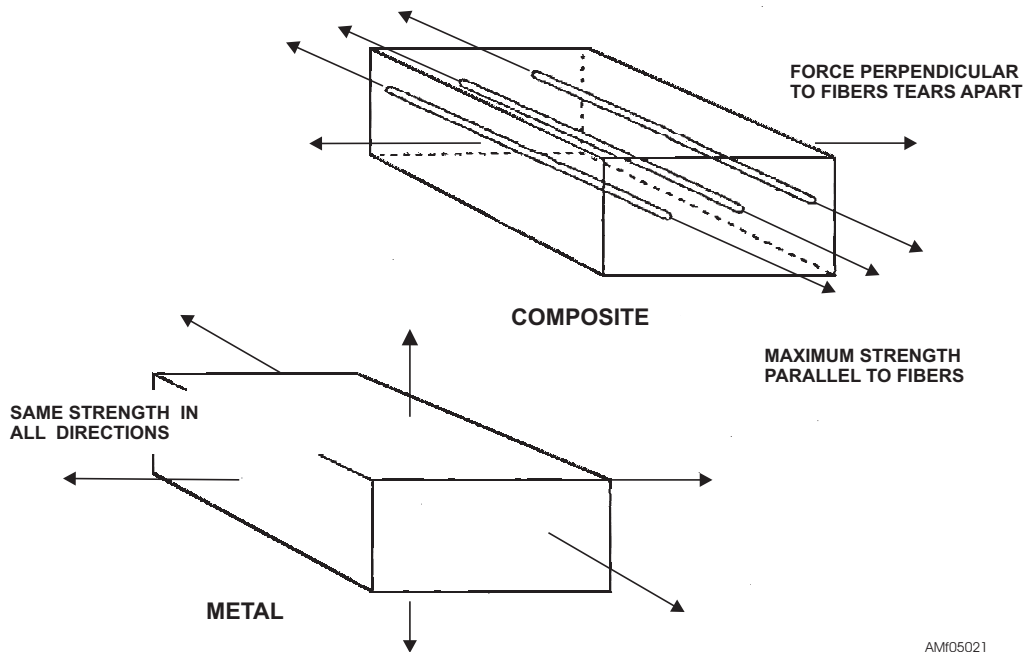

AM05021

Figure 5-21.—Design properties comparison.

composition of the reinforcing materials and by the type of matrix materials.

The primary factors taken into consideration when designing composites are the costs (research and development, production, fuel economy), type of application (load requirements of the structure, adjoining materials, service-life requirements), mission and maintenance requirements, and operational environment (hot/cold weather, relative humidity, altitude, land/carrier based).

The comparative properties of composites and metals are that metals have almost the same physical

and mechanical strengths equal in all directions. Stresses and strains are equally transmitted in all directions. Composites can have different physical and mechanical strengths in different directions, and are considered anisotropic or quasi-isotropic. These strengths are determined by the fiber orientation patterns. The patterns are unidirectional, bidirectional or quasi-isotropic. Maximum strength is parallel to the fibers, and loads at right angles to the fibers tend to break only the matrix. See figure 5-21. Metals and composites respond differently when subjected to loads. See figure 5-22.

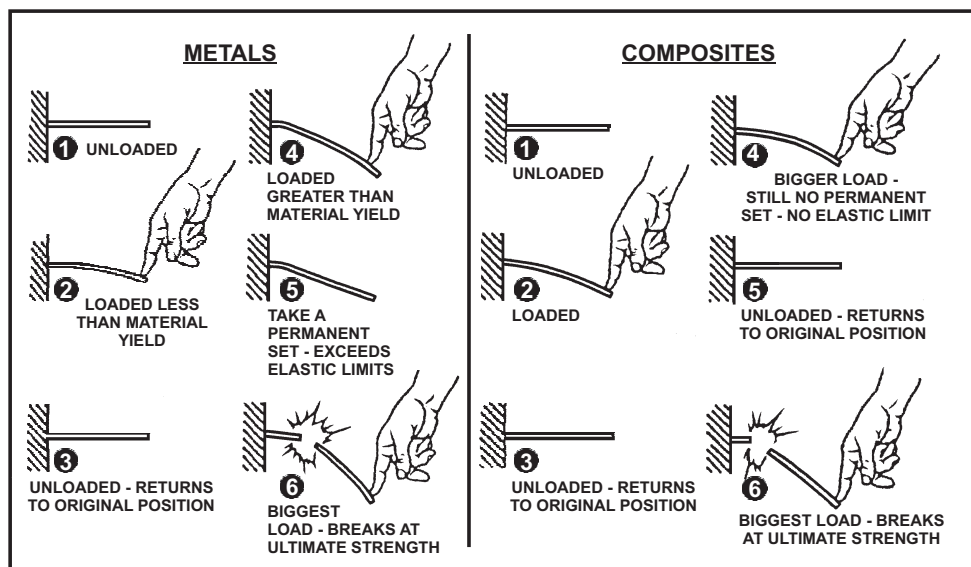

AM05022

Figure 5-22.—Response to applied loads.

The advantages of composites over metals are higher specific strengths, flexibility in design, ease of manufacturing, lighter weight materials, ease of repair (compared to metals), and excellent fatigue and corrosion resistance. The disadvantages are limited previous repair information, high start-up costs, difficulty of inspection, expense of materials, limited in-work times, poor impact resistance, sensitivity to chemicals and solvents, environmental attacks, and the low conductivity of the materials. Advanced composites are made up of fibers and the matrix.

Fibers are a single homogeneous strand of material, rolled or formed in one direction, and used as the principal constituent in composites. They carry the physical loads and provide most of the strength of composites. Composite materials are made up of many thousands of fibers arranged geometrically, woven or collimated (in columns). Some of these fibers are boron, graphite, and Kevlar®.

Boron Fibers

Boron was developed in 1959. Boron fibers are made by using a 0.0005-inch tungsten filament heated to about 2200°F and drawn through a gaseous mixture of hydrogen and boron trichloride. A coating of black boron is deposited over the tungsten filament. The resulting fiber is about 0.004 inch in diameter, has excellent compressive strength and stiffness, and is extremely hard.

Graphite Fibers

High-strength graphite fibers were not developed until the early 1970s. Fibers of graphite are produced by “graphitizing” filaments of rayon or other polymers in a high-temperature furnace. The fibers are stretched to a high tension while slowly being heated through a stabilization process at 475°F in ambient air. The fibers are carbonized at 2,700°F in an inert oxygen rich atmosphere, and the graphitization process takes place at 5,400°F in an inert atmosphere. Then the graphite fibers are subjected to a treatment process that involves cooling and cleaning of the carbon dust particles to improve the interlaminar shear properties. These shear properties relate to the shear strength between adjacent plies of laminate. The resulting fibers are black in color and only a few microns in diameter. They are strong, stiff, and brittle; through control of the process, graphite of higher tensile strength can be produced at the cost of lower stiffness. Aircraft parts are generally

produced with fibers of intermediate strength and stiffness.

Kevlar® Fibers

Kevlar® fibers are a registered trademark of E. I. DuPont de Nemours & Company Inc, which maintains exclusive production rights for the fibers. The structural grade Kevlar® fiber, known as Kevlar® is characterized by excellent tensile strength and toughness but inferior compressive strength compared to graphite. The stiffness, density, and cost of Kevlar® are all lower than graphite; hence, Kevlar® may be found in many secondary structures replacing fiber glass or as a hybrid with fiber glass. The fibers are golden yellow in color and measure .00047 inch in diameter.

Matrix

Although the fibers are the principal load-carrying material, no structure could be made without the matrix. The matrix is a homogeneous resin that, when cured, forms the binder that holds the fibers together and transfers the load to the fibers.

The most common matrix material in current use is epoxy. Epoxies provide high mechanical and fatigue strength; excellent dimensional stability, corrosion resistance, and interlaminar (between two or more plies) bond; good electrical properties; and very low water absorption. The changing of the matrix properties (hardening) by a chemical reaction is called the “cure.” Curing is the changing of the matrix properties (hardening) by a chemical reaction. Curing is usually accomplished with heat and vacuum pressure. The finished product may be a single-ply (lamina) or a multiply product called a “laminate.”

Laminate

A lamina is a single-ply arrangement of unidirectional or woven fibers in a matrix. A lamina is usually referred to as a “ply.” A laminate is a stack of lamina, or plies, with various in-plane angular orientations bonded together to form a structure. See figure 5-23. Drawings specify ply stacking angles and the sequence of the lay-up. A standard laminate orientation code is used to ensure standardization in the industry. The orientation code denotes the angle, in degrees, between the fibers and the “X” axis of the part. The “X” axis is usually spanwise of the part, or in the direction of applied loads. See figure 5-24. The laminate ply orientation or stacking sequence is

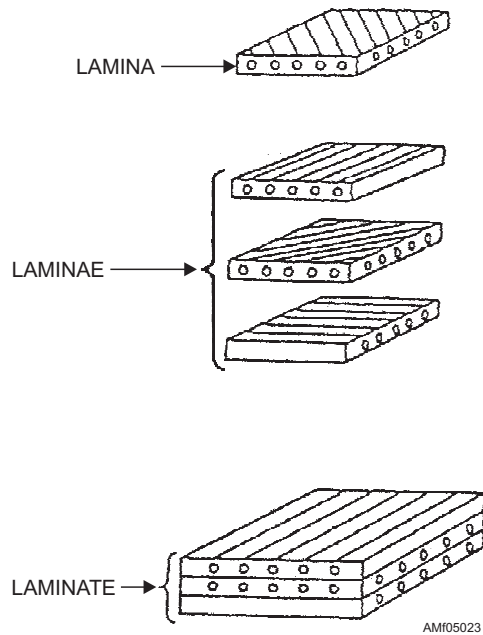

Figure 5-23.—Laminae stacking.

denoted in brackets, with the angle of each ply separated by a slash (/); for example, [+45/-45/+45/-45].

Laminae are listed in sequence from the first lamina to the last. The brackets or parenthesis indicate the beginning and the end of a code. The plus (+) and minus (-) angles are relative to the “X” axis. Plus (+) signs are to the left of 0, and minus (-) signs are to the right of 0. Adjacent laminae of equal angles but opposite signs are identified as \pm , ($\pm 45 = +45, -45$). The directional strengths and stiffness of the laminate can be altered by changing the ply orientation.

CATEGORIES OF COMPOSITE MATERIAL DAMAGE

Advanced composite materials continue to be increasingly popular with designers of new aircraft. It is estimated that new airframes will be 75 percent to 80 percent composites. As a structural mechanic, you will be required to maintain these new types of aircraft. To be proficient, you must be able to recognize the types of damage, understand the processes involved in damage assessment, inspection, and repair of composite materials. As new materials are introduced, new repair procedures will be required. It will be your responsibility to keep abreast of these developments.

Composite materials damage may be categorized as either environmental or physical. Environmental damage includes crazing and cracking caused by solar and ultraviolet radiation, water absorbed through humidity and rain, and lightning strike damage. Lightning strikes can cause holes to be burned in the structure, puncturing and splintering, and it has been known to weld bearings and hinges. Physical damage is caused by an applied force or deficiency in fabrication, such as dents, scratches, cracks, cuts and abrasions, pits, voids, disbonds, delaminations, core crush on sandwich structures, and impact damage.

ASSESSMENT OF COMPOSITE MATERIAL DAMAGE

The task of repair begins when you determined that the structure has been damaged and that the damage is sufficient to require the structure to be repaired. The

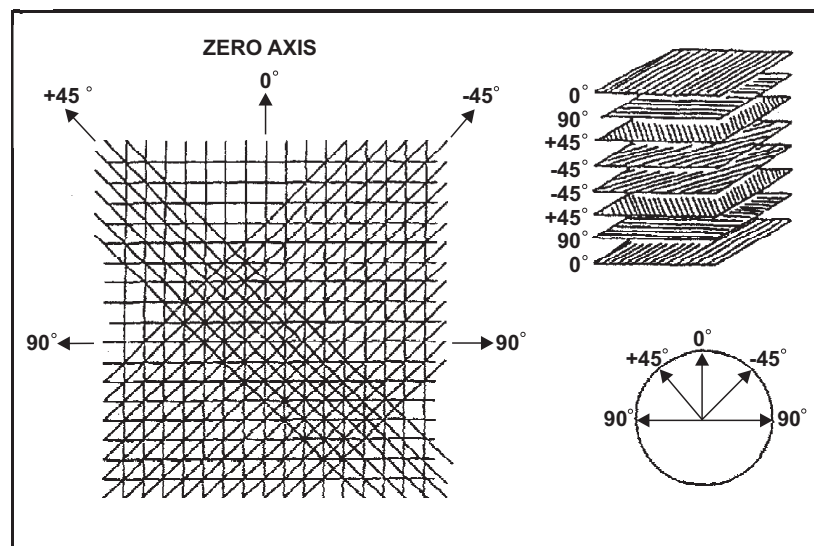

Figure 5-24.—Standard ply orientation clock.

existence of damage may be obvious, such as a skin penetration, a gouge, or a dent. Conversely, the proper identification and classification of the damage may be difficult. Because of the brittle, elastic nature of composite laminate materials, for example, the fibers may break upon impact, but then spring back, leaving little visible indication of damage.

There are three distinct steps involved in damage assessment. The first step is to locate the damage. The second step is to evaluate the defect to determine such information as the defect type, depth, and size. This information is important because the method of repair will vary, depending on this information. The third step is to re-evaluate, after defect removal (as applicable), the area being repaired.

DAMAGE INSPECTION METHODS

There are many methods available for locating and evaluating the damage. Ideally, the fastest method that will reliably find the appropriate type and size of defect should be employed since recurring costs will probably outweigh nonrecurring equipment procurement costs. Some of these inspection methods are visual inspection, tap test, X-ray, and ultrasonic inspections.

Visual Inspections

Visual inspections are a methodical search for defects, checking for obvious damages. Be suspicious of any nick, dent, or paint chip because there may be underlying damage. Many types of defects, such as impact damage, corrosion, and delamination, cannot be detected by visual inspections alone.

Tap Testing

A tap test is used in conjunction with a visual inspection, and is an elementary approach to locating delaminations, disbonds, core damage, water, or corrosion. Tapping should be done with a small hammer about the weight of a US 50-cent coin. A dull or dead sound indicates that some delamination or disbond exists. A clear, sharp sound indicates a solid structure. Tap testing is limited to finding defects close to the surface, and is ineffective in areas of sharp contours and changes in shape.

X-ray Inspections

X-ray inspections use the same basic process as a dentist uses to X-ray teeth. The penetrating power of the radiation is used to reveal the interior of objects and

to record it on film. Defects in material essentially change the thickness of the material, thus changing the degree of absorption of radiation. More radiation passes through the thinner area of a part, and shows up as a darkened area on the developed film.

Ultrasonic Inspections

Ultrasonic inspections use sound wave frequencies higher than the human hearing level, above 20,000 hertz, to penetrate the part. It measures the time the transmitted sound waves take to pass through the object and return to the receiver. The signals are changed into a display on a cathode-ray tube that provides a means of interpreting defects. Accurate results are dependent on an experienced operator, clean surface, known standards of part construction, and repeatability of indications.

- Q5-12. Advanced composite materials consist of a combination of what materials?*
- Q5-13. What type of inspection is used to analyze the extent of the damage and effectiveness of repair to composite materials?*
- Q5-14. What types of fibers are golden yellow in color and are used in many secondary structures replacing fiber glass or as a hybrid with fiber glass?*
- Q5-15. What is used as a single-ply arrangement of unidirectional or woven fibers in a matrix?*
- Q5-16. crazing and cracking of composite materials by ultraviolet radiation is categorized as what type of damage?*
- Q5-17. What type of damage inspection method is limited to finding defects close to the surface in composite materials?*
- Q5-18. What does a dark area on the developed film indicate when viewing an X-ray of composite materials?*

DAMAGE CLASSIFICATIONS

All damage must be classified to determine what repair action should be taken. Ultimately, all discrepancies will be placed into one of three categories—negligible damage, nonrepairable damage, or repairable damage. The decision concerning disposition must be made considering the requirements of the aircraft, the particular parts involved, the limitations that can be placed on the repaired aircraft,

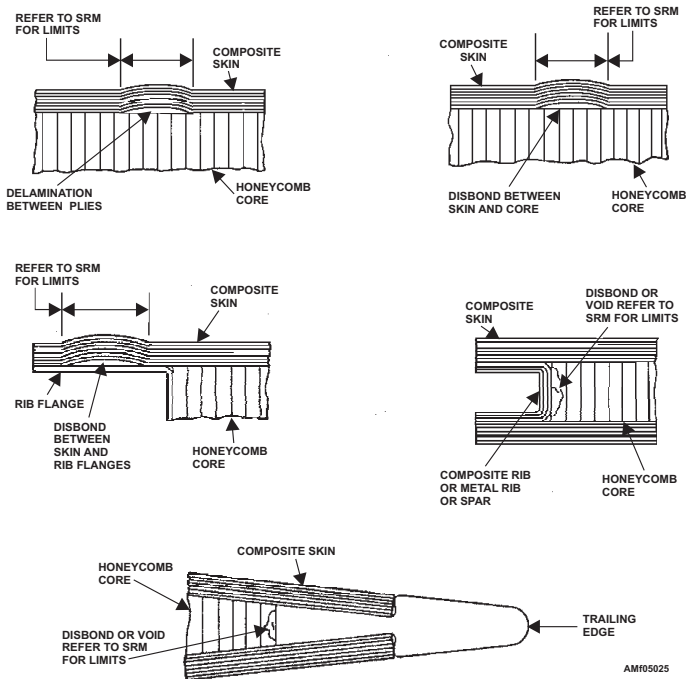

Figure 5-25.—Example of negligible damage on composite material.

the degree of urgency, and any other circumstances impacting the situation.

Negligible Damage

Negligible damage is damage that can be permitted to exist “as is,” or corrected by a single cosmetic refinishing procedure with no restrictions on flight operations. This damage may also include some delaminations, disbonds, and voids. See figure 5-25.

Nonrepairable Damage

Nonrepairable damage exceeds published criteria or limits. Nonrepairable damage may be reclassified as repairable, if cognizant engineering authority prescribes a repair on an individual basis. Normally, nonrepairable damage requires the changing of components.

Repairable Damage

Repairable damage is any damage to the skin, bond, or core that cannot be allowed to exist “as is” without placing performance restrictions on the aircraft. All permanent repairs must be structural, restore load-carrying capabilities, meet aerodynamic smoothness requirements, and meet the environmental durability requirements of the aircraft. See figure 5-26. Repairable damage is divided into several classifications. The aircraft's structural repair manual

(SRM) provides the approved repair procedures for all levels of maintenance. Information contained in the SRM includes damage classifications, inspection procedures, typical repair procedures, and tool and material lists. Damage exceeding any of these classifications require engineering disposition. The examples listed below may vary somewhat, depending upon the type of aircraft and the specific location of the damage on the aircraft.

- Class I Cuts, scratches, pits, erosion or abrasions not exceeding 0.005 inch in depth and 5 inches in length.
- Class II Damage with dents in the skin up to 3 inches in diameter and 0.01 inch in depth, with no delamination between skin plies, no cracks or graphite fiber breakage, or skin to honeycomb core separation.
- Class III Delaminations between plies, including the skin land area, opened up to external edge and up to 1 1/2 inches in diameter.
- Class IV Skin damage including delaminations, cracks, cuts, scratches or skin erosion exceeding 0.015 inch in depth, but less than full penetration, with no damage to honeycomb core.

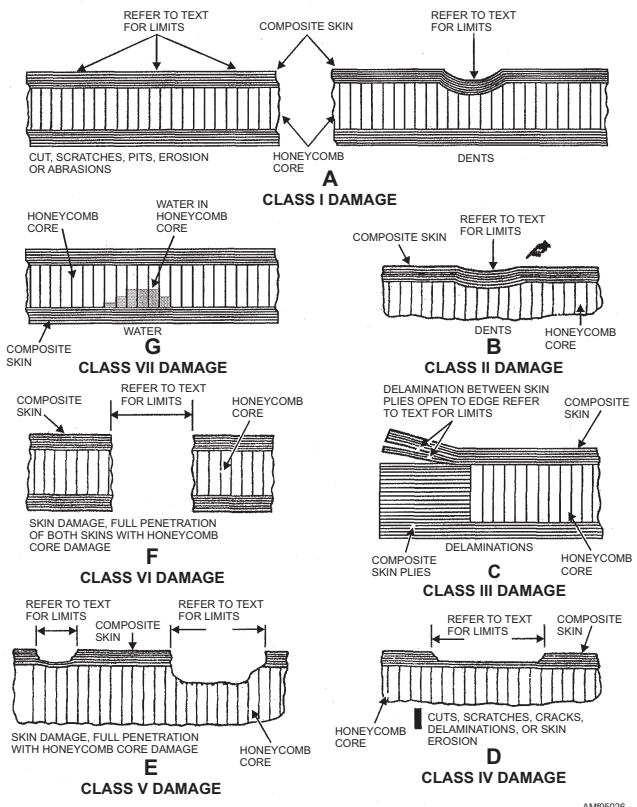

Figure 5-26.—Example of repairable damage on composite material.

- Class V Damage is single skin damage, including full penetration, accompanied with honeycomb core damage.
- Class VI Damage to both skins, including full penetration, accompanied with honeycomb core damage.
- Class VII Damage is water trapped in honeycomb area.

REPAIR CRITERIA

Repair criteria differ in the same way that initial design requirements for aircraft differ. Criteria for a repair can be less demanding if the repair is considered temporary. Temporary repairs are performed for such requirements as a onetime flight to a repair facility or one more mission under combat conditions. However, most repairs are intended to be permanent, and, except for special conditions, criteria are applied so that the repair will remain acceptable for the life of the aircraft.

One of the major factors that influence the repair quality is the environment where the repairs are to be made. For example, the presence of moisture is critical to bonded repairs. Epoxy resins can absorb 1.5 to 2 times their weight in moisture, thereby reducing the ability of the resins to support the fibers. Dirt and dust can seriously affect bonded repairs. Oils, vapors, and solvents prevent good adhesion in bonded surfaces and can lead to voids or delaminations. To perform quality repairs, personnel must have a knowledge of the composite system to be repaired, type of damage, damage limitations/ classifications, repair pub-

lications, materials, tools and equipment, and repair procedures.

The repair facilities where the work is to be performed will be clean and climate controlled if possible. The relative humidity should be 25 percent to 60 percent and temperatures stable at 65°F to 75°F. If repairs are to be made in an uncontrolled environment (hangar/flight deck), patches and adhesives will be prepared in a controlled environment and sealed in an airtight bag before being brought to the repair site.

Strength Restoration

Full strength repairs are desirable and should be made unless the cost is prohibitive or the facilities are inadequate. Less than full strength repairs are sometimes allowed on secondary structures that are lightly loaded, stiffness-critical structures designed for limited deflections rather than for carrying large loads (doors), or structures designed to a minimum thickness requirement for general resistance to handling damage (fuselage skins). Repair manuals for specific aircraft frequently “zone” the structure to show the amount of strength restoration needed or the kinds of standard repairs that are acceptable. Repair zones help to identify and classify damage by limiting repairs to the load-carrying requirements. Repair zone borders indicate changes in load-carrying requirements due to changes in the structure, skin thickness, ply drop-offs, location of supporting members (ribs and spars), ply orientation, core density, size and type of materials. Damage in one zone may be repairable, where as the same type of damage in an adjacent zone may not be repairable. See figure 5-27.

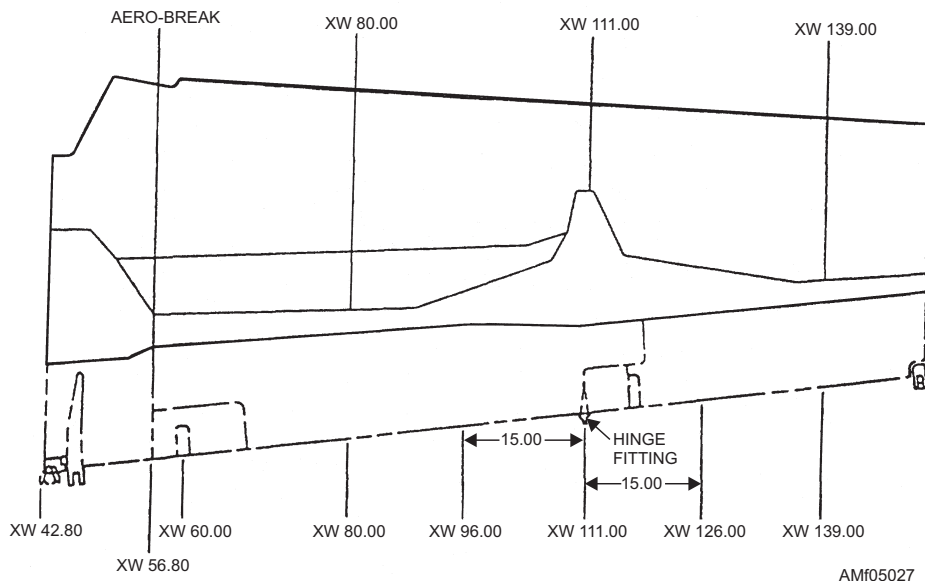

Figure 5-27.—Repair zones.

Aerodynamic Smoothness

High-performance aircraft depend on smooth external surfaces to minimize drag. During initial fabrication, smoothness requirements are specified, usually by defining zones where different levels of aerodynamic smoothness are required. These most critical zones include leading edges of wings and tails, forward nacelles and inlet areas, forward fuselages, and overwing areas of the fuselage. The least critical zones include trailing edges and aft fuselage areas.

Repair Tools

Drill motors should be capable of speeds of 2,000 to 5,000 rpm. These drills should be equipped with feed rate limiting surge controls to prevent backside breakout caused by feeding the drill too fast and excessive heat buildup from feeding the drill too slow. Feed rates should not exceed 30 seconds per inch, with 10 to 15 seconds per inch producing the best results on graphite-epoxy composites. The drill should be turning full speed prior to surface contact and during withdrawal from completed holes. These holes should be drilled slightly undersize and reamed to the required size. The various types of drill bits used for drilling composites are either twist, flat fluted/spade/dagger, single flute, or piloted countersink, and they are made out of carbide or carbon steel.

A drill stop (fig. 5-28) is an adjustable spring damper that is attached to the drill bit shank. This mechanically stops the drill at a predetermined depth prior to exiting the material backside, thus reducing backside breakout caused by the follow through. Firm pressure is required to overcome this spring tension for the drill to penetrate the laminates backside.

Routers are high-speed, hand-held, portable cutters used for removing damaged skin or core materials. They are designed to operate on shop air at speeds of 25,000 to 40,000 rpm. Routers are normally used with a template to define a smooth regular cut with the depth of the cut set and locked.

Hole saws are good for removing small areas of damage on laminates, although they have a tendency to damage honeycomb rather than cut it. Hole saws also easily clean up damages, providing a good surface for repairs. Backup plates should be taped to the backside of the material being sawed to prevent backside breakout. Fine tooth metal or diamond saws work the best for sawing laminates.

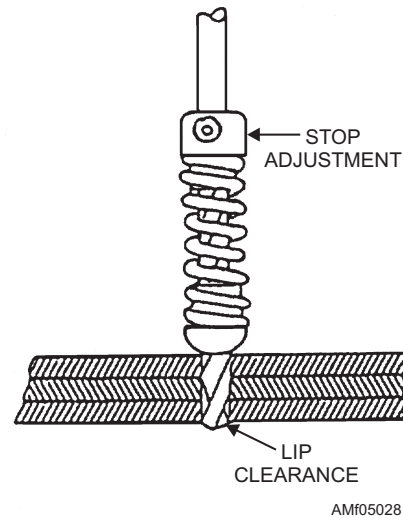

Figure 5-28.—Drill stop.

- Q5-19. "As is" damage is classified as what type of damage?
- Q5-20. Damage to the aircraft's skin that cannot be allowed to remain "as is" is classified as what type of damage?
- Q5-21. Where can you find information about structural damage classification, inspection procedures, typical repair procedures, and tool and materials lists?
- Q5-22. What is the classification of damage when water gets trapped in a honeycomb area?
- Q5-23. What enables you to identify and classify aircraft damage by confining the repairs to load-carrying requirements?
- Q5-24. What are the most critical zones in defining aerodynamic smoothness of control surfaces?
- Q5-25. What is a good tool for removing small areas of damage on laminates, although it has a tendency to damage the honeycomb core?

HAZARDS AND SAFETY PRECAUTIONS

LEARNING OBJECTIVE: Identify safety precautions peculiar to working with advanced composites materials.

The issue of personal health and safety is paramount when working with composite materials. With the rapid development of the new material systems, the full effect of hazards to personnel has not been determined; however, sensible shop practices and

procedures have to be employed to prevent problems now and those that may appear later. Following these safety precautions may prevent future health problems, such as those encountered in the case of asbestos fibers.

PERSONNEL HAZARDS

Airborne dust and fibrous particles are the principal source of hazards. These particles are generated by drilling, sanding, routing, or sawing the composite structures. Fine, lightweight fiber particles are easily circulated into the atmosphere, causing skin irritation and inflammation, eye irritation, respiratory system inflammation, pulmonary diseases (black lung), cancer of the lung, and abdominal disorders. Respiratory protection is required in those operations where dust exists or is generated. Eye protection, consisting of safety goggles or a face shield, is also recommended for use in work involving any operation where the likelihood of airborne fibers exist. Broken fibers can penetrate the skin. The fibers may become lodged beneath the skin. These fibers are so brittle and difficult to remove that they generally have to be cut out and the wound disinfected to prevent infections.

Personal hygiene includes washing your hands before and after working with composites, and your hair should be washed at the end of each day. Wash dust-contaminated clothing separate from other clothing. Do not eat, drink, or smoke in the composite repair area.

EQUIPMENT HAZARDS

Graphite dust and particles are conductors and can cause shorts in electrical motors and avionics circuitry. Also, these dust particles can affect the aircraft's fluid systems. In the hydraulic system where contamination is critical, actuating cylinder rods can draw the dust particles into the system, causing premature seal failures. The abrasiveness of these dust particles can also cause failures to valves, pumps, and other close tolerance parts. In the fuel system, these particles can be introduced during wet wing repairs, causing clogged filters and erroneous readings in capacitance fuel quantity probes. The abrasiveness of these dust particles can cause failures to fuel controls and other close tolerance fuel valves.

SOLVENTS

Because of the necessity to use solvents when accomplishing bonded repairs, you must give potential health and fire dangers special consideration.

Solvents dissolve natural skin oils and result in drying and cracking of the skin, rendering it susceptible to infection. Additionally, these solvents may cause irritation and allergic reactions to individuals. If the vapors are inhaled during prolonged and repeated exposure to moderate concentrations, solvents can cause headache, fatigue, nausea, or visual and mental disturbances. Extreme exposure may result in unconsciousness and even death. Solvent vapors may also act as an anesthetic or cause irritation of the eyes or respiratory system. In addition, they can result in blood, liver, and kidney damage. Therefore, adequate ventilation should be provided during mixing and use of adhesives, solvents, and cleaning solvents.

To minimize or eliminate the danger of fire and subsequent destruction of life and property, flammable solvents should be used only in approved areas and with methods recommended by local fire safety authorities. Composite material fire hazards are usually limited to solvents and resins. Flashpoints of solvents and resins vary, but are usually around 200°F or above.

High-temperature resins have higher flashpoints. Burning composite surface temperatures can exceed 1,000°F to 1,400°F and generate high internal combustion temperatures (830°F and above). Burning composites liberate dense smoke-drawing particles into the air, presenting hazards to personnel. Besides being hazardous to personnel, dust affects the quality of repairs. Bonding repairs will NOT be performed in the same area as machining operations. Vacuuming is used during all machining operations.

Some of the fire prevention and suppression requirements are as follows:

1. Eliminate all flames, smoking, sparks, and other sources of ignition from areas where solvents are used.
2. Use nonspark-producing tools.
3. Eliminate clothing that creates static electricity.
4. Solvents should be used in approved ways and stored in approved containers.
5. Ensure adequate ventilation where vapors are present.
6. Ensure aircraft and equipment are static grounded.
7. Composite materials produce hot fires. Combat fires with chemical foam, dry chemicals, CO₂, or low-velocity water fog.

8. Fight fires from the upwind position.
9. Wear self-contained breathing apparatus when fighting fires.

WASTE DISPOSAL

Carbon or graphite fibers cannot be disposed of by incineration. All composite material particles and dust must be packaged, tagged, and buried in an approved landfill. Do not allow fibers to contaminate water supplies.

Coolants used in machining composites also contain fibers and particles. When disposing of these particles, allow them to remain still so they will settle to the bottom, drain off the liquid without disturbing the particles, and then bag and dispose of them properly.

- Q5-26. *What type of dust and particles are conductors, can cause shorts in electrical equipment, and contaminate hydraulic systems?*
- Q5-27. *When making bonded repairs, what materials present health and fire hazards to personnel?*
- Q5-28. *What types of composite material particles and dust cannot be disposed of by burning and must be packaged, tagged, and buried in an approved landfill?*

AIRCRAFT PAINTING

LEARNING OBJECTIVE: Identify the procedures and equipment used in preparing and painting aircraft structures, surfaces, or components.

The primary objective of any paint finish is to protect exposed surfaces against corrosion and other forms of deterioration; however, there are other reasons for paint schemes. The reduction of glare, the reduction of heat absorption, camouflage, high visibility requirements, and identification markings are also objectives of a paint finish.

You will do some touchup painting because paint schemes are continuously used during the maintenance process. The publications related to aircraft painting are *Finishes, Organic, Weapons Systems*, MIL-F-18264D(AS), and *Paint Schemes and Exterior Markings for U.S. Navy and Marine Corps Aircraft*, MIL-STD-2161(AS).

You should not repaint aircraft for the sake of cosmetic appearance only. A faded or stained but

well-bonded paint finish is better than a fresh touchup treatment applied over dirt, corrosion products, salt spray, or other contaminants. Refinishing should be restricted to areas where the existing paint finishes are damaged or deteriorated. Because of age or exposure, some finishes fail to perform their protective function. The maintenance and repair of paint finishes is important. It begins when the aircraft is received and continues, with constant surveillance, throughout the service life of the aircraft.

TOUCHUP PAINTING

Touchup painting is the repairing of small areas where the paint has been worn or removed because of corrosion, weathering, or erosion. The paint system may consist of a primer, a compatible topcoat, or a combination of primer and compatible topcoat. A paint scheme is the arrangement and description of the paint system. A topcoat is the finish coating material used over the primer. A primer is a base coat that improves adhesion and inhibits corrosion.

Paint systems are identified by a decal or stencil located on the right side of the aft fuselage. All touchup and paint system maintenance procedures should be performed according to the local maintenance instructions and *Aircraft Weapons Systems Cleaning and Corrosion Control*, NA 01-1A-509. To touch up avionics equipment, you should refer to *Avionic Cleaning and Corrosion Prevention/Control*, NA 16-1-540. The touchup of ground support equipment is covered in *Ground Support Equipment Cleaning and Corrosion Control*, NA 17-1-125.

Aircraft radomes, walkways, and leading edges require special coatings to satisfy service exposure requirements. Radomes and parts with similar elastomeric coatings should be repaired according to *Aircraft Radomes and Antenna Covers*, NA 01-1A-22. If the damage is beyond the limits specified, you should replace the component and send the damaged part to the next higher maintenance level for repair.

Containers used to hold paints, lacquers, removers, thinners, cleaners, or any volatile solvents should be kept tightly closed when not in use. They should be stored in a separate building or fire-resistant room that is well ventilated. The paint material should not be exposed to excessive heat, smoke, sparks, flame, or direct rays of the sun. Wiping rags and other flammable waste material should always be placed in tightly closed metal containers. Waste containers should be emptied at the end of each day's work.

SURFACE PREPARATION

The effectiveness and adherence of a paint finish depend upon careful surface preparation. Before you begin to paint, you should remove all soils, lubricants, and preservatives from the surface. You should treat corroded areas and replace defective seam sealants. Corrosion control is covered in the *Aviation Maintenance Ratings*, NAVEDTRA 14022.

Paint Removal

Paint removal should be accomplished by the mildest mechanical or chemical means. Paint removal operations at the organizational and intermediate maintenance levels are usually confined to small areas. Whenever you use paint remover, the procedures outlined in the applicable MIM should be observed. General stripping procedures are contained in *Aircraft Weapons Systems Cleaning and Corrosion Control*, NA 01-1A-509.

Materials

All paint removers are toxic and caustic; therefore, both personnel and material safety precautions must be observed in their use. You should wear eye protection, gloves, and a rubber apron.

MIL-R-81294 paint remover is an epoxy. This remover will strip acrylic and epoxy finishes satisfactorily. Acrylic windows, plastic surfaces, and rubber products are adversely affected by this material. This material should not be stocked in large quantities because it ages rapidly and degrades the results of stripping action.

Additional paint removers are discussed in NA 07-1-503. Each remover has a specific intended use. For example, MIL-R-81294 is used for removing epoxy finishes, but it may be damaging to synthetic rubber, while another nonflammable water soluble paint remover conforming to MIL-R-18553 is usable in contact with synthetic rubber. In all cases, you should use the remover that meets the requirements of the job.

General Procedures and Precautions for Stripping

General stripping procedures are described in this section. When you are stripping an aircraft surface, you should consult the applicable MIM for the specific procedures to be used.

CAUTION

Prior to cleaning and stripping, you should ensure the aircraft is properly grounded to dissipate any static electricity produced by the cleaning and stripping operations.

Stripping should be accomplished outside whenever possible. If stripping must be done in a hangar or other enclosure, you must have adequate ventilation.

Paint remover may contact adhesives at seals, joints, skin laps, and bonded joints. In these areas you should mask with approved tapes and papers.

Stripper should be applied liberally with a fiber brush. You should completely cover the surface to a depth of one thirty-second to one-sixteenth of an inch. The stripper should not be spread in a thin coat. A thin coat will not sufficiently loosen the paint. If the coat is too thin, the remover may dry on the surface of the metal.

You should allow the stripper to wrinkle and lift the paint. This may take from 10 minutes to 40 minutes, depending upon the temperature, the humidity, and the condition of the paint.

You should remove loosened paint and residual paint remover by washing and scrubbing the surface with fresh water, nonmetallic scrapers, fiber brushes, or abrasive pads. If water spray is available, use a low- to medium-pressure stream of water directly on the surface while it is being scrubbed.

After you thoroughly clean the surface, you should remove the masking materials and remove any residual paint.

Rinse the surface with a freshwater and alkaline solution (1 part MIL-C-25769 to 9 parts water) to neutralize the paint remover.

FLAP BRUSH.—Paint can be mechanically removed with a flap brush. The brush consists of many nonwoven, nonmetallic nylon flaps bonded to a fiber core. The brush assembly (fig. 5-29) is made up of a flap brush, flanges, and a mandrel. It should be operated by a NO LOAD, 3200-rpm, pneumatic drill motor. The direction of rotation is indicated by an arrow imprinted on the side of the core. When a flap brush has been worn down to within 2 inches from the center of the hub, you should replace it. Continued use beyond this limit may cause gouging due to loss of flexibility of

the fiber. When you use a flap brush, apply minimum pressure to remove the maximum amount of paint and the minimum amount of metal. Excessive pressure will cause some paints to melt, gum up, and streak. Eye protection should be worn when you are operating a flap brush.

SCUFF SANDING.—Aged paint surfaces should be scuff sanded to ensure the adhesion of the overcoating paint. Scuff sanding is the roughening of a paint surface as evidenced by a significant reduction of the gloss. To scuff sand, you should use aluminum oxide cloth, abrasive mats, or an oscillating sander with aluminum oxide cloth. Scuff sanding to a depth greater than necessary may result in complete removal of the paint. This situation will expose the underlying metal, and corrosion may develop. Unevenly matched faying surface joints or fasteners and sharply protruding objects or corners should be scuff sanded by hand to avoid sanding through the paint. After sanding, you should remove the residue with a clean, cotton cheesecloth dampened with MIL-T-81772 thinner.

PAINT FEATHERING.—You should feather the paint along the edge of an area that has been chemically stripped to ensure a smooth, overlapping transition between the old and new paint surfaces. The smooth overlapping paint film will prevent soil from accumulating in the junction between the old and new paint films. Feathering should be accomplished with 280 or 320 grit aluminum oxide cloth or a flap brush.

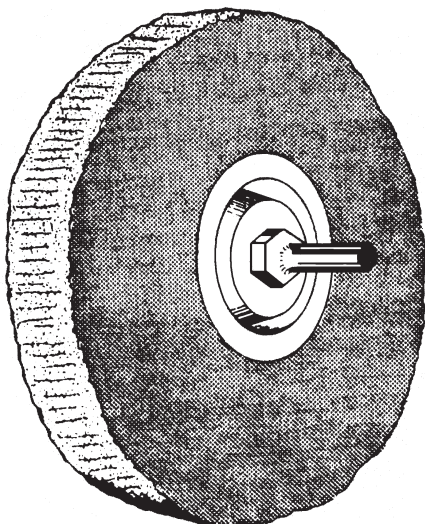

AMF05029

Figure 5-29.—Flap brush with mandrel.

The major portion of thick paint films may be removed with an oscillating sander with 240 or finer grit aluminum oxide cloth. Do not allow the oscillating sander to touch bare metal. The contact between an operating sander and bare metal will damage the metal, which, in turn, may cause future corrosion. The oscillating sander should not be used after first indications of primer exposure. You should use a flap brush or hand-held 240 grit or finer aluminum oxide cloth for final feathering operations.

TREAT AND SEAL.—Chemical conversion treatment is an extremely important part of the corrosion control process. Properly applied chemical treatments impart corrosion resistance to metal. It also improves the adhesion of the paint system. You should use chemical conversion coating materials according to the procedures outlined in the NA 01-1A-509.

First, you should remove all loose seam sealants in the area to be touched up. Replace them as necessary. You should also secure loose rubber seals with the type of adhesive specified in the applicable MIM.

The area to be painted should be outlined with tape and masking paper, as shown in figure 5-30. This protects the adjoining surfaces from overspray and paint buildup.

TOUCHUP PROCEDURES

A standardized paint system for organizational and intermediate level painting and paint touchup has been developed by the Naval Air Systems Command. Standardized exterior paint touchup consists of an

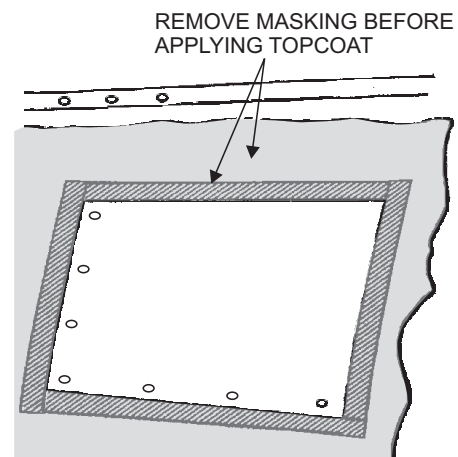

AMF05030

Figure 5-30.—Masking prior to paint touchup.

epoxy primer (MIL-P-23377, type I or type II) overcoated with aliphatic polyurethane (MIL-C-81773 or MIL-C-83286) or alternate paint system. Paint systems are identified by a decal or stencil located on the right side of the aft fuselage.

Standardized interior paint touchup systems consist of TT-P-1757 zinc chromate primer. Paint materials that are within their original shelf life or within an extended shelf life are preferred. However, if materials are beyond shelf life date, you should test them on a small sample of scrap aluminum.

Epoxy-Polyamide Primer MIL-P-23377

The epoxy-polyamide primer is supplied as a two-part kit. Each part must be stirred or shaken thoroughly before mixing. One component contains the pigment in an epoxy vehicle, while the other component consists of a clear polyamide used as a hardener for the epoxy resin. These components are packaged separately and have excellent storage stability. However, when the two parts are mixed, the pot life is limited to 8 hours. Only the amount that you can use in 8 hours should be mixed. The established mixing ratios must be followed closely, otherwise poor adhesion, poor chemical resistance, or inadequate drying may result. The clear polyamide hardener should always be added to the pigmented component.

CAUTION

Do not mix components from different manufacturers.

The mixed epoxy-polyamide primer can be thinned to obtain the proper viscosity for spraying. However, you should check the local air pollution regulations for restrictions and regulations regarding the use of certain solvents and thinners.

To spray epoxy-polyamide primer, you should thin it with MIL-T-81772, type II (preferred) or type I. The thinned primer should be stirred thoroughly, strained, and allowed to stand for a minimum of 15 minutes prior to spraying it. The thinning ratio may vary to obtain the proper spraying viscosity, which is 17 to 18 seconds in a No. 2 Zahn cup. The 15-minute standing time permits the components to enter into chemical reaction, reduce cratering, preclude the clear resin component from "sweating out" or separating, and to allow any bubbles (formed while stirring) to escape.

WARNING

You should wear goggles when mixing or using thinners and solvents. You should also wear goggles or a face shield, respirator, rubber gloves, and coveralls during all paint touchup and paint spraying. Eating, drinking, or smoking should NOT be allowed in areas where paint or solvent is being used or stored.

Before you apply the primer, ensure that the surface has been cleaned, chemically treated, and prepared for spraying. Then, apply a cross coat of epoxy-polyamide primer and allow the coat to air dry for 1 hour. The total dry film thickness of primer should be 0.6 to 0.9 mil. If the temperature is below 70°F, you should allow 2 to 3 hours for drying. Do not spray if the temperature is below 50°F.

Polyurethane Paint Systems

All personnel assigned duties involving the mixing and application of polyurethane coatings should receive a preplacement and periodic medical evaluation. The date and results of each medical evaluation should be entered on the Administrative Remarks page of the individual's service record and in the individual's training jacket.

The polyurethane systems used on naval aircraft consist of two types. The aliphatic type is used in MIL-C-83286 polyurethane paints. The aromatic type is used in MIL-C-85322 rain erosion-resistant coatings. These materials generally present no special hazard to health when they are cured (dried). They do require special precautions during their preparation, application, and curing because isocyanate vapors are produced. The untreated isocyanates released can produce significant irritation to the skin, eyes, and respiratory tract even in very small concentrations. They may also induce allergic sensitization.

MIL-C-83286 aliphatic polyurethane is the standard general-purpose exterior protective coating for aircraft surfaces. Its unique combination of flexibility, gloss retention, and resistance to fuels and lubricating oils make the coating extremely suitable for aircraft exterior surfaces. It is supplied as a two-component kit of base and catalyst. You should use aliphatic polyurethane over epoxy-polyamide primer and for touchup and insignia marking over polyurethane paint systems.

All personnel using polyurethane touchup operations should wear protective clothing as described in NA 01-1A-509. Unprotected personnel should not be permitted closer than 15 feet to the spray zone during paint application with a brush, roller, or spray equipment. They should be permitted no closer than 40 feet during applications with compressed-air spray. Unprotected personnel should not be permitted closer than 15 feet to newly painted surfaces for 30 minutes after the painting operation is completed unless forced air exhaust ventilation is being used.

Aliphatic polyurethane paint is available in kits consisting of 1 part pigmented material and 1 part clear resin component. When you mix aliphatic polyurethane paint, the clear resin component should always be added to the pigmented component. Only material from the same kit should be mixed together. However, two or more kits of the same color and manufacturer may be mixed in the same vessel. You should not mix clear resin components and pigmented components from different manufacturers. You should also follow the prescribed mixing ratios to prevent long drying times, poor chemical resistance, or loss of flexibility. You should use a mechanical shaker to agitate the pigmented component for at least 20 minutes. Then add the clear resin slowly to the pigmented component while you are stirring the pigmented component. Ensure the pigmented component and clear resin are thoroughly mixed. You should mix only the amount of paint that you can use in the 4-hour pot life of the mixed paint. When painting with polyurethane paints, you should clean the paint gun at the end of each use or every 4 hours, whichever comes first.

To spray aliphatic polyurethane paint, you should thin it with MIL-T-81772 to the desired spray viscosity. Then stir the mixture, strain it through cheesecloth, and allow it to stand for a minimum of 15 minutes. If the viscosity of the mixed paint is too thick for spraying within 3 hours after mixing, it may be thinned again by adding MIL-T-81772 thinner. You should not attempt to rethin paint after 3 hours because it tends to produce orange peel or dry spots.

Aliphatic polyurethane paint should be applied over a clean epoxy-polyamide primer within 8 hours of primer application. For the best results, you should apply the topcoat as soon as the primer is dry. You should apply the minimum thickness required to hide the primer. Apply two thin, wet coats about 30 minutes apart. Do not apply a mist coat because it may cause a low gloss. A primer or topcoat that has aged longer than 24 hours should be scuff sanded and cleaned before it is

painted. You should allow approximately 8 hours for painted surfaces to dry. Additional time, usually 1 or 2 hours, will be required if the temperature is below 70°F.

During the application of an aliphatic polyurethane topcoat, certain discrepancies may appear on the finish because of faulty application methods. The most common defects, probable causes, and preventions are listed in NA 01-1A-509. If any of these defects are found, they should be corrected before you continue to paint.

Du Pont Teflon® Filled Polyurethane Paint

This paint is a two-component, filled polyurethane paint system. When properly applied, it provides superior abrasion resistance, chafe and erosion resistance, and toughness, flexibility, gloss, and color retention. It is applied primarily to the leading edges of aircraft.

The Du Pont Teflon® filled polyurethane paint is prepared by thoroughly mixing each of the components separately. The base component (pigmented) should be mixed with a mechanical paint shaker for 30 minutes. Before you add the hardener, the pigmented base should be strained through a wire screen (No. 18 testing sieve). Be sure you crush the lumps with a mixing stick. One part 10-C-170 hardener (clear) is then slowly added to 1 part 4X203 base component. Stir constantly. Immediately after you add the hardener, add MIL-T-81772 thinner as necessary to achieve a viscosity of 20 to 25 seconds with a No. 2 Zahn cup. The pot life of the mixed material is 2 hours at a room temperature of 70°F to 75°F (21.1°C to 23.9°C). Do not use the mixed material over 2 hours after catalyst addition.

Just prior to priming, you should wipe the area with a lint-free cloth and MIL-T-81772 thinner. Use the “two-rag” technique. Wipe with a solvent-laden rag and immediately follow it with a dry rag. The use of a dry tack rag for removing lint is permissible. This solvent wipe should not be considered as part of the primer application for the purpose of time-after-chemical treatment.

After the surfaces have been prepared, you should apply the epoxy primer. Do not attempt to apply a heavy or full-hiding coat. The proper thickness (dry film of 0.6 to 0.9 mil) is obtained at the point where the film is wet but retains a translucent appearance. You should allow the epoxy primer to air dry for a minimum of 2 hours.

After the primer has cured, apply the first coat of Du Pont Teflon® filled polyurethane paint as a thin wet coat approximately 0.6 of an inch thick (tack coat). Do not dry mist or flood the first coat.

Allow a minimum of 30 minutes for the solvent to flash off the first coat, and then apply a full wet coat (1.5 to 2.0 mils). Allow an additional 30 minutes to cure. Repeat the application process until a topcoat dry film thickness of 5 to 6 mils is obtained. Allow the complete system to cure overnight. The full cure takes 7 to 10 days at 70°F to 75°F (21.1°C to 23.9°C).

Epoxy-Polyamide MIL-C-22750

Epoxy-polyamide is an alternate material for aliphatic polyurethane. The epoxy-polyamide topcoat is a two-component kit. One part of the kit contains a pigmented component; the other part of the kit contains clear resin. The pigmented component and clear resin are mixed in a one-to-one ratio prior to use. The local air pollution regulations, mixing, thinning and application instructions for MIL-C-22750 epoxy-polyamide topcoat are identical to those for aliphatic polyurethane with the following exceptions: The stand time after mixing is 30 minutes, and it should be thinned with MIL-T-81772 (preferred) or MIL-T-19544 (alternate). You should allow the thinned paint to stand for a minimum of 30 minutes before it is used. The total mixing, thinning, and stand time should not exceed 1 1/2 hours. The time between coats should be about 30 minutes, and the temperature during application should not be less than 50°F. The application of epoxy-polyamide is not limited by relative humidity or high temperatures.

Acrylic Nitrocellulose Lacquer

MIL-L-19537 (gloss) and MIL-L-19538 (camouflage) acrylic nitrocellulose lacquers are the preferred topcoat materials for aircraft markings and propeller safety stripes. MIL-L-19538 is also used for paint touchup of avionic components and instruments.

You may thin MIL-L-19537 or MIL-L-19538 to a spraying viscosity by thoroughly mixing 1 part of lacquer with approximately 1 part of MIL-T-19544 thinner (preferred) or MIL-T-81772 thinner (alternate). The exact thinning ratio should be determined by the user and adjusted to the temperature, relative humidity, and spraying equipment. Acrylic nitrocellulose lacquer that has been thinned to spraying viscosity should be applied to a thickness of 1 to 2 mils. Acrylic nitrocellulose lacquer with an aerosol container may

require three to four coats to cover the primer. A 5 to 10 minute air-drying interval should be allowed between coats. Apply only the minimum thickness required to cover the primer coat and allow 1 hour to dry.

Zinc Chromate Primer TT-P-1757

Zinc chromate primer is intended for use as a general-purpose interior protective coating for metal surfaces. Depending on the location, zinc chromate primer may or may not require a topcoat. Primer is relatively easy to apply and remove. Zinc chromate primer is a single component. You should thin primer with TT-T-548 toluene or TT-M-261 methyl ethyl ketone. Do not use zinc chromate primer on exterior aircraft surfaces, wheel wells, wing butts, or in areas that are exposed to temperatures exceeding 175°F (79.4°C).

Enamel Finishes

Most enamel finishes used on aircraft surfaces are baked finishes that cannot be touched up by organizational or intermediate levels of maintenance. Minor damage to conventional enamel finishes ordinarily used on engine housings is repaired with epoxy topcoat material or air-drying enamel.

Elastomeric Rain Erosion-Resistant Coating MIL-C-7439

Elastomeric coatings are used as a coating system to protect the exterior laminated plastic parts of high-speed aircraft, missiles, and helicopter rotor blades from rain erosion. They offer good resistance to the effects of weather and aromatic fuels. Excellent adhesion is obtained after a 7-day-drying period.

Repairs to these coatings in the field are impracticable because of the long curing time. Kits are available to repair coatings where limited touchup is required. These kits contain a primer, neoprene topcoat, and antistatic coating. If the radome or leading edge coatings are in bad condition, they should be stripped completely and recoated with epoxy primer and acrylic topcoat as a temporary measure. If schedules and conditions permit adequate curing of elastomeric coatings, these original coatings may be replaced.

The repair kits are normally bought open purchase to ensure that fresh materials are available. They should be stored in a cool place or refrigerated. Heat accelerates their aging. Stripping fiber glass surfaces should be done according to the current maintenance

instructions. Elastomeric coatings are toxic and flammable and must be used with care.

General Safety Precautions for Painting

General safety precautions for all painting as well as those for special types of paints must be observed. These precautions include the following:

- No eating, drinking, or smoking is allowed in areas where paint or solvent is being used.
- Prolonged breathing of vapors from organic solvent or materials containing organic solvent is dangerous. Prolonged skin contact with organic solvents or materials containing organic solvents can have a toxic effect on affected skin areas.

- Q5-29. *What is the primary objective of any paint finish?*
- Q5-30. *How can you identify the paint system of an aircraft?*
- Q5-31. *By what means should chemical or mechanical paint removal be accomplished?*
- Q5-32. *What appearance should chemical paint stripper have that indicates the paint is ready to be removed?*
- Q5-33. *What treatment is an extremely important part of the corrosion control process?*
- Q5-34. *What is the pot life of Epoxy-polyamide primer once the two parts are mixed?*
- Q5-35. *What type of evaluation should all personnel receive prior to being assigned duties involving the mixing and application of polyurethane paint system coatings?*
- Q5-36. *What is the closest distance that unprotected personnel should be allowed to newly painted surfaces upon completion of the painting operation?*
- Q5-37. *For excellent adhesion, what is the drying period for Elastomeric rain erosion-resistant coating?*

PAINTING SPECIFICATIONS

Specifications for the location, colors, and layout for letters and numbers can be found in *Paint Schemes and Exterior Markings for U.S. Navy and Marine Corps Aircraft*, MIL-STD-2161(AS). Other painting specifications that you may need to perform your duties are *Finishes, Organic, Weapons Systems,*

MIL-F-18264D(AS); and Marking and Exterior Finish Colors for Airplanes, MIL-M-25047C(ASG).

Numbers and Letters

The layout for standard military letters and numbers is shown in figure 5-31. The specifications of the form for letters follows:

The width of all letters and numbers is measured across the greatest distance from the outermost points of the letters or numbers. The width of the letters and numbers is calculated according to a percentage of the height by the number of blocks the figure represents. In other words, to obtain the percentage of the height, divide the width of the figure by the height.

Examples:

1. The letter *N* is 6 blocks high, as are all the figures, and 4.5 blocks wide; therefore, the width of the letter should be 75 percent of the height.
2. The letter *A* is 5.5 blocks wide, therefore, the width should be 92 percent of the height.
3. The letter *W* is 6.5 wide; therefore, the width should be 108 percent of the height.

The sides of some letters and numerals should be made to include an angle of 30 degrees with the tops or bottoms, as shown in figure 5-31. The space between

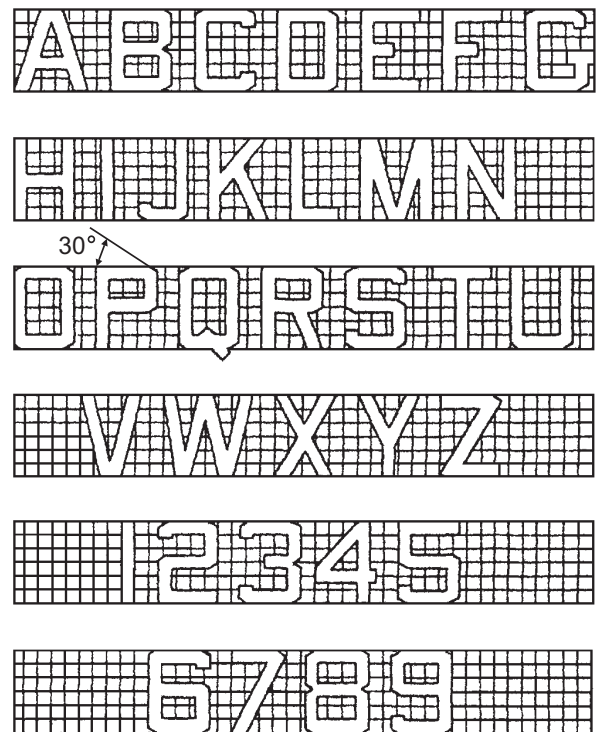

AM05031

Figure 5-31.—Forms of letters and numerals.

the letters and numerals is constant. It is always one-sixth of the height of the letter or numeral. This distance is always measured from the point on each of the letters or numerals that is nearest the other.

National Insignia

The national insignia consists of a white, five-pointed star inside a blue circumscribed circle. A white rectangle, one radius of the blue circle in length and one-half the radius of the blue circle in width, is located on each side of the star. The top edges of the rectangle form a straight line with the top edges of the horizontal two-star points beneath the top start point. A red horizontal stripe one-sixth of the radius of the star is centered in the white rectangles at each end of the insignia. A blue border, one-eighth the radius of the blue circle in width, outlines the entire design. When the insignia is applied on a sea blue, dark blue, or black background, the blue circle and border may be omitted. The inside edge of each interior rectangle is concave and has the same arc as the inside blue circle. The inside edge of each outer rectangle should not be depicted. See figure 5-32. You may refer to MIL-STD-2161(AS) for more information on the national insignia.

Tactical Paint Schemes

Tactical paint schemes are used for deception, for reduction of detection range, or to confuse and mislead observers. Tactical paint scheme patterns are applied to an aircraft to lessen the probability of visual or photographic detection. This applies to an aircraft that is in flight or on the ground. The patterns are based on optical principles and use nonreflective colors, color configurations, and color proportions. Arbitrary applications of markings and color schemes will reduce the effect of tactical paint schemes and should not be used. All tactical paint schemes should comply with *Paint Schemes and Exterior Markings for U.S. Navy and Marine Corps Aircraft*, MIL-STD-2161(AS), and *Finishes, Organic, Weapons Systems*, MIL-F-18264D(AS). Tactical paint schemes are usually comprised of either two or three shades of gray or blue.

The standard material for the tactical paint scheme coating system and common insignia and marking application is lusterless MIL-C-83286 aliphatic polyurethane. Decals may be used instead of paint for insignia and markings provided they are made of a

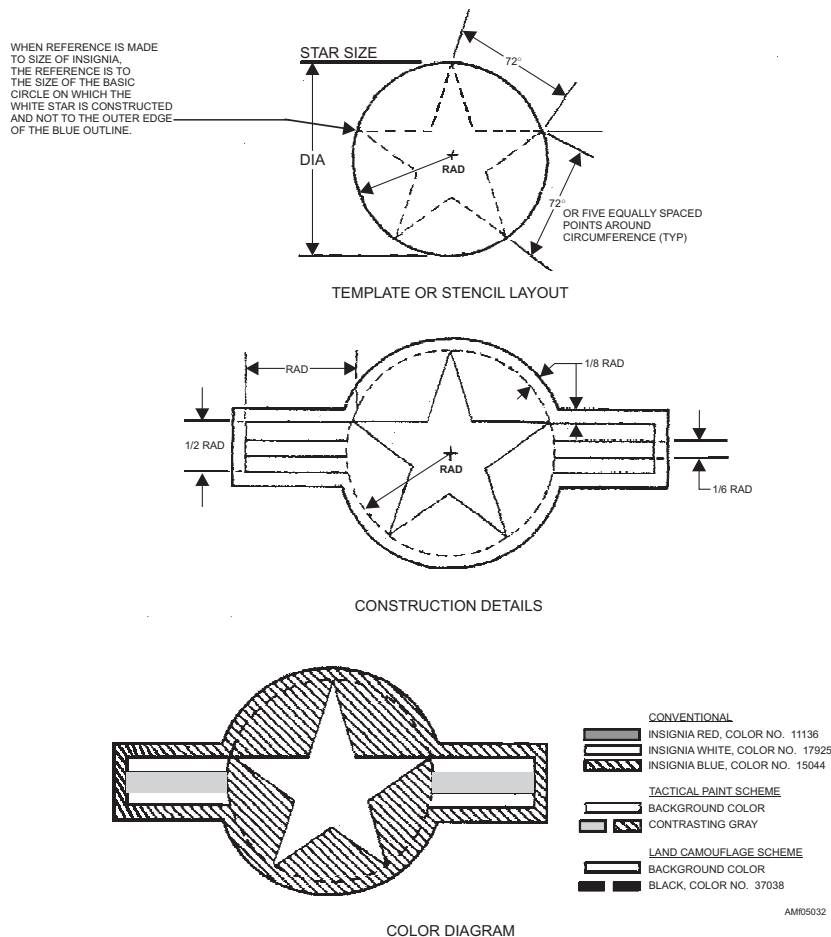

Figure 5-32.—National star insignia.

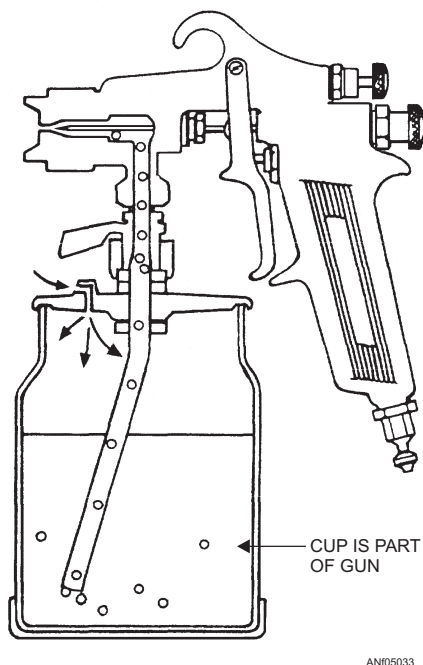

Figure 5-33.—Suction-feed spray gun.

nonreflective material and meet the gloss requirements of the coating system. Decals should not be used to apply large markings, such as the national insignia. The use of MIL-C-83286 is not required to apply aircraft unit markings.

PAINTING EQUIPMENT AND MAINTENANCE PROCEDURES

The equipment and techniques used to paint aircraft are covered here. You will frequently use and maintain spray guns, air compressors, and regulators.

Spray Guns

The spray gun atomizes the material to be sprayed. You direct and control the spray pattern by

manipulating and adjusting the spray gun. Spray guns are usually classed as either suction feed or pressure feed. The types are divided by two methods—the type of container used to hold the paint material and the method in which the paint is drawn through the air cap assembly.

SUCTION FEED.—The suction-feed spray gun is designed for small jobs. The container for the paint is connected to the spray gun by a quick-disconnect fitting, as shown in figure 5-33. The capacity of this container is approximately 1 quart. The fluid tip of this type of spray gun protrudes through the air cap, as shown in figure 5-34. The air pressure rushing past the fluid tip causes a low-pressure area in front of the tip. This causes paint to be drawn up through the fluid tip, where it is atomized outside the cap by the air pressure.

PRESSURE FEED.—The pressure-feed spray gun is designed for use on large jobs where a large amount of spray material is to be used. The spray material is supplied to the gun through a hose from a pressurized tank. This spray gun is designed to operate on high-volume, low-pressure air. This type of equipment eliminates the evaporation of the volatile substances of the mixture before striking the surface because the paint and air are mixed in the tanks. In other words, a wetter coating is applied.

Spray Gun Maintenance

Fluid leakage at the front of the gun is an indication that the fluid needle is not seating properly. This may be caused by a fleck of dried material in the nozzle, or the fluid needle packing may be too tight. It may also be caused by a bent fluid needle, a broken fluid needle spring, or the wrong size fluid needle for the fluid tip.

Air leakage results from an improperly set air valve. This may be caused by a bent valve stem, broken spring, or damaged valve or valve seat.

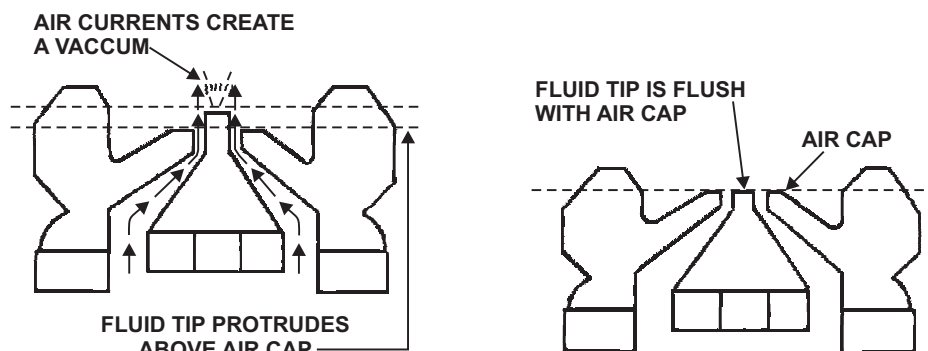

Figure 5-34.—Suction and pressure fluid tips and air caps.

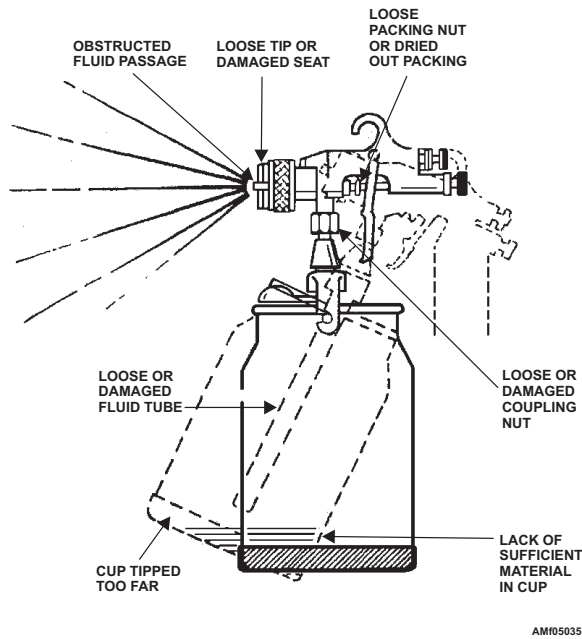

Figure 5-35.—Causes of jerky or fluttering spray.

Jerky or fluttering spray is caused by an obstructed fluid passage, loose tip, damaged seat, or air in the fluid line. Air can be inducted into the line from several

sources: a loose packing nut, dried packing, loose or damaged coupling nut, loose or damaged fluid tube, or the cup tipped too far. See figure 5-35. Faulty spray patterns, their causes, and how to correct them are shown in figure 5-36.

Spray guns should be cleaned immediately after each use. To clean a suction gun, you should empty the container. Then, pour a small quantity of thinner or suitable solvent into the container. Draw the thinner or solvent through the gun by inserting the tube into the container of cleaning fluid. Move the trigger constantly to thoroughly flush the passageways and the tip of the fluid needle. Remove the air cap and soak it in solvent. If this action does not clean the small holes in the air cap, remove the paint material and use a toothpick or broomstraw to clean the holes. Do not use wire or other metal objects. They may cause permanent damage to the air cap.

To clean a pressure-feed gun, you should back off the fluid needle adjusting screw. Then, release the pressure from the pressure tank with the relief or safety valve. Hold a cloth over the air cap and operate the gun

	<p>DRIED MATERIAL IN SIDE-PORT "A" RESTRICTS PASSAGE OF AIR THROUGH IT. RESULT: FULL PRESSURE OF AIR FROM CLEAN SIDE-PORT FORCES FAN PATTERN IN DIRECTION OF CLOGGED SIDE.</p>		<p>DISSOLVE MATERIAL IN SIDE-PORT WITH THINNER. DO NOT POKE IN ANY OF THE OPENINGS WITH METAL INSTRUMENTS.</p>
	<p>DRIED MATERIAL AROUND THE OUTSIDE OF THE FLUID NOZZLE TIP AT POSITION "B" RESTRICTS THE PASSAGE OF ATOMIZING AIR AT ONE POINT THROUGH THE CENTER OPENING OF AIR NOZZLE AND RESULTS IN PATTERN SHOWN. THIS PATTERN CAN ALSO BE CAUSED BY LOOSE AIR NOZZLE.</p>		<p>IF DRIED MATERIAL IS CAUSING THE TROUBLE, REMOVE AIR NOZZLE AND WIPE OFF FLUID TIP USING RAG WET WITH THINNER. TIGHTEN AIR NOZZLE.</p>
	<p>A SPLIT SPRAY OR ONE THAT IS HEAVY ON EACH END OF A FAN PATTERN AND WEAK IN THE MIDDLE IS USUALLY CAUSED BY (1) TOO HIGH AN ATOMIZING AIR PRESSURE, OR (2) BY ATTEMPTING TO GET TOO WIDE A SPRAY WITH THIN MATERIAL.</p>		<p>REDUCING AIR PRESSURE WILL CORRECT CAUSE (1). TO CORRECT CAUSE (2), OPEN MATERIAL CONTROL "D" TO FULL POSITION BY TURNING TO LEFT. AT THE SAME TIME, TURN SPRAY WIDTH ADJUSTMENT "C" TO RIGHT. THIS WILL REDUCE WIDTH OF SPRAY, BUT WILL CORRECT SPLIT SPRAY PATTERN.</p>
<p>SPITTING</p>	<p>(1) DRIED OUT PACKING AROUND MATERIAL NEEDLE VALVE PERMITS AIR TO GET INTO FLUID PASSAGEWAY. THIS RESULTS IN SPITTING. (2) DIRT BETWEEN FLUID NOZZLE SEAT AND BODY OF A LOOSELY INSTALLED FLUID NOZZLE WILL MAKE GUN SPIT. (3) A LOOSE OR DEFECTIVE SWIVEL NUT ON SIPHON CUP OR MATERIAL HOSE CAN CAUSE SPITTING.</p>		<p>TO CORRECT CAUSE (1) BACK UP KNURLED NUT (E). PLACE TWO DROPS OF MACHINE OIL ON PACKING. REPLACE NUT AND TIGHTEN WITH FINGERS ONLY. IN AGGRAVATED CASES REPLACE PACKING. TO CORRECT CAUSE (2), REMOVE FLUID NOZZLE (F). CLEAN BACK OF NOZZLE AND NOZZLE SEAT IN GUN BODY USING RAG WET WITH THINNER. REPLACE NOZZLE AND DRAW UP TIGHTLY AGAINST BODY. TO CORRECT CAUSE (3) TIGHTEN OR REPLACE SWIVEL NUT BODY (G). INCREASE PRESSURE FROM YOUR AIR SUPPLY. CORRECT AIR PRESSURES ARE DISCUSSED ELSEWHERE IN THIS CHAPTER.</p>

Figure 5-36.—Faulty spray patterns and how to correct them.

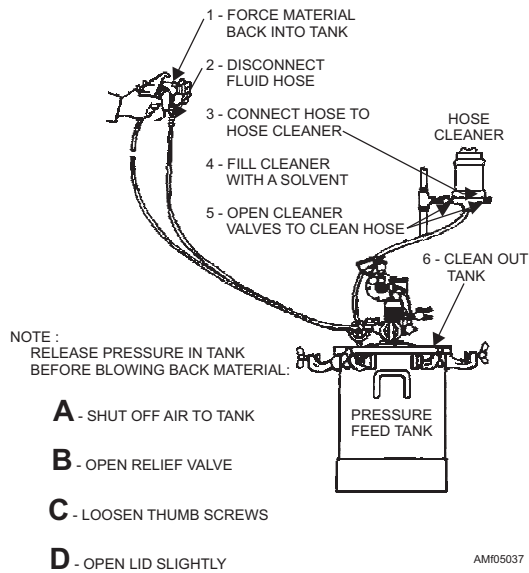

Figure 5-37.—Cleaning pressure-feed spray gun.

trigger. The cloth forces the spray material back into the pressure tank (fig. 5-37). Remove the fluid hose from the gun and the pressure tank. Attach a hose cleaner to the hose and run thinner or suitable solvent through it. Clean the air cap by using the same method as the suction gun air cap.

NOTE: Do not immerse an entire spray gun in cleaning materials, such as cleaning solvents and thinners. These materials dissolve the oil from leather packings and cause the gun to have an unsteady spray.

The gun, fluid needle packing, air valve stem, and trigger bearing screw require frequent lubrication. You should remove the fluid needle packing before using the gun and soften it with oil. The fluid needle spring should be coated with grease according to the manufacturer's instructions. See figure 5-38.

Air Compressors

To use a spray gun, you need a source of compressed air. Figure 5-39 shows two types of air

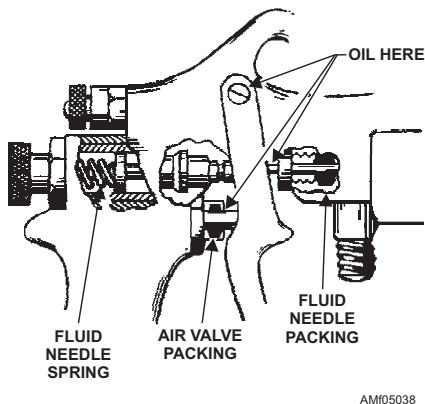
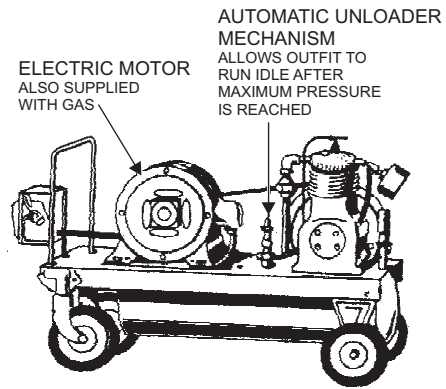

Figure 5-38.—Spray gun lubrication points.



CENTRIFUGAL PRESSURE RELEASE ALLOWS COMPRESSOR TO RUN FREE UNTIL NORMAL SPEED IS ATTAINED

PRESSURE SWITCH STOPS MOTOR WHEN MAXIMUM PRESSURE IS REACHED

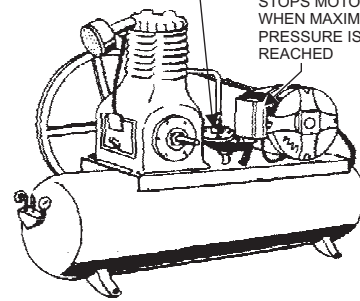

Figure 5-39.—Air compressors.

compressors—a portable unit and a stationary unit. Both types are commonly used. The portable unit consists of an electric or gasoline engine, compressor, storage tank, automatic unloader mechanism, wheels, and a handle. The stationary unit consists of an electric motor, compressor, storage tank, centrifugal pressure release, pressure switch, and mounting feet.

In addition to the standard spray equipment, special types have been developed for the occasional or small touchup job. There are many types available. Figure 5-40 shows one that consists of a self-contained power unit with an attached spray bottle (container). The



Figure 5-40.—Spray kit self-pressurized.

essential features include the power unit with a push-button spray cap on the top and on the bottom, and a screw lid that attaches to the container. A dip tube extends from the bottom of the power unit into the sealant. The power unit contains the propellant.

Air Regulators

The air regulator (transformer) is used to regulate the amount of pressure to the spray gun and to clean the air. The air delivered to the regulator always contains some oil from the compressor, some water caused by condensation, and many particles of dirt and dust.

Air regulators are equipped with a pressure valve and pressure regulating screw to regulate the pressure delivered to the spray gun. They also prevent pressure fluctuations. The air must pass through a sack or cleaner before it leaves the regulator. This cleaner is contained in the long cylindrical part of the regulator and should be drained daily. Air regulators are also equipped with two gauges. One shows the pressure on the main line while the other shows the pressure to the spray gun.

SPRAY GUN TECHNIQUE

Proper spray gun technique reflects knowledge of the equipment and experience. The spray gun should be held so the spray is perpendicular to the area to which the finish is being applied. You should ensure that the prescribed gun-to-work distance is maintained.

A distance of 6 to 10 inches from the gun to the work should be maintained when you are spraying epoxy-polyamide and polyurethane finishes. The gun should be held 8 to 10 inches from the work for lacquer and 6 to 8 inches for enamels. For a narrow pattern, the gun is held at the farther distances (10 inches for epoxy-polyamide and polyurethane, 10 inches for lacquer, and 8 inches for enamels).

A distance of less than 6 inches is undesirable because the paint will not atomize properly, and an *orange peel* will result. A distance of more than 10 inches is equally undesirable. Dried particles of paint will strike the surface and cause *dusting* of the finish. Examples of correct and incorrect spray gun techniques are shown in figure 5-41.

The distance the spray gun is held from the work is important; however, there are other factors to consider. The manner in which the gun is held and operated is also important. See figure 5-41. You should move your arm and body with the gun to keep the spray

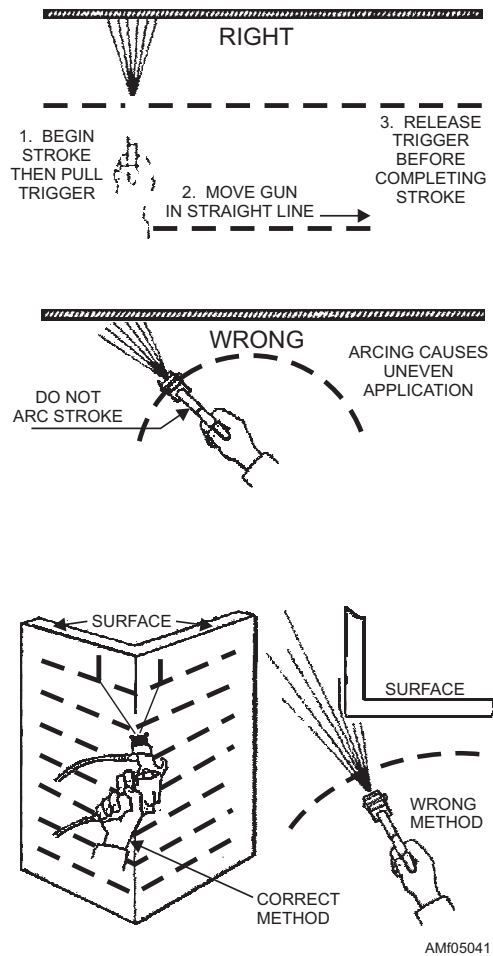

Figure 5-41.—Correct and incorrect methods of spraying.

perpendicular to the surface. Avoid pivoting and circular movements of the wrist or forearm. These may bring the gun closer to the surface.

It is important to *trigger* the gun in order to avoid an uneven coat at the beginning and end of a stroke. Triggering is the technique of starting the gun moving toward the area to be sprayed before the trigger is pulled and continuing the motion of the gun after the trigger has been released.

You should avoid too much overlapping on each pass of the gun because an uneven coat will result. The rate of the stroke should produce a full, wet, even coat. Once the job is started, it must be completed without stopping.

Spray Gun Adjustments

Figure 5-42 shows the principal parts of a typical spray gun. The spreader adjustment dial is used to adjust the width of the spray pattern. When you turn the dial to the right, a round pattern is obtained. When you turn to the left, a fan-shaped pattern results.

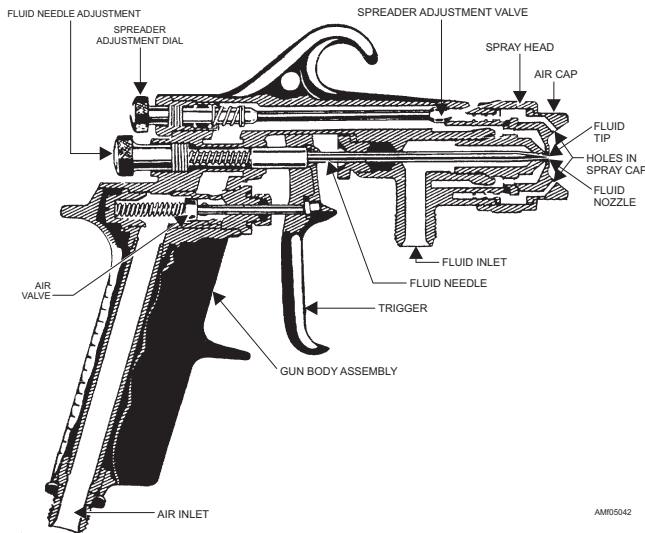

Figure 5-42.—Sectional view of typical spray gun.

As the width of the spray is increased, more material must be allowed to pass through the gun to get the same coverage on the increased area. To apply more material to the area, you should turn the fluid needle adjustment to the left. If too much material is applied to the surface, turn the fluid needle adjustment to the right. In normal operation, the wings on the air cap are adjusted to the horizontal position, as shown in figure 5-43. This provides a vertical fan-shaped pattern.

Spraying Pressures

Normally, you will be concerned about spray painting lacquer, enamel, and epoxy materials. The correct air and fluid pressures used with these materials vary. There are several pitfalls of incorrect pressures, some of which are as follows:

- Excessive air pressure may cause dusting and rippling of the finish.

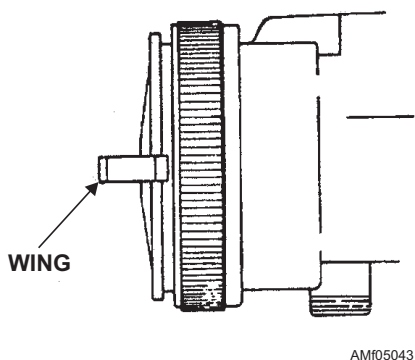

Figure 5-43.—Spray gun nozzle.

- Too little air pressure, coupled with excessive fluid pressure, causes orange peel.
- Excessive fluid pressure causes orange peel and sags.
- Too little fluid pressure causes dusting.

Q5-38. Regarding painting specifications for letters and numerals, how is the space measurement between letters and numerals determined?

Q5-39. What are tactical paint scheme patterns based on?

Q5-40. What type of paint spray gun is designed for small jobs?

Q5-41. What is the probable cause if your paint spray gun is leaking in the front?

Q5-42. What is the desirable distance from the surface that you should hold the spray gun in order to get the proper coverage and a smooth coat of paint?

Q5-43. What may cause dusting and rippling in a paint finish?

SEALANTS AND SEALING PRACTICES

LEARNING OBJECTIVE: Recognize the types of sealants and the procedures used to apply them.

Sealants are used to prevent the movement of liquid or gas from one point to another. They are used in an aircraft to maintain pressurization in cabin areas, to retain fuel in storage areas, to achieve exterior surface aerodynamic smoothness, and to weather-proof the airframe. Sealants are used in general repair work to maintain and restore seam integrity in critical areas where structural damage or paint remover has loosened existing sealants.

TYPES OF SEALANTS

The physical conditions surrounding the seal govern the type of sealant to be used. Some sealants are exposed to extremely high or low temperatures. Other sealants contact fuels and lubricants. Therefore, it is necessary to use a sealant that has been compounded for the particular condition. Sealants are supplied in different consistencies and cure rates. Basic sealants are classified in three general categories—pliable, drying, and curing.

Pliable Sealants

Pliable sealants are referred to as one-part sealants and are supplied “ready for use” as packaged. They are solids and change very little during or after application. Solvent is not used with pliable sealants. Therefore, drying is not necessary. Except for normal aging, they remain virtually the same as when they were packaged. They easily adhere to metal, glass, and plastic surfaces. Pliable sealants are used around access panels and doors and in areas where pressurization cavities must be maintained.

Drying Sealants

Drying sealants set and cure by evaporation of the solvent. Solvents are used in these sealants to provide the desired application consistency. Consistency or hardness may change when this type of sealant dries, depending on the amount of solvent it contains. Shrinkage during the drying process is an important consideration. The degree of shrinkage also depends upon the amount of solvent it contains.

Curing Sealants

Catalyst-cured sealants have an advantage over drying sealants because they are transformed from a fluid or semifluid state into a solid by chemical reaction rather than by evaporation of a solvent. A chemical catalyst or *accelerator* is added and mixed just prior to sealant applications. Heat may be employed to speed up the curing process. When you use a catalyst, you should accurately measure and thoroughly mix the two components to ensure a complete and even cure.

APPLICATION OF SEALANTS

The application of sealants varies according to time, tools required, and the application method. However, the following restrictions apply to all sealant applications:

- Sealant should be used within the application time limits specified by the sealant manufacturer.
- Sealant should not be applied to metal that is colder than 70°F. Better adhesion is obtained and the applied sealant will have less tendency to flow while curing if the metal is warmed to a temperature between 90°F and 100°F before the sealant is applied.
- Sealant should be discarded immediately when it becomes too stiff to apply or work. Stiff or partially

cured sealant will not wet the surface to which it is to be applied as well as fresh material and, consequently, will not have satisfactory adhesion.

- Sealant should not be used for faying surface applications unless it has just been removed from refrigerated storage or freshly mixed.

While the use of sealants on aircraft surfaces has greatly increased over the past few years, application methods have been mostly through the use of brushes, dipping, injection guns, and spatulas. The spraying of sealants is a recent development. MIL-S-81733 sealant, type III, is extensively used for spray application. If type III sealant cannot be procured, MIL-S-8802 sealant, class A, may be used by thinning it to a sprayable consistency by the addition of an appropriate solvent.

Figure 5-44 shows sealant applied to an aircraft to protect some of the most corrosion-prone areas. The sealant was applied using spray, spatula, and brush methods.

When you are pressure sealing an aircraft, the sealing materials should be applied to produce a continuous bead, film, or fillet over the sealed area. Air bubbles, voids, metal chips, or oily contamination will prevent an effective seal. Therefore, the success of the sealing operation depends upon the cleanliness of the area and the careful application of the sealant materials. There are various methods of pressure sealing the joints and seams in aircraft. The applicable structural repair manual will specify the method to be used in each application.

The sealing of a faying surface is accomplished by brush coating the contacting surfaces with the specified sealant. The sealant should be applied immediately before fastening the parts together.

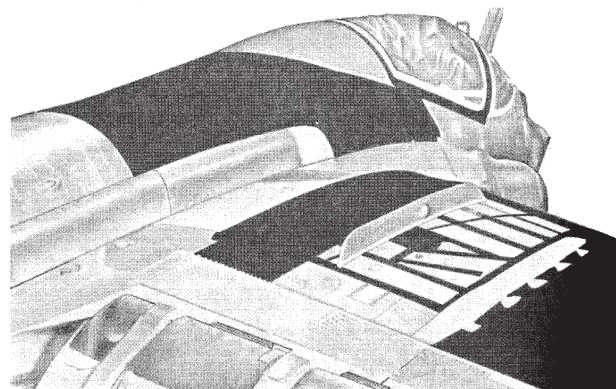

AM105044

Figure 5-44.—Sealant applied to aircraft exterior surfaces.

Careful planning is necessary to close faying surface seals on large assemblies within the application time limit of the sealant. Once the sealant has been applied, the parts must be joined, the required number of bolts must be torqued, and all the rivets driven within this time limit.

When insulating tape has been installed between the faying surfaces to prevent dissimilar metals contacts, pressure sealing should be accomplished by fillet sealing. Fillet sealing is the spreading of sealant along the seam with a sealant injection gun. The sealant should be spread in approximately 3-foot increments. Before you proceed to the next increment, the applied portion of the fillet should be worked with a sealant spatula or tool. See figure 5-45. This working of the sealant fills the voids in the seam and eliminates air bubbles. The leak-free service life of the sealant is determined by the thoroughness and care you use in working out the air bubbles.

After the sealant has cured to a tack-free condition, the fillet should be inspected for any remaining air bubbles. Such air bubbles should be opened and filled with sealant.

When a heavy fillet is required, it should be applied in layers. The top layer should fair with the metal.

Injection sealing is the pressure filling of openings or voids with a sealant injection gun. Joggles should be filled by forcing sealant into the opening until it emerges from the opposite side. Voids and cavities are filled by starting with the nozzle of the sealant injection gun at the bottom of the space and filling as the nozzle is withdrawn.

NOTE: A joggle is a joint between two pieces of material formed by a notch and a fitted projection.

Rivets, rivnuts, screws, and small bolts should have a brush coat of sealant over the protruding portion on the pressure side. Washers should have a brush coat of

sealant on both sides. Split grommets should have sealant brushed into the split prior to installation. After installation, fillets should be applied to both the base of the grommet and the protruding tube in the pressure side.

Sealing Compound MIL-S-8802

This temperature-resistant, two-component, synthetic rubber compound is used for sealing and repairing fuel tanks and fuel cell cavities. This compound is designed for an operating environment that may vary between -65°F and $+250^{\circ}\text{F}$. It is produced in the following classifications:

Class A. Sealing material suitable for brush application,

Class B. Sealing material suitable for application by extrusion gun and spatula

Class C. Sealing material suitable for faying surface sealing

Dash numbers after the classification code indicate the allowed application time in hours before the curing cycle will have progressed to the point where it is no longer feasible to apply that particular batch of sealant. Class A dash numbers are $-1/2$ and -2 . Class B dash numbers are $-1/2$, -2 , and -4 . Class C dash numbers are -20 and -80 (8 hours of application time with the remaining time allowed for working the material).

Example: Class A-2 designates a brushable material having an application time of 2 hours. Class B- $1/2$ designates an extrusion gun material having an application time of $1/2$ hour. Class C-20 designates a faying surface sealant with an application time of 8 hours and a working life of 20 hours.

Sealing Compound MIL-S-81733

This accelerated, room temperature, curing synthetic rubber compound is used in sealing metal components on weapons and aircraft systems for protection against corrosion. This sealant contains magnesium chromate as a corrosion inhibitor. The classification of this sealant compound is of the following types:

Type I. For brush or dip application

Type II. For extrusion application, gun or spatula

Type III. For spray gun application

Dash numbers after the type code are used to designate the maximum application time in hours. Type

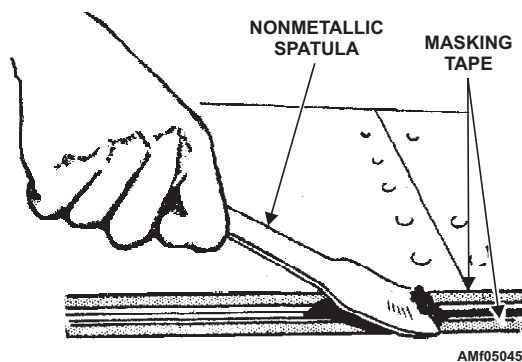

Figure 5-45.—Applying sealant.

I dash numbers are -1/2 and -2. Type II dash numbers are - 1/2, -2, and -4. The Type III dash number is -1.

Q5-44. Basic sealants are classified in how many general categories?

Q5-45. What is used to apply Class B sealing materials?

SAFETY PRECAUTIONS

Many of the sealants previously discussed may be flammable or may produce toxic vapors. When you are

using any material designated as flammable, all sources of ignition must be at least 50 feet away from the location of the work. Toxic vapors are produced by the evaporation of solvents or the chemical reaction taking place in the curing sealants. When you are using sealants in confined spaces, such as fuel cells, fuselage, or wing sections, adequate local exhaust ventilation must be used to reduce the vapors below the maximum allowable concentration. The vapors must be kept at that level until repairs have been completed. Do not eat or smoke when you are working with sealants.

CHAPTER 6

NONDESTRUCTIVE INSPECTIONS, WELDING, AND HEAT TREATMENT

INTRODUCTION

The basic principles and procedures of nondestructive inspections, welding, and the heat treatment of metals are covered in this course. These three areas require special training, and in the case of nondestructive inspections (NDI) and welding, they require special certification prior to performing these two functions. While not all AMs are required to become NDI operators, aeronautical equipment welders, or have the need to perform heat treatment of metal, there is the need to be familiar with these procedures and how they apply to the AM rate. The information in these areas is being presented in a broad nature. For a more detailed discussion of these procedures, refer to the applicable technical manuals.

NONDESTRUCTIVE INSPECTION PROGRAM

LEARNING OBJECTIVES: Evaluate the background and personnel training required for the NDI program. Identify various NDI personnel qualifications.

In the hands of a trained and experienced technician, nondestructive inspection (NDI) methods allow detection of flaws or defects in materials with a high degree of accuracy and reliability. It is important that you become fully knowledgeable of the capabilities of each NDI method, but it is equally important that you recognize the limitations of these methods. The non-destructive inspection methods covered in this chapter serve as tools of prevention, which allow defects to be detected before they develop into serious failures.

During the inspection of aircraft, it is essential that faults are found and corrected before they reach catastrophic proportions. In applicable areas, NDI can provide 100-percent sampling with no affect upon the use of the part or system being inspected. The effective use of NDI will result in increased operational safety, and in many instances, dramatically reduce maintenance man-hour expenditures.

NDI is the practice of evaluating a part or sample of material without impairing its future usefulness. The methods used in naval aviation include, but are not

limited to, visual or optical, liquid penetrant, magnetic particle, eddy current, ultrasonic, and radiographic. The success in their use depends heavily upon intelligent application and discriminating interpretation of results.

NDI is performed only by qualified and currently certified NDI personnel, and in accordance with NA 01-1A-16, *Nondestructive Inspection Methods* manual. This is a general manual covering the theory and general applications of the various methods of NDI.

The Aircraft Nondestructive Inspection School, located at NATTC Pensacola, Florida, provides NDI technician training for both military and civil service personnel. Career designated (grade E-4 and above) Navy aviation structural mechanics (AMs), Marine Corps structural mechanics, and equivalent civil service personnel are eligible for the course. In addition, NDI operator training in liquid penetrant, magnetic particle, and eddy current methods; refresher training; and recertification of NDI technicians are provided by the Naval Aviation Depot (NADEP) and aircraft controlling custodian or type commander (ACC/TYCOM) designated NDI specialists. Requests for NADEP training and authorization for recertification of NDI technicians who have been inactive in NDI for more than 1 year must be made, via the chain of command, to the cognizant ACC/TYCOM. If the request is approved, the ACC/TYCOM will advise which NADEP is to be used.

NDI PERSONNEL

Before candidates are selected for NDI technician or operator training, and annually thereafter, they are required to have an eye examination. Military and civilian NDI personnel are identified as NDI specialists, technicians, or as operators.

NDI Specialists

NDI specialists are authorized by the ACC to provide training and certification/recertification of NDI technicians/operators. They also provide technical NDI services.

NDI Technicians

NDI technicians are personnel who have successfully completed the NDI course (C-603-3191) at Aircraft Nondestructive Inspection School at NATTC Pensacola, Florida. NDI technicians are assigned NEC 7225/MOS 6044, and they are qualified and certified to perform liquid penetrant, magnetic particle, eddy current, ultrasonic, and radiographic methods of NDI. These personnel are normally assigned to intermediate maintenance activities (IMAs). NDI technicians with 3 or more years of experience and who are currently certified and engaged in NDI on a regular basis may be authorized by ACCs to train and certify NDI operators for specific NDI applications. The ACC may also waive the 3-year experience requirement provided requests for this authorization are addressed to the ACC/TYCOM via the appropriate wing.

This request must include the technician's current qualification, experience history, and the specific technical directive/technical publication-directed NDI applications for which operator certification is to be provided. If approved, a copy of the ACC authorization will be attached to the technician's NDI certification record and maintained with his/her individual NDI record. Such authorizations remain in effect only as long as the currency of certification and NDI experience is maintained. Currently active NDI technicians require recertification every 3 years.

Early recertification is authorized and encouraged to prevent expiration of certification during tours of deployed duty. Current certification of NDI technicians who are regularly engaged in all methods of NDI may be extended by ACCs for up to 1 year if circumstances warrant. NEC 7225 personnel who have been inactive in NDI for 1 year or more require recertification before resuming active NDI technician status. Recertification is provided by designated NADEPs or by ACC designated and qualified NAESU Navy federal civilian or military technical specialists.

NDI Operators

NDI operators are military personnel E-4 and above, or civilian equivalent, who have successfully completed training and are certified to perform specific NDI tasks using one or more of the following methods: liquid penetrant, eddy current, or magnetic particle.

NDI operators may be assigned and used in IMAs to perform specific publication-directed NDI tasks only when the NDI workload exceeds the capacity of assigned NDI technicians. Each case of NDI operator use at I-level maintenance must be authorized by the cognizant ACC. Requests for such authorizations are made to the ACC via the appropriate wing.

Basic NDI operator training is provided by NADEPs and NDI specialists. When training is not available, ACCs may authorize the training of NDI operators by NDI technicians in specific liquid penetrant kit applications. NDI operator certification/recertification is provided by NDI specialists and NDI technicians. Recertification of NDI operators is required annually. NDI operators at I-level activities must be closely monitored by qualified NDI technicians and by cognizant QARs/CDQARs. NDI operators are not authorized to operate radiographic or ultrasonic equipment. They may, however, be used to assist NDI technicians operating that equipment.

NDI technicians and operators must use the NDI method or methods for which they are certified at least two times each month, as evidenced by entries on their work record (OPNAV 4790/140). This can be done either through normal workload or practice applications. In those cases where the prescribed proficiency is not maintained for 1 or more months, technicians or operators can regain proficiency by making practice applications under the supervision of a certified NDI technician, who will provide recertification upon determination of proficiency. Failure to maintain proficiency for 6 months for NDI operators and 12 months for NDI technicians will require updated training for recertification. NDI technicians who fail to maintain proficiency for 3 years or more will require complete retraining. In all cases exceeding 6 months for operators and 12 months for technicians, authorization for updated training or complete retraining is requested from the cognizant ACC.

Activities that are authorized to certify/recertify NDI technicians and operators must administer an appropriate written test on the NDI methods involved. The NA 01-1A-16 manual is the source for test questions. Personnel being certified or recertified will also be required to demonstrate the ability to perform NDI inspections as appropriate. The objective is to provide sufficient testing of the candidate to ensure the person is competent to conduct NDIs.

The effectiveness of the NDI program can be enhanced through development of new NDI techniques/applications by efficient and inventive NDI personnel. Useful new techniques, so developed, will be submitted to the appropriate CFA for approval and distribution to other fleet activities. An information copy is submitted to the ACC NDI specialist.

NDI CERTIFICATION RECORD

This form (fig. 6-1) provides a record of certification. The original copy goes to the individual, with one copy each to quality assurance/analysis (QA/A) and the division officer. All certified NDI personnel must initiate and maintain individual records of NDI performed.

OPNAVINST 4790.2H

NDI CERTIFICATION RECORD	
1. NAME	2. RATE/RANK
3. CERTIFYING ACTIVITY	
4. EFFECTIVE DATE	5. RECERTIFICATION DUE DATE
6. THIS INDIVIDUAL IS CERTIFIED TO CONDUCT NDI BY USE OF THE FOLLOWING METHOD(S):	
<input type="checkbox"/> RADIOGRAPHY	<input type="checkbox"/> EDDY CURRENT
<input type="checkbox"/> LIQUID PENETRANT	<input type="checkbox"/> ULTRASONIC
<input type="checkbox"/> MAGNETIC PARTICLE	<input type="checkbox"/> OTHER (<i>Specify in remarks</i>)
7. REMARKS:	
8. SIGNATURE (<i>Certifying Official</i>)	9. DATE
Original To: Individual's Qualification/Certification Record	

Figure 6-1.—NDI Certification Record (OPNAV 4790/139).

NDI TECHNICIAN/OPERATOR WORK RECORD

This form (fig. 6-2) is used to record and verify NDI performed. Entries will be verified by the individual's work center supervisor, or, if the work

center supervisor performs the NDI, by QA/A. Personnel doing repetitive NDI, such as eddy current on aircraft wheels, may record weekly entries, as indicated on the sample entry in figure 6-2. Upon transfer, NDI work records are carried by the individual to his/her next command.

OPNAVINST 4790.2C

NDI TECHNICIAN/OPERATOR WORK RECORD				
1. NAME			2. RATE/RANK	
3. ORGANIZATION				
4. DATE IN			5. DATE OUT	
6. DATE	7. NDI METHOD	8. HRS	9. REMARKS	10. VERIFIED

Figure 6-2.—NDI Technician/Operator Work Record (OPNAV 4790/140).

NDI PROGRAM RESPONSIBILITIES

NDI is of vital concern at all levels of maintenance, and all operational and support commanders should direct their efforts toward its proper use. NDI is used in the maintenance of Navy aircraft and aircraft systems wherever contributions to safety, reliability, QA, performance, or economy can be realized.

Naval Air Systems Command

The Naval Air Systems Command (NAVAIR) has cognizance over the NDI program. They are responsible for managing a program of research, development, training, and application of NDI techniques and equipment. NAVAIRINST 13070.1A assigns the responsibility for nondestructive testing and inspection within NAVAIR. NAVAIR is responsible for the following:

1. Coordinate and issue information on NDI within naval aviation, other services, and industry, as appropriate
2. Ensure appropriate application of NDI at all levels of maintenance
3. Procure NDI equipment to support an effective program
4. Procure NDI technical publications, and ensure the updating of such publications as newer techniques and applications are developed
5. Establish the necessary standards and specifications for NDI
6. Monitor, evaluate, and standardize the NADEPs NDI program
7. Provide NDI training for the NADEPs, as requested
8. Assign an NDI program coordinator to be responsible for managing implementation of the application and training elements

Aircraft Controlling Custodians

Aircraft controlling custodians (ACCs) are responsible for the following:

1. Monitoring the NDI program in activities under their cognizance
2. Advising on availability and location of NDI training

3. Maintaining liaison with NAVAIR, NADOC, Naval Aviation Maintenance Office (NAMO), NADEPs, and fleet activities on NDI matters

4. Ensuring that NDI laboratories, equipment, and personnel are audited as required
5. Designating NDI specialists, as required
6. Designating an NDI program manager

Intermediate Maintenance Activities

Intermediate maintenance activities (IMAs) are responsible for the following:

1. Ensuring compliance with qualification requirements and safety precautions.
2. Ensuring industrial radiation safety requirements are strictly enforced in accordance with the *Radiological Affairs Support Program (RASP)* manual, NAVSEA S0420-AA-RAD-010.
3. Using available NDI equipment fully, and developing new procedures and applications, as far as practical, to provide labor, material, and cost savings.
4. Maintaining an adequate number of certified and proficient NDI technicians at all times to provide NDI services to supported organizations and transient aircraft.
5. Ensuring the material condition of NDI equipment and the laboratory is continuously "ready for use" (RFU). This includes availability of consumable items.
6. Establishing and maintaining a continuing training program within the NDI work center to allow NDI technicians to remain up to date with newly developed NDI techniques and applications.
7. Establishing and maintaining liaison with the cognizant ACC NDI specialist, and requesting assistance via the chain of command on all NDI problems.
8. Providing and maintaining industrial X-ray film processing facilities, both ashore and afloat.
9. Providing scheduled and unscheduled NDI support to O-level activities, as required.
10. Maintaining liaison with ship/station radiation officer.

Quality Assurance/Analysis

Quality assurance/analysis (QA/A) is responsible for the following:

1. Monitoring compliance with NDI personnel qualifications, certification/recertification requirements, safety precautions, and instructions.
2. Monitoring the organization's NDI training program to ensure it is current and comprehensive. Special emphasis should be placed on those areas of NDI that are accomplished by personnel other than those assigned Navy enlisted classification (NEC) 7225/military occupational specialty (MOS) 6044.

Organizational Maintenance Activities

O-levels responsibilities are as follows:

1. Request NDI I-level support as required.
2. Obtain IMA NDI services in all situations where NDI results are suspicious.
3. Have an NDI technician verify defects discovered by an NDI operator, whenever possible.
4. Inform the IMA, in advance, of scheduled NDI requirements. Include these requirements in the monthly maintenance plan.
5. O-level NDI technicians may be assigned to the supporting IMA, as necessary, to maintain their proficiency and to augment IMAs NDI capabilities.

NDI INSPECTION METHODS

The various NDI methods serve as tools of prevention that allow defects to be detected before they develop into serious or hazardous failures. With the NDI methods, a trained and experienced technician can detect flaws or defects with a high degree of accuracy and reliability. It is important that you become fully knowledgeable of the capabilities of each method. It is equally important that you recognize the limitations of the methods. Some of the defects found by NDI include corrosion, leaks, pitting, heat/stress cracks, and discontinuity of metals. The following paragraphs will give a brief synopsis of the various NDI inspections. For further information on NDI procedures, you should consult the *Nondestructive Inspections Manual*, NA-01-1A-16, or the appropriate inspection manual pertaining to the type of aircraft or part that is to be inspected by an NDI method.

Magnetic Particle Inspection

Magnetic particle inspection is a rapid, non-destructive means of detecting discontinuities in parts made of magnetic materials. If the part is made from an

alloy that contains a high percentage of iron and can be magnetized, it is in a class of metals called "ferromagnetic," and it can be inspected by this method. If the part is made of material that is nonmagnetic, it cannot be inspected by this method. The magnetic particle inspection method will detect surface discontinuities, including those that are too fine to be seen with the naked eye, those that lie slightly below the surface, and, when special equipment is used, the more deeply seated discontinuities.

The inspection process consists of inducing a magnetic field into a part and applying magnetic particles, in liquid suspension or dry powder, to the surface being inspected. When the magnetic field is interrupted by a discontinuity, some of the field is forced out into the air above the discontinuity, forming a leakage field. The leakage field will be stronger and more concentrated the closer the discontinuity is to the surface. The presence of a discontinuity is detected by the ferromagnetic particles applied over the surface. Some of these particles will be gathered and held by the leakage field. This magnetically held collection of particles forms an outline of the discontinuity and indicates its location, size, and shape.

Electric current is used to create or induce magnetic fields in magnetic materials. The magnetic lines of force are always aligned at right angles (90°) to the direction of the current flow. The direction of the magnetic field can be altered, and it is controlled by the direction of the magnetizing current. The arrangement of the current paths is used to induce the magnetic lines of force so that they intercept and are as near as possible at right angles to the discontinuity.

The magnetic field must be in a favorable direction to produce indications. When the flux lines are oriented in a direction parallel to a discontinuity, the indication will be weak or lacking. The best results are obtained when the flux lines are in a direction at right angles to the discontinuity. If a discontinuity is to produce a leakage field and a readable magnetic particle indication, the discontinuity must intercept the flux lines of force at some angle. When an electrical magnetizing current is used, the best indications are produced when the path of the magnetizing current is flowing parallel to the discontinuity, because the magnetic flux lines are always at an angle of 90° to the flow of the magnetizing current. The two types of magnetizing methods used are circular and longitudinal.

CIRCULAR MAGNETIZATION.—Circular magnetization is used for the detection of radial discontinuities around edges of holes or openings in

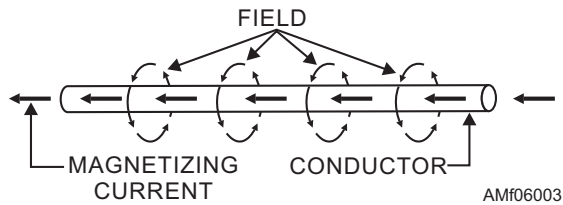

Figure 6-3.—Magnetic field surrounding an electrical conductor.

parts. It is also used for the detection of longitudinal discontinuities, which lie in the same direction as the current flow either in a part or in a part that a central conductor passes through.

Circular magnetization derives its name from the fact that a circular magnetic field always surrounds a conductor, such as a wire or a bar carrying an electric current (fig. 6-3). The direction of the magnetic lines of force (magnetic field) is always at right angles to the direction of the magnetizing current. An easy way to remember the direction of magnetic lines of force around a conductor is to imagine that you are grasping the conductor with your hand so that the extended thumb points parallel to the electric current flow. The fingers then point in the direction of the magnetic lines of force. Conversely, if the fingers point in the direction of current flow, the extended thumb points in the direction of the magnetic lines of force.

Since a magnetic part is in effect a large conductor, electric current passing through this part creates a magnetic field in the same manner as with a small conductor (fig. 6-4). The magnetic lines of force are at right angles to the direction of the current as before. This type of magnetization is called "circular magnetization" because the lines of force, which represent the direction of the magnetic field, are circular within the part.

To create or induce a circular field in a part with stationary magnetic particle inspection equipment, the part is clamped between the contact plates and current is passed through the part, as indicated in figure 6-5. This sets up a circular magnetic field in the part that creates poles on either side of any crack or discontinuity that runs parallel to the length of the part. The poles will attract magnetic particles, forming an indication of the discontinuity.

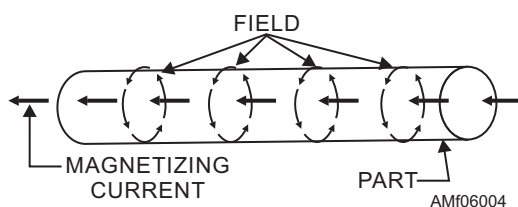

Figure 6-4.—Magnetic field in part used as a conductor.

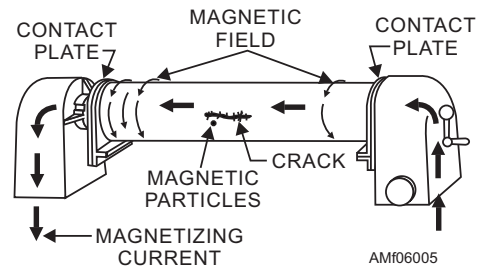

Figure 6-5.—Creating a circular magnetic field in a part.

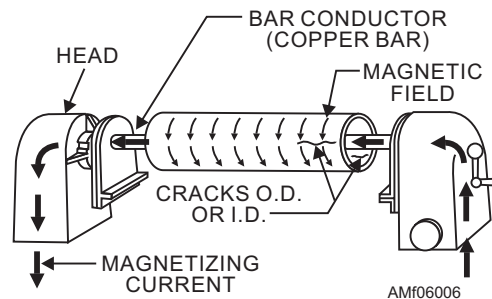

Figure 6-6.—Using a central conductor to circularly magnetize a cylinder.

On parts that are hollow or tubelike, the inside surfaces are as important to inspect as the outside. When such parts are circularly magnetized by passing the magnetizing current through the part, the magnetic field on the inside surface is negligible. Since there is a magnetic field surrounding the conductor of an electric current, it is possible to induce a satisfactory magnetic field by placing the part on a copper bar or other conductor. This situation is illustrated in figures 6-6 and 6-7. Passing current through the bar induces a magnetic field on both the inside and outside surfaces.

LONGITUDINAL MAGNETIZATION.—Longitudinal magnetization is used for the detection of circumferential discontinuities, which lie in a direction transverse to or at approximately right angles to a parts axis. Electric current is used to create a longitudinal magnetic field in a piece of magnetic material. When a part of magnetic material is placed inside a coil, as

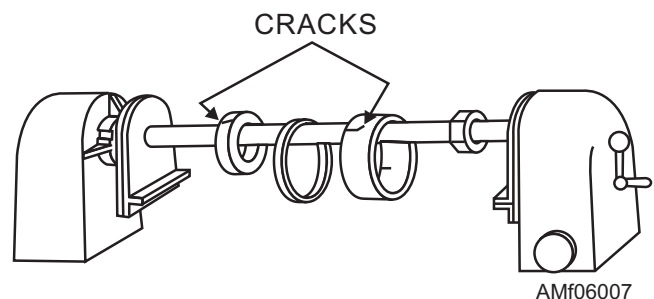

Figure 6-7.—Using a central conductor to circularly magnetize ringlike parts.

shown in figure 6-8, the magnetic lines of force created by the magnetizing current concentrate themselves in the part and induce a longitudinal magnetic field. Inspection of a cylindrical part with longitudinal magnetism is shown in figure 6-9. If there is a transverse discontinuity in the part, such as that in the illustration, small magnetic poles are formed on either side of the crack. These poles will attract magnetic particles, forming an indication of the discontinuity. Compare figure 6-9 with figure 6-5, and note that in both cases a magnetic field has been induced in the part that is at right angles to the defect. This is the most desirable condition for a reliable inspection.

ALTERNATING CURRENT.—The use of alternating current (ac) in magnetic particle inspection is recommended only for the detection of surface discontinuities, which comprise the majority of service-induced defects. Fatigue and stress corrosion cracks are examples of cracks usually open to the surface. Alternating current, which must be single phase when used directly for magnetizing purposes, is taken from commercial power lines or portable power sources, and is usually 50 or 60 hertz.

DIRECT CURRENT.—Direct current (dc) magnetizes the entire cross section more or less uniformly in the case of longitudinal magnetization. Magnetic fields produced by direct current penetrate deeper into a part than fields produced by alternating current, which makes it possible to detect subsurface discontinuities. Generally, direct current is used with wet magnetic particle methods. In the presence of dc fields, dry powder particles behave as though they were immobile, tending to remain wherever they happen to land on the surface of a part. This is in contrast to what happens with dry powder particles in the presence of ac fields. In these fields, the particles have mobility on a surface due to the pulsating character of the fields. Particle mobility aids considerably the formation of particle accumulations (indications) at discontinuities.

PARTICLES AND METHODS OF APPLICATION.—The particles used in magnetic particle testing

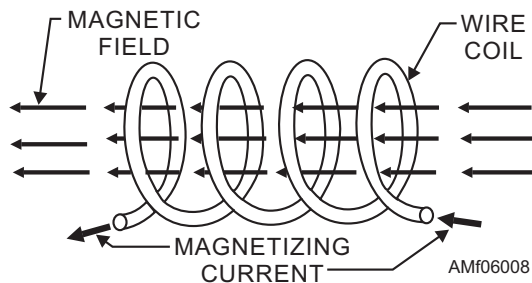

Figure 6-8.—Magnetic field in a part placed in a coil.

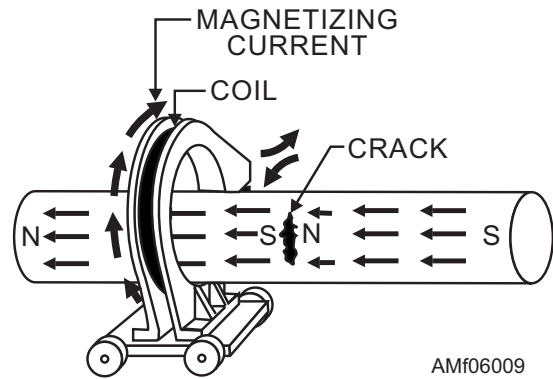

Figure 6-9.—Coil creates a longitudinal field to show crack in a part.

are made of magnetic materials, usually combinations of iron and iron oxides, that have a high permeability and low retentivity. Particles that have high permeability are easily magnetized by and attracted to the low-level leakage fields at discontinuities. Low retentivity is required to prevent the particles from being permanently magnetized. Strongly retentive particles tend to cling together and to any magnetic surface, resulting in reduced particle mobility and increased background accumulation.

Particles are very small and are various sizes. Each magnetic particle formulation always contains a range of sizes and shapes to produce optimum results for the intended use. The smallest particles are more easily attracted to and held by the low-level leakage fields at very fine discontinuities; larger particles can more easily bridge across coarse discontinuities, where the leakage fields are usually stronger. Elongated particles are included, particularly in the case of dry powders, because these rod-shaped particles easily align themselves with leakage fields not sharply defined, such as those that occur over subsurface discontinuities. Global-shaped particles are included to aid in the mobility and uniform dispersion of particles on a surface.

Magnetic particles may be applied as a dry powder, or wet, by using either water or a high flash point petroleum distillate as a liquid vehicle carrier. Dry powder is available in various colors, so the user can select the color that contrasts best with the color of the surface upon which it is used. Colors for use with ordinary visible light are red, grey, black, or yellow. Red- and black-colored particles are available for use in wet baths with ordinary light, and yellow-green fluorescent particles for use with a black light. Fluorescent particles are widely used in wet baths, since the bright fluorescent indications produced at discontinuities are readily seen against the dark backgrounds that exist in black light inspection areas.

Radiographic Inspection

Radiographic is a nondestructive inspection method that uses a source of X-rays to detect discontinuities in materials and assembly components. Radiation is projected through the item to be tested, and the results are captured on film. Radiography may be used on metallic, nonmetallic, and combination metallic/nonmetallic materials and assemblies without access to the interior. However, defects must be correctly aligned and oriented with respect to penetrating rays to be reliably detected. Radiography is one of the most expensive and least sensitive methods for crack detection. It should only be used to detect flaws that are not accessible or favorably oriented for use by other test methods.

The extent of recorded information is dependent upon the following three prime factors:

1. The composition of the material.
2. The product of the density and the thickness of the material.
3. The energy of the X-rays, which is incident upon the material. Material discontinuities cause an apparent change in these characteristics, and thus make themselves detectable.

Figure 6-10 is a diagram of radiographic exposure showing the elements of the system. Radiation passes through the object and produces an invisible or latent image in the film. When processed, the film becomes a radiograph or shadow picture of the object. Since more radiation passes through the object where the section is thin or where there is a space or void, the corresponding area on the film is darker. The radiograph is read or interpreted by comparing it with the known nature of the object.

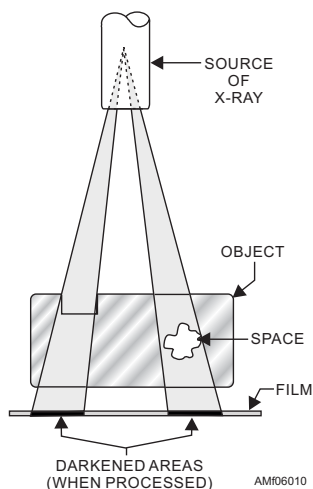

Figure 6-10.—Diagram of radiographic exposure.

RADIOGRAPHIC INTERPRETATION.—The usefulness of the information obtained from the radiographic process depends upon the intelligent interpretation of the derived image. To successfully interpret the radiograph, the radiographic interpreter must have a working knowledge of the component or material and be able to relate the images to the conditions likely to occur. Specifications are used to spell out the discontinuities that maybe considered detrimental to the function of the part and the acceptable magnitudes of the discontinuities. It is the duty of the film interpreter to recognize the various discontinuities, their magnitudes, and be capable of relating them to the particular specification required. The responsibility and capability of the radiographic interpreter cannot be overemphasized. Often, many human lives and investments of millions of dollars are depending on the judgment of the radiographic interpreter.

RADIATION HAZARD.—Radiation from X-ray units is destructive to living tissue. It is universally recognized that in the use of such equipment, adequate protection must be provided to personnel. Personnel must keep outside the primary X-ray beam at all times.

Radiation produces changes in all matter that it passes through. This is also true of living tissue. When the radiation strikes the molecules of the body, the effect may be no more than to dislodge a few electrons; but an excess of these changes could cause irreparable harm. When a complex organism is exposed to radiation, the degree of damage, if any, depends on which of its body cells have been changed. The more vital parts are in the center of the body; therefore, the more penetrating radiation is likely to be the more harmful in these areas. The skin usually absorbs most of the radiation; therefore, it reacts earliest to radiation.

If the whole body is exposed to a very large dose of radiation, it could result in death. In general, the type and severity of the pathological effects of radiation depend on the amount of radiation received at one time and the percentage of the total body exposed. The smaller doses of radiation may cause blood and intestinal disorders in a short period of time. The more delayed effects are leukemia and cancer. Skin damage and loss of hair are also possible results of exposure to radiation.

Ultrasonic Inspection

The term *ultrasonic* means vibrations or sound waves whose frequencies are greater than those that

affect the human ear (greater than about 20,000 cycles per second).

Ultrasonic inspection is a method of inspection that uses these sound waves. The ultrasonic vibrations are generated by applying high-frequency electrical pulses to a transducer element contained within a search unit. The transducer element transforms the electrical energy into ultrasonic energy. The transducer element can also receive ultrasonic energy and transform it into electrical energy. Ultrasonic energy is transmitted between the search unit and the test part through a coupling medium, such as oil, as shown in figure 6-11, for the purpose of excluding the air interface between the transducer and the test part. The ultrasonic vibrations are transmitted into and through the part. When the beam strikes the far surface of the part or strikes the boundary of a defect, the beam reflects back towards the transducer, travels through the couplant, and enters the transducer, where it is converted back into electrical energy. Then, the information is displayed on a cathode-ray tube (CRT) screen.

Ultrasonic inspections can be separated into two basic categories—contact inspection and immersion inspection. In the contact method, the search unit is placed directly on the test part surface by using a thin film of couplant, such as oil, to transmit sound into the test part. In the immersion method, the test part is immersed in a fluid, usually water, and the sound is transmitted through the water to the test part (fig. 6-12). The immersion-type method is used to inspect materials while they are immersed in a suitable liquid, such as water or oil. This method proves more satisfactory than contact testing for irregular-shaped surfaces. Immersion inspection also permits use of a wider range of testing frequencies. The three general methods of contact inspections are straight-beam, angle-beam, and the surface-wave method.

STRAIGHT BEAM.—The straight-beam method is used to detect discontinuities parallel to the test surface, and is generally used on material 1/2 inch thick or greater. Most straight-beam methods are applied by using the pulse-echo technique (transmitting and

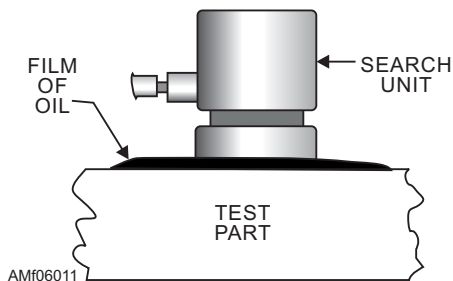

Figure 6-11.—Coupling of search unit to test part for transmission of ultrasonic energy.

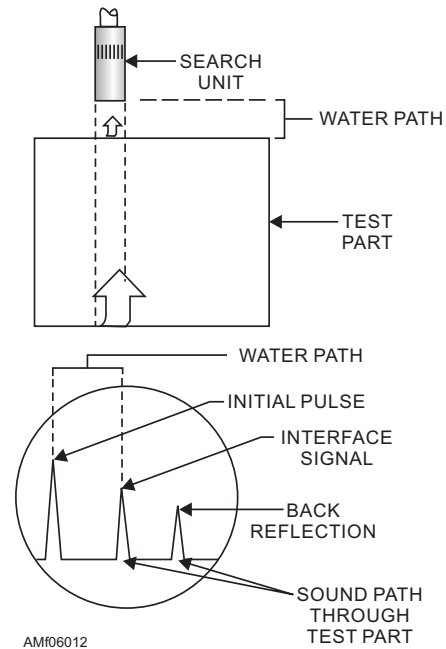

Figure 6-12.—Immersion method.

receiving search unit or units placed on the same surface). Certain applications use the through-transmission method (transmitting search unit placed on one surface, and receiving search unit placed on the opposite surface). In the through-transmission method, discontinuities block the passage of sound. This results in a reduction of the received signal (fig. 6-13). With this method, echoes from the discontinuities are not shown on the CRT. Therefore, depth information on the discontinuities is not determined. Typical discontinuity examples are laminations, corrosion, and cracks.

ANGLE BEAM.—Angle-beam methods are used extensively for field NDI, and can provide for inspection of areas with complex geometry or limited access. This is because angle beams can travel through a material by bouncing from surface to surface. Useful inspection information can be obtained at great distances from the search unit. Angle-beam inspections are particularly applicable to inspections around fastener holes, inspection of cylindrical components,

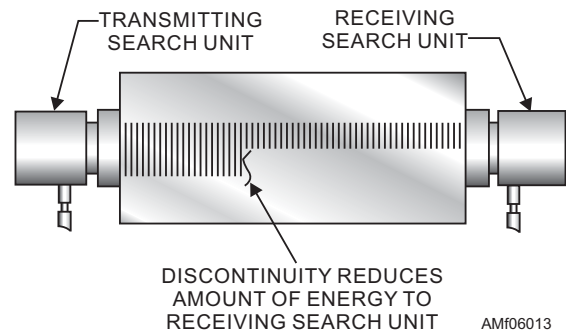

Figure 6-13.—Through-transmission inspection.

examination of skins for cracks, and inspection of welds. Figure 6-14 shows typical angle-beam inspections.

SURFACE WAVE.—The surface-wave method projects a beam of vibrations that travel along the surface and just below the surface of the material. When surface waves are used to inspect painted surfaces, you should exercise caution during set up and interpretation due to the possibility of surface reflection from scratches and breaks in the painted surface. Surface-wave inspections can be used in many field NDI applications involving surface cracks or slightly subsurface discontinuities. On smooth surfaces, sound energy can travel long distances with little energy loss. Surface waves travel around curved corners, and they reflect at sharp edges. Rough surfaces or liquid on the surface attenuate surface waves so the area in front of the search unit must be kept clear of couplant. Figure 6-15 shows a typical surface-wave inspection.

Eddy Current Inspection

Eddy currents are electrical currents induced in a conductor of electricity by reaction with a magnetic field. The eddy currents are circular in nature, and their paths are oriented perpendicular to the direction of the applied magnetic field. In general, during eddy current testing, the varying magnetic field(s) is/are generated by an alternating electrical current (ac) flowing through a coil of wire positioned immediately adjacent to the conductor, around the conductor, or within the

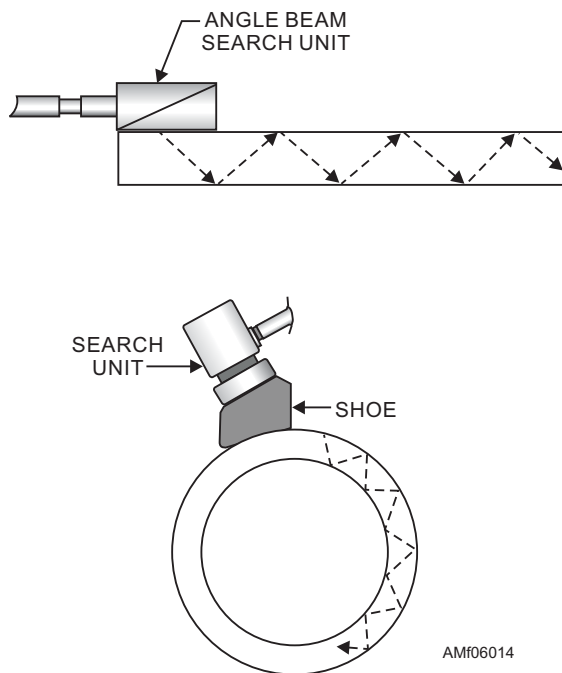

Figure 6-14.—Angle-beam inspection.

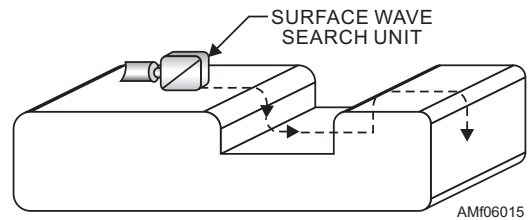

Figure 6-15.—Surface-wave inspection.

conductor. Figure 6-16 shows eddy currents flowing in various configurations.

COILS AND PROBES.—Eddy current coils and probes consist of one or more coils of wire designed to introduce a varying magnetic field into a part to determine the effects of test variables on this magnetic field. Generation of the magnetic field results from an alternating current flowing through the coil. A fundamental consideration in selecting an eddy current probe or test coil is its intended use. A small diameter probe or narrow encircling coil will provide increased resolution of small defects. A larger probe or wider encircling coil will provide better averaging of bulk properties.

TEST COIL CONFIGURATIONS.—Eddy current probes and coils can be classified into three types: surface probes, encircling coils, and inside

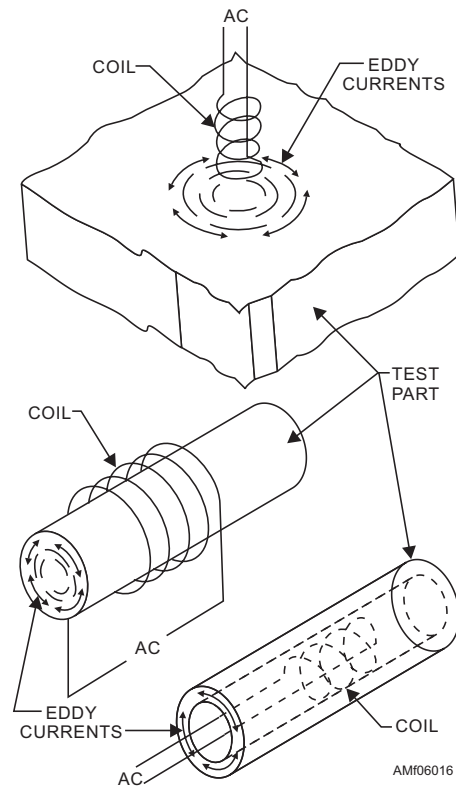

Figure 6-16.—Generation of eddy currents in various part configurations.

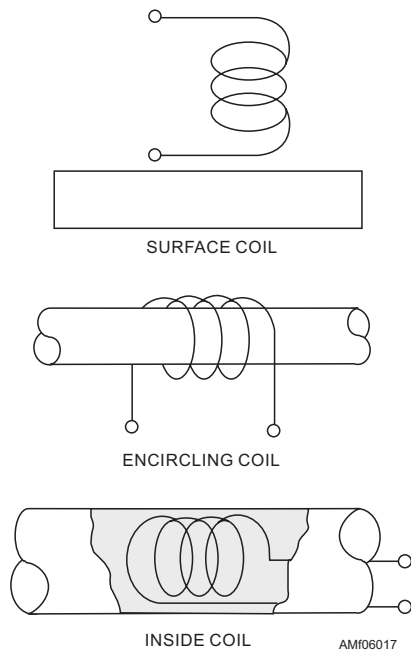

Figure 6-17.—Basic coil configurations.

(bobbin-type) coils. Figure 6-17 shows sketches of the general configuration of each type of coil or probe. Figure 6-18 shows photographs of typical surface probes used for eddy current testing. Most eddy current testing in the field is concerned with surface coils (probes). The surface probe is used on plates, sheets, and irregular-shaped parts. An inside coil may be used on tubes, pipes, or other parts that are accessible to the inside. The inside coil should nearly fill the part opening in order to provide good test sensitivity. The

use of inside coils is restricted by bends or nonuniform diameters. Encircling coils are used primarily for inspecting rods, tubes, cylinders, or wire. With the encircling or inside coils, the entire circumference of the specimen is evaluated at one time. Consequently, the exact location of defects cannot be defined. The surface coil has the ability to better define the exact location of discontinuities.

Dye Penetrant Inspection

The dye penetrant inspection is a simple, inexpensive, and reliable nondestructive inspection method for detecting discontinuities that are open to the surface of the item to be inspected. It can be used on metals and other nonporous materials that are not attacked by penetrant materials. With the proper technique, it will detect a wide variety of discontinuities, ranging in size from those readily visible down to microscopic level, as long as the discontinuities are open to the surface and are sufficiently free of foreign material. Figure 6-19 shows the basic principles of the penetrant inspection process. A penetrating liquid, which contains dyes, is applied to the surface of a clean part to be inspected. The penetrant is allowed to remain on the surface of the part for a period of time to permit it to enter and fill any openings or discontinuities. After a suitable dwell period, the penetrant is removed from the part's surface. You must exercise care to prevent removal of the penetrant that is contained in the discontinuities. A material called

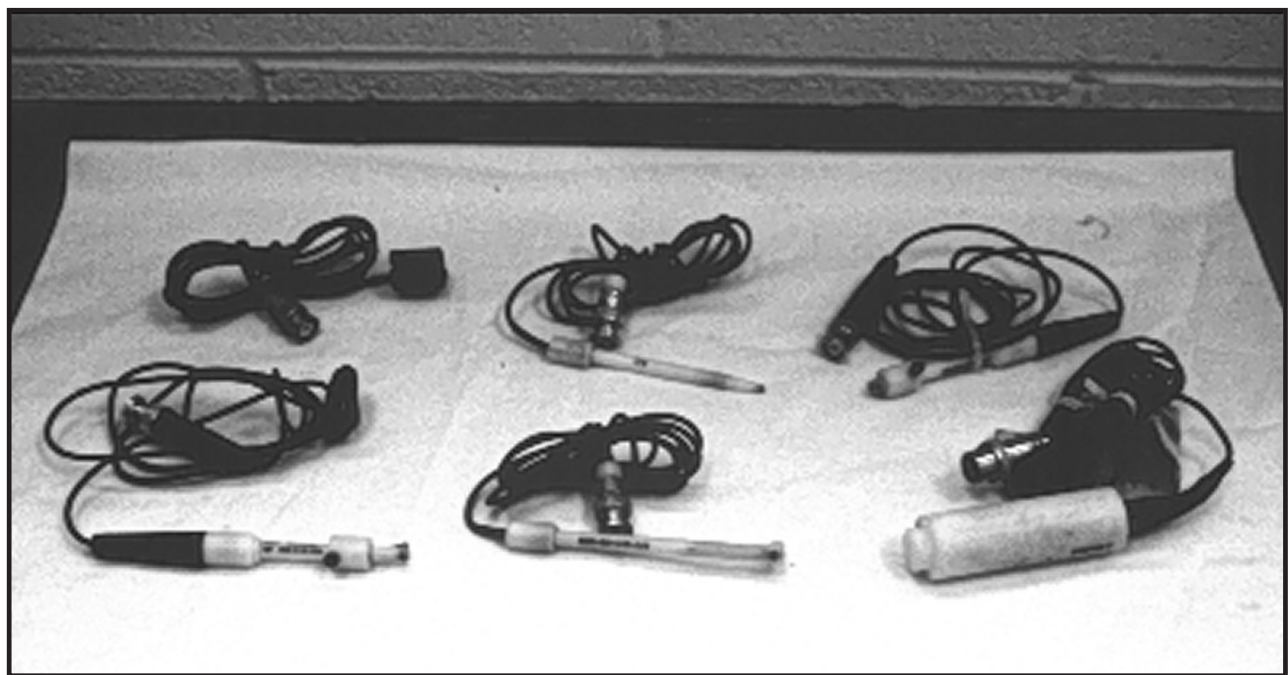

AMf06018

Figure 6-18.—Typical eddy current test probes.

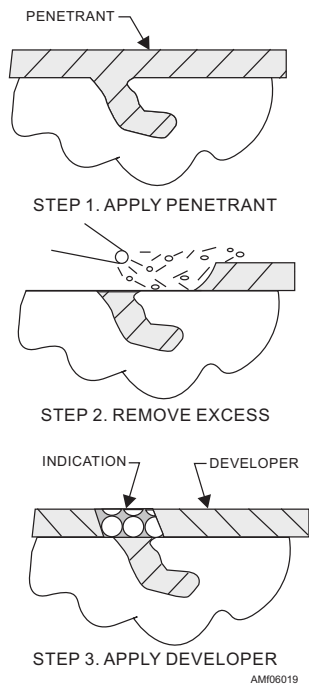

Figure 6-19.—Basic penetrant process.

"developer" is then applied. The developer aids in drawing any trapped penetrant from the discontinuities and improves the visibility of any indications. For more information concerning the dye penetrant inspection, consult the *Nondestructive Inspection Methods Manual*, NAVAIR 01-1A-16.

- Q6-1. According to NA-01-1A-16, who can perform NDI inspections?
- Q6-2. What type of examination must a candidate receive before selection as an NDI inspector and annually thereafter?
- Q6-3. What is the minimum amount of experience required from a technician who is currently certified and engaged in NDI in order to train and certify NDI operators?
- Q6-4. How often must active NDI technicians recertify?
- Q6-5. How often must an NDI technician or operator perform the methods in which they are certified?
- Q6-6. How long must a NDI operator maintain proficiency without being required to update training for recertification?
- Q6-7. The original copy of the NDI certification is held by whom?
- Q6-8. Who verifies the entries in the work center supervisor's Technician/Operator work record?

- Q6-9. What command has cognizance over the NDI program?
- Q6-10. What command provides training for all NADEPs?
- Q6-11. Who is responsible for monitoring the NDI program in activities under their cognizance?
- Q6-12. What activity is responsible for ensuring compliance with qualification requirements and enforcing the Industrial Radiation Safety Program (RASP) requirements in accordance with the RASP manual?
- Q6-13. What division is responsible for monitoring the organization's NDI training program?
- Q6-14. What activity is responsible for requesting NDI inspection on aircraft?
- Q6-15. For a magnetic particle inspection to be performed, a part must be made of alloys that contain a high percentage of what material?
- Q6-16. When conducting a magnetic particle inspection, the magnetic field is interrupted by what factor?
- Q6-17. Which method of magnetization is used to find radial discontinuities around the edges of holes and detect longitudinal discontinuities?
- Q6-18. When you inspect hollow or tubelike parts, it is important to inspect what surface?
- Q6-19. What type of current should be used for the detection of surface discontinuities?
- Q6-20. To detect subsurface discontinuities, you would use direct current with what type of magnetic particle inspection?
- Q6-21. The particles that are used in magnetic particle inspections have what two characteristics?
- Q6-22. The smallest particles are more easily attracted to and held by what type of discontinuities?
- Q6-23. Fluorescent particles are widely used in wet baths and are easily seen on dark backgrounds when what type of light is used?
- Q6-24. What method of inspection is used to detect flaws in areas that are not accessible or favorably oriented for use by other test methods?

- Q6-25. *X-rays can be a health hazard when improperly used because of what factor?*
- Q6-26. *What method of inspection uses vibration or sound waves?*
- Q6-27. *What inspection method is used to detect discontinuities parallel to the test surface on materials one-half inch thick or greater?*
- Q6-28. *What is the best inspection method to use around fastener holes, cylindrical components, and welds?*
- Q6-29. *What ultrasonic method is used to detect surface cracks and subsurface discontinuities in field activities?*
- Q6-30. *Electric currents that are induced in a conductor of electricity by a reaction with a magnetic field are known as what type of currents?*
- Q6-31. *What type of coil has the ability to better define the exact location of discontinuities?*
- Q6-32. *A simple, inexpensive, and reliable method for detecting discontinuities that are open to the surface is known as what type of inspection?*

WELDING

LEARNING OBJECTIVE: Recognize the qualifications and recertification process to become a certified welder. Identify the different types of welding processes. Identify various equipment and materials used in welding.

Welding is the most practical of the many metal-joining processes available to aircraft manufacturers. The welded joint offers rigidity, simplicity, low weight, high strength, and low-cost production equipment. Consequently, welding has been universally adopted in the building of all types of aircraft. Many structural parts, as well as nonstructural parts, are joined by some form of welding, and the repair of these many parts is an indispensable part of aircraft maintenance.

QUALIFICATIONS OF WELDERS

For advancement, you should be familiar with the operation of welding equipment and materials. You should also be able to perform simple welding, brazing, soldering, and cutting operations on ferrous and nonferrous metals.

To weld on aircraft structural parts, you must be a certified welder. To be certified as an aircraft welder, you must pass a qualification test conducted in the presence of a Navy inspector. Passing this test entitles you to a certificate signed by the inspector attesting that you are capable of welding the class of material and type of weld indicated on the certificate.

Naval aviation depots (NADEPs) have training programs for the benefit of those desiring to qualify as aircraft welders, and they have facilities for testing.

RECERTIFICATION OF WELDERS

Only currently certified aeronautical welders may weld on aeronautical equipment. Initial certification is attained by satisfactory completion of Navy training course(s) N-701-0007 and/or N-701-0009, as applicable. Certification can also be obtained by documented satisfactory completion of equivalent training in accordance with *Aeronautical and Support Equipment Welding Manual*, NA 01-1A-34, and satisfactory completion of recertification testing. If proficiency is maintained, the recertification interval for IMA-level aeronautical equipment welders is 3 years. Maintaining proficiency requires documented frequency of use, as specified in NA 01-1A-34. Failure to maintain proficiency in any group(s) of metals will terminate current certification in that/those group(s).

Recertification is normally accomplished by locally producing acceptable test welds and submitting those welds to the nearest authorized welding examination and evaluation facility. Examination and evaluation facilities must complete required testing of test weld specimens and provide test results and recertification documentation, as appropriate, to the affected welder's command within 30 days of the test weld(s) receipt.

Detailed procedures for obtaining test plates, production and submission of test welds, and documentation are contained in NA 01-1A-34. TYCOMs/ACCs may extend current certification of welders for a maximum of 90 days in cases where test welds have been submitted but results and recertification documentation have not been received from the cognizant examination and evaluation facility. Welders whose test specimens fail to meet minimum requirements are allowed one retest. This retest will require submission of a double set of test welds of the failed group(s) of metal(s) to the same examination and evaluation facility that failed the test welds first submitted. Welding examination and evaluation

facilities will forward double sets of test plates to the failed welder's command concurrently with the notification of failure. Retest test welds must be completed and submitted within 30 days of receipt of notification of failure of first test weld(s). Failure of any retest test welds to meet minimum requirements will require the welder to satisfactorily complete the Navy training courses N-701-0008/N-701-0010, as applicable, to recertify.

Aeronautical equipment welders may weld only on equipment, components, and items manufactured from the group of metals for which they are currently certified and for which weld repairs are authorized by applicable technical publications or directives. Groups of metals for which separate and distinct certification is required are specified in NA 01-1A-34. Separate certification is also required for oxyfuel brazing process.

NA 01-1A-34 contains additional information and guidance relative to qualification, certification/recertification, and employment of aeronautical equipment welders. It is, however, a general series technical manual intended to be used in conjunction with the OPNAV 4790.2 and with specific maintenance/repair/overhaul manuals/engineering documents. In cases of conflict between NA 01-1A-34 and the OPNAV 4790.2 regarding certification/recertification policy, the OPNAV 4790.2 takes precedence.

QA/A is responsible for monitoring aeronautical equipment welder certification/recertification. Refer to the OPNAV 4790.2 for specifics.

A Welding Certificate (Operator's Card), DD Form 2758, will be issued for each material category in which the welder is qualified. The welding certificate will be filled out, dated, and signed by an authorized representative of an examination facility. Figure 6-20 provides a sample of the welding certificate. Figures 6-21 and 6-22 show a sample Welding Examination Record (DD Form 2757) and instructions.

OXYACETYLENE WELDING

Oxyacetylene welding is a gas welding process. A coalescence or bond is produced by heating with a gas flame or flames obtained from the combustion of acetylene with oxygen, with or without the application of pressure, and with or without the use of filler metal. A welding torch is used to mix the gases in the proper proportions and to direct the flame against the parts to be welded. The molten edges of the parts then literally flow together and, after cooling, form one solid piece. Usually, it is necessary to add extra material to the joint. The correct material in rod form is dipped in and fuses with the puddle of molten metal from the parent metal parts.

Acetylene is widely used as the combustible gas because of its high flame temperature when mixed with oxygen. The temperature, which ranges from approximately 5,700° to 6,300°F, is so far above the melting point of all commercial metals that it provides a means for the rapid, localized melting essential in welding. The oxyacetylene flame is also used in cutting ferrous metals. The oxyacetylene welding and cutting methods are widely used by all types of maintenance

WELDING CERTIFICATION CARD		PROCESS	METAL GROUP	THICKNESS LIMITATIONS	POSITIONS	INITIAL/STAMP	EXP. DATE
NAME _____	WELDER IDENTIFICATION NO. _____						
Is certified in accordance with NA 01-1A-34/TO 00-25-252/TC 9-238/AWS 82.1 for the welding processes, metal groups, thicknesses and positions that are listed and initialed/stamped on the back of this card.							
DATE _____	AUTHORIZED ENG. LAB SIGNATURE _____						
DATE _____	WELD INSTRUCTOR/INSPECTOR SIGNATURE _____						
CERTIFYING ACTIVITY _____							
DD FORM 2758. JUN 1997							

DD FORM 2758 (BACK), JUN 1997

AMF06020

Figure 6-20.—Welding Certification (DD Form 2758).

WELDING EXAMINATION RECORD							1. DATE	
SECTION I - APPLICATION								
2. NAME (Last, First, Middle Initial)				3. PARENT ORGANIZATION			4. UNIT ADDRESS	
5. QUALIFICATION GROUP			6. RATING/RATE		7. WELDER IDENTIFICATION NUMBER		8. EXPIRATION DATE	
9. WELDING SCHOOL OR SOURCE OF TRAINING				10. WELDING PROCESS				
11. WELDING PROCEDURE SPECIFICATIONS <i>(See Table 3-3 for all parameters. Use a. - n. for special qualifications)</i>			WPS NUMBERS					
a. BASE METAL								
b. FILLER METAL TYPE								
c. FILLER METAL DIAMETER								
d. POSITION								
e. TORCH SHIELDING GAS TYPE								
f. TORCH SHIELDING GAS FLOW								
g. ROOT SHIELDING GAS TYPE								
h. ROOT SHIELDING GAS FLOW								
i. NOZZLE SIZE								
j. CURRENT TYPE								
k. AMPERAGE								
l. ELECTRODE TYPE								
m. ELECTRODE DIAMETER								
n. NUMBER OF PASSES								
12. SIGNATURE OF APPLICANT				13. SIGNATURE OF OBSERVING OFFICIAL. I certify the weld specimen was completed by the applicant using the above procedure.				
SECTION II - EXAMINATION RESULTS								
WPS NUMBERS	TEST SPECIMEN				RETEST SPECIMEN			
	14. VISUAL	15. RADIOGRAPHIC	16. BEND	17. METALLOGRAPHIC	14. VISUAL	15. RADIOGRAPHIC	16. BEND	17. METALLOGRAPHIC
18. REMARKS								
19. TO OBTAIN REQUALIFICATION OPERATOR MUST:								
<input type="checkbox"/> RESUBMIT EXAMINATION			<input type="checkbox"/> ATTEND AUTHORIZED WELDING TRAINING SCHOOL					
20. TESTING OFFICIAL				a. SIGNATURE				
<input type="checkbox"/> QUALIFIED			<input type="checkbox"/> NOT QUALIFIED					
b. ORGANIZATION AND ADDRESS				c. QUALIFICATION GROUP			d. LEVEL (AF only)	
21a. SIGNATURE OF CERTIFYING OFFICIAL							b. DATE CERTIFIED	

Figure 6-21.—Welding Examination Record (DD Form 2757) (front).

INSTRUCTIONS OR COMPLETION OF DD FORM 2757.
WELDING EXAMINATION RECORD

SECTION I:

Block 2 - NAME Self-explanatory.

Block 3 - PARENT ORGANIZATION. Self-explanatory.

Block 4 - UNIT ADDRESS. Self-explanatory.

Block 5 - QUALIFICATION GROUP. Metal groups submitted for certification.

Block 6 - RATING/RATE. Enter military rank or civilian pay number.

Block 7 - WELDER IDENTIFICATION NUMBER. Enter military identification number or civilian pay number.

Block 9 - WELDING SCHOOL OR SOURCE OF TRAINING. Self-explanatory.

Block 10 - WELDING PROCESS. Process used to accomplish the weld.

Block 11 - WELDING PROCEDURE USED. Conditions used in completing test welds will be listed under appropriate WPD number column (See Table 3-3).

Block 12 - SIGNATURE OF APPLICANT. Self-explanatory.

Block 13 - SIGNATURE OF OBSERVING OFFICIAL. Signature of the person observing the certification welding.

Block 14 - 17. The appropriate blocks will be marked either satisfactory (SAT) or unsatisfactory (UNSAT) in accordance with the results of the particular examination.

Block 18 - REMARKS. Record cause of any unsatisfactory results or other relevant information.

Block 19 - TO OBTAIN REQUALIFICATION OPERATOR MUST. Decision made by evaluating activity after failure of previous test specimens.

Block 20 - TESTING OFFICIAL. Annotate whether qualified or not qualified in appropriate box (All DOD). Signature of the official who evaluates the test specimens. Organization and address of testing official.

Block 21 - CERTIFYING OFFICIAL. The welding instructor/inspector who actually certifies the welder at the evaluation laboratory will enter signature and record the effective date of.

DD FORM 2757 (BACK), JUN 1997

AMf06022

Figure 6-22.—Welding Examination Record (DD Form 2757) (back).

activities because the flame is easy to regulate, the gases may be produced inexpensively, and the equipment can be transported easily and safely.

Oxyacetylene Welding Equipment

The equipment used for oxyacetylene welding consists of a source of oxygen and a source of acetylene from a portable or stationary outfit. The portable outfit consists of an oxygen cylinder and an acetylene cylinder with attached valves, regulators, gauges, and hoses (fig. 6-23). This equipment may be temporarily secured on the floor or mounted on a two-wheel, welded, steel truck equipped with a platform that will support two large size cylinders. The cylinders are secured by chains attached to the truck frame. A metal toolbox, welded to the frame, provides storage for torches, tips, gloves, fluxes, goggles, and necessary wrenches.

Stationary equipment is installed where welding operations are conducted in a fixed location. The acetylene and oxygen are piped to several welding stations from a central supply. Master regulators are used to control the flow of gas and maintain a constant pressure at each station.

OXYGEN.—Oxygen is a colorless, tasteless, odorless gas that is slightly heavier than air. Oxygen is

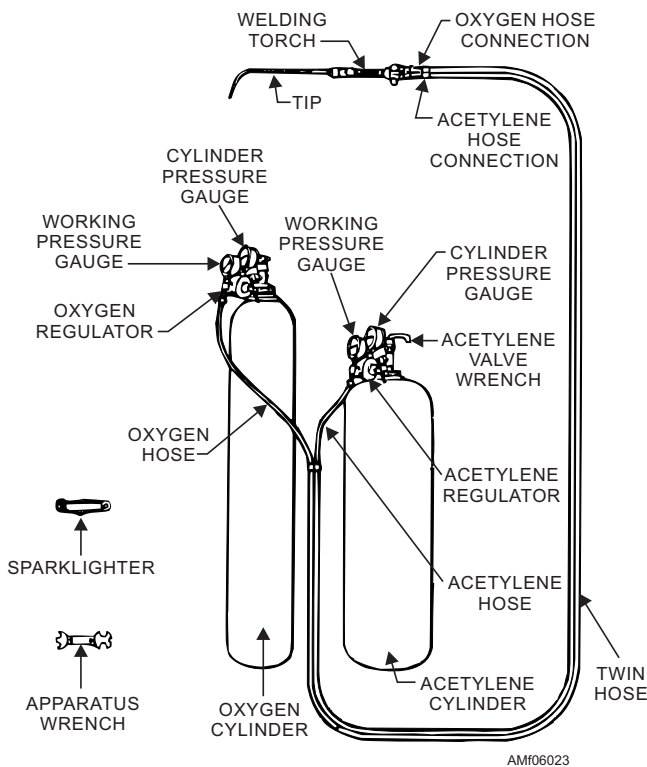

Figure 6-23.—Portable oxyacetylene welding and cutting equipment.

nonflammable, but it will support combustion when combined with other gases. This means that it aids in burning, and this burning gives off considerable heat and light. In its free state, oxygen is one of the most common elements. The atmosphere is made up of approximately 21 parts of oxygen and 78 parts of nitrogen, with the remainder being rare gases. It is the presence of oxygen in the air that causes rusting of ferrous metals, the discoloration of copper, and corrosion of aluminum. This action is known as oxidation.

Oxygen is obtained commercially either by the liquid air process or by the electrolytic process. In the liquid air process, air is compressed and cooled to a point where the gases become a liquid. As the temperature of the liquid air is raised, nitrogen in a gaseous form is given off first, since its boiling point is lower than that of liquid oxygen. These gases, having been separated, are further purified and compressed into cylinders for use.

In the electrolytic process, water is broken down into hydrogen and oxygen by the passage of an electric current through it. The oxygen collects at the positive terminal and the hydrogen at the negative terminal. Each of the gases is then collected and compressed into cylinders for use.

OXYGEN CYLINDERS.—A typical oxygen cylinder (fig. 6-24) is made of steel and has a capacity

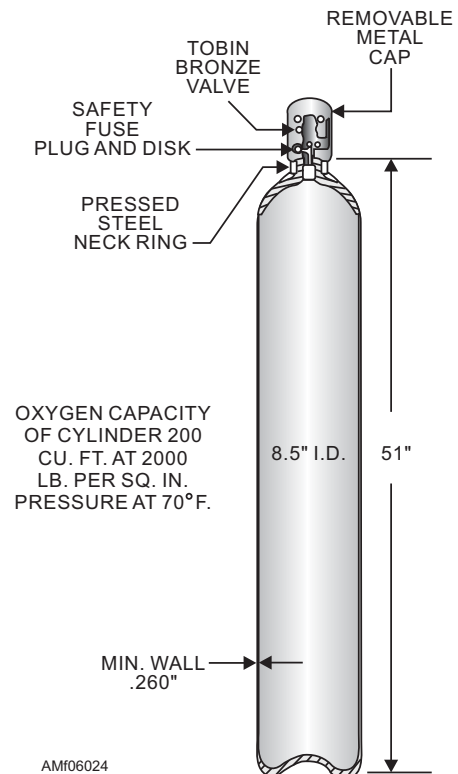

Figure 6-24.—Typical oxygen cylinder.

of 220 cubic feet at a pressure of 2,000 psi and a temperature of 70°F. Each oxygen cylinder has a high-pressure outlet valve located at the top of the cylinder, a removable metal cap for the protection of the outlet valve during shipment or storage, and a low melting point safety fuse plug and disk. All oxygen cylinders are painted green for identification. Technical oxygen cylinders are solid green, while breathing oxygen cylinders are green with a white band around the top.

CAUTION

Oxygen should never be brought in contact with oil or grease. In the presence of pure oxygen, these substances become highly combustible. Oxygen hose and valve fittings should never be oiled or greased or handled with oily or greasy hands. Even grease spots on clothing may flare up or explode if struck by a stream of oxygen.

PRESSURE REGULATORS.—The gases compressed in oxygen and acetylene cylinders are at pressures too high for oxyacetylene welding. Regulators are necessary to reduce pressure and control the flow of gases from the cylinders. Most regulators in use are either the single-stage or the two-stage type. Single-stage regulators reduce the pressure of the gas in

one step; two-stage regulators do the same job in two steps or stages. Generally, less adjustment is necessary when two-stage regulators are used.

Figure 6-25 shows a typical single-stage regulator. The regulator mechanism consists of a nozzle through which the high-pressure gases pass, a valve seat to close off the nozzle, and balancing springs. These are all enclosed in a suitable housing. Pressure gauges are provided to indicate the pressure in the cylinder or pipeline (inlet), as well as the working pressure (outlet). The inlet pressure gauge, used to record cylinder pressures, is a high-pressure gauge and is graduated from 0 to 3,000 psi. The outlet pressure gauge, used to record working pressures, is a low-pressure gauge and is graduated from 0 to 500 psi.

In the oxygen regulator, the oxygen enters through the high-pressure inlet connection and passes through a glass wool filter that removes dust and dirt. Turn the adjusting screw in, to the right, to allow the oxygen to pass from the high-pressure chamber to the low-pressure chamber of the regulator, through the regulator outlet, and through the hose to the torch at the pressure shown on the working pressure gauge. Changes in this pressure may be made at will, simply by adjusting the handle until the desired pressure is registered. Turning the adjusting screw to the right **INCREASES** the working pressure; turning it to the left **DECREASES** the working pressure.

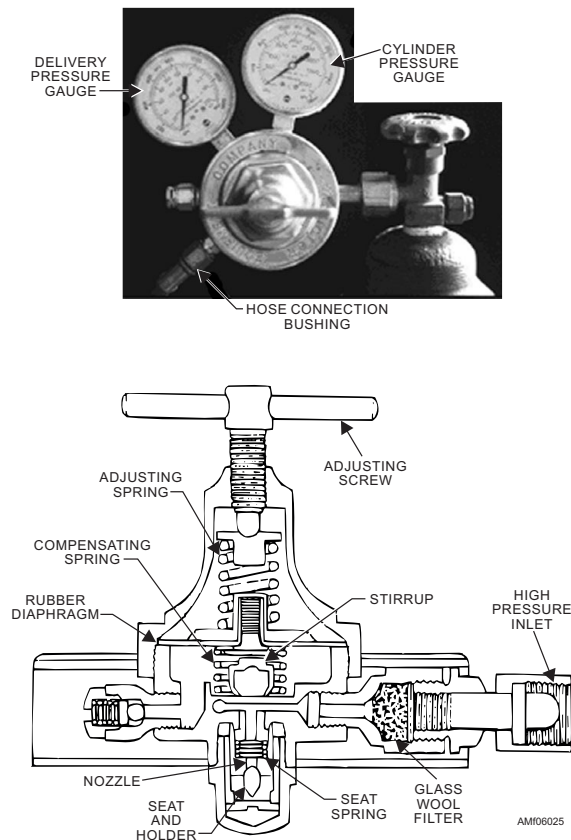

Figure 6-25.—Single-stage oxygen regulator.

The operation of the two-stage regulator is similar in principle to the single-stage regulator. The difference is that the total pressure decrease takes place in two steps instead of one. On the high-pressure side, the pressure is reduced from cylinder pressure to intermediate pressure. On the low-pressure side, the pressure is reduced from intermediate pressure to working pressure. Because of the two-stage pressure control, the working pressure is held constant, and pressure adjustment during welding operations is not required. A two-stage regulator is shown in figure 6-26.

The acetylene regulator controls and reduces the acetylene pressure from any standard cylinder that contains pressures up to 500 psi. It is of the same general design as the oxygen regulator, but it will not withstand such high pressures. The high-pressure gauge, on the inlet side of the regulator, is graduated from 0 to 500 psi. The low-pressure gauge, on the outlet side of the regulator, is graduated from 0 to 30 psi. Acetylene should not be used at pressures exceeding 15 psi.

ACETYLENE.—Acetylene is a fuel gas made up of carbon and hydrogen. It is manufactured by the chemical reaction between calcium carbide, a gray stone like substance, and water in a generating unit. Acetylene is colorless, but it has a distinctive odor that can be easily detected.

Mixtures of acetylene and air that contain from 2 to 80 percent of acetylene by volume will explode when ignited. However, with suitable welding equipment and proper precautions, acetylene can be safely burned with oxygen for welding and cutting purposes. When burned with oxygen, acetylene produces a very hot flame that has a temperature between 5,700°F and 6,300°F.

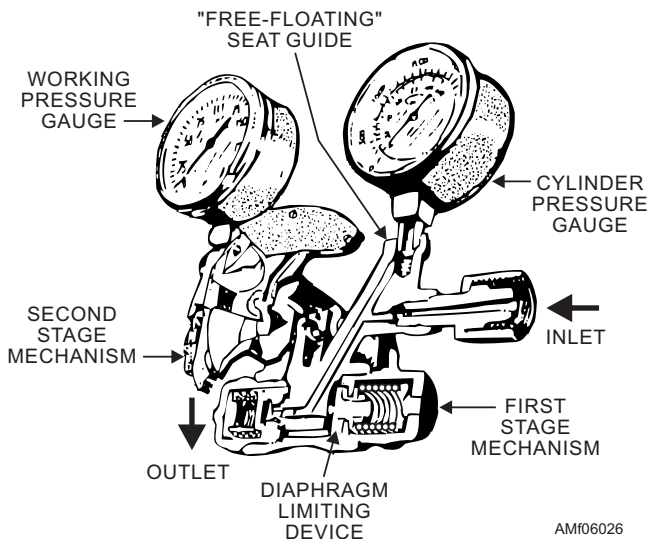

Figure 6-26.—Two-stage regulator.

ACETYLENE CYLINDERS.—Acetylene stored in a free state under pressure greater than 15 psi can be made to break down by heat or shock, and possibly explode. Under pressure of 29.4 psi, acetylene becomes self-explosive, and a slight shock will cause it to explode spontaneously. However, when dissolved in acetone, it can be compressed into cylinders at pressures up to 250 psi.

The acetylene cylinder (fig. 6-27) is filled with porous materials, such as balsa wood, charcoal, and shredded asbestos, to decrease the size of the open spaces in the cylinder. Acetone, a colorless, flammable liquid, is added until about 40 percent of the porous material is filled. The filler acts as a large sponge to absorb the acetone, which, in turn, absorbs the acetylene. In this process, the volume of the acetone increases as it absorbs the acetylene, while acetylene, being a gas, decreases in volume. The acetylene cylinders are equipped with safety plugs, which have a small hole through the center. This hole is filled with a metal alloy, which melts at approximately 212°F or releases at 500 psi. When a cylinder is overheated, the plug will melt and permit the acetylene to escape before a dangerous pressure can build up. The plughole is too small to permit a flame to burn back into the cylinder if the escaping acetylene should become ignited.

WELDING TORCHES.—The oxyacetylene welding torch is used to mix oxygen and acetylene gas in the proper proportions, and to control the volume of these gases burned at the welding tip. The torch has two needle valves, one for adjusting the flow of acetylene

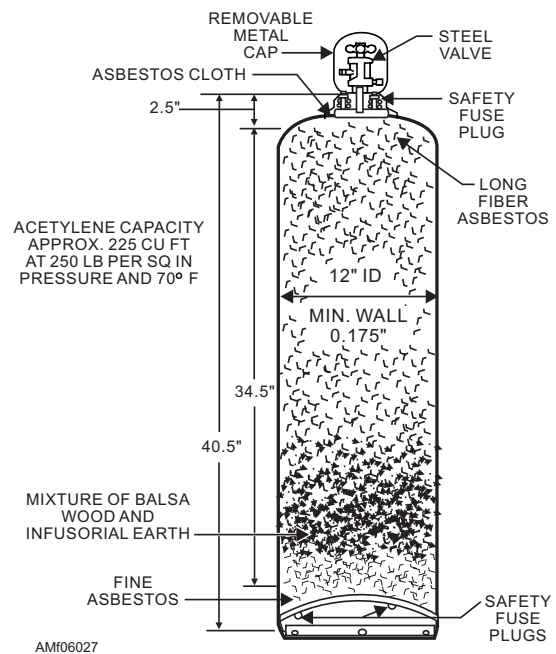

Figure 6-27.—Acetylene cylinder.

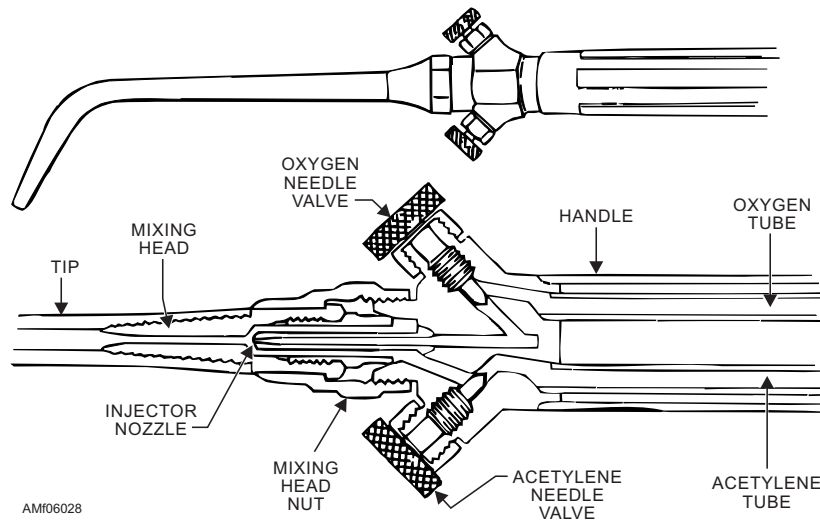

Figure 6-28.—Mixing head for injector-type welding torch.

and the other for adjusting the flow of oxygen. In addition, there are two tubes, one for oxygen and the other for acetylene; a mixing head; inlet nipples for the attachment of hoses; a tip; and a handle. The tubes and handle are made of seamless hard brass, copper-nickel alloy, stainless steel, or other noncorrosive metals of adequate strength.

There are two types of welding torches—the low-pressure or injector type and the equal-pressure type. In the low-pressure or injector type (fig. 6-28), the acetylene pressure is less than 1 psi. A jet of high-pressure oxygen is used to produce a suction effect to draw in the required amount of acetylene. This is accomplished by the design of the mixer in the torch, which operates on the injector principle. The welding tips may or may not have separate injectors designed integrally with each tip.

The equal pressure torch (fig. 6-29) is designed to operate with equal pressures for the oxygen and acetylene. The pressure ranges from 1 to 15 psi. This torch has certain advantages over the low-pressure type because the flame can be more readily adjusted, and since equal pressures are used for each gas, the torch is less susceptible to flashbacks.

The welding tips are made of hard, drawn, electrolytic copper or 95-percent copper and 5-percent tellurium. They are made in various styles and types, some having a one-piece tip either with a single orifice or a number of orifices, and others with two or more tips attached to one mixing head. The diameters of the tip orifices differ to control the quantity of heat and the type of flame. These tip sizes are designated by numbers that are arranged according to the individual

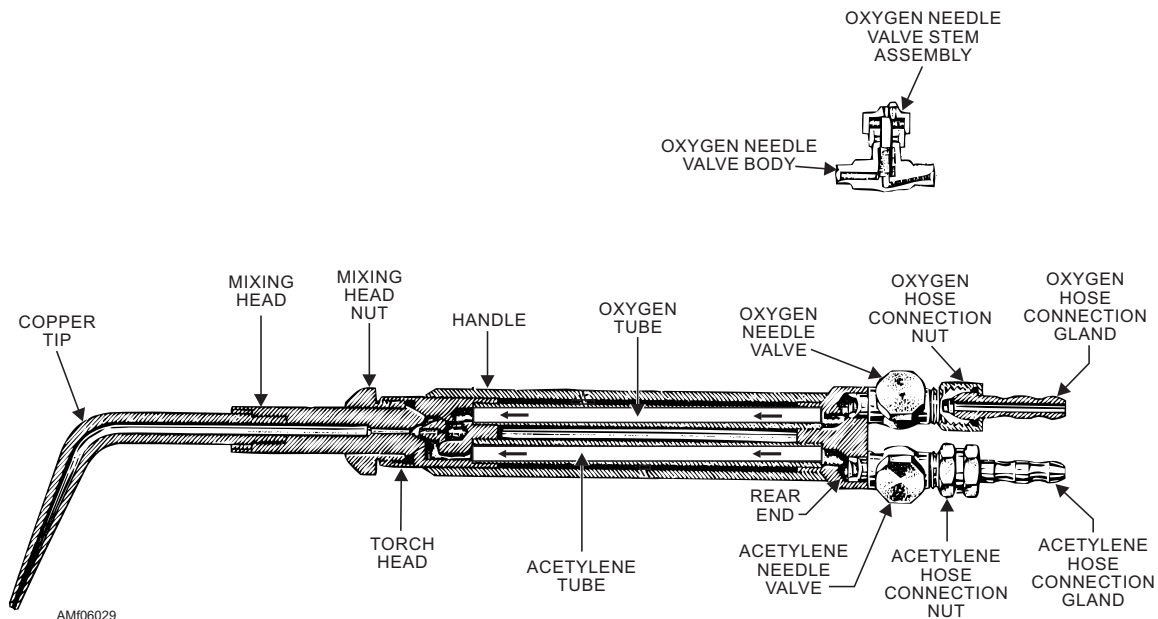

Figure 6-29.—Equal pressure welding torch.

manufacturer's system. In general, the smaller the number, the smaller the tip orifice.

No matter what type or size tip you select, the tip must be kept clean. Quite often the orifice becomes clogged with slag. When this happens, the flame will not burn properly. Inspect the tip before you use it. If the passage is obstructed, you can clear it with wire tip cleaners of the proper diameter, or with soft copper wire. Tips should not be cleaned with machinist's drills or other sharp instruments. These devices may enlarge or scratch the tip opening and greatly reduce the efficiency of the torch tip.

HOSE.—The hose used to make the connection between the torch and the regulators is strong, nonporous, light, and flexible to make the torch movements easy. It is made to withstand high internal pressures, and the rubber used in its manufacture is chemically treated to remove sulfur to avoid the danger of spontaneous combustion.

The oxygen hose is GREEN, and the acetylene hose is RED. The hose is a rubber tube with braided or wrapped cotton or rayon reinforcements and a rubber covering. The hoses have connections at each end so they can be connected to their respective regulator outlet and torch inlet connections. To prevent a dangerous interchange of acetylene and oxygen hoses, all threaded fittings used for the acetylene hookup are left-handed threads, and all threaded fittings for oxygen hookup are right-handed threads. The hoses are obtainable as a single hose for each gas or with the hoses bonded together along their length under a common outer rubber jacket. This type prevents the hose from kinking or becoming entangled during the welding operation.

LIGHTERS.—A flint lighter is provided for igniting the torch. The lighter consist of a file-shaped piece of steel, usually recessed in a cuplike device, and a piece of flint that can be drawn across the steel, which produces the sparks required to light the torch.

WARNING

Matches should never be used to ignite a torch; their length requires bringing the hand too close to the tip to ignite the gas. Accumulated gas may envelope the hand and, when ignited, cause a severe burn.

GOGGLES.—Welding goggles are fitted with colored lenses to keep out heat and light rays and to

protect the eyes from sparks and molten metal. Regardless of the shade of lens used, goggles should be protected by a clear cover glass. The welding operator should select the shade or density of color that is best suited for his/her particular work. The desired lens is the darkest shade that will show a clear definition of the work without eyestrain. Goggles should fit closely around the eyes, and should be worn at all times during welding and cutting operations. Special goggles, using standard lenses, are available for use with spectacles.

WELDING (FILLER) RODS.—The use of the proper type of filler rod is very important in oxyacetylene welding operations. This material not only adds reinforcement to the weld area, but also adds desired properties to the finished weld. By selecting the proper type of rod, either tensile strength or ductility can be secured in a weld. Similarly, rods can be selected that will help retain the desired amount of corrosion resistance. In some cases, a suitable rod with a lower melting point will eliminate possible cracks from expansion and contraction.

Welding rods are classified as ferrous and nonferrous. The ferrous rods include carbon and alloy steel rods as well as cast iron rods. Nonferrous rods include brazing and bronze rods, aluminum and aluminum alloy rods, magnesium and magnesium alloy rods, copper rods, and silver rods. The diameter of the rod used is governed by the thickness of the metals being joined. If the rod is too small, it will not conduct heat away from the puddle rapidly enough, and a burned weld will result. A rod that is too large will chill the puddle. As in selecting the proper size welding torch tip, experience will enable the welder to select the proper diameter welding rod.

Welding Flames

The welding flame is classified as neutral, carburizing, or oxidizing. Each type of flame has its own special function. The operator can adjust the torch to produce the type of flame best suited for the job at hand.

The neutral flame, in which a balanced mixture of oxygen and acetylene is burned, is used for most welding operations. The oxidizing flame, in which an excess of oxygen is burned, is used for welding bronze or fusing brass and bronze. The carburizing flame, in which an excess of acetylene is burned, is used when welding nickel alloys.

NEUTRAL FLAME.—The neutral flame does not alter the composition of the base metal to any great

extent; therefore, it is the flame best suited for most metals. The neutral flame burns at approximately 5,850°F. A balanced mixture of one volume of oxygen and one volume of acetylene is supplied from the torch when the flame is adjusted to neutral.

The neutral flame is divided into two distinct zones. The inner zone consists of a white, clearly defined, round, smooth cone, 1/16 to 3/4 inch in length. The outer zone, made up of completely burned oxygen and acetylene, is blue with a purple tinge at the point and edges.

A neutral flame melts metal without changing its properties, and it leaves the metal clear and clean. If the mixture of oxygen and acetylene is correct, the neutral flame allows the molten metal to flow smoothly, and few sparks are produced when welding most metals.

CARBURIZING FLAME.—The carburizing flame, produced by burning an excess of acetylene, may be recognized by its three distinct colors. There is a bluish-white inner core, a white intermediate cone, and a light-blue outer flame. It may be recognized also by the feather at the tip of the inner cone. The degree of carburization can be judged by the length of the feather.

OXIDIZING FLAME.—The oxidizing flame is produced by burning an excess of oxygen. It has the general appearance of the neutral flame, but the inner cone is shorter, slightly pointed, and has a purplish tinge. This flame burns with a hissing sound. When welding ferrous metals, you can recognize an oxidizing flame by the numerous sparks that are thrown off as the metal melts and by the foam that forms on the surface.

FLAME ADJUSTMENT.—To adjust the flame, light the torch by opening the torch acetylene valve one-fourth to one-half turn. With only the acetylene valve open, the flame will be yellow in color and give off smoke and soot.

Now open the torch oxygen valve slowly. The flame will gradually change in color from yellow to blue, and it will show the characteristics of the excess acetylene flame described earlier.

With most torches, there will be a slight excess of acetylene when the oxygen and acetylene valves are wide open and the recommended pressures are being used. Now close the acetylene valve on the torch slowly. You will notice that the secondary cone gets smaller until it finally disappears completely. Just at this point of complete disappearance, the neutral flame is formed.

To see the effect of an excess of oxygen, close the acetylene valve still further. A change will be noted, although it is by no means as sharply defined as that between the neutral and excess acetylene flames. The entire flame will decrease in size, and the inner cone will become much less sharply defined.

Because of the difficulty in making a distinction between the excess oxygen and neutral flames, an adjustment of the flame to neutral should always be made from the excess acetylene side. Always adjust the flame first so that it shows the secondary cone characteristic of excess acetylene; then, increase the flow of oxygen until this secondary cone just disappears.

During actual welding operations, where a neutral flame is essential, the flame should be checked occasionally to make certain it is neutral. This is accomplished by momentarily withdrawing the torch from the work and increasing the amount of acetylene until a distinctive feathery edge appears on the inner cone. Then, slowly decrease the amount of acetylene until a well-defined cone, characteristic of the neutral flame, is formed.

With each size of tip, a neutral, oxidizing, or carburizing flame can be obtained. It is also possible to obtain a "harsh" or "soft" flame by increasing or decreasing the pressure of both gases.

For most regulator settings, the gases are expelled from the torch tip at a relatively high velocity, and the flame is called "harsh." For some work it is desirable to have a "soft" or low-velocity flame without a reduction in thermal output. This may be achieved by using a larger tip and closing the needle valves until the neutral flame is quiet and steady. It is especially desirable to use a soft flame when welding aluminum, to avoid blowing holes in the metal when the puddle is formed.

BACKFIRE AND FLASHBACK.—Improper handling of the torch may cause the flame to backfire or, in very rare cases, to flashback. A backfire is a momentary backward flow of the gases at the torch tip, causing the flame to go out. Sometimes the flame may immediately come on again, but a backfire is always accompanied by a snapping or popping noise. A backfire may be caused by touching the tip against the work, by overheating the tip, by operating the torch at other than recommended pressures, by a loose tip or head, or by dirt or slag in the end of the tip. A backfire is rarely dangerous, but the molten metal may be splattered when the flame pops.

A flashback is the burning of the gases within the torch, and it is dangerous. It is usually caused by loose connections, improper pressures, or overheating of the torch. A shrill hissing or squealing noise accompanies a flashback; and unless the gases are turned off immediately, the flame may burn back through the hose and regulators and cause great damage. The cause of a flashback should always be determined, and the trouble remedied before relighting the torch.

Fundamental Welding Techniques

The composition, thickness, shape, and position of the metal to be welded govern the techniques to be used. The fundamental techniques include holding the torch, forehand welding, and backhand welding.

HOLDING THE TORCH.—The proper method to use in holding the torch depends upon the thickness of the metal being welded. For light gauge metal, hold the torch as shown in figure 6-30, with the hose draped over the wrist. For heavier work, hold the torch as shown in figure 6-31.

Hold the torch so that the tip is in line with the joint to be welded, and inclined between 30° and 60° from the perpendicular. The exact angle depends upon the type of weld to be made, the amount of preheating necessary, and the thickness and type of metal. The thicker the metal, the more vertical the torch must be for proper heat penetration. The white cone of the flame should be held about 1/8 inch from the surface of the base metal.

If the torch is held in the correct position, a small puddle of molten metal will form. The puddle should be

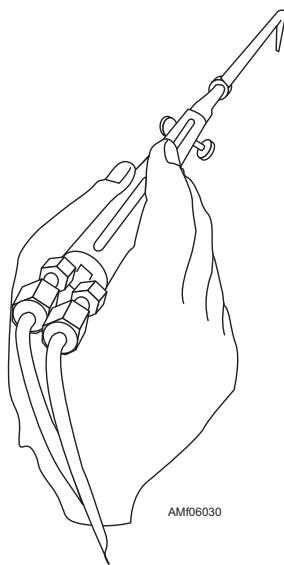

Figure 6-30.—Welding light gauge metals.

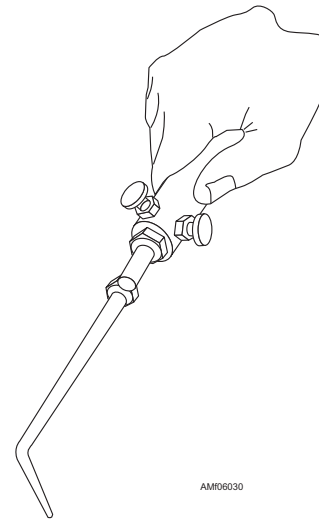

Figure 6-31.—Welding heavy plate.

composed of equal parts of the two pieces being welded. After the puddle appears, begin the movement of the tip in a semicircular or circular motion. This movement assures an even distribution of heat on both pieces of metal. The speed and motion of the torch are learned only by practice and experience.

FOREHAND WELDING.—Forehand (also called "puddle welding" or "ripple welding") is the oldest method of welding. The rod is kept ahead of the tip in the direction in which the weld is being made. Point the flame in the direction of the weld, and hold the tip at an angle of about 45° to 60° to the plates (fig. 6-32). This position of the flame preheats the edges you are welding just ahead of the molten puddle. By moving the tip and welding rod back and forth in opposite semicircular paths, you balance the heat to melt the end of the rod and the sidewalls of the joint into a uniformly distributed molten puddle. As the flame passes the rod, it melts off a short length of the rod and adds it to the puddle. The motion of the torch distributes the molten metal evenly to both edges of the joint and to the molten

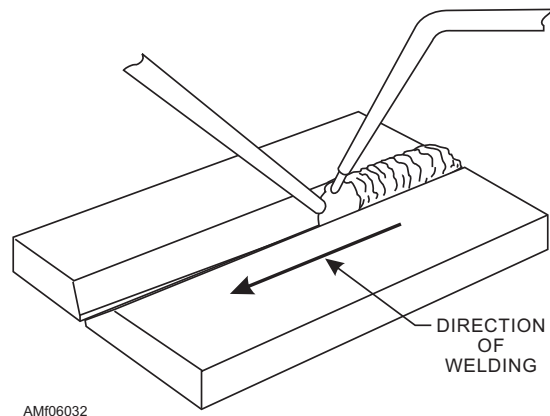

Figure 6-32.—Forehand welding.

puddle. This method is used in welding most of the lighter tubing and sheet metals up to 1/8 inch thick because it permits better control of a small puddle and results in a smoother weld. The forehand technique is not the best method for welding heavy metals.

BACKHAND WELDING.—In this method the torch tip precedes the rod in the direction of welding, and the flame is pointed back at the molten puddle and the completed weld. The end of the rod is placed between the torch tip and the molten puddle. The welding tip should make an angle of about 45° to 60° with the plates or joint being welded (fig. 6-33).

Less motion is required in the backhand method than in the forehand method. If you use a straight welding rod, it should be rotated so that the end will roll from side to side and melt off evenly. You may also bend the rod and, when welding, move the rod and torch back and forth at a rapid rate. If you are making a large weld, you should move the rod so as to make complete circles in the molten puddle. The torch is moved back and forth across the weld while it is advanced slowly and uniformly in the direction of the weld. You'll find the backhand method best for welding material more than 1/8 inch thick. You can use a narrower "V" at the joint than is possible in forehand welding. An included angle of 60° is a sufficient angle of bevel to get a good joint. It doesn't take as much welding rod or puddling for the backhand method as it does for the forehand method.

By using the backhand technique on heavier material, it is possible to obtain increased welding speeds, better control of the larger puddle, and more complete fusion at the root of the weld. Further, by using a reducing flame with the backhand technique, a smaller amount of base metal is melted while welding a joint. Backhand welding is seldom used on sheet metal

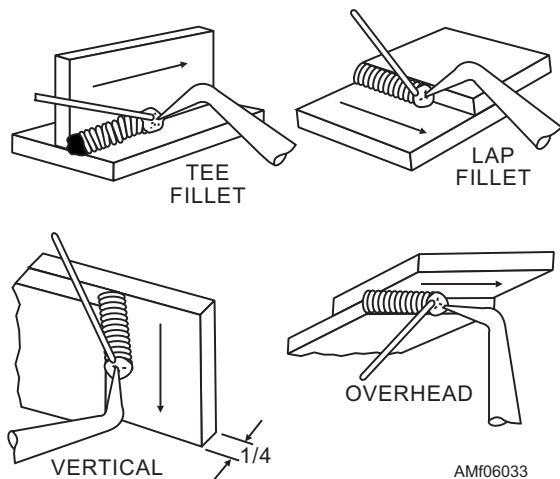

Figure 6-33.—Backhand welding.

because the increased heat generated in this method is likely to cause overheating and burning. When welding steel with a backhand technique and a reducing flame, the absorption of carbon by a thin surface layer of metal reduces the melting point of the steel. This speeds up the welding operation.

WELDING POSITIONS.—The four basic welding positions are shown in figure 6-34. Also shown are four commonly used joints. Notice that the corner joint and butt joint are classified as groove welds, while the tee and lap joints are classified as fillet welds.

Welding is always done in the flat position whenever possible. The puddle is much easier to control, and the welder can work longer periods without tiring. Quite often it is necessary to weld in the overhead, vertical, or horizontal position in equipment repair.

The flat position is used when the material is to be laid flat or almost flat and welded on the topside. The welding torch is pointed downward toward the work. This weld may be made by either the forehand or backhand technique.

The overhead position is used when the material is to be welded on the underside, with the torch pointed upward toward the work. In welding overhead, you can keep the puddle from sagging if you do not permit it to get too large or assume the form of a large drop. The rod is used to control the molten puddle. You should not permit the volume of flame to exceed that required to obtain a good fusion of the base metal with the filler rod. Less heat is required in an overhead weld because the heat naturally rises.

	POSITION OF WELDING			
	FLAT	HORIZONTAL	VERTICAL	OVERHEAD
GROOVE WELDS	BUTT			
	CORNER			
FILLET WELDS	TEE			
	LAP			

AMF06034

Figure 6-34.—Four basic welding positions.

The horizontal position is used when the line of the weld runs horizontal across a piece of work, and the torch is directed at the material in a horizontal or near horizontal position. The weld is made from right to left across the plate (for the right-hand welder). The flame is inclined upward at an angle of 45° to 65°, and the weld is made with a normal forehand technique. Adding the rod to the top of the puddle will prevent the molten metal from sagging to the lower edge of the bead. If the puddle is to have the greatest possible cohesion, it should not be allowed to get too hot.

In a vertical weld, the pressure exerted by the torch flame must be relied upon to a great extent to support the puddle. It is important to keep the puddle from becoming too hot, and to prevent the hot metal from running out of the puddle onto the finished weld. It may be necessary to remove the flame from the puddle for an instant to prevent overheating, and then return it to the puddle. Vertical welds are begun at the bottom, and the puddle is carried upward with a forehand motion. The tip should be inclined from 45° to 60°, the exact angle depending upon the desired balance between correct penetration and control of the puddle. The rod is added from the top and in front of the flame with a normal forehand technique.

Welded Joints

The properties of a welded joint depend partly on the correct preparation of the edges being welded. All mill scale, rust, oxides, and other impurities must be removed from the joint edges or surfaces to prevent their inclusion in the weld metal. You should prepare the edges to permit fusion without excessive melting, and you should take care to keep to a minimum the heat loss due to radiation into the base metal from the weld. A properly prepared joint will give a minimum of expansion on heating and a minimum of contraction on cooling.

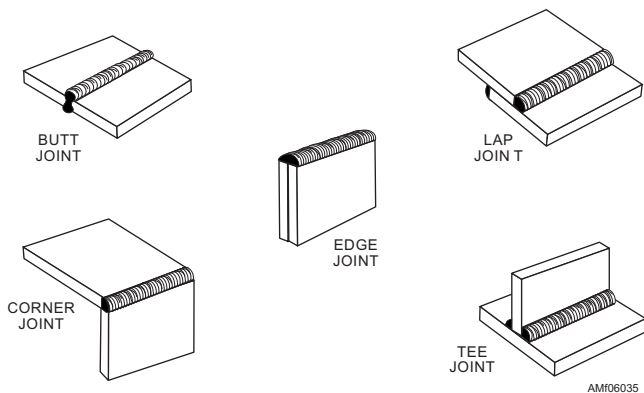

Figure 6-35.—Types of welded joints.

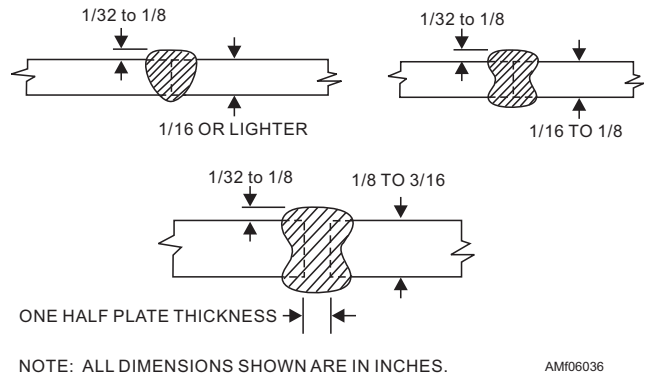

Figure 6-36.—Butt joints in light sections.

The preparation of the metal for welding is governed by the form, thickness, kind of metal, the load that the weld will be required to support, and the available means for preparing the edges to be joined.

The five basic types of welded joints are the butt, tee joints, lap, edge, and corner. (See fig. 6-35.)

BUTT JOINTS.—A butt joint is made by placing two pieces of material edge to edge so there is no overlapping, and then welding them together. Plain, square butt joints used for butt welding thin sheet metal are shown in figure 6-36. Butt joints for thicker metals, with several types of edge preparation, are shown in figure 6-37. These edges can be prepared by flame cutting, shearing, flame grooving, machining, or grinding.

Plate thicknesses of 3/8 to 1/2 inch can be welded by using the single-V or single-U joints, as shown in views A and C of figure 6-37. The edges of heavier sections should be prepared as shown in views B and D of figure 6-37. The single-U groove is more satisfactory and requires less filler metal than the single-V groove when welding heavy sections and when welding in deep sections. The double-V groove joint requires approximately one-half the amount of filler metal used

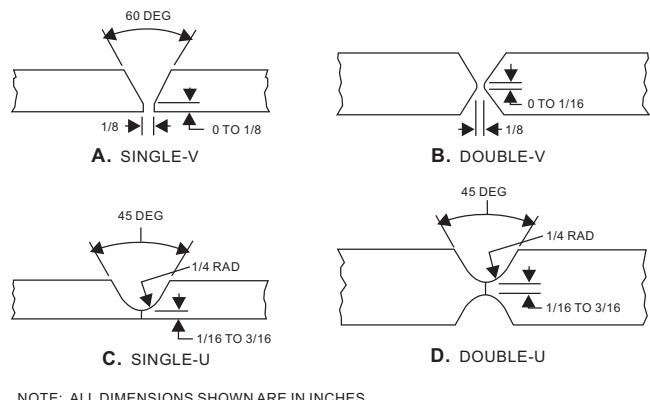

Figure 6-37.—Butt joints in heavy sections.

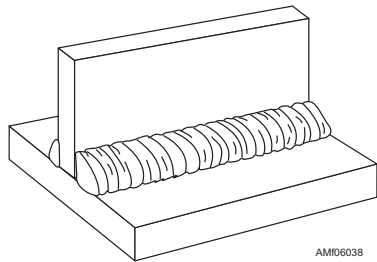

Figure 6-38.—Tee joint—single pass fillet weld.

to produce the single-V groove joint for the same plate thickness. In general, butt joints prepared from both sides permit easier welding, produce less distortion, and ensure better weld qualities in heavy sections than joints prepared from one side only.

TEE JOINTS.—Tee joints are used to weld two plates or sections whose surfaces are located approximately 90° to each other at the joint. A plain tee joint welded from both sides is shown in figure 6-38. The included angle of bevel in the preparation of tee joints is approximately half that required for butt joints.

Other edge preparations used in tee joints are shown in figure 6-39. A plain tee joint, which requires no preparation other than cleaning the end of the vertical plate, and the surface of the horizontal plate is shown in view A of figure 6-39. The single-beveled joint (view B of fig. 6-39) is used in plates and sections up to 1/2 inch thick. The double-bevel joint (view C of fig. 6-39) is used on heavy plates that can be welded from both sides. The single-J joint (view D of fig. 6-39) is used for welding plates that are 1 inch thick or heavier where welding is done from one side. The double-J joint (view E of fig. 6-39) is used for welding very heavy plates from both sides.

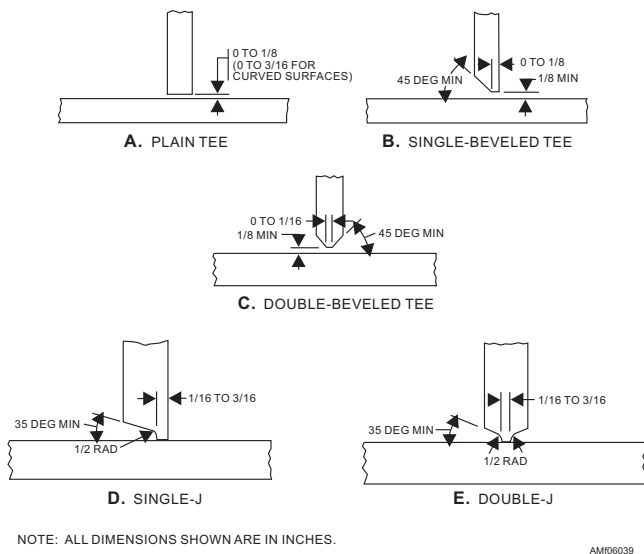

Figure 6-39.—Edge preparations for tee joint.

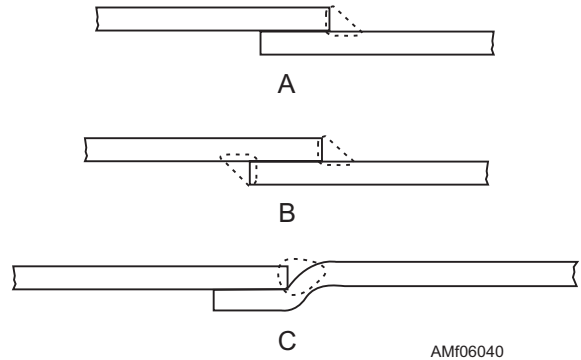

Figure 6-40.—Lap joints.

You must take care to ensure penetration into the root of the weld. This penetration is promoted by root openings between the ends of the vertical members and the horizontal surfaces.

LAP JOINTS.—Lap joints are used to join two overlapping members. A single lap joint, where welding must be done from one side, is shown in view A of figure 6-40. The double lap joint is welded on both sides and develops the full strength of the welded members (view B of fig. 6-40). An offset lap joint (view C of fig. 6-40) is used where two overlapping plates must be joined and welded in the same plane. This type of joint is stronger than the single lap type, but is more difficult to prepare.

EDGE JOINTS.—Edge joints are used to join two or more parallel or nearly parallel members. Edge joints are not very strong, and are used to join edges of sheet metal, reinforcing plates in flanges of I-beams, and for edges of angles. Two parallel plates are joined together, as shown in view A of figure 6-41. On heavy plates,

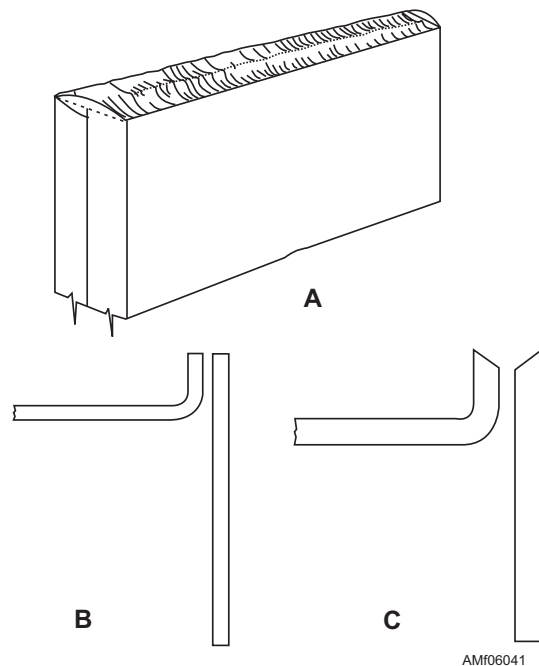

Figure 6-41.—Edge joints for light sheets and plates.

sufficient filler metal is added to fuse or melt each plate edge completely and to reinforce the joint.

Light sheets are welded as shown in view B of figure 6-41. No preparation is necessary other than to clean the edges and tack weld them in position. The edges are fused together so no filler metal is required. The heavy plate joint, as shown in view C of figure 6-41, requires that the edges be beveled to secure good penetration and fusion of the sidewalls. Filler metal is used in this joint.

CORNER JOINTS.—Corner joints are used to join two members located approximately at right angles to each other in the form of an L. The fillet weld corner joint (view A of fig. 6-42) is used in the construction of boxes, box frames, and similar fabrications.

The closed corner joint (view B of fig. 6-42) is used on lighter sheets when high strength is not required at the joint. In making the joint by oxyacetylene welding, the overlapping edge is melted down, and little or no filler metal is added. When the closed joint is used for heavy sections, the lapped plate is V-beveled or U-grooved to permit penetration to the root of the joint.

The open corner joint (view C of fig. 6-42) is used on heavier sheets and plates. The two edges are melted down, and filler metal is added to fill up the corner.

Corner joints on heavy plates are welded from both sides, as shown in view D of figure 6-42. The joint is first welded from the outside, and then reinforced from the backside with a seal bead.

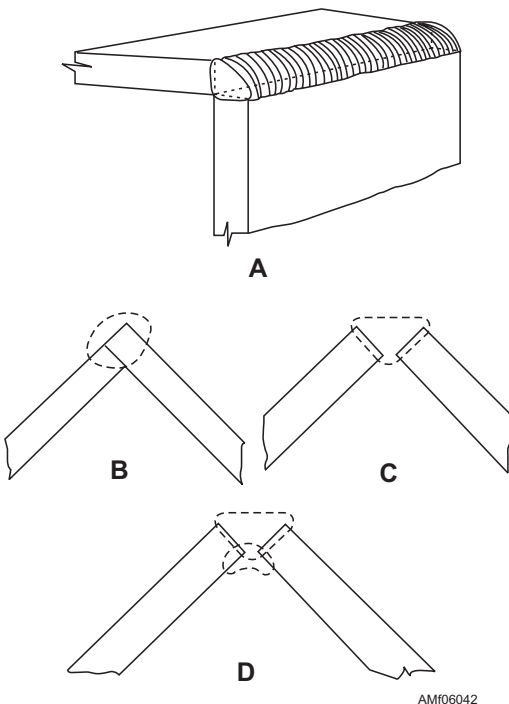

Figure 6-42.—Corner joints for sheets and plates.

Acetylene Safety Precautions

Acetylene safety precautions should be rigidly observed and enforced. Some of the more important precautions to remember are as follows:

1. Store acetylene cylinders in an upright position. They must be securely fastened to prevent shifting or falling. Do not place cylinders on sides, drop, or handle roughly. If horizontal stowage is necessary, or an acetylene cylinder is inadvertently left lying in a horizontal position, it must be placed in an upright position for a minimum of 2 hours before it can be used. (Otherwise, acetone in which the acetylene is dissolved will be drawn out with the gas.) Avoid damaging the valves or fuse plugs to prevent leakage.

2. Store acetylene cylinders in a well-protected, well-ventilated, dry place, away from heating devices or combustible materials.

3. Use acetylene from cylinders only through pressure-reducing regulators. Do not use acetylene at pressures greater than 15 psi.

4. Open the acetylene valve slowly, 1/4 to 1/2 turn. This will permit an adequate flow of gas. Never open the valve more than 1 1/2 turns of the spindle.

5. Keep sparks, flames, and heat away from acetylene cylinders.

6. Turn the acetylene cylinder so that the valve outlet will point away from the oxygen cylinder.

7. Do not interchange hose, regulators, or other apparatus intended for oxygen with those intended for acetylene.

8. Use only approved hoses and fittings with acetylene equipment. Pure copper, or copper alloys containing 67 to 99 percent copper, must not be used in piping or fittings for handling acetylene (except blowpipe or torch tips).

9. Test for leaks with soapy water—not with an open flame.

10. Make no attempt to transfer acetylene from one cylinder to another, refill an acetylene cylinder, or mix any other gas or gases with acetylene.

11. Keep valves closed on empty cylinders.

12. Should an acetylene cylinder catch fire, use a wet blanket to extinguish the fire. If this fails, spray a stream of water on the cylinder to keep it cool.

13. Crack each cylinder valve for an instant to blow dirt out of the nozzles before attaching the pressure

regulator. Do not stand in front of the valve when opening it.

14. Learn to identify standard Navy cylinders by color and decals.

GAS TUNGSTEN-ARC WELDING

Gas tungsten-arc (GTA) welding is an arc welding process that produces coalescence of metals by heating them with an electric arc between a nonconsumable tungsten electrode and the base metal. The weld pool, arc, electrode, and the heated section of the work pieces are protected from atmospheric contamination by a gaseous shield; otherwise, atmospheric oxygen and nitrogen will combine with the molten weld metal and result in a weak, porous weld. The shielding gas is usually an inert gas, such as helium, argon, or a mixture of gases.

The electrode used in GTA welding is generally tungsten or a tungsten alloy because other refractory metals would erode too rapidly at the high arc temperatures involved.

GTA welds are stronger, more ductile, and more corrosion-resistant than other types of arc welds. The weld zone has 100-percent protection from the atmosphere; therefore, no flux is required. Since no flux is required, it eliminates flux or slag inclusions in the weld, and there are no sparks, fumes, or spatter. With GTA welding, the welding heat, amount of penetration, and bead shape can be very accurately controlled, and the bead surface is smooth and uniform.

Welding Machines

Any standard dc or ac welding machine can be used to supply the current for gas tungsten-arc welding. However, it is important that the generator or transformer have good current control in the low range. This is necessary to maintain a stable arc, especially when welding thin gauge materials. Specially designed machines with all of the necessary controls are available for gas tungsten-arc welding. Many of the power supply units are made to produce both ac and dc current.

The choice of an ac or dc machine depends on what weld characteristics may be required. Some metals are joined more easily with ac current, while others get better results when dc current is used.

Welding Currents

With direct current the welding circuit may be either dc straight polarity (DCSP) or dc reverse polarity (DCRP). When the machine is set for straight polarity, the flow of electrons is from the electrode to the plate, which creates considerable heat in the plate. In reverse polarity, the flow of electrons is from the plate to the electrode, thus causing a greater concentration of heat at the electrode. See figure 6-43. The intense heat at the electrode tends to melt off the end of the electrode and may contaminate the weld. Hence, for any given current, dc reverse polarity requires a larger diameter electrode than dc straight polarity. For example, a 1/16-inch diameter tungsten electrode normally can handle about 125 amperes in a straight polarity circuit. However, if reverse polarity is used with this amount of current, the tip of the electrode will melt off. Consequently, a 1/4-inch diameter electrode will be required to handle 125 amperes of welding current.

Polarity also affects the shape of the weld. Straight polarity produces a narrow, deep weld, whereas reverse polarity with its larger diameter electrode and lower current forms a wide and shallow weld. Therefore, dc straight polarity is used for welding most metals because better welds are achieved. With the heat concentrated at the plate, the welding process is more rapid, and there is less distortion of the base metal.

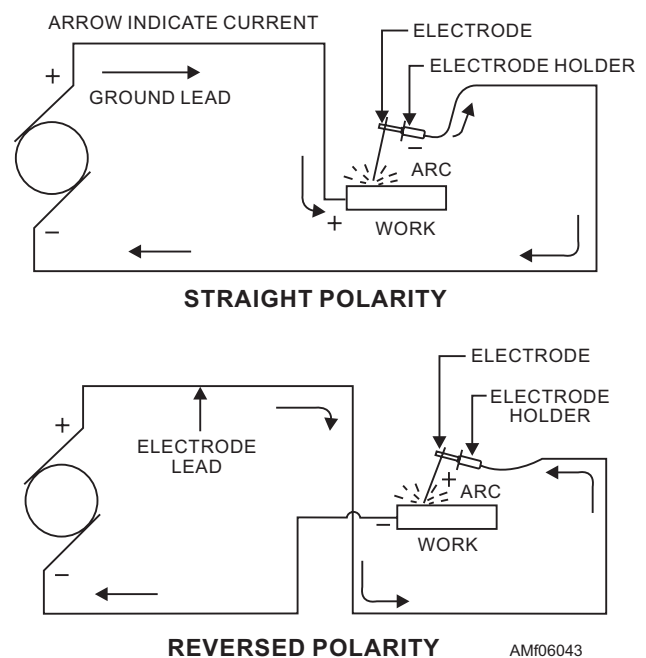

Figure 6-43.—Straight and reverse polarity in electric welding. AMf06043

Alternating current, high-frequency (ACHF) welding is a combination of dc straight polarity and dc reverse polarity. One half of the complete ac cycle is DCSP and the other half is DCRP. Unfortunately, oxides, scale, and moisture on the work piece often tend to prevent the full flow of current in the reverse polarity direction. If no current whatsoever flowed in the reverse polarity direction during a welding operation, the partial or complete stoppage of current flow would cause the arc to be unstable and sometimes go out. To prevent this, ac welding machines incorporate a high-frequency current flow unit. The high-frequency current is able to jump the gap between the electrode and the work piece, piercing the oxide film and forming a path for the welding current to flow.

Welding Equipment

Gas tungsten-arc welding equipment is produced by many manufacturers. For this reason, it is very important to remember that the equipment being discussed in this chapter is only one of the many types that can be found throughout the Navy. However, the functions of similar component parts of different makes of machines are identical, although they may not appear to be so.

TORCHES.—Manually operated torches are constructed to conduct both the welding current and the inert gas to the weld zone. These torches are either air or water-cooled. Air-cooled torches are designed for welding light gauge materials where low current values are used. Water-cooled torches (fig. 6-44) are recommended when the welding requires amperages over 200 amps. A circulating stream of water flows around the torch to keep it from overheating. The tungsten electrode, which supplies the welding current,

is held rigidly in the torch by means of a collet that screws into the body of the torch. A variety of collet sizes are available so different diameter electrodes can be used. Gas is fed to the weld zone through a nozzle, which consists of a ceramic cup. Gas cups are threaded into the torch head to provide directional and distributional control of the shielding gas. The cups are interchangeable to accommodate a variety of gas flow rates. Gas cups vary in size. The size you should use depends upon the type and size of torch and the diameter of the electrode.

Pressing a control switch on the torch starts the flow of both the current and gas. On some equipment, the flow of current and gas is energized by a foot control. The advantage of the foot control is that the variable current flow can be used as the end of the weld is reached. By gradually decreasing the current, it is less likely for a cavity to remain in the end of the weld puddle and less danger of cutting short the shielding gas.

ELECTRODES.—Pure tungsten, or tungsten alloyed with thorium or zirconium, is the best electrode for gas tungsten-arc welding. The addition of thorium increases the current capacity and electron emission, keeps the tip cooler at a given level of current, minimizes movement of the arc around the electrode tip, permits easier arc starting, and the electrode is not as easily contaminated by accidental contact with the work piece.

The diameter of the electrode selected for a welding operation is governed by the welding current to be used. Larger diameter tungsten electrodes are required with reversed polarity than with straight polarity.

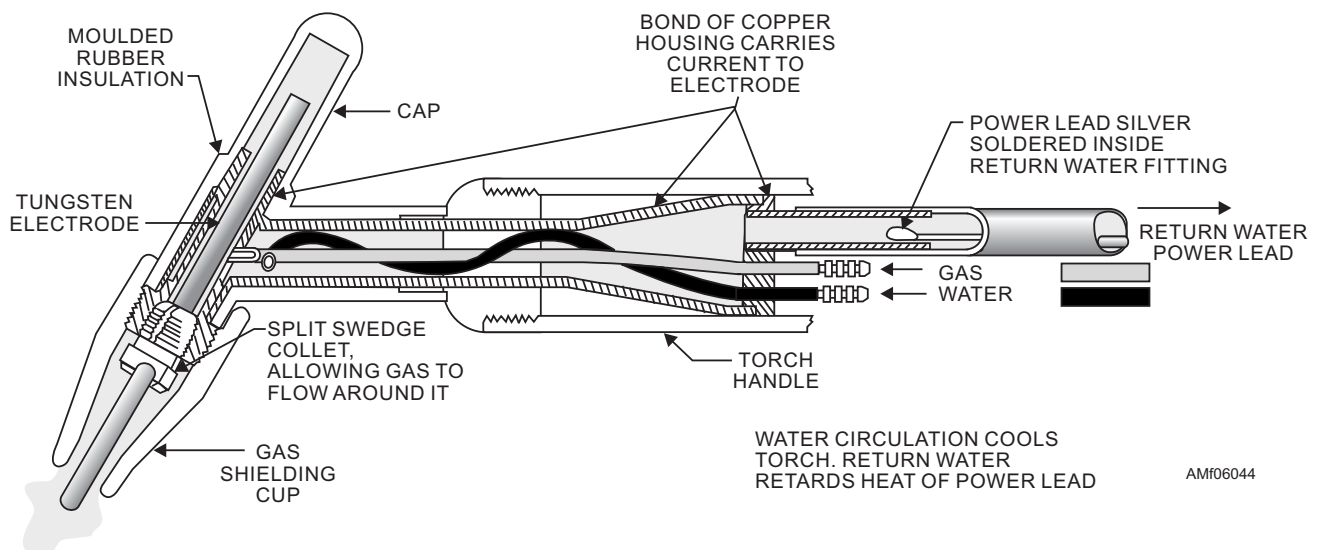

Figure 6-44.—Typical water-cooled GTA welding torch.

To produce good welds, the tungsten electrode must be shaped correctly. The general practice is to use a pointed electrode with dc welding, and a spherical end with ac welding. It is also important that the electrode be straight, otherwise the gas flow will be off-center from the arc.

SHIELDING GASES.—Shielding gas for gas tungsten-arc welding can be argon, helium, or a mixture of argon and helium. Argon is the most popular shielding gas used in the gas tungsten-arc process. Helium is rarely used because of its higher cost as compared to argon. In addition, since argon is heavier than air, it provides a better blanket over the weld. A mixture of argon and helium is sometimes used in welding metals that require a higher heat input.

Welding Procedures

Before you begin the welding process, be sure to observe the following preliminary steps:

1. Check all electrical circuit connections to make sure they are tight.
2. Check for proper diameter electrode and cup size.
3. Adjust the electrode so that it extends the appropriate distance beyond the edge of the gas cup for the particular joint being welded.
4. Check the electrode to be certain that it is firmly held in the collet. If the electrode moves in the nozzle, tighten the collet holder or gas cup. Be careful not to over tighten the gas cup because this will strip the threads.
5. Set the machine for the correct welding amperage.
6. If a water-cooled torch is to be used, turn on the water.
7. Turn on the inert gas and set it to the correct flow.

STARTING THE ARC.—If you are using an ac machine, the electrode should not touch the metal to start the arc. To strike the arc, first turn on the welding current and hold the torch in a horizontal position about 2 inches above the work. Angle the end of the torch toward the work piece so the end of the electrode is 1/8 inch above the plate. Figure 6-45 shows the procedure for starting the arc. The high-frequency current will jump the gap between the electrode and the plate, establishing the arc. Be sure the downward motion is

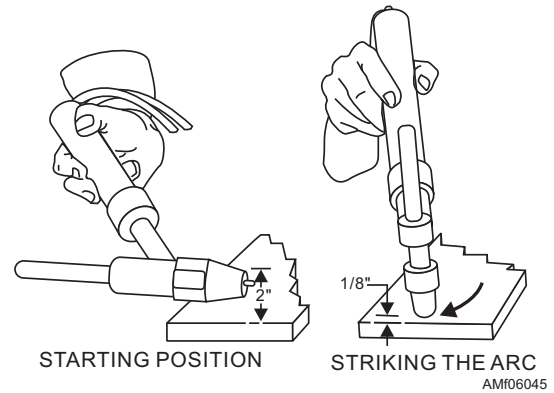

Figure 6-45.—Starting the arc.

made rapidly to provide the maximum amount of gas protection to the weld zone.

If a dc machine is used, hold the torch in the same position; but in this case, the electrode can touch the plate to start the arc. When the arc is struck, withdraw the electrode so it is about 1/8 inch above the work piece.

STOPPING THE ARC.—To stop an arc on the ac or dc machine, swing the electrode back to the horizontal position, as shown in figure 6-46. Make this movement rapidly to avoid marring or damaging the weld surface.

Some machines are equipped with a foot pedal to permit a gradual decrease of current. With such control, it is easier to fill the crater completely and prevent crater cracks.



Figure 6-46.—Breaking the arc.

CAUTION

If you are using a water-cooled cup, do not allow the cup to come in contact with the work when the current is on. The hot gases may cause the arc to jump the electrode to the cup instead of the plate, thereby damaging the cup. Be sure that the water flow is set according to the manufacturer's recommendations.

GAS METAL-ARC WELDING

Gas metal-arc (GMA) welding is a process that produces fusion by heating with an electric arc between a consumable wire electrode and the work. The arc and weld puddle are shielded from the atmosphere by a gas, or a gas and a flux. The shielding gas protects the molten weld metal from oxidation or contamination by the surrounding atmosphere.

The consumable-wire electrode for GMA welding is fed through the torch to the welding arc at the same rate as the heat of the arc melts off the end of the electrode. The shielding gas flows through the torch to the arc area. The melting rate of the filler wire depends on the level of the welding current, but must be the same as the feeding rate to maintain a constant arc length. This means that a constant balance must be maintained between the welding current and wire-feeding rate.

GMA Welding Equipment

There are numerous types and models of GMA welding equipment used in the Navy. Each must have a source of direct current reverse polarity (DCRP) welding current, a wire feed unit for feeding the wire filler metal, a welding gun for directing the wire filler and shielding gas to the weld area, and a gas supply. Figure 6-47 shows GMA welding equipment.

POWER SUPPLY.—The recommended machine for gas metal-arc welding is a rectifier or motor generator that supplies direct current with normal limits of 200 to 250 amperes. Direct current reverse polarity is most generally used because it provides maximum heat for better melting, deeper penetration, and excellent cleaning action.

Two types of direct-current power sources are used for gas metal-arc welding—the constant-current type and the constant-voltage type. The constant-current power source is used if the controls and wire-driven mechanism control the arc length by varying the wire-drive speed. In this case, a change in the arc length causes a change in the arc voltage. The control circuit senses this change and varies the wire-feed speed to bring the arc length back to the desired value.

When arc length is controlled through changes in welding current, constant-voltage power supplies are used. The wire-feed speed is constant. Any changes in

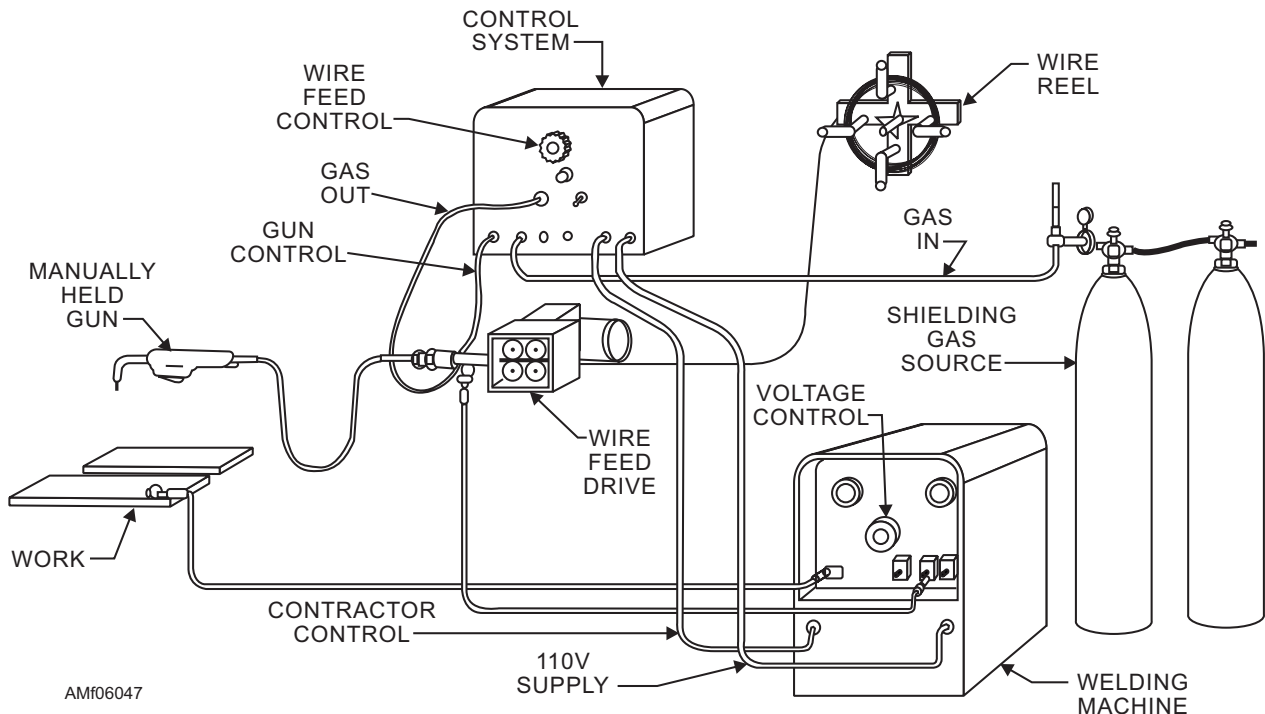

Figure 6-47.—GMA welding equipment.

arc length cause automatic changes in welding current, which compensate for the arc-length change. If the arc length becomes shorter, the welding current automatically increases. This causes the wire to melt faster and the arc length to increase. The reverse happens if the arc is lengthened during welding.

WIRE FEEDING MECHANISM.—The wire feeding mechanism automatically drives the electrode wire from the wire spool to the welding gun and arc at a uniform rate. The speed of the wire feeding mechanism is adjustable, so that the wire-feed speed can be set to equal the melting rate. If the drive unit is designed to be used with a constant-voltage power source, the speed is set before welding starts, and remains constant during welding. If the unit is to be used with a constant-current voltage power source, the drive unit speed is varied automatically by an electronic control device.

WELDING GUN.—The function of the welding gun is to deliver the wire, shielding gas, and welding current to the arc area. Guns are either the push or pull type. The pull gun has drive rolls that pull the welding wire from the wire feeder, and the push gun has the wire pushed to it by drive rolls in the wire feeder itself.

Both guns have a trigger switch that controls the wire feed and arc as well as the shielding gas. When the trigger is released, the wire feed, arc, and shielding gas stop immediately. With some equipment, a timer is included to permit the shielding gas to flow for a predetermined time to protect the weld until it solidifies.

Guns are available with a straight or curved nozzle. The curved nozzle provides easy access to intricate joints and difficult to weld patterns.

SHIELDING GAS.—Shielding gases in the gas metal-arc process are used primarily to protect the molten metal from oxidation and contamination. Other factors must be considered, however, in selecting the right gas for a particular application. Shielding gas can influence arc and metal transfer characteristics, weld penetration, width of fusion zone, surface-shape patterns, welding speed, and undercut tendency. Inert gases, such as argon and helium, provide the necessary shielding because they do not form compounds with any other substance and are insoluble in molten metal. When used for welding ferrous metals, arc action may be erratic and the metal transfer globular. Therefore, it is necessary to add controlled quantities of reactive gases to achieve good arc action and metal transfer with these materials.

Helium is preferable for welding thick materials, especially those with high heat conductivity, such as copper, aluminum, and some copper-base alloys. Helium has a higher ionization potential, which results in a greater weld heat at a given amperage. Argon is more suitable for use with lighter-gauge materials and materials of lower heat conductivity because it produces lower weld heat.

GMA Welding Techniques

Before you start to weld with GMA welding equipment, be sure that all controls are properly adjusted, all connections are correctly made, and that all safety precautions are being observed. Wear protective clothing, including a helmet with a suitable filter lens. Hold the welding torch at an angle of between 5° and 20° to the work, as shown in view B of figure 6-48. Support the weight of the welding cable

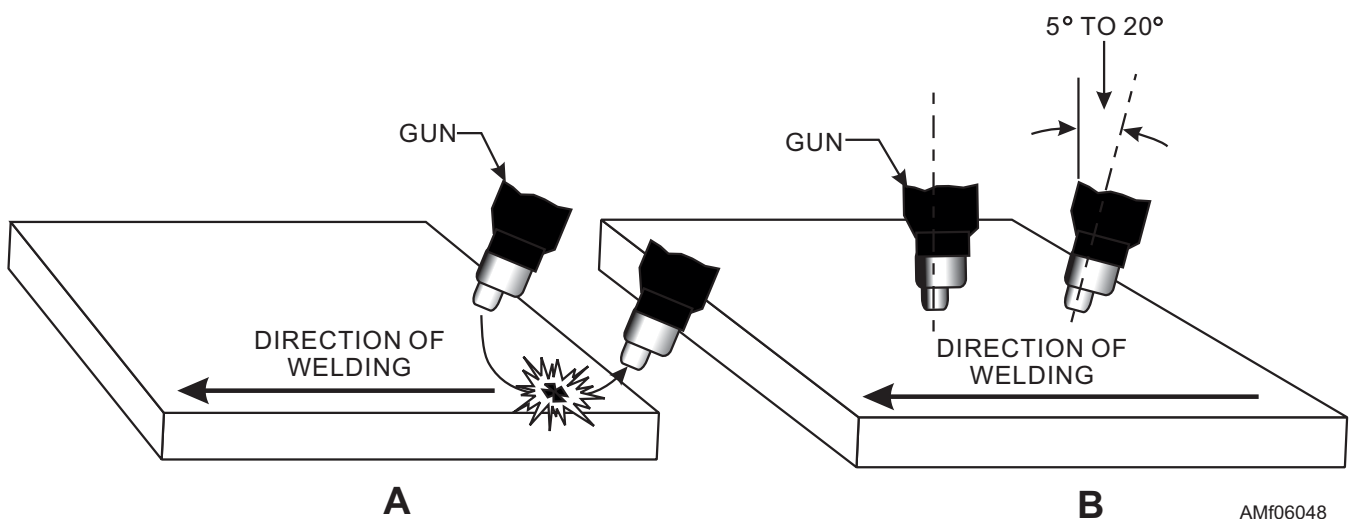

Figure 6-48.—Gas metal-arc welding. (A) striking the arc; (B) gun angle.

and gas hose across your shoulder to ensure free movement of the welding torch. Hold the torch close to, but not touching, the work piece. Lower your helmet and squeeze the trigger on the torch. Squeezing the trigger starts the flow of shielding gas and energizes the welding circuit. The wire-feed motor is not energized until the wire electrode comes in contact with the work piece. Move the torch toward the work, touching the wire electrode to the work with a sideways scratching motion, as shown in view A of figure 6-48. To prevent sticking, it is necessary to pull the gun back quickly, about 1/2 inch, the instant contact is made between the wire electrode and the work piece. The arc will strike as soon as contact is made, and the wire-feed motor will feed the wire automatically as long as the trigger is held.

To break the arc, just release the trigger. This breaks the welding circuit and also de-energizes the wire-feed motor. If the wire electrode sticks to the work when it strikes the arc, or at any time during welding, release the trigger and clip the wire with a pair of pliers or side cutters.

A properly established arc has a soft, sizzling sound. The arc itself is about 1/4 inch long, or about one-half the distance between the gun nozzle and the work. When the arc does not sound right, you may need to adjust the wire-feed control dial or the welding machine itself. For example, a loud, crackling sound indicates that the arc is too short and the wire-feed speed is too fast. Correct this by moving the wire-feed speed dial slightly counterclockwise. This decreases wire-feed speed and increases arc length. A clockwise movement of the dial has the opposite effect. With experience, you will soon be able to recognize the sound of the proper length of arc to use.

The proper position of the welding torch and material is important. The flat position of the material is preferred for most joints because this position improves the molten metal flow, bead contour, and gives better gas protection.

The alignment of the welding wire in relation to the joint is very important. The welding wire should be on the center line of the joint if the pieces to be joined are of equal thickness. If the pieces are unequal in thickness, the wire may be moved toward the thicker piece.

Correct work and travel angles are necessary for correct bead formations. The travel angle may be a push angle or a drag angle, depending upon the position of the gun. If the gun is angled back toward the beginning

of the weld, the travel angle is called a "drag" angle. If the gun is pointed ahead toward the end of the weld, the travel angle is called a "push" angle.

When the gun is ahead of the weld, it is referred to as pulling the weld metal. If the gun is behind the weld, it is referred to as pushing the metal. The pulling technique is usually best for light gauge metals and the pushing technique for heavy materials.

Generally, the penetration of beads deposited with the pulling technique is greater than with the pushing technique. Furthermore, since the welder can see the weld crater easier in a pulling action, he/she can produce high quality welds more consistently. On the other hand, pushing permits the use of higher welding speeds and produces less penetrating and wider welds.

WELDING SAFETY PRECAUTIONS

Accidents frequently occur in welding operations, and in many instances, they result in serious injury to the welder or other personnel working in the immediate area. What many welders fail to realize is that accidents often occur NOT because of a lack of protective equipment, but because of carelessness, lack of knowledge, and the misuse of available equipment.

You, the welder, should have a thorough KNOWLEDGE of safety precautions relating to the job. But that is not all. You should also consider it a responsibility to carefully OBSERVE the applicable safety precautions. In welding, being careless can cause serious injury not only to yourself, but to others as well.

Bear in mind that safety precautions for the operation of welding equipment vary considerably because of the different types of equipment involved. Therefore, only general precautions on operating metal arc-welding equipment are given here. For specific instructions on the operation, maintenance, and care of individual equipment, use the equipment manufacturer's instruction manual as a guide.

In regard to general precautions, know your equipment and how to operate it. Use only approved welding equipment, and see that it is kept in good, clean condition. Before you start to work, make sure that the welding machine frame is grounded, that neither terminal of the welding generator is bonded to the frame, and that all electrical connections are securely made. The ground connection must be attached firmly to the work, not merely laid loosely upon it.

Keep welding cables dry and free of oil or grease. Keep cables in good condition, and, at all times, take

appropriate steps to protect them from damage. If it is necessary to carry cables some distance from the machines, run the cables overhead, if possible, and use adequate supporting devices.

When you use a portable machine, take care to see that the primary supply cable is laid separately so that it does not become entangled with the welding supply cable. Any portable equipment mounted on wheels should be securely blocked to prevent accidental movement during the welding operations.

When you stop work for any appreciable length of time, be SURE to de-energize the equipment. When not in use, the equipment should be completely disconnected from the source of power.

Keep the work area neat and clean. Among other things, make it a practice to dispose of hot electrode stubs in a metal container.

Proper eye protection is of the utmost importance, not only to the welding operator, but for other personnel in the vicinity of the welding operation. Eye protection is necessary because of the hazards posed by stray flashes, reflected glare, flying sparks, and globules of molten metal.

- Q6-33. *Welding training and testing are conducted at what facilities?*
- Q6-34. *What is the recertification interval for IMA-level aeronautical equipment welders if proficiency is maintained?*
- Q6-35. *If you fail the first test weld(s), what amount of time do you have to submit the retest welds after notification of failure?*
- Q6-36. *What are the two main purposes of the welding torch?*
- Q6-37. *What is the temperature range of acetylene when mixed with oxygen?*
- Q6-38. *What are the three main characteristics of oxygen?*
- Q6-39. *If an oxygen bottle has a white band around it, what type of oxygen does it contain?*
- Q6-40. *What pressure does the low pressure (0 to 500 psi) gauge on a single-stage regulator indicate?*
- Q6-41. *Acetylene is colorless, but has what feature that makes it easily detected?*
- Q6-42. *At what pressure does acetylene become self-explosive?*

- Q6-43. *What is another name for a low-pressure welding torch?*
- Q6-44. *What color is the acetylene hose on an oxyacetylene welding system?*
- Q6-45. *The thread fittings for the oxygen hose hookup of an oxyacetylene welding system always have what type of threads?*
- Q6-46. *Regardless of the shade of your welding goggle's lens, they should be protected by what type of material?*
- Q6-47. *Bronze and aluminum welding rods are examples of what type of welding rods?*
- Q6-48. *What type of flame has three distinct zones and is used to weld nickel alloys?*
- Q6-49. *What type of flame has a small, white pointed cone in the inner zone with a purple tinge and is used to fuse brass and bronze?*
- Q6-50. *An overheated welding tip, accompanied by a popping sound, indicates what action has occurred?*
- Q6-51. *Define the term "flashback" as it applies to a welding torch.*
- Q6-52. *When the torch is held properly, the tip should be in line with what structure?*
- Q6-53. *What welding technique is the best method for welding lighter metals?*
- Q6-54. *Tee and lap joints are classified as what type of welds?*
- Q6-55. *Corner and butt joints are classified as what type of welds?*
- Q6-56. *What type of joint is formed when two pieces of metal are placed edge-to-edge with no overlap and welded together?*
- Q6-57. *What type of joint is formed when two pieces of metal are welded approximately perpendicular to each other?*
- Q6-58. *What type of joint is formed by welding two overlapping metals together?*
- Q6-59. *What type of joint is formed when two or more parallel or nearly parallel pieces of metal are welded together?*
- Q6-60. *What type of electrode is used in GTA welding because of its ability to resist high temperatures?*

- Q6-61. *DC reverse polarity in a welding machine causes a greater concentration of heat in what location?*
- Q6-62. *Directional and distributional control of the shielding gas is provided by what component?*
- Q6-63. *What is the most common type of shielding gas used in the tungsten-arc welding process?*
- Q6-64. *When striking an arc, you should hold the electrode what distance above the work piece?*
- Q6-65. *The process that uses a consumable wire electrode is known as what type of welding?*
- Q6-66. *What determines the melting rate of the filler wire?*
- Q6-67. *When you use the GMA welding method to weld aluminum, what is the preferred shielding gas?*
- Q6-68. *When you use the GMA welding method, why should you pull the gun back quickly when contact is made between the electrode and the work piece?*
- Q6-69. *If you hear a loud crackling sound while you are GMA welding, what direction should you move the wire-feed speed dial to correct this?*
- Q6-70. *When using GMA welding equipment, where should you attach the ground connection?*
- Q6-71. *When GMA welding equipment is not in use, what should you do to the power source?*

HEAT TREATMENT OF METALS

LEARNING OBJECTIVE: Recognize the principles of heat treatment. Identify the most common forms of heat treatment.

This text covers the forms and principles of heat treatment in general. Ferrous and nonferrous heat treatment of metals is covered. Covered information is for training purposes only. When actually performing heat treatment tasks, you must refer to the applicable technical publications.

Heat treatment is a series of operations involving the heating and cooling of a metal or alloy in the solid state for the purpose of obtaining certain desirable characteristics. The rate of heating and cooling determines the crystalline structure of the material. In general, both ferrous metals (metals with iron bases)

and nonferrous metals, as well as their alloys, respond to some form of heat treatment. Almost all metals have a critical temperature at which the grain structure changes. Successful heat treatment, therefore, depends largely on knowledge of these temperatures as well as the time required to produce the desired change.

PRINCIPLES OF HEAT TREATMENT

The results that may be obtained by heat treatment depend, to a great extent, on the structure of the metal and the manner in which the structure changes when the metal is heated and cooled. A pure metal cannot be hardened by heat treatment because there is little change in its structure when heated. On the other hand, most alloys respond to heat treatment because their structures change with heating and cooling.

An alloy may be in the form of a solid solution, mechanical mixture, or a combination of a solid solution and a mechanical mixture. When an alloy is in the form of a solid solution, the elements and compounds that form the alloy are absorbed, one into the other, in much the same way that salt is dissolved in a glass of water. The constituents cannot be identified even under a microscope.

When two or more elements or compounds are mixed, but can be identified by microscopic examination, a mechanical mixture is formed. A mechanical mixture might be compared to the mixture of sand and gravel in concrete. The sand and gravel are both visible. Just as the sand and gravel are held together and kept in place by the mixture of cement, the other constituents of an alloy are embedded in the mixture formed by the base metal.

An alloy that is in the form of a mechanical mixture at ordinary temperatures may change to a solid solution when heated. When cooled back to normal temperature, the alloy may return to its original structure. On the other hand, it may remain a solid solution or form a combination of a solid solution and mechanical mixture. An alloy that consists of a combination of a solid solution and mechanical mixture at normal temperatures may change to a solid solution when heated. When cooled, the alloy may remain a solid solution, return to its original structure, or form a complex solution.

Heat treatment involves a cycle of events. These events are heating, generally done slowly to ensure uniformity; soaking, or holding the metal at a given temperature for a specified length of time; and cooling,

or returning the metal to room temperature, sometimes rapidly, sometimes slowly.

Heating

Uniform temperature is of primary importance in the heating cycle. If one section of a part is heated more rapidly than another, the resulting uneven expansion often causes distortion or cracking of the part. Uniform heating is obtained by slow heating.

The rate at which a part may be heated depends on several factors. One important factor is the heat conductivity of the metal. A metal that conducts heat readily may be heated at a faster rate than one in which heat is not absorbed throughout the part as rapidly. The condition of the metal also affects the rate at which it may be heated. For example, the heating rate for hardened tools and parts should be slower than for metals that are not in a stressed condition. Finally, size and cross section have an important influence on the rate of heating. Parts large in cross section require a slower heating rate than thin sections. This slower heating rate is necessary so that the interior will be heated to the same temperature as the surface. It is difficult to uniformly heat parts that are uneven in cross section, even though the heating rate is slow. However, such parts are less apt to be cracked or excessively warped when the heating rate is slow.

Soaking

The object of heat-treating is to bring about changes in the properties of metal. To accomplish this, the metal must be heated to the temperature at which structural changes take place within the metal. These changes occur when the constituents of the metal go into the solution. Once the metal is heated to the proper temperature, it must be held at that temperature until the metal is heated throughout and the changes have time to take place. This holding of the metal at the proper temperature is called **SOAKING**. The length of time at that temperature is called the **SOAKING PERIOD**. The soaking period depends on the chemical analysis of the metal and the mass of the part. When steel parts are uneven in cross section, the soaking period is determined by the heaviest section.

In heating steels, the metal is seldom raised from room temperature to the final temperature in one operation. Instead, the steel is slowly heated to a temperature below the point at which the solid solution begins, and it is then held at that temperature until heat is absorbed throughout the metal. This process is called

PREHEATING. Following the preheating, the steel is quickly heated to the final temperature. Preheating aids in obtaining uniform temperature throughout the part being heated, and, in this way, reduces distortion and cracking. When a part is of intricate design, it may have to be preheated at more than one temperature to prevent cracking and excessive warping. As an example, assume that an intricate part is to be heated to 1,500°F (815°C) for hardening. This part might be slowly heated to 600°F (315°C), be soaked at this temperature, then be heated slowly to 1,200°F (649°C), and then be soaked at that temperature. Following the second preheat, the part would be heated quickly to the hardening temperature. Nonferrous metals are seldom preheated because they usually do not require it. Furthermore, preheating tends to increase the grain size in these metals.

Cooling

After being heated to the proper temperature, the metal must be returned to room temperature to complete the heat-treating process. The metal is cooled by placing it in direct contact with a gas, liquid, or solid, or some combination of these. The solid, liquid, or gas used to cool the metal is called a "cooling medium." The rate at which the metal should be cooled depends on both the metal and the properties desired. The rate of cooling also depends on the medium; therefore, the choice of a cooling medium has an important influence on the properties obtained.

Cooling metals rapidly is called "quenching," and the oil, water, brine, or other mediums used for rapid cooling is called a "quenching medium." Since most metals must be cooled rapidly during the hardening process, quenching is generally associated with hardening. However, quenching does not always result in an increase in hardness. For example, copper is usually quenched in water during annealing. Other metals, air-hardened steels for example, may be cooled at a relatively slow rate for hardening.

Some metals are easily cracked or warped during quenching. Other metals may be cooled at a rapid rate with no ill effects. Therefore, the quenching medium must be chosen to fit the metal. Brine and water cool metals quickly, and should be used only for metals that require a rapid rate of cooling. Oil cools at a slower rate and is more suitable for metals that are easily damaged by rapid cooling. Generally, carbon steels are considered water hardened and alloy steels oil hardened. Nonferrous metals are usually quenched in water.

FORMS OF HEAT TREATMENT

The various heat-treating processes are similar in that they involve the heating and cooling of metals. They differ, however, in the temperatures to which the metals are heated, the rates at which they are cooled, and, of course, in the final result. The most common forms of heat treatment for ferrous metals are annealing, normalizing, hardening, tempering, and case hardening. Most nonferrous metals can be annealed but never tempered, normalized, or case hardened. Successful heat-treating requires close control over all factors affecting the heating and cooling of metals. Such control is possible only when the proper equipment is available, and the equipment is selected to fit the particular job.

Annealing

Annealing is used to reduce residual stresses, induce softness, alter ductility, or refine the grain structure. Maximum softness in metal is accomplished by heating it to a point above the critical temperature, holding at this temperature until the grain structure has been refined, followed by slow cooling.

Normalizing

Normalizing is a process whereby iron base alloys are heated to approximately 100°F (56°C) above the upper critical temperature, followed by cooling to room temperature in still air. Normalizing is used to establish materials of the same nature with respect to grain size, composition, structure, and stress.

Hardening

Hardening is accomplished by heating the metal slightly in excess of the critical temperature, and then rapidly cooling by quenching in oil, water, or brine. This treatment produces a fine grain structure, extreme hardness, maximum tensile strength, and minimum ductility. Generally, material in this condition is too brittle for most practical uses, although this treatment is the first step in the production of high-strength steel.

Tempering

Tempering (drawing) is a process generally applied to steel to relieve the strains induced during the hardening process. It consists of heating the hardened

steel to a temperature below the critical range, holding this temperature for a sufficient period, and then cooling in water, oil, or air. In this process, the degrees of strength hardness and ductility obtained depend directly upon the temperature to which the steel is heated. High tempering temperatures improve ductility at the sacrifice of tensile, yield strength, and hardness.

Case Hardening

The objective in case hardening is to produce a hard case over a tough core. Case hardening is ideal for parts that require a wear-resistant surface and, at the same time, must be tough enough internally to withstand the applied loads. The steels best suited to case hardening are the low-carbon and low-alloy steels. If high-carbon steel is case-hardened, the hardness penetrates the core and causes brittleness. In case hardening, the surface of the metal is changed chemically by inducing a high carbide or nitride content. The core is unaffected chemically. When heat-treated, the surface responds to hardening while the core toughens. The common methods of case hardening are carburizing, nitriding, and cyaniding.

CARBURIZING.—Carburizing consists of holding the metal at an elevated temperature while it is in contact with a solid or gaseous material rich in carbon. The process requires several hours, as time must be allowed for the surface metal to absorb enough carbon to become high-carbon steel. The material is then quenched and tempered to the desired hardness.

NITRIDING.—Nitriding consists of holding special alloy steel, at temperatures below the critical point, in anhydrous ammonia. Absorption of nitrogen as iron nitride into the surface of the steel produces a greater hardness than carburizing, but the hardened area extends to a lesser depth.

CYANIDING.—Cyaniding is a rapid method of producing surface hardness on an iron base alloy of low-carbon content. It may be accomplished by immersion of the steel in a molten bath of cyanide salt, or by applying powdered cyanide to the surface of the heated steel. The temperature of the steel during this process should range from 760° to 899°C (1,400° to 1,650°F), depending upon the type of steel, depth of case desired, type of cyanide compound, and time exposed to the cyanide. The material is dumped directly from the cyanide pot into the quenching bath.

HEAT TREATMENT OF FERROUS METALS (STEEL)

The first important consideration in the heat treatment of a steel part is to know its chemical composition. This, in turn, determines its upper critical point. When the upper critical point is known, the next consideration is the rate of heating and cooling to be used. Uniform-heating furnaces, proper temperature controls, and suitable quenching mediums are used in carrying out these operations.

Principles of Heat Treatment of Steel

Changing the internal structure of a ferrous metal is accomplished by heating it to a temperature above its upper critical point, holding it at that temperature for a time sufficient to permit certain internal changes to occur, and then cooling to atmospheric temperature under predetermined, controlled conditions.

At ordinary temperatures, the carbon in steel exists in the form of particles of iron carbide scattered throughout the iron mixture known as **ferrite**. The number, size, and distribution of these particles determine the hardness of the steel. At elevated temperatures, the carbon is dissolved in the mixture in the form of a solid solution called "austenite," and the carbide particles appear only after the steel has been cooled. If the cooling is slow, the carbide particles are relatively coarse and few. In this condition the steel is soft. If cooling is rapid, as by quenching in oil or water, the carbon precipitates as a cloud of very fine carbide particles, and the steel is hardened. The fact that the carbide particles can be dissolved in austenite is the basis of the heat treatment of steel. The temperatures at which this transformation takes place are called the "critical points," and vary with the composition of the steel. The element normally having the greatest influence is carbon. The various heat-treating procedures for commonly used aircraft steels are outlined in *Aerospace Metals—General Data and Usage Factors*, NAVAIR 01-1A-9.

Forms of Heat Treatment of Steel

There are different forms of heating ferrous materials such as steel. The methods covered in this chapter are hardening, quenching, tempering, annealing and normalizing, and case hardening. Terms such as *carburizing*, *cyaniding*, and *nitriding* are also discussed.

HARDENING.—Heat treatment considerably transforms the grain structure of steel, and it is while passing through a critical temperature range that steel acquires hardening power. When a piece of steel is heated slowly and uniformly beyond a red heat, its appearance will increase in brightness until a certain temperature is reached. The color will change slightly, becoming somewhat darker, which may be taken as an indication that a transformation is taking place within the metal (pearlite being converted into austenite). When this change of state is complete, the steel will continue to increase in brightness, and if cooled quickly to prevent the change from reversing, hardness will be produced. If, instead of being rapidly quenched, the steel is allowed to cool slowly, the metal will again pass through a change of state, and the cooling rate will be momentarily arrested.

To obtain a condition of maximum hardness, it is necessary to raise the temperature of the steel sufficiently high to cause the change of state to fully complete itself. This temperature is known as the **upper critical point**. Steel that has been heated to its upper critical point will harden completely if rapidly quenched; however, in practice, it is necessary to exceed this temperature by approximately 28° to 56°C (50° to 100°F) to ensure thorough heating of the inside of the piece. If the upper critical temperature is exceeded too much, an unsatisfactory coarse grain size will be developed in the hardened steel.

Successful hardening of steel will largely depend upon the following factors:

1. Control over the rate of heating, specifically to prevent cracking of thick and irregular sections
2. Thorough and uniform heating through sections to correct hardening temperatures
3. Control of furnace atmosphere, in the case of certain steel parts, to prevent scaling and decarburization
4. Correct heat capacity, viscosity, and temperature of quenching media, to harden adequately and to avoid cracks

When heating steel, you should use accurate instruments to determine the temperature. At times, however, such instruments are not available, and in such cases, the temperature of the steel may be judged approximately by its color. The temperatures

corresponding to various colors are given in table 6-1; however, the accuracy with which temperatures may be judged by colors depends on the experience of the worker and on the light in which the work is being done.

QUENCHING PROCEDURE.—A number of liquids may be used for quenching steel. Both the media and the form of the bath depend largely on the nature of the work to be cooled. It is important that a sufficient quantity of the media be provided to allow the metal to be quenched without causing an appreciable change in the temperature of the bath. This is particularly important where many articles are to be quenched in succession.

The tendency of steel to warp and crack during the quenching process is difficult to overcome because certain parts of the article cool more rapidly than others. Whenever the transformation of temperature is not uniform, internal strains are set up in the metal that result in warping or cracking, depending on the severity of the strains. Irregularly shaped parts are particularly susceptible to these conditions, although parts of an even section are often affected in a similar manner. Operations such as forging and machining may set up internal strains in steel parts; therefore, it is advisable to normalize articles before attempting the hardening process. The following recommendations will greatly reduce the warping tendency and should be carefully observed:

1. An article should never be thrown into the bath. By permitting it to lie on the bottom of the bath, it is apt to cool faster on the top side than on the bottom side, thus causing it to warp or crack.

2. The article should be slightly agitated in the bath to destroy the coating of vapor, which might prevent it from cooling rapidly.

3. An article should be quenched in such a manner that all parts will be cooled uniformly and with the least possible distortion.

4. Irregularly shaped sections should be immersed in such a manner that the area with the biggest section enters the bath first.

Quenching Media.—In certain cases water is used in the quenching of steel during the hardening process. The water bath temperature is normally held at 18°C (65°F). For specific applications, other bath temperatures may be used; however, cold water may warp or crack the part, and hot water may not produce the required hardness.

A 10-percent salt brine solution is used when higher cooling rates are desired. A 10-percent salt brine solution is made by dissolving .89 pounds of salt per gallon of water.

Oil is much slower in action than water, and the tendency of heated steel to warp or crack when

Table 6-1.—Color Chart for Steel at Various Temperatures

COLOR	METAL TEMPERATURE	
	Degrees C	Degrees F
Faint red	482	900
Blood red	566	1,050
Dark cherry	579.5	1,075
Medium cherry	677	1,250
Cherry or full red	746	1,375
Bright red	843	1,550
Salmon	899	1,650
Orange	940.5	1,725
Lemon	996	1,825
Light lemon	1,079.5	1,975
White	1,204	2,200
Dazzling white	1,288	2,350

quenched may be greatly reduced by its use. Unfortunately, parts made from high-carbon steel will not develop maximum hardness when quenched in oil unless they are quite thin in cross section. In aircraft parts, however, it is generally used, and is recommended in all cases where it will produce the desired degree of hardness.

For many articles, a bath of water covered by a film of oil is occasionally used. When the steel is plunged through this oil film, a thin coating will adhere to it. This action retards the cooling of the water slightly, thus reducing the tendency to crack due to contraction.

Straightening of Parts Warped in Quenching.—Warped parts must be straightened by first heating to below the tempering temperature of the article, and then applying pressure. This pressure should be continued until the piece is cooled. It is desirable to retemper the part after straightening at the straightening temperature. No attempt should be made to straighten hardened steel without heating, regardless of the number of times it has been previously heated. Steel in its hardened condition cannot be bent or sprung cold with any degree of safety.

TEMPERING.—Steel that has been hardened by rapid cooling from a point slightly above its critical range is often harder than necessary, and generally too brittle for most purposes. In addition, it is under severe internal strain. To relieve the strains and reduce brittleness, the metal is usually **tempered**. This is accomplished in the same types of furnaces that are used for hardening and annealing.

As in the case of hardening, tempering temperatures may be approximately determined by color. These colors appear only on the surface and are due to a thin film of oxide, which forms on the metal after the temperature reaches 220°C (428°F). To see the tempering colors, you must brighten the surface. When tempering by the color method, an open flame or heated iron plate is ordinarily used as the heating medium. Although the color method is convenient, it should not be used unless adequate facilities for determining temperatures are not obtainable. The temperatures and corresponding oxide colors are given in table 6-2.

ANNEALING AND NORMALIZING.—When steel is heated to a point above its critical range, a condition referred to as "austenite" is produced. If slowly cooled from above its critical temperature, the austenite is broken down and a succession of other conditions are produced, each being normal for a particular range of temperatures. Starting with austenite, these successive conditions are **martensite**, **troostite**, **sorbite**, and finally **pearlite**.

The most important step in annealing is to raise the temperature of the metal to the critical point, as any hardness that may have existed will then be completely removed. Strains that may have been set up through heat treatment will be eliminated when the steel is heated to the critical point, and then restored to its lowest hardness by slow cooling. In annealing, the steel must never be heated more than approximately 28° to 40°C (50° to 75°F) above the critical point. When large articles are annealed, sufficient time must be allowed for the heat to penetrate the metal.

Table 6-2.—Color Chart for Various Tempering Temperatures of Carbon Steel

OXIDE COLOR	METAL TEMPERATURE	
	Degrees C	Degrees F
Pale yellow	220	428
Straw	230	446
Golden yellow	243	469
Brown	254	491
Brown dappled with purple	266	509
Purple	277	531
Dark blue	288	550
Bright blue	297	567
Pale blue	321	610

Steel is usually subjected to the annealing process for the following purposes:

1. To increase its ductility by reducing hardness and brittleness.

2. To refine the crystalline structure and remove residual stresses. Steel that has been cold worked is usually annealed to increase its ductility.

Assuming that the part to be annealed is heated to the proper temperature, the required slow cooling may be accomplished in several ways, depending on the metal and the degree of softness required.

Normalizing, although involving a slightly different heat treatment, may be classed as a form of annealing. This process removes all strains due to machining, forging, bending, and welding. Normalizing can only be accomplished with a good furnace, where the temperatures and the atmosphere may be closely regulated and held constant throughout the entire operation. A reducing atmosphere will normalize the metal with a minimum amount of oxide scale, while an oxidizing atmosphere will leave the metal heavily coated with scale, thus preventing proper development of hardness in any subsequent hardening operation. The articles are put in the furnace and heated to a point above the critical temperature of the steel. After the parts have been held at this temperature for a sufficient time to allow the heat to penetrate to the center of the section, they must be removed from the furnace and cooled in still air. Drafts will result in uneven cooling, which will again set up strains in the metal.

Prolonged soaking of the metal at high temperatures must be avoided, as this practice will cause the grain structure to enlarge. The length of time required for the soaking temperature will depend upon the mass of metal being treated.

CASE HARDENING.—In many instances, it is desirable to produce a hard, wear-resistant surface or "case" over a strong, tough core. Treatment of this kind is known as "case hardening." This treatment may be accomplished in several ways; the principal ways being carburizing, cyaniding, and nitriding.

Carburizing.—When steel is heated, the pores of the metal expand, allowing it to absorb any gases to which it is exposed. By heating steel while it is in contact with a carbonaceous substance, carbonic gases given off by this material will penetrate the steel to an amount proportional to the time and temperature.

The carburizing process may be applied to plain carbon steels provided they are within the low-carbon

range. Specifically, the carburizing steels are those that contain no more than 0.20 percent carbon. The lower the carbon content in the steel, the more readily it will absorb carbon during the carburizing process.

The amount of carbon absorbed and the thickness of the case obtained increase with time; however, the carburization progresses more slowly as the carbon content increases during the process. The length of time required to produce the desired degree of carburization and depth of the case depend upon the composition of the metal, the kind of carburization material used, and the temperature to which the metal is subjected. It is apparent that in carburizing, carbon travels slowly from the outside toward the center; therefore, the proportion of carbon absorbed must decrease from the outside to the center.

A common method of carburizing is called "pack carburizing." When carburizing is to be done by this method, the steel parts are packed with the carburizing material in a sealed steel container to prevent the solid carburizing compound from burning and retaining the carbon monoxide and dioxide gases. The container should be placed in a position to allow the heat to circulate entirely around it. The furnace must be brought to the carburizing temperature as quickly as possible, and held at this heat from 1 to 16 hours, depending upon the depth of the case desired and the size of the work. After carburizing, the container should be removed and allowed to cool in the air, or the parts removed from the carburizing compound and quenched in oil or water. The air-cooling, although slow, reduces warpage, and is advisable in many cases.

In another method of carburizing, called "gaseous carburizing," a carbonaceous material is introduced into the furnace atmosphere. When the steel parts are heated in this carburizing atmosphere, carbon monoxide combines with the iron to produce results that are practically the same as those described under the pack carburizing process.

Cyaniding.—Steel parts may be surface hardened by heating while in contact with a cyanide salt, followed by quenching. Only a thin case is obtained by this method; therefore, it is seldom used in connection with aircraft construction or repair. However, cyaniding is a rapid and economical method of case hardening, and may be used in some instances for relatively unimportant parts. The work to be hardened is immersed in a bath of molten sodium or potassium cyanide from 30 to 60 minutes. The cyanide bath should be maintained at a temperature of 760° to 899°C (1,400° to 1,650°F). Immediately after removal from

the bath, the parts are quenched in water. The case obtained in this manner is due principally to the formation of carbides on the surface of the steel. The use of a closed pot is required for cyaniding, as cyanide vapors are extremely poisonous.

Nitriding.—This method of case hardening is advantageous because a harder case is obtained than by carburizing. Nitriding can only be applied to certain special steel alloys, one of the essential constituents of which is aluminum. The process involves the soaking of the parts in the presence of anhydrous ammonia at a temperature below the critical point of the steel. During the soaking period, the aluminum and iron combine with the nitrogen of the ammonia to produce iron nitrides in the surface of the metal. Warpage of work during nitriding can be reduced by stress-relief annealing, and by exposure to nitrogen at temperatures no higher than 538°C (1,000°F). Growth of the work is similarly prevented, but cannot be entirely eliminated, and some parts may require special allowance in some dimensions to take care of growth.

The temperature required for nitriding is 510°C (950°F), and the soaking period from 48 to 72 hours. An airtight container must be used, and it should be provided with a fan to produce good circulation and even temperature throughout. No quenching is required, and the parts may be allowed to cool in air.

HEAT TREATMENT OF NONFERROUS METALS (ALUMINUM ALLOYS)

Aluminum is a white, lustrous metal, light in weight and corrosion resistant in its pure state. It is ductile, malleable, and nonmagnetic. Aluminum combined with various percentages of other metals, generally copper, manganese, and magnesium, form the aluminum alloys that are used in aircraft construction. Aluminum alloys are lightweight and strong, but do not possess the corrosion resistance of pure aluminum and are generally treated to prevent deterioration. "**Alclad**" is an aluminum alloy with a protective coating of aluminum to make it almost equal to the pure metal in corrosion resistance.

Several of the aluminum alloys respond readily to heat treatment. In general, this treatment consists of heating the alloy to a known temperature, holding this temperature for a definite time, then quenching the part to room temperature or below. During the heating process, a greater number of the constituents of the metal are put into solid solution. Rapid quenching

retains this condition, which results in a considerable improvement in the strength characteristics.

The heating of aluminum alloy should be done in an electric furnace or molten salt bath. The salt bath generally used is a mixture of equal parts of potassium nitrate and sodium nitrate. Parts heated by this method must be thoroughly washed in water after treatment. The salt bath method of heating should never be used for complicated parts and assemblies that cannot be easily washed free of the salt.

Heat Treating Procedures

There are two types of heat treatment applicable to aluminum alloys. They are known as solution and precipitation heat treatment. Certain alloys develop their full strength from the solution treatment, while others require both treatments for maximum strength.

The NA 01-1A-9 lists the different temper designations assigned to aluminum alloys and gives an example of the alloys using these temper designations.

SOLUTION HEAT TREATMENT.—The solution treatment consists of heating the metal to the temperature required to cause the constituents to go into a solid solution. To complete the solution, often the metal is held at a high temperature for a sufficient time, and then quenched rapidly in cold water to retain this condition. It is necessary that solution heat treatment of aluminum alloys be accomplished within close limits in reference to temperature control and quenching. The temperature for heat-treating is usually chosen as high as possible without danger of exceeding the melting point of any element of the alloy. This is necessary to obtain the maximum improvement in mechanical properties. If the maximum specified temperature is exceeded, eutectic melting will occur. The consequence will be inferior physical properties, and usually a severely blistered surface. If the temperature of the heat treatment is low, maximum strength will not be obtained.

PRECIPITATION (AGE) HARDENING.—The precipitation treatment consists of "aging" material previously subjected to solution heat treatments by natural (occurs at room temperature) or artificial aging. Artificial aging consists of heating aluminum alloy to a specific temperature and holding for a specified length of time. During this hardening and strengthening operation, the alloying constituents in solid solution precipitate out. As precipitation progresses, the strength of the material increases until the maximum is

reached. Further aging (overaging) causes the strength to decline until a stable condition is obtained. The strengthening of the material is due to the uniform alignment of the molecule structure of the aluminum and alloying element.

Artificially aged alloys are usually slightly "overaged" to increase their resistance to corrosion, especially the high copper content alloys. This is done to reduce their susceptibility to intergranular corrosion caused by underaging.

Natural aging alloys can be artificially aged; however, it increases the susceptibility of the material to intergranular corrosion. If used, it should be limited to clad sheet and similar items.

Quenching

The basic purpose for quenching is to prevent the immediate re-precipitation of the soluble constituents after heating to solid solution. To obtain optimum physical properties of aluminum alloys, rapid quenching is required. The recommended time interval between removal from the heat and immersion is 10 seconds or less. Allowing the metal to cool before quenching promotes intergranular corrosion and slightly affects the hardness. There are three methods employed for quenching. The one used depends upon the item, alloy, and properties desired.

COLD WATER QUENCHING.—Small parts made from sheet, extrusions, tubing, and small fairings are normally quenched in cold water. The temperature before quenching should be 85°F or less. Sufficient cold water should be circulated within the quenching tanks to keep the temperature rise under 20°F. This type of quench will ensure good resistance to corrosion, and is particularly important when heat-treating 2017 and 2024 alloys.

HOT WATER QUENCHING.—Large forgings and heavy sections can be quenched in hot or boiling water. This type of quench is used to minimize distortion and cracking, which are produced by the unequal temperatures obtained during the quenching operation. The hot water quench will also reduce residual stresses, which improves resistance to stress corrosion cracking.

SPRAY QUENCHING.—Water sprays are used to quench parts formed from alclad sheets and large sections of most alloys. Principal reasons for using this method are to minimize distortion and to alleviate quench cracking. This system is not usually used to

quench bare 2017 and 2024 due to the effect on their corrosion resistance.

Annealing

Annealing serves to remove the strain hardening that results from cold working and, in the case of the heat-treated alloys, to remove the effect of the heat treatment. Annealing is usually carried out in air furnaces, but salt baths may be used if the melting point of the bath is low enough. A bath made up of equal parts by weight of sodium nitrate and potassium nitrate is satisfactory.

ANNEALING OF WORK HARDENED MATERIAL.—Annealing of material that was initially in the soft or annealed condition but which has been strain-hardened by cold working, such as 1100, 3003, 5052, etc., is accomplished by heating the metal to a temperature of $349 \pm 5^\circ\text{C}$ ($660 \pm 10^\circ\text{F}$). It is only necessary to hold the metal at this temperature for a sufficient length of time to make certain that the temperature in all parts of the load has been brought within the specified range. If the metal is heated appreciably above 354°C (670°F), there is a partial solution of the hardening constituents, and the alloy will age harden while standing at room temperature unless it has been cooled very slowly. If the temperature is not raised to 343°C (650°F), the softening may not be complete. The rate of cooling from the annealing temperature is not important. However, a slow cool is desirable in case any part of the load may have been heated above the recommended temperature range.

ANNEALING OF HEAT-TREATED ALLOYS.—The heat-treatable alloys are annealed to remove the effects of strain hardening or to remove the effects of solution heat treatment.

To remove strain hardening due to cold work, a 1-hour soak at 640° to 660°F , followed by air-cooling, is generally satisfactory. This practice is also satisfactory to remove the effects of heat treatment if the maximum of softness is not required.

To remove the effects of partial or full heat treatment, a 2-hour soak at 750° to 800°F , followed by a maximum cooling rate of 50° per hour to 500°F , is required to obtain maximum softness.

To remove the effects of solution heat treatment or hardening due to cold work, the high zinc-bearing alloy 7075 should be soaked 2 hours at 775°F , air cooled to 450° , and soaked 6 hours at 450° . The stabilizing

temperature at 450° is necessary to precipitate the soluble constituents from solid solution.

The annealing of solution heat-treated material should be avoided whenever possible if subsequent forming and drawing operations are to be formed. If such operations are not severe, it is generally advantageous to repeat the solution heat treatment and form the material in the freshly quenched condition.

- Q6-72. *What is the only metal that cannot be hardened by heat-treatment?*
- Q6-73. *Uneven heating of metal often causes what actions to occur?*
- Q6-74. *The slow heating of metal ensures what condition?*
- Q6-75. *The heating rate for hardened tools and parts should be slower than metals that are in what condition?*
- Q6-76. *What is the process of holding a metal at a temperature until it is heated throughout and changes have had time to take place?*
- Q6-77. *How can you reduce the distortion and cracking of metal?*
- Q6-78. *The process for rapidly cooling heated metal is known by what term?*
- Q6-79. *Alloy steels are generally hardened by cooling with what substance?*
- Q6-80. *The form of heat-treatment used to reduce residual stresses, induce softness, and alter ductility is known by what term?*
- Q6-81. *The process in which an iron-based metal is allowed to cool at room temperature, in still air, after being heated to approximately 100°F is known by what term?*
- Q6-82. *The process of quenching a metal after it is heated to a temperature slightly above the critical temperature is known by what term?*
- Q6-83. *The process by which steel is heated to just below critical and held there for a period of time, and then cooled with oil, water, or brine is known by what term?*

- Q6-84. *What is the process of producing a hard case over a tough core known as?*
- Q6-85. *The process of hardening steel by introducing carbon to the heated metal is known by what term?*
- Q6-86. *The process of hardening alloy steel by holding it at temperatures below the critical point in anhydrous ammonia is known by what term?*
- Q6-87. *The carbon in steel, which exists as particles of iron carbide, scattered throughout the iron mixture is known by what term?*
- Q6-88. *If the cooling is slow, the carbon particles are relatively coarse and few. In what condition will this leave the steel?*
- Q6-89. *Before steel can be hardened completely, it must be heated to a certain point, before it is rapidly quenched. What is this point called?*
- Q6-90. *If you don't have an instrument to determine the temperature of steel being heated, you can judge it by what factor?*
- Q6-91. *What term describes an aluminum alloy with a protective coating of aluminum?*
- Q6-92. *What increases artificially aged alloys' resistance to corrosion?*
- Q6-93. *What is the recommended time interval between removal from the heat and immersion during the quenching process?*
- Q6-94. *Small aluminum parts are normally quenched in what substance to ensure good resistance to corrosion?*
- Q6-95. *What quenching method is used to quench large forgings to prevent cracking and minimize distortions?*
- Q6-96. *The process of removing the effects of heat-treatment in alloys is referred to by what term?*
- Q6-97. *It takes a 2-hour soak at 750° to 800°F, followed by a maximum cooling rate of 50° per hour to 500°F to remove the effects of a partial or full heat-treatment and obtain what condition?*

CHAPTER 7

AIRCRAFT WHEELS, TIRES, AND TUBES

INTRODUCTION

Modern aircraft wheels are among the most highly stressed parts of an aircraft. High tire pressures, cyclic loading, corrosion, and physical damage contribute to failure of aircraft wheels. Complete failure of an aircraft wheel can be catastrophic. When wheel failure occurs, the fragments are often propelled several hundred feet. You must have the ability to identify potential safety hazards when you work on aircraft tires and wheel assemblies. You must practice all the safety precautions related to wheel and tire maintenance procedures. At the organizational maintenance level, aircraft wheels are removed frequently for tire changes, inspections, and lubrication. Familiarity with various types of wheels and tires, and related safety precautions, will increase your ability to perform your duties.

AIRCRAFT WHEELS

LEARNING OBJECTIVES: Recognize the components of the different types of wheels. Identify the maintenance responsibilities of both the O-level and I-level maintenance activities.

Aircraft wheels are made from either aluminum or magnesium alloys. These materials provide a strong, lightweight wheel that requires very little maintenance. The wheels used on naval aircraft are of two general types—divided and demountable flange. Both of these designs make wheel buildup a fairly simple operation.

The wheels used with tires and tubes have knurled flanges to prevent the tire from slipping on the wheel. Wheels used with tubeless tires have the wheel sections sealed by an O-ring, and they use special valves that are a part of the wheel.

DIVIDED (SPLIT) WHEEL

Figure 7-1 shows a typical divided (split) wheel. This type of wheel is divided into two halves. The two halves are sealed by an O-ring and held together with nuts and bolts. Each wheel half is statically balanced. This procedure allows any two opposite halves of the same size and type to be joined together to form one wheel assembly. If the outboard half of a wheel is beyond repair, a new outboard half may be drawn from supply. The new outboard half is then matched to the old inboard half. This type of wheel is used on nose, main, and tail landing gears.

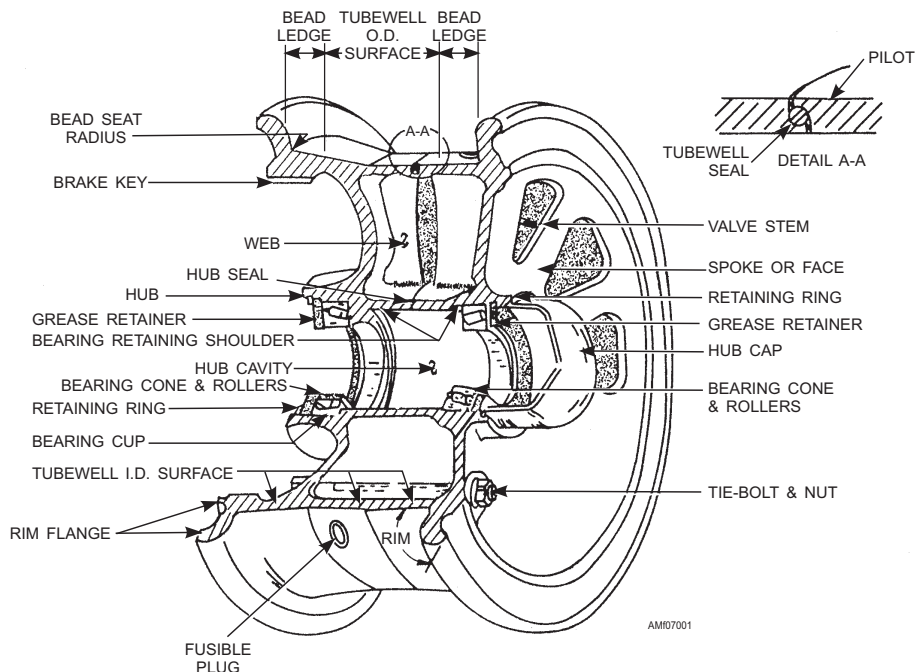

Figure 7-1.—Typical divided (split) wheel assembly.

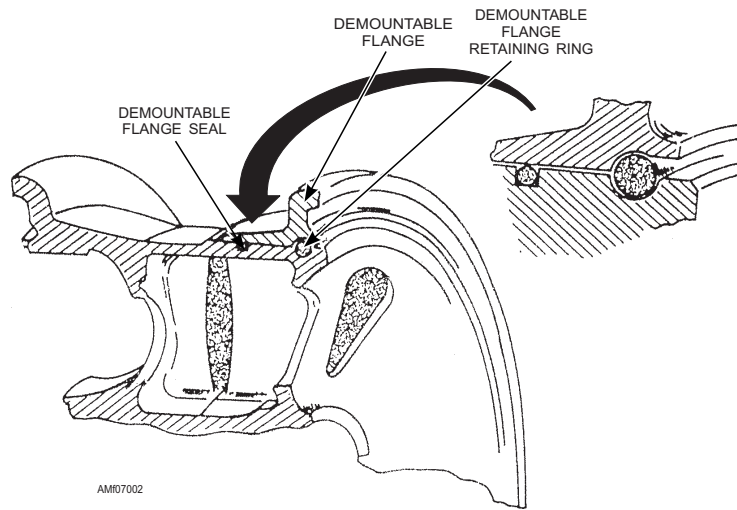

Figure 7-2.—Demountable flange wheel.

DEMOUNTABLE FLANGE WHEEL

The demountable flange wheel is made so one flange of the wheel can be removed to change the tire. The flange is held in place by a locking.

The wheel is balanced with the flange mounted on the wheel. Then, both the wheel and flange are marked. To ensure proper balance of the wheel during assembly, the two marks should be lined up. Figure 7-2 shows a typical demountable flange wheel. This type of wheel is commonly used on the main landing gear.

The similarity of one wheel to another in size and shape is not proof that the wheels can be interchanged. One wheel may be designed for heavy duty while the

other may be designed to carry a lighter load. Also, the wheels may be designed for use with different types of brake assemblies.

TYPICAL WHEEL ASSEMBLY

A complete wheel assembly is shown in figure 7-3. The wheel casting is the basic unit of the wheel assembly. It is to this part that all other components are assembled and upon which the tire is mounted.

The demountable flange is attached to the wheel to simplify tire removal and installation. The demountable flange locking secures the flange to the wheel. The flange is fitted into a groove in the wheel casting.

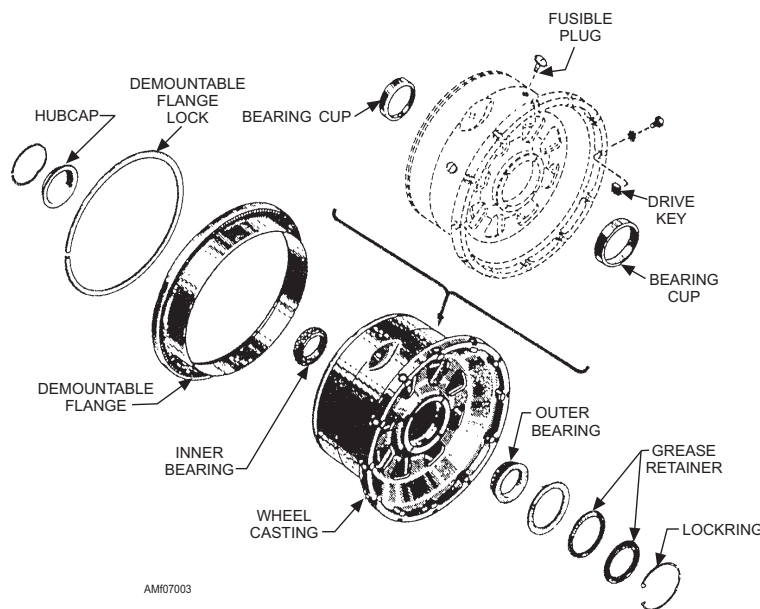

Figure 7-3.—Typical wheel assembly.

The bearing cups are shrink-fitted into the hub of the wheel casting; the bearing cups are the parts on which the bearings ride. The bearings are tapered roller bearings. Each bearing is made of a cone and rollers. This type of bearing absorbs side thrust as well as radial loads and landing shocks. These bearings must be cleaned and lubricated in accordance with the NAVAIR 04-10-1 manual.

A three-piece grease retainer keeps the grease in the inboard bearing and keeps out dirt and moisture. The retainer is composed of a felt seal and inner and outer closure rings. A lockring secures the assembly inside the wheel hub.

The hubcap seals the outboard side of the hub. It is secured with a lockring. On some aircraft, the hubcap is secured with screws.

All wheels designed to be used on the main landing gear are equipped with braking components. These components are attached to the wheel casting. They may consist of either a brake drum or brake drive keys. The wheel shown in figure 7-3 is equipped with drive keys. This wheel is designed for disc brakes.

The trend in the military is toward smaller, faster, more powerful aircraft with increased load carrying capabilities. This means heavier loads and higher landing speeds. The friction of long landing rollouts and taxiing causes heat to be absorbed by the wheel. Because of the heat, possible wheel failure may occur. This may damage equipment and injure personnel. To prevent this situation, aircraft manufacturers have developed a safety device called a "fusible plug." The fusible plug contains an alloy that will melt and permit the tire to deflate. This action occurs in the event the wheel is exposed to excessive heat. Wheels that contain fusible plugs should have a metal tag affixed that reads "Fusible Plugs Installed."

ORGANIZATIONAL-LEVEL TIRE AND WHEEL MAINTENANCE

Corrosion and loss of bearing lubrication are two of the major causes of failure or rejection of aircraft wheels. It is extremely important that all organizational maintenance activities take precautions to protect aircraft wheels/bearings from water, particularly salt water. Wheel bearing lubrication gets contaminated and/or breaks down, from excessive heat and water, more often than it is lost. When wheels are exposed to a stream of water (such as a hose), it will usually penetrate the hub area, contaminating the bearing lubricant. This contributes to corrosion in the bearing

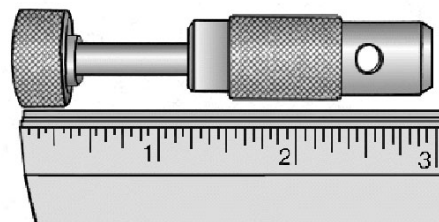

AM107004

Figure 7-4.—Safe-core valve tool.

area. All wheel bearings should be lubricated at every tire change, and as required by the applicable maintenance requirements cards (MRCs). All wheel and bearing assemblies should be removed according to the applicable maintenance instruction manual (MIM) for that specific aircraft.

WARNING

When a wheel is to be removed from an aircraft, the nitrogen or dry air must be removed from the tire prior to removing the wheel. This should be done with the Palmer Safe-Core valve tool (P/N 968RB), which traps the valve core in the body of the Palmer Safe-Core valve tool. See figure 7-4. This precaution must be taken because of the possibility that the bolts in split wheels might have been sheared and cause the wheel halves to separate when the axle nut is removed. A tire deflated (valve core removed) metal tag should be installed on the valve stem prior to removing the wheel from the axle. See figure 7-5. Several people have been killed because they failed to remove the air from the tire before removing the axle nut.

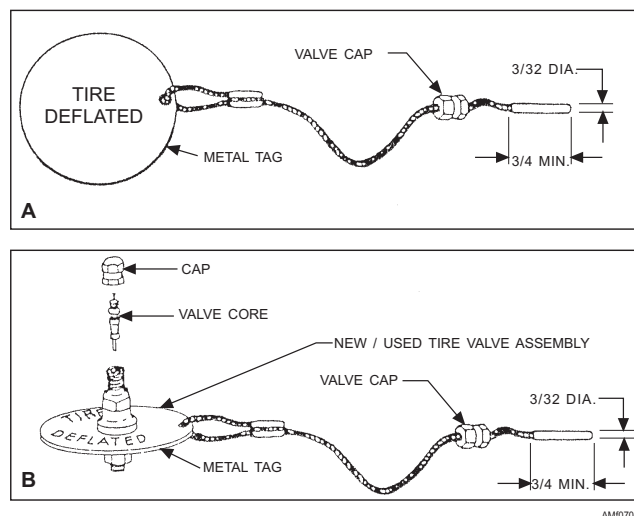

AM107005

Figure 7-5.—(A) Deflated tire flag, (B) Storage of valve core and cap using alternate deflated tire flag.

Cleaning

You should clean bearings, bearing cups, wheel bores, and grease retainers with P-D-680, type II solvent, in accordance with NA 04-10-1, to remove all traces of the grease, preservative compounds, and contamination. Treat bearings with fingerprint neutralism (MIL-C-15074) by immersing and agitating for 2 to 3 minutes. Dry the bearings and the hub area with compressed air. Be careful not to spin the unlubricated bearings. You should perform a visual inspection of the bearings, bearing retainers, and bearing cups with a 10X magnifier. Replace all excessively worn, dented, scored, or pitted bearing cups. Most bearing cups will display some wear. This is not cause for replacement as long as no step can be felt and there are no dents, scores, or definite corrosion pits. Some cups will have a light gum or surface corrosion deposit that can be removed by lightly polishing with abrasive webbing (MIL-A-9962). Do not use a coarse abrasive and do not remove the base material. After polishing the bearing cup, you should thoroughly clean the bearing cup and wheel bore to remove all deposits. Reinspect the polished bearing cups for defects, and replace them if necessary. Any obvious defects on bearing cone and roller assemblies, including cracks in the bearing retainer, are cause for replacement.

Lubrication

You should repack the bearings with MIL-G-81322 grease. Spread a thin layer of grease on bearing cups. Inspect the rubber grease retainers for evidence of deterioration. Inspect the felt grease retainers for deterioration, contamination, or water saturation. Replace them if necessary. Freshwater-saturated felt retainers may be dried and reused if they are otherwise serviceable. Saltwater contaminated felt seals must be replaced. You should presoak felt retainers with VV-L-800 oil prior to their installation. Reinstall the wheel on the aircraft according to the applicable maintenance instruction manual (MIM).

Installation

When you reinstall the wheel on the aircraft, the proper adjustment of the bearings is extremely important. The following general rules apply to wheel installation:

1. Tighten the axle nut while you spin the wheel with your hand.

2. When the wheel no longer spins freely, back off the axle nut one castellation (one-sixth turn). When properly installed and adjusted, the wheel will turn freely, but will not move sidewise.

NOTE: This procedure may vary from one aircraft to another. Some aircraft require a specific torque to be applied to the axle nut. In these cases, you should refer to the applicable MIM.

3. Install the appropriate axle nut safety device.
4. Install and lock the hubcap in place.

There are some inboard bearings that do not need to be removed except to be replaced. These bearings are listed in table 3-2 of *Aircraft Wheels*, NAVAIR 04-10-1.

Safety Training

When you perform tire and wheel maintenance, you should handle inflated and partially inflated wheel assemblies with the same respect and care as live ordnance because of the destructive potential of a gas under pressure.

If tire and wheel maintenance is performed within your command, the command should conduct appropriate training. The minimum requirements for the training program should include the following:

- QAR supervised tire and wheel assembly removal and replacement.
- QAR supervised wheel bearing cleaning and lubrication.
- QAR administered examinations.
- NAVAIR publications familiarization training.
- Display of tire and wheel safety posters in the work centers. (See figure 7-6.)
- Documentation of completed training.

INTERMEDIATE-LEVEL WHEEL MAINTENANCE

One of the responsibilities of an intermediate maintenance activity (IMA) is to determine wheel overhaul requirements. Other IMA responsibilities include painting, cleaning, inspection (lubrication), corrosion and physical damage blendout, and wheel half mismatching.

AIRCRAFT TIRES - TUBES - WHEELS

INFLATION/DEFLATION SAFETY PRECAUTIONS

Before performing a maintenance or servicing action on a tire and wheel assembly, STOP and ask yourself these questions:

1. Have I read NAVAIR 04-10-506 Technical Manual for Aircraft Tires and Tubes?
2. Have I read the applicable Aircraft Maintenance Instruction Manual concerning this particular wheel and tire assembly?
3. Do I thoroughly understand what I have read, particularly the hazards associated with high pressure gases?
4. Do I thoroughly understand the procedures required to inflate or deflate tires?
5. Am I fully qualified for the task in accordance with current directives?

DO NOT attempt maintenance/service if your answer is NO to any of the above questions!

Inflation

NOTE: Water Pumped Nitrogen shall be used to inflate all tires.
The use of dry, oil-free air should only be used when Nitrogen is not available.

Tires not mounted on aircraft shall be inflated only in a tire cage.

Tires on aircraft shall not be inflated to operating pressure until axle nut is secured properly against wheel bearings.

Hi-pressure sources shall be equipped with reducing valves that limit line pressure to 50 percent above maximum tire inflation pressure, or 600 PSI, whichever is lesser.

Do not modify hose couplings, valve stem adapter, or substitute adapter valve core.

Do not abuse remote control inflator gage.

Use the correct remote inflator gage assembly after ensuring it has been calibrated (within the last 30 days) in accordance with the latest metrology directives. Do not tamper with relief valve setting.

Clear the tire inflation area of loose objects (20 ft. radius).

Clear the area of other personnel.

Adjust pressure regulator to 50 percent above maximum tire pressure or 600 PSI whichever is lesser.

Under no circumstances shall the setting on the regulator exceed 600 PSI.

Ensure that all inflation hose couplings are tightly connected.

Stand as far away as the inflator hose will permit (10 ft.) and in a line either fore or aft of the wheel.

Open the source valve slowly. Inflate tire in 10 PSI increments to desired pressure — DO NOT OVER INFLATE! If over-inflation occurs, open bleeder valve on inflation gage to release pressure.

Allow tire to stabilize a few minutes before disconnecting hose at valve stem.

Replace valve cap on valve stem.

Removal and Disassembly

Prior to removing wheel/tire assembly from the aircraft, completely deflate tire with an approved tire deflator tool. When deflated, remove valve core and install "Deflated Tire Flag" in accordance with NAVAIR 04-10-506. Break the tire beads prior to removing any wheel bolts.

- References:
1. Applicable Aircraft MIM
 2. NAVAIR 04-10-506 Technical Manual for Aircraft Tires and Tubes
 3. NAVAIR 04-10-1 Technical Manual for Aircraft Wheels
 4. NAVAIR 17-1-123 Technical Manual for Tire Inflator Assembly, Remote Inflator Assembly and Dual Chuck Stem Gage

C12GI 1163 (REV. SEPT. 82)

This poster supersedes poster C12GI 1163 (Rev. JUL 1978) which contains obsolete information and should be destroyed.

Prepared by
Naval Safety Center
Naval Air Station
Norfolk, Virginia 23611

AMF07006

Figure 7-6.—Aircraft tires-tubes-wheels safety poster.

Painting

When the wheel paint has deteriorated to the extent that touch-up is not feasible, wheels may be stripped and repainted. Stripping and repainting are allowed only if the IMA is authorized to paint with aliphatic polyurethane.

Cleaning

To inspect aircraft wheels for cracks, physical damage, and corrosion, they must be clean. All dirt, rubber, and grease deposits must be completely removed. Cleaning for appearance sake is not a requirement. Removing stains is not a necessity. Many wheels will be discolored after the rubber deposits have been removed from the tire bead areas. This discoloration is acceptable, and further cleaning is not necessary. Discolored areas around brake keys are difficult to remove without damaging the paint.

The following steps describe the wheel cleaning procedures. Further information regarding the cleaning of aircraft wheels can be found in *Aircraft Wheels*, NAVAIR 04-10-1.

Clean the wheels as follows:

1. Prepare one tank (solution A) of cleaning solution that consists of 4 to 9 parts cleaning solvent (P-D-680) and 1 part solvent emulsion cleaner (P-C-444).

2. Prepare another tank (solution B) of cleaning solution that consists of 4 to 9 parts of clean water and 1 part emulsion cleaner (MIL-C-43616).

WARNING

You should use P-D-680 solvent only in well-ventilated areas. You should also avoid skin contact by wearing protective equipment for your eyes and hands.

3. Place the wheel portion to be cleaned on a grill over solution A, and spray it thoroughly with solution A to remove all loose grease and soil.

4. Immerse the wheel portion in solution A, and allow it to soak for 20 minutes.

5. Repeat step 3, and then scrub the tire bead areas with bristle brushes to remove the rubber deposits. Do not use wire brushes.

6. Thoroughly dry the wheel with compressed air.

7. Immerse the wheel portion in solution B, and allow it to soak for 20 minutes.

8. Place the wheel portion on a grill over solution B, and spray it thoroughly with solution B. Remove any remaining soil or grease deposits with liberal amounts of solution B and bristle brushes.

9. Thoroughly wash the wheel portion with a high-pressure stream of clean water to remove all solvents. Compressed air may be used to dry the wheel.

Inspection

You should perform a visual inspection of the wheel for cracks, loose bearing cups, corrosion, physical damage, and melted fusible plugs. See figure 7-7. Forward all wheels with cracks or loose bearing cups to supply for overhaul. Partially melted fuse plugs should not cause a wheel to be rejected. The plug may not need to be replaced. If the eutectic core material does not extend more than one-sixteenth of an inch above the top surface of the hex head, the plug may be kept in service "as is" with no restrictions. If the eutectic core material at the threaded end is not depressed more than one-sixteenth of an inch and there is no evidence of pinholes, the plug may be kept in service with no restrictions. Do not file, sand, or remove the eutectic material. If the eutectic material appears to be filed, sanded, or broken, you should assume the serviceable limits have been exceeded and reject the plug.

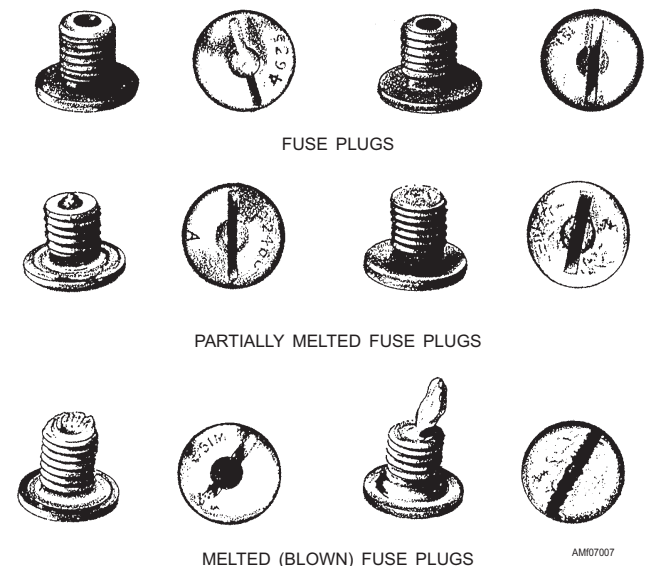

Figure 7-7.—Fuse plugs.

You should perform the eddy current and dye penetrant inspections for wheels listed in NAVAIR 04-10-1. Inspect all tie bolts for corrosion, elongation, bending, stripped threads, or deformed shanks. You should also perform a magnetic particle inspection for cracks according to NAVAIR 01-1A-16. Any of the listed defects is cause for rejection of the tie bolt. Self-locking tie bolt nuts may be reused provided the nut cannot be turned onto the tie bolt by hand with the fingertight method prescribed in *Structural Hardware*, NAVAIR 01-1A-8. On disc wheels, you should inspect brake keys or gears for wear and looseness in accordance with NA 04-10-1. Replace worn brake keys and gears or reattach loose brake keys and gears in accordance with NA 04-10-1. Corrosion or rust on brake keys and gears is common, and is not cause for rejection.

Bearing Maintenance

You should remove and inspect the bearing cone and roller assemblies according to the applicable MIM. Thoroughly clean the bearings, bearing cups, wheel bores, and grease retainers with P-D-680, type II, solvent to remove the grease, preservative compounds, and contamination.

NOTE: The organizational-level and intermediate-level procedures for cleaning and inspecting wheel bearings, retainers, cups, and cone and roller assemblies are the same.

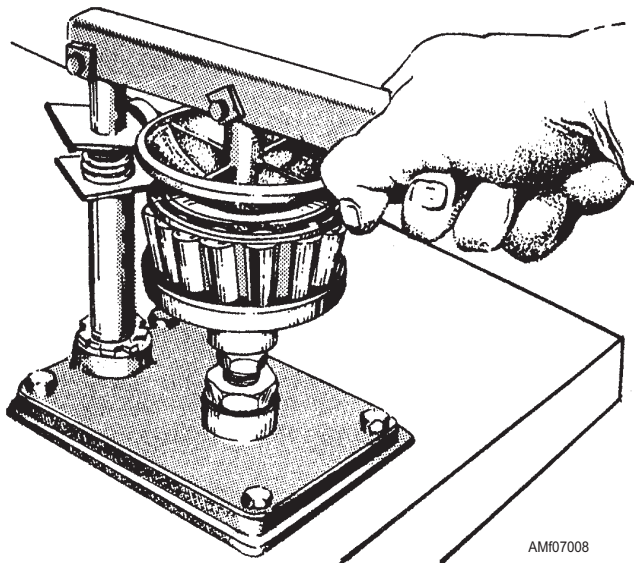

Figure 7-8.—Pressure repacking of wheel bearings.

You should repack bearings with MIL-G-81322 grease. Bearings may be repacked either with pressure equipment or by hand. See figures 7-8 and 7-9. The pressure method is recommended because it is easier, faster, and reduces the possibility of contamination. The pressure method assures a more even distribution of grease within the bearing.

NOTE: You should ensure bearings are completely dry before packing them with lubricant.

You should also spread a thin layer of grease on the bearing cups. Inspect the grease retainers for evidence of deterioration, contamination, or water saturation. You should replace them if necessary. Presoak the retainers with VV-L-800 oil prior to installing them.

Refer to the NA 01-1A-503 manual for more detailed information on wheel bearing maintenance.

Corrosion and Physical Damage Blendout

Limited and isolated corrosion and physical damage should be blended. Wheel rims, outside ends of bearing hubs, nicks, gouges, and pock marks are not considered significant unless the defect is deeper than 0.020 of an inch. The defect should not be blended out unless there is active corrosion in the defect. However, all burrs must be removed. Corrosion or other defects should be blended out not to exceed a maximum of one-sixteenth of an inch. All damage must be removed within this allowance. The maximum depth of blendout for all other wheel areas is 0.010 of an inch.

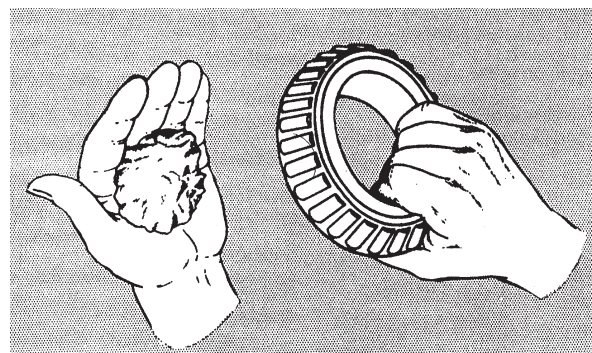
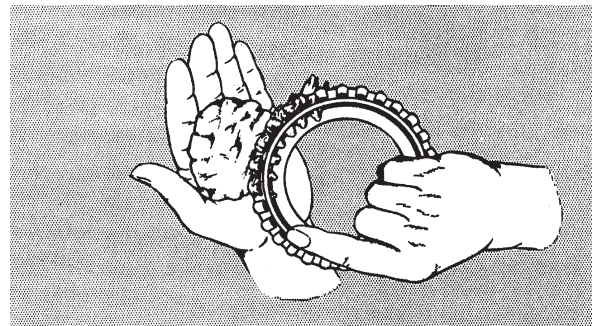

Figure 7-9.—Hand repacking of wheel bearings.

The rims, bearing hub ends, and tire bead area can be blended out with a medium or fine cut, half-round or round file. You should lightly file the damaged area to remove the defects. After the defects have been removed, you should hand polish the areas with 320 or finer grit aluminum oxide (P-C-451). All file marks should be removed. The areas should be painted according to NAVAIR 04-10-1 and NAVAIR 01-1A-509.

Matching Wheel Halves

Split rim wheels are manufactured and assembled as a matched assembly. Each half will have the same serial number. If a wheel half is rejected at the IMA, the remaining half may be matched to a serviceable replacement to make a complete assembly. When you combine unmatched wheel halves, each half must have the same part number. Every effort should be made to keep the manufacture dates of each half as close as possible. Each half of this wheel assembly will now have different serial numbers, which is acceptable.

- Q7-1. *Aircraft wheels are made from what two materials?*
- Q7-2. *What are the two general types of wheels used on naval aircraft?*
- Q7-3. *On a demountable flange wheel, what holds the flange in place?*
- Q7-4. *What is the basic unit of an aircraft wheel assembly?*
- Q7-5. *All main landing gear wheel braking components are attached to the wheel casting. What do these components consist of?*
- Q7-6. *What are the two major causes of aircraft wheel failures?*
- Q7-7. *What solvent should be used to clean bearings, bearing cups, wheel bores, and grease retainers?*
- Q7-8. *Before installing felt grease retainers, what should you soak them in?*
- Q7-9. *During wheel installation, how far do you back off the axle nut when the wheel no longer spins freely?*
- Q7-10. *Where can you find the procedures for aircraft wheel installation?*
- Q7-11. *What activity determines wheel overhaul requirements?*

- Q7-12. *To what manual should you refer to find information on cleaning aircraft wheels?*
- Q7-13. *A fuse plug can be kept in service if the eutectic core material does NOT extend what maximum distance above the surface of the hex nut?*
- Q7-14. *What grease should you use to repack wheel bearings?*
- Q7-15. *What is the recommended method for repacking bearings?*
- Q7-16. *Gouges, nicks, and pockmarks on the outside ends of bearing hubs are considered significant if they exceed what depth?*

AIRCRAFT TIRES

LEARNING OBJECTIVES: Recognize the procedures for dismounting, mounting, and inflating aircraft tires. Identify various tire markings. Determine preventive maintenance requirements indicated by tire tread wear.

Proper care and maintenance of tires have always been important items in aircraft maintenance. Because of the modern fast-landing aircraft, careful tire maintenance has become increasingly important. Aircraft tires are built to withstand a great deal of punishment, but only by proper care and maintenance can they give safe and dependable service.

The dimensions used to identify wheels are not necessarily the dimensions of the wheels themselves. Instead, they refer to dimensions of the tire.

TIRE CONSTRUCTION

Figure 7-10 shows the construction details of a tube-type aircraft tire. Tubeless tires are similar to tube tires except they have a rubber inner liner that is mated to the inside surface of the tire. The rubber liner helps retain air in the tire. The beaded area of a tubeless tire is designed to form a seal with the wheel flange. Wear indicators have been built into some tires as an aid in measuring tread wear. These indicators are holes in the tread area or lands in the bottom of the tread grooves.

The *cord body* consists of multiple layers of nylon with individual cords arranged parallel to each other and completely encased in rubber. The cord fabric has its strength in only one direction. Each layer of coated fabric constitutes one ply of the cord body. Adjacent cord plies in the body are assembled with the cords crossing at nearly right angles to each other. This

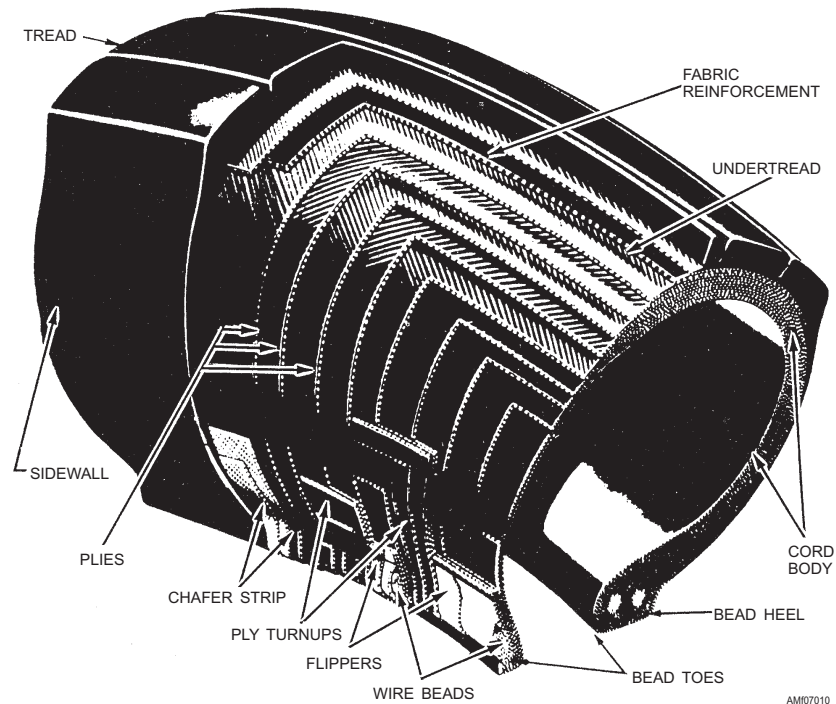

Figure 7-10.—Sectional view of aircraft tire showing construction details.

arrangement provides a strong and flexible tire that distributes impact shocks over a wide area. The functions of the cord body are to give the tire tensile strength, to resist internal pressures, and to maintain tire shape.

The *tread* is a layer of rubber on the outer surface of the tire. It protects the cord body from abrasion, cuts, bruises, and moisture. It is the surface that contacts the ground.

The *sidewall* is an outer layer of rubber adjoining the tread and extending to the beads. Like the tread, it protects the cord body from abrasion, cuts, bruises, and moisture.

The *beads* are multiple strands of high-tensile strength steel wire imbedded in rubber and wrapped in strips of open weave fabric. The beads hold the tire firmly on the rims and serve as an anchor for the fabric plies that are turned up around the bead wires.

The *chafing strips* are one or more plies of rubber-impregnated woven fabric wrapped around the outside of the beads. They provide additional rigidity to the bead and prevent the metal wheel rim from chafing the tire. Tubeless tires have an additional ply of rubber over the chafing strips to function as an air seal.

The *breakers* are one or more plies of cord or woven fabric impregnated with rubber. They are used between the tread rubber and the cord body to provide extra reinforcement to prevent bruise damage to the tire. Breakers are not part of the cord body.

Tread Patterns

There are three tread patterns or tread designs used on naval aircraft. They are plain, ribbed, and nonskid. A plain tread has a smooth, uninterrupted surface. A ribbed tread has three or more continuous circumferential ribs separated by grooves. A nonskid tread is any grooved or ribbed tread. Other tread designs may be provided under specific circumstances or as required by applicable MS standards or drawing. The most common design used on naval aircraft is the ribbed pattern.

Tread Construction

The tread construction will usually be one of four types. Other tread types may be necessary for specific circumstances or as required by military standards, such as ice and snow treads.

NOTE: Additional safety precautions are required in handling ice and snow treads.

- Rubber tread. A rubber tread is constructed from 100-percent new (no reclaim) rubber. It may be new natural rubber, new synthetic material, or a blend of new material and new synthetic materials.

- Cut-resistant tread. A cut-resistant tread has improved cut-resistant properties that are imparted to the tire by incorporating a barrier into the undertread that resists penetration of cutting objects.

- Reinforced tread. A reinforced tread is constructed with fabric cord or other reinforcing materials as an integral part of the tread. See figure 7-11.

- Reinforced cut-resistant tread. A reinforced cut-resistant tread combines the features of both the cut-resistant and reinforced-tread designs.

Ply Rating

Reference to the number of cord fabric plies in a tire has been superseded by the term *ply rating*. This term is used to identify a tire's maximum recommended load for specific types of service. It does not necessarily represent the number of cord fabric plies in a tire. Most nylon cord tires have ply ratings greater than the actual number of fabric plies in the cord body.

Tire Rebuilding/Retreading

The rebuilding of aircraft tires has been practiced for many years. A rebuilt tire is one that has a new tread section attached to a carcass or worn tire. Each rebuilt tire saves aircraft operators approximately 75 percent of the cost of a new tire. Data shows that a rebuilt tire gives service comparable to a new tire. The General Accounting Office (GAO) and the Department of Defense (DOD) policy mandates "aircraft tires will be rebuilt in all cases where economics can be realized without affecting safety of personnel and/or

equipment." The Navy has established rebuilding criteria consistent with tire technology and service experience. By using this approach, functionally sound tire carcasses are returned to qualified contractors for rebuilding. In conjunction with these procedures, Navy laboratories monitor rebuilt tires to ensure the fleet receives a satisfactory product. The military rebuilt tire is as safe as, or safer than, a new tire because it is built on a service-tested tire carcass, whereas a new tire has had no service use to establish its construction reliability and performance suitability. Rebuilt tires are subjected to quality control procedures that are far more stringent than those imposed on a new tire. Unlike a new tire, each rebuilt tire receives a final nondestructive inspection with laser beam optical holographic methods. This procedure detects separations, voids, and multiple cord fractures within the carcass, which is cause for tire rejection.

Size Designation

Figure 7-12 shows the points of measurement used to designate the size of a tire. For example, a tire with a size designation of 26 X 6.6 would have an outside diameter (measurement A) of 26 inches and a cross-sectional width (measurement B) of 6.6 inches. The letter X merely separates the two measurements. If the tire's size designation were 26 X 6.6 -10, then the tire would have a rim diameter (measurement C) of 10

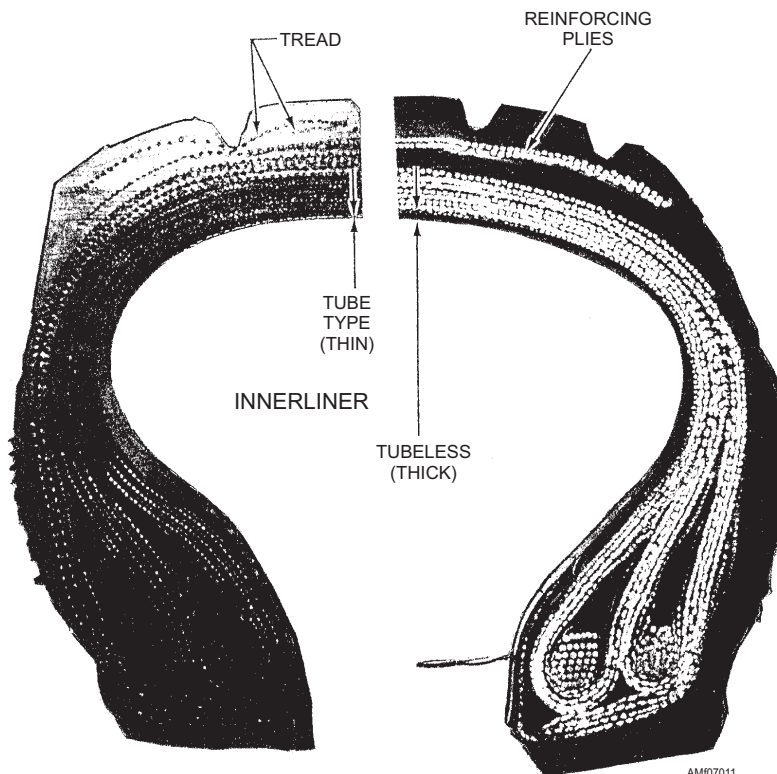
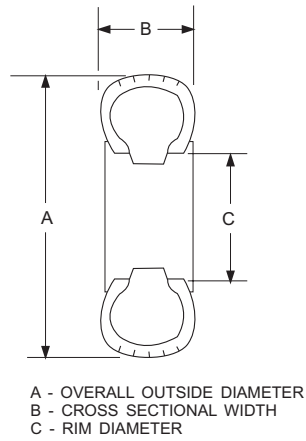

Figure 7-11.—Sectional view of two aircraft tires showing different construction details.



TIRE AND TUBE SIZES

THIS TYPICAL DIAGRAM INDICATES THE POSSIBLE DIMENSIONS SHOWN ON TIRE SIDEWALLS.

THE SYMBOL (X) IS USED BETWEEN DIMENSIONS "A" AND "B"; HENCE, 26 X 6.6" MEANS THAT THE OVERALL OUTSIDE DIAMETER IS 26" AND THE CROSS SECTION WIDTH IS 6.6"

THE SYMBOL (-) IS USED BETWEEN DIMENSIONS "B" AND "C"; HENCE, 7.50-10 MEANS THAT THE CROSS SECTION WIDTH IS 7.50" AND THE RIM LEDGE DIAMETER IS 10".

THE SYMBOL 'R' REPLACES THE (-) FOR RADIAL TIRES.

HENCE, AxB-C, OR AxB R C

AM07012

Figure 7-12.—Size designation of tires.

inches. If only one numerical designation is used for a tire, you should assume that it is the outside diameter (measurement A).

Standard Identification Markings

You should be familiar with the markings on the sidewall of a tire. You will need this information to complete a VIDS/MAF for a tire change. The markings engraved or embossed on a sidewall are shown in figure 7-13.

Most of the markings are self-explanatory. Item 10 has a maximum of 10 characters. The first four positions show the date of manufacture in the form of a

Julian date (last digit of the year followed by the day of the year, or 17 Oct 1985 = 5290). The next positions are completed by the manufacturer and are either numbers or letters. They are used to create a unique serial number for a particular tire. The cut limit (item 11) is expressed in thirty-seconds of an inch and is used to evaluate the depth of cuts in the thread area. Tires are marked with a red dot (item 14) on the sidewall to indicate the lightweight (balance) point of the tire.

Rebuilt Tires Identification Markings

In the tire rebuilding process, additional markings are engraved or embossed on the sidewall. See

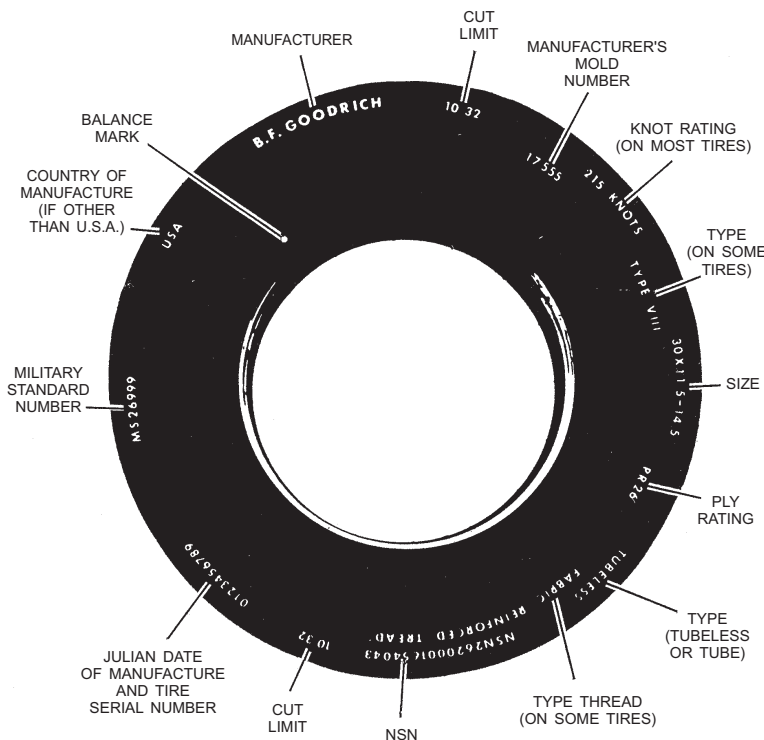

AM07013

Figure 7-13.—New tire identification markings.

figure 7-14. First, R or TR followed by a number identifies the number of times the tire has been rebuilt. Next, the Julian date of the tire's rebuilding is added. Finally, the name of the rebuilder and plant location is added.

Vent Markings

Tube tires with inflation pressures greater than 100 psi and all tubeless tires must be suitably vented to relieve trapped air. Tube tires are vented in one of two ways. The first method uses air bleed ridges on the inside tire surface and grooves on the bead faces. The ridges and grooves channel the air trapped between the inner tube and the tire to the outside. The second method uses four or more vent holes that extend completely through each tire sidewall. They relieve both pocketed air and air that accumulates in the cord body by normal diffusion through the inner tube and tire. Tube tire vent holes are marked with an aluminum- or white-colored dot.

Tubeless tires have vent holes that penetrate from the outside of the tire sidewall to the outer plies of the cord body. They relieve air that accumulates in the cord body by normal diffusion through the tubeless tire liner and the tire carcass. Vent holes in tubeless tires are marked with a bright green dot.

NOTE: Rebuilt tires may NOT have the vent holes clearly marked.

TIRE STORAGE

The life of a tire, whether mounted or unmounted, is directly affected by storage conditions. Tires should always be stored indoors in a dark, cool, dry room. It is necessary to protect them from light, especially sunlight. Light causes ultraviolet (UV) damage by breaking down the rubber compounds. The elements, such as wind, rain, and temperature changes, also break down the rubber compounds. Damage from the elements is visible in the form of surface cracking or weather checking. UV damage may not be visible. Tires can be protected from light by painting the storeroom windows. Tires must not be allowed to come in contact with oils, greases, solvents, or other petroleum products that cause rubber to soften or deteriorate. The storeroom should not contain fluorescent lights or sparking electrical equipment that could produce ozone.

Tires should be stored vertically in racks and according to size. See figure 7-15. The edges of the racks must be smooth so the tire tread does not rest on a sharp edge. Tires must never be stacked in horizontal piles. The issue of tires from the storeroom should be

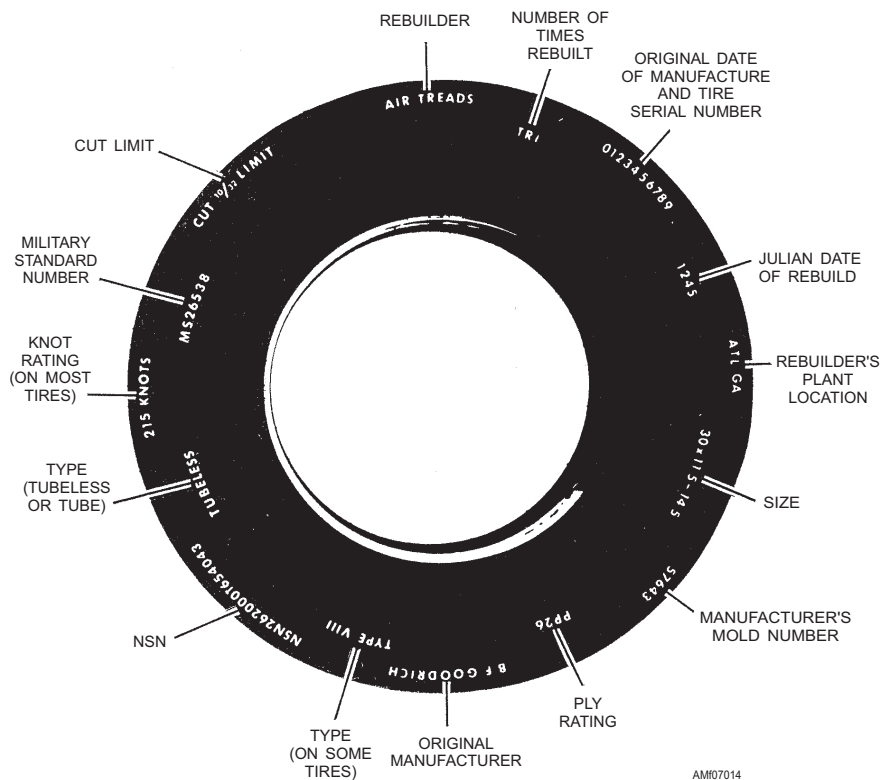

Figure 7-14.—Rebuilt tire identification markings.

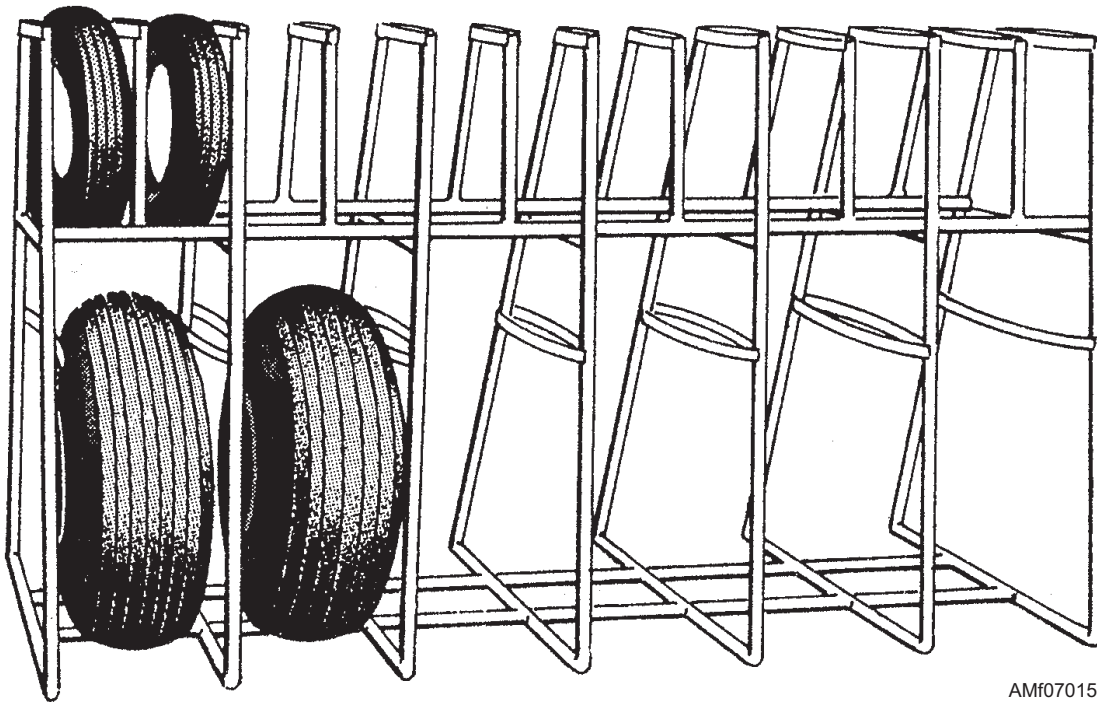

Figure 7-15.—Tire storage rack (varied size tires).

based on age from the date of manufacture so the older tires will be used first. This procedure helps to prevent the chance of deterioration of the older tires in stock.

TIRE INSPECTION

There are two types of inspections conducted on tires. One is conducted with the tire mounted on the wheel. The other inspection is conducted with the tire dismounted.

Mounted Inspection

During each daily or special inspection, tires must be inspected for correct pressure, tire slippage on the wheel (tube tires), cuts, wear, and general condition. Tires must also be inspected before each flight for obvious damage that may have been caused during or after the previous flight.

Maintaining the correct inflation pressure in an aircraft tire is essential to safety and to obtain its maximum service life. Military aircraft inner tubes and tubeless tire liners are made of natural rubber to satisfy extreme low-temperature performance requirements. Natural rubber is a relatively poor air retainer. This accounts for the daily inflation pressure loss and the need for frequent pressure checks. If this check discloses more than a normal loss of pressure, you should check the valve core for leakage by putting a

small amount of suitable leak detection solution (Leaktec) or soapy water on the end of the valve and watch for bubbles. Replace the valve core if it is leaking. If no bubbles appear, it is an indication that the inner tube (or tire) has a leak. When the tire and wheel assembly shows repeated pressure loss exceeding 5 percent of the correct operating inflation pressure, it should be removed from the aircraft and sent to the AIMD or IMA.

WARNING

Overinflation or underinflation can cause catastrophic failure of aircraft tire and wheel assemblies. This could result in injury or death to personnel, and damage to aircraft or other equipment.

After making a pressure check, you should always replace the valve cap. Be sure that it is screwed on fingertight. The cap prevents moisture, salt, oil, and dirt from entering the valve stem and damaging the valve core. It also acts as a secondary seal if a leak develops in the valve core.

Tires that are equipped with inner tubes, and operate with less than 150 psi, and all helicopter tube tires must use tire slippage marks. The slippage mark is a red paint stripe 1 inch wide and 2 inches long. It extends equally across the tire sidewall and the wheel

rim, as shown in figure 7-16. Tires should be inspected for slippage on the rim after each flight. If the markings do not align within one-fourth of an inch, the wheel assembly should be replaced and the defective assembly forwarded to the AIMD or IMA for repair. Failure to correct tire slippage may cause the valve stem to be ripped from the tube.

Tire treads should be inspected to determine the extent of wear. The maximum allowable thread wear for tires without wear depth indicators is when the tread pattern is worn to the bottom of the tread groove at any spot on the tire. The maximum allowable tread wear for tires with tread wear indicators is when the tread pattern is worn either to the bottom of the wear depth indicator or the bottom of the tread groove. These limits apply regardless of whether the wear is the result of skidding or normal use.

The tread and sidewall should be examined for cuts and embedded foreign objects. Figure 7-17 shows the method for measuring the depth of cuts, cracks, and holes. Glass, stones, metal, and other materials embedded in the tread should be removed to prevent cut growth and eventual carcass damage. A blunt awl or screwdriver may be used for this purpose. You should be careful to avoid enlarging the hole or damaging the cord body fabric.

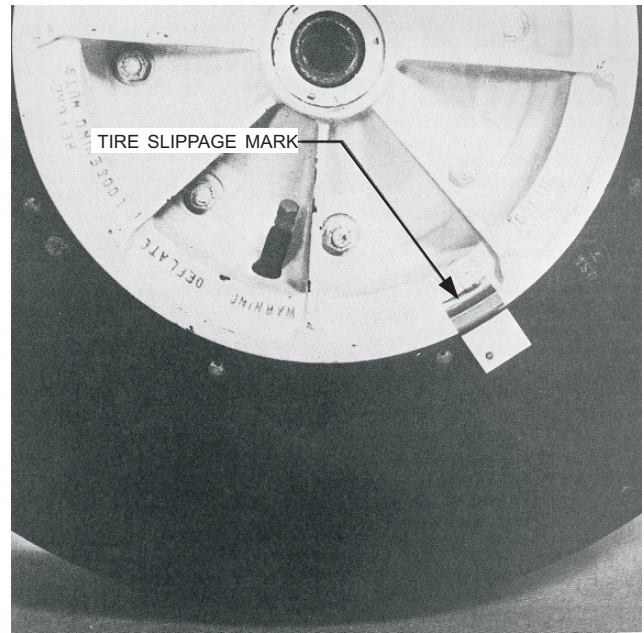

Figure 7-16.—Tire slippage mark.

Dismounted Inspection

Whenever a tire has been subjected to a hard landing or has hit an obstacle, it should be removed in accordance with the applicable MIM and dismantled for a complete inspection to determine if any internal damage has occurred. The tire beads should be spread, and the inside of the tire inspected with the aid of a light. If the lining has been damaged or there are other internal injuries, the tire should be removed from service. You should check the entire bead area and the area just above the bead for evidence of rim chafing and damage. Check the wheel for damage that may damage the tire after it is mounted.

AIRCRAFT TIRE MAINTENANCE

Aircraft tire inspection and maintenance have become more critical through the years because of

WARNING

When you are probing for foreign objects, be sure you keep the probe from penetrating deeper into the tire. Objects being pried from the tire frequently are ejected suddenly and with considerable force. To avoid eye injury, you should wear safety glasses or a face shield. You can place a gloved hand over the object to deflect it.

Aircraft should not be parked in areas where the tires may stand in spilled hydraulic fluids, lubricating oils, fuel, or organic solvents. If any of these materials is accidentally spilled on a tire, it should be immediately wiped with a clean, absorbent cloth. The tires should then be washed with soap and thoroughly rinsed with water.

You should take extra care when you inspect mounted helicopter tires. Because of the long intervals between tire changes, helicopter tires are subject to weather and UV damage.

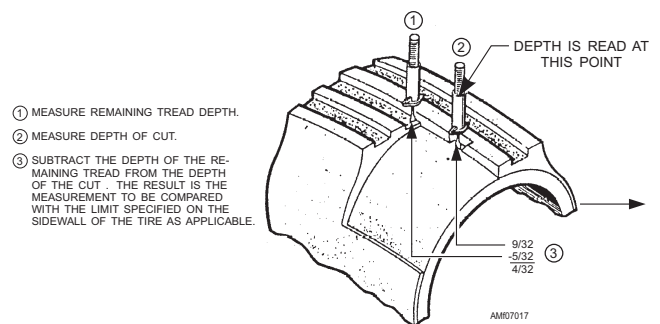

Figure 7-17.—Method of measuring depth of cuts, cracks, and holes.

increased aircraft weight and higher landing and takeoff speeds. Carrier operations place extra demands on the tire maintenance. In many cases tire failures are attributed to material failures and/or manufacturing defects when actually improper maintenance was the underlying cause. Poor inspection, improper buildup, operation of tires in an underinflated or overinflated condition are common causes for tire failure. Strict adherence to proper inspection procedures and maintenance instructions is mandatory. This will ensure that sound tires with minor discrepancies will not be removed prematurely, unsafe tires will be replaced before flight, and worn tires will be removed at the proper time to permit rebuilding.

During the mounting, dismounting, and inflating of tires, safety is paramount. Compressed air and nitrogen present a safety hazard if the operator is not aware of the proper operation of the inflation equipment and the characteristics of the inflation medium. It is also very important to know the wheel type and be familiar with the manufacturer's recommended procedure before you attempt to dismount a tire. For specific precautions concerning a particular installation, you should always consult the applicable MIM.

Dismounting

In the tire shop, you should recheck tires for complete deflation before disassembling the wheel and breaking the bead of the tire. Breaking the bead means separating the bead of the tire from the wheel flange. When a tire has been completely deflated and set aside to await the bead-breaking operation, the valve core should be removed and a deflated tire tag installed on the valve stem. The tire tags should be so constructed as not to be installable unless the valve core has been removed. Refer to figure 7-5.

BREAKING THE BEAD.—The use of proper equipment for breaking the bead of the tire away from the wheel flange will save materials and man-hours. Aircraft tires, inner tubes, and wheels can be damaged beyond repair by improper mounting and dismounting equipment and procedures. Always refer to the applicable manufacturer's operating manual prior to using this equipment. The equipment shown in figure 7-18 is recommended in NAVAIR 04-10-506. Other commercially available or locally fabricated equipment that uses either a hydraulically actuated cylinder or a mechanically actuated device may also be used, provided the equipment will not damage the tires or wheels. The bead-breaking equipment shown in figure 7-18 is available in two models. The Lee-I model is

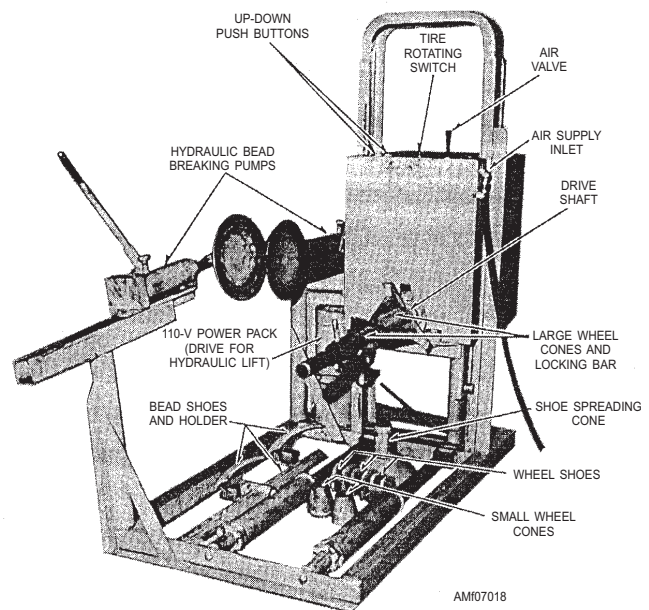

Figure 7-18.—Aircraft wheel holder and tire bead-breaking machine.

designed for use at shore-based facilities. The Lee-IX model is an explosionproof version of the Lee-I, and is intended for shipboard use.

An example of the steps used for bead breaking using the Lee-I equipment follows:

1. Ensure the tire is completely deflated.
2. Determine the type and size of the wheel to be dismounted, and assemble the proper parts on the drive shaft.
3. Push the outer centering rollers toward the front of the machine, and roll the wheel (positioned with the locking side facing outward for demountable flange wheels) on the outer centering rollers. You should use the up and down push buttons to raise or lower the drive shaft to the proper height for the wheel being dismounted. Push the wheel onto the drive shaft. If an open-rimmed tire assembly is being dismounted, omit step 4 and proceed to step 5.
4. Insert the locking bar and turn it about 90 degrees counterclockwise. Mount the wheel cone on the locking bar and insert the locking pin.
5. Push the air valve switch to the right. This will clamp the wheel on the drive shaft.
6. Use the UP push button to raise the center of the wheel to line up with the center of the bead-breaking disc.

7. Rotate the tire by pushing the tire rotating toggle to the right. Position the front bead-breaking disc against the outside bead of the wheel flange. You should adjust the position of the hydraulic pump assembly by loosening the position lockpin and sliding the pump to the proper position. After turning the pump release valve clockwise as far as it will go, apply hydraulic pressure against the bead by pumping the handle, as shown in figure 7-19. Use the guide handle to properly position the disc. Push the bead back far enough to allow the removal of the locking or loose flange.

8. Remove the locking and loose flange. You should use the bead shoes to hold the bead back while you are removing the locking. See figure 7-20. Release and retract the front bead-breaking disc by turning the release valve counterclockwise.

9. Repeat the bead-breaking operation against the rear surface of the tire with the rear bead-breaking assembly.

10. After the beads are broken on divided (split) wheels, remove the nuts and bolts while the wheel assembly is mounted on the machine.

DISMOUNTING DIVIDED (SPLIT) WHEELS.—The tire bead should be broken away from the wheel and the nuts and bolts removed

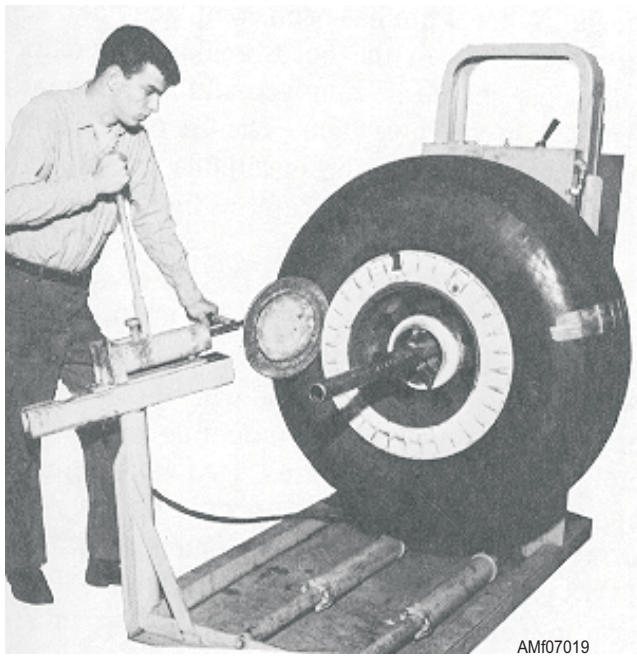

Figure 7-19.—Using bead-breaking pump.

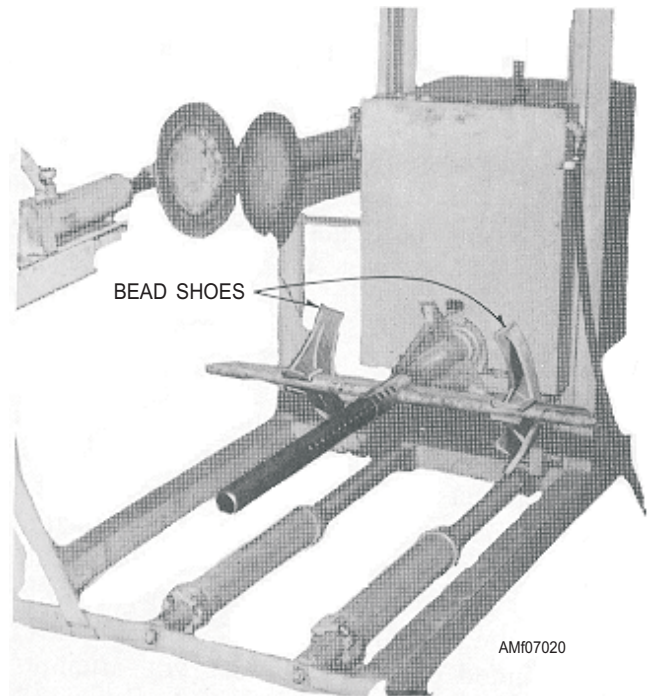

Figure 7-20.—Shaft arranged to hold tire bead while removing locking.

according to the bead-breaking procedure. If the tire has a tube, remove the hex nut and push the valve away from the seated position. This will prevent damage to the inner tube valve attachment when you break the tire bead loose. Then, remove the wheel assembly from the tire. If the tire is tubeless, remove the wheel seal carefully from the wheel half and place it on a clean surface. Wheel seals in good condition may be reused if replacement seals are not available. If the tire has a tube, remove it. Inner tubes can be reused if they are in good condition and less than 5 years old.

DISMOUNTING DEMOUNTABLE FLANGE WHEELS.—The tire bead should be broken away from the wheel according to the bead-breaking procedure. If the tire has a tube, you should remove the hex nut and push the valve away from the seated position. This will prevent damage to the inner tube valve attachment when you break the bead.

If you have trouble removing the flange while the wheel is mounted on the bead-breaking machine, remove the tire from the machine. Lay the tire and wheel assembly flat with the demountable flange side up. Drive the demountable flange down by tapping it with a rubber, plastic, or rawhide-faced mallet. This should enable you to remove the locking ring.

CAUTION

You must take extreme care when you break the beads loose and remove the lockring on some demountable flange wheels. The toe of the demountable flange may extend very close to the tube valve stem. Excessive travel of the demountable flange or of the tire bead may damage the rubber base of the inner tube valve.

If the tire is tubeless, remove the wheel seal carefully and place it on a clean surface. Wheel seals in satisfactory condition may be reused if replacement seals are not available. Turn the tire and wheel assembly over and lift the wheel out of the tire. Remember to keep the wheel flange and locking ring together as a unit to avoid mismatch during remounting.

Mounting

Prior to mounting a tire on a wheel, you should inspect the tire and ensure the inside of the tire is free of foreign materials. The inner tube must be inspected for bead chafing, thinning, folding, surface checking, heat damage, fabric liner separation, valve pad separation, damaged valves, leaks, and other signs of deterioration.

MOUNTING DIVIDED (SPLIT) WHEELS.—

All wheel halves should be matched by year and month of manufacture as closely as possible. Wheel assemblies received from overhaul that have matching overhaul dates on both rims should be maintained as matched assemblies. In the event a wheel assembly is received or made up of wheel halves having different overhaul dates, the wheel overhaul should be based upon the earlier date. All wheels should fit together easily.

When you mount a tube tire, dust the tube with talcum powder and insert it in the tire. The tire should be positioned so the balance marker on the tube is located next to the balance marker on the tire.

NOTE: The balance marker on an inner tube is a stripe of contrasting colors approximately 1/2 inch wide and 2 inches long. It is located on the valve side of the tube. The balance mark on a tire is a red dot approximately one-half inch in diameter. It is located on the sidewall near the bead.

You should inflate the tube until it is round, and then place the valve-hole half of the wheel into position in the tire. Push the valve stem through the hole.

Finally, insert the other half of the wheel and align the bolt holes.

NOTE: All bolts must be magnetic particle inspected to ensure they are not defective.

Install four bolts, nuts, and washers 90 degrees apart. Start the bolts by hand, and tighten them evenly until the wheel halves seat. Install the remaining bolts, nuts, and washers. Tighten the bolts in a crisscross order to prevent distorting the wheel or damaging the inserts. A pneumatic-powered impact wrench may be used, provided the torque obtained does not exceed 25 percent of the specified final torque required for the wheel. Use a calibrated torque wrench, and tighten each bolt in increments of 25 percent of the specified torque value in a crisscross order until the total torque value required for each bolt in the wheel has been reached.

NOTE: When lubtork is specified on the wheel half, coat all the treads and bearing surfaces of the bolt heads with MIL-T-5544 antiseize compound. Lubtork must not be used on magnesium wheels. For magnesium wheels, you should use MIL-G-21164 lubricant. All excessive lubricant should be removed.

Before mounting tubeless tires, check the tire sidewall for the word *tubeless*. Tires without this marking should be treated as tube tires. When you mount tubeless tires, install the valve stem (valve core removed) in the wheel assembly. Removing the valve core prevents unseating of the wheel seal by the pressure built up when the tire is installed. Insert one wheel half in the tire, and position the tire so the balance marker on the tire is located at the valve stem. Install the wheel seal. Be sure the outer wheel half has been lubricated with a light coat of MIL-G-4343 lubricant. Install the other wheel half and align the bolt holes. Install the bolts, washers, and nuts in the same manner used for the wheel assembly containing inner tubes.

MOUNTING DEMOUNTABLE FLANGE WHEELS.—

When you mount a tube tire on a demountable flange wheel, the inner tube should be prepared and inserted in the tire in the same manner used on a split or divided wheel. The wheel is then positioned on a flat surface with the fixed flange down. Push the tire on the wheel assembly as far as it will go, and guide the valve stem into the valve slot with the fingers. Install the demountable flange on the wheel. Secure the locking ring according to the assembly instructions required by the applicable wheel manual.

When you mount a tubeless tire on a demountable flange wheel, install the valve stem (valve core

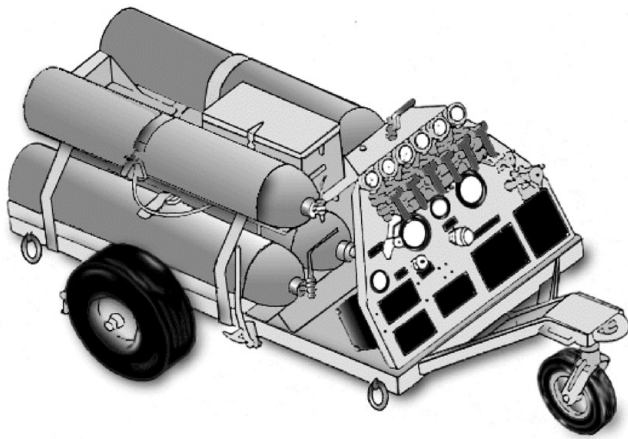

NAN-2 NITROGEN SERVICING UNIT

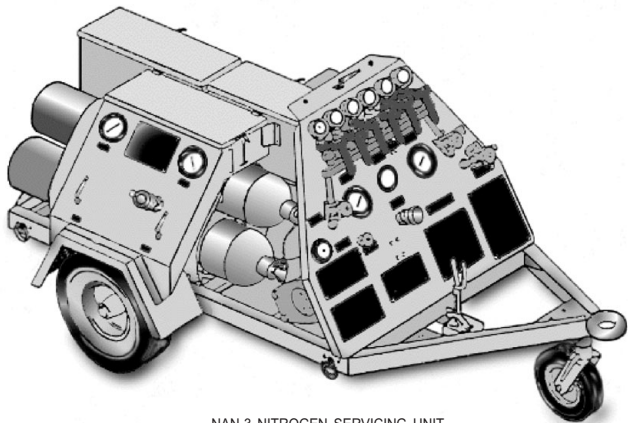

NAN-3 NITROGEN SERVICING UNIT

AM107021

Figure 7-21.—Nitrogen servicing units.

removed) in the wheel assembly. Removing the valve core prevents unseating the wheel seal by the pressure built up when the tire is installed. The wheel seal should be lubricated with the same lubricant and in the same manner as previously mentioned for split or divided

wheel assemblies using tubeless tires. Install the wheel seal on the flange. Secure the locking ring according to the assembly instructions required by the applicable wheel manual.

Tire Inflating

According to Federal Specification BB-N-411, water-pumped nitrogen should be used to inflate tires. When nitrogen is not available, dry, oil-free air may be used. Nitrogen is provided in a number of mobile carts. The NAN-2 and NAN-3 carts are shown in figure 7-21. Tire shops are generally equipped with a bulkhead nitrogen outlet.

All high-pressure inflation sources should be equipped with a regulator that limits the line pressure to the remote inflator assembly. The regulator should be set to provide a controlled inlet pressure to the inflator. It should not exceed the required tire inflation pressure by more than 50 percent or 600 psi, whichever is less.

The tire inflator assembly kit is an excellent maintenance device if it is used and cared for according to the NAVAIR 17-1-123 manual. See figure 7-22. This manual includes the operation instructions, maintenance instructions, and illustrated parts breakdown for the remote inflator assembly and dual chucks stem gauge.

The tire inflator assembly kit consists of a remote controller, a low- and high-pressure gauging element, and a 10-foot service hose. The remote inflator assembly should be calibrated upon initial receipt, before being placed in service, and every 6 months thereafter. The unit is equipped with a built-in relief

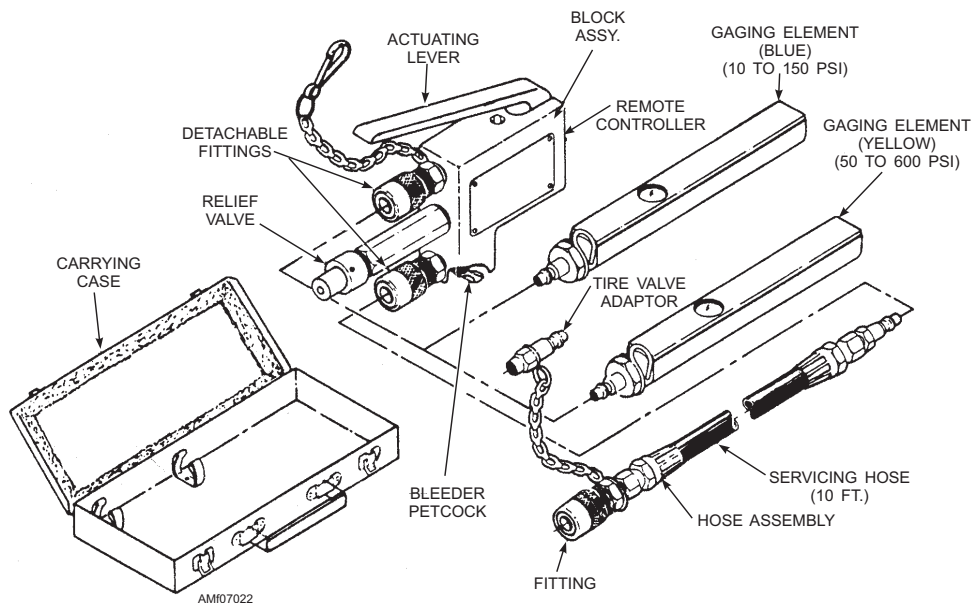

AM107022

Figure 7-22.—Tire inflator assembly kit.

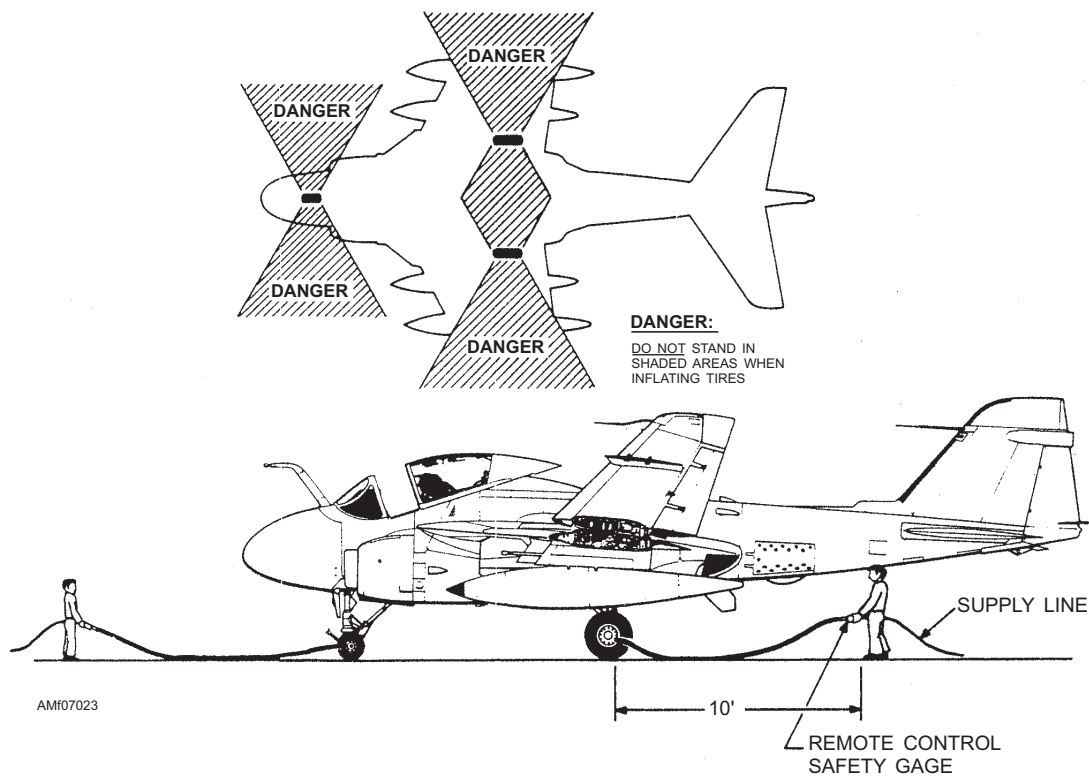

Figure 7-23.—Operator position while servicing tire.

valve to prevent overpressurization of a tire during inflation. The relief valve should be set at 20 psi above the maximum pressure required. It should also be sealed with a "calibration void if seal broken" decal. The needs of each activity will be different, depending on the type of aircraft supported. For example, an organizational activity with a single type of aircraft will only need a single inflator assembly. An activity with multiple types of aircraft will need an inflator assembly preset for each type of aircraft, based on the required pressure. Intermediate activities (tire shops) should use two gauge elements. One element for use on tires in the range of 10 to 150 psi. Another for a second inflator with relief pressure set at 500 psi for tires ranging from 136 to 480 psi. The inflator assembly controller relief pressure should be clearly labeled or marked. The carrying case should be labeled with the type of aircraft for which the relief valve is set. Figure 7-23 shows the operator's position while servicing tires installed on an aircraft.

After the buildup of a new tire at an AIMD or IMA, it should be placed in a safety cage for inflation. A typical safety cage is shown in figure 7-24. The method of inflation used depends on whether a tube or tubeless tire is being inflated.

To inflate tube tires, you should remove the valve core and place the wheel assembly in the safety cage. Attach a remote tire inflation gauge assembly to the

valve stem. Be sure the inner tube is not being pinched between the tire bead and the wheel flange. On demountable flange wheels, be sure the demountable flange and locking ring are seated properly. Secure the safety cage door and inflate the tire to its maximum operating pressure. This will seat the tire beads against

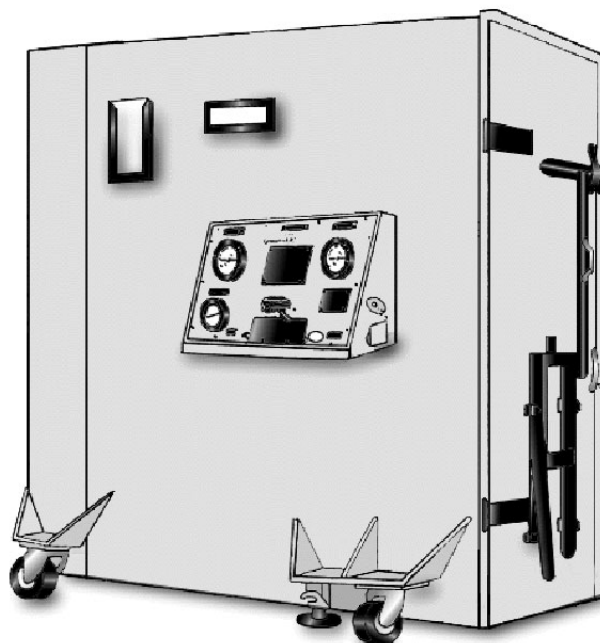

AMF07024

Figure 7-24.—Inflation safety cage with aircraft tire inflator/monitor attached.

the rim flanges. Deflate the tire and install the valve core. Then, reinflate the tire to its maximum operation pressure. You should allow the tire to remain at this pressure for a minimum of 10 minutes. At the end of this 10-minute period, there should be no detectable pressure loss.

NOTE: Install only aircraft tire valve cores, P/N TRC24 or C4, identified by a slot in the head of the pin. See figure 7-25.

If no pressure loss is detected, the tire pressure is reduced to 50 percent of the maximum operating pressure or 100 psi, whichever is less. The tire and wheel assembly is then removed from the safety cage, a valve cap installed, and the assembly stored in a rack, ready for issue.

If there is a significant pressure loss, the tire pressure is reduced to 50 percent of the maximum operating pressure or 100 psi, whichever is less. Then, the assembly is removed from the safety cage and the cause of the leak determined. If a slow leak is detected, the air retention test should be extended to 24 hours. If the leakage exceeds 5 percent, the tire should not be issued until remedial action is taken.

A loss of pressure less than 5 percent may be experienced during the first 24 hours after initial inflation of a new tire. This is attributed to normal tire stretch. The tire pressure should be adjusted

accordingly. Tubeless tires are inflated in the same manner as tube tires except the valve core is not removed.

TIRE RETREADING AND REPAIR

The Navy considers all aircraft tires to be potentially retreadable. Used aircraft tires should not be discarded or scrapped until they have been determined unfit for further use. All tires removed from aircraft should have the injuries marked with a wax crayon. Then, the tire should be turned in to the AIMD or IMA for screening. The AIMD or IMA will determine if the tire is serviceable or non-serviceable and take the necessary action.

Serviceable Tires

Serviceable tires are those judged suitable for continued service use by the tire shop personnel. They should be retained in service until the remaining tread at any spot is one thirty-second of an inch thick or to the limits of the tread wear indicators. Defects permitted are cut limits contained on the tire sidewall or as listed in *Aircraft Tires and Tubes*, NAVAIR 04-10-506. Cuts are permitted in the sidewall provided they do not penetrate to the cord body fabric.

Non-serviceable Tires

Non-serviceable tires may be non-retreadable or retreadable. Non-retreadable tires should be coded "H" (BCM-9) for condemnation and forwarded to the local supply department. The following inspection criteria must be used by the tire shop personnel to determine those tires that are non-retreadable:

- Blowouts
- Punctures extending through the entire carcass that measure more than one-fourth inch in diameter or length on the outside and more than one-eighth inch in diameter or length on the inside
- Loose, frayed, or broken cords evident on the inner tire surface
- Cord body fabric damage, visible to the naked eye without the use of mechanical devices

NOTE: Exposure of cords on fabric-reinforced tread tires (imprinted on the tire sidewall) is permissible.

- Kinked, broken, or exposed wire beads

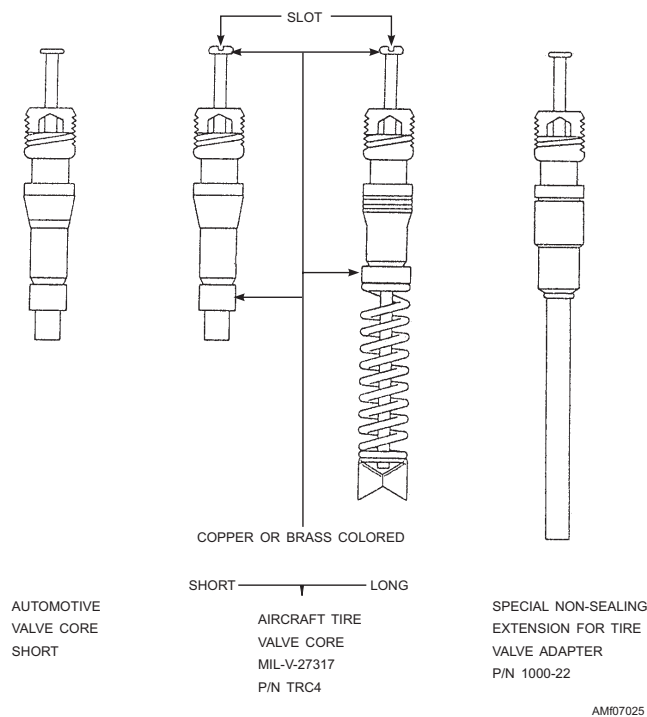

Figure 7-25.—Valve core identification.

- Tread separation and bulges that exceed 1 inch
- Tires saturated with rubber deteriorating liquids
- Tires exposed to excessive heat

All tires removed from service, which are not condemned, are potentially rebuildable and should be condition coded "F" (BCM-1) and returned to the supply department for retreading. The number of retreads a carcass may receive will be based solely on carcass integrity as determined by the inspection criteria.

TIRE PREVENTIVE MAINTENANCE

Debris on runways and in parking areas causes tire failures, and results in many tires being removed long before they reach full service life. It is important that those areas be kept clean at all times.

When you ground handle an aircraft, do not pivot with one wheel locked or turn sharply at slow speeds. This not only scuffs off the tread, but also causes internal separation of the cords. Always be sure the aircraft is moving before you attempt a turn. This allows the tire to roll instead of scrape.

You should make every effort to prevent oil, grease, hydraulic fluid, or other harmful materials from coming in contact with the tires. When there is a chance that harmful materials may come in contact with the tires during maintenance, they should be protected by covers. To clean tires that have come in contact with oil, grease, or other harmful material, you should use a brush or cloth saturated in a soap and water solution. Rinse well with tap water.

Uneven Tread Wear

If a tire shows signs of uneven or excessive tread wear, the cause should be investigated and the



Figure 7-26.—Rapid tread wear caused by underinflation.



Figure 7-27.—Rapid tread wear caused by overinflation.

condition remedied before the tire is ruined. Some of the common causes of uneven tread wear are underinflation, overinflation, misalignment, and incorrect balance.

UNDERINFLATION.—Underinflation causes the tire to wear rapidly and unevenly at the outer edges of the tread, as shown in figure 7-26. An underinflated tire develops higher temperatures during use than a properly inflated tire. This can result in tread separation or blowout failure.

OVERINFLATION.—Overinflation reduces the tread contact area, causing the tire to wear faster in the center, as shown in figure 7-27. Overinflation increases the possibility of damage to the cord on impact with foreign objects and arresting cables on the runway or flight deck.

MISALIGNMENT.—Figure 7-28 shows rapid and uneven tire wear caused by incorrect camber or toe-in. The wheel alignment should be corrected to avoid further wear and mechanical problems.

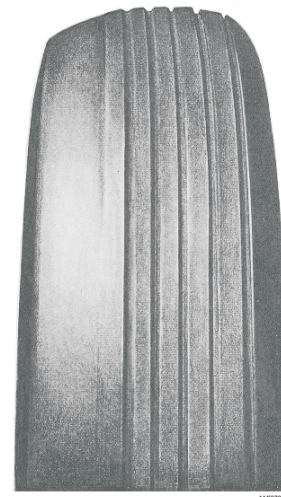

Figure 7-28.—Rapid tread wear caused by misalignment.

BALANCE.—Correct balance of the tire, tube, and wheel assembly is important. A heavy spot on an aircraft tire causes that spot to always hit the ground first upon landing. This results in excessive wear at the one spot and an early failure at that part of the tire. A severe case of imbalance may cause excessive vibration during takeoff and landing. This makes handling of the aircraft difficult.

Nylon Flat Spotting

If the aircraft stands in one place under a heavy static load for several days, local stretching may cause an out-of-round condition with a resultant thumping during takeoff and landing.

Dual Installations

On dual-wheel installations, tires should be matched according to the dimensions indicated in table 7-1. Tires vary somewhat in size between manufacturers and can vary a great deal after being used. When two tires are not matched, the larger one supports most or all of the load. Since one tire is not designed to carry this increase in load, a failure may result.

Table 7-1.—Tolerances for Diameters of Paired Tires in Dual Installations

Tire Outside Diameter	Maximum Difference In Outside Diameters
Less than 18 inches	1/8 inch
18 to 24 inches	1/4 inch
25 to 32 inches	5/16 inch
33 to 40 inches	3/8 inch
41 to 48 inches	7/16 inch
49 to 55 inches	1/2 inch
56 to 65 inches	9/16 inch
More than 65 inches	5/8 inch

- Q7-17. What part of the tire gives it tensil strength, resistance to internal pressure, and the ability to maintain its shape?*
- Q7-18. What is the most common tread pattern design used on naval aircraft tires?*
- Q7-19. What term refers to a tire's maximum recommended load for a specific type of service?*
- Q7-20. What is the final nondestructive inspection method used for rebuilt tires?*

- Q7-21. If only one numerical designation is used for a tire, what does it refer to?*
- Q7-22. Where is tire-marking information recorded after a tire change?*
- Q7-23. What does R or TR followed by a number on a tire indicate?*
- Q7-24. All tubeless tires and tires with tubes must be suitably vented to release trapped air if they exceed what psi?*
- Q7-25. How are vent holes marked on tubeless tires?*
- Q7-26. What type of damage is caused by sunlight?*
- Q7-27. A tire should be sent to AIMD or IMA if it shows repeated pressure loss that exceeds what percent of the correct operating pressure?*
- Q7-28. Tire slippage marks are what color?*
- Q7-29. How often should slippage marks on aircraft tires be inspected?*
- Q7-30. What explosionproof, bead-breaking equipment is intended for shipboard use?*
- Q7-31. An aircraft inner tube can still be reused up to what maximum age?*
- Q7-32. How are tubeless tires identified?*
- Q7-33. During tire inflation, the setting on the pressure regulator should NEVER exceed what psi?*
- Q7-34. How often is a remote tire inflator assembly required to be calibrated?*
- Q7-35. After inflating an aircraft tire, what is the minimum time you must wait before checking for a detectable pressure loss?*
- Q7-36. A nonserviceable tire that has been "H" coded is considered to be in what condition?*
- Q7-37. What solution should be used to clean tires that have come into contact with grease, oil, and other harmful materials?*
- Q7-38. What will cause a tire to wear faster in the center?*

AIRCRAFT TUBES

LEARNING OBJECTIVES: Recognize the procedures for identifying aircraft tire tubes. Identify the procedures for storing aircraft

tubes. Identify the procedures for the inspection of aircraft tire tubes.

The purpose of the inner tube is to hold the air in the tire. Tubes are identified by the type and size of the tire in which they are to be used.

IDENTIFICATION

Tubes are designated for the tires in which they are to be used. For example, a type I tube is designed for use in a type I tire. The size of the tube is the size of the tire in which it is designed to fit.

Inner tubes required to operate at 100 psi or higher inflation pressures are usually reinforced with a ply of nylon cord fabric around the inside circumference. The reinforcement extends a minimum of one-half inch beyond that portion of the tube that contacts the rim.

Type III and type VII inner tubes have radial vent ridges molded on the surface, as shown in figure 7-29. These vent ridges relieve air trapped between the casings and the inner tube during inflation.

Inner tube valves are designed to fit specific wheel rims. However, when you are servicing the tire, a special valve-bending configuration or extension to provide access to the valve stem may be required.

TUBE STORAGE

Tubes should be stored under the same conditions as new tires. New tubes should be stored in their original containers. Used tubes should be partially inflated (to avoid creasing), dusted with talc (to prevent sticking), and stored in the same manner as tires. Each tube should be plainly marked to identify contents, size,

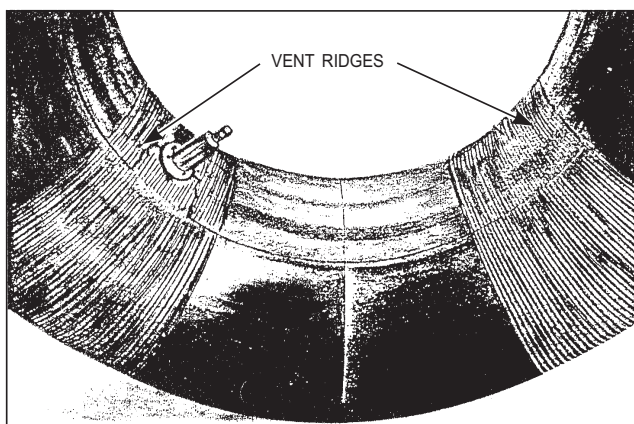

Figure 7-29.—Inner tube vent ridges.

type, cure date, and stock number. Under no circumstances should inner tubes be hung over nails or hooks.

INSPECTION

Inner tubes should be inspected and classified as serviceable or nonserviceable. Usually, leaks due to punctures, breaks in the tire, and cuts can be detected by the eye. Small leaks may require a soapy water check. Complete submersion in water is the best way to locate small leaks. If the tube is too large to be submerged, spread soapy water over the entire surface and examine it carefully for air bubbles. The valve stem and valve base should be swished around to break any temporary seals. The tube should be checked for bent or broken valve stems and stems with damaged threads.

Serviceable Tubes

Inner tubes should be classified as serviceable if they are found to be free of leaks and other defects when they are inflated with the minimum amount of nitrogen required to round out the tube and water checked.

Nonserviceable Tubes

Nonserviceable tubes may be repairable or nonrepairable. Nonserviceable tubes with the following defects should be classified as repairable:

- Bent, chafed, or damaged metal valve threads
- Replaceable leaking valve cores

Nonserviceable tubes with the following defects should be classified as nonrepairable:

- Any tear, cut, or puncture that completely penetrates the tube
- Fabric-reinforced tubes with blisters greater than one-half inch in diameter in the reinforced area
- Chafed or pinched areas caused by beads or tire breaks
- Valve stems pulled out of fabric-base tubes
- Deterioration or thinning due to brake heat
- Folds or creases
- Severe surface cracking
- No balance marker

- Q7-39. A type III tire is used with what type of tube?*
- Q7-40. Radial vent ridges molded on the surface are found on what type (s) of inner tubes?*
- Q7-41. To prevent sticking, used tubes should be dusted with what substance?*
- Q7-42. Small leaks in tubes can be detected by using what type of check?*
- Q7-43. If an inner tube is free of leaks and defects, it is considered to be in what category?*
- Q7-44. A nonserviceable inner tube that has bent, chafed, or damaged metal valve threads should be classified as what type of tube?*

CHAPTER 8

BASIC HYDRAULICS

INTRODUCTION

All modern naval aircraft contain hydraulic systems that operate various mechanisms. The number of hydraulically operated units depends upon the model of aircraft. The average operational aircraft has about a dozen hydraulically operated units. Aircraft hydraulic systems are designed to produce and maintain a given pressure over the entire range of required fluid flow rates. The pressure used in most Navy high-performance aircraft is 3,000 psi. The primary use of hydraulic fluids in aircraft hydraulic systems is to transmit power, but hydraulic systems perform other functions. Hydraulic fluid acts as a lubricant to reduce friction and wear. Hydraulic fluid serves as a coolant to maintain operating temperatures within limits of critical sealant materials, and it serves as a corrosion and rust inhibitor. Critical functions of hydraulic systems may be impaired if the hydraulic system fluid is allowed to become contaminated beyond acceptable limits.

Hydraulic fluid contamination is defined *as any foreign material or substance whose presence in the fluid is capable of adversely affecting the system performance or reliability*. Contamination is always present to some degree, even in new, unused fluid. Contamination must be below the level that adversely affects system operation. Hydraulic contamination control consists of requirements, techniques, and practices that minimize and control fluid contamination. Remember the proverb, "An ounce of prevention is worth a pound of cure."

HYDRAULIC FLUIDS

LEARNING OBJECTIVE: Identify the types of hydraulic fluid used in naval aircraft and support equipment and their characteristics.

Aircraft hydraulic systems are capable of reliable unattended operation for long periods of time, but some periodic service is generally required. Such service will be either fluid servicing or air bleeding. Hydraulic fluids MIL-H-5606, MIL-H-83282, and MIL-H-81019 are used in automatic pilots, shock absorbers, brakes, control mechanisms, servo control systems, and other

hydraulic systems using seal materials compatible with petroleum-based fluids. The primary use for hydraulic fluid MIL-H-46170 is as a preservative fluid for hydraulic systems and components storage.

MIL-H-83282

MIL-H-83282 is the principal hydraulic fluid used in military aircraft. MIL-H-83282 replaces MIL-H-5606. It is dyed red so it can be distinguished from incompatible fluids. MIL-H-83282 has a synthetic hydrocarbon base and contains additives to provide the required viscosity and antiwear characteristics, which inhibit oxidation and corrosion. It is used in hydraulic systems having a temperature range of -40°F to +275°F. Flash point, fire point, and spontaneous ignition temperature of MIL-H-83282, which is fire resistant, exceeds that of MIL-H-5606 by more than 200°F. The fluid extinguishes itself when the external source of flame or heat is removed. Hydraulic fluid MIL-H-83282 is compatible with all materials used in systems presently using MIL-H-5606. It may be combined with MIL-H-5606 with no adverse effect other than a reduction of its fire-resistant properties. **MIL-H-83282 is now required in the main systems of all fleet aircraft previously using MIL-H-5606.** MIL-H-83282 is not used in some viscous dampers due to its low-temperature characteristics.

MIL-H-5606

MIL-H-5606 was the principal hydraulic fluid used in naval aircraft before MIL-H-83282 was introduced. MIL-H-5606 consists of petroleum products with additive materials to improve viscosity (temperature characteristics), inhibit oxidation, and act as an antiwear agent. The oxidation inhibitor was included to reduce the amount of oxidation that occurs in petroleum-based fluids when they are subjected to high pressure and high temperature, and to minimize corrosion of metal parts due to oxidation and resulting acids. The temperature range of MIL-H-5606 is between -65°F to +275°F. It is dyed red so it can be distinguished from incompatible fluids. **Hydraulic fluid MIL-H-5606 is compatible with hydraulic fluid MIL-H-46170.**

MIL-H-81019

MIL-H-81019 is an ultra-low temperature hydraulic fluid. It is used in aircraft when extremely low surrounding temperatures are expected. MIL-H-81019 consists of petroleum products with additive materials to improve its viscosity (temperature characteristics), increase its resistance to oxidation, inhibit corrosion, and act as an antiwear agent. It is dyed red so it can be distinguished from other incompatible hydraulic fluids. **In extreme emergencies, it is interchangeable with hydraulic fluid MIL-H-5606 and MIL-H-83282.** MIL-H-81019 is designed to operate in hydraulic systems having a temperature range between -90°F to +120°F.

MIL-H-46170

The primary use of MIL-H-46170 is as a preservative fluid for hydraulic systems and components storage. Components serviced with this preservation fluid should be drip drained and filled with MIL-H-83282 prior to being installed. This fluid should not be mixed under any other condition. It is also used as a testing medium in stationary test stands that have a temperature range between -40°F to +275°F. It is dyed red so it can be distinguished from incompatible fluids.

NOTE: When mixing or combining hydraulic fluids, the aircraft logbook or S/E logs and records need to be annotated when this is done.

- Q8-1. *What is the primary use for MIL-H-46170 hydraulic fluid?*
- Q8-2. *What is the temperature range of MIL-H-83282 hydraulic fluid?*
- Q8-3. *Where do you annotate that you have mixed hydraulic fluid in a particular aircraft?*

HYDRAULIC CONTAMINATION CONTROL PROGRAM

LEARNING OBJECTIVE: Recognize the purpose and procedures of the Navy's Hydraulic Contamination Control Program.

Hydraulic contamination in Navy and Marine Corps aircraft and related support equipment (SE) is a major cause of hydraulic system and component failure. Every technician who performs hydraulic maintenance should be aware of the causes and effects of hydraulic contamination. You should follow correct

practices and procedures to prevent contamination. Supervisory and quality assurance personnel must know and ensure compliance with accepted standards. Each maintenance level needs to accept their applicable responsibility. Supervisory personnel at each level of maintenance should indoctrinate and train personnel and implement procedures that apply to that level of maintenance.

The Hydraulic Contamination Control Program is defined in the *Naval Aviation Maintenance Program (NAMF)*, OPNAVINST 4790.2 (series). Within the scope of this program, training must be consistent with the objectives of an effective aircraft hydraulic system contamination control program. At all maintenance levels, personnel must be trained in matters pertaining to hydraulic systems contamination control using Hydraulic Contamination Control Training Device 4B38A or Videotape Number 802577DN. The Hydraulic Contamination Control Program requires you to follow the correct procedures during fluid sampling, maintenance procedures, and practices.

FLUID SAMPLING

Contamination measurement standards and acceptability limits define and control hydraulic contamination levels. The maximum acceptable hydraulic fluid particulate level is Navy Standard Class 5 for naval aircraft and Navy Standard Class 3 for related SE. The contamination level of a particular system is determined by analysis of a fluid sample drawn from the system. Analysis is accomplished at all levels of maintenance through the use of Contamination Analysis Kit 57L414. Hydraulic system fluid sampling is accomplished on a periodic basis according to the applicable maintenance instruction manual (MIM), maintenance requirement cards (MRC), and rework specification. Figure 8-1 shows the requirements for periodic fluid surveillance.

You should perform analysis of hydraulic systems if extensive maintenance and/or crash/battle damage occurs. You should perform the analysis when a metal-generating component fails, an erratic flight control function or a hydraulic pressure drop is noted, or there are repeated and/or extensive system malfunctions. Analysis is performed when there is a loss of system fluid, or when the system is subjected to excessive temperature. Analysis is also performed when an aircraft is removed from storage in accordance with NAVAIR 15-05-500. You should perform analysis of the hydraulic system anytime hydraulic contamination is suspected.

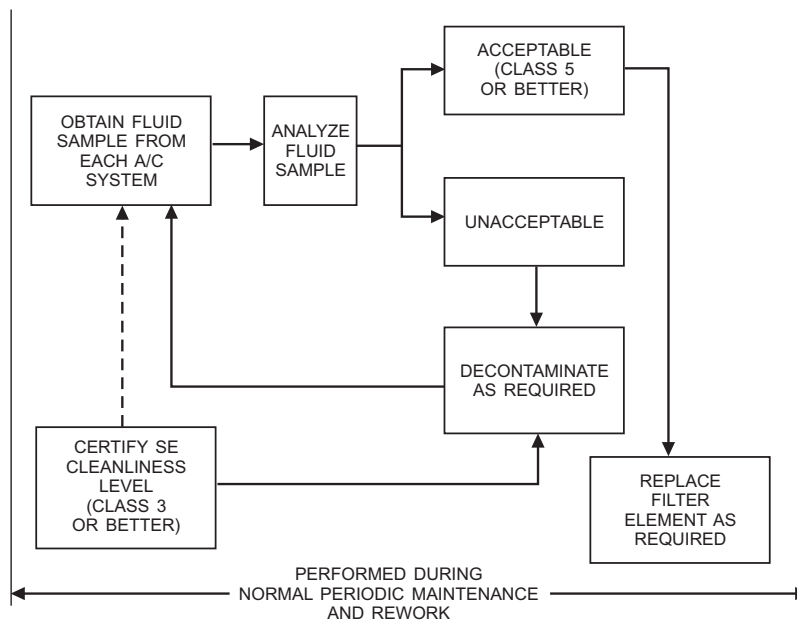

AMF08001

Figure 8-1.—Periodic fluid surveillance requirements.

MAINTENANCE PROCEDURES

The general contamination control procedures and testing of hydraulic systems, subsystems, components, and fluids are requirements for each maintenance level. Hydraulic fluid contamination controls ensure the cleanliness and purity of fluid in the hydraulic system. Fluid sampling and analysis is performed periodically. Checks are made sufficiently before the scheduled aircraft induction date so that if fluid decontamination is required, it may be accomplished at that time. The condition of the fluid depends, to a large degree, on the condition of the components in the system. If a system requires frequent component replacement and servicing, the condition of the fluid deteriorates proportionately.

Replacement of aircraft hydraulic system filter elements takes place on a scheduled or conditional basis, depending upon the requirements of the specific system. A differential pressure flow check and bubble point test are performed to properly evaluate the condition of a cleanable filter element. These two checks are done to verify that the element is good before it is installed in a system or component. Many filter elements look identical, but not all of them are compatible with flow requirements of the system.

If the hydraulic system fluid is lost to the point that the hydraulic pumps run dry or cavitate, you should change the defective pumps, check filter elements, and decontaminate the system as required. Check the applicable MIM for corrective action to be taken regarding decontamination of the system. If this action

is not taken, the complete system could be contaminated. Hydraulic systems and components are serviced by using approved fluid dispensing equipment only. Unfiltered hydraulic fluid should NEVER be introduced into systems or components.

All portable hydraulic test stands must receive the required periodic maintenance checks. Make certain that each unit is approved, and the applicable MIM is readily accessible and up to date. When the portable hydraulic test stand is not in use, it should be protected against contaminants such as dust and water. You should ensure that correct hoses are used on each stand, and that they are approved for the type of fluid being used. Properly cap hoses when they are not being used. Hoses must be serialized and must remain with the equipment. Make sure the hoses are coiled, kept free of kinks, and properly stowed. Make sure they are in satisfactory condition and are checked periodically. Replace any hose that exhibits fluid seepage from the outer cover or separation between the inner tube and the outer cover. Portable hydraulic test stands that show indications of contamination or that have loaded (clogged) filters are removed from service immediately and returned to the supporting activity for maintenance.

Use only approved lubricants for O-ring seals; incorrect lubricants will contaminate a system. Many lubricants look alike, but few are compatible with hydraulic fluids. The only approved O-ring seal lubricants are hydraulic fluid MIL-H-5606, hydraulic fluid MIL-H-83282, hydraulic fluid MIL-H-46170, or a thin film of grease, MIL-G-81322.

MAINTENANCE PRACTICES

Good housekeeping and maintenance practices help eliminate problems caused by contamination. Be careful if you work on a hydraulic system in the open, especially under adverse weather conditions. Use caution if you work on hydraulic equipment near grinding, blasting, machining, or other contaminant-generating operations. Often, you cannot see harmful grit. Do not break into hydraulic systems unless absolutely necessary (this includes cannibalization). Use the proper tools for the job. Use only authorized hydraulic fluid, O-rings, lubricants, or filter elements. When dispensing hydraulic fluid, make sure you use an authorized fluid service unit. Check to make sure that the hydraulic fluid can is clean before it is installed. After use, dispose of all empty hydraulic fluid cans and used hydraulic fluid in accordance with Navy and local hazardous material (HAZMAT) instructions. Keep hydraulic fluid in a closed container at all times.

Keep portable hydraulic test stand reservoirs above three-quarters full. Seal all hydraulic lines, tubing, hoses, fittings, and components with approved metal closures. You should not use plastic plugs or caps because they are possible contamination sources. Install quick-disconnect dust covers. Store unused caps and plugs in a clean container.

Remove exterior contaminants by using approved wiping cloths. Lint-free wiping cloths should be used on surfaces along the fluid path. If possible, have the replacement component on hand for immediate installation upon removal of defective component. Replace filters immediately after removal. If possible, fill the filter bowl with proper hydraulic fluid before you install it to minimize the induction of air into the system. Do not reset differential pressure indicators if the associated filter element is loaded and in need of replacement. When cleanable filter elements are removed from hydraulic systems, put them in individual polyethylene bags and forward them to the intermediate- or depot-level maintenance activity for cleaning. **Do not clean** cleanable filter elements by washing them in a container and blowing them out with shop air. Cleanable filter elements must be cleaned and tested according to applicable procedures before they are reused. Clean all connections, interconnect the pressure and return lines of the stand, and circulate the hydraulic fluid through the test stand filters before connecting portable hydraulic test stands to aircraft.

NOTE: Do not use chlorinated solvents to clean connectors. Use dry-cleaning solvent MIL-PRF-680 or filtered hydraulic fluid.

Store O-rings, tubing hoses, fittings, and components in clean packaging. Do not open or puncture individual packages of O-rings or backup rings until just before you use them. Do not use *used or unidentifiable* O-rings. Replace seals or backup rings with new items when they have been disturbed. Use the correct O-ring installation tool when you install O-rings over threaded fittings to prevent threads from damaging the O-ring.

If packages of tubing, hoses, fittings, or components are opened when received or found opened, decontaminate their contents. Decontaminate the system if you suspect it is contaminated (including water). Keep the working area where hydraulic components are repaired, serviced, or stored clean and free from moisture, metal chips, and other contaminants. Perform required periodic checks on equipment you use to service hydraulic systems. Use hydraulic fluid MIL-H-46170 in stationary hydraulic test stands.

- Q8-4. *What is the maximum acceptable Navy Standard Class hydraulic fluid particulate for naval aircraft?*
- Q8-5. *What manuals specify how aircraft hydraulic fluid sampling is conducted?*
- Q8-6. *What are the four approved lubricants to be used on O-ring seals?*

TYPES OF CONTAMINATION

LEARNING OBJECTIVE: Identify the types and sources of hydraulic contamination found in naval aircraft.

There are many different forms of contamination, including liquids, gasses, and solid matter of various composition, size, and shape. Normally, contamination in an operating hydraulic system originates at several different sources. The rate of its introduction depends upon many factors directly related to wear and chemical reaction. Contamination removal can reverse this trend. Production of contaminants in the hydraulic system increases with the number of system components. The rate of contamination from external sources is not readily predictable. A hydraulic system can be seriously contaminated by poor maintenance practices that lead to introducing large amounts of external contaminants. Poorly maintained SE is another source of contamination.

Contaminants in hydraulic fluids are classified as particulate and fluid contamination. They may be further classified according to their type, such as organic, metallic solids, nonmetallic solids, foreign fluids, air, and water.

PARTICULATE CONTAMINATION

The type of contamination most often found in aircraft hydraulic systems consists of solid matter. This type of contamination is known as particulate contamination.

The size of particulate matter in hydraulic fluid is measured in microns (millionths of a meter). The largest dimensions (points on the outside of the particle) of the particle are measured when determining its size. The relative size of particles, measured in microns, is shown in figure 8-2. Table 8-1 shows the various classes of particulate contamination levels.

Contamination of hydraulic fluid with particulate matter is a principal cause of wear in hydraulic pumps, actuators, valves, and servo valves. Spool-type electro

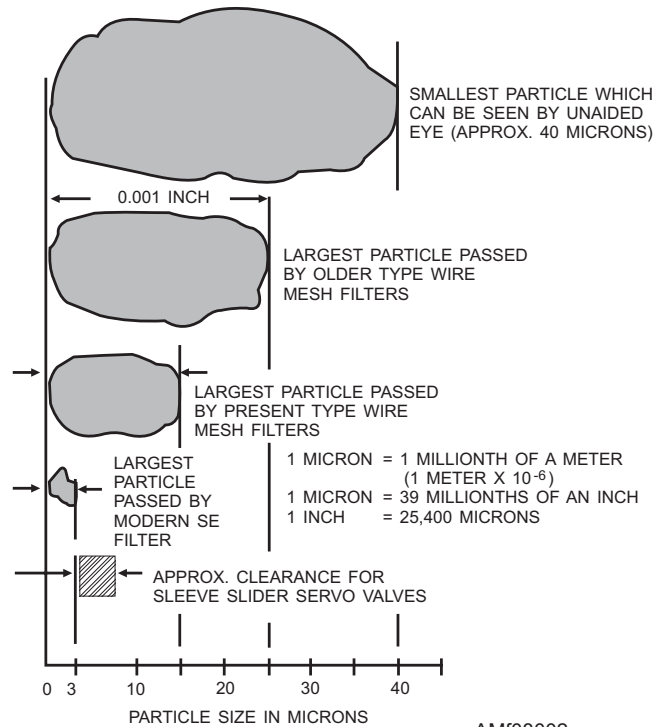

Figure 8-2.—Graphic comparison of particle sizes.

Table 8-1.—Particle Contamination Level By Class

MICRON SIZE RANGE	PARTICLE CONTAMINATION LEVEL—BY CLASS						
	Acceptable						Unacceptable
	0	1	2	3	4	5	6
5-10	2,700	4,600	9,700	24,000	32,000	87,000	128,000
10-25	670	1,340	2,680	5,360	10,700	21,400	42,000
25-50	93	210	380	780	1,510	3,130	6,500
50-100	16	28	56	110	225	430	1,000
Over 100	1	3	5	11	21	41	92
Total	3,480	6,181	12,821	30,261	44,456	112,001	177,592
NOTES							
<ol style="list-style-type: none"> The class of contamination is based upon the total number of particles in any size range per 100 ml of hydraulic fluid. Exceeding the allowable particle count in any one or more size ranges requires that the next higher class level be assigned. Class 5 is the maximum acceptable contamination level for hydraulic systems in naval aircraft. Fluid delivered by SE to equipment under test or being serviced must be Class 3, or cleaner. The Class 5 level of acceptability shall be met at the inspection interval specified for the equipment under test. 							

hydraulic valves have been used in particle contamination experiments. The valves are easy to control and respond rapidly to repositioning. In these experiments, the valves were operated with both ultra clean and contaminated hydraulic fluids. The experiments proved that wear is accelerated by even small amounts of contamination. Contamination increases the rate of erosion of the sharp spool edges and general deterioration of the spool surfaces. Because of the extremely close fit of spools in servo valve housings, the valves are particularly susceptible to damage or erratic operation when operated with contaminated hydraulic fluid.

Organic Contamination

Organic solids or semisolids are one of the particulate contaminants found in hydraulic systems. They are produced by wear, oxidation, or polymerization (a chemical reaction). Organic solid contaminants found in the systems include minute particles of O-rings, seals, gaskets, and hoses. These contaminants are produced by wear or chemical reaction.

Oxidation of hydraulic fluids increases with pressure and temperature. Antioxidants are blended into hydraulic fluids to minimize such oxidation. Oxidation products appear as organic acids, asphaltics, gums, and varnishes. These products combine with particles in the hydraulic fluid to form sludge. Some oxidation products are oil soluble and cause an increase in hydraulic fluid viscosity, while other oxidation products are not oil soluble and form sediment. Oil oxidation products are not abrasive. These products cause system degradation because the sludge or varnish like materials collect at close-fitting, moving parts, such as the spool and sleeve on servo valves. Collection of oxidation products at these points causes sluggish valve response.

Metallic Solid Contamination

Metallic solid contaminants are usually found in hydraulic systems. The size of the contaminants will range from microscopic particles to those you can see with the naked eye. These particles are the result of the wearing and scoring of bare metal parts and plating materials, such as silver and chromium. Wear products and other foreign metal particles, such as steel, aluminum, and copper, act as metallic catalysts in the formation of oxidation products. Fine metallic particles enter hydraulic fluid from within the system. Although

most of the metals used for parts fabrication and plating are found in hydraulic fluid, the major metallic materials found are ferrous, aluminum, and chromium particles.

Hydraulic pumps usually contribute the most contamination to the system because of their high-speed, internal movement. Other hydraulic systems produce hydraulic fluid contamination due to body wear and chipping.

Hydraulic actuators and valves are affected by contamination. Large metallic or hard nonmetallic particles collect at the seal areas. These particles may groove the inside wall of the actuator body due to a scraping action. Smaller particles act as abrasives between the seals and the actuator body, causing wear and scoring. Eventually, the fluid leaks and the seals fail because the seal extrudes into the enlarged gap between the piston head and the bore of the actuator body. Once wear begins, it increases at a faster rate because wear particles add to the abrasive material. In a similar manner, metallic or nonmetallic parts may lodge in the poppets and poppet-seat portions of valves and cause system malfunction by holding valves open.

Inorganic Solid Contamination

The inorganic solid contaminant group includes dust, paint particles, dirt, and silicates. These and other materials are often drawn into hydraulic systems from external sources. The wet piston shaft of a hydraulic actuator may draw some of these foreign materials into the cylinder past the wiper and dynamic seals. The contaminant materials are then dispersed in the hydraulic fluid. Also, contaminants may enter the hydraulic fluid during maintenance when tubing, hoses, fittings, and components are disconnected or replaced. To avoid these problems, all exposed fluid ports should be sealed with approved protective closures.

Glass particles from glass bead peening and blasting are another contaminant. Glass particles are particularly undesirable because glass abrades synthetic rubber seals and the very fine surfaces of critical moving parts.

FLUID CONTAMINATION

Hydraulic fluid can be contaminated by air, water, solvents, and foreign fluids. These contaminants and their effects are discussed in the following text.

Air Contamination

Hydraulic fluids are adversely affected by dissolved, entrained, or free air. Air may be introduced through improper maintenance or as a result of system design. Air is sometimes introduced when changing filters. You can minimize this kind of contamination by putting hydraulic fluid into the filter holder before reassembling the filter. By doing this, you have introduced less air into the hydraulic system. The presence of air in a hydraulic system causes *spongy* response during system operation. Air causes cavitation and erodes hydraulic components. Air also contributes to the corrosion of hydraulic components.

Water Contamination

Water is a serious contaminant of hydraulic systems. Corrective maintenance actions must be taken to remove all free or emulsified water from hydraulic systems. Hydraulic fluids and hydraulic system components are adversely affected by dissolved, emulsified, or free water. Water may be induced through the failure of a component, seal, line or fitting, poor or improper maintenance practices, and servicing. Water may also be condensed from air entering vented systems.

The presence of water in hydraulic systems can result in the formation of undesired oxidation products, and corrosion of metallic surfaces will occur. These oxidation products will also cause hydraulic seals to deteriorate and fail, resulting in leaks. If the water in the system results in the formation of ice, it will reduce fluid flow and impede the operation of valves, actuators, or other moving parts within the system. This is particularly true of water located in static circuits or system extremities and subject to high-altitude, low-temperature conditions. Microorganisms will grow and spread in hydraulic fluid contaminated with water. These microorganisms will clog filters and reduce system performance.

Solvent Contamination

Solvent contamination is a special form of foreign-fluid contamination. The original contaminating substance is a chlorinated solvent introduced by improper maintenance practices. It is extremely difficult to stop this kind of contamination once it occurs. This type of contamination can be prevented by using the right cleaning agents when performing hydraulic system maintenance. Chlorinated solvents, when allowed to combine with minute

amounts of water, hydrolyze to form hydrochloric acids. These acids attack internal metallic surfaces in the system, particularly those that are ferrous, and produce a severe rust like corrosion that is virtually impossible to arrest. Extensive component overhaul and system decontamination are generally required to restore the system to an operational status.

Foreign Fluids Contamination

Contamination of hydraulic fluid occurs when the wrong fluids get into the system, such as oil, engine fuel, or incorrect hydraulic fluids. Hydraulic oil coolers, which are used in some aircraft, leak and cause contamination of hydraulic fluids. If you think that contamination has occurred, the system must be checked by chemically analyzing fluid samples. This analysis is conducted by the cognizant engineering activity, which verifies and identifies the contaminant and directs decontamination procedures.

The effects of foreign fluid contamination depend upon the nature of the contaminant. The compatibility of the construction materials and the system hydraulic fluid with the foreign fluid must be considered when dealing with contamination. Other effects of this type of contamination are hydraulic fluid reaction with water and changes in flammability and viscosity characteristics. The effects of contamination may be mild or severe, depending upon the contaminant, how much is in the system, and how long it has been in the system.

- Q8-7. *What type of contamination is most often found in aircraft hydraulic systems?*
- Q8-8. *What unit of measurement is used for particulate matter?*
- Q8-9. *Oxidation of hydraulic fluid can produce what type of contaminants?*
- Q8-10. *Most metallic contamination in a hydraulic system is produced by what component?*
- Q8-11. *The presence of air in a hydraulic system has what effect?*

SAMPLING POINTS

LEARNING OBJECTIVES: Identify the procedures for sampling hydraulic fluid. Identify the sampling point requirements.

A fluid sampling point is a physical point in a hydraulic system from which small amounts of hydraulic fluid are drawn to analyze it for con-

tamination. Sampling points include air bleed valves, reservoir drain valves, quick-disconnect fittings, removable line connections, and special valves installed for this specific purpose.

Hydraulic fluid sampling points for most naval aircraft are designated in the applicable MIM. Two major factors determine if a sampling point is adequate—its mechanical feature and its location in the system. To determine the contamination level, a single fluid sample is required. This sample must be representative of the working fluid in the system, and it should be a "worst case" indication of the system particulate level. The worst case requirement is necessary because the particulate level in an operating system is not constant throughout the system. Instead, particulate levels differ because of the effects of components (such as filters) on circulating particulates.

The mechanical features of a prospective sampling point are evaluated on the basis of accessibility and ease of operation. The sampling point should not distort the particulate level of the sampled fluid either by acting as a filter or by introducing external or self-generated contaminants. The latter point is particularly critical. You can minimize the introduction of external or self-generated contaminants before collecting a sample by cleaning the external parts of the valve or fitting and by dumping a small amount of the initial fluid flow.

Consideration must also be given to removal of any static fluid normally entrapped between the actual sampling point and the main body of the fluid to be sampled. To do this, you dump an initial quantity of the sampled fluid. Problems may be encountered where a long line is involved, as in certain reservoir drain lines. You should take the fluid sample from a main system return line, pump suction line, or system reservoir. Also, take the sample upstream of any return or suction line filters that may be present. Do not take reservoir samples in a system that has a makeup reservoir, or if the reservoir is bypassed during SE-powered operation. A makeup reservoir is a configuration in which all of the system return line fluid does not pass through the reservoir. Fluid exchange in the reservoir is limited, and results only from the changes in fluid volume that occur elsewhere in the system.

You should be able to use the sampling point after an aircraft flight, without requiring the use of external SE. Taking a sample with the aircraft engines turning is satisfactory, provided no personnel hazards are involved. You should be able to use the sampling point

when the system is being powered by external SE, or immediately after such an operation.

The sampling point should be next, or reasonably close, to the main body or stream of fluid being sampled. A minimum amount of static fluid is acceptable; however, purge it when you start the sample flow. Do not take a sample from a point located in an area of high sedimentation. If you cannot avoid doing this, make sure sedimentation effects are minimized by discarding an initial quantity of the sample fluid drawn. Ideally, sample fluid should be obtained from turbulent high-flow areas.

When you take a sample at the sampling point, do not introduce significant external contaminants into the fluid collected. If you preclean the external parts of the valve or fitting and self-flush the valve or fitting before the sample is taken, the background level attributable to the sample point itself should not exceed 10 percent of the normally observed particulate level. The internal porting of the sampling point should not impede the passage of hard particulate matter up to 500 microns in diameter. The sampling point should be accessible and convenient. There must be sufficient clearance beneath the valve or fitting to position the sample collection bottle. Under normal system operating pressure, the sample fluid flow rate should be between 100 and 1,000 milliliters per minute (approximately 3 to 30 fluid ounces). The flow rate should be manageable, and the time required to collect the required sample should not be excessive. The mechanical integrity of the sampling valve or fitting should not degrade because of repeated use. When not in use, it is mechanically secured in the closed position.

Q8-12. What two factors determine if a sampling point is adequate?

Q8-13. The internal porting of the sample point should not impede the passage of particulate matter up to what size?

ANALYSIS METHODS

LEARNING OBJECTIVE: Recognize the analysis methods used to identify and measure fluid contamination.

Contamination analysis is used to determine the particulate level of a hydraulic system and the presence of free water or other foreign substances. The methods used to identify and measure contamination are patch testing, electronic particle count analysis, and halogen testing.



AM108003

Figure 8-3.—P/N57L414 contamination analysis kit.

PATCH TESTING

Patch testing is the primary contamination measurement method used at all levels of maintenance. The P/N57L414 contamination analysis kit (fig. 8-3) is used to perform patch testing. In the patch test method, a fluid sample of known volume is filtered through a filter membrane of known porosity. When the fluid passes through the filter, all particulate matter in excess of a size determined by the filter characteristics is retained on the surface of the membrane. The retention of particulate matter causes the membrane to discolor proportionally to the particulate level of the fluid sample. Free water will appear either as droplets during the fluid sample processing or as a stain on the test filter.

The typical color of contamination in any given system is usually uniform. The degree of filter

membrane discoloration correlates to a level of particulate contamination. By visually comparing the test filter with contamination standards that represent known contamination levels, the contaminant level of the system can be determined.

Accurate determination of hydraulic contaminant levels requires proper sampling techniques, using equipment and materials that are known to be clean. If you allow any foreign matter to contaminate the sample fluid or testing equipment, the results will be wrong.

The operational procedures discussed in the following paragraphs are general in nature. For specific information on the use of contamination analysis kits, you should refer to NAVAIR 01-1A-17 and NAVAIR 17-15E-52. Table 8-2 lists the materials required to perform the analysis.

Table 8-2.—Materials Required for Contamination Analysis

Material	Specification/P/N
Dry Cleaning Solvent	MIL-PRF-680, Type II
Wiping Cloths, disposable	
Can, Metal, 1 gallon	
Can, Safety, 5 gallon	RR-S-30
Kit, Hydraulic Fluid Contamination Analysis	P/N 57L414

Preparation

The components of the contamination analysis kit are shown in figure 8-4. Look at this figure as you read about the procedure you should follow to prepare hydraulic fluid for contamination analysis.

The Millex point-of-use filter unit consists of two threaded half-sections and an internal support screen. Use forceps to place one 25-mm solvent filter on the gridded plastic surface of the filter holder.

NOTE: Packaged filter membranes are separated by blue separator discs. Remove separators before installing solvent filter in the filter holder.

Position the perforated support screen on top of the solvent filter to provide support for both sides of the solvent filter. Reassemble the two halves of the filter holder finger tight. Fill the wash bottle (with short spout) with an approved solvent. Dry-cleaning solvent, MIL-PRF-680, is the preferred solvent. However, when using this solvent, sufficient drying time must be allowed.

WARNING

MIL-PRF-680 must be used only in well-ventilated areas, and you should avoid inhalation of vapors. MIL-PRF-680 is combustible, and should be kept away from open flames. You should wear rubber gloves and chemical or splashproof goggles. You should also avoid skin contact with MIL-PRF-680. Failure to observe proper safety precautions could result in personal injury or death to personnel. Consult the local safety office regarding respiratory protection.

Fill the wash bottle (with long spout) with dry-cleaning solvent MIL-PRF-680 to flush sampling points. Replace their screw caps. Attach the filter holder to the wash bottle with the short spout. Make sure the tip of the wash bottle is not damaged by forcing the filter holder on too tightly. If damaged, the other wash bottle may be modified by carefully cutting off the tip so that the filter holder will fit. The damaged wash bottle may then be used for flushing fittings and sampling points.

Clean the required number of sample bottles before use by rinsing and flushing them with filtered solvent. Fill the bottle to be cleaned approximately half full. Replace the cap on the opening, shake the sample bottle several times, remove the cap, and dump the contents.

Repeat this operation three or more times to remove residual hydraulic fluid. When the bottle is considered clean, flush down the external threads of the sample bottle and the internal threads of the bottle cap with filtered solvent. Replace the cap on the bottle.

Sample Taking

Samples taken from aircraft hydraulic systems and SE should be representative of the fluid in the system under test. Aircraft samples should be taken immediately after flight. If postflight samples cannot be obtained, the system is cycled according to directions in the applicable aircraft MIM or MRC before drawing a sample. Before sampling SE hydraulic systems, recirculate the fluid for a minimum of 5 minutes at full flow rate or for a proportionately longer time at a lower flow rate. Remove external contaminants from the sampling point by flushing it with solvent and wiping the sampling point with clean, disposable wiping cloths.

When the sampling point is visibly free of external contaminants, subject it to a final solvent flush. Sampling points not adequately cleaned before use may produce test results that needlessly cause the rejection of the system under test. Begin the flow of fluid to be sampled, by appropriate means, allowing an initial quantity to flow into a waste receptacle. This procedure serves to flush away any contaminant in the sampling line and any contaminants generated by mechanical operation. Without interrupting the flow of fluid, take the required sample by placing a clean sample bottle under the fluid stream. You should take two samples at this time. In the event the first sample is rejected, you will have another sample readily available. End the flow of sample fluid after the sample bottles are full, and it is removed from the stream. Install the caps on the bottle, and put a tag or label on the bottles that identifies the aircraft or equipment sampled and the specific sampling point that was used.

Sample aircraft filter assemblies by removing the filter bowl and transferring the fluid contents of both the bowl and the element to a clean sample bottle. The amount of fluid obtained varies, depending on the type of filter assembly.

Sample Processing

Before the sample is processed, the fluid to be tested is examined visually for evidence of possible free water. Water can be found in hydraulic fluid samples as droplets that usually settle to the bottom of the sample



SOLVENT
FILTERS,
25mm



MILLEX
POINT-OF-USE
FILTER UNIT

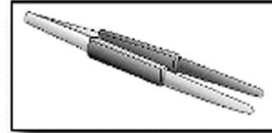

FORCEPS



WASH
BOTTLE

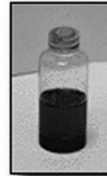

SAMPLE
BOTTLE



FUNNEL



HOLDER
SUPPORT



VACUUM
FLASK

— FILTER HOLDER ASSEMBLY —

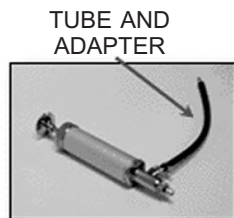

TUBE AND
ADAPTER

SYRINGE

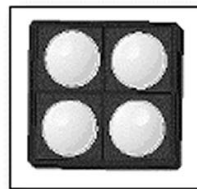

TEST FILTERS
47 mm

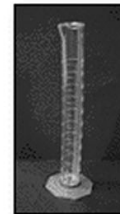

GRADUATE

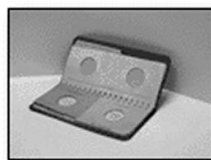

CONTAMINATION
STANDARDS

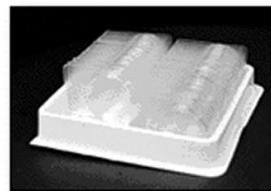

PETRI-SLIDES

AMf08004

Figure 8-4.—Contamination analysis kit components.

bottle. Allowing the fluid sample to remain motionless for 10 minutes or longer may make it easier to see visible droplets, if water is present. If fluid samples are hazy or pink, water may be present. Another identical sample bottle filled with a standard of unused fluid can be used for comparison. If water is observed, take another sample from the system to verify the indication before rejecting the system under test.

Before you can process a sample, get the equipment ready. Remove the filter holder assembly from its storage position in the kit. The funnel and holder support are assembled and stored in an inverted position in the vacuum flask. To prepare the funnel and holder support for use, remove them from the vacuum flask, invert them, and reinstall them in the vacuum flask. If it is difficult to remove the holder support from the vacuum flask, insert the back end of forceps into the slot (present on some holder supports) and pry the holder support from the vacuum flask.

You should use the tube and adapter to connect the syringe to the small opening located on the side of the holder support. Wash down the inside wall of the funnel with filtered solvent to flush any surface contamination present. Make sure that the holder support screen, now located at bottom of funnel neck, is also cleaned with filtered solvent.

NOTE: Rapid evaporation of the filtered solvent may result in the condensation of atmospheric moisture on the funnel surface. The moisture can cause inaccurate indications of free water in the sample under test. Carefully inspect for condensation on the funnel surface. If condensation is present, move equipment to an air-conditioned workspace.

Remove the funnel from the holder support by rotating the outer knurled ring in a counterclockwise direction until it disengages, and lift it upwards. Use forceps to carefully remove a single 47-mm test filter, and place it on top of the screen of the holder support. Make sure that the blue separator discs are not installed with the test filter. Reinstall the funnel on the holder support, and secure it by rotating the outer knurled ring in a clockwise direction until it is fully seated. Use filtered solvent to repeatedly rinse the inside of the graduate to remove all possible contaminants. Pour out any residual solvent. Measure out approximately 15 milliliters of the filtered solvent, using the cleaned graduate, and pour the solvent into the funnel to "pre-wet" the filter membrane.

Shake the bottle of sample fluid. This action distributes the particulate content. Remove the cap

from the sample bottle and pour exactly 100 milliliters of fluid into the graduate. Discard any remaining fluid. Pour the contents of the graduate into the funnel, on top of the previously introduced filtered solvent. Allow the contents of the graduate to drain completely into the funnel. Use the filtered solvent to wash down the inside surface of the graduate until it contains approximately 100 milliliters of solvent.

Operate the syringe by slowly pumping it, which draws a vacuum, until sustained filtration of the fluid is indicated by a steady drop of the fluid level in the funnel. When the fluid level in the funnel drops enough to allow addition of approximately 50 milliliters of solvent, pour half of the contents of the graduate into the funnel as filtration continues. If necessary, operate the syringe again to maintain sufficient vacuum for filtration. Carefully watch the filtration process in the funnel, and note the decreasing fluid level. When the fluid level drops to the narrow neck of the funnel, pour the remaining contents of the graduate into the funnel.

NOTE: Pour the contents so they flow down the inside of the funnel, making sure that the solvent is not poured directly onto the test filter.

When filtration is complete, inspect the test filter surface. If the central area shows a pinkish color, it indicates that the test filter still has a residue of hydraulic fluid. Direct a stream of filtered solvent against the walls of the funnel until fluid reaches the top of the tapered portion. Operate the syringe again to initiate filtration and allow all of this fluid to pass through the test filter. If free water is indicated, test to see if the water originated from the hydraulic fluid sample and not from the rinsing solvent. Perform an additional analysis, but omit the solvent rinses. Water, if present, will still appear on the surface of the filter membrane, but will now tend to spread out rather than to appear in discrete droplet form. Examine closely.

NOTE: When dry-cleaning solvent is used as the filtered solvent, the filter must be dried thoroughly prior to being placed in petri slide. The solvent or fumes will craze and cloud the polystyrene petri slides.

Test Filter Analysis

After you process the fluid sample, visually compare the test filter or patch with the contamination standards. To determine the particulate contamination level, compare the shade and color of the test patch with the corresponding colors of the contamination standards. If the test patch displays a rust or tan color, use the tan standard patch. If the test patch is gray, use

the gray standard patch. In any case, you should follow the operating instructions contained in the contamination standards. Tan patches occur when rust or iron chlorides are formed in the system, or the system contains abnormal amounts of silica (sand). Gray patches are typical of systems containing normal proportions of common wear materials and external contaminants.

The maximum acceptable particulate level for naval aircraft is Navy Standard Class 5. For related SE, the maximum acceptable particulate level is Navy Standard Class 3. If visible free water is present in either the sample bottle or on the surface of the test filter (at completion of filtration), the system under test is rejected. A stain on the test filter membrane may be an indication of the presence of free water. When a stain is seen on the test filter, obtain a second fluid sample from the system under test and process it so that water content can be confirmed prior to system rejection. Make sure that observed water is not a result of atmospheric condensation during the sampling process.

If the system under test fails to meet the Navy Standard Class 5 particulate requirement or if it exhibits free water, the system must be decontaminated according to the procedures listed in the applicable MIM.

Filter Bowl Contents Analysis

Hydraulic fluid samples obtained from filter bowls and/or elements cannot be used to determine system contamination levels. The following combination of factors makes the filter bowl sample useless when determining the system's level of contamination: sedimentation, functional location, and/or an inability to obtain the required 100 milliliters of fluid. Filter bowl residue analysis may be used to monitor hydraulic system degradation, monitor for suspected impending component failure, or isolate a cause for continued contaminant generation.

Evaluate filter bowl patch residues by following the procedures in applicable manuals. As you gain experience about normal contaminants for specific aircraft systems and hours of operation, you will be able to evaluate filter bowl patch residue. Through experience, analysis of main pressure line and case drain filter bowl residues is useful in verifying failure of the upstream hydraulic pump, as large amounts of metal usually show up in these particular assemblies. Residue in other filter assemblies is affected by so many other components and factors that analysis is

difficult. Filter bowl residues should be analyzed only as a means of identifying or verifying suspected component failure. Examine residue from those filter assemblies directly downstream from the component.

ELECTRONIC PARTICLE COUNT ANALYSIS

Electronic particle counters, such as the HIAC Contamination Test Center, Model C-600-1, or Royco Electronic Particle Counters, are used to determine counts of the number of particles in the various size ranges. The counts obtained are compared with the maximum allowable under Navy Standard Class 5. Counts that exceed the maximum allowable in any size range make the fluid unsuitable for use in Navy aircraft.

The test results obtained by using automatic particle counters and the contamination analysis kit are not always precisely the same. Both are authorized for fleet use, and you may use either one. Automatic particle counters optically sense particles contained in the fluid sample and electronically size and count them. Most fleet equipments are calibrated so that the smallest particle counted has an effective diameter of 5 microns. Particles smaller than 5 microns, although always present, do not affect the particle count. The contamination analysis kit uses a patch-test method in which the fluid is filtered through a test-filter membrane. The sample causes the membrane to discolor proportionally to the particulate level. The test filters used have a filtration rating of 5 microns (absolute). However, they also retain a large percentage of those particles less than 5 microns in size. The contamination standards provided with the contamination analysis kit are representative of test indications that result if the fluid sample has a particle size distribution (number of particles versus size) typical of that found in the average naval aircraft. Samples from aircraft systems having typical particle size distributions will, therefore, show good correlation if tested using both particle count and patch test methods.

Some operating hydraulic systems have peculiar design characteristics, so they produce a particle size distribution different from that found in typical naval aircraft. Fluid samples from these systems generally contain an abnormally large amount of silt like particles smaller than 5 microns in size. Experience has shown that this condition results from inadequate system filtration or from using hydraulic components that have abnormally high wear rates. It is this type of fluid sample that could produce different results when tested, using both particle-counting and patch-test methods.

The difference is caused by the particle counter not counting those particles smaller than 5 microns, while many of them are retained by the patch-test filter membrane, causing it to discolor proportionately. When test results conflict, the equipment tested is considered unacceptable if it fails either test method. The equipment should then be subjected to decontamination.

You need to recognize that the differing test results may indicate system deficiencies and justify a request for an engineering investigation of the equipment. Poor correlation between particle counts and patch tests can result from improper sample-taking procedures, incorrect particle counter calibration, or faulty test procedures. These possibilities must be carefully investigated if a correlation problem is encountered.

HALOGEN TESTING

The halogen leak detector (fig. 8-5) is used to test hydraulic fluid samples for MIL-C-81302A (Freon) or other chlorinated solvents. The detector is a battery-powered, self-contained instrument. The instrument provides an audible indication, varying from a slow ticking sound to a loud squeal, to indicate the level of the vapor concentration.

You can determine the acceptability of unknown hydraulic fluid samples by using the HDL-440 leak detector. To do this, you compare the vapor level of a known hydraulic fluid to that of the unknown hydraulic fluid and determine whether the unknown sample contains more or less than 200 ppm (parts per million) of chlorinated solvents. The calibration standard used in the HDL-440 is hydraulic fluid MIL-H-5606 or MIL-H-83282, which contains a known amount (200 ppm) of MIL-C-81302.

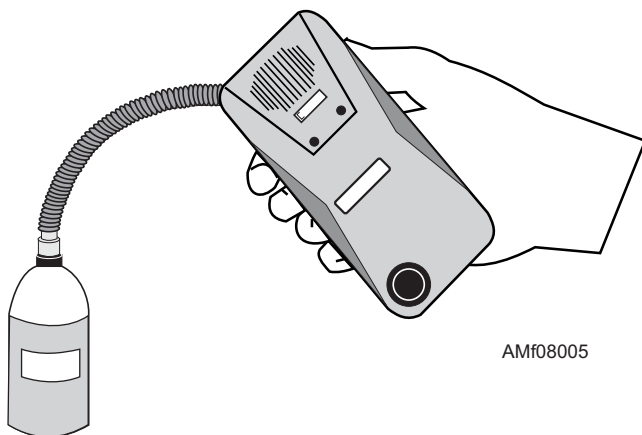

Figure 8-5.—HDL-440 halogen leak detector in operation.

- Q8-14. *What is the primary contamination measurement method used at all levels of maintenance?*
- Q8-15. *When is the best time to take a hydraulic fluid sample?*
- Q8-16. *Before taking a hydraulic fluid sample from a hydraulic test stand, you must recirculate the fluid for how long?*
- Q8-17. *How many samples should you take from each sampling point?*
- Q8-18. *When sampling hydraulic fluid, what size test filter should you use?*

DECONTAMINATION

LEARNING OBJECTIVE: Identify decontamination methods used on naval aircraft and their purpose.

System decontamination is a maintenance operation performed when a system contains fluid that is unacceptable because of contamination. The fluid may be contaminated with foreign matter or it is not considered acceptable for service for some other reason. The purpose of decontamination is to remove foreign matter from the operating fluid or to remove the contaminated fluid itself. Before you can decontaminate an affected system, replace any failed or known contamination-generating components. Other components of the system are not to be disturbed, unless required.

METHODS

There are four basic methods used to decontaminate aircraft hydraulic systems. The methods are recirculation cleaning, flushing, purging, and purifying.

Recirculation Cleaning

Recirculation cleaning is a decontamination process in which the system to be cleaned is powered from a clean external power source. The system is cycled so it produces a maximum interchange of fluid between the powered system and the SE used to power it. When decontaminating a system, the contaminated fluid is circulated through the hydraulic filters in the aircraft system and in the portable hydraulic test stands.

Decontamination that uses the recirculation cleaning method is a filtration process. It can remove

only that foreign matter that is retained by the filter elements normally found in the equipment. A key factor in recirculation cleaning is the use of high-efficiency, 3-micron (absolute) filter elements. Absolute filter elements have no fluid bypass when the filter clogs. The filters have a large dirt-holding capacity in the portable test stands used for this purpose. In a single fluid pass, these filters remove all particulate matter larger than 3 microns, and a high percentage of the other particles down to submicron size. Recirculation cleaning is effective in removing hard particulate matter from hydraulic fluid that is otherwise serviceable. It must be recognized that the filters are not capable of removing water, other foreign fluids, or dissolved solids. Therefore, recirculation cleaning is limited to decontamination of systems found to have a particulate level in excess of Navy Standard Class 5, whose fluid is considered otherwise acceptable. For specific procedures on recirculation cleaning, you should refer to the applicable MIM.

Use recirculation cleaning to remove excessive particulate matter that results from normal component wear, limited component failure, or external sources. Clean the system by powering it with an external portable hydraulic test stand. Operate the aircraft systems so maximum interchange of fluid is produced between the aircraft and the test stand. View A of figure 8-6 shows a flow diagram for recirculation cleaning.

Test stands used for recirculation cleaning must be equipped with 3-micron (absolute) filtration. Before connecting the test stand to the aircraft, the stand itself must be recirculation cleaned and deaerated, and its contamination level verified to meet the Navy Standard Class 3 cleanliness level. If the system has a makeup reservoir, drain and reservice the system reservoir prior to recirculation cleaning. Makeup reservoirs have a single fluid port similar to an accumulator; therefore, little or no fluid exchange takes place during recirculation cleaning.

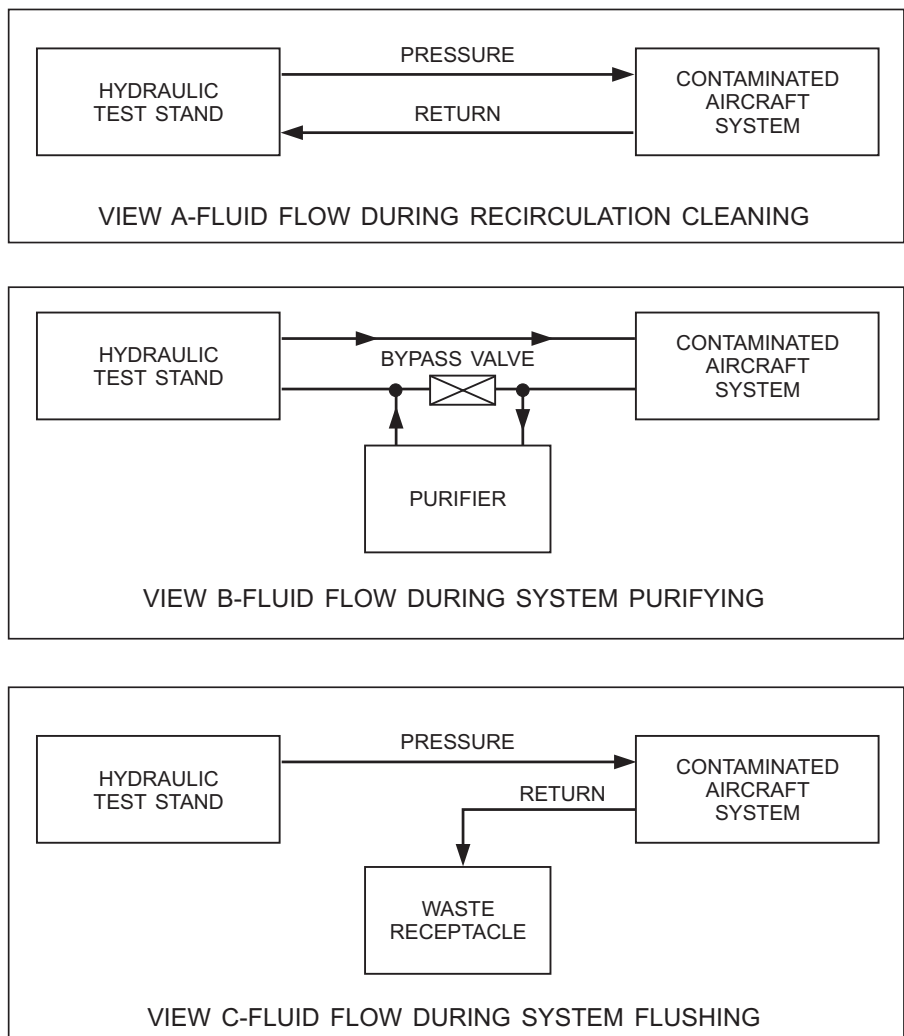

AMF08006

Figure 8-6.—Fluid flow during decontamination.

If contamination is severe, or if aircraft filters are suspected of being loaded or damaged, or if differential pressure indicators have been activated, install new (or cleaned and tested) filter elements in the aircraft before you begin cleaning. Set up and operate the test stand in a manner compatible with the requirements of the specific aircraft and system being powered. Adjust the test stand output pressure and low volume for normal operation of the aircraft system being recirculation cleaned.

Operate all circuits (actuators) on the system undergoing decontamination a minimum of 15 complete cycles, or according to procedures in the specific MIM or MRCs. Give particular emphasis to the operation of large displacement actuators, such as those associated with landing gear and wing fold, when powered by the affected system. Continuously monitor all filter differential pressure indicators, both on the aircraft and on the portable hydraulic test stand, during the cleaning process. Replace any loaded filter elements.

Sample and analyze the system after the cycling of components. If the contaminant level shows improvement but is still unacceptable, repeat the recirculation cleaning process. If no improvement is observed, attempt to determine the source of contamination. System flushing may be required. When successful recirculation cleaning is complete, service the system, as required, to establish the proper reservoir fluid level and to eliminate entrapped air.

Flushing

Flushing is a decontamination method in which contaminated system fluid is removed to the maximum extent practicable and then discarded. It is a draining process that is generally accomplished by powering the aircraft system with a portable hydraulic test stand. See figure 8-6. The contaminated return-line fluid from the aircraft is then allowed to flow overboard into a suitable receptacle for disposal. In effect, filtered fluid from the portable hydraulic test stand is used to displace contaminated fluid in the system and to replenish it with clean serviceable fluid.

The amount of fluid removed and replaced during system flushing varies. It depends upon such factors as the nature of the contaminant, layout of the system, and the ability to produce flow in all affected circuits. Portions of operating systems are often *dead ended*. Fluid found in these portions is static and not affected

by the normal system fluid flow. Remove contaminated fluid in these circuits and associated components by partially disassembling the unit. Drain and totally flush the unit.

Generally, system flushing continues until analysis of the return line fluid from the system being decontaminated indicates that the fluid is acceptable. If there is severe contamination, considerable quantities of hydraulic fluid may be expended, making it important to closely monitor the portable hydraulic test stand reservoir level, and replenish it as required. Flushing effectively decontaminates systems containing water, large amounts of gelatinous-type materials, or fluid that is chemically unacceptable (containing chlorinated or other solvents). This type of fluid contamination or degradation cannot be remedied by conventional filtration. In severe cases of particulate contamination, such as those that result from major component failure, flushing techniques may more easily correct the problem than will recirculation cleaning.

Detailed procedures for flushing hydraulic systems are found in the aircraft MIMs. The basic procedures are discussed in the following text, and will give you some idea of the procedures used when flushing aircraft hydraulic systems. Remember, use the MIM for the specific procedures to use when flushing hydraulic systems. Use flushing to decontaminate systems that cannot be cleaned by recirculation cleaning or purifying. Normally, flushing requires you to remove fluids that are found to be chemically or physically unacceptable, or fluids contaminated with water, other foreign fluids, or particulate matter not readily filterable because of its nature or the quantity involved. Use an external portable hydraulic test stand to power the contaminate system and accomplish flushing. Allow return fluid from the aircraft to flow overboard into a waste container for disposal. Aircraft subsystems should be operated to produce maximum displacement of aircraft fluids by cleaned, filtered fluid from the portable test stand. View B of figure 8-6 shows fluid flow during system flushing.

Test stands used for system flushing must be equipped with 3-micron (absolute) filtration and must have a minimum internal reservoir of 16 gallons. The stand itself should be recirculation cleaned and deaerated before it is connected to the aircraft. Drain, flush, and service the reservoirs or other fluid storage devices in the contaminated system before system flushing. If you know that the contamination originated at an aircraft pump, drain and flush the hoses and lines

directly associated with the pump output. Case drains should be drained and flushed separately.

If the aircraft filters are suspected of being loaded, install new or cleaned and tested filter elements in the aircraft hydraulic filters before flushing. Test stands must be set up and operated in accordance with the requirements of the specific aircraft and the system being flushed. Adjust the test output pressure and the flow volume for normal operation of the aircraft system being flushed. Monitor the reservoir level in the portable test stand continuously during the flushing operation. Use approved fluid-dispensing equipment to replenish the reservoir before the level decreases to the half-full point. Depletion of the SE reservoir fluid may result in cavitation or failure of the test stand pump.

Operate all the circuits (actuators) on the system undergoing decontamination until the amount of fluid collected from the aircraft return line is equivalent to approximately three times the fluid capacity of the affected system. Give particular emphasis to the operation of large displacement actuators, such as those associated with landing gear and wing fold when powered by the affected system. Continuously monitor all the filter differential pressure indicators on the aircraft and in the SE. Replace any loaded filter elements. Sample and analyze the system after cycling of the components. If contaminant level shows improvement but is still unacceptable, continue the flushing operation. If no improvement is observed, try to find the source of contamination and correct it. If extensive system flushing fails to decontaminate the affected system adequately, request assistance from the cognizant engineering activity.

Upon successful completion of system flushing, recirculation clean it for a minimum period to eliminate possible residual debris and to ensure that the system is in acceptable condition. Sample the system after recirculation cleaning to verify that contaminant level is satisfactory. If an unsatisfactory condition is again indicated, repeat the flushing or recirculation cleaning operation as required. Upon successful completion of system decontamination, service the system to establish proper reservoir fluid level and to bleed entrapped air.

Purging

Purging is a decontamination process in which the aircraft hydraulic system is drained to the maximum extent practicable and the removed fluid discarded.

Then, a suitable cleaning agent is introduced into the hydraulic system and circulated as effectively as possible to dislodge or dissolve contaminating substances. The cleaning operation is followed by complete removal of the cleaning agent, and then replace it with new hydraulic fluid. After purging the system, flushing and recirculation cleaning is performed to ensure adequate decontamination. Purging aircraft hydraulic systems is performed only upon recommendation from, and under the direct supervision of, the cognizant engineering activity. The cognizant engineering activity is responsible for selecting the required cleaning agents, providing detailed cleaning procedures, and performing tests upon completion of purging to ensure satisfactory removal of all cleaning agents. Whenever possible, purging operations should be accomplished at a naval aviation depot (NADEP).

NOTE: Organizational and intermediate maintenance activities are not authorized to perform system purging.

Purifying

Purification is the process of removing air, water, solid particles, and chlorinated solvents (MIL-C-81302 and MIL-T-81533) from hydraulic fluids. Contaminated fluid going to the purifier tower is first filtered by a 25-micron (absolute) filter. The vacuum applied to the tower removes air, water, and chlorinated solvents from the contaminated fluid. As fluid comes out of the tower, it is filtered through a 3-micron (absolute) filter to remove solid particles. See figure 8-6. This cycle is repeated until a desired level of cleanliness is attained. For systems contaminated with air, water, and chlorinated solvents MIL-C-81302 and MIL-T-81533, you can use a purifier to clean the aircraft and support equipment (SE) to reduce the consumption of fluid and replace the need for flushing.

SELECTION OF METHOD

The type of contamination present in a system determines the method by which a system is decontaminated. Normally, recirculation cleaning is the most effective decontamination method, considering maintenance man-hours and material requirements. This method should be used whenever possible. However, if a system is contaminated by some substance other than readily filterable particles, it may be necessary to flush the system, or in certain very

extreme cases, to purge it. Refer to table 8-3. The table contains information to help you select an appropriate decontamination method. The table refers to chemical analysis and particle counting, as well as to the normally performed patch testing and visual tests. You may request chemical analysis and actual particle counts of fluid samples from the NADEP materials engineering laboratories. You may use these test results to select a decontamination method.

CONTAMINATION CONTROL SEQUENCE

System decontamination is one operation of a contamination control sequence that includes hydraulic fluid sampling and analysis. Decontamination is performed when the results of sampling and analysis indicate an unacceptable contamination level. Then, additional testing determines when an acceptable level is reached.

There are many operations required during the contamination control sequence, and these operations

interact during the sequence. Figure 8-7 is a basic contamination control sequence chart for aircraft system decontamination. It is a guide for decontaminating all naval aircraft and portable hydraulic test stands. The procedures outlined in the chart reflect basic requirements of periodic maintenance, periodic aircraft rework, and maintenance performed as a result of actual or suspected malfunctions.

Q8-19. An aircraft's hydraulic systems should be operated a minimum of how many complete cycles while undergoing recirculation cleaning?

Q8-20. Hydraulic test stands used for system flushing must be equipped with a 3-micron absolute filters and have an internal reservoir that holds how many gallons?

Q8-21. Whenever possible, purging operations should be accomplished at what activity?

Table 8-3.—Aircraft Decontamination Requirements

TEST METHOD	ABNORMAL INDICATION	**DECONTAMINATION METHOD REQUIRED
Visual Inspection	Free Water—standing or droplets	Flush
	Dissolved Water—pinkish fluid, not clear	Flush
	Gelatinous Substances	Flush
	Visible Gross Particulate Matter	Flush
	Oxidation—dark fluid, not clear	Flush
Patch Test	Excessive Particulate—exceeds Class 5	SE Recirculation
	Water Droplets or Stains	Flush
	Fibers	SE Recirculation
	Gross Particulate Matter—extreme contamination from component failure or external sources	Flush
Particle Count	Excessive Particulate Matter—exceeds Class 5	SE Recirculation
Chemical Analysis (Depot)	Viscosity—out of limit (*) centistokes @ 100°F	Flush
	Flash Point—less than 180°F	Flush
	Water—in excess of (*) ppm	Flush
	Neutralization—in excess of 0.8 mg KOH/g (acid)	Flush
	Chlorinated Solvents—exceeds (*) ppm	Flush
(*) Acceptable limits to be determined by the cognizant engineering activity.		
** Fluid purifiers may be used instead of flushing when purifying equipment is available.		

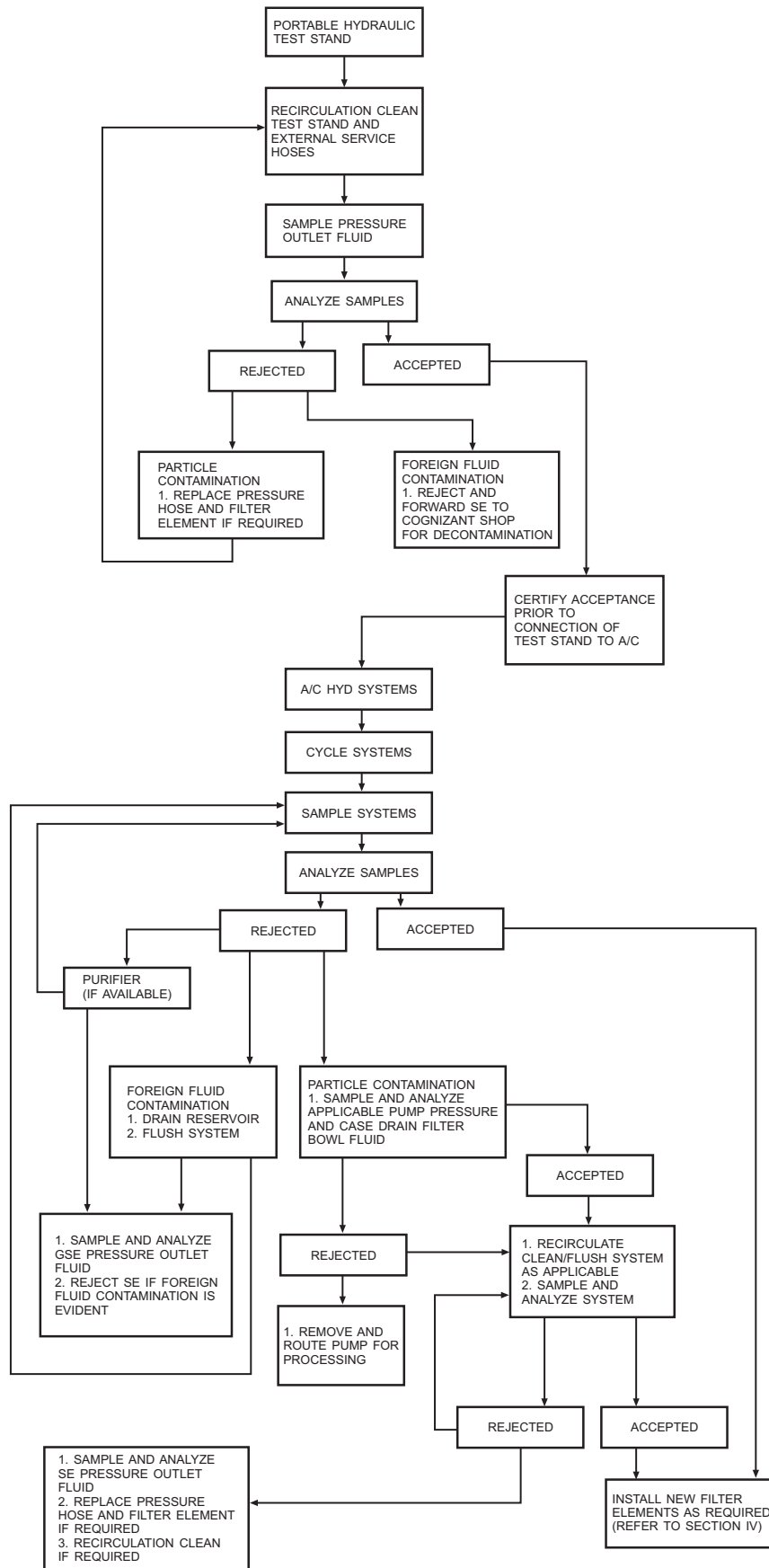

AMf08007

Figure 8-7.—Sequence control chart for aircraft system decontamination.

Q8-22. Considering maintenance man-hours and material requirements, what is the most effective decontamination method?

AIRCRAFT HYDRAULIC HARDWARE AND SEALS

LEARNING OBJECTIVE: Identify the various hydraulic hardware and seals used in naval aircraft.

Hardware, such as the quick-disconnect coupling, and seals and packings are used throughout the aircraft. They are essential for safe and proper operation of aircraft systems. You must be familiar with the various types used on naval aircraft.

QUICK-DISCONNECT COUPLINGS

Quick-disconnect couplings provide a means of quickly disconnecting a line without the loss of hydraulic fluid or entrance of air into the system. Each coupling assembly consists of two halves, held together by a union nut. Each half contains a valve, which is held open when the coupling is connected. This action allows fluid to flow in either direction through the coupling. When the coupling is disconnected, a spring

in each half closes the valve, preventing the loss of fluid and entrance of air.

The union nut has a quick-lead thread that permits connecting or disconnecting the coupling by turning the nut. The amount the nut must be turned varies with different styles of couplings. For one style, a quarter turn of the union nut locks or unlocks the coupling. For another style, a full turn is required. Some couplings require wrench tightening; others are connected and disconnected by hand. Some installations require that the coupling be safetied with safety wire; others do not require any form of safetying. Because of these individual differences, all quick disconnects should be installed in accordance with the instructions in the applicable MIM.

The series 145 and 155 (Aeroquip) couplings make up one type of quick-disconnect coupling found on naval aircraft. These couplings may be identified by the part number (145 or 155) stamped on the face of the union nut.

Each quick-disconnect coupling consists of two halves, referred to as S1 half and S4 half. See figure 8-8. When disconnected, the union nut remains with the S1 half. The S4 half has a mounting flange for attaching to a bulkhead or other structural member of the aircraft.

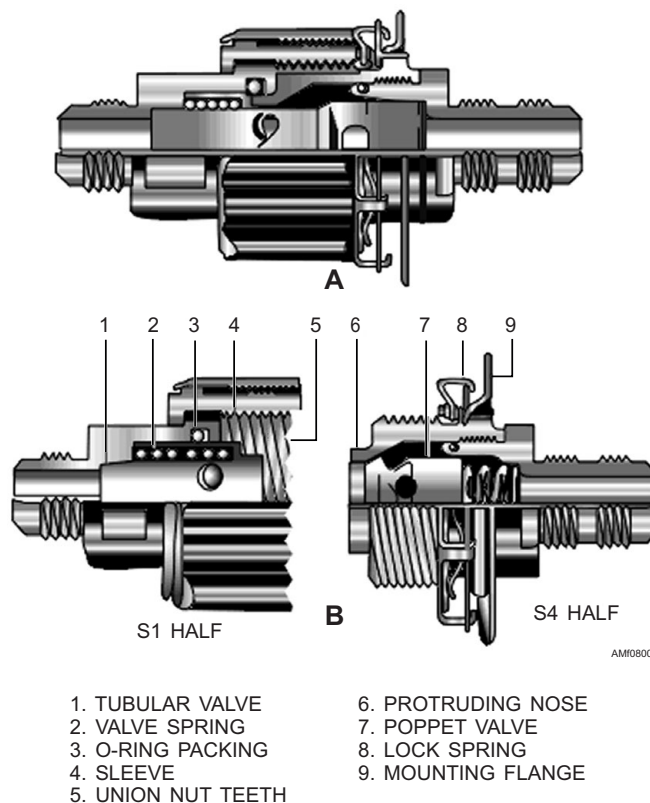

Figure 8-8.—Series 145 and 155 quick-disconnect couplings.

All parts referred to in the following paragraphs are identified in figure 8-8. The two halves of the coupling may be connected by placing the tubular valve (1) within the protruding nose (6) of the mating half, and rotating the union nut in a clockwise direction. The union nut must be rotated until its teeth (5) fully engage the lock spring (8). A properly tightened coupling will have compressed the lock spring until a 1/16-inch minimum gap exists between the inside lip of the spring retainer fingers and the spring plate. Figure 8-9 shows the coupling both properly connected and improperly connected.

The locking action may be followed by referring to figure 8-8. Positive locking is assured by the locking spring (8) with teeth, which engage ratchet teeth on the union nut (5) when the coupling is fully connected. The lock spring automatically disengages when the union nut is unscrewed. An O-ring packing (3) seals against leakage as the coupling halves are joined. Positive opening of the valves occurs as the halves are connected.

When the coupling halves are joined, the protruding nose (6) of the S4 half contacts the sleeve (4)

of the S1 half. Simultaneously, the head of the tubular valve (1) contacts the face of the poppet valve (7), thus preventing air from entering the system.

Tightening the union nut pulls the coupling halves together. This causes the nose of the S4 half to push the sleeve into the S1 half, uncovering the ports to the tubular valve. At the same time, the head of the tubular valve depresses the poppet valve.

When the coupling halves are fully connected, the sleeve and poppet valve have reached the positions shown in the left-hand view of figure 8-9. The nose of the S4 half has engaged the O-ring packing of the S1 half, providing a positive seal.

NOTE: Do not use a wrench to couple or uncouple series 145 or 155 quick disconnects unless a modified union nut is incorporated. Modified union nuts may be identified by the letter *C* preceding the part number on the nut. On these modified union nuts, a wrench may be used to assist in tightening the coupling. Torque values for the various size couplings may be found in the aircraft MIM, and should be strictly complied with in all instances.

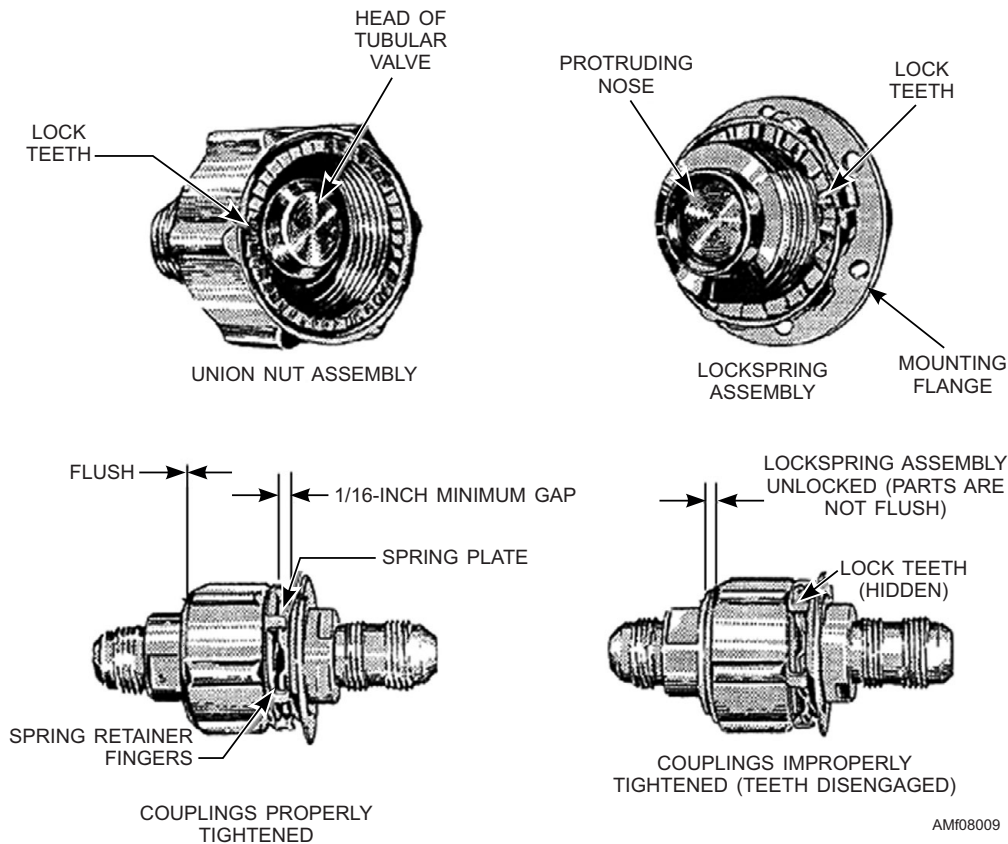

Figure 8-9.—Quick disconnects properly and improperly connected.

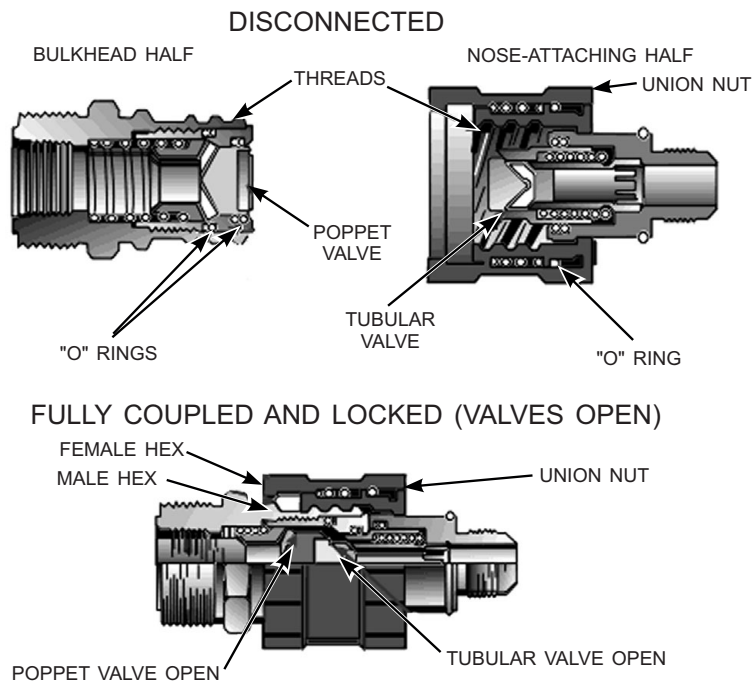

Figure 8-10.—Series 320 (Aeroquip) quick disconnect.

A newer type of quick-disconnect coupling is the series 3200 (Aeroquip). This is an improved version and is simple to operate. This series is designed for use in hydraulic systems up to 3,000-psi operating pressure. Figure 8-10 shows the quick disconnect in both the disconnected and connected positions. To connect, align the tabular valve of the hose-attaching half with the recess in the bulkhead-coupling half. The nut is then brought forward to engage the threads, and rotated in a clockwise direction until the hex nut engages the hex on the coupling body. This may be done in one continuous turn of the union nut, about one-quarter of a revolution. The quick-lead Acme thread allows the coupling to be connected by hand, against pressures up to 300 psi.

The connection may be inspected by three different methods as follows: If the nut can be turned by hand in a clockwise direction, the coupling is not locked. A slight tug on the hose will separate the halves if the couplings are not locked. Inspect the locking male hex on the bulkhead coupling half; if the coupling is not connected, the red male hex of the bulkhead half will be visible.

HYDRAULIC SEALS

Hydraulic seals are used throughout aircraft hydraulic systems to minimize internal and external leakage of hydraulic fluid. They prevent the loss of system pressure. A seal may consist of more than one component, such as an O-ring and a backup ring, or

possibly an O-ring and two backup rings. Hydraulic seals used internally on a sliding or moving assembly are normally called PACKINGS. Hydraulic seals used between nonmoving fittings and bosses are normally called GASKETS. Most packings and gaskets used in naval aircraft are manufactured in the form of O-rings.

An O-ring is circular in shape, and its cross section is small in relation to its diameter. The cross section is truly round and has been molded and trimmed to extremely close tolerances. In some landing gear struts, an elliptical seal is used. The elliptical seal is similar to the O-ring seal except for its cross-sectional shape. As its name implies, its cross section is elliptical in shape. Both the O-ring and elliptical seals are shown in figure 8-11.

Advances in aircraft design have made new O-ring composition necessary to meet changing conditions. Hydraulic O-rings were originally established under AN (Air Force-Navy) specification numbers (6227, 6230, and 6290) for use in fluid at operating

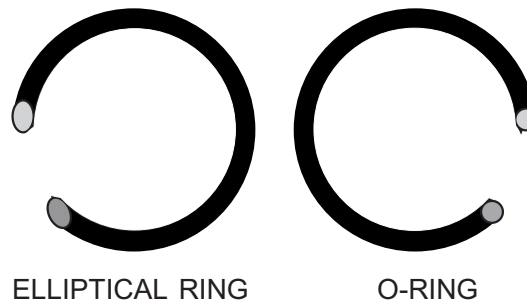

Figure 8-11.—Hydraulic seals.

temperatures ranging from -65°F to $+160^{\circ}\text{F}$. When new designs raised operating temperatures to a possible $+275^{\circ}\text{F}$, more compounds were developed and perfected.

Recently, newer compounds were developed under MS (Military Standard) specifications that offered improved low-temperature performance without sacrificing high-temperature performance. These superior materials were adopted in the MS28775 O-ring, which is replacing AN6227 and AN6230 O-rings, and the MS28778 O-ring, which is replacing the AN6290 O-ring. These O-rings are now standard for systems where the operating temperatures may vary from -65°F to $+275^{\circ}\text{F}$.

Packings used in naval aircraft hydraulic installations are manufactured from synthetic rubber. They are used in units that contain moving parts, such as actuating cylinders, selector valves, etc. Although packings are made in many forms, the O-ring type is most widely used. The U-rings, V-rings, and other various types are obsolete in most cases.

The O-ring packing seals effectively in both directions. This sealing is done by distortion of its elastic compound. Views A and C of figure 8-12 show O-rings of the proper size and installed in grooved seats. Notice that the clearance for the O-rings is less than their free outer diameter. The cross sections of the O-rings are squeezed out of round prior to the application of pressure. In this manner, contact is

ensured with the inner and outer walls of the passage under static (no pressure) conditions. Views B and D of figure 8-12 show the action of the O-rings when pressure is applied. You should also observe, in views C and D of figure 8-12, that backup rings are installed. In hydraulic systems of 1,500-psi pressure or less, AN6227B, AN6230B, and MS28775 packings are used. In such installations, backup rings are not required, although they are desirable. In most modern aircraft with hydraulic system pressures up to 3,000 psi, backup rings are used in conjunction with the MS28775 packings.

Gaskets are used in the sealing of boss fittings, end caps of actuators, piston accumulators, and other installations where moving parts do not come in contact with the seal. Normally, the type of gasket used is an O-ring. In some cases it might be the same seal that is used as a packing in other installations, or it may be one that is manufactured only for use as a gasket.

In hydraulic systems where the operating temperature ranges from -65°F to $+160^{\circ}\text{F}$, the AN6290, MS28778, AN6230B-1 through -25, MS28775-013 through -028, -117 through -149, and -223 through -247 O-rings are intended for use as gaskets. In systems where temperature limits range from -65°F to $+275^{\circ}\text{F}$, MS28778 and designated sizes of MS28775 O-rings are used as gaskets. Normally, O-rings designated as MS28778 should be used only in connections with straight thread tube fittings, such as boss fittings and end caps of check valves, etc.

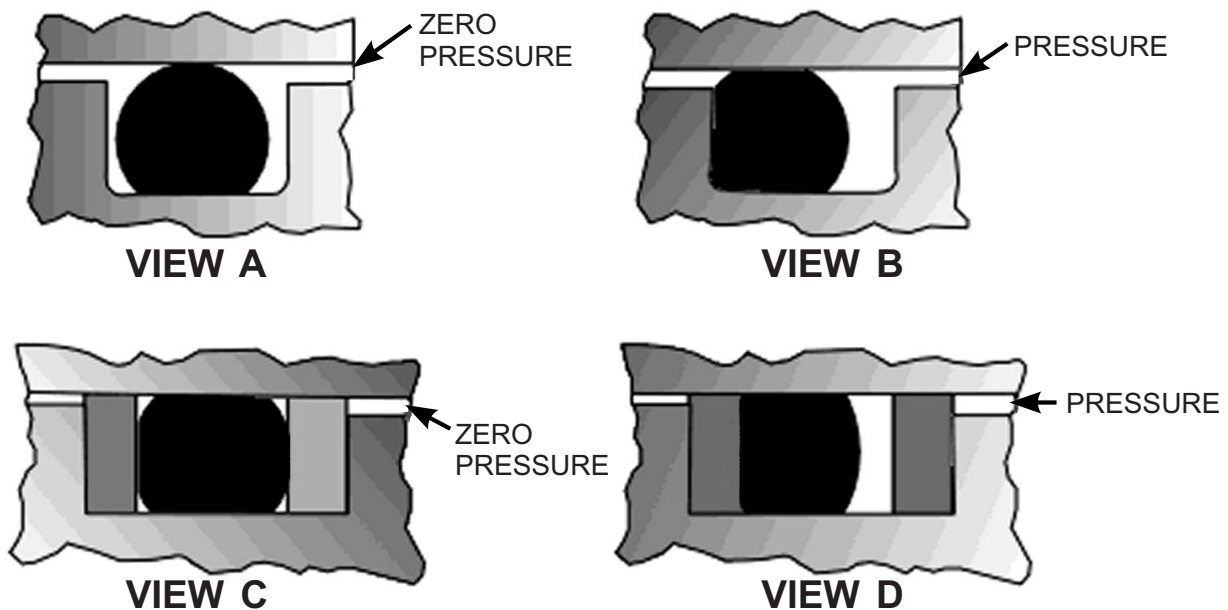

Figure 8-12.—Action of O-rings.

AMf08012

Identification

O-rings are manufactured according to military specifications and are identified from the technical information printed on the O-ring package. See figure 8-13. The size of O-rings cannot be positively identified by visual examination without the use of special equipment. For this reason, O-rings are made available in individual, hermetically sealed envelopes labeled with all the necessary pertinent data.

NOTE: Colored dots, dashes, and stripes or combinations of dots and dashes on the surface of the O-ring are no longer used for identification of O-rings. O-rings still found with these color identification markings are NOT to be used in naval aircraft hydraulic systems or components and should be depleted from stock.

Figure 8-13 shows the information printed on an O-ring package that is essential to determine the intended use, qualifications, and age limitations. The manufacturer's cure date is one of the more important printed items listed on the package. This cure date is denoted in quarters. For example, the cure date 2Q82 indicates that the O-ring was manufactured during the second quarter of 1982. Synthetic rubber parts manufactured during any given quarter are not considered one quarter old until the end of the succeeding quarter. Most O-ring age limitation is determined by this cure date, anticipated service life, and replacement schedule.

1	KZ5330-833-7491
2	PACKING PREFORMED SYN. RUBBER
3	1 EACH (MS28778-5)
4	DISC-38329
5	A-5/70
6	SR 810-B-90
7	MFD. DATE 4-70 CURE DATE 2Q70
8	STILLMAN RUBBER CO. (MFGR/CONTR)
9	MIL-G-5510A

AMf08013

1. STOCK NUMBER
2. NOMENCLATURE
3. PART NUMBER
4. CONTRACT NUMBER
5. PRESERVATION
6. RUBBER COMPOSITION NUMBER
7. DATE OF MANUFACTURE AND CURE DATE
8. MANUFACTURER
9. MILITARY SPECIFICATION NUMBER

Figure 8-13.—O-ring package identification.

Age limitation of synthetic rubber O-rings is based on the fact that the material deteriorates with age. O-ring age is computed from the cure date. The term *cure date* is used in conjunction with replacement kits, which contain O-rings, parts, and hardware for shop repair of various components. O-ring cure dates also provide bases for O-ring replacement schedules, which are determined by O-ring service life. The service life (estimated time of trouble-free service) of O-rings also depends upon such conditions as use, exposure to certain elements, both natural and imposed, and subjection to physical stress. Operational conditions imposed on O-rings in one component may necessitate O-ring replacement more frequently than replacement of identical O-rings in other components. It is necessary to adhere to the recommended replacement schedule for each individual component. The age of O-rings in a spare part is determined from the assembly date recorded on the service or identification plate and/or on the exterior of the container. All O-rings over 24 months old should be replaced or, if nearing their age limit (24 months), should not be used for replacement.

Storage

Proper storage practices must be observed to prevent deformation and deterioration of rubber O-rings. Most synthetic rubbers are not damaged by several years of storage under ideal conditions. However, most synthetic rubbers deteriorate when exposed to heat, light, oil, grease, fuels, solvents, thinners, moisture, strong drafts, or ozone (form of oxygen formed from an electrical discharge). Damage by exposure is magnified when rubber is under tension, compression, or stress.

There are several conditions to be avoided, which include the following:

- Deformation as a result of improper stacking of parts and storage containers
- Creasing caused by a force applied to corners and edges, and by squeezing between boxes and storage containers
- Compression and flattening, as a result of storage under heavy parts
- Punctures caused by staples used to attach identification
- Deformation and contamination due to hanging the O-rings from nails or pegs

O-rings should be kept in their original envelopes, which provide preservation, protection, identification, and cure date. Contamination is caused by piercing the sealed envelopes to store O-rings on rods, nails, or wire hanging devices. Contamination may be caused by fluids leaking from parts stored above and adjacent to O-ring surfaces. Contamination can also be caused by adhesive tapes applied directly to O-ring surfaces. A torn O-ring package should be secured with a pressure-sensitive, moistureproof tape, but the tape must not contact the O-ring surfaces. O-rings should be arranged so the older seals are used first.

Removal and Installation

The successful operation of a hydraulic system and the units within depends greatly upon the methods and procedures used in handling and installing hydraulic seals. These seals are comparatively soft and should not be subjected to any nicks, scratches, or dents. They should be kept free of dirt and foreign matter and should not be exposed to extreme weather conditions.

When hydraulic seals are chosen for installation, they should not be picked up with sharp instruments, and the preservative should not be removed until they are ready for installation.

During the installation or removal of hydraulic seals, as well as other tasks, your best friend is the correct tool. A variety of these tools may be used on any given job. Suggestions for fabricating typical tools for use in replacing and installing O-rings and backup rings are shown in figure 8-14. These tools should be fabricated from soft metal such as brass and aluminum; however, tools made from phenolic rods, plastics, and woods may also be used.

When removing or installing O-rings, avoid using pointed or sharp-edged tools that might cause scratching or marring of hydraulic component surfaces or cause damage to the O-rings. While using the seal removal and the installation tools, contact with cylinder walls, piston heads, and related precision components is not desirable. With practice, you should become proficient in using these tools.

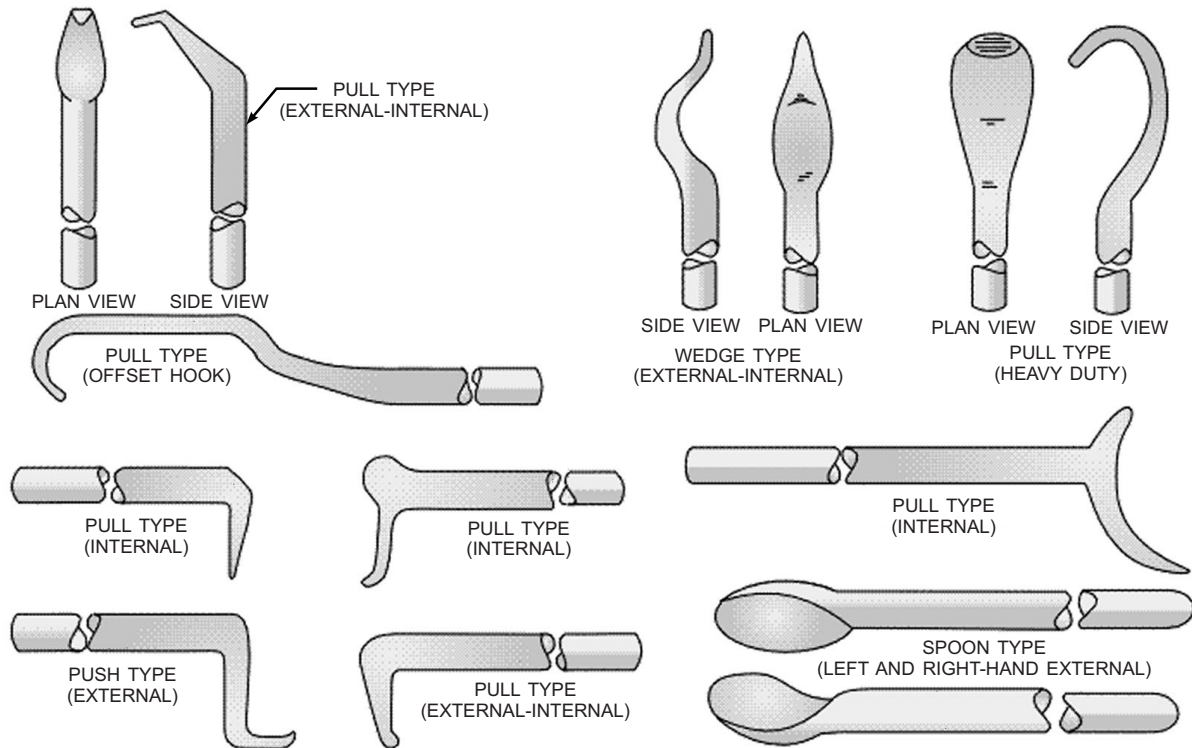

AMf08014

Figure 8-14.—Typical O-ring installation and removal tools.

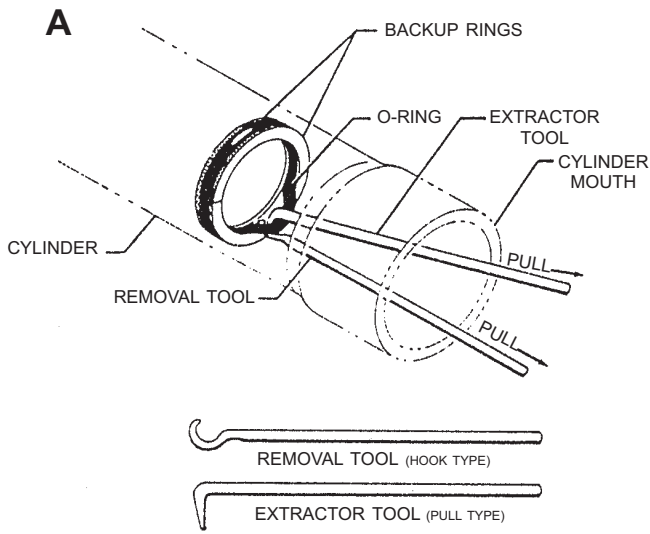

INTERNAL O-RING REMOVAL
(USING PULL TYPE EXTRACTOR AND HOOK TYPE REMOVAL TOOLS)

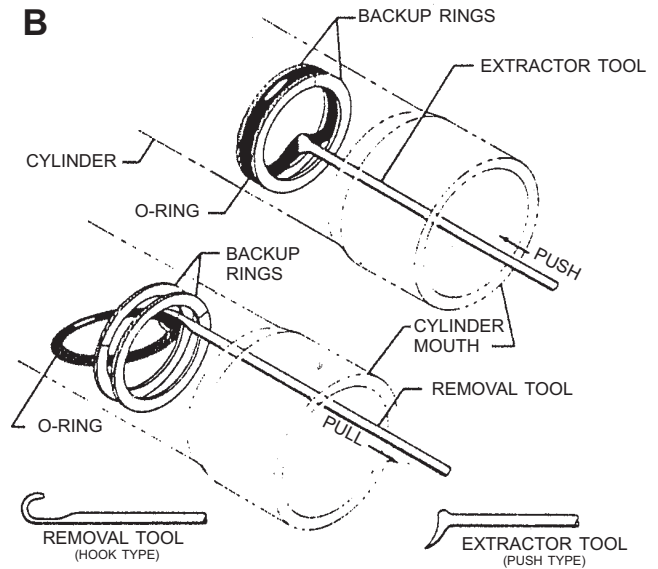

INTERNAL O-RING REMOVAL
(USING PUSH TYPE EXTRACTOR AND HOOK TYPE REMOVAL TOOLS)

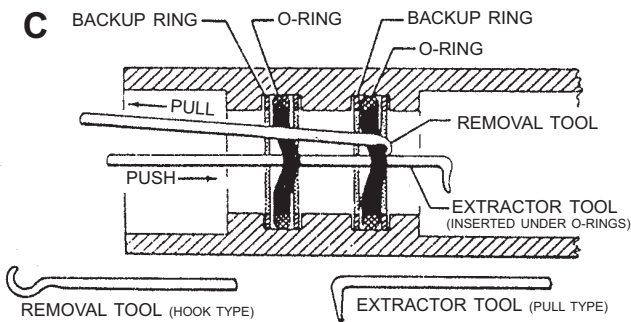

DUAL INTERNAL O-RING REMOVAL
(USING PUSH TYPE EXTRACTOR AND HOOK TYPE REMOVAL TOOLS)

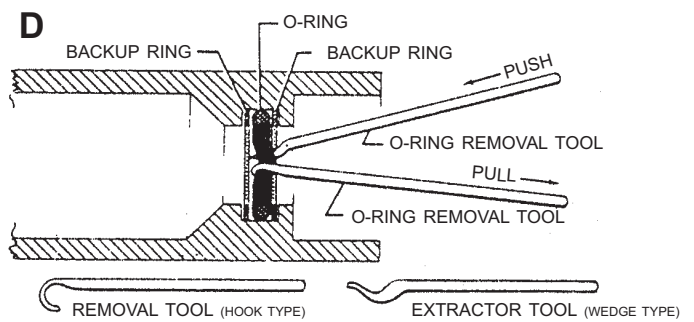

INTERNAL O-RING REMOVAL
(USING WEDGE TYPE EXTRACTOR AND HOOK TYPE REMOVAL TOOLS)

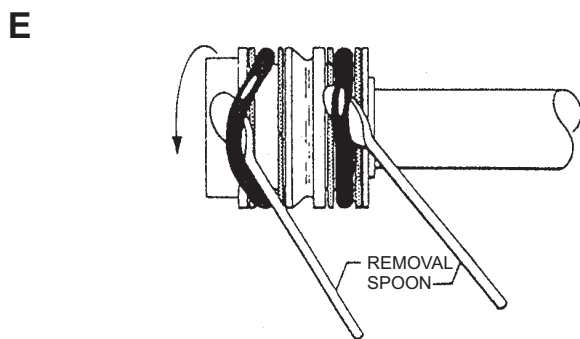

EXTERNAL O-RING REMOVAL
(USING SPOON TYPE EXTRACTOR REMOVAL TOOLS)

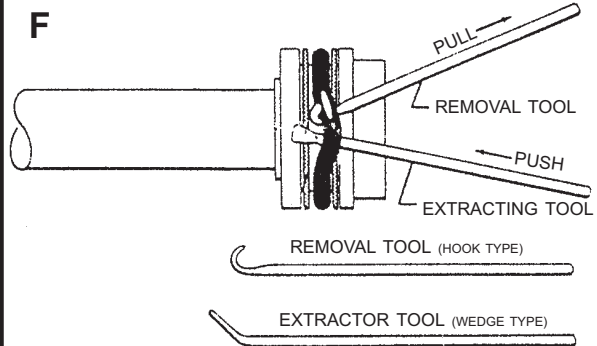

EXTERNAL O-RING REMOVAL
(USING WEDGE TYPE EXTRACTOR AND HOOK TYPE REMOVAL TOOLS)

AMf08015

Figure 8-15.—O-ring removal.

Notice in view A of figure 8-15 how the hook-type removal tool is positioned under the O-ring, and then lifted to allow the extractor tool, as well as the removal tool, to pull the O-ring from its cavity. View B of figure 8-15 shows the use of another type of extractor tool in the removal of internally installed O-rings. In view C of figure 8-15, notice the exterior tool positioned under both O-rings at the same time. This method of manipulating the tool positions both O-rings, which allows the hook-type removal tool to extract both O-rings with minimum effort. View D of figure 8-15 shows practically the same removal as view C, except for the use of a different type of extractor tool.

The removal of external O-rings is less difficult than the removal of internally installed O-rings. Views E and F of figure 8-15 shows two accepted removal methods. View E shows the use of a spoon-type extractor, which is positioned under the seal. After the O-ring is dislodged from its cavity, the spoon is held stationary while simultaneously rotating and withdrawing the piston. View F of figure 8-15 is similar to view E, except only one O-ring is installed, and a different type of extractor tool is used. The wedge-type extractor tool is inserted beneath the O-ring; the hook-type removal tool hooks the O-ring. A slight pull on the latter tool removes the O-ring from its cavity.

After the removal of all O-rings, it is mandatory that you clean the affected parts that will receive new O-rings. Ensure that the area used for such installations is clean and free from all contamination.

Each replacement O-ring should be removed from its sealed package and inspected for defects such as blemishes, abrasions, cuts, or punctures. Although an O-ring may appear perfect at first glance, slight surface flaws may exist. These are often capable of preventing satisfactory O-ring performance under the variable operating pressures of aircraft systems. O-rings should be rejected for flaws that will affect their performance.

Such defects are difficult to detect. One aircraft manufacturer recommends using a 4-power magnifying glass with adequate lighting to inspect each ring before it is installed.

By rolling the ring on an inspection cone or dowel, the inner diameter surface can also be checked for small cracks, particles of foreign material, and other irregularities that will cause leakage or shorten the life of an O-ring. The slight stretching of the ring when it is rolled inside out will help to reveal some defects not otherwise visible. A further check of each O-ring should be made by stretching it between the fingers, but

you must take care not to exceed the elastic limits of the rubber. Following these inspection practices will prove to be a maintenance economy. It is far more desirable to take care identifying and inspecting O-rings than to repeatedly overhaul components with faulty seals.

After inspection and prior to installation, immerse the O-ring in clean hydraulic fluid. During the installation, avoid rolling and twisting the O-ring to maneuver it into place. If possible, keep the position of the O-ring's mold line constant. When the O-ring installation requires spanning or inserting through sharp threaded areas, ridges, slots, and edges, use protective measures, such as O-ring entering sleeves, as shown in view A of figure 8-16. If the recommended O-ring entering sleeve (soft thin-wall metallic sleeve) is not available, paper sleeves and covers may be fabricated by using the seal package (gloss side out) or lint-free bond paper. See views B and C of figure 8-16.

Adhesive tapes should not be used to cover danger areas on components. Gummy substances left by the adhesives are extremely detrimental to hydraulic systems.

After the O-ring is placed in the cavity provided, gently roll the O-ring with the fingers to remove any twist that might have occurred during installation.

Backup Rings

Backup rings are used to support O-rings and to prevent O-ring deformation and resultant leakage. Two types of backup rings are used in naval aircraft—Teflon® single and double spiral.

Teflon® rings are made from a fluorocarbon-resin material, which is tough, friction-resistant, and more durable than leather. Precautions similar to those applicable to O-rings must be taken to avert contamination of backup rings and damage to hydraulic components. Teflon® backup rings may be stocked in individual sealed packages similar to those in which O-rings are packed, or several may be installed on a cardboard mandrel.

If unpackaged rings are stored for a long period of time without the use of mandrels, a condition of overlap may develop. To eliminate this condition, stack Teflon® rings in a mandrel of a diameter comparable to the desired diameter of the spiral ring. Stack and clamp the rings with their coils flat and parallel. Then place the rings in an oven at a maximum temperature of 350°F for a period of approximately 10 minutes. The rings are then removed and water quenched.

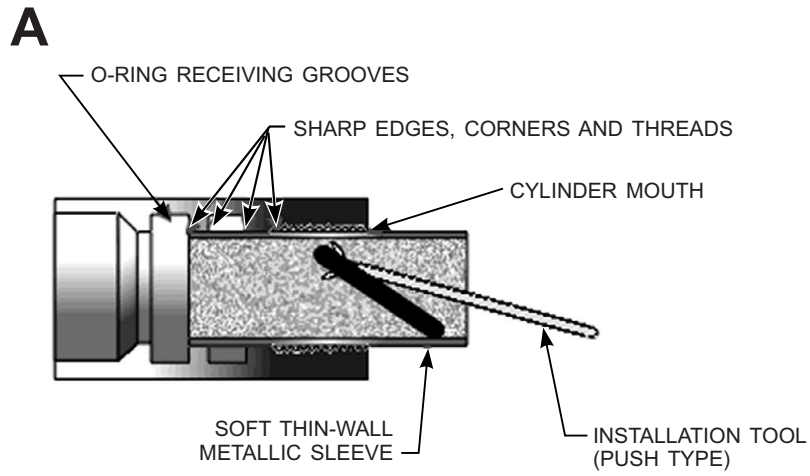

INTERNAL O-RING INSTALLATION
 (USING METALLIC SLEEVE TO AVOID O-RING
 DAMAGE FROM SHARP EDGES OR THREADS,
 AND PUSH TYPE INSTALLATION TOOL)

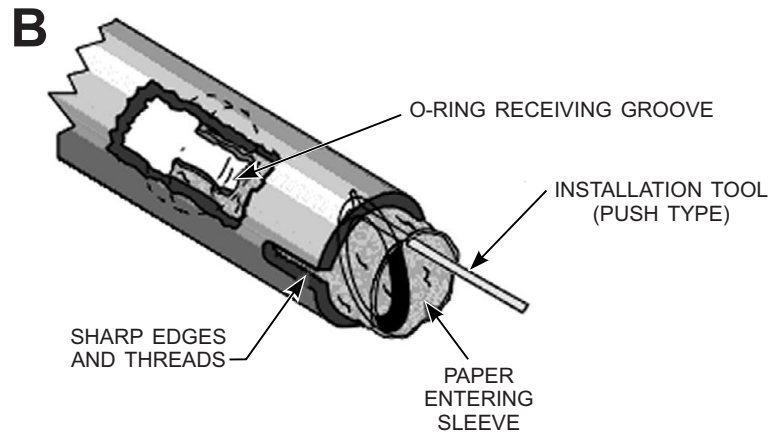

INTERNAL O-RING INSTALLATION
 (USING PAPER ENTERING SLEEVE TO AVOID O-RING
 DAMAGE FROM SHARP EDGES OR THREADS,
 AND PUSH TYPE INSTALLATION TOOL)

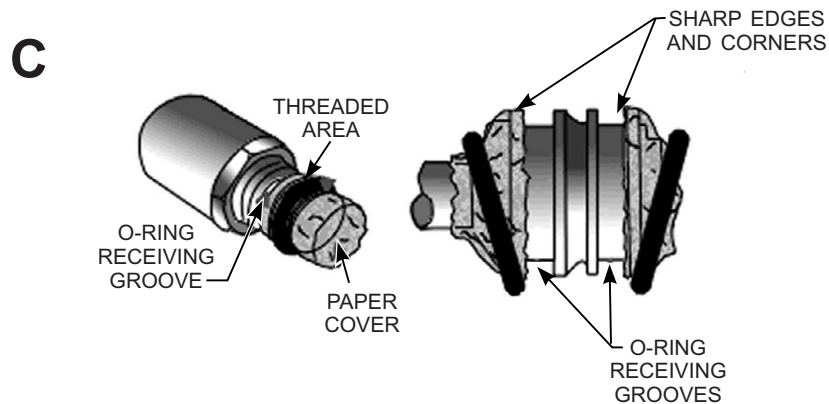

EXTERNAL O-RING INSTALLATION
 (USING PAPER COVER TO AVOID O-RING DAMAGE
 FROM SHARP EDGES OR THREADS)

AMF08016

Figure 8-16.—O-ring installation.

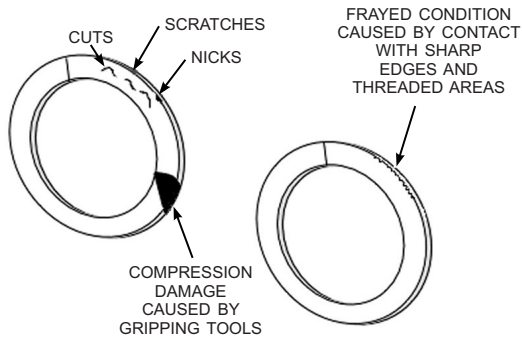

AMF08017

Figure 8-17.—Teflon® backup ring damages caused by improper handling.

NOTE: After this treatment, rings should be stored at room temperature for a period of 48 hours prior to use.

IDENTIFICATION.—Backup rings are not color-coded or otherwise marked and must be identified from package labels. Backup rings made from Teflon® do not deteriorate with age, and are unaffected by any other system fluid or vapor. They

tolerate temperature extremes in excess of those encountered in high-pressure hydraulic systems. The specification number of a backup ring can be found on the package label. This specification number is followed by a dash (-) and a number. The number following the dash indicates the size. In some cases, this number is directly related to the dash number of the O-ring for which the backup ring is intended to be used. For example, the single spiral Teflon® ring, MS28774-6, is used with MS28775-006 O-ring; and the double spiral Teflon® ring, MS28782-1, is used with the AN6227B-1 O-ring.

INSTALLATION.—Care must be taken during the handling and installation of backup rings. If possible, backup rings should be inserted by hand and without the use of sharp tools. The Teflon® backup rings must be inspected prior to reuse for evidence of compression damage, scratches, cuts, nicks, and fraying conditions, as shown in figure 8-17.

To install the Teflon® backup ring (fig. 8-18), the following steps should be used.

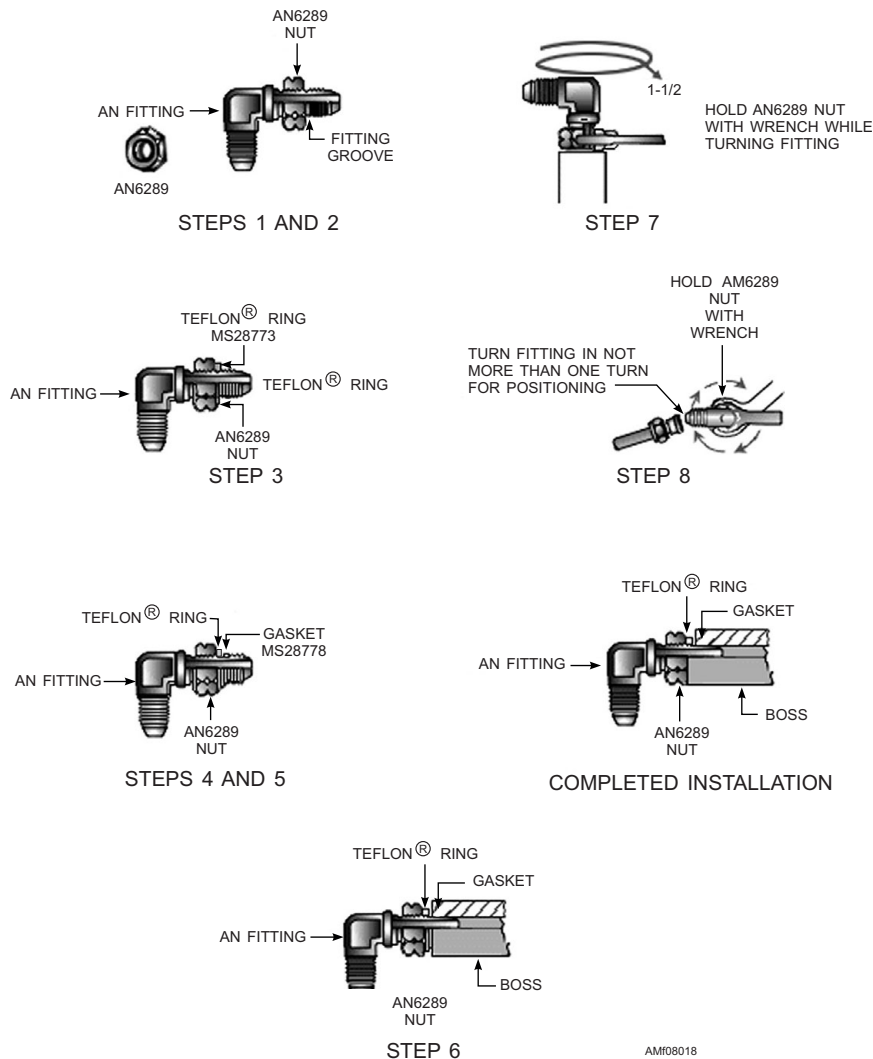

Figure 8-18.—Properly installed gasket and backup ring.

1. Examine the fitting groove for roughness that might damage the seal.
2. Position the jam nut well above the fitting groove, and coat the male threads of the fitting sparingly with hydraulic fluid.
3. Install the backup ring in the fitting groove, and work the backup ring into the counterbore of the jam nut.
4. Install the gasket in the fitting groove against the backup ring.
5. The jam nut is then turned down until the packing is pushed firmly against the threaded portion of the fitting.
6. Install the fitting into the boss, and turn until the packing has contacted the boss. (The jam nut must turn with the fitting.)
7. Hold the jam nut and turn the fitting an additional one-half turn.

8. The fitting is then positioned by turning it not more than one turn.
9. Hold the fitting in the desired position, and turn the nut down tight against the boss.

When Teflon® spiral rings are being installed in internal grooves, the ring must have a right-hand spiral. View A of figure 8-19 shows the method used to change directions of the spiral. The Teflon® ring is then stretched slightly prior to installation into its groove. While the Teflon® ring is being inserted in the groove, rotate the component in a clockwise direction. This action will tend to expand the ring diameter and reduce the possibility of damage to the ring.

When Teflon® spiral rings are being installed in external grooves, the ring should have a left-hand spiral. As the ring is inserted into the groove, rotate the component in a clockwise direction. This action will tend to contract the ring diameter and reduce the possibility of damage to the ring.

CHANGING DIRECTION OF ROTATION
OF SPIRAL BACKUP RINGS

A REVERSE THE SPIRAL OF A SR-14 RING (NORMALLY RH) TO A LEFT HAND SPIRAL.

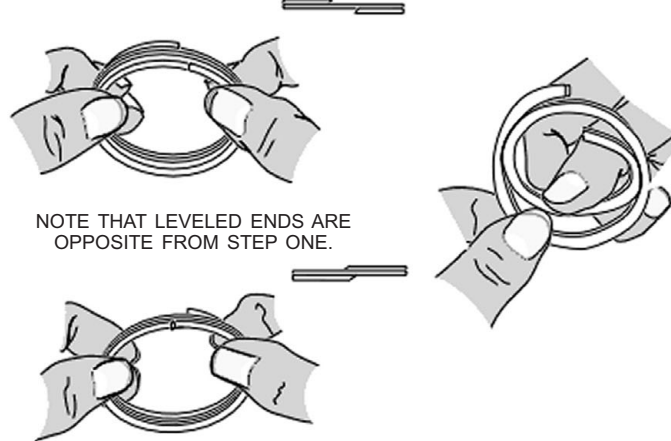

B TO PREVENT OVERLAP, SLIGHTLY STRETCH THE TEFLON® RING BEFORE INSTALLING INTO INTERNAL GROOVES.

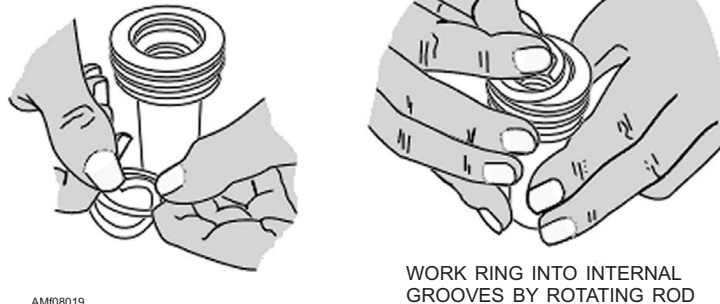

AM08019

Figure 8-19.—Installation of Teflon® backup rings (internal).

Backup rings may be installed singly, if pressure acts only upon one side of the seal. In this case, the backup ring is installed next to the O-ring, opposite the pressure force. See view A of figure 8-20. When dual backup rings are installed, the split scarfed ends must be staggered, as shown in view B of figure 8-20. View C of figure 8-20 shows an improper dual ring installation.

Wipers

Wipers (scrapers) are used to clean and lubricate the exposed portion of piston shafts. This prevents foreign matter from entering the system and scoring internal surfaces. Wipers may be of the metallic (usually copper base alloys) or felt types. They are used in practically all landing gear shock struts and most actuating cylinders. At times, they are used together, the felt wiper being installed behind the metallic wiper. Normally, the felt wiper is lubricated with system hydraulic fluid from a drilled bleed passage or from an external fitting.

Wipers are manufactured for a specific hydraulic component and must be ordered for that application. Wipers are normally inspected and changed, if necessary, while component repair is in process.

Metallic wipers are formed in split rings for ease in installation, and they are manufactured slightly undersize to ensure a tight fit. One side of the metallic wiper has a lip, which should face outward upon installation. Metallic wipers must be inspected for foreign matter and condition, and then installed by sliding them over the piston shaft in the proper order, as directed by the applicable MIM.

The felt wiper may be a continuous felt ring or a length of felt with sufficient material to overlap its ends. The felt wiper should be soft, clean, and well saturated in hydraulic fluid during installation.

Protective Closures

Contamination is hazardous and expensive. To protect hydraulic systems from contaminants, use protective closures. Two types of protective metal closures are approved for sealing hydraulic equipment. They are caps and plugs conforming to appropriate military specifications. Guidelines for selection and use of protective closures for hydraulic equipment are as follows: Use caps and plugs of the proper size and material. Never blank-off openings with wooden plugs, paper, rags, tape, or other unauthorized devices. Use

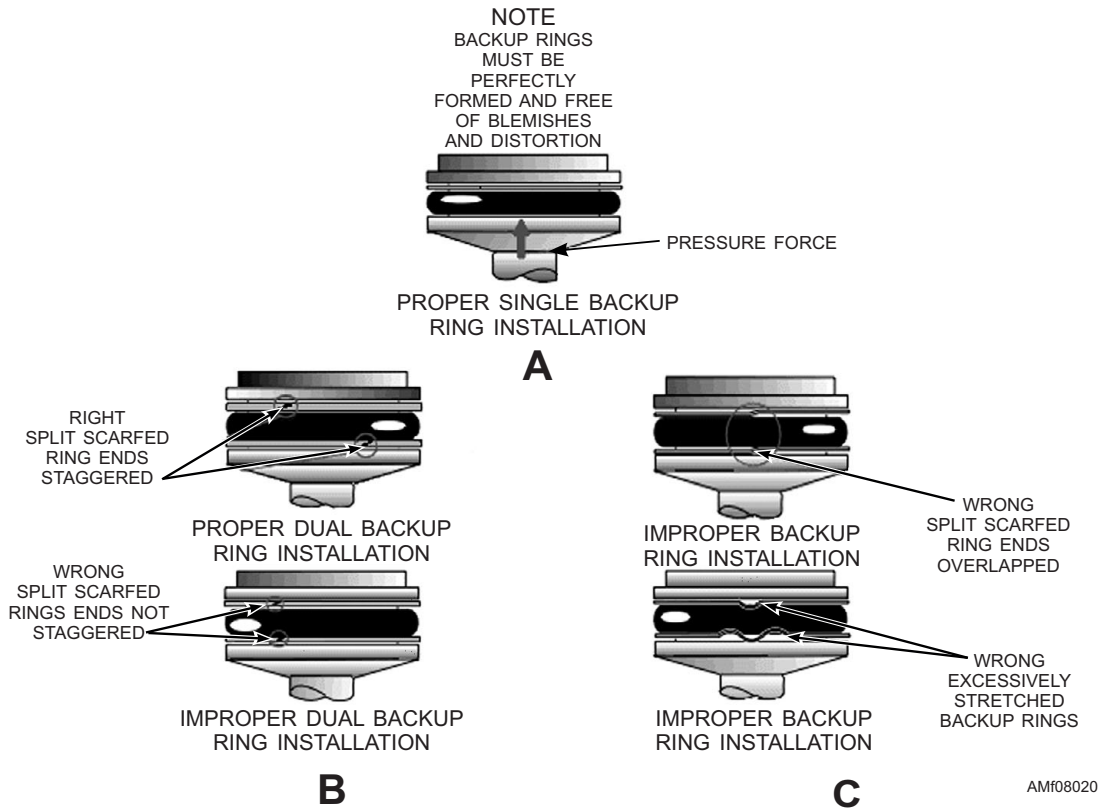

Figure 8-20.—Teflon® backup ring installation (external).

closures of metal construction conforming to specifications listed in table 8-4 for sealing hydraulic system equipment, lines, tubes, accessories and components.

Figure 8-21 shows typical blank-off plates. In all cases where there is a choice between an internal or external installation, use the external type of closure. Use metal protective closures to seal open ports of all hydraulic lines and accessories. Use metal protective closures to seal new and reusable hydraulic tubing and hose assemblies. Plastic closures may be used to seal electrical fittings and receptacles or other nonfluid openings where contamination is not considered a problem. Keep all protective closures clean, sorted by size, properly identified, and stored in readily accessible bins. Check protective closures visually for cleanliness, thread damage, or sealing deformation before using.

Rubber, plastic, or unthreaded type of protective closures designed to fit over open ends of bulk hose and tubing should be used in accordance with design function only. Do not use this type of protective closure as a plug for insertion into open lines, hoses, or ports of hydraulic equipment. Remove protective closures before installing equipment. If an opening normally requiring protection is found uncovered, the part or assembly should be cleaned and checked before installation or assembly.

Q8-23. What component is used to provide a means of quickly disconnecting a line without the loss of hydraulic fluid?

Q8-24. When the quick-disconnect coupling is disconnected, what component prevents the loss of fluid and entrance of air?

Table 8-4.—Protective Caps and Plugs

TYPE	APPLICATION	APPLICABLE SPECIFICATION
Cap	Flared Fitting	MIL-C-5501 (Preferred) or NAS 817
Cap	Beaded Hose Connection	MIL-C-5501
Cap	Pipe Thread	MIL-C-5501
Cap	Assembly, Pressure Seal Flared Tube Fitting	AN929
Cap	Pressure Seal, Flareless Tube Fitting	MS21914
Plug	Flared Tube End and Straight Threaded Boss	MIL-C-5501 (Preferred) or NAS-818 or AN806
Plug	Flareless Tube End	MIL-C-5501 (Preferred) or MS21913
Plug	Flared Tube Precision Type	MS24404
Plug	Pipe Thread	MIL-C-5501
Plug	Bleeder, Screw Thread	AN814
Plug	Machine Thread O-Ring Seal	MS9015
Plug	Machine Thread AMS 5646 Preformed Packing	MS9404
Plug	Bleeder, Screw Thread Precision Type	MS24391
<p>NOTE:</p> <p>1. When ordering from supply, be sure to specify metal caps or plugs.</p>		

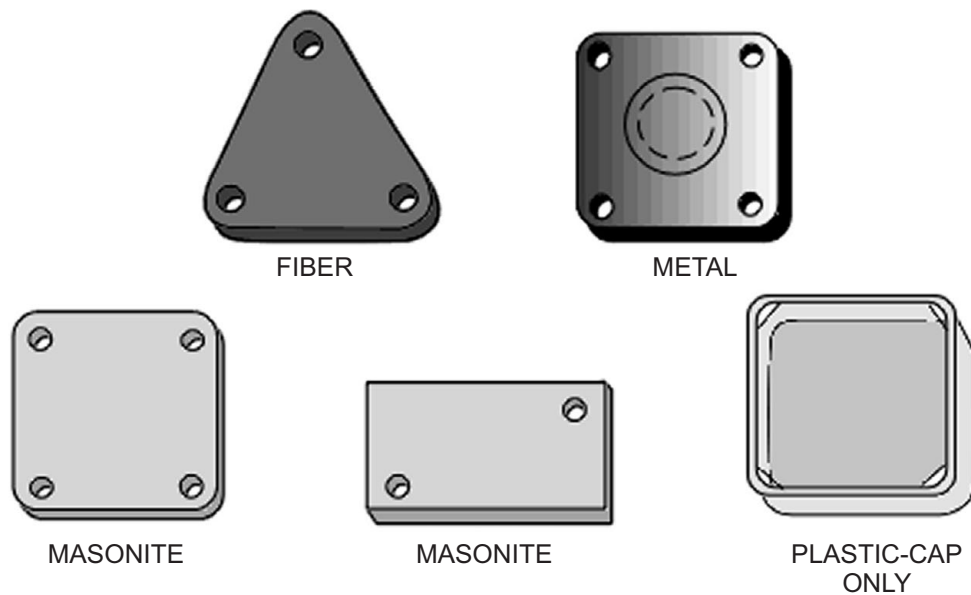

AMf08021

Figure 8-21.—Typical blank-off plates.

- Q8-25. A hydraulic seal that is used between two stationary items is referred to by what name?*
- Q8-26. High-operating pressures require what components to be used with O-rings?*
- Q8-27. A damaged O-ring storage envelope should be repaired with what type of tape?*
- Q8-28. Tools used for installing and removing O-rings should be made from what material?*
- Q8-29. What is the shelf life of Teflon® backup rings?*
- Q8-30. What is the purpose of a wiper in an exposed piston shaft installation?*

CHAPTER 9

FLUID SERVICING AND SUPPORT EQUIPMENT

INTRODUCTION

Fluid servicing consists of adding new filtered hydraulic fluid to a system, which replaces fluid lost through leakage, system maintenance, or malfunction. The type of support equipment varies, depending on the type of aircraft. As an AM, you must know this equipment and how to operate it. Hydraulic support equipment (SE) is used to service and test hydraulic systems and components. To use the equipment, you must understand each piece of hydraulic SE so you can maintain aircraft hydraulic systems. The maintenance and operation of specific SE units are described in applicable manufacturer's operation and service instructions manual (listed in the Naval Aeronautical Publications Index (NAPI), under "Test Equipment," 17 series group), and in the maintenance instructions peculiar to the specific aircraft.

FLUID SERVICING EQUIPMENT

LEARNING OBJECTIVE: Identify the support equipment used to service and test aircraft hydraulic systems and components.

All maintenance levels use support equipment (SE). General types of hydraulic SE are hydraulic fluid dispensing equipment, portable hydraulic test stands, and stationary hydraulic test stands.

HYDRAULIC FLUID DISPENSING EQUIPMENT

Hydraulic fluid dispensing units are portable. They are used to replenish hydraulic fluid lost or otherwise removed from a system. They provide a means of dispensing new filtered fluid under pressure in a manner that minimizes the introduction of external contaminants. Several different types of hydraulic fluid dispensing equipment are available.

Model H-250-1 Hydraulic Servicing Unit

The Model H-250-1 hydraulic servicing unit is a 1-gallon servicing unit (fig. 9-1). It provides a way of servicing systems by hand-pumping filtered fluid directly from the original container without exposing

the fluid to open air or to other atmospheric contamination. The unit accepts the standard, 1-gallon container, which, when installed, serves as a reservoir. The servicing unit has 3-micron (absolute) filtration to prevent particulate contamination of a system by new fluid that may not meet the prescribed cleanliness prior to packaging. Contamination in new fluid is rare, but it does occur.

The original fluid container serves as a reservoir for the H-250-1 servicing unit. This container is not opened until it is placed in the unit, and the handle assembly pressed into a locked position. When the handle is locked, the can is sealed into the unit by cleanly piercing its top and bottom. This action automatically destroys the can's potential for reuse. The H-250-1 servicing unit is equipped with a top-piercing pin, which is drilled to provide the can with atmospheric venting through a 5-micron filter. Also, it has a check valve to minimize airborne particulate and moisture contamination. The lower piercing pin is drilled so the hydraulic fluid can reach the pump through a passage in the base casting and a 3-micron filter. The filter is a nonbypass type. When it becomes loaded, the unit is inoperative. The filter housing is designed so that the pump won't operate if a filter element has not been installed.

A pressure gauge, an air trap, and a manual air bleed valve are attached directly to the pump assembly base. The air trap automatically removes any air present in the fluid at the pump chamber and retains it in a separate trap. Air collected in the trap is vented from the unit by manually operating a spring-loaded, air bleed valve.

The H-250-1 servicing unit has an 8-foot service hose that is equipped with a 3-micron, in-line filter connected at the discharge end, which prevents reverse flow contamination through the hose. There are several types of disconnect fittings on the reservoir service units of naval aircraft. There are no mating fittings provided with the unit. Each activity must procure and install the disconnect fitting required for compatibility with the aircraft supported. Both male and female fittings are procured so that half can be installed on the hose end and half on the bracket provided. The bracket-mounted fittings will provide a

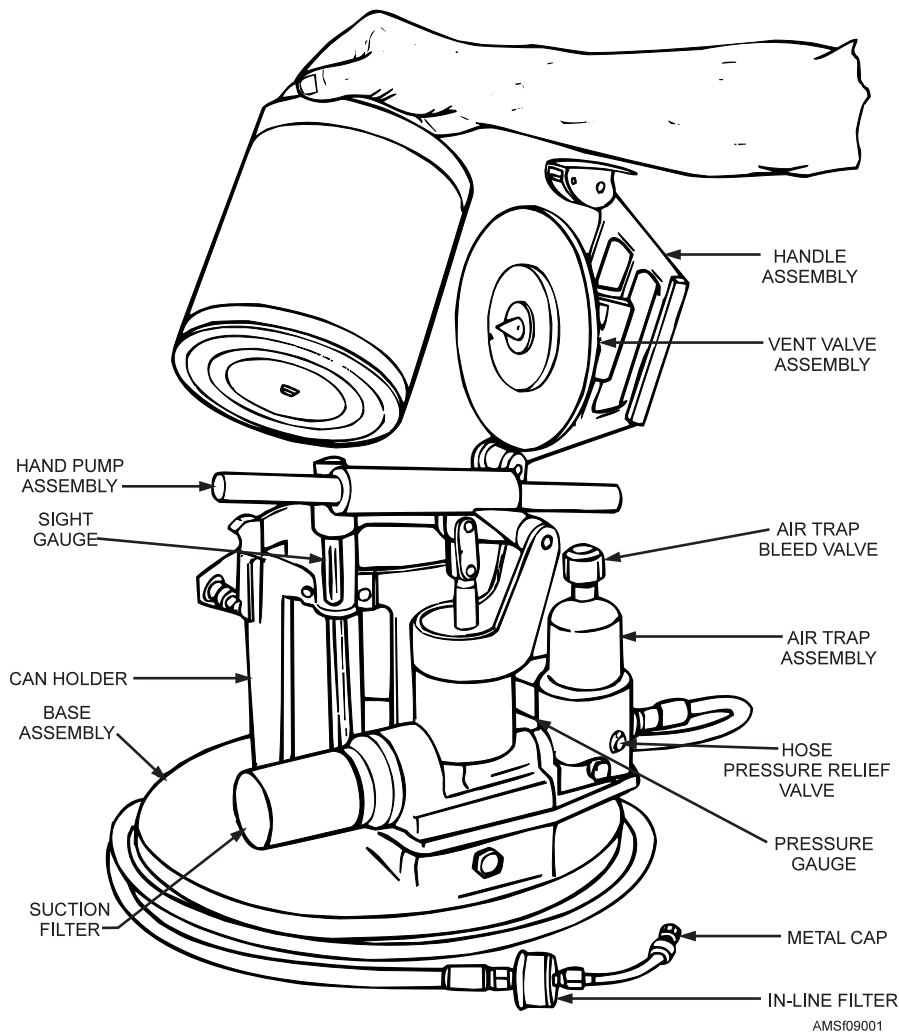

Figure 9-1.—Insertion of can into Hydraulic Servicing Unit H-250-1.

contamination-free means of stowing the discharge end of the service hose when the equipment is not in actual use.

Model HSU-1 Fluid Service Unit

The Model HSU-1 fluid service unit (fig. 9-2) is operated similarly to the H-250-1 unit, except that it has a fluid-holding capacity of 3 gallons. Like the H-250-1 servicing unit, the HSU-1 accepts a standard 1-gallon container and uses it as a fluid reservoir. Additionally, it contains an integral 2-gallon reservoir assembly. It has 3-micron filtration incorporated to ensure delivery of contamination-free fluid.

The integral 2-gallon reservoir assembly is made of anodized cast aluminum and (along with a hand pump assembly) is mounted to a cast aluminum base. The lower can piercer is mounted on top of the reservoir and allows fluid to flow from the installed 1-gallon container into the reservoir, automatically replenishing it. A sight gauge indicates the fluid level

of the reservoir. It reads from 0 to 2 gallons, in 1/4-gallon increments. An indicated level of 2 gallons or less means that the 1-gallon container is empty and can be removed for replacement. A capped deaeration port is located on top of the reservoir to permit bleeding the air from the pump and output hose.

Can holder and handle assemblies are mounted above the 2-gallon reservoir. The can holder positions the installed 1-gallon fluid container directly above the reservoir, and also provides a means of placing the handle assembly over the container top. The handle assembly is hinged to a bracket on the can holder assembly. It is provided with a spring-loaded latch to lock the handle in the closed position. In addition to the carrying handle itself, the handle assembly contains an upper can piercer, a vent check valve, and a filter. A vent hose is connected between the top of the reservoir (sight gauge) and the upper can piercer.

Fluid is delivered by a single-action, piston hand pump that displaces 1.5 fluid ounces per full stroke at 0

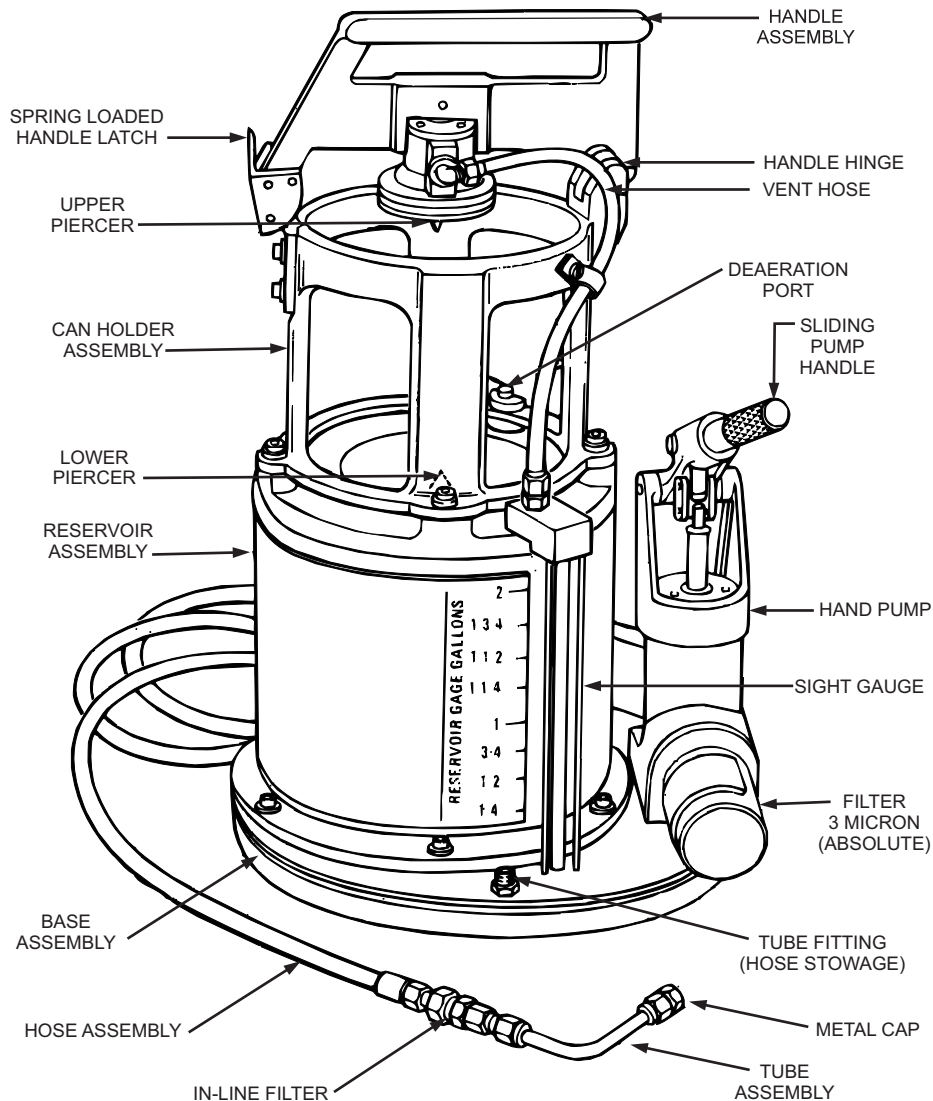

Figure 9-2.—Model HSU-1 fluid service unit.

to 250 psi. The pump is operated with a sliding pump handle, which is held in the extended or retracted position by a spring-loaded ball detent. A replaceable 3-micron (absolute) disposable filter on the pump base removes particulate contamination from the hydraulic fluid being delivered to the suction side of the pump. The filter unseats a shutoff valve, which closes the suction port whenever the filter element is being replaced.

The HSU-1 service unit is equipped with a 7-foot service hose connected to the unit's fluid output port at the pump assembly. The hose assembly ends with a short bent-tube assembly for direct connection to fill fittings on the aircraft or components being serviced. A 3-micron, in-line filter is located between the hose end and the tube. This prevents reverse-flow contamination and serves as a final filter. When the fluid service unit is not in use, it is stored by wrapping

the hose assembly around the can holder assembly and fastening the tube end to the hose storage fitting on the base.

Model 310 Fluid Service Cart

The Model 310 fluid service cart (fig. 9-3) is a hand-propelled, mobile unit designed to service aircraft hydraulic systems with fluid obtained directly from the 10-gallon container. It can be operated by one person, and it is used in those applications where the fluid capacity of the H-250-1 servicing unit (1 gallon) or HSU-1 servicing unit (3 gallons) is inadequate. The hand pump is used to deliver 3-micron (absolute) filtered fluid.

The main frame assembly of the fluid service cart consists of a two-wheel dolly having a tubular handle extending outward so you can hand push (or pull) the cart. The frame contains an inner bridle, which, with

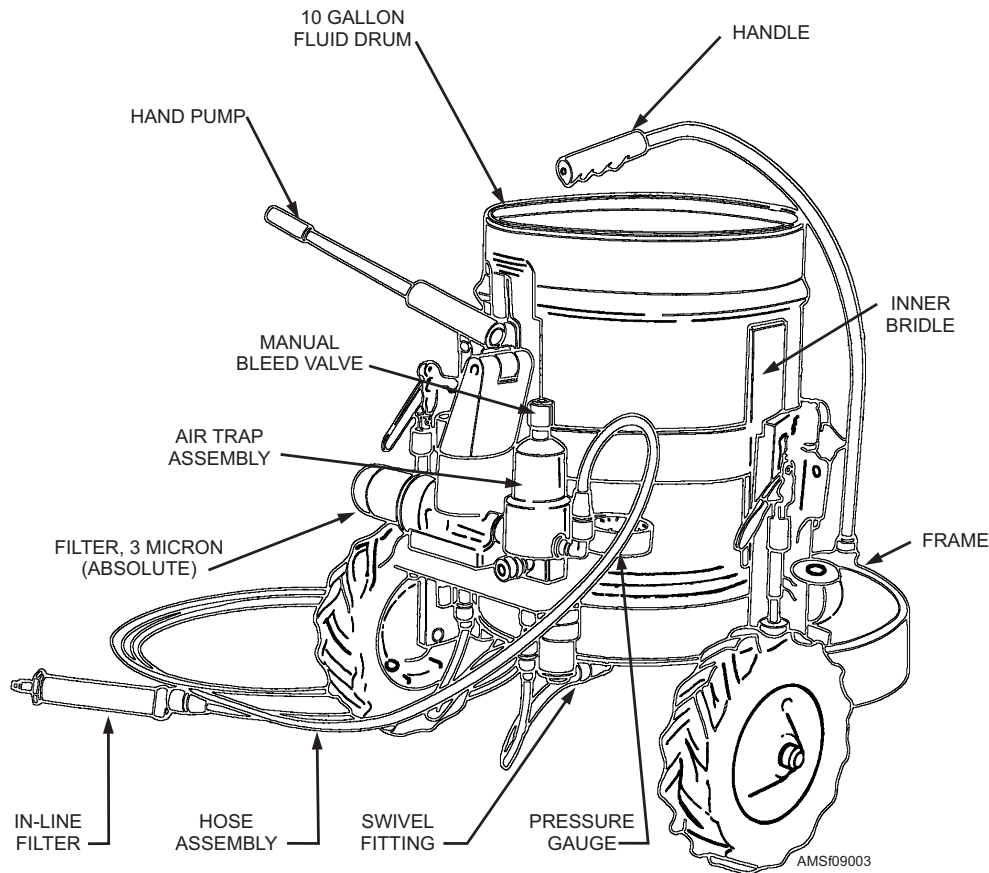

Figure 9-3.—Model 310 fluid service cart.

the cart in its upright position, may be positioned around and secured to a 10-gallon fluid drum without lifting the drum. Once it is installed in the bridle, you can move the drum using the dolly, or tilt it back 90 degrees from vertical to the operating position.

Hydraulic fluid is removed through a swivel fitting installed in a 2-inch hole. The swivel fitting is connected by a flexible hose to a single-action pump that has a displacement of 2 fluid ounces per stroke at 0 to 250 psi. A replaceable 3-micron (absolute) disposable filter installed at the pump assembly base removes particulate contamination from the fluid being delivered to the suction side of the pump. A check valve in the filter assembly prevents operation without an installed filter element.

Filtered fluid from the hand pump is routed to an air trap assembly, which contains a special chamber that removes any free air present in the fluid. The air trap assembly contains a manual bleed valve for venting collected air and a 0- to 300-psi pressure gauge for monitoring output pressure. Fluid is delivered to the system or component being serviced by a 15-foot service hose. A 3-micron, in-line filter assembly is located near the discharge end of the service hose to ensure against system contamination.

CHECKING AIRCRAFT HYDRAULIC FLUID LEVELS

There are specific procedures for checking hydraulic fluid levels in each model of aircraft. These procedures must be followed to make sure the system operates at the required fluid level. Fluid level is generally determined by an indicating device at the system reservoir. The type of indicator used varies with the aircraft model. Sight-glass, gauge, and piston-style indicators are commonly used.

There is close tolerance between the operating parts of equipment used in aircraft hydraulic systems and the level of hydraulic fluid contamination; therefore, **do not introduce foreign matter into a system being serviced.** All servicing must be accomplished by qualified personnel using authorized fluid-dispensing equipment.

The information given here gives general guidance and requirements to follow when fluid servicing hydraulic systems and components. Remember, you need to follow the procedures contained in the applicable technical manuals when you actually service hydraulic systems and components. When you service these systems, use approved fluid-dispensing

equipment that is equipped with 3-micron (absolute) filtration. Maintain equipments according to the applicable MIM and MRC. Keep hydraulic fluid dispensing equipment clean. Store it in a clean, protected environment. Service this equipment on a periodic basis, including filter servicing. Protect all fittings or hose ends with approved metal closures when not in use.

Use the correct fluids for each piece of fluid-dispensing equipment, and mark the equipment to indicate the type of fluid. Use the specified hydraulic fluid to service hydraulic systems. Take precautions to avoid accidental use of any other fluid. Do not leave hydraulic fluid in an open container any longer than necessary, particularly in dusty environments. Exposed fluid will readily collect contaminants, which could jeopardize system performance. With the exception of fluid cans or drums installed in approved dispensing units, open cans of hydraulic fluid are prohibited. Containers for disposal of used fluid must be prominently marked and identified. Empty fluid containers must be destroyed or returned to supply as appropriate.

Do not reuse hydraulic fluid drained from hydraulic equipment or components. Dispose of drained fluid immediately so it will not be accidentally reused. In the event hydraulic fluid is spilled on other parts of equipment on the aircraft, remove spilled fluid by using approved wiping materials and dry cleaning solvent MIL-PRF-680.

- Q9-1. What three factors contribute to fluid loss in a hydraulic system?*
- Q9-2. What are the three types of hydraulic SE used in the Navy?*
- Q9-3. What size filter does the H-250-1 hydraulic servicing unit use?*
- Q9-4. What is the holding capacity of the integral reservoir of a HSU-1 servicing unit?*
- Q9-5. On the HSU-1 servicing unit, the sight gauge reads from 0 to 2 gallons in what increments?*
- Q9-6. What size filter is used on the Model 310 servicing unit?*
- Q9-7. What is the length of the service hose of a Model 310 servicing unit?*
- Q9-8. What are the three most common types of fluid level indicators?*
- Q9-9. All support equipment must be maintained according to what publications?*

PORTABLE HYDRAULIC TEST STANDS

Portable hydraulic test stands are mobile sources of external hydraulic power. They can be connected to an aircraft hydraulic system to provide power normally obtained from the aircraft hydraulic pumps. The test stands provide a means of energizing the aircraft's hydraulic systems. SE is used on the flight line and in hanger work areas. In addition, portable test stands are important tools for hydraulic contamination control. They are the primary means of aircraft hydraulic decontamination.

Several types of portable stands are available. Their primary difference is their prime power source (electric motor or engine driven), functional features, and maximum flow capability.

A/M27T-5 Portable Hydraulic Power Supply

The A/M27T-5 portable hydraulic power supply (fig. 9-4), made by Janke and Company, Inc., is replacing the AHT-64 hydraulic test stand made by Teledyne Sprague Engineering. The A/M27T-5 is a modified AHT-64 portable, table hydraulic power supply unit. It is a self-contained, diesel powered, trailer-mounted unit capable of providing a source of hydraulic fluid at controlled pressures and flow rates from 0 gpm at 0 psi to 24 gpm at 3,000 psi, or 13 gpm at 5,000 psi under ambient temperatures of -25°F to +115°F and relative humidity of 95 percent. The Model 3-53 Detroit diesel engine is used in the A/M27T-5. Minor changes were made to the physical location of system components to make maintenance easier. See figure 9-5 for a view of the A/M27T-5 central panel. Table 9-1 explains the functions of each control and indicator on the panel.

A/M27T-7 Portable Hydraulic Power Supply

The portable hydraulic test stand A/M27T-7 is identical to the A/M27T-5 test stand, except that it is powered by an electric motor. The motor is capable of operating on 220/440-V, 3-phase, 60-Hz current. The principles of operation and operating procedures for the A/M27T-7 test stand are basically the same as for the A/M27T-5 test stand, with the exception of the starting and stopping procedures and the use of electrical power to operate the stand. Refer to applicable equipment manual (table 9-2) for operational and maintenance instructions. Figure 9-6 shows a typical A/M27T-7 hydraulic power supply unit. Figure 9-7 shows the primary control panel controls and indicators, and figure 9-8 shows the

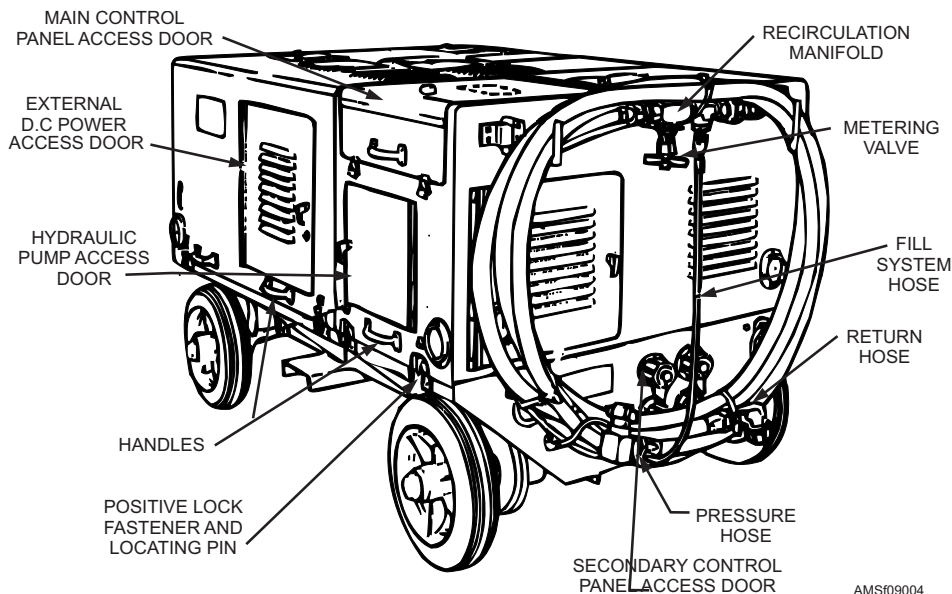

Figure 9-4.—A/M27T-5 portable hydraulic power supply, rear and right-hand side view.

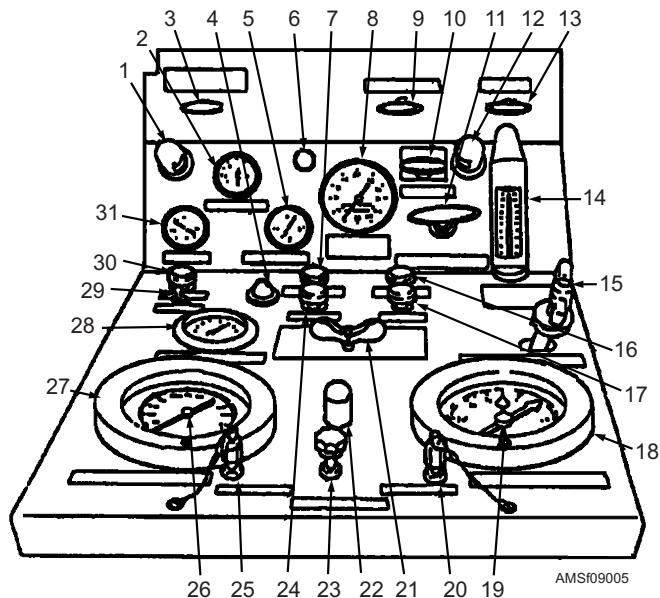

Figure 9-5.—A/M27T-5 main control panel controls and indicators.

secondary control panel controls and indicators. Table 9-3 gives a description of the primary control panel controls and functions. Table 9-4 gives a description of the secondary control panel controls and functions.

MAINTENANCE PROCEDURES

The A/M27T-5 and the A/M27T-7 operate in basically the same manner. They differ in their starting and stopping procedures. Before you use the A/M27T-5 or the A/M27T-7 test stands, you need to know how they work and the location and function of all switches, controls, and instruments. For specific instructions on its use, refer to the *Handbook of Operation, Service, and Overhaul Instruction*, NA 17-15BF-65, and the applicable MIM.

Before you operate the portable hydraulic test stand, follow the specific instructions for its inspection, turnup, aircraft connection, and operation from the applicable maintenance manuals. You should know some of the minimum general requirements about the use of all portable test stands. Locate the test stand so there is adequate room and ventilation, and where engine heat can be dissipated. Set parking brakes securely and open all necessary access doors. Check the hydraulic fluid level of the test stand reservoir. It should be three-fourths full, as indicated on the gauge. Add fluid if required. Check fuel gauge, radiator level, and engine oil level in engine-driven stands. Make sure that they are adequate for the anticipated operating period. Check the power connections in electric-powered stands for correct

Table 9-1.—A/M27T-5 Main Control Panel Controls and Indicators

FIG. 9-5 INDEX NO.	CONTROL/INDICATOR	FUNCTION
1	Panel light (DS1)	Provides main control panel lighting. Illuminates if ignition switch S1 is set to IGNITION ON.
2	AMMETER (MI-1)	Indicates charging condition of batteries B1 and B2. When discharging, indicates negative. When charging, indicates positive (-60 to +60 amp scale).
3	COLD WEATHER STARTING AID handle	Facilitates cold weather diesel engine starting. Handle pulling action is transmitted by sheathed cable to cold weather starting aid 6 cc valve lever. Ether is injected into diesel engine air inlet housing when handle is pushed back in.
4	START switch (S6)	When pressed, initiates diesel engine start sequence, if ignition switch S1 is set to IGNITION ON.
5	Diesel engine OIL PRESSURE gauge	Indicates diesel engine oil pressure (0 to 100 psi scale, 54 to 58 psi nominal from 2000 to 2500 rpm).
6	Fuse (F2)	Protects electrical circuits.
7	FLUID TEMP WARNING LIGHT (DS7)	Illuminates when hydraulic fluid temperature increases to trip setting (160°F) of fluid temperature thermo switch S5.
8	TACHOMETER/HOURMETER	TACHOMETER indicates diesel engine rpm (0 to 3500 rpm). HOURMETER (0.01 to 9999 hours) counts diesel engine revolutions in terms of time [indicates 0.1 hour (6 minutes) per 12318 revolutions].
9	EMERGENCY STOP handle	Used for emergency diesel engine shutdown. Handle pulling action is transmitted by sheathed cable to diesel engine air inlet housing shutdown valve lever.
10	PULL TO STOP/ENGINE STOP handle	Used for normal diesel engine shutdown. Handle pulling action is transmitted by sheathed cable to diesel engine variable speed closed linkage mechanical governor stop lever.
11	THROTTLE control handle	Handle pulling action is transmitted by sheathed cable to diesel engine variable speed closed linkage mechanical governor throttle lever.
12	Panel light (DS2)	Provides main control panel lighting. Illuminates if ignition switch S1 is set to IGNITION ON.
13	EMERGENCY STOP RESET handle	Used to open diesel engine air inlet housing shutdown valve after diesel engine emergency shutdown. Handle pulling action is transmitted by sheathed cable to valve lever.

Table 9-1.—A/M27T-5 Main Control Panel Controls and Indicators—Continued.

FIG. 9-5 INDEX NO.	CONTROL/INDICATOR	FUNCTION
14	PRESS OUTLET FLOWMETER	Indicates hydraulic fluid flow to high pressure port (2 to 30 gpm).
15	COMPENSATOR CONTROL	Adjusts pressure at which compensation occurs in high pressure pump when power supply is being used as a high pressure system.
16	PUMP CASE FILTER indicator (DS5)	Illuminates when pump case drain filter high differential pressure switch S3 closes. S3 will close if the pump case drain filter input and output pressure differ by 35 psi or more.
17	LOW PRESS FILTER indicator (DS6)	Illuminates when low pressure filter high differential pressure switch S4 closes. S4 will close if low pressure filter and inlet and outlet pressures differ by 50 psi or more.
18	COMPOUND GAUGE	Function depends on setting of PRESSURE SELECTOR VALVE (see 21, below). Calibrated to indicate 0 to 30 inches Hg vacuum and 0 to 300 psi.
19	Compound gauge calibration screw	Used to calibrate COMPOUND GAUGE when PRESSURE SELECTOR VALVE is set to CALIBRATE GAUGE.
20	L.P. GAUGE TEST port	Allows application of hydraulic fluid from external source for use in testing and calibrating COMPOUND GAUGE. Used only when PRESSURE SELECTOR VALVE is set to CALIBRATE GAUGE.
21	PRESSURE SELECTOR VALVE	4-position, 5-way valve. Acts as a hydraulic switch for connecting COMPOUND GAUGE to hydraulic pump or power supply return line. H.P. PUMP INLET and BOOST PUMP INLET settings connect COMPOUND GAUGE to hydraulic pump high pressure and boost pump inlets, respectively. RETURN BACK PRESSURE connects COMPOUND GAUGE to power supply return line. CALIBRATE GAUGE isolates COMPOUND GAUGE from hydraulic system enabling calibration of gauge.
22	Panel Light (DS3)	Provides main control panel lighting. Illuminates if ignition switch S1 is set to IGNITION ON.
23	PRESSURE BYPASS VALVE	When open, causes HIGH PRESSURE RELIEF VALVE to dump flow to return line at no pressure.
24	HIGH PRESS FILTER indicator (DS4)	Illuminates when high pressure filter high differential pressure switch S2 closes. S2 will close if high pressure filter inlet and outlet pressures differ by 100 psi or more.

Table 9-1.—A/M27T-5 Main Control Panel Controls and Indicators—Continued.

FIG. 9-5 INDEX NO.	CONTROL/INDICATOR	FUNCTION
25	H.P. GAUGE TEST port	Allows application of hydraulic fluid from external source for use in testing and calibrating HIGH PRESSURE GAUGE. Used only when H.P. GAUGE SHUTOFF VALVE (on secondary control panel) is closed.
26	High pressure gauge calibrating screw	Used to calibrate HIGH PRESSURE GAUGE when H.P. SHUTOFF valve (on secondary control panel) is closed.
27	HIGH PRESSURE GAUGE	Indicates hydraulic pressure (0 to 6000 psi scale) at PRESSURE OUTLET ports. closing H.P. GAUGE SHUTOFF valve (on secondary control panel) isolates HIGH PRESSURE GAUGE from hydraulic system, enabling testing and calibration of gauge.
28	FLUID TEMPERATURE GAUGE	Indicates hydraulic fluid temperature (20° to 220°F scale) at hydraulic pump high pressure inlet port.
29	Ignition switch S1	When set to IGNITION ON turns on panel lights DS1, DS2, and DS3 and IGNITION ON indicator DS9. Switches battery current to power supply electrical system, enabling diesel engine start-up.
30	IGNITION ON indicator (DS9)	When illuminated, indicates ignition switch S1 is set to IGNITION ON.
31	HEAD TEMPERATURE gauge	Indicates diesel engine coolant temperature (100° to 250°F scale).

Table 9-2.—Portable Hydraulic Test Stands

MODEL	MFR & P/N (CAGE)	PUBLICATION	MRC	TEC
A/M27T-5	Hydraulic International 88A4-J1000-1 (56529)	NA 17-15BF-89	17-600-127-6-1	GGJZ
A/M27T-7	68A5-J1000 (56529)	NA 17-15BF-91	17-600-150-6-1	GGJV
NOTES:				
1. A/M27T-5/-7 test stands are preferred equipment and shall be used whenever available.				
2. All electric motor-driven units operate from 220/440-V, 3-phase power source.				

phasing and frequency. Check the pointers of all other gauges; they should be at or near zero. Clean and connect the service ends of the external pressure and return line hoses to the hose storage (recirculation) manifold on the equipment. If the manifold is equipped with a shutoff valve, place the valve in open position.

Start test stand engine (or motor) according to the applicable operating instructions. Allow the engine to warm up to its normal operating temperature. Recirculation clean and deaerate the hydraulic fluid in the test stand. Perform both operations at the same time.

NOTE: When actually cleaning and deaerating the test stand, you should follow the procedures contained in the applicable manuals.

Set up the test stand to provide fluid flow from the internal reservoir through the external service hoses and interconnecting manifold. Place the pump pressure compensator at its lowest setting, and make sure that the manifold and service outlet valves (if present) are in the open position. The high-pressure gauge should indicate a value less than 600 psi. Allow the test stand to recirculation clean for 3 to 5 minutes. Monitor the fluid temperature throughout the cleaning cycle. Make sure that maximum operating limits are

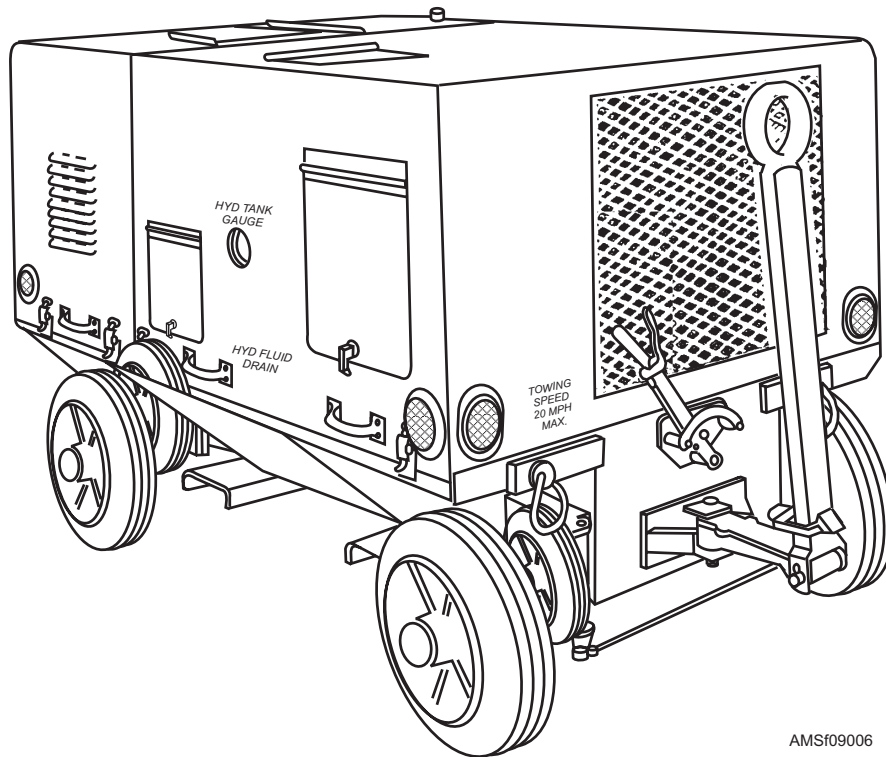

AMSF09006

Figure 9-6.—Portable electric motor-driven hydraulic power supply (A/M27T-7).

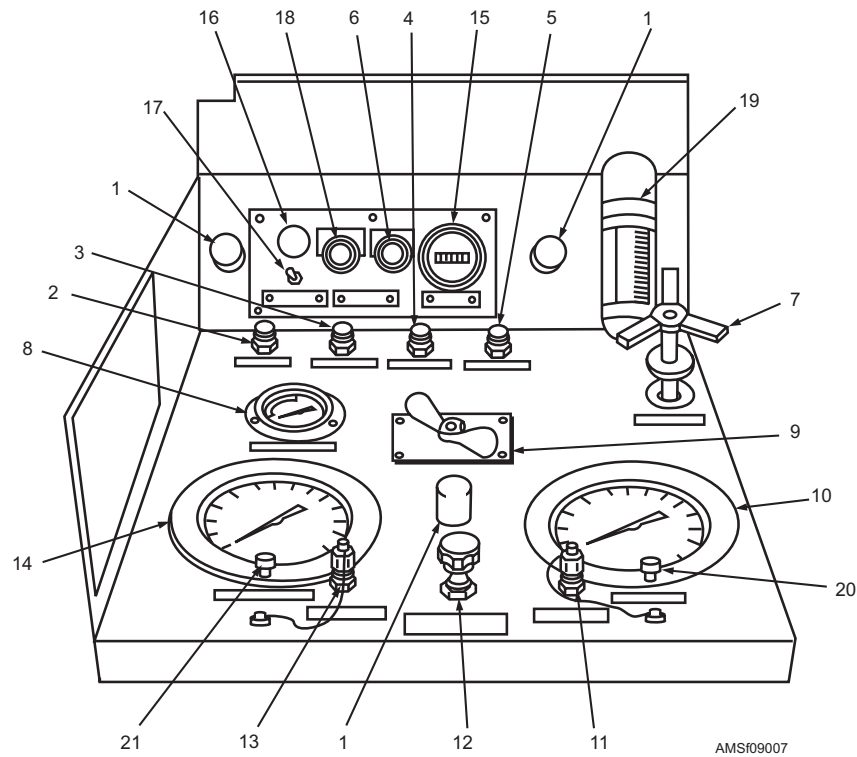

AMSF09007

Figure 9-7.—Primary control panel controls and indicators.

- | | | | |
|---|----------------------------|-----------------------------|---|
| 1. Panel lights | 6. Stop push-button switch | 11. L.P. gauge teat fitting | 16. Power on indicator light |
| 2. High-pressure filter indicator light | 7. Compensator control | 12. Pressure bypass valve | 17. Off-master-on switch |
| 3. Pump case filter indicator light | 8. Fluid temperature gauge | 13. H.P. gauge test fitting | 18. Start push-button switch |
| 4. Low-pressure filter indicator light | 9. Selector valve | 14. High-pressure gauge | 19. Pressure outlet flow meter |
| 5. Fluid temperature warning light | 10. Compound gauge | 15. Hour meter | 20. Compound gauge calibration screw |
| | | | 21. High-pressure gauge calibration screw |

Table 9-3.—Primary Control Panel Controls and Indicators

FIG. 9-7 INDEX NO.	CONTROL/INDICATOR	FUNCTION
1	Panel Lights (DS1, DS2, DS8)	Provide illumination for primary control panel light if OFF-MASTER-ON switch S1 is set to ON.
2	HIGH PRESSURE FILTER Indicator Light (DS4)	Lights when high pressure filter element requires service.
3	PUMP CASE FILTER Indicator Light (DS5)	Lights when pump case filter requires service.
4	LOW PRESSURE FILTER Indicator Light (DS6)	Lights when low pressure filter element requires servicing.
5	FLUID TEMP WARNING LIGHT (DS7)	Lights when hydraulic fluid temperature increases to +160°F (+71.11°C). This is trip setting of thermostwitch.
6	STOP Pushbutton Switch (S9)	Used to stop the electric motor.
7	COMPENSATOR CONTROL	Adjusts pressure at which compensation occurs in high pressure pump when power supply is used as a high pressure system.
8	FLUID TEMPERATURE GAUGE	Indicates temperature of hydraulic fluid going to inlet of high pressure pump.
9	SELECTOR VALVE	Provides selection of BOOST PUMP INLET, H.P. PUMP INLET, or RETURN BACK PRESSURE line readings on compound gauge; 4th position CALIBRATE GAUGE is for calibration of gauge.
10	COMPOUND GAUGE	Indicates (as selected by SELECTOR VALVE) back pressure or suction in low pressure return line, inlet to boost pump, and inlet to high pressure pump.
11	L.P. GAUGE TEST Fitting	Provides connection for external hydraulic source to calibrate COMPOUND GAUGE. SELECTOR VALVE must be in CALIBRATE GAUGE position.
12	PRESSURE BYPASS VALVE	When opened, cause high pressure relief valve to dump flow to return line at no pressure.
13	H.P. GAUGE TEST Fitting	Provides connection for external hydraulic source to test and calibrate HIGH PRESSURE GAUGE. SELECTOR VALVE must be in CALIBRATE GAUGE position.
14	HIGH PRESSURE GAUGE	Indicates hydraulic fluid pressure at PRESSURE OUTLET ports.
15	HOURLMETER	Indicates total elapsed operating hours of power supply.
16	POWER ON Indicator Light	Lights when control circuit is energized and MASTER switch is placed to ON.
17	OFF-MASTER-ON Switch (S1)	Energizes electrical control circuits.
18	START Pushbutton Switch (S10)	Starts electric drive motor
19	PRESSURE OUTLET Flow Meter	Indicates hydraulic fluid flow (in gallons per minute) to PRESSURE OUTLET ports.
20	COMPOUND GAUGE Calibration Screw	Used to calibrate COMPOUND GAUGE when SELECTOR VALVE is in CALIBRATE GAUGE position.
21	HIGH PRESSURE GAUGE Calibration Screw	Used to calibrate HIGH PRESSURE GAUGE when SELECTOR VALVE is in CALIBRATE GAUGE position.

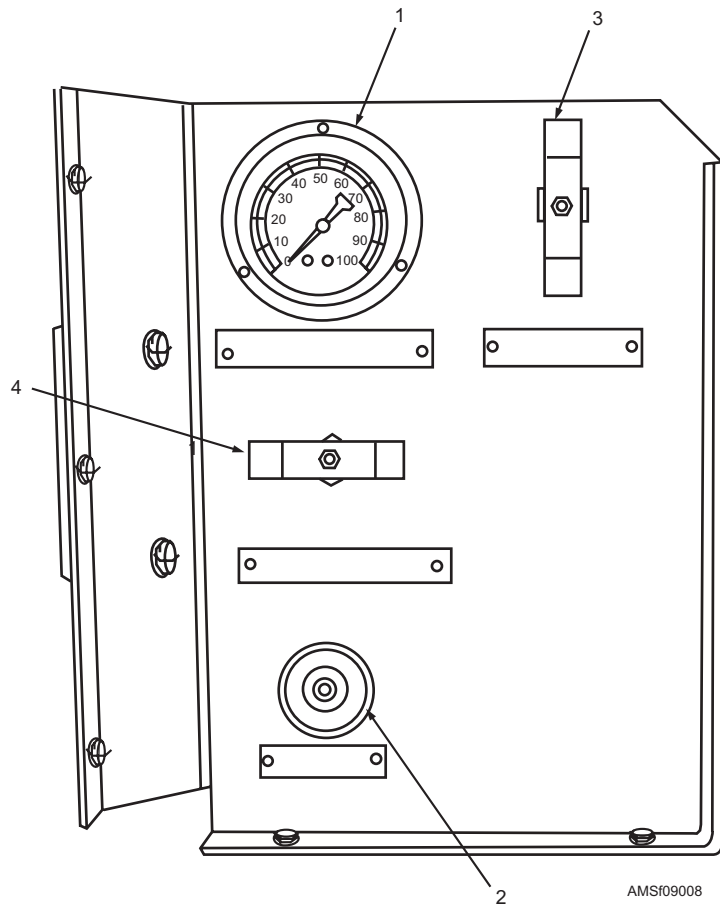

Figure 9-8.—Secondary control panel controls and indicators.

1. Aircraft fill system pressure gauge
2. Aircraft fill system relief valve
3. High-pressure gauge shutoff
4. Aircraft fill system shutoff valve

Table 9-4.—Secondary Control Panel Controls and Indicators

FIG. 9-8 INDEX NO.	CONTROL/INDICATOR	FUNCTION
1	AIRCRAFT FILL SYSTEM PRESSURE GAUGE	Indicates hydraulic pressure at AIRCRAFT FILL SYSTEM OUTLET Port, when AIRCRAFT FILL SYSTEM SHUTOFF valve is open.
2	AIRCRAFT FILL SYSTEM RELIEF VALVE	Used to manually adjust fill system pressure and provide system pressure relief.
3	HIGH PRESSURE GAUGE SHUT OFF	When closed, isolates HIGH PRESSURE GAUGE for calibration or service. Also acts as pulsation snubber.
4	AIRCRAFT FILL SYSTEM SHUTOFF VALVE	Used to shut off or turn on the flow through the fill hose.

not exceeded. Monitor all filter differential pressure indicators, particularly those associated with the 3-micron filter assemblies. If you see an indication of a loaded filter after the fluid reaches normal operating

temperature (85°F minimum), shut down the test stand and have replacement filter elements installed. On test stands that have a fluid sight glass and manual air bleed valve, periodically operate the valve and monitor the

sight glass throughout the cleaning cycle to eliminate visible indications of entrapped air.

When recirculation cleaning and deaeration are complete, analyze the hydraulic fluid for contamination. Terminate the fluid flow to the external service hoses in preparation for connecting them to the aircraft. Disconnect the service hoses from manifold assembly and reinstall the manifold dust covers.

Applying Hydraulic Power

Before you connect a test stand to an aircraft system, make sure that all personnel, workstands, and other ground-handling equipment are clear of flight control surfaces, movable doors, and other units. Stay clear of these areas when either electric power or hydraulic pressure is applied to the aircraft. Sudden movement can cause injury or damage.

NOTE: Refer to the applicable maintenance manual for the specific procedures to follow when applying external electric and hydraulic power.

Before connecting the hydraulic test stand to the aircraft, set the test stand controls to the positions and values required to accomplish the aircraft tests. Operate the test stand to confirm the settings. Reduce the volume adjustment to minimum flow and shut down the stand. Connect the test service hoses to the aircraft ground power quick-disconnects, making sure that all connectors are clean before connection. Mate all the attached dust caps and plugs to protect against their contamination during test stand operation.

Do not kink or damage the test stand hose when connecting it to an aircraft system. Keep the hose uniformly bent while bending around structures or equipment. Maintain and follow the recommended minimum inside bend radius for the hose. A 1/2-inch pressure hose should have a 2.30-inch radius, a 5/8-inch pressure hose a 5.37-inch radius, and a 1-inch hose a 5.90-inch radius.

Before you can apply hydraulic power, you need to check the aircraft reservoir level. Fill it to the level specified in the applicable MIM or MRC. If necessary, service the reservoir using an approved fluid service unit. Then, set up the test stand for either aircraft or test stand reservoir operation, as specified in the applicable MIM. You can set the required mode of operation by using the reservoir selector valve on stands that have this equipment, or use the reservoir fluid supply valve. When the test stand reservoir supply valve is closed, the aircraft reservoir will operate. The test stand

reservoir is preferred because the vented reservoir allows aircraft fluid deaeration during system operation (fig. 9-9). Use this mode whenever practical.

When a test stand is equipped with return line, back pressure reducing valves, test stand reservoir operation can be used even in situations where the aircraft reservoir is normally used. Adjust the back pressure reducing valve by presetting the value equivalent to normal aircraft reservoir pressure.

Make sure that the aircraft controls are in the specified ground check positions required for obtaining normal reservoir fluid level. Apply external hydraulic power and trim the back pressure reducing valve until a stable, proper fluid level is obtained in the aircraft reservoir. Periodically check the fluid level. Ensure back pressure reducing valve is set properly or the aircraft may be damaged by overpressurization.

After you have adjusted the back pressure reducing valve, you can start the test stand, and allow it to warm up with the controls set for bypass fluid flow. Adjust the flow rate and operating pressures to the required values using the volume and pump compensator controls. Set the emergency relief valve (if so equipped) to the operating pressure, plus 10 percent. The bypass control should be fully closed during aircraft operation. **Adjust the operating pressure using the pump compensator control only.** The test stand is now ready to power the aircraft hydraulic system.

NOTE: Use the procedures found in the applicable MIM to actually power the aircraft hydraulic system.

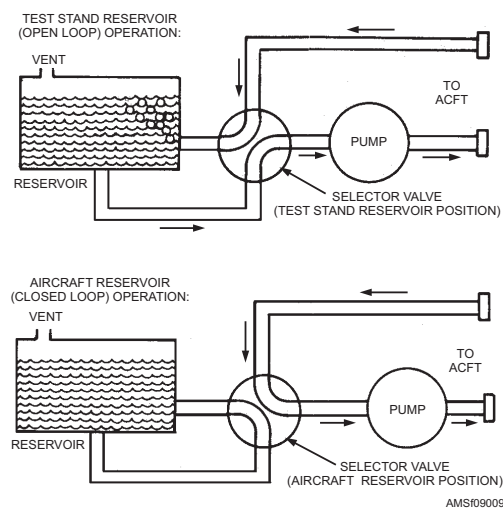

Figure 9-9.—Test stand operating modes.

Operational Checks

When operating the test stand, you need to periodically check the condition of system fluid through the sight glass. If you see evidence of air, bleed the system at both the test stand and air bleed points in the aircraft until the fluid appears clear. Also, you need to monitor the filter differential pressure indicators, particularly those associated with the 3-micron filter assemblies. In some cases, loaded filter indicators may extend due to cold starting conditions. Reset the indicator and continue to monitor it until the equipment reaches the normal operating temperature. If a loaded filter is indicated, shut down the equipment and return it to the supporting activity. Another condition that would require you to return the equipment to the supporting activity is if the fault indicators light; in this case, shut down the unit and return it to the supporting activity. In case of an emergency (for example, a ruptured hydraulic hose in aircraft), you should open the bypass valve to relieve pressure and stop the flow of hydraulic fluid to the aircraft. Pay attention to warning signs, such as a sudden drop in engine oil pressure or any unusual engine noise. If any engine part fails, **stop the engine immediately**.

Shutdown Procedures

In aircraft equipped with pressurized reservoirs, hydraulic accumulators, or surge dampers, a reverse flow of fluid through the aircraft filters could damage the system. You need to use the correct shutdown procedures. When you have finished the required aircraft tests, leave the bypass valve in the closed position. Reduce the volume setting to zero and adjust the pressure compensator to minimum. Allow several minutes for stored pressure in the aircraft to bleed off, via normal internal leakage. On stands equipped with a pressure and return line shutoff valve, close the valve instead of reducing the volume and pressure compensator.

Slowly open the pressure bypass valve. Let the engine run at 1,000 rpm for about 5 minutes (engine-driven models only), then push the throttle down completely. Place the panel light switch in the OFF position. Remove the external hoses from the aircraft hose ports. Connect one end to the hose storage manifold disconnects on the test stand. Do not drag the hose ends on the deck or expose them to contamination. Install all dust caps and plugs,

including those at the aircraft quick disconnects. Close all the access doors to protect instruments and controls.

Multisystem Operation

When performing troubleshooting, rigging, and specific tests on dual flight control systems that have tandem actuators, you often need to apply SE hydraulic pressure to two or three systems in an aircraft at the same time. Simultaneous, multisystem operation involves using separate hydraulic test stands for each system, or by manifolding two or more systems to a common test stand that has a sufficient flow capability. Less equipment is needed with the latter method, but it has several limitations that you should know.

If you use a single test stand and manifold, hydraulic fluid between the connected systems is exchanged. If the fluid in one system is contaminated with particulate matter smaller than 3 microns, cross-contamination of the other system(s) will occur. Using a single test stand may not satisfy differing flow and back pressure requirements of the multiple systems to be powered. Depleting or overfilling aircraft reservoirs might result. If a single test stand is used, high transient flow demands in one system could adversely affect the performance of the other systems. Total isolation between systems could possibly degrade critical flight control system performance tests. The use of jury-rigged manifolds not specifically engineered for the purpose is a safety hazard to personnel and a possible source of system contamination. Properly designed hydraulic manifolds can be used in limited, specific applications to power multiple hydraulic systems to form a common hydraulic test stand. This configuration must be evaluated by the cognizant engineering activity to make sure it is acceptable and that its use is strictly limited to that particular application. All approved manifold use must be directed in the applicable aircraft MIM, and complete information on the source of the required hardware must be provided. **Do not use manifolds that are not authorized.**

- Q9-10. What is the purpose of a portable hydraulic test stand?*
- Q9-11. What is the power source of the A/M27T-5 portable hydraulic power supply unit?*
- Q9-12. What is the purpose of the emergency stop handle on the A/M27T-5 unit?*
- Q9-13. What is the range of the high-pressure gauge on the A/M27T-5 unit?*

- Q9-14. What is the main difference between the A/M27T-5 unit and the A/M27T-7 unit?*
- Q9-15. What publication supplies detailed information on the A/M27T-7 unit?*
- Q9-16. At what level should the reservoir of a hydraulic test stand be maintained?*
- Q9-17. After you start a hydraulic test stand, what is the first thing you must do?*
- Q9-18. What actions must be taken prior to connecting a hydraulic test stand to an aircraft?*
- Q9-19. Once you have the hoses connected to the aircraft, what action must you take prior to applying hydraulic power to an aircraft?*
- Q9-20. What component is used to adjust the operating pressure of a hydraulic test stand?*

STATIONARY HYDRAULIC TEST STANDS

Stationary hydraulic test stands are permanently installed equipment used for shop-testing hydraulic system components. Except for specialized equipment, such as hose burst test stands, they are general-purpose equipment capable of performing a variety of tests on components such as hydraulic pumps, actuators, motors, valves, accumulators, and gauges. Typical component test stands consist of adjustable sources of hydraulic and shaft-driven (for pump drive) power, with associated regulator and indicating devices that let you monitor performance under simulated operating conditions. Stationary hydraulic test stands are used at the intermediate-maintenance level, ashore and afloat, and for depot-level maintenance.

Model HCT-10 Stationary Hydraulic Test Stand

Stationary hydraulic test stands, such as the Model HCT-10, are not part of the equipment allowance for most squadrons. Normally, they are issued to air stations and aircraft carriers for use by the supported squadrons.

NOTE: The following information is for training purposes only. Do not use it as operating instructions for testing hydraulic or pneumatic components. For specific operating instructions, you should refer to the applicable operational handbook, service, and overhaul instructions, or the MIM.

The Model HCT-10 test stand (fig. 9-10) is used to bench test aircraft hydraulic and pneumatic components, such as engine-driven hydraulic pumps, electro hydraulic flight control assemblies, double-acting hydraulic cylinders, pneumatic and hydraulic relief valves, hydro pneumatic accumulators, and other components.

The test stand consists of a nonportable cabinet assembly that contains a hydraulic system, a pneumatic system, and an electrical system. It must be connected to externally supplied electrical power, water, and compressed air. The cabinet assembly consists of a welded steel enclosure on a rigid base. Hinged doors and removable panels provide access to the interior. The test component work area is located below the center instrument and control panel. The bottom surface of the test component work area and the test chamber is shaped like a sink with perforated metal trays. The test chamber is made from a 1/4-inch steel plate with a hinged door containing a safety-type window.

Most of the hydraulic and pneumatic system operating controls are located on a sloping panel along the front of the cabinet. The indicators are located on a panel above the work sink and the rear panel of the test chamber. The electrical system controls and indicators are located on a panel on the right-hand side of the cabinet. A partition separates the major part of the electrical system components from the hydraulic system.

HYDRAULIC SYSTEM.—The hydraulic system has two components—a reservoir, which supplies fluid through a helical, screw-type boost pump, and a filter to a variable volume, pressure-compensated, axial piston, high-pressure pump. Also, the hydraulic system has three circuits—the dynamic test circuit, the static test circuit, and the pump test circuit.

Dynamic Test Circuit.—The dynamic test circuit is used to test double-acting hydraulic cylinders and other components requiring combined pressure and flow.

Static Test Circuit.—The static test circuit is included in the hydraulic system. It is essentially a compressed air-operated, low-displacement, high-pressure pump that supplies fluid for static pressure tests. This circuit may be operated independently of the other two test circuits. A safety interlock prevents operation of this circuit when the door of the test chamber is open.

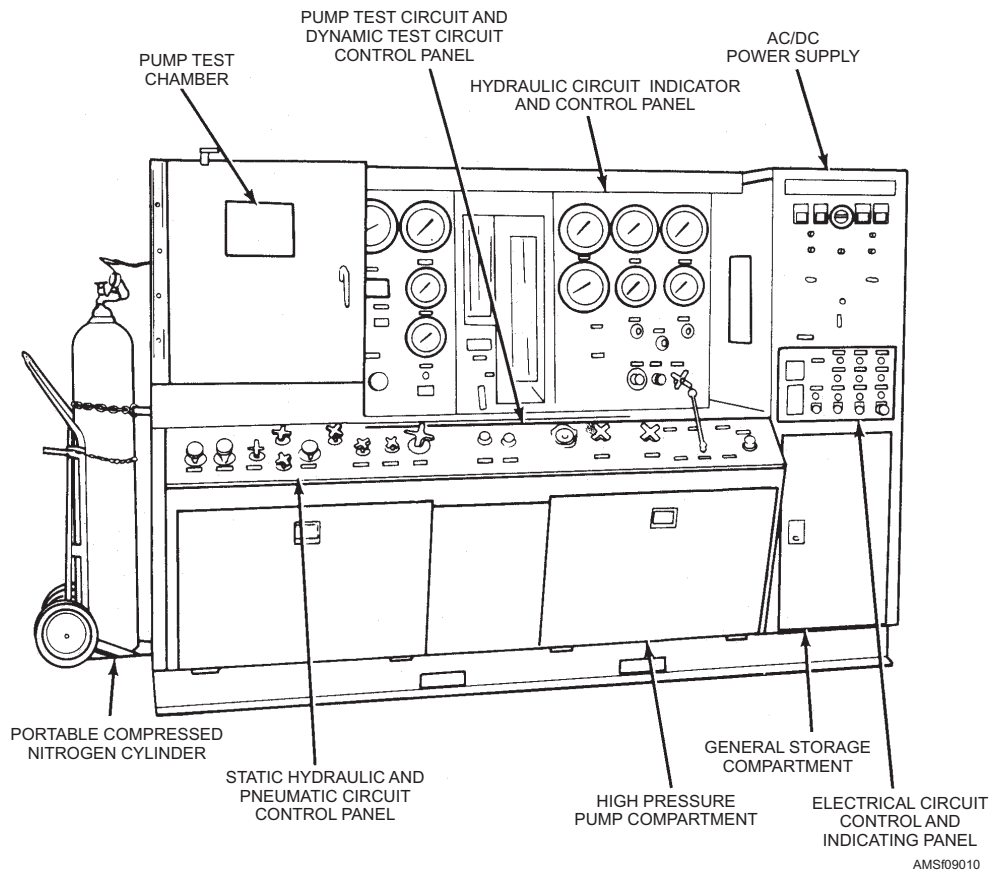

Figure 9-10.—Model HCT-10 hydraulic and pneumatic component test stand.

Pump Test Circuit.—The pump test circuit supplies controlled pressure and flow to a variable-displacement, reversible-rotation, hydraulic motor that, in turn, supplies power for driving hydraulic pumps during tests.

PNEUMATIC SYSTEM.—The pneumatic system is composed of two circuits. One circuit provides control, indication, and filtration of externally supplied compressed air for the operation of the hydraulic fluid temperature control system, the hydraulic static pressure pump, and the pneumatic static pressure booster. The second circuit consists of a portable, compressed nitrogen cylinder that supplies gas to a supply port through a manually adjusted pressure regulator for static pneumatic testing. A safety interlock prevents operation of this circuit when the door of the test chamber is open.

ELECTRICAL SYSTEM.—Externally supplied electrical power is controlled by a system located on the right-hand control panel. The test stand START switch, pump ON/OFF switches, and a test stand STOP switch are located along the lower portion of this panel. There is also a test stand STOP switch on the top left side on the front of the test stand.

- Q9-21. What is the purpose of a stationary hydraulic test stand?
- Q9-22. Stationary hydraulic test stands are used at what levels of maintenance?
- Q9-23. Other than hydraulic components, what other types of components can be tested on the HCT-10?
- Q9-24. What three things must be externally connected to the HCT-10 unit for it to operate?
- Q9-25. How many different test circuits does the HCT-10 unit have?
- Q9-26. What test circuit is used to test double-acting hydraulic cylinders?
- Q9-27. What component on the HCT-10 prevents operation when the door of the test chamber is open?

CONTAMINATION CONTROL OF SUPPORT EQUIPMENT

LEARNING OBJECTIVE: Recognize the contamination control requirements for support equipment.

The direct connection between hydraulic SE and the systems or components being checked or serviced is necessary to minimize the introduction of external contaminants. Test units that are not properly configured, maintained, or used may severely contaminate hydraulic systems in operational aircraft. It is your responsibility to make sure that hydraulic SE is maintained and used according to existing contamination control requirements.

CONFIGURATION

All support equipment used to service or test aircraft hydraulic systems or components is equipped with adequate output filtration that has a rating of 3 microns (absolute). The 3-micron filter assembly is a nonbypass variety, preferably equipped with a differential pressure indicator. It is installed immediately upstream of the major fluid discharge ports.

Portable hydraulic test stands are equipped with recirculation cleaning manifolds and fluid sample valves for self-cleaning and fluid analysis before they are connected to equipment under test.

CLEANLINESS

Hydraulic SE is maintained in a clean state. All hydraulic SE is maintained as clean as practicable, consistent with its construction and use. Always keep external fluid connections, fittings, and openings clean and free of contamination. When not in use, protect fittings or hose ends using metal dust caps or other approved closures. You can use clean, polyethylene bags if you do not have the approved metal closures, providing the bags are adequately secured and are protected from physical damage and the entrance of water. When equipment is not being used, store it in clean, dry areas. Minimize exposure of in-service equipment to precipitation, wind-driven sand, or other environmental contaminants.

AIR BLEEDING

Air bleeding is a service operation. In this operation, entrapped air is allowed to escape from a closed hydraulic system. For specific air bleed procedures for each model aircraft, you should refer to the applicable MIM. Excessive amounts of free or entrained air in an operating hydraulic system results in degraded performance, chemical deterioration of fluid, and premature failure of components. Therefore, when a component is replaced or a

hydraulic system is opened for repairs, the hydraulic system must be bled of air to the maximum extent possible upon repair completion.

Hydraulic fluid can hold large amounts of air in solution. Fluid, as received, may contain dissolved air or gasses equivalent to 6.5 percent by volume, which may rise to as high as 10 percent after pumping. Dissolved air generates no problem in hydraulic systems so long as it stays dissolved, but when it comes out of solution (as extremely minute bubbles), it becomes entrained or free air. Free air could enter a system during component installation, filter element installation, or opening the system during repairs.

Free air is harmful to hydraulic system performance. The compressibility of air acts as a soft spring in series with the stiff spring of the oil column in actuators or tubing, resulting in degraded response. Also, because free air can enter fluid at a very high rate, the rapid collapse of bubbles may generate extremely high local fluid velocities that can be converted into impact pressures. This is the phenomenon known as cavitation. Cavitation causes pump pistons and slide valve metering lands to wear rapidly, commonly causing component failure.

Any maintenance operation that involves breaking into the hydraulic system introduces air into the system. The amount of such air can be minimized by prefilling replacement components with new, filtered hydraulic fluid. Because some residual air may still be introduced, all maintenance of this type is followed by a thorough air bleed of the system. Most hydraulic systems in high-performance aircraft are of the closed, airless type; they are designed to self-scavenge free air back to the system reservoir. Air bleed valves are provided at the reservoir to remove this air. Because free air resulting from maintenance actions or other causes may enter the system at a point remote from the system reservoir, the system should be extensively cycled with full power to transfer air to the reservoir, where it can be bled off.

Air bleed valves are sometimes found at high points in the aircraft circulatory system, filter assemblies, and remote system components such as actuators. These valves make the removal of free air easier. Refer to the applicable MIMs for the location and use of additional bleed points. In systems not equipped with additional bleed points, you may have to loosen line connections temporarily at strategic points in the system, which permits removal of entrapped air from remote or dead-end points. When you bleed a system in this manner, be careful to avoid excessive

loss of hydraulic fluid, and prevent the induction of air or contaminants into the system.

In many cases, air inspection procedures are inadequate. Support equipment specifically designed to detect and measure air is not presently available in the fleet. You should use indirect methods to determine the amount of air present in a system. Operating the air bleed valve on the reservoir reveals whether or not there is air present in the reservoir. Large amounts of air might be present somewhere else in the system and go undetected. An effective means for measuring the air in your system is known as the *reservoir sink* check. In this method, the fluid level in the aircraft reservoir is checked with the system, both pressurized and nonpressurized. The presence of air or any compressible gas in the system causes the pressurized reading to be lower (reservoir sink), indicating the need for possible maintenance action (fig. 9-11). This check is particularly effective when performed after a long aircraft *down* period, in which case dissolved air has had lots of time to come out of solution.

All air bleed operations must be followed by a check of the system hydraulic fluid level. Fluid replenishment may be required, depending upon the amount of air and fluid purged from the system.

OPERATIONAL USE

Operate test stands equipped with hydraulic manifolds for self-recirculation cleaning before they are connected to equipment or components under test. Recirculation clean the test stand for a sufficient period of time to let a minimum of one pass of its total reservoir contents through the internal filtration. Closely monitor differential pressure of *loaded filter* indicators during all SE operations after the fluid reaches normal operating temperature (+85°F minimum). Equipment operation is terminated immediately upon appearance of loaded filter indications. Replace the loaded element. You should stop using the SE if the reservoir or outlet fluid is, or is suspected to be, unacceptably contaminated. Inform the supporting maintenance activity immediately so that required remedial action can be taken.

PERIODIC MAINTENANCE

Supporting activities for hydraulic SE perform periodic maintenance at prescribed intervals, unless otherwise directed. At this time, samples are taken from all hydraulic SE reservoirs (preferably at a low

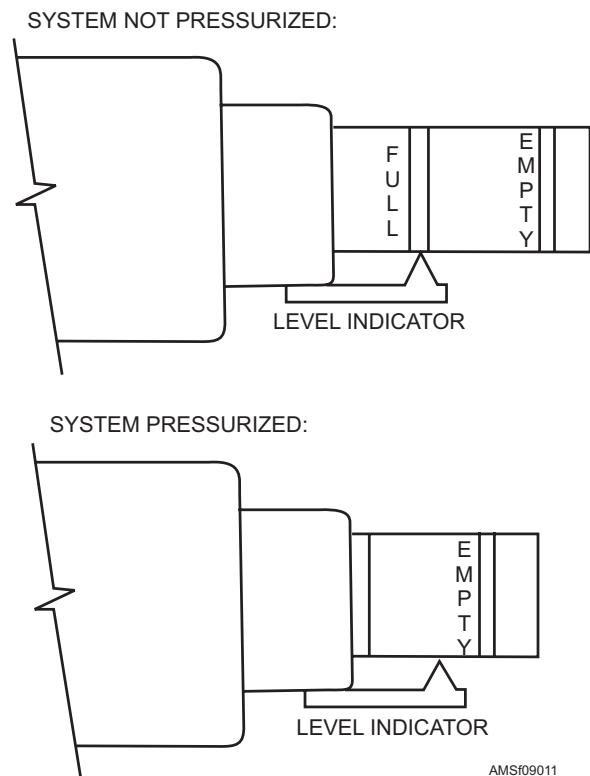

Figure 9-11.—Reservoir level changes (reservoir sink) presence of air in system.

point drain) and analyzed for particulate level and water content. If the fluid is unacceptable, it is recirculation cleaned, purified, flushed, or purged. Hydraulic filter elements that can be cleaned are ultrasonically cleaned or replaced at the prescribed maintenance interval. Because of their large dirt-holding capacity, disposable 3-micron pressure line filters are replaced only upon actuation of their differential pressure indicators. Disposable filters that do not have differential pressure indicators are replaced at the prescribed interval.

Age-controlled, deteriorative hoses used to carry hydraulic fluid in SE units are not to remain in service for more than 7 years beyond the manufacturer's cure date. Additionally, hoses of this type that are internally located in the equipment are replaced at each prescribed major rework interval, not to exceed 4 years. The date of the required removal and serial number of the equipment is etched or peened on the hose collar. Replace external deteriorative hoses used to transfer fluid between SE and aircraft or components under test that cannot be positively identified as having been in use for less than 2 years as soon as possible, and at regular intervals thereafter, not to exceed 2 years. The date of required replacement and the SE serial number is etched or peened on the hose collars. Hoses should remain attached to the

equipment until replacement is required. Upon completion of periodic maintenance, hydraulic SE is certified as having a fluid contamination level not in excess of Navy Standard Class 3.

Fluid Sampling

Fluid sampling points and procedures vary with the SE type and model. For specific procedures applicable to the particular equipment, you should refer to NAVAIR 01-1A-17. Run the SE for a minimum of 5 minutes before you take a sample. This results in fluid flow through SE reservoirs, which ensures a uniform distribution of contaminants. On some SE models, you need the return pressure outlet to the reservoir fill opening to achieve such a flow. Find and gain access to the reservoir drain valve and other sampling points and adapters. You need to remove dirt and other visible contaminants from the exposed part of the drain valve and /or sampling adapter. When taking a sample for a patch or particulate patch test, wipe the valve or adapter with a clean, disposable cloth. Use the plastic wash bottle in the Contamination Analysis Kit 571414 to flush the fittings with clean MIL-PRF-680.

When you have finished flushing the fittings, open the reservoir drain valve and allow approximately 1 quart of fluid into a waste receptacle. Without interrupting the flow of fluid, take the required sample by letting an additional 4 ounces of fluid flow into a clean sample bottle (provided with the contamination analysis kit). Close the drain valve after you remove the sample bottle from the fluid stream. Label the bottle to indicate where you took the sample. Repeat the sample-taking procedure at other specific or available sampling points, collecting each sample in a separate bottle. Visually inspect the fluid collected in the waste receptacle for free water. If free water is seen, decontaminate the system according to applicable procedures.

Decontamination

Decontamination of unacceptable SE equipment is performed by recirculation cleaning, purifying, flushing, or purging, as required; these actions are performed by the supporting activity.

RECIRCULATION CLEANING.—Recirculation cleaning is used when equipment is unacceptably contaminated with particulate matter (in excess of Navy Standard Class 3), but the fluid is otherwise considered satisfactory. In recirculation cleaning, the equipment is self-cleaned using its

internal filters, the 3-micron elements in particular. You begin by operating the contaminated SE so maximum circulation of fluid through the equipment reservoir and internal 3-micron filters occurs. Maintain the flow long enough to allow a total flow equivalent to at least five times the total fluid capacity of the equipment reservoir. Monitor all filter differential-pressure indicators throughout the operation. If elements appear to be loaded, check and replace them.

You should resample and analyze the fluid from the reservoir. If improvement is shown, but the contamination level is still excessive, repeat the process. If there is still no improvement, try to find the internal contamination source, such as a failed component. Replace any components you determine to be contaminating the fluid, and continue decontamination by draining, flushing, and refilling the equipment with new filtered fluid. Recirculation clean and resample, as before, to determine acceptability. When you find the fluid samples from the reservoir to be within acceptable limits, recirculation cleaning may be terminated.

PURIFYING.—Purification is the process of removing air, water, solid particles, and solvents from hydraulic fluids. A schematic of a typical commercially available purifier, P/N AD-A352-8Y17, P/N PE-00440-1H or equivalent, is illustrated in figure 9-12. Contaminated fluid going to the purifier tower is first filtered by a 25-micron (absolute) filter. The vacuum applied to the tower removes air and water from the contaminated fluid. As the fluid comes out of the tower, it is filtered through a 3-micron (absolute) filter to remove solid particles. This cycle is repeated until a desired level of cleanliness is attained. For support equipment contaminated with air and water, the use of a purifier to clean the equipment will reduce the consumption of oil and replace the need for flushing.

FLUSHING.—Flushing is used to decontaminate support equipment that is heavily contaminated with particulate matter, or when the fluid contains a substance not readily removed by the internal filters. To begin the flushing procedure, you drain, flush, and reservice the equipment reservoir using new filtered fluid. If the contamination originated at the pump, drain and flush the hoses and lines directly associated with the pump output separately.

Operate the equipment so fluid flows through all circuits. Allow output (or return line) fluid to dump overboard into a waste receptacle. Continue flushing

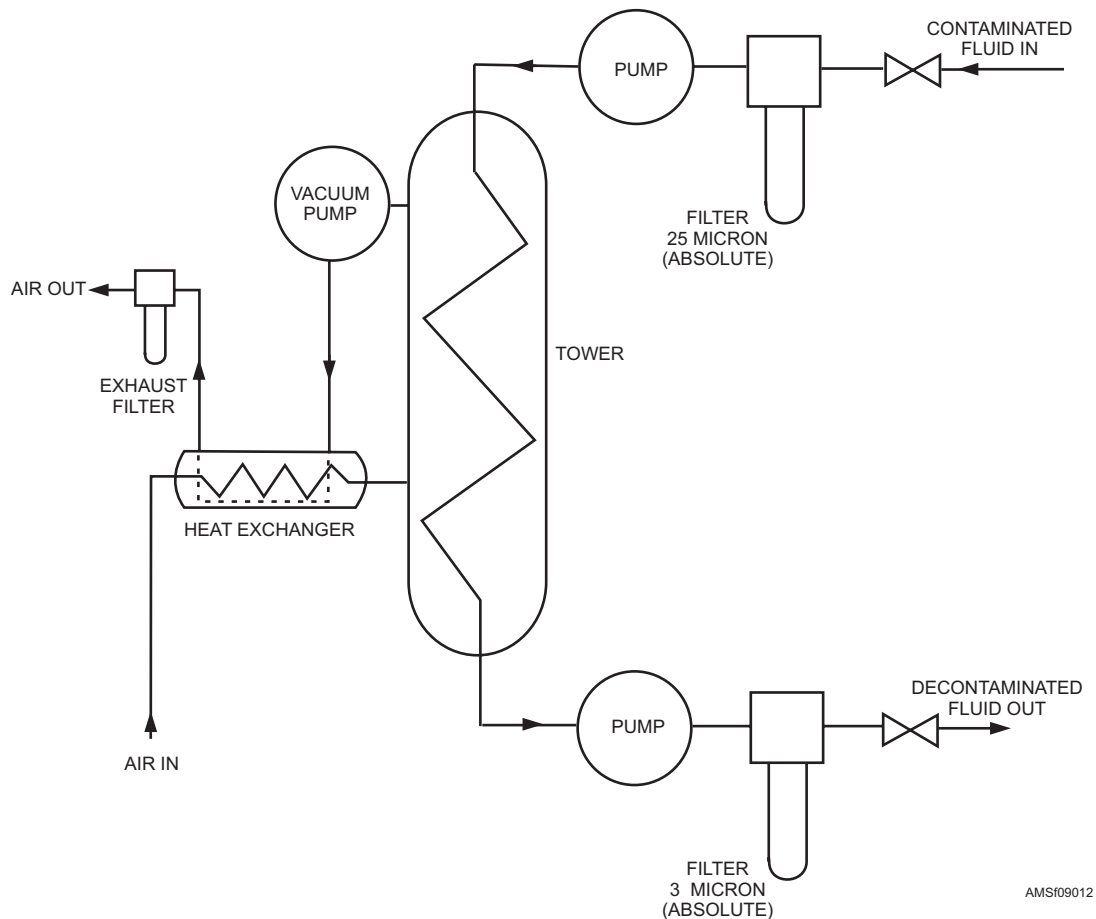

Figure 9-12.—Fluid purification system.

until a quantity of fluid equal to the equipment reservoir capacity has passed through the unit. Closely monitor the reservoir level during the operation, adding new filtered fluid as required. This prevents the reservoir level from dropping below the one-third full point.

Take a sample and analyze the output and the reservoir fluids. If the contamination level shows improvement but is still unacceptable, repeat the flushing operation. If extensive flushing fails to decontaminate the equipment, you should request assistance from the supporting engineering activity.

Upon successful completion of system flushing, recirculation clean the equipment for a minimum period. Then, take a sample from the system to verify the contamination level as being acceptable. When you have done this, service the reservoir.

PURGING.—Purging of a support equipment hydraulic system is performed only upon recommendation from, and under the direct supervision of, the cognizant engineering activity. It is the responsibility of the cognizant engineering activity to select the required cleaning agents, provide detailed

cleaning procedures, and perform tests upon completion of purging to ensure satisfactory removal of all cleaning agents. Whenever possible, purging operations are to be accomplished at a naval aviation depot facility (NADEP). Intermediate maintenance activities are not authorized to perform system purging without direct depot supervision.

- Q9-28. Where is the nonbypass filter installed on a support equipment unit used to test or service an aircraft hydraulic system?
- Q9-29. What can be used in place of an approved metal closure to protect fittings on a hydraulic test stand?
- Q9-30. What is the purpose of air bleeding a piece of hydraulic support equipment?
- Q9-31. What is one method used to keep air from being introduced into a hydraulic system when you are replacing a component?
- Q9-32. What function must be accomplished prior to connecting a test stand to an aircraft?
- Q9-33. What cleaner is used to clean all sampling points on a hydraulic test stand?

- Q9-34. How much fluid must you drain from a hydraulic test stand before you can take a sample?*
- Q9-35. How many different methods are there for decontaminating a hydraulic system?*
- Q9-36. What size filter does the hydraulic fluid pass through before entering the purifier tower during purification cleaning?*

- Q9-37. What decontamination method would you use for support equipment that is heavily contaminated with particulate matter?*
- Q9-38. What decontamination method is NOT authorized at organizational and intermediate level maintenance?*

CHAPTER 10

HOSE AND TUBING FABRICATION AND MAINTENANCE

INTRODUCTION

You are responsible for maintaining a portion of the hundreds of feet of fluid and air lines and various hardware and seals found in modern-day aircraft. The maintenance of these lines frequently involves fabrication and replacement of hose/tubing assemblies. To be able to select the proper type of hose and tubing and their hardware, you will need a basic knowledge of the type, size, and material from which items are to be made. Hose and tubing assemblies are used to transport liquids or gas (usually under pressure) between various components of the aircraft system. Hose and tube assemblies are used in aircraft for fuel, oil, oxidizer, coolant, breathing oxygen, instruments, hydraulic, and vent lines. You must be familiar with the procedures for testing and fabricating hose and tubing assemblies, and you must recognize the various tools and equipment and how to identify the different uses of hose and tubing in naval aircraft.

HOSE AND HOSE ASSEMBLIES

LEARNING OBJECTIVES: Identify the various types of hose and hose assemblies. Identify hardware, tools, equipment, maintenance practices, and age control requirements for naval aircraft. Recognize maintenance practices for hose and hose assemblies.

Hose assemblies are used to connect moving parts with stationary parts and in locations subject to severe vibration. Hose assemblies are heavier than aluminum-alloy tubing and deteriorate more rapidly. They are used only when absolutely necessary. Hose assemblies are made up of hose and hose fittings. A hose consists of multiple layers of various materials. An example of the hose most often used in medium-pressure applications is shown in figure 10-1.

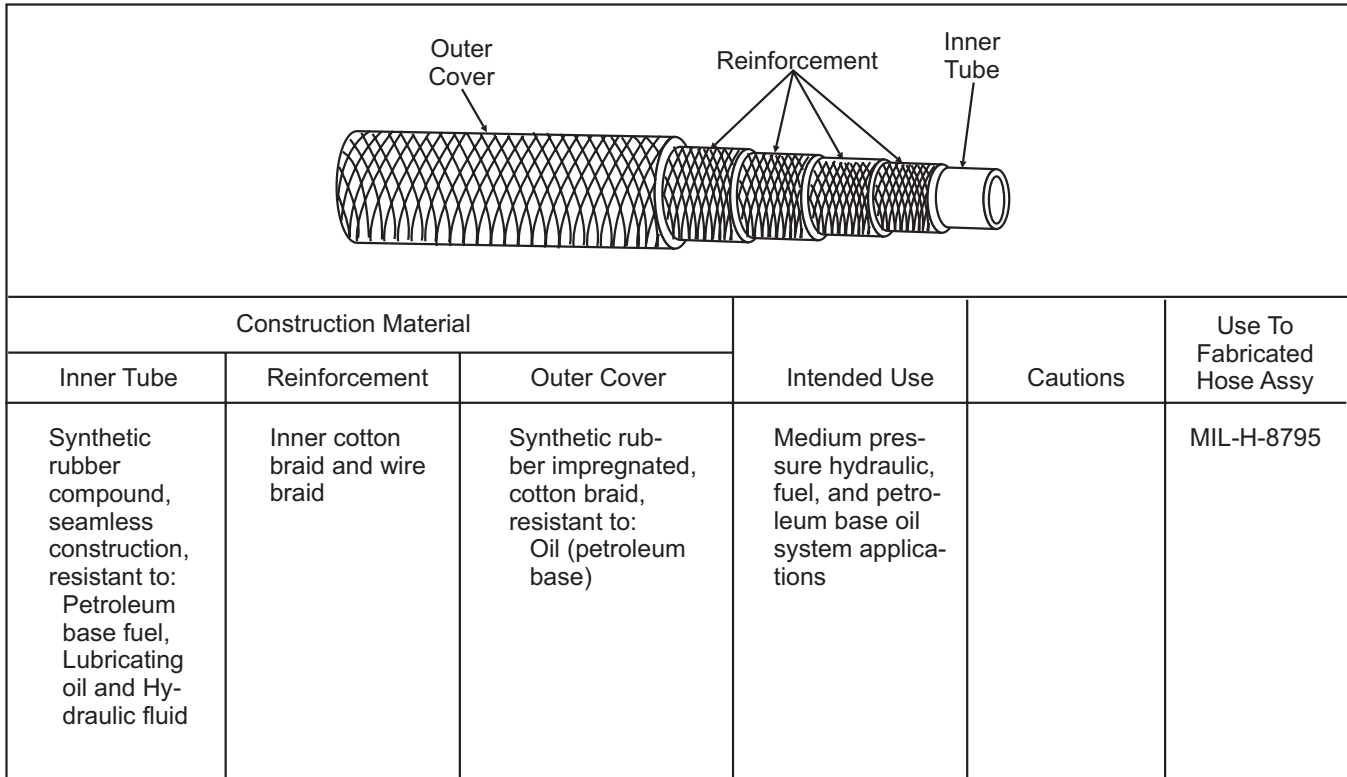

AMf10001

Figure 10-1.—Medium pressure synthetic rubber hose, MIL-H-8794.

TYPES OF HOSE

There are two basic types of hose used in military aircraft and related equipment. They are synthetic rubber and polytetrafluoroethylene, commonly known as Teflon® or PTFE.

Synthetic Rubber Hose

Synthetic rubber hose has a seamless synthetic rubber inner tube covered with layers of cotton and wire braid, and an outer layer of rubber impregnated cotton braid. The hose is provided in low-, medium-, and high-pressure types.

Teflon® Hose

The Teflon® hose is made up of a tetrafluoroethylene resin, which is processed and

extruded into tube shape to a desired size. It is covered with stainless steel wire, which is braided over the tube for strength and protection. The advantages of this hose are its operating temperature range, its chemical inertness to all fluids normally used in hydraulic and engine lubrication systems, and its long life. At this time, only medium-pressure and high-pressure types are available. These are complete assemblies with factory-installed end fittings. The fittings may be either the detachable type or the swaged type. When failures occur, replacement must be made on a complete assembly basis.

Teflon® hose is identified by metal bands or pliable plastic bands at the ends and at 3-foot intervals. These bands contain the hose military specification number, size indicated by a dash (—) and a number, operating pressure, and the manufacturer's federal supply code number. Refer to figure 10-2.

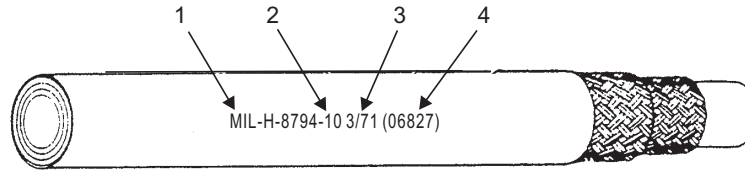

SYNTHETIC RUBBER HOSE

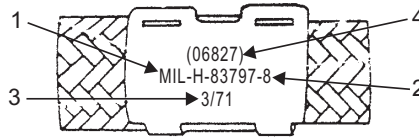

WIRE BRAID COVERED SYNTHETIC RUBBER HOSE

1. MILITARY SPECIFICATION OF HOSE
2. SIZE INDICATED BY A DASH (-) NO. OR FRACTION OF AN INCH FOR MIL-H-6000 AND MIL-H-7938 HOSES
3. CURE DATE FOR AGE CONTROL
4. MANUFACTURER'S FEDERAL SUPPLY CODE NO.

MANUFACTURER	AEROQUIP
MANUFACTURER'S CODE	0064
PART NO. WITH DASH (SIZE) NO.	AE206-10
LOT NO.	305496
OPERATING PRESSURE	3000 PSI
MILITARY SPECIFICATION	MIL-H-83298

WIRE BRAID COVERED TEFLON® HOSE LABEL

AMf10002

Figure 10-2.—Synthetic rubber hose identification.

HOSE IDENTIFICATION

Bulk hose identification will vary with the materials from which the hose is constructed. It is important that you are able to clearly identify the proper hose to be used by recognizing the various hose markings.

Synthetic Rubber

Synthetic rubber hose (if rubber-covered) is identified by the indicator stripe and markings that are stenciled along the length of the hose. The indicator stripe (also called the lay line because of its use in determining the straightness or lie of a hose) is a series of dots or dashes. The markings (letters and numerals) contain the military specification, the hose size, the cure date, and the manufacturer's federal supply code number. This information is repeated at intervals of 9 inches. Refer to figure 10-2.

Size is indicated by a dash followed by a number (referred to as a dash number). The dash number does not denote the inside or outside diameter of the hose. It refers to the equivalent outside diameter of rigid tube size in sixteenths (1/16) of an inch. A dash 8 (-8) mates to a number 8 rigid tube, which has an outside diameter of one-half inch (8/16). The inside of the hose will not be one-half inch, but slightly smaller to allow for tube thickness.

The cure date is provided for age control. It is indicated by the quarter of the year and year. The year is divided into four quarters.

1st quarter — January, February, March

2d quarter — April, May, June

3d quarter — July, August, September

4th quarter — October, November, December

The cure date is also marked on bulk hose containers in accordance with Military Standard 129 (MIL-STD-129).

Synthetic rubber hose (if wire-braid covered) is identified by bands wrapped around the hose at the ends and at intervals along the length of the hose. Each band is marked with the same information (fig. 10-2).

Teflon® Hose

Teflon® hose is identified by metal bands or pliable plastic bands at the ends and at 3-foot intervals. These

bands contain the hose military specification number, size indicated by a dash (-) and a number, operating pressure, and the manufacturer's federal supply code number. Refer to figure 10-2.

HOSE ASSEMBLY HARDWARE

Hose fittings are designed and constructed in accordance with military specifications and military standard drawings for particular hose configurations and operating pressures.

Fittings designated by a military standard drawing number have a particular dash number to indicate size. The fitting dash number does not designate a size in the same manner as a hose dash number. The fitting dash number corresponds to the dash number of the hose so that both will match at the critical dimensions to form a hose assembly.

Materials used in the construction of fittings vary according to the application. Materials include aluminum, carbon steel, and corrosion-resistant steel. Fittings that qualify under one military document may be produced by several manufacturers. Two methods or styles are used to secure the hose fitting on to the hose. They are the reusable and swage or crimp style.

Reusable Style







The preferred reusable style has modified internal threads in the socket to grip the hose properly. The fitting can be disassembled from a hose assembly and reused on another hose, provided it passes an inspection for defects. Reusable style fittings are authorized replacement fittings for replacement hose assemblies.

Swage or Crimp Style

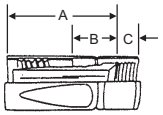
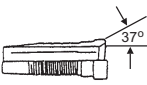
Some hose assembly manufacturers use a swage or crimp style. This style requires the socket to be permanently deformed by an electric- or hydraulic-powered machine. The deformed socket and related hardware are to be scrapped.

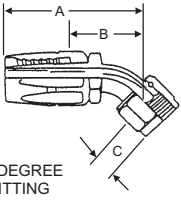
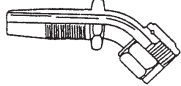
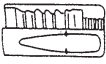

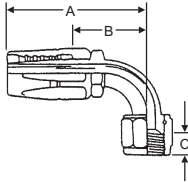
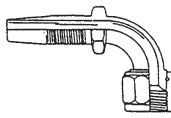
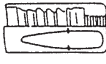



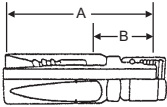

HOSE FITTINGS

Hose fittings are assemblies of separate parts. These parts are the nipple, the socket, the swivel nut or flange, and the sleeve. The nipple is the part that fits the inside diameter of the hose. Nipples have three configurations for the hose-to-tube or component surface-sealing portion. They are the flared, flareless,

FLARED			
HOSE FITTING	NIPPLE	SOCKET	NUT
 <p>STRAIGHT FITTING</p>			
 <p>45 DEGREE FITTING</p>			
 <p>90 DEGREE FITTING</p>			

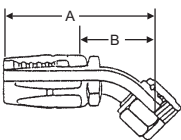
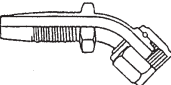
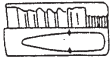
AMF10003A

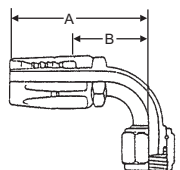
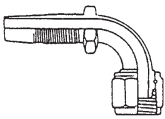
Figure 10-3.—Synthetic hose fittings.

FLARELESS			
HOSE FITTING	NIPPLE	SOCKET	NUT
 <p>STRAIGHT FITTING</p>			
 <p>45 DEGREE FITTING</p>			
 <p>90 DEGREE FITTING</p>			

AMF10003B

Figure 10-3.—Synthetic hose fittings—(Continued).

and flanged configurations, as shown in figure 10-3. The socket fits over the outside diameter of the hose and secures one end of the nipple to the hose. The swivel nut or flange secures the other end of the nipple to the mating connection in the fluid system. For Teflon® hose, some manufacturers have a sleeve in addition to the nipple, socket, and nut or flange. See figure 10-4 for illustrations of Teflon® hose fittings and sleeves. Individual parts produced by each manufacturer may

have unique characteristics and tolerances that prevent interchangeability between parts. Do not intermix nipples and sockets from one manufacturer to another.

Hose fittings are identified by applicable military specification (MS) and manufacturer's name or trademark on fittings and nuts. Flared or flareless fittings and nuts are color-coded to show materials or material finishes. See table 10-1.

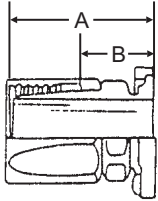
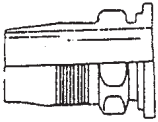
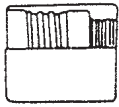
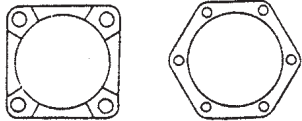
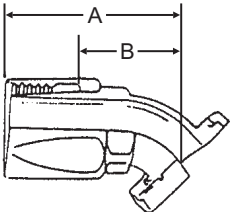
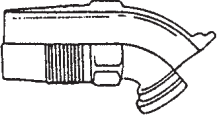
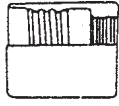
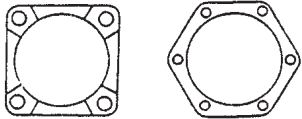
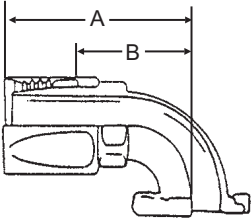
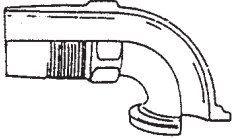
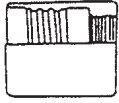
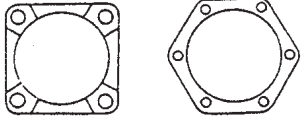
FLANGED			
HOSE FITTING	NIPPLE	SOCKET	FLANGE
 <p>STRAIGHT FITTING</p>			
 <p>45 DEGREE FITTING</p>			
 <p>90 DEGREE FITTING</p>			

AMF10003C

Figure 10-3.—Synthetic hose fittings—(Continued).

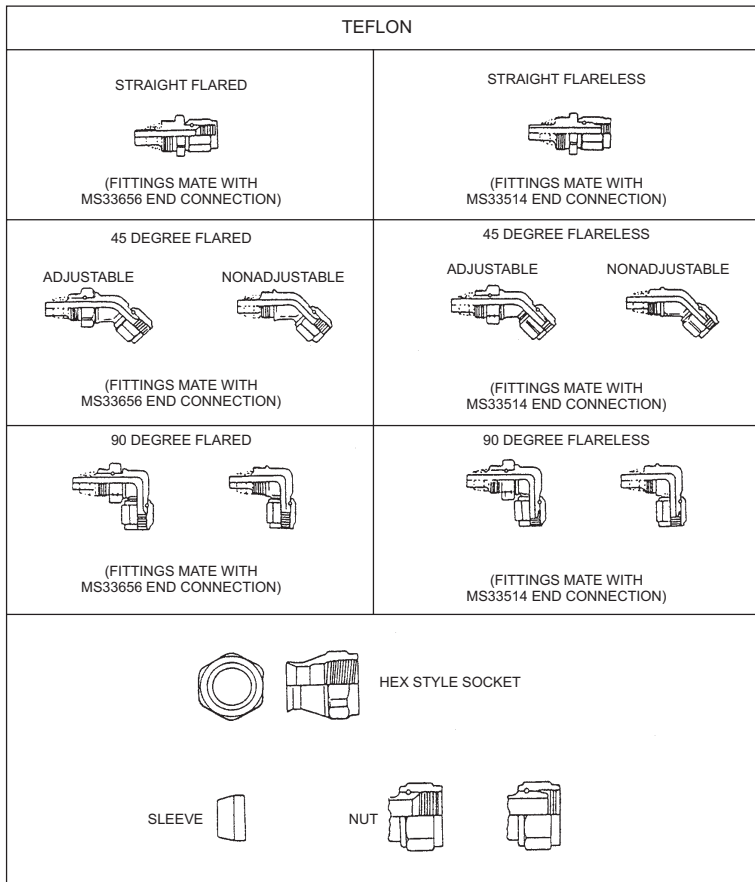

AM110004A

Figure 10-4.—Teflon® hose fittings.

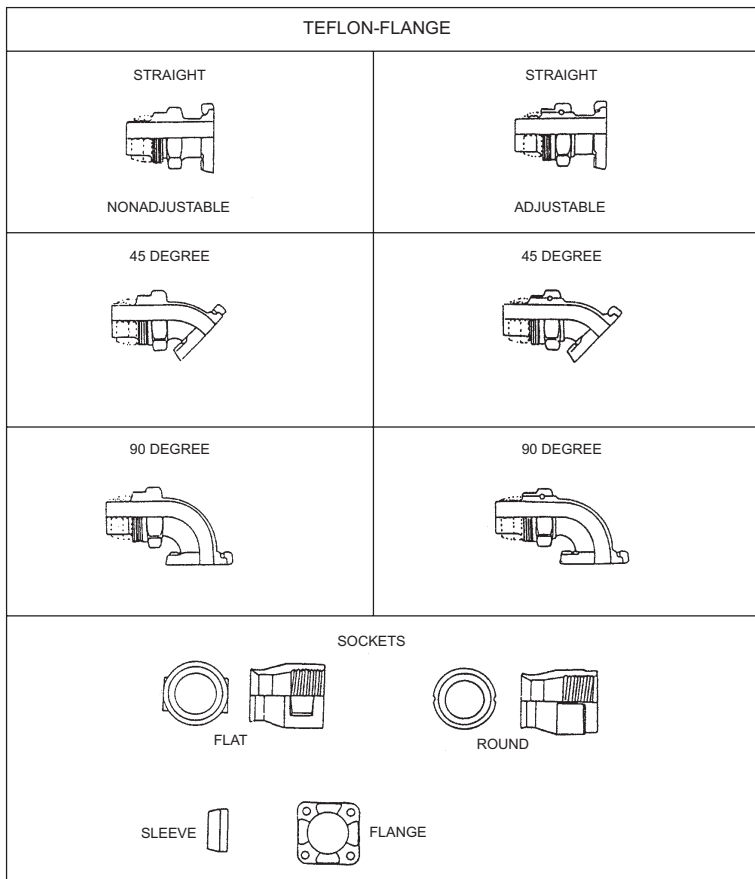

AM110004B

Figure 10-4.—Teflon® hose fittings—(Continued).

Table 10-1.—Hose Fitting Color and Material Code

Flared Fittings MIL-F-5509	Color	Material Code
Aluminum Alloy 2014 and 2024(1)	Blue	D (Optional)
Aluminum 7075(1)	Brown	W(T-73)
Steel	Black	
Copper Based Alloys	Natural Cadmium Plate if Applicable	
Corrosion Resistant Steel	None	
Class 304		J
Class 316		K
Class 347		S
Titanium Alloys	Gray	T
Flareless Fittings MIL-F-18280	Color	Material Code
Aluminum Alloy 2014 and 2024	Green	D
Aluminum Alloy 7075	Brown	W (T-73)
Carbon Steel	Yellow (result of Chromate treatment)	
4130 Steel Forging		F
Stainless Steel	Natural Finish	
Class 304		J
Class 316		K
Class 347		S
Titanium Alloy	Gray	T
NOTE		
(1) Duplex steel may distort color of aluminum anodize.		

IDENTIFICATION OF HOSE ASSEMBLIES

All hose assemblies are identified by tags, bands, or tapes. Some identifications are permanently marked while others are removable. Removable tags, bands, or tapes should not be installed on hose assemblies located inside fuel and oil tanks or in areas of an aircraft where tags, bands, or tapes could be drawn into the engine intake. Hose assemblies are either commercially manufactured or locally fabricated.

Commercially Manufactured

Commercially manufactured hose assemblies are made from synthetic rubber or Teflon®. The assemblies are identified by a band near one end of the

assembly. This band identifies the assembly manufacturer's code or trademark and military specification (MS) part number, including dash size, operating pressure (in pounds per square inch, psi), date of assembly (in quarter and year), hose manufacturer's code number (if different from assembly manufacturer), and the cure date of the hose manufacturer (in quarter and year).

The assembly date is indicated by the letter **A**, followed by the quarter of the year, the letter **Q**, and ends with the last two digits of the year. For example, hose assemblies fabricated during June 1980 are marked A2Q80. When a decal or band is used that states "assembly date," the **A** may be omitted. Assembly date information is also indicated on the unit,

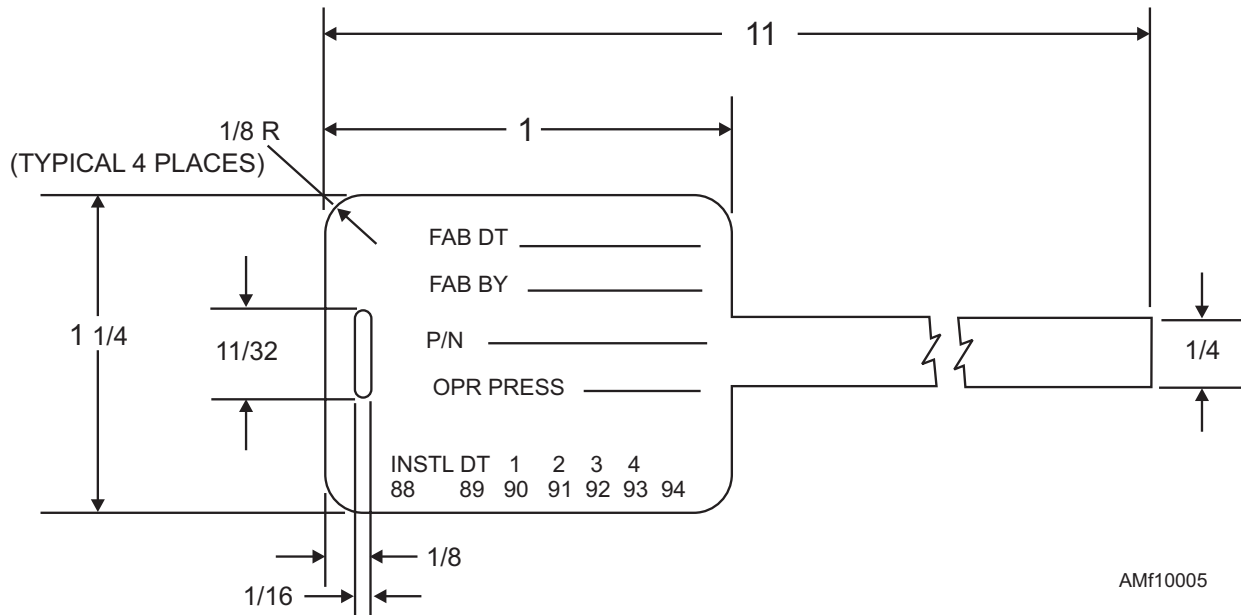

Figure 10-5.—Hose assembly identification tags.

intermediate, and shipping containers containing a single item. Exterior shipping containers that contain major assemblies made up of two or more assemblies with rubber items are identified by the oldest assembly in the container.

Commercially manufactured Teflon® hose assemblies are identified by a permanently marked and attached band on the assembly. The band contains the assembly manufacturer's name or trademark; hose manufacturer's federal supply code number; hose assembly part number; operating pressure-in psi, pressure test symbol (PT), and the date of hose assembly manufacture (in month and year).

Locally Fabricated

Hose assemblies manufactured by depot and intermediate maintenance activities are identified with hose assembly identification tags or labels. The hose assembly identification tag is a metal tag that contains the basic hose assembly and part number, date of fabrication (in quarter and year), operating pressure (in psi), and organizational code of the activity fabricating the hose assembly. Figure 10-5 shows where this information is located. All marking of the tag is to be done prior to its attachment to the hose assembly. Install the hose assembly identification tag by wrapping the band snugly around the hose, inserting the tab through the slot and pulling it tight; crimp the tab after bending the tab back; and finally, cut away the excess tab after crimping. A length of not less than one-half inch must

remain between the tag and the end fitting after proof pressure testing has been performed.

Use labels (fig. 10-6) to identify hose assemblies located in areas where a tag may be drawn into an engine intake or where hose assemblies are covered with heat-shrinkable tubing. Place the label 1 inch from the socket and apply a 2 1/2-inch piece of clear, heat-shrinkable tubing, MIL-R-46846, type V, over the label and hose. Function and hazard labels can be applied in the same manner.

HOSE FABRICATION

Fabricating hose assemblies from bulk hose and reusable end fittings requires some basic skills and a few hand tools. The skills required are the ability to follow step-by-step instructions and to use the required hand tools.

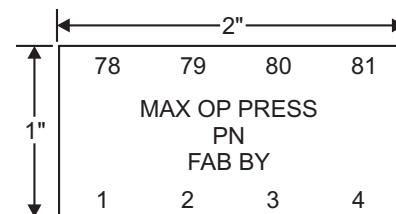

(MATERIAL: WHITE POLYESTER FILM PER MIL-P-38477.)

AMf10006

Figure 10-6.—Hose assembly labels.

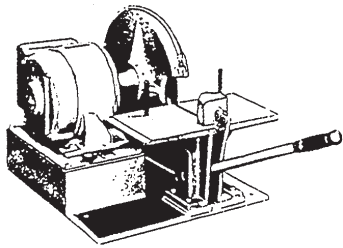

HOSE CUT OFF MACHINE

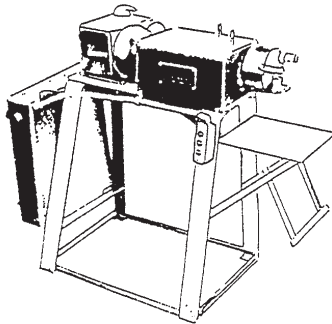

SOCKET ASSEMBLY MACHINE

AMF10007

Figure 10-7.—Hose fabricating machines.

Equipment and Tools

Fabricating hose assemblies is a function of intermediate- and depot-level maintenance. The intermediate and depot shops are equipped with hose fabricating machines (fig. 10-7) and proof-test equipment. Each machine or equipment is supplied with operating instructions.

The basic hand tools that are required to fabricate hose assemblies up to 3,000 psi operating pressure are a bench vise, a hose cutoff machine, open end wrench sets, a sharp knife, slip joint pliers, an oil can for lubricating oil, a marking pencil, a small paint brush, masking or plastic electrical tape, a steel ruler, a thickness gauge (leaf type), and a protractor.

Mandrels are special hand tools (fig. 10-8) that are **not** required but are recommended for fabricating hose assemblies. During hose assembly fabrication, mandrels can be used to protect sealing surfaces, support inner tubes, and guide fitting nipples into hoses.

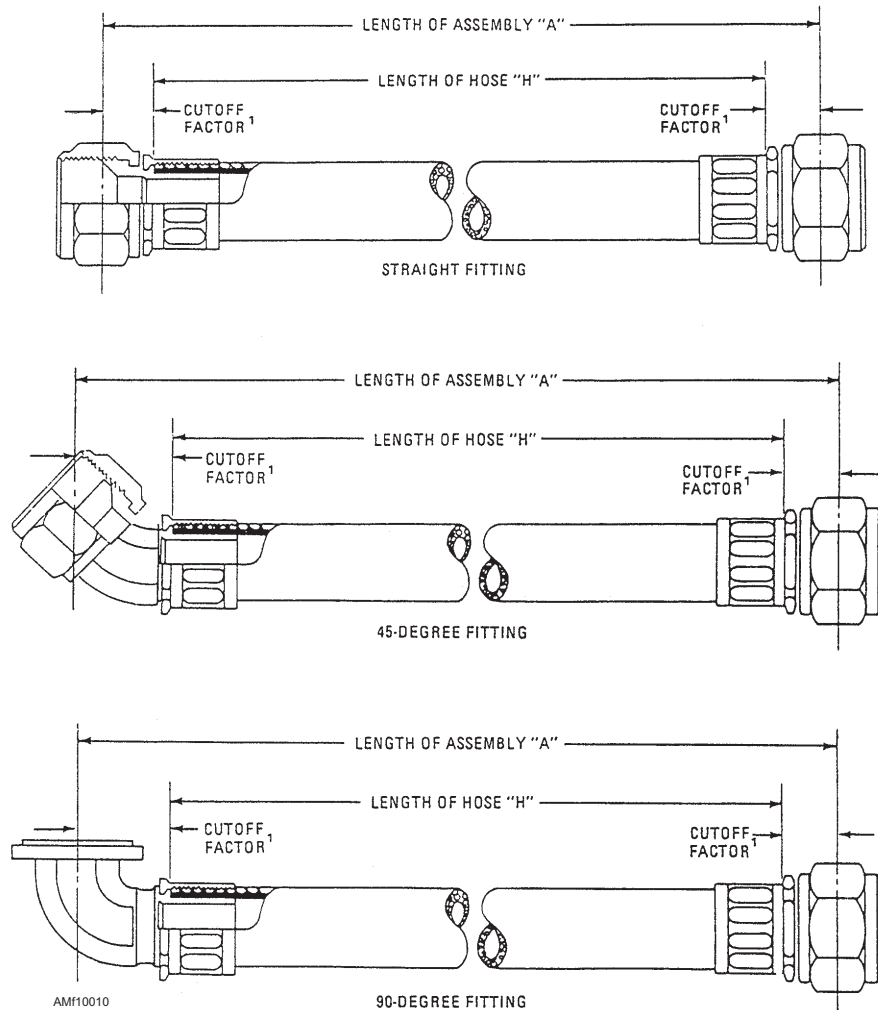
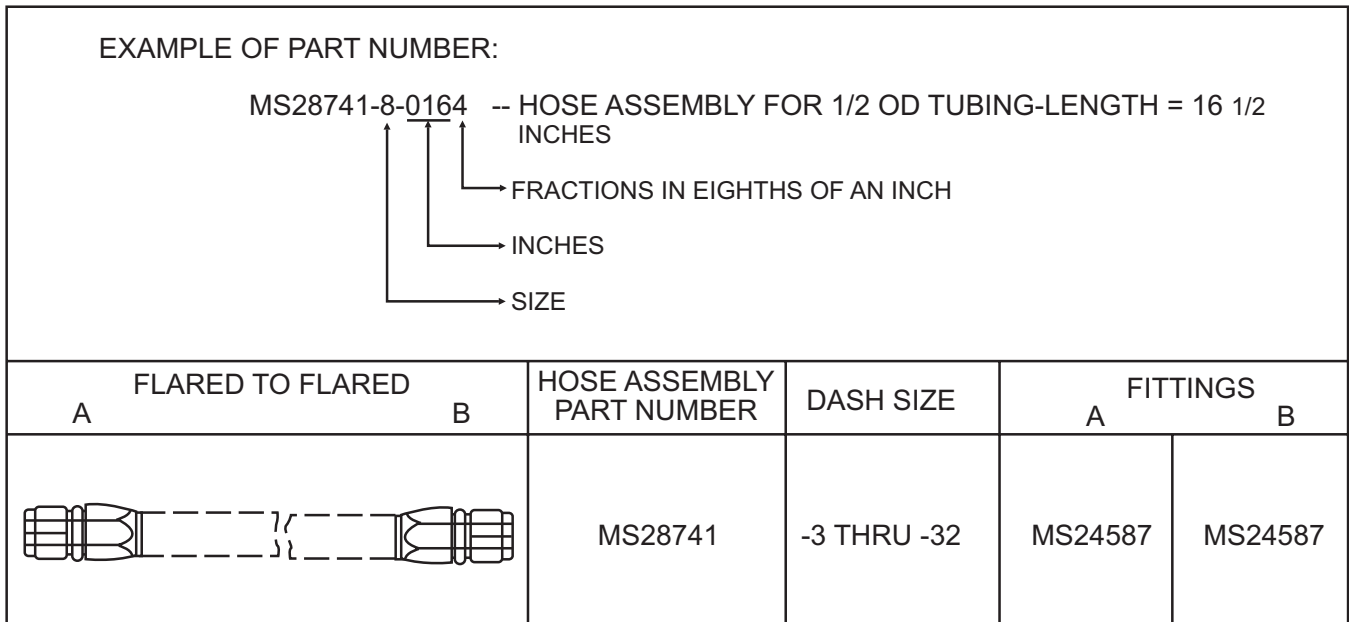

Figure 10-8.—Mandrel kits.



AMf10009

Figure 10-9.—Synthetic rubber medium-pressure hose assembly.

Procedures

When failure occurs in a flexible hose equipped with swaged end fittings, the unit is generally replaced without attempting a repair. The correct length of hose, complete with factory-installed end fittings, is drawn from supply.

When failures occur in hose assemblies equipped with reusable style end fittings, the fabrication of the replacement unit is the function of the intermediate and

depot organization levels. Undamaged end fittings on the old length of hose may be removed and reused; otherwise, new fittings must be drawn from supply along with a sufficient length of hose.

The following assembly procedures are for instructional purposes only. When fabricating hose assemblies, refer to the *Aviation Hose and Tube Manual*, NAVAIR 01-1A-20. Hose assembly part number MS 28741-80164 (fig. 10-9), per MIL-H-8795, is used here as an example of fabrication procedures.

Table 10-2.—Hose Cutoff Factor (In Inches)

	FITTING	HOSE SIZE (DASH NUMBER AND/OR LETTER)										
	P/N	-3	-4	-5	-6	-8	-10	-12	-16	-20	-24	-32
STRAIGHT FLARED 	MS27616		.92		1.02	1.16						
	MS27053	.70	.74	.77	.81	.93	1.05	1.13	1.30	1.44	1.66	
	MS28760		.79		.99	1.10	1.19	1.35	1.59			
	MS18085	.42	.41	.42	.47	.58	.63	.61	.67	.79	.86	
	MS24587	.60	.60	.70	.77	.94	1.00	1.00	.94	.99	1.09	1.24
	MS27404		.46		.55	.68	.73					
	MS87018	.64	.65	.70	.76	.94	.99	1.00	1.16	1.34	1.44	1.62
	OR M83798/1	.74*	.74*	.76*	.84*	.97*	1.05*	1.11*	1.34*	1.54*	1.70*	

NOTES:

* Hose fittings manufactured by Stratoflex (98441) have different cut-off factors.

AMf10002

The first step is to determine the necessary hose length from table 10-2 and figure 10-10. Wrap the circumference of the hose with masking or plastic electrical tape at the cutoff to prevent flare-out of braid if the hose outer cover is wire braid. Hose with rubber or fabric outer cover does not require wrapping with tape. Measure the hose to the required length and cutoff the square, using the cutoff machine (fig. 10-7). Blow the hose clean with filtered shop air after cutting. Remove the tape and the clamp socket in a vise (fig. 10-11). Do not overtighten vise on thin-walled lightweight fittings. Screw the hose counterclockwise into the socket using a twisting, pushing motion until the hose bottoms on the socket shoulder. Back the hose out 1/4 turn. Assemble the nipple and nut with a standard adapter of the same size and thread (fig. 10-12). Lubricate the inside bore of the hose and the outside surface of the nipple with hydraulic fluid, MIL-H-5606, MIL-H-83282, or MIL-H-6083 (fig. 10-13). Clamp the socket with the hose into a vise. Insert the nipple assembly into the hose and socket by using a wrench on the hex of the insertion tool. Turn the nipple assembly clockwise until the nut-to-socket gap is between 0.005 and 0.031 inch. The gap allows the nut to turn freely about its axis (fig. 10-14). Remove the insertion tool from the assembly. Repeat the procedure for hose assemblies with straight fittings on both ends.

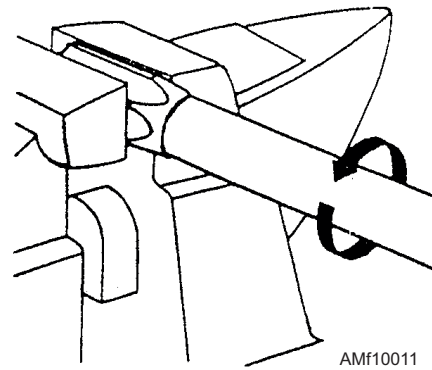

Figure 10-11.—Hose insertion.

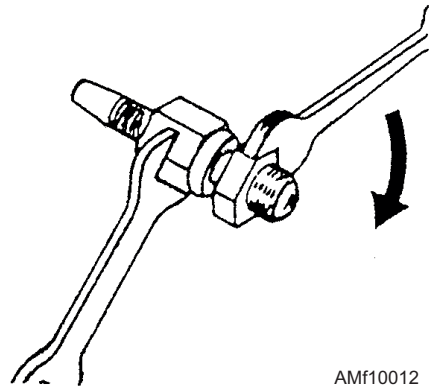

Figure 10-12.—Nipple and nut assembly.

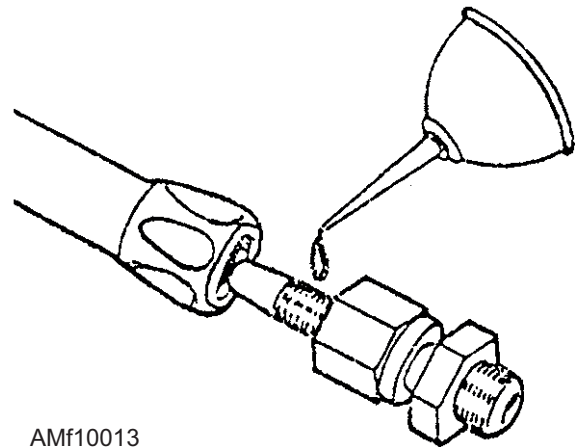

Figure 10-13.—Assembly lubrication.

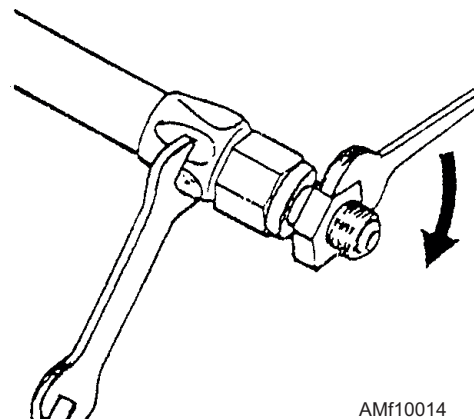

Figure 10-14.—Nipple assembly adjustment.

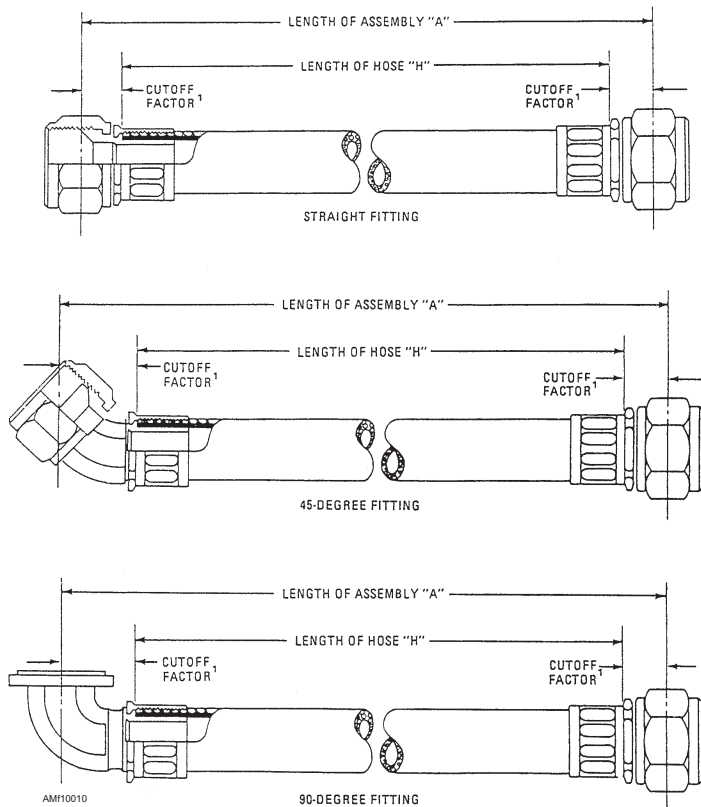

Figure 10-10.—Determining hose assembly length.

PREFORMED HOSE ASSEMBLIES.—

Medium-pressure Teflon® hose assemblies are sometimes preformed to clear obstructions and to make connections using the shortest possible hose length. Since preforming permits tighter bends that eliminate the need for special elbows, preformed hose assemblies save space and weight. Preformed hose assemblies must be procured from a qualified commercial source (source code P series). When preformed hose assemblies are unavailable and could cause a work stoppage, fabrication by depot and intermediate maintenance is authorized.

PROTECTIVE COVERS.—Some hose assemblies are located in areas where temperatures exceed the capabilities of the hose material. Protective firesleeves (covers) should be installed (fig. 10-15) over these hose assemblies. Firesleeves do not increase the service temperature of hoses, but protect the hose from direct fire long enough to allow the appropriate action to be taken. The sleeve is composed of fiber glass. It is impregnated and overlaid with a flame-resistant silicone rubber.

Cleaning

Fabricated hose assemblies should be cleaned and visually inspected for foreign material before and after proof testing. Cleaning should be done with cleaning fluid or a detergent solution.

In cleaning hose or hose assemblies, the cleaning procedures used depend upon the cleaning material selected for cleaning. The preferred cleaning method is one that also uses the preferred cleaning material, MIL-PRF-680, type II.

CAUTION

Oxygen hose assemblies must be cleaned and tested by qualified aviation equipment personnel in accordance with NAVAIR 13-1-6-4 before installation in weapons systems. Degreasing Solvent MIL-PRF-680 is combustible and should be kept away from open flames. It should be used in a well-ventilated area. Personnel should wear rubber gloves and chemical or splashproof goggles. Avoid skin contact. Consult with the local safety office regarding respiratory protection.

Immerse or flush the hose or hose assembly using MIL-PRF-680, type II, solvent or equivalent. Brush the exterior of the hose or hose assembly with a nylon

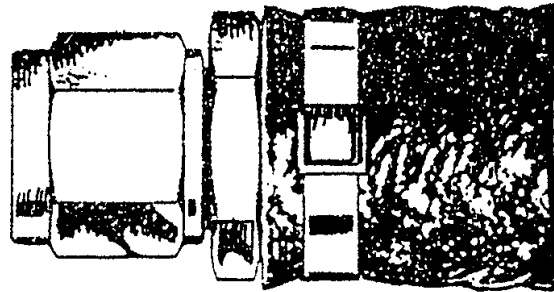

AMf10015

Figure 10-15.—Firesleeve.

or similar synthetic bristle brush that has a corrosion-resistant core. Brush the core and at least the first inch of hose with a brush that has a diameter of at least 1/16 inch larger than the fitting bore. Flush the hose or hose assembly with MIL-PRF-680, type II, or equivalent. Drain the cleaning fluid and blow-dry with dry, filtered, oil-free air or nitrogen. Install the protective closures if the hose or hose assembly is not to be cleaned further or proof tested immediately.

Proof Pressure Testing

Hose assemblies must be proof pressure tested after fabrication. Ballistic and oxygen hose assemblies must be cleaned and tested by qualified aviation equipment personnel in accordance with NAVAIR 13-1-6-4 before installation in weapons systems.

Observe all safety rules when you proof pressure test hose assemblies, and proceed as follows to proof pressure test hose assemblies. Clean hose assembly. Select test media from table 10-3. Select proof pressure. See table 10-4, which is a section of the typical hose assembly proof pressure test data sheet. Test one hose assembly at a time. Several hose assemblies that require the same proof pressures may be tested together, if they are connected in series with adapters.

Unless otherwise directed, a manifold hose assembly that contains different sizes or types of hose will be tested at the lowest proof pressure required by any one size or type contained in the manifold. Arrange hose assemblies as close to the horizontal position as possible. Allow trapped air to escape when testing hose assemblies in a liquid test medium. When testing an air or gas medium, test hose assemblies underwater so that trapped air can escape from the hose's braided outer covers. Hose assemblies with a firesleeve do not require the underwater test. Tighten the pressure cap. Apply proof pressure for a minimum of 30 seconds, but no longer than 5 minutes. Check leakage while maintaining proof pressure.

Table 10-3.—Proof Pressure Test Media

Hose Type	Test Media ¹
Hydraulic	Water, MIL-H-6083 or MIL-H-46170, type II.
Pneumatic or Gaseous	Water, MIL-H-6083, nitrogen (clean, dry and oil-free), air (clean, dry and oil-free) or MIL-H-46170, type II.
Oil	Water or nitrogen (clean, dry and oil-free).
Coolant	Water.
Fuel (nonself-sealing)	Water, MIL-H-6083 or MIL-H-46170, type II.
Fuel (self-sealing)	Water, air (clean, dry and oil-free) or nitrogen (clean, dry and oil-free).
Air	Water or air (clean, dry and oil-free).
Instrument	Water or nitrogen, grade A, type 1 (BB-N-411).
¹ Use Flow Cool or Coolanol for systems using Flow Cool or Coolanol.	

Table 10-4.—Hose Assembly Proof Pressure Test Data

Hose Type & MIL-SPEC No.	Test Condition	Hose Size (Dash Number)							
		2	3	4	5	6	8	10	
Rubber Low Pressure AN6270	Operating Pressure	300	250	200	—	150	150	150	
	Proof Pressure	600	500	500	—	300	250	250	
	Burst Pressure	2000	1700	1700	—	1000	750	700	
Rubber Medium Pressure MIL-H-8795	HYDRAULIC	Operating Pressure	—	2000	3000	3000	2000	2000	1750
		Proof Pressure	—	4000	6000	5000	4500	4000	3500
		Burst Pressure	—	8000	12000	10000	9000	8000	7000
	FUEL	Operating Pressure	—	1000	1000	1000	1000	1000	1000
		Proof Pressure	—	1500	1500	1500	1500	1500	1500
		Burst Pressure	—	8000	12000	10000	9000	8000	7000
	OIL	Operating Pressure	—	50	50	50	50	50	50
		Proof Pressure	—	600	600	600	600	600	600
		Burst Pressure	—	8000	12000	10000	9000	8000	7000
NOTES:									
Typical operating pressures and burst pressure are included for information purposes only.									
Operating pressures are minimum (psi min), and proof pressures and burst pressures are maximum (psi max).									

After the completion of the proof pressure test, drain the hose assembly and clean. Install the protective closures. Install the identification tag. Prepare the hose assembly for installation or storage.

TEST STANDS

All flexible hose manufactured in the shop must be hydraulic or pneumatic pressure tested prior to installation in the aircraft. Two types of hose burst test stands, Greer and CGS Scientific, are typical of those used for this purpose.

Aircraft Hydraulic Hose Test Stand (Greer)

The hose test stand shown in figure 10-16 is manufactured by Greer Hydraulics, Incorporated. This test stand is designed especially for proof pressure testing aircraft hose assemblies and is capable of developing static pressures up to 30,000 psi.

The high static pressures required for proof testing are produced by a booster pump powered by shop air having a pressure of 80 to 120 psi. The unit is mounted on four legs, which provide mounting holes for bolting it to the deck. Figure 10-17 shows the instruments and controls, and table 10-5 lists the functions of each. You should be familiar with these instruments and controls before using the test stand. To operate the aircraft hydraulic hose test stand (Greer), follow the procedures described below.

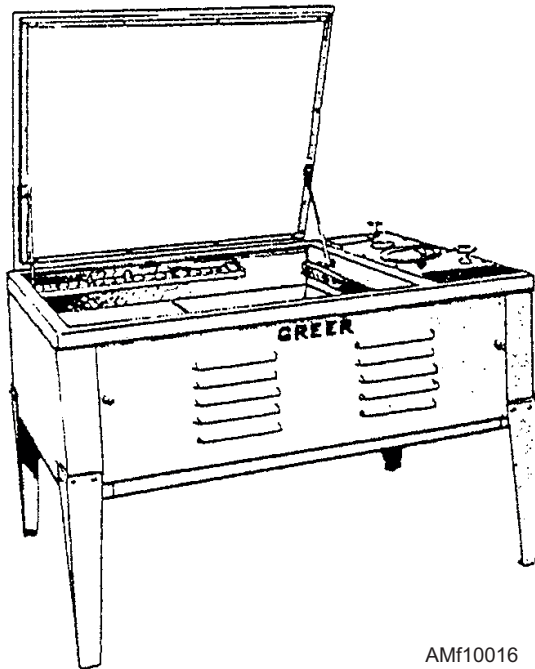

AMf10016

Figure 10-16.—Aircraft hose burst test stand (Greer).

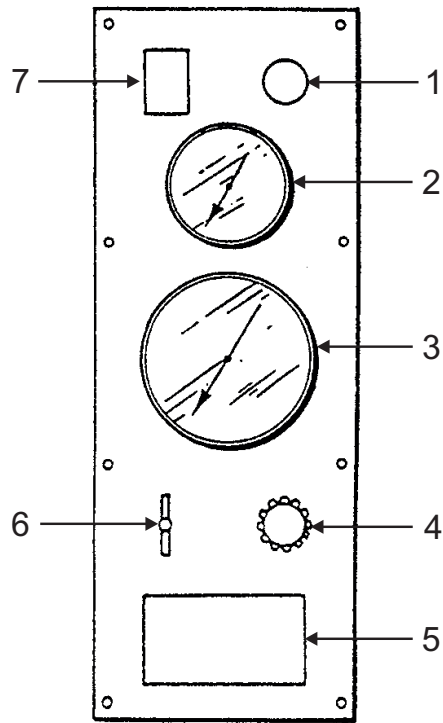

1. SHOP AIR SHUTOFF VALVE
2. REGULATED AIR PRESSURE GAUGE
3. FLUID PRESSURE GAUGE
4. AIR PRESSURE REGULATOR
5. SCHEMATIC FLOW DIAGRAM
6. FLUID OUTLET VALVE
7. NAMEPLATE

AMf10017

Figure 10-17.—Instruments and controls.

Before you operate the test stand, make the following checks and adjustments: Make sure that the reservoir is filled. Connect the shop air supply line to the stand and open the air shutoff valve. Turn the pressure regulator to the low-pressure position. There are no special starting instructions since the stand starts to operate as soon as air pressure is admitted into the circuit by opening the air shutoff valve. The stand may be warmed up by capping all pressure outlet ports, opening the fluid outlet valve, and allowing the pump to operate for 1 minute.

INSTALLING HOSE LINES FOR TEST.—

With the air pressure regulator set at zero, lift the cover to the open position. Select the proper size adapter (with O-ring) to fit the hose line to be tested, and install it in the pressure manifold outlet port. Connect one end of the test hose line to the manifold adapter. Plug the manifold ports not being used. Connect the bleed valve to the adapter. Connect a second adapter on the other

Table 10-5.—Function of Controls and Instruments

Index No.	Nomenclature	Functions
1	Air inlet shutoff valve	Connects the shop air to the test stand.
2	Air pressure gauge	This is a 0-160 psi pressure gauge. It registers the regulated air pressure being supplied to the booster pump.
3	Fluid pressure gauge	This is a 0-30,000 psi gauge. It is used to indicate the fluid pressure under which the hose lines are tested. This gauge is provided with a red following pointer and manual reset (for indicating maximum pressure applied to test hose).
4	Pressure regulator	This is a relieving type air pressure regulator. It is used to set the air pressure to the booster pump to give the desired fluid pressure in the pressure manifold. Fluid pressure may be regulated by varying the adjustment on this regulator.
5	Schematic diagram	Mounted on instrument panel.
6	Outlet valve	This is a manual shutoff valve which is used to bleed air from manifold and to relieve fluid pressure upon completion of test.
	Bleed valve (located inside of test chamber).	There are six of these valves. They are used for bleeding air from hoses under test.
	Pressure relief valve (located under panel).	This is a diaphragm type air pressure relief valve. It is adjustable by means of an adjusting screw. This valve limits the air pressure to the desired maximum for safe operating condition. An audible whistling noise is indicated as a warning signal, preventing overpressure and possible damage to the stand components.

end of the test hose. Close the Plexiglas cover before starting the test.

GREER TEST PROCEDURES.—Hose lines should be tested in accordance with the applicable military specification; for example, MIL-H-5593 or MIL-H-8794. Each hose specification gives proof test pressures and other pertinent data for that particular type hose. Static pressure is developed by closing the outlet valve and increasing pressure with the pressure regulator. The pressure in the test hose is indicated on the fluid pressure gauge. The red follower pointer will indicate the maximum pressure applied to the hose. This pressure may be increased or decreased by adjusting the pressure regulator.

After the test is complete, the stand is stopped by slowly opening the outlet valve and decreasing the pressure with the pressure regulator. When the fluid pressure gauge reads zero, the Plexiglas cover may be raised, and the test hose is disconnected and removed.

Hose Burst Test Stand (CGS Scientific)

The hose burst test stand, shown in figure 10-18, is manufactured by CGS Scientific Corporation. This test stand provides a means for pressure testing of aircraft

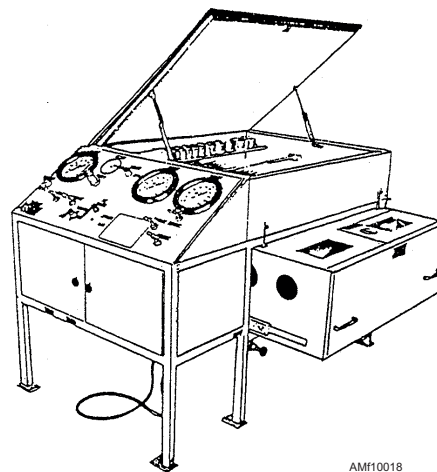

Figure 10-18.—Aircraft hose burst test stand (CGS Scientific).

hose assemblies of various lengths and sizes. Hydraulic pressure up to 15,000 psi and pneumatic pressure up to 1,500 psi are available for the testing of the hoses. The test stand is a completely self-contained unit mounted on legs that permits bolting to the deck. Access doors and removable panels provide easy access to all components for maintenance. Figure 10-19 shows the controls and instruments, and table 10-6 lists the functions of each. You should be familiar with these controls and instruments before using the test stand. To operate the hose burst test stand (CGS Scientific), follow the procedures listed below.

Before you perform the following preliminary adjustments, ensure that the air and electrical systems are energized. Check the reservoir oil level. If the reservoir is not full, add hydraulic oil. Make sure that the manifold bypass valve is closed. Open the manifold bleed valve. Make sure that the air booster inlet valve is closed. Make sure that the high-pressure air bleed valve is closed. Set the air pressure regulator for minimum pressure (fully counterclockwise). Turn on the gauge shutoff valve. Set red follower needles on the gauges to zero.

INSTALLING HOSE LINES FOR TEST.—For the hydraulic testing of hoses, take the following actions. Open the Plexiglas door on the hydraulic test chamber. Remove the plugs from the manifold ports. Select the proper size adapters for the hose lines being tested, and install them in the manifold ports. Connect the hose lines to be tested between the two manifolds. Close the hinged door at the top of the test chamber.

NOTE: The distance between the manifolds is adjustable for various hose lengths. Loosen the thumbscrews that secure the rear manifold and slide it backward or forward on the tracks to obtain the desired distance.

For the pneumatic testing of hoses, take the following actions. Unlock the two side bolts that secure the pneumatic chamber in the retracted position. Pull out the chamber to the extended position and secure it with the two slide bolts. Unlatch and open the two doors at the top of the pneumatic chamber. Open the hinged screens inside the chamber. Select a suitable adapter and connect the hose to be tested to the connection in the chamber. Use a suitable plug to seal the opposite end of the test hose. Close the hinged screens. Close and lock the two doors at the top of the chamber.

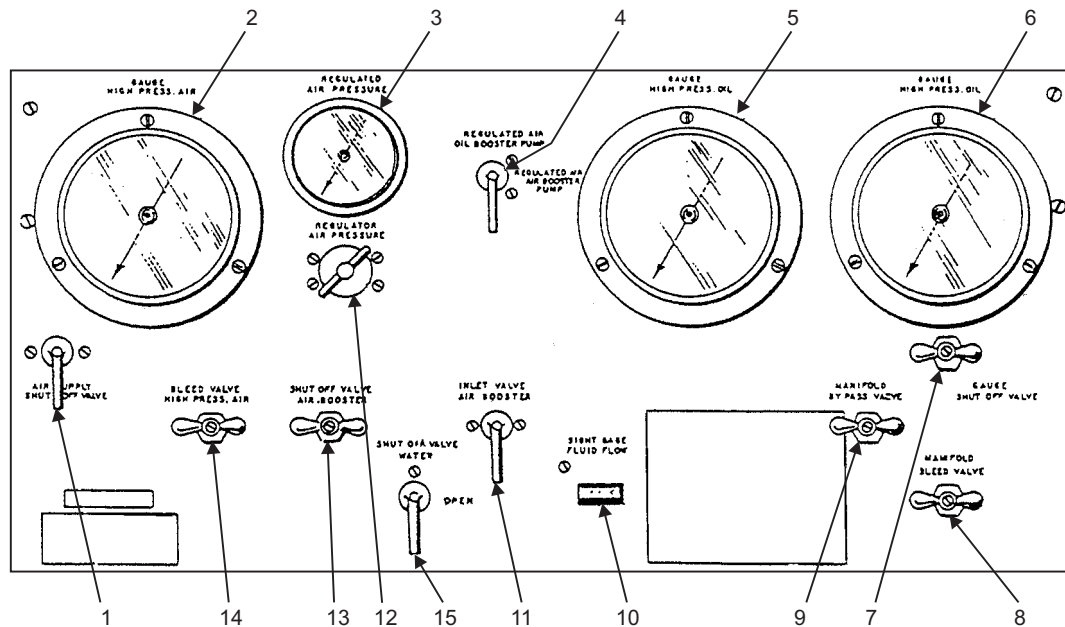

- | | | |
|------------------------------|------------------------------|-----------------------------|
| 1. AIR SUPPLY SHUTOFF VALVE. | 5. HIGH-PRESSURE OIL GAUGE | 12. AIR PRESSURE REGULATOR. |
| 2. HIGH-PRESSURE AIR GAUGE | (0-20,000 psi). | 13. AIR BOOSTER SHUTOFF |
| (0-2,000 psi). | 6. HIGH PRESSURE OIL GAUGE | VALVE. |
| 3. REGULATED AIR PRESSURE | (0-2,000 psi). | 14. HIGH-PRESSURE AIR BLEED |
| GAUGE (0-160 psi). | 7. GAUGE SHUTOFF VALVE. | VALVE. |
| 4. SELECTOR VALVE, | 8. MANIFOLD BLEED VALVE. | 15. WATER SHUTOFF VALVE. |
| REGULATED AIR TO OIL | 9. MANIFOLD BYPASS VALVE. | |
| BOOSTER PUMP OR AIR | 10. SIGHT GAUGE. | |
| BOOSTER PUMP. | 11. AIR BOOSTER INLET VALVE. | |

Figure 10-19.—Controls and instruments.

AMF10019

Table 10-6.—Functions of Controls and Instruments

Index No.	Nomenclature	Function
1	Air supply shutoff valve.	Used for turning on and shutting off the shop air supply to the test stand.
2	High-pressure air gauge (0-2,000 psi).	Indicates the air pressure being applied to the hose undergoing pneumatic test. A red follower pointer indicates the maximum pressure applied to the hose. A manual reset knob is provided for resetting the follower pointer to zero.
3	Regulated air pressure gauge (0-160 psi).	Indicates the regulated air pressure being supplied to the oil boost pump or the air boost pump.
4	Selector valve.	Selects regulated air supply for the oil boost pump (hydraulic testing) or the air boost pump (pneumatic testing).
5, 6	High-pressure oil gauge (0-2,000 and 0-20,000 psi).	Indicates the hydraulic pressure being applied to the hoses undergoing hydraulic test. A red follower pointer on each gauge indicates the maximum pressure applied to the hoses. A manual reset knob is provided on each gauge for resetting the follower pointer to zero.
7	Gauge shutoff valve.	Provides a means for shutting off pressure to the 0-2,000 psi oil pressure gauge when using test pressures in excess of 2,000 psi.
8	Manifold bleed valve.	Used for bleeding air from the test hoses and manifolds before applying full hydraulic test pressures. Also used to release hydraulic pressure in the test hoses and manifolds after test.
9	Manifold bypass valve.	Bypasses the manifolds when turned on. Used to relieve pressure on the manifolds at the completion of test.
10	Fluid flow sight gauges.	Provides a means for detecting air bubbles in the hydraulic oil passing from the bleed valve to the oil reservoir.
11	Air booster inlet valve.	Used to turn on and shut off the unregulated air supply to the air boost pump.
12	Air pressure regulator.	Used for setting the input air pressure to the oil boost pump during hydraulic testing to give the desired hydraulic test pressure. Also used for setting the input air pressure to the air boost pump during pneumatic testing to give the desired pneumatic test pressure.
13	Air booster shutoff valve.	May be turned off after pressure is built up in the test hose; it holds the test pressure and permits the air booster to be shut down.
14	High-pressure air bleed valve.	Provides a means for releasing the air pressure in the test hose after test.
15	Water shutoff valve.	Used for turning on the water to fill the pneumatic test chamber.

CGS SCIENTIFIC TEST PROCEDURES.—

Hose lines should be tested in accordance with the applicable military specification. Each hose specification gives proof test pressures and other pertinent data for that particular type of hose. Perform hydraulic testing as follows: Make all the preliminary adjustments and install the test hoses as described previously. Turn the selector valve to the oil boost pump position. Turn on the air supply shutoff valve. Slowly open the air pressure regulator until air-free oil passes through the fluid flow sight gauge; then close the manifold bleed valve. Increase the pressure on the test hoses to the specified value by adjusting the air pressure regulator until the desired pressure is indicated on the high-pressure oil gauges.

CAUTION

If pressure will exceed 2,000 psi, turn off the gauge shutoff valve. This shuts off the pressure to the 0-2,000 psi high-pressure oil gauge. Continue to read the 0-20,000 psi gauge. The test hoses may be observed through the Plexiglas window in the test chamber door while under test pressure. The pressure may be increased during test by adjustment of the air pressure regulator.

To perform pneumatic testing, proceed as follows. Make all the preliminary adjustments and install the test hoses as described previously. Turn on the air booster inlet valve. Make sure that the air booster shutoff valve is turned on. Turn the selector valve to the air boost pump position. Turn on the air supply shutoff valve. Increase the pressure on the test hose by adjusting the air pressure regulator until the desired pressure is indicated on the high-pressure air gauge.

CAUTION

Keep the test hose at test pressure for 2 minutes before turning on the water shutoff valve. A ruptured test hose, with water in the pneumatic chamber, could cause injury to personnel.

Turn on the water shutoff valve and fill to the level inside the test chamber. Observe the test hose for air leaks through the shatterproof glass windows at the top of the test chamber. Air bubbles rising in the water indicate a leaking hose or fitting. When you complete the hydraulic test, stop the operation of the test stand. Adjust the air pressure regulator for a zero reading on the regulated air pressure gauge. Shut the air supply

shutoff valve. Open the manifold bypass valve. When the high-pressure oil gauge indicates a zero pressure, open the test chamber door and disconnect and remove the test hoses.

After you complete the pneumatic test, stop the operation of the test stand. Adjust the air pressure regulator for a zero reading on the regulated air pressure gauge. Shut off the air supply shutoff valve. Open the high-pressure air bleed valve. When the high-pressure air gauge indicates a zero reading, drain the water by means of the drain valve at the bottom of the chamber. Open the test chamber doors and disconnect the test hose.

MAINTENANCE

Maintenance of hose and hose assemblies at the organizational level is limited to contamination control, preventive maintenance, removal, installation, or replacement. Proper maintenance practices can minimize the problems that might occur with regard to hose and hose assemblies.

Maintenance Practices

Do not use hose or hose assemblies as foot or hand holds. Do not lay hose or hose assemblies where they may be stepped on or run over by vehicles. Do not lay objects on hose or hose assemblies. Turn the swivel nut when loosening or tightening fittings. Hold the socket only to prevent the hose assembly from turning. Perform all necessary turnoff or shutdown procedures as outlined in the applicable maintenance instruction manuals (MIMs) or technical directives before removing any hose or hose assembly. Cover open ends of hose, hose assemblies, and fittings with protective closures. Make sure hose, hose assemblies, and connection points are cleaned before installing.

Preventive Maintenance

Preventive maintenance consists of periodic inspection and correction of hose and hose assembly faults. In this process, you must check for leaks, wear, and deterioration. Special attention must be paid to hose or hose assemblies and clamps.

Checking For Leaks

Hose or hose assemblies should be replaced when leaks are found to be caused by damage to any part of a hose or hose assembly; poor seating or damaged threads of the socket or nipple assembly, which causes

the fitting to leak; or excessive torque. If a leak appears in the swivel nut area, check that the swivel nut is properly torqued. If necessary, disconnect fitting and check for contamination or damage. If the leak persists after cleaning, and the swivel nut is properly torqued, replace the hose assembly.

Checking For Wear and Deterioration

Check hose and hose assemblies for signs of wear and deterioration. Replace any hose or hose assembly when a chafe guard appears worn or shows signs of cracking; when a firesleeve is worn through, torn, cut, or oil soaked; when hose or hose assembly has weather protective coatings or sleeveings that are worn, cracked, or torn, thus exposing the hose or hose assemblies to corrosion.

Checking Hose or Hose Assembly Installations

Check hose or hose assembly installations carefully. Proper routing and clamping in accordance with applicable MIM is mandatory. If retaining wires on swivel nuts are backed out, replace the hose assembly. Look for kinks or twists. Observe lay line, if possible. A kinked hose or hose assembly must be replaced. A twisted hose or hose assembly may be relieved by loosening clamps and swivel nuts, and then straightening the hose by hand. Retorque the swivel nuts and tighten the clamps. A preformed hose, or hose assembly, may have a smaller bend radius. Do not attempt to straighten preformed hose or hose assemblies. Excessive bends or signs of chafing may be due to loose, oversized, or worn clamps. Replace oversized or worn clamps, and tighten the clamp without squeezing the hose.

Checking Clamps

You should check the clamps to make sure they are the correct type and size, that the position of the hose is correct within the clamp, and that the cushion material is positioned correctly. Reposition hose and clamps as needed. Cushion material should NOT lodge between end tabs of a closed clamp. Do NOT use clamps with fuel-resistant cushioning unnecessarily, as this type of cushioning material deteriorates rapidly when exposed to air.

Removing Hose Assemblies

Hose or hose assembly removal procedures must include contamination control procedures as well as

actual removal procedures to prevent contamination to the opened system.

CONTAMINATION CONTROL PROCEDURES.—Perform contamination control procedures before removing any hose or hose assemblies. You should use approved solvents and clean, lint-free cloths to clean the affected area and wipe down fittings to remove excessive contaminants. Use a suitable container to catch spilled fluid. Have replacement hose, hose assemblies, or protective closures on hand for installation when you disconnect hose or hose assemblies. If hose replacement is not practical, cap or plug hose or hose assembly ends immediately after disconnecting.

REMOVAL PROCEDURES.—Once contamination control has been accomplished, you can begin removal of hose and hose assemblies. Remove all supporting clamps from hose or hose assembly. Remove lockwire (if present) from swivel nuts. Turn swivel nuts only to disconnect hose assembly. Loosen nuts carefully to avoid damage. Disconnect the hose assembly by using two open-end wrenches. One is to grip and prevent turning of the fitting to which the hose assembly is connected, and the other is to loosen the swivel nut.

Hose and hose assemblies (particularly Teflon®) have a tendency to become set to shape in service. Some Teflon® hose assemblies are deliberately preformed during the fabrication process. Do not attempt to straighten a preformed hose. Protect the preformed areas from distortion by a restrainer. The restrainer may be of wire, metal, plastic forms, or any other suitable device to retain the preformed configuration. Install the protective closures to seal open parts of hydraulic lines and ends of removed hose or hose assemblies.

Installing Hose Assemblies

When you install hose or hose assemblies, it is important that you follow certain practices or procedures to prevent premature failure of hose or hose assembly or possible injury. Before you begin actual installation procedures, there are guidelines you should remember about installing hose or hose assemblies. The replacement hose or hose assembly must be a duplicate of the one removed in length, outside diameter, material, type, contour, and associated markings.

Only fluid conforming to MIL-H-5606, MIL-H-83282, or MIL-H-81019 is to be used on

hydraulic or pneumatic hose installations. Do **not** use oil of any type on self-sealing hose as an aid to installation. Compatible oil, approved for the purpose, may be used on all other types of fuel, oil, and coolant hose installations.

When you install or handle hose or hose assemblies, you can sustain injuries to your hands or damage to the hose if it is kinked. You should take care to prevent situations where injuries or kinking can occur. A hose that is bent to a smaller radius than specified might cause kinking. See table 10-7.

A preformed hose assembly, or one that has become set-to-shape of its operating position, is straightened or handled without a protective restraint. A

hose or hose assembly that is twisted during handling, removal, or installation can easily cause kinking.

PREINSTALLATION PROCEDURES.—

Check hose or hose assembly before installing it to make sure that identification bands and protective closures are present as required after proof pressure testing. Inspect hose for proper type and size, and for aging (signs of deterioration such as cracks, discoloration, hardening, weather checking, or fungus). Check the braid for two or more broken wires per plait, or more than six broken wires per linear foot. Inspect for broken wires where kinking is suspected. Evidence of internal restriction of tube due to collapse, kinking, wire-braid puncture, or other damage can be found by

Table 10-7.—Hose Minimum Bend Data

RUBBER HOSE						TEFLON® HOSE					
LOW PRESSURE MIL-H-5593		MED PRESSURE MIL-H-8794		MED PRESSURE LTWT MIL-H-83797		HIGH PRESSURE MIL-H-8788		MED PRESSURE MIL-H-27267		HIGH PRESSURE MIL-H-83298	
HOSE DASH NO.	MINIMUM BEND RADIUS (INCHES)	HOSE DASH NO.	MINIMUM BEND RADIUS (INCHES)	HOSE DASH NO.	MINIMUM BEND RADIUS (INCHES)	HOSE DASH NO.	MINIMUM BEND RADIUS (INCHES)	HOSE DASH NO.	MINIMUM BEND RADIUS (INCHES)	HOSE DASH NO.	MINIMUM BEND RADIUS (INCHES)
2	2.00	2	—	2	—	2	—	2	—	2	—
3	2.00	3	3.00	3	1.75	3	—	3	2.00	3	—
4	4.00	4	3.00	4	2.00	4	3.00	4	2.00	4	3.00
5	—	5	3.38	5	2.25	5	3.38	5	2.00	5	—
6	4.00	6	4.00	6	2.50	6	5.00	6	4.00	6	5.00
8	6.00	8	4.62	8	3.50	8	5.75	8	4.62	8	5.75
10	6.00	10	5.50	10	4.00	10	6.50	10	5.50	10	6.50
		12	6.50	12	4.50	12	7.75	12	6.50	12	7.75
		16	7.38	16	5.50	16	9.62	16	9.00	16	9.62
		20	9.00	20	8.00					20	12.00
		24	11.00	24	9.00	*16Z	7.38	*16Z	7.38		
		32	13.25	32	12.50	*20Z	11.00	*20Z	11.00		
		40	24.00			*24Z	14.00	*24Z	14.00		
		48	33.00								

Z—Designated two stainless steel wire braids.
NOTE: Bend Radius for MIL-H-600 and MIL-H-7938 hose shall not be less than 12 times the inside diameter of the hose.

using one of the following methods of inspection: For straight hose assembly, insert a light at one end and visually inspect from the opposite end. For elbow fitting on both ends (practical for larger sizes only), insert flexible inspection light into one end and visually inspect from the opposite end using a small, angled, dental-type mirror. Inspect for any separation of covers or braids from inner tube, or from adjacent covers or braids. Look for flaring or fraying of braid. Look for blisters, bubbles, or bulging. Inspect for corrosion. A hose that has carbon steel wire braid is subject to corrosion, which may be detected as brownish rust coloration penetrating the outer braid.

Inspect end fittings for proper type and size, corrosion and cleanliness, nicks, scratches, or other damage to the finish that affects corrosion resistance. Look for damage to threaded areas, damage to cone-seat sealing surfaces, damage to flange fittings, warping of flange, and for nicks or scratches on the sealing surface or gasket.

INSTALLATION PROCEDURES.—Remove the protective closures from hydraulic lines, hose, or hose assemblies. When possible, install hose or hose assemblies so that identification markings are visible. Install hose or hose assemblies without twisting, chafing, or overbending (fig. 10-20).

Observe bend radius in table 10-7. Greater bend-radius is preferred where possible. Install hose or hose assemblies with a slight bow or slack to compensate for contraction pressure on the line (fig. 10-21).

When connecting hose or hose assemblies to an engine or an engine-mounted accessory, provide 1 1/2 inches of slack or a suitable bend between the last point of support and the engine or accessory attachment. Fingertighten swivel connector nuts to avoid stripping threaded areas of fittings. Before applying final torque to end fittings, make sure hose assemblies are properly

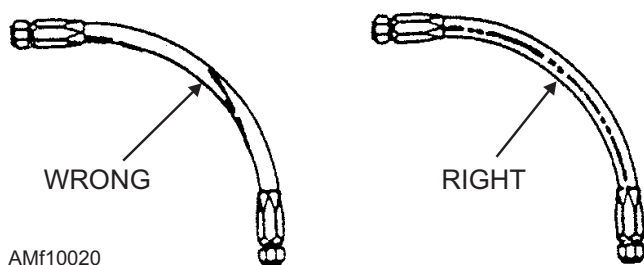

Figure 10-20.—Hose twist.

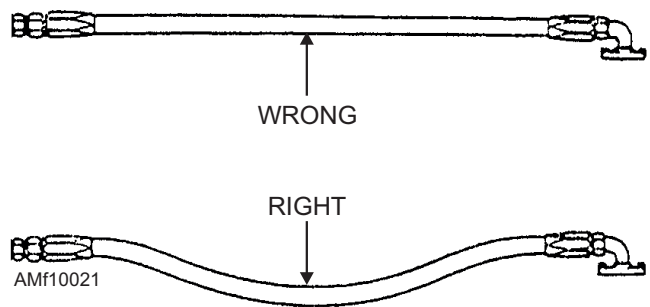

Figure 10-21.—Hose slack.

aligned and free of twists and kinks. Complete tightening by using torque values specified in applicable MIM. Table 10-8 is a guide for installation torque of flared and flareless fittings.

Table 10-8.—Swivel Nut Installation Torque (Inch-Pound) for Flared and Flareless Fittings

HOSE SIZE	STEEL		ALUMINUM	
	MIN	MAX	MIN	MAX
2	75	85	20	30
3	95	105	25	35
4	135	145	50	65
5	170	190	70	90
6	215	245	110	130
8	430	470	230	260
10	620	680	330	360
12	855	945	460	500
16	1140	1260	640	700
20	1520	1680	800	900
24	1900	2100	800	900
32	2660	2940	1800	2000

NOTE: Torque values based on lubrication with fluid MIL-H-5606 or MIL-H-83282 prior to installation.

Hold fitting stationary with one wrench, and use torque wrench to tighten swivel nut. When applying final torque, hold hose manually to prevent rotation and scoring of the fitting's sealing surface. Lockwire the swivel nut (if applicable). Support flexible hose or hose assemblies by routing and clamping hose or hose

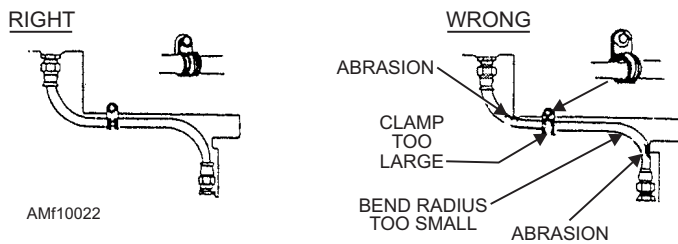

Figure 10-22.—Hose clamp mounting.

assembly securely to avoid abrasion and kinking where flexing occurs (fig. 10-22).

Overtightening clamps will squeeze or deform hose. Cushion-type clamps should be used to prevent hose chafing. See figure 10-23.

Make sure support clamps do not restrict hose travel or subject hose or hose assembly to tension, torsion, compression, or shear-stress during flexing cycles. Where flexing is required in an installation, bend the hose in the same plane of movement to avoid twisting. Ensure that the minimum bend radius is greater by a factor of "N" than the minimum bend radius for a nonflexing hose for hose assemblies required to flex at a bend (fig. 10-24).

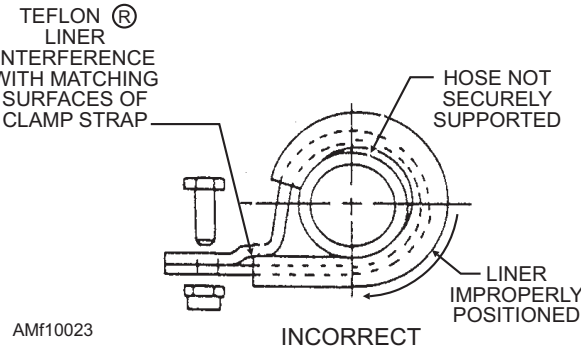
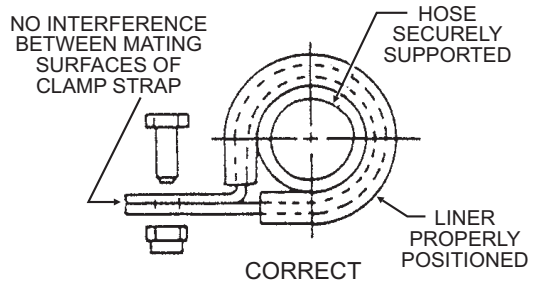

Figure 10-23.—Clamp installation.

Age Control and Service Life

Hose or hose assemblies fabricated from age-sensitive materials are subject to age control. The

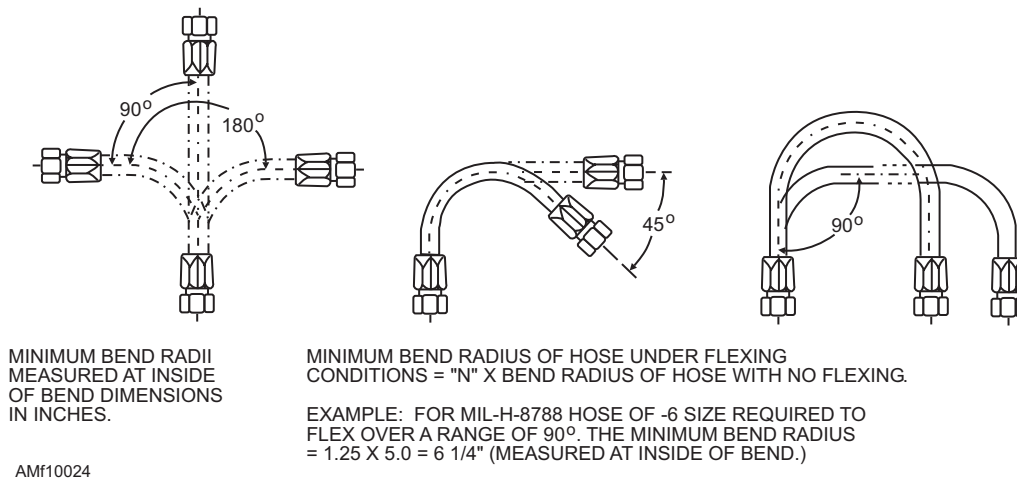
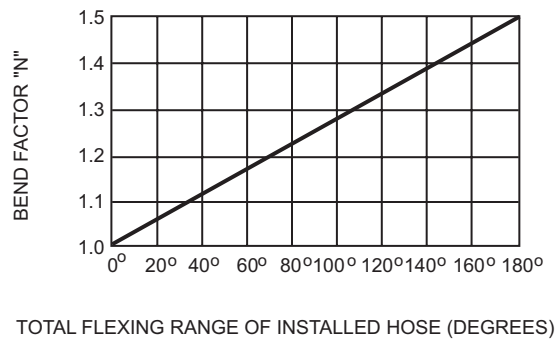

Figure 10-24.—"N" factor for flexing bends.

following definitions are provided to clarify age control, acceptance life, shelf life, and service life:

- Age control—The efforts made during manufacture, purchase, and the storage of age-sensitive items and parts made from natural or synthetic rubber materials to assure conformance to the applicable material and performance specifications. Age control is further defined in terms of acceptance life and shelf life.

- Acceptance life—The period of time from cure date to the procuring activity's (organizational-, intermediate-, or depot-level activity) date of acceptance.

- Shelf life—The period of time from the date of acceptance or delivery by the organizational-, intermediate-, or depot-level activity to the date of use.

- Service life—The period of time from the date of installation to the date of removal. Installation date of the hose or hose assemblies must be identified by a tag. See figure 10-5.

Acceptance Life and Shelf Life for Synthetic Rubber Hose and Hose Assemblies

The acceptance life (MIL-STD-1523) and shelf life (DOD 4140.27M) for synthetic rubber hose and hose assemblies are established as follows:

- Synthetic rubber hose, bulk or assembly, must not exceed 8 years (32 quarters) from the cure date, which must be stenciled on the rubber covering of the bulk hose or provided on an identification band on the metal braid hose or on the hose assemblies.

- Synthetic rubber hose and hose assemblies must not exceed 5 years (20 quarters) from the date of delivery to the organizational-, intermediate-, or depot-level activity. The repair activity maintains a record of delivery dates for bulk hose and hose assemblies to monitor shelf life expiration dates.

NOTE: Teflon® (PTFE) rubber hose and hose assemblies do not have shelf life limitations.

Service Life for Synthetic Rubber Hose Assemblies

Service life is 7 years (28 quarters) for synthetic rubber hoses in critical applications; that is, medium- and high-pressure synthetic rubber hoses exposed to heat, weather, or fuel.

NOTE: Service life for Teflon® (PTFE) hose assemblies is determined by Cognizant Field Activity

and may be on-conditional replacement or hard-time replacement.

Rejection Standards

Rejection and replacement of hose or hose assemblies after inspections are based on the standards normally specified in the applicable maintenance instruction manual, maintenance requirement cards, and depot-level specifications. Where rejection standards are not specifically outlined or if doubt exists as to the acceptability of a hose or hose assembly, replace the hose or hose assembly.

NOTE: Teflon® (PTFE) hose assemblies are replaced only on a conditional basis.

Storage

Hose and hose assemblies fabricated from age-sensitive materials are subject to deterioration by oxygen, ozone, sunlight, heat, moisture, or other environmental factors. These types of hoses and hose assemblies should be stored in a dark, cool, dry place protected from circulating air, sunlight, fuel, oil, water, dust, and ozone (ozone may be generated in an atmosphere where electricity is discharged through oxygen or ambient air). Store hose or hose assemblies by sealing both ends of bulk hose. Cap or plug each hose or hose assembly. Store hose or hose assemblies on racks that support and protect them. Store hose or hose assemblies so that the oldest items are issued first.

CAUTION

Do not store hose or hose assemblies in piles. Improper storage will cause accelerated deterioration due to both heat and moisture factors.

Q10-1. What are the two basic types of hose used in military aircraft and related equipment?

Q10-2. What material is used to cover a Teflon® hose?

Q10-3. How is a synthetic rubber hose identified?

Q10-4. A hose fitting consists of what separate parts?

Q10-5. What color is an aluminum alloy 2024 hose fitting?

Q10-6. How are commercially manufactured hose assemblies identified?

Q10-7. How are locally fabricated hose assemblies identified?

Q10-8. What type of cover is used to protect a hose assembly that is subjected to high temperatures?

Q10-9. All hose assemblies manufactured in a shop must have what test completed before they are installed on an aircraft?

Q10-10. What is the first thing you must do when you discover a swivel nut leaking?

Q10-11. What is the acceptance life for a synthetic rubber hose assembly?

Q10-12. What is the service life of a synthetic rubber hose assembly that is exposed to the weather, fuel, or heat?

TUBING ASSEMBLIES

LEARNING OBJECTIVES: Identify the various types of tubing and tubing assemblies. Recognize materials, tools, equipment, and testing procedures used in tubing assemblies. Recognize maintenance procedures for tubing assemblies.

Table 10-9.—Corrosion-Resistant Steel Tubing

Specification Tubing Material	Type	Condition	General Usage and Applications
MIL-T-7081	6061 A1		Specification covers annealed and three heat-treated tempers used mostly in O-annealed and T-6. Has good workability. The 6061-T6 is used in hydraulic/pneumatic 3000-psi systems.
MIL-T-8506 18-8 Corrosion-Resistant Steel (CRES)	304	Annealed	Low-pressure applications such as fuel lines. Unsatisfactory for high-pressure hydraulic lines. Has high degree of resistance to corrosion.
MIL-T-8504 18-8 CRES	304	Annealed	Unsatisfactory for welding, brazing or exposure to temperatures higher than 800°F. Used in high-pressure hydraulic/pneumatic systems.
MIL-T-8606 18-8 CRES	304L (low carbon) 321 347	Annealed	Hydraulic/mechanical applications. Has high resistance to corrosion and high temperatures up to 1500°F. Suitable for applications requiring welding/brazing. Type II intended for high-pressure hydraulic applications, using brazed sleeve joints.
MIL-T-6845 18-8 CRES	304	1/8H	Used in high-pressure hydraulic/pneumatic systems. Unsuitable for welding/brazing applications or exposure to temperatures above 800°F.
MIL-T-8973 18-8 CRES	304L (low carbon) 316L (low carbon) 321 347	1/8H	Used in high-pressure hydraulic/pneumatic systems assembled with brazed sleeve joints. Suitable for use in moderately corrosive or oxidizing environments, temperatures to 1200°F. Weldable.
MIL-T-5695 18-8 CRES	304	1/4H 1/2H	Used for aircraft structural parts or similar applications not requiring sharp bends or flaring. Unsatisfactory for welding other than resistance weld.
MIL-T-8808 18-8 CRES	321 347	Annealed	Aircraft hydraulic quality, used in high-pressure hydraulic/pneumatic systems. Most often used in these systems requiring brazing/welding.

Tubing assemblies are used to transport liquids or gas (usually under pressure) between various components of the aircraft system. Tube assemblies are used in aircraft for fuel, oil, oxidizer, coolant, breathing oxygen, instruments, hydraulic, and vent lines. You must be familiar with the procedures for testing and fabricating tubing assemblies, and you must recognize the various tools and equipment and how to identify the different uses of tubing in naval aircraft. Tube assemblies are fabricated from rigid tubing and associated fittings.

RIGID TUBING

The tubing used in the manufacture of rigid tubing assemblies is sized by outside diameter (OD) and wall thickness. Outside diameter sizes are in sixteenth-inch increments; the number of the tube indicates its size in sixteenths of an inch. Thus, No. 6 tubing is 6/16 or 3/8 inch; No. 8 tubing is 8/16 or 1/2 inch, etc. Wall thickness is specified in thousandths of an inch. The most common types of tubing are the corrosion-resistant steel tubing for high pressure and the aluminum alloy tubing for high pressure and general-purpose.

Corrosion-Resistant Steel Tubing

Corrosion-resistant steel tubing (CRES) is used in high-pressure hydraulic systems (3,000 psi and above) such as landing gear, wing flaps, and brakes. The tubing does not have to be annealed for flaring or forming. The flared section is strengthened by cold working and consequent strain hardening. Table 10-9 lists the most commonly used corrosion-resistant steel tubing in naval aircraft and includes some of the designations by which the corrosion steel tubing is known. Application notes are intended as guidelines.

Corrosion-resistant steel tube assemblies fabricated with corrosion-resistant steel tubing MIL-T-6845 are authorized for repair or replacement for any line provided no attempt is made to weld or braze the tubing. MIL-T-6845 tubing is not to be substituted for British DTD-5016 annealed stainless steel tubing.

Aluminum Alloy Tubing











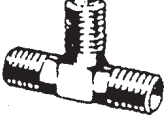
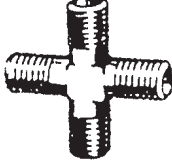

Aluminum alloy tubing is used for both high-pressure and general-purpose lines. Table 10-10 lists the most commonly used aluminum alloy tubing

Table 10-10.—Aluminum Alloy Tubing Applications

Old Specification	New Specification	Type	General Usage and Applications
WW-T-383	WW-T-700/1	1100 - 0 -H12 -H14 -H16 -H18	<div style="border: 1px solid black; padding: 5px; text-align: center; margin: 0 auto; width: fit-content;">CAUTION</div> <p>Tubing conforming to Federal Specification WW-T-700/1 shall not be used in hydraulic systems.</p> <p>Specification covers tempers from annealed to full-hard. Used mostly in O-annealed condition. Good formability. Used where high strength is not necessary, as in low- or negative-pressure (nonhydraulic) lines.</p>
WW-T-787	WW-T-700/4	5052 - 0 -H32 -H34 -H36 -H38	Specification covers tempers from annealed to full-hard. Used mostly in O-annealed condition. Has good workability. Used in medium-pressure systems (1500 psi max.)
WW-T-789	WW-T-700/6	6061 - 0 - T4 -T6 ¹	Specification covers annealed and three heat-treated tempers. Used mostly in O-annealed and T-6. Has good workability. Tubing conforming to Federal Specification WW-T-700/6 shall not be used in hydraulic systems.
<p>¹Only 6061-T6 is of sufficient strength to use in the repair of aluminum tubing systems. In an emergency, the other alloys of aluminum may be used with AN fittings to make temporary repairs only.</p>			

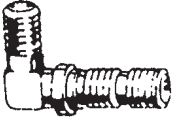
and its applications. Use of aluminum alloy tubing is limited in certain areas of airborne hydraulic systems by MIL-H-5440. Refer to the applicable drawing and the illustrated parts breakdown to determine the correct tubing for a particular system. Aluminum alloy tube

assemblies fabricated with aluminum alloy tubing 6061-T6 are authorized for repair or replacement for any aluminum line. MIL-T-6845 CRES tubing (304-1/8H) is a suitable substitute for all aluminum alloy tubing when 6061-T6 is unavailable.

<p>MS 21904- ELBOW</p>  <p>FLARELESS TUBE 90 DEGREE</p>	<p>MS 21905- TEE</p>  <p>FLARELESS TUBE</p>	<p>MS 21906- CROSS</p>  <p>FLARELESS TUBE</p>	<p>MS 21902- UNION</p>  <p>FLARELESS TUBE</p>
<p>MS 21900- ADAPTER</p>  <p>FLARELESS TO AN FLARED TUBE</p>	<p>MS 21916- REDUCER</p>  <p>FLARELESS TUBE EXTERNAL THREAD</p>	<p>MS 21913- PLUG</p>  <p>FLARELESS TUBE</p>	<p>MS 21914- CAP ASSEMBLY (STEEL ONLY)</p>  <p>FLARELESS TUBE PRESSURE SEAL</p>
<p>MS 21915- BUSHING</p>  <p>FLARELESS TUBE SCREW THREAD EXPANDER</p>	<p>MS 21907- ELBOW</p>  <p>FLARELESS TUBE BULKHEAD UNIVERSAL 45 DEGREE</p>	<p>MS 21908- ELBOW</p>  <p>FLARELESS TUBE BULKHEAD UNIVERSAL 90 DEGREE</p>	<p>MS 21903- UNION (LONG TYPE)</p>  <p>FLARELESS TUBE BULKHEAD AND UNIVERSAL</p>
<p>MS 21901- ADAPTER (LONG TYPE)</p>  <p>FLARELESS TUBE TO AN FLARED TUBE BULKHEAD</p>	<p>MS 21921- NUT</p>  <p>FLARELESS TUBE NUT USE ONLY WITH 21922 SLEEVE</p>	<p>MS 21922- SLEEVE (STEEL ONLY)</p>  <p>FLARELESS TUBE SLEEVE USE ONLY WITH 21921 NUT</p>	

EXAMPLE OF CODE:

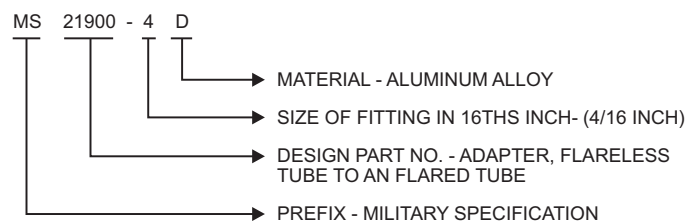

AMf10025

Figure 10-25.—Typical styles of MS fittings.

Other Tubing

Corrosion-resistant steel 21-6-9 and titanium alloy 3AL-2.5V are presently being incorporated into new model aircraft. Repair and fabrication of assemblies using these materials may require special procedures. Refer to the applicable maintenance directives for specific details.









TUBE FITTINGS

Fittings for tube connections are made of aluminum alloy, titanium steel, corrosion-resistant steel, brass, and bronze. Fittings are made in many configurations and styles. The usual classifications are flared-tube fittings, flareless-tube fittings, brazed, welded, and swaged fittings (figs. 10-25 through 10-28). Refer to table 10-11, for identification of fittings.

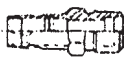
<p>AN-832- UNION</p>  <p>FLARED TUBE BULKHEAD AND UNIVERSAL</p>	<p>AN-833- ELBOW</p>  <p>FLARED TUBE BULKHEAD UNIVERSAL 90°</p>	<p>AN-834 TEE</p>  <p>FLARED TUBE BULKHEAD AND UNIVERSAL</p>	<p>AN-837- ELBOW</p>  <p>FLARED TUBE AND UNIVERSAL 45°</p>
<p>AN-6289- NUT</p>  <p>FLARED TUBE UNIVERSAL FITTING</p>	<p>AN-825- TEE</p>  <p>FLARED TUBE PIPE THREAD ON SIDE</p>	<p>AN-826 TEE</p>  <p>FLARED TUBE PIPE THREAD ON RUN</p>	<p>AN-827- CROSS</p>  <p>FLARED TUBE</p>
<p>AN-824- TEE</p>  <p>FLARED TUBE</p>	<p>AN-821- ELBOW</p>  <p>FLARED TUBE 90°</p>	<p>AN-822- ELBOW</p>  <p>FLARED TUBE AND PIPE THREAD 90°</p>	<p>AN-815- UNION</p>  <p>FLARED TUBE</p>
<p>AN-894- BUSHING</p>  <p>SCREW THREAD EXPANDER</p>	<p>AN-775- BOLT</p>  <p>UNIVERSAL FITTING</p>	<p>AN-776- ELBOW</p>  <p>UNIVERSAL 90°</p>	<p>AN-929- CAP</p>  <p>PRESSURE SEAL FLARED TUBE FITTING</p>
<p>AN-806- PLUG</p>  <p>FLARED TUBE</p>	<p>AN-938- TEE</p>  <p>INTERNAL SCREW THREAD</p>	<p>AN-939- ELBOW</p>  <p>INTERNAL SCREW THREAD 90°</p>	<p>AN-941- ELBOW</p>  <p>INTERNAL SCREW THREAD 45°</p>

AMF10026

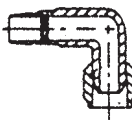
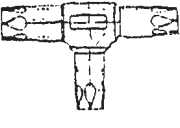
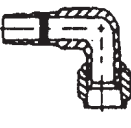
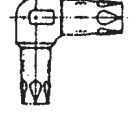
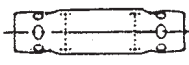
Figure 10-26.—Typical styles of AN fittings.

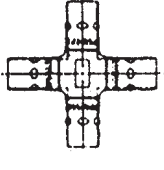
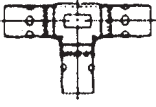
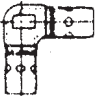
<p>D10006 NUT</p>  <p>FLARED AND FLARELESS</p>	<p>D10007 SLEEVE</p>  <p>FLARELESS</p>	<p>D10008 UNION</p>  <p>FLARELESS</p>	<p>D10010 SLEEVE</p>  <p>FLARED- FEMALE</p>
<p>D10011 UNION</p>  <p>FLARED- MALE</p>	<p>D10019 UNION</p>  <p>FLARELESS TO BULKHEAD</p>	<p>D10021A ADAPTER 90 DEGREE</p>  <p>FLARELESS</p>	<p>D10023 TEE</p>  <p>REDUCER</p>
<p>D10027A ADAPTER 90 DEGREE</p>  <p>FLARED 90 DEGREE</p>	<p>D10035 ELBOW</p>  <p>REDUCER 90 DEGREE</p>	<p>D10036 STANDARD UNION</p> 	<p>D10045 UNION</p>  <p>REDUCER</p>
<p>D10046 UNION</p>  <p>FLARED BULKHEAD</p>	<p>D9854 CROSS</p> 	<p>D9855 TEE</p> 	<p>D9856 ELBOW</p> 

AMf10027

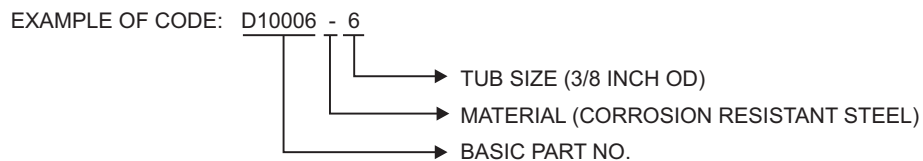

Figure 10-27.—Typical style of Permaswage fittings.



FABRICATION

Fabrication of tube assemblies consists of tube cuttings, deburring, bending, and tube joint preparation. The procedures in this chapter are for instructional purposes only. When fabricating tube

assemblies, refer to the *Aviation Hose and Tube Manual*, NA 01-1A-20.

Tube Cutting

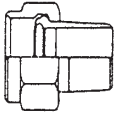
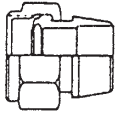
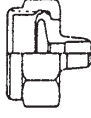
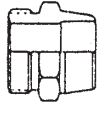
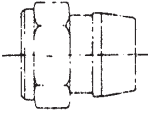
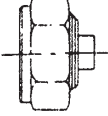
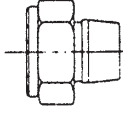
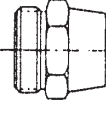
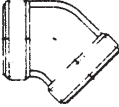
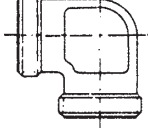
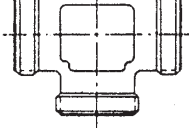
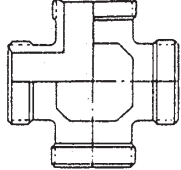
When you cut tubing, the objective is to produce a square end free from burrs. Tubing should be cut with

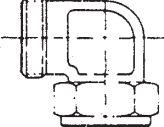
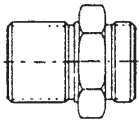
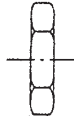
<p>MR44000 SWAGED TUBE SHOULDER</p>  <p>SIZES 03 THRU 12 STEEL</p>	<p>MR44000 SWAGED TUBE SHOULDER</p>  <p>SIZES 16 AND UP STEEL</p>	<p>MR44027 SWAGED TUBE SHOULDER</p>  <p>REDUCER STEEL</p>	<p>MR44100 SWAGED TUBE CONNECTOR</p>  <p>SIZES 03 THRU 24 STEEL</p>
<p>MR54040 SWAGED TUBE SHOULDER</p>  <p>SIZES 03 THRU 25 TITANIUM</p>	<p>R44117 CAP</p>  <p>SIZES 03 THRU 25 TITANIUM OR STEEL</p>	<p>MR54027 SWAGED TUBE SHOULDER</p>  <p>REDUCER TITANIUM</p>	<p>MR54100 SWAGED TUBE CONNECTOR</p>  <p>SIZES 03 THRU 25 TITANIUM</p>
<p>R44104 45 DEGREE ELBOW</p>  <p>SIZES 03 THRU 25 TITANIUM OR STEEL</p>	<p>R44106 90 DEGREE ELBOW</p>  <p>SIZES 03 THRU 25 TITANIUM OR STEEL</p>	<p>R44111 TEE</p>  <p>SIZES 03 THRU 25 TITANIUM OR STEEL</p>	<p>R44114 CROSS</p>  <p>SIZES 03 THRU 25 TITANIUM OR STEEL</p>
<p>R44129-45 45 DEGREE ELBOW</p>  <p>SIZES 03 THRU 25 TITANIUM OR STEEL</p>	<p>R44129-90 90 DEGREE ELBOW</p>  <p>SIZES 03 THRU 25 TITANIUM OR STEEL</p>	<p>R44358 BULKHEAD CONNECTOR</p>  <p>SIZES 03 THRU 25 TITANIUM OR STEEL</p>	<p>R44118 JAM NUT</p>  <p>SIZES 03 THRU 25 TITANIUM OR STEEL</p>

AMF10028

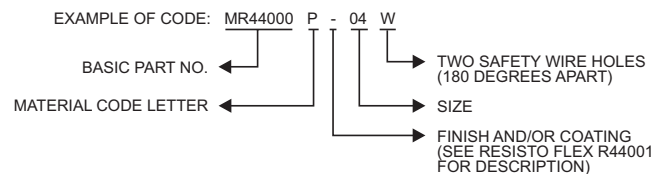

Figure 10-28.—Typical style of Dynatube fittings.

Table 10-11.—AN/MS Tube Fitting Color Codes

MATERIAL OR FINISH	COLOR
Aluminum Alloy	Blue
Carbon Steel	Black
Corrosion Resistant Steel	Natural
Aluminum-bronze	Cadmium Plate
Titanium	Natural to Grey, Depending on type and intended use.

a standard tube cutter, or the Permaswage chipless cutter.

STANDARD TUBE CUTTER.—Place the tube in cutter with cutting wheel at the point where the cut is to be made. Apply light pressure on tube by tightening adjusting knob. Too much pressure applied to the cutting wheel at one time may deform the tubing or cause excessive burrs. Rotate the cutter toward

its open side (fig. 10-29). As the cutter is rotated, adjust the tightening knob after each complete turn to maintain light pressure on the cutting wheel.

PERMASWAGE CHIPLESS CUTTER.—

Select the chipless cutter according to tubing size. Rotate cutter head to accept tubing in cutting position. Check to ensure the cutter ratchet is operating freely and the cutter wheel is clear of the cutter head opening (fig. 10-30).

Center the tubing on two rollers and cutting blade. Use the hex key provided with the kit to turn the drive screw in until the cutter wheel touches the tube. Tighten the drive screw one-eighth to one-fourth turn. Do not overtighten the drive screw. Overtightening can damage soft tubing or cause excessive wear or breakage of the cutter wheel in hard tubing. Swing ratchet handle back and forth through the available clearance until there is a noticeable ease of rotation. Avoid side force on cutter handle. Side force will cause the cutter wheel to break. Tighten the drive screw an additional one-eighth to one-fourth turn, and swing ratchet handle back and forth, retightening drive screw as needed until cut is completed.

If neither tube cutter (standard or Permaswage) is available, a fine-tooth hacksaw should be used to cut tubing. A convenient method for cutting tubing with a hacksaw is to place the tube in a flaring block and the clamp block in a vise. After cutting the tube with a hacksaw, remove all saw marks by filing the tube.

Tube Deburring

After you cut the tubing, remove all burrs and sharp edges from inside and outside of tube (fig. 10-31) with deburring tools. Clean out tubing. Make sure that no foreign particles remain. A Permaswage deburring tool

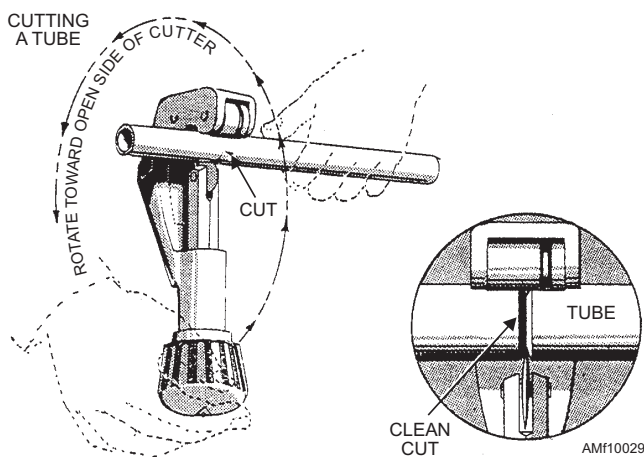

Figure 10-29.—Standard tube cutter.

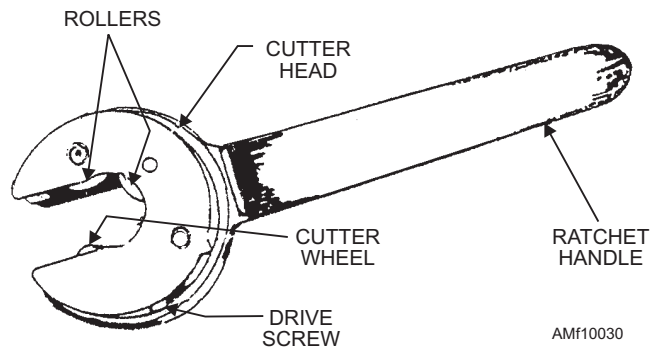

Figure 10-30.—Permaswage chipless cutter.

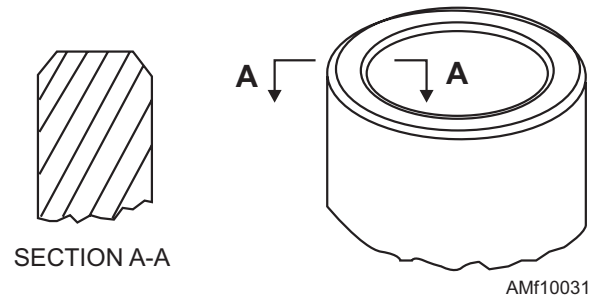

Figure 10-31.—Properly deburred tubing.

may be used to remove burrs from inside of tubing. Select deburring tool and stem subassembly (fig. 10-32) required for the size of tubing to be deburred. Lubricate the sliding collar on the end of elastic plug with light oil if necessary to get free movement. Engage threads and insert stem subassembly into cutter end of deburring tool by depressing the plunger, and screw stem subassembly into plunger until it bottoms and fingertightens. Check assembly deburring tool. Depress plunger and the plug. Outside diameter should be reduced to the same diameter as metal support collar on either end of elastic plug. Release plunger. Two distinct circumferential bumps will appear on elastic plug beyond outside diameter of metal support collars. Check the tube end for squareness. Check the elastic plug for wear and cleanliness. Replace worn or damaged elastic plug. Clean and lightly lubricate elastic plug with lubricant compatible to hydraulic fluid to be used in tubing. Grasp deburring tool in one hand with two fingers on collar and thumb on plunger. Depress plunger with thumb and insert elastic plug into

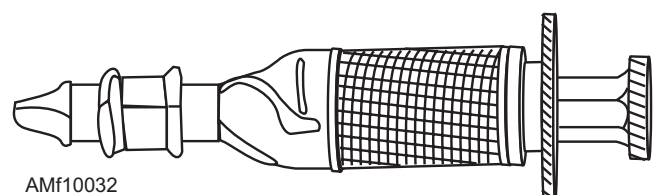

Figure 10-32.—Permaswage deburring foot (typical).

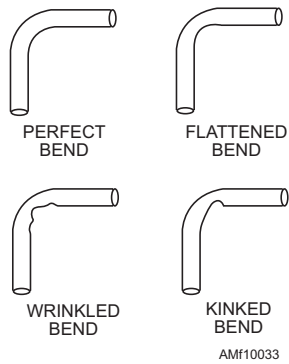

Figure 10-33.—Tubing bends.

tube opening until cutter is about 1/8 inch from tube end. If the plug fit is tight due to a large burr on ID of the tube, slowly rotate the plunger end of tool while gently pushing tool into the tube end. Release plunger to allow elastic plug to expand and seal tube opening to prevent chips from entering. Hold tube end and rotate knurled body of deburring tool in a clockwise direction while applying pressure to cutter. Continue rotating tool until resistance decreases, indicating all burrs have been removed from tube inside diameter (ID).

You should avoid excessive deburring, which can cause too deep a chamfer on tube ID. The chamfer should not exceed one-half wall thickness of tubing. Relax pressure and rotate deburring tool several times to produce a smooth surface. Without depressing plunger, ease deburring tool from tube until the first bulge of elastic plug is exposed. Wipe off the tube end and plug. Check the tube end to see if it is completely

deburred. If tube end appears satisfactory, without depressing plunger, remove deburring tool from tube. If tube end is not completely deburred, without depressing plunger, push deburring tool back into the tube and repeat all the steps.

Tube Bending

The objective in tube bending is to obtain a smooth bend without flattening the tube. Acceptable and unacceptable bends are shown in figure 10-33. Tube bending is usually done by using a mechanical or hand-operated tube bender. In an emergency, soft, nonheat-treated aluminum tubing smaller than 1/4 inch in diameter may be bent by hand to form the desired radius.

HAND TUBE BENDING.—The hand-operated tube bender, shown in figure 10-34, consists of a handle, radius block, clip, and a slide bar. The handle and slide bar are used as levers to provide the mechanical advantage necessary to bend tubing. The radius block is marked on degrees of bend ranging from 0 to 180 degrees. The slide bar has a mark that is lined up with the zero mark on the radius block. The tube is inserted in the tube bender, and after lining up the marks, the slide bar is moved around until the mark on the slide bar reaches the desired degree of bend on the radius block. See figure 10-34 for the six procedural steps in tube bending with the hand-operated tube bender.

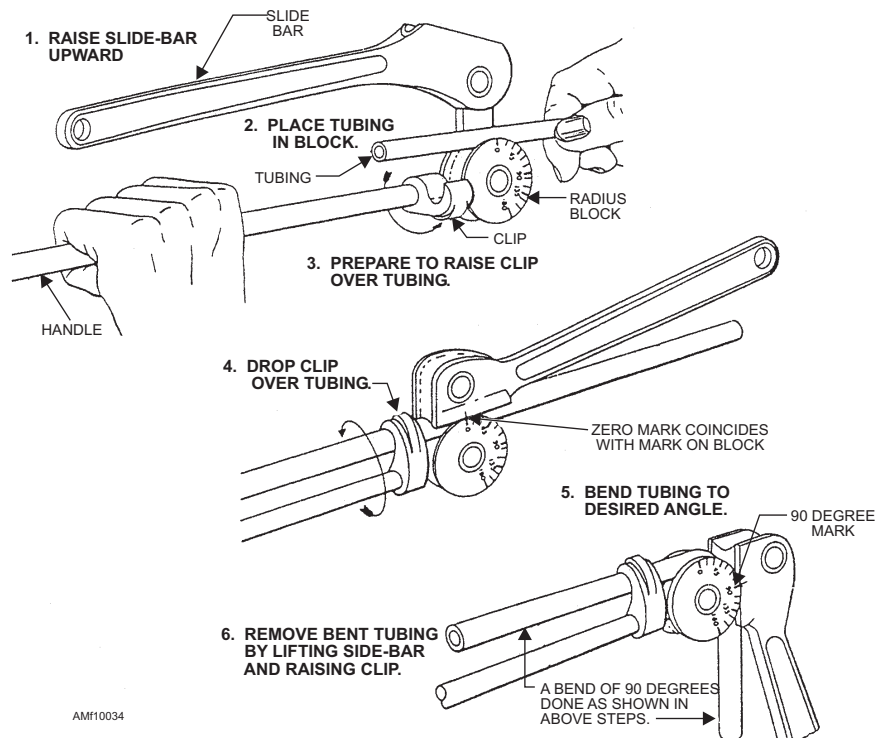

Figure 10-34.—Bending tubing with hand-operated tube bender.

MECHANICALLY OPERATED TUBE BENDER.

BENDER.—The tube bender, shown in figure 10-35, is issued as a kit. The kit contains the equipment necessary for bending tubing from 1/4 inch to 3/4 inch in diameter. This tube bender is designed for use with aircraft grade, high-strength, stainless-steel tubing, as well as all other metal tubing. It is designed to be fastened to a bench or tripod, and the base is formed to provide a secure grip in a vise.

The simple hand bender shown in figure 10-34 uses two handles as levers to provide the mechanical advantage necessary to bend the tubing, while the mechanically operated tube bender employs a hand crank and gears. The forming die is keyed to the drive gear and secured by a screw (fig. 10-35).

The forming die on the mechanical tube bender is calibrated in degrees similar to the radius block of the hand-type bender. A length of replacement tubing may be bent to a specified number of degrees or it may be bent to duplicate the bend in the damaged tube or pattern. Duplicating the bend of a damaged tube or pattern is accomplished by laying the pattern on top of the tube being bent and slowly bending the new tube to the required bend.

NOTE: Certain types of tubing are more elastic than others. It may be necessary to bend the tube past the required bend to allow for springback.

Before bending aluminum alloy tubing, it should be packed with fusible alloy Federal Specification QQ-F-838. In an emergency, when aluminum alloy QQ-F-838 is not available, aluminum alloy tubing may be packed with shot or sand and both ends closed with protective closures before bending. Where sand or fusible alloy is used, wash or blow out all particles after the tubing has been bent. Particles of aluminum alloy or sand can cause serious damage to component parts.

Tube Joint Preparation

The two major tube joints are the flared fittings and flareless fittings. Preparations for these tube joints differ.

FLARED FITTINGS.—There are two types of flared tubing joints—the single-flared joint and the double-flared joint. The single-flared tube joint is used on all sizes of steel tubing and 5052 aluminum alloy tubing that conforms to Federal Specification WW-T-700/6 with 1/2 inch or larger outside diameter. Use the tube flaring tool (fig. 10-36) to prepare tube ends for flaring. Check tube ends for roundness, square

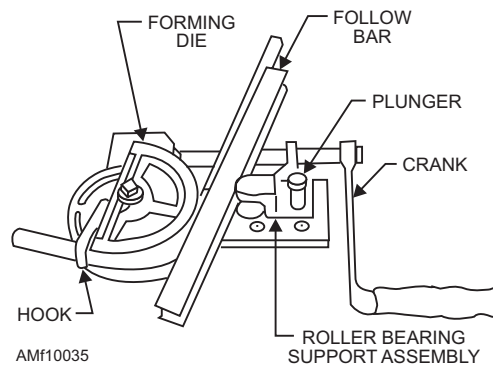

Figure 10-35.—Mechanically operated tube bender.

cut, cleanliness, and no draw marks or scratches. Draw marks can spread and split the tube when it is flared. Use a deburring tool to remove burrs from the inside and outside of the tubing. Remove filings, chips, and grit from inside the tube. Clean the tube. Slip the fitting nut and sleeve onto the tube. Place the tube into the proper size hole in the grip die. Make sure the end of the tube extends 1/64 inch above the surface of the grip die. Center the plunger over the end of the tube and tighten the yoke setscrew to secure the tube in the grip die and hold the yoke in place. Strike the top of the plunger several light blows with a hammer or mallet, turning the plunger a half turn after each blow. Loosen the setscrew and remove the tube from the grip die. Check to make sure that no cracks are evident and that the flared end of the tube is no larger than the largest diameter of the sleeve being used.

The double-flare tube joint is used on all 5052 aluminum alloy tubes with less than 1/2-inch outside diameter, except when used with NAS 590 series tube fittings and NAS 591 connectors or NAS 593 connectors. Aluminum alloy tubing used in low-pressure oxygen systems or corrosion-resistant steel used in brake systems must be double flared. Double flare reduces the chance of cutting the flare by overtightening. When fabricating oxygen lines, make

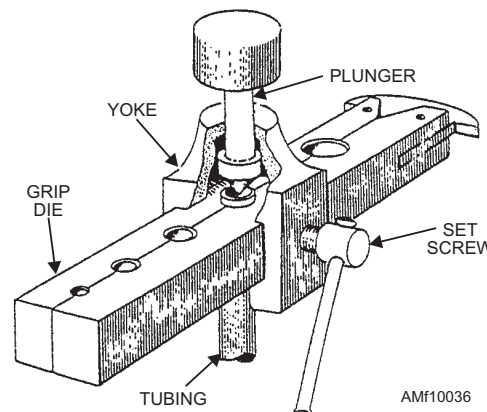

Figure 10-36.—Tube flaring tool (single-flare).

sure that all tube material and tools are kept free of oil and grease. Use the tube flaring tool (fig. 10-37) to prepare tube ends. Check tube end for roundness, square cut, cleanliness, and make sure there are no draw marks or scratches. Draw marks can split the tubing when it is flared.

Use a deburring tool to remove burrs from the inside and outside of tube. Remove filings, chips, and grit from inside the tube. Clean the tube. Select the proper size die blocks, and place one-half of the die block into the flaring tool body with the countersunk end towards the ram guide. Install the nut and sleeve, and lay the tube in the die block with 1/2 inch protruding beyond countersunk end. Place the other half of the die block into the tool body, close latch plate, and tighten the clamp nuts fingertight. Insert the upset flare punch in the tool body with the gauge end toward the die blocks. The upset flare punch has one end counterbored or recessed to gauge the amount of tubing needed to form a double lap flare. Insert the ram and tap lightly with a hammer or mallet until the upset flare punch contacts the die blocks, and the die blocks are set against the stop plate on the bottom. Use a wrench to tighten the latch plate nuts alternately, beginning with the closed side, to prevent distortion of the tool. Reverse the upset flare punch; insert the upset flare punch and ram into the tool body. Tap lightly with a hammer or mallet until the upset flare punch contacts the die blocks. Remove the upset flare punch and ram. Insert the finishing flare punch and ram. Tap the ram lightly until a good seat is formed (fig. 10-38). Check the seat at intervals during the finishing operation to avoid overseating.

FLARELESS FITTINGS.—Preparing tube ends for flareless fitting requires a presetting operation whereby the sleeve is set onto the tubing. Presetting is necessary to form the seal between the sleeve and the tube without damaging the connector. Presetting should

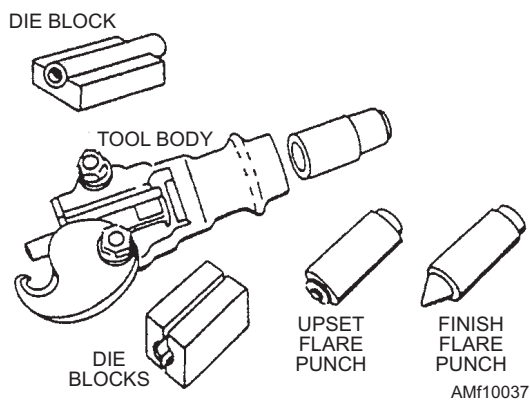

Figure 10-37.—Tube flaring tool (double-flare).

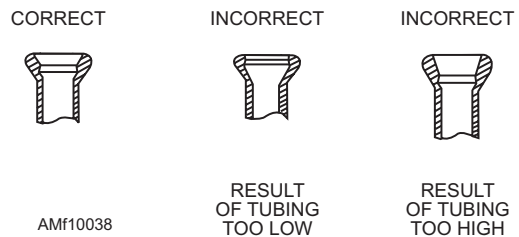

Figure 10-38.—Tube position and resulting flare.

always be accomplished with a presetting tool, such as the one shown in figure 10-39. These tools are machined from tool steel and hardened so that they may be used with a minimum of distortion and wear.

NOTE: A flareless-tube connector may be used as a presetting tool in case of an emergency. However, when connectors are used as presetting tools, aluminum connectors should be used only once, and steel connectors should not be used more than five times.

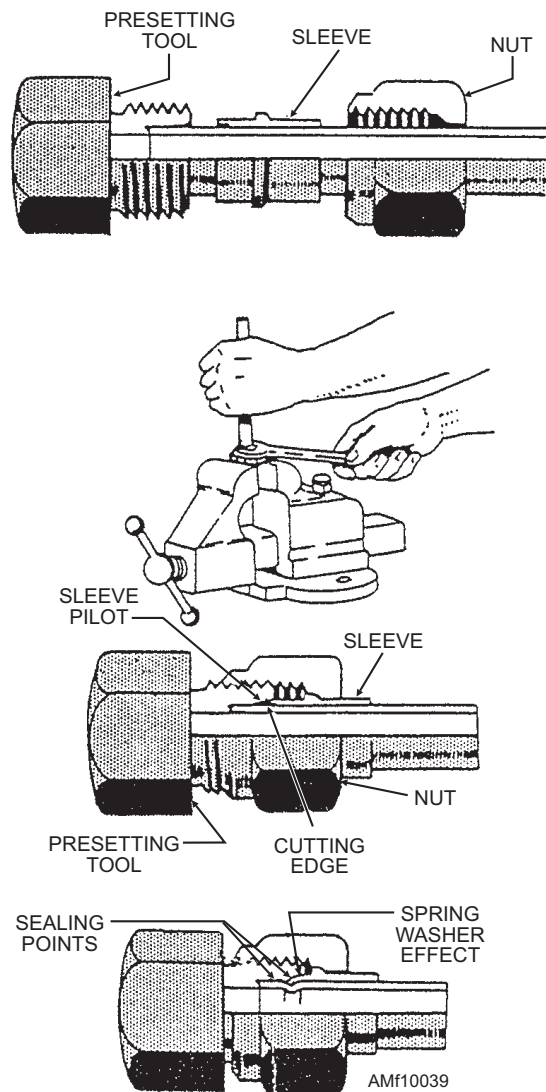

Figure 10-39.—Presetting flareless-tube assembly.

Special procedures are used in the presetting operation. Select the correct size presetting tool or a flareless fitting body. Clamp the presetting tool or flareless fitting body in a vise. Slide a nut and then a sleeve onto the tube, and make sure the pilot and cutting edge of the sleeve points toward the end of tube. Select the lubricant from table 10-12, and lubricate fitting threads, tool seat, and shoulder sleeve. Place the tube end firmly against the bottom of the presetting tool seat, while slowly screwing the nut onto the tool threads with a wrench until the tube cannot be rotated with thumb and fingers. At this point the cutting edge of the sleeve is gripping the tube and preventing tube rotation; the fitting is ready for the final tightening force needed to set the sleeve on the tube. Tighten the nut to the number of turns specified in *Aviation Hose and Tube Manual*, NAVAIR 01-1A-20.

Table 10-12.—Thread Lubricants

SYSTEM	LUBRICANT
Hydraulic	Specification MIL-H-5606
Fuel	Specification MIL-H-5606
Oil	Specification MIL-O-6032 or MIL-L-23699
Freon	Specification MIL-L-6085A
Pneumatic	Specification MIL-G-4343
Oxygen	Specification MIL-T-27730A

After presetting, unscrew the nut from the presetting tool or flareless fitting body; check the sleeve and tube (fig. 10-40). Sleeve cutting lip should be imbedded into the tube's outside diameter between 0.003 inch and 0.008 inch, depending on size and tubing material. A lip of tube material will be raised under the sleeve pilot. The sleeve pilot should contact or be quite close to the outside diameter of tube. The tube projection from the sleeve pilot to the tube end should be as listed in table 10-13. The sleeve should be bowed slightly. The sleeve may rotate on tube and have a maximum lengthwise movement of 1/64 inch. The sealing surface of the sleeve, which contacts the 24-degree angle of fitting body seat, should be smooth, free from scores, and should not show lengthwise or circular cracks. Cracking cracks in finish are not harmful to safety or function of fitting. Minimum internal tube diameter should not be less than values shown in table 10-14.

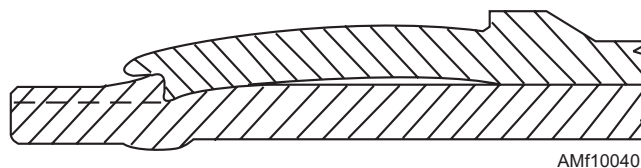

Figure 10-40.—Preset sleeve.

Table 10-13.—Tube Projection from Sleeve Pilot

TUBE SIZE	*APPROXIMATE TUBE PROJECTION-INCHES
2	7/64
3	7/64
4	7/64
5	5/32
6	11/64
8	3/16
10	13/64
12	7/32
16	15/64
20	1/4
24	1/4
32	9/32
*The figures vary upon change of wall thickness for a given size. Do not use these dimensions as an inspection standard, but rather as an approximation of proper tube projection.	

Proof Pressure Testing

Tube assemblies that are fabricated according to the instructions in *Aviation Hose and Tube Manual*, NAVAIR 01-1A-20, should be proof pressure tested to twice the operating pressure of the system in which they are to be installed, provided the operating pressure is greater than 50 psi. Tubing, installed in systems having an operating pressure of less than 50 psi must be proof pressure tested to a minimum of 100 psi. Vent tubes or drain tubes do not require proof pressure testing.

The fluid medium for proof pressure testing of all tube assemblies except oxygen systems should be a liquid medium such as hydraulic fluid, water, or oil.

Table 10-14.—Minimum Inside Diameter of Tubing

TUBE OUTSIDE DIAMETER	6061 ALUMINUM		1/8 HARD STAINLESS		ANNEALED STAINLESS	
	WALL	MIN ID	WALL	MIN ID	WALL	MIN ID
1/8	0.020	0.060	0.016	0.070	0.020	0.060
3/16	0.028	0.095	0.018	0.110	0.020	0.115
1/4	0.035	0.150	0.020	0.165	0.028	0.155
5/16	0.049	0.180	0.022	0.225	0.035	0.225
3/8	0.049	0.240	0.025	0.290	0.049	0.270
1/2	0.065	0.330	0.028	0.400	0.058	0.380
5/8	0.083	0.420	0.035	0.485	0.065	0.475
3/4	0.095	0.530	0.042	0.610	0.083	0.590
1	0.065	0.830	0.065	0.840	0.083	0.800
All measurements are in inches.						

Oxygen tubing should be tested using dry nitrogen and inspected for leaks while the tubing is submerged in water.

Cleaning Tubing and Tube Assemblies

All tubing and tube assemblies must be cleaned after fabrication to prevent contamination of the system in which they will be installed. Dry-cleaning solvent MIL-PRF-680, Type II, is the preferred cleaner.

Oxygen system tube assemblies require special precautions for cleaning. After fabrication, and testing, clean oxygen tube assemblies in accordance with MIL-STD-1330D. If a vapor degreaser is not used, tube assemblies must remain in the vapor degreaser until the

temperature specified in the manufacturing instructions is reached. Tube assemblies must be blown clean and dried with a stream of clean, dry, water-pumped air.

CAUTION

Oil-pumped air is not a suitable substitute for water-pumped air because it causes oil to be deposited in the tube assemblies. Oxygen reacts violently with oil and may cause equipment damage and injury to personnel. Oxygen (BB-O-925) or clean, dry, water-pumped nitrogen (BB-N-411) must be used in place of water-pumped air.

Protective Paint Finishes

Tube assemblies that require paint as a protective finish are described in table 10-15. Titanium or stainless steel tubing does not require primer or paint except in areas of dissimilar metals. Primer or paint on stainless steel tubing currently installed on naval aircraft need not be removed. The basic reason for this is that cracked or damaged paint systems establish a differential oxygen concentration cell, which may result in tubing corrosion damage.

Do not paint interior surfaces of airspeed indicator tubing, oxygen, or other plumbing lines. Tube assemblies located inside of an aircraft are interior tube assemblies. Tube assemblies located outside of an aircraft are exterior tube assemblies. Interior tube assemblies require a protective finish of two coats of zinc chromate, using application techniques as specified in *Aircraft Weapons System Cleaning and*

Corrosion Control, NA 01-1A-509. Protective finishes for exterior tube assemblies should be the same as for exterior aircraft surfaces specified in NA 01-1A-509.

Identification

Fabricated tube assemblies should be identified before installation or storage. All information from the identification tag of the removed tube assembly should be transferred to the tag on replacement tube assembly. Identify the tube assemblies by ink stamping or stenciling the part number, manufacturer's code, and other required data on tube assemblies. Apply a protective coat of clear varnish over the markings. To aid in the rapid identification of the various tubing systems and operating pressure, each fluid line in the aircraft is identified by bands of paint or strips of tape around the line near each fitting. These identifying media are applied at least once in each compartment. Various other information is also applied to the lines.

Table 10-15.—Prime and Paint for Tube Assemblies

CATEGORY	DESCRIPTION	*PRIME	PAINT
I	Single tube with separate connectors at each end.	Prime after forming, but before fabrication.	<p>Tube assemblies in categories I, II, and III shall be painted after fabrication and before installation, except for assemblies in category III, which have been partially primed.</p> <p>Partially primed tube assemblies in category III shall have additional primer applied as required followed by coating of all nonsealed-nonseparable joints with MIL-S-8802 before application of paint.</p>
II	Tube assemblies consisting of individual tubes permanently joined by nonseparable fittings such as those assembled by brazing, welding, and swaging and having separable connectors at each free end.	Prime after forming, follow by coating joints with MIL-S-8802 before fabrication.	
III	Single or multiple tube assemblies as in I and II, having one or more free ends which must be subsequently joined permanently to another tube assembly by brazing, welding, and swaging during installation.	<p>Prime after forming, follow by coating joints with MIL-S-8802 before fabrication.</p> <div style="border: 1px solid black; padding: 5px; text-align: center; margin: 10px 0;">CAUTION</div> <p>If primer is not compatible to permanent joining process, prime tubing a suitable distance away from affected end.</p>	
IV	Other tube assemblies not described in I, II, or III.	The cognizant rework facility shall specify the required protective finishes.	
<p>*Tubing assemblies in categories I, II, and III in which sleeves or ferrules are used in the separable connections and sleeves or ferrules are fixed in position by deforming one or more numbers, prime up to but not beyond initial point of contact. Tubing for use with flared systems shall be primed to the end of the tube.</p>			

Identification tapes are applied to all lines less than 4 inches in diameter except cold lines, hot lines, lines in oily environment, and lines in engine compartments where there is a possibility of the tape being drawn into the engine intake. In these cases, and all others where tapes should not be used, painted identification is applied to the lines.

Identification tape codes indicate the function, contents, hazards, direction of flow, and pressure in the fluid line. These tapes are applied in accordance with MIL-STD-1247C. This military standard was issued to standardize fluid line identification throughout the Department of Defense. Figure 10-41 shows the method of applying these tapes as specified by this standard.

The function of a line is identified by use of a tape, approximately 1 inch wide, upon which word(s), color(s), and geometric symbols are printed. Functional identification markings, as provided in MIL-STD-1247C, are the subject of international standardization agreements. Three-fourths of the total width on the left side of the tape has a code color or colors that indicate one function only per color or colors. The function of the line is printed in English across the colored portion of the tape. Even a non-English-speaking person can troubleshoot or maintain the aircraft if he/she knows the code but cannot read English. The right-hand one-fourth of the functional identification tape contains a geometric design rather than the color(s) or word(s). Figure 10-42 is a listing, in tabular form, of functions and their associated identification media as used on the tapes. Figure 10-43 shows the different tapes used in identifying tubing.

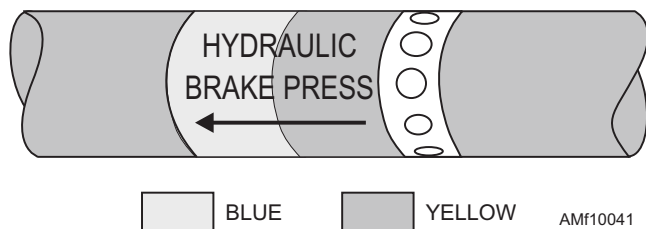

Figure 10-41.—Fluid line identification application.

The identification of hazards tape shows the hazard associated with the contents of the line. Tapes used to show hazards are approximately 1/2 inch wide, with the abbreviation of the hazard contained in the line printed across the tape. There are four general classes of hazards found in connection with fluid lines.

- **Flammable material (FLAM).** The hazard marking FLAM is used to identify all materials known ordinarily as flammables or combustibles.
- **Toxic and poisonous materials (TOXIC).** A line identified by the word TOXIC contains materials that are extremely hazardous to life or health.
- **Anesthetics and harmful materials (AAHM).** All materials productive of anesthetic vapors and all liquid chemicals and compounds hazardous to life and property, but not normally productive of dangerous quantities of fumes or vapors, are in this category.
- **Physically dangerous materials (PHDAN).** A line that carries material that is not dangerous within itself, but that is asphyxiating in confined areas or is generally handled in a dangerous physical state of pressure or temperature, is identified by the marking PHDAN.

FUNCTION	COLOR	SYMBOL
FUEL	RED	◆
ROCKET OXIDIZER	GREEN, GRAY	☾
ROCKET FUEL	RED, GRAY	◆☾
WATER INJECTION	RED, GRAY, RED	∇
LUBRICATION	YELLOW	⋮
HYDRAULIC	BLUE, YELLOW	●
SOLVENT	BLUE, BROWN	≡
PNEUMATIC	ORANGE, BLUE	✕
INSTRUMENT AIR	ORANGE, GRAY	∞
COOLANT	BLUE	~
BREATHING OXYGEN	GREEN	■
AIR CONDITIONING	BROWN, GRAY	⋯
MONOPROPELLANT	YELLOW, ORANGE	⊥
FIRE PROTECTION	BROWN	◆
DE-ICING	GRAY	▲
ROCKET CATALYST	YELLOW, GREEN	
COMPRESSED GAS	ORANGE	↘
ELECTRICAL CONDUIT	BROWN, ORANGE	⚡
INERTING	ORANGE, GREEN	++

AMf10042

Figure 10-42.—Functional identification type data.

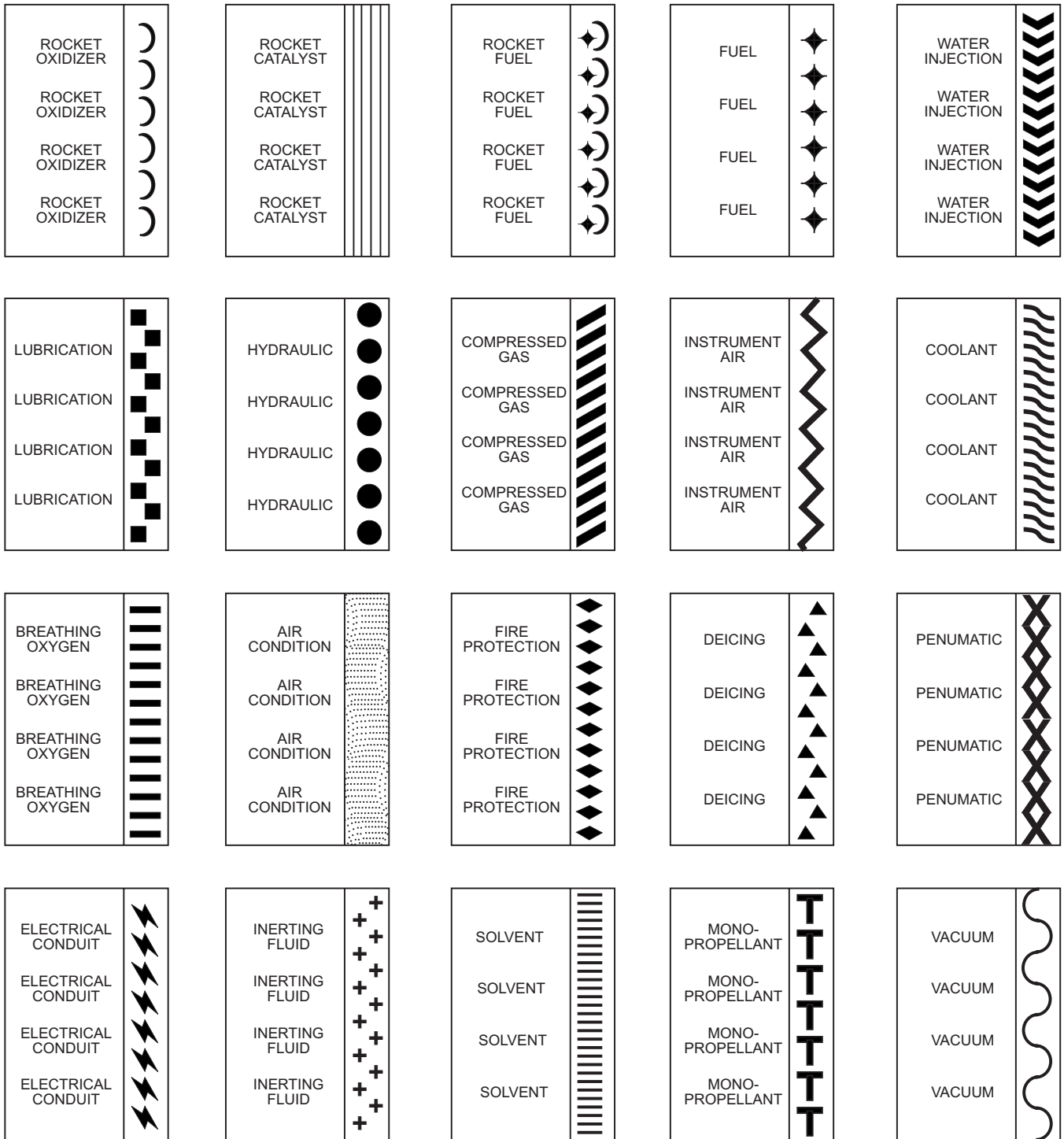

AMf10043a

Figure 10-43.—Color-coded functional identification tapes.

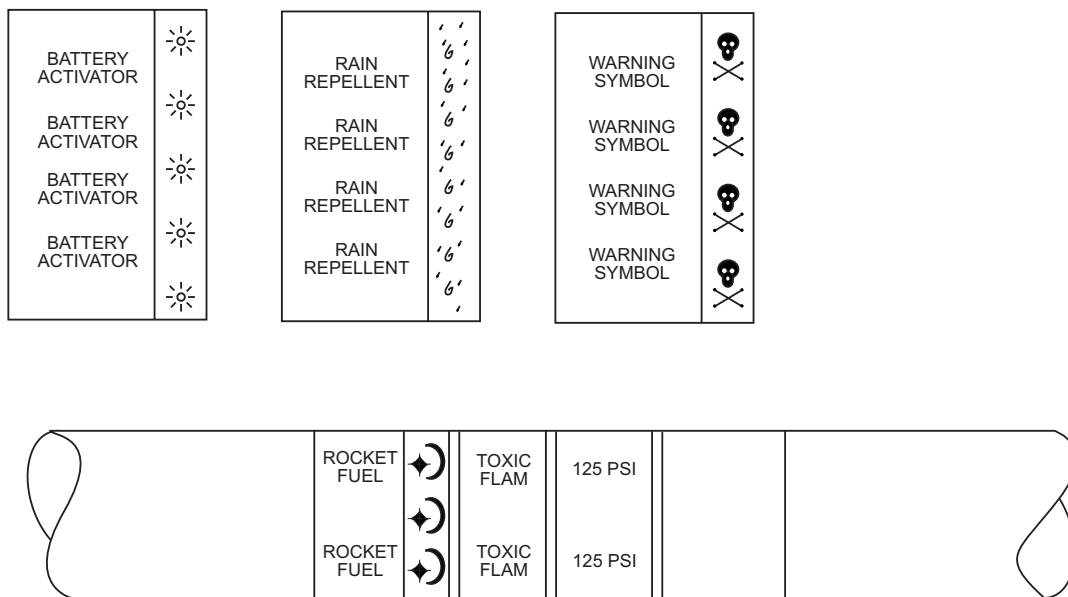

NOTES:

1. THE ABOVE COLOR CODES REPRESENT DESIGNATION FOR SYSTEMS ONLY. FOR CODING LINES WHICH DO NOT FALL INTO ONE OF THESE SYSTEMS, THE CONTENTS SHALL BE DESIGNATED BY BLACK LETTERING ON A WHITE TAPE.
2. SUBSIDIARY FUNCTIONS OR IDENTIFICATION OF LINE CONTENT MAY BE INDICATED BY THE USE OF ADDITIONAL WORDS OR ABBREVIATIONS WHICH SHALL BE CARRIED ON A SECOND TAPE ADJACENT TO THE FIRST OR ALTERNATIVELY, INTERPOSED BETWEEN THE WORDS DESCRIPTIVE OF THE MAIN FUNCTION.
3. WARNING SYMBOL TAPES, 3/8 INCH WIDE, SHALL BE APPLIED TO THOSE LINES WHOSE CONTENTS ARE CONSIDERED TO BE DANGEROUS TO MAINTENANCE PERSONNEL. WARNING TAPES ARE TO BE PLACED ADJACENT TO SYSTEM IDENTIFICATION TAPES.
4. ONE BAND SHALL BE LOCATED ON EACH TUBE SEGMENT, 24 INCHES OR SHORTER. ONE BAND SHALL BE LOCATED AT EACH END OF EACH TUBE SEGMENT LONGER THAN 24 INCHES. ADDITIONAL BANDS SHALL BE APPLIED WHEN THE TUBE SEGMENT PASSES THROUGH MORE THAN ONE COMPARTMENT OR BULKHEAD, AT LEAST ONE BAND SHALL BE VISIBLE IN EACH COMPARTMENT OR ON EACH SIDE OF THE BULKHEAD.
5. PRESSURE TRANSMITTER LINES SHALL BE IDENTIFIED BY THE SAME COLORS AS THE LINES FROM WHICH THE PRESSURE IS BEING TRANSMITTED.
6. FILLER LINES, VENT LINES AND DRAIN LINES OF A SYSTEM SHALL BE IDENTIFIED BY THE SAME COLORS AS THE RELATED SYSTEM.

CAUTION

TAPE SHALL NOT BE USED ON FLUID LINES IN THE ENGINE COMPARTMENT WHERE THERE IS A POSSIBILITY OF THE TAPE BEING DRAWN INTO THE ENGINE INTAKE. FOR SUCH LOCATIONS, SUITABLE PAINTS, CONFORMING TO THIS COLOR CODE, AND WHICH HAVE NO HARMFUL EFFECT ON THE MATERIAL USED FOR THE LINES, SHALL BE USED FOR IDENTIFICATION PURPOSES. IN THESE CASES, THE GEOMETRICAL SYMBOLS MAY BE OMITTED.

AMf10043b

Figure 10-43.—Color-coded functional identification tapes—Continued.

Table 10-16 lists some of the fluids with which you may be required to work and the hazards associated with each one.

Table 10-16.—Hazards Associated with Various Fluids

Contents	Hazard
Air (under pressure)	PHDAN
Alcohol	FLAM
Carbon dioxide	PHDAN
Freon	PHDAN
Gaseous oxygen	PHDAN
Liquid nitrogen	PHDAN
Liquid oxygen	PHDAN
LPG (liquid petroleum gas)	FLAM
Nitrogen gas	PHDAN
Oils and greases	FLAM
JP-5	FLAM
Trichloroethylene	AAHM

For convenience in distinguishing one hydraulic line from another, each line is designated as to its function within the system. In general, the various hydraulic lines are designated as follows:

Supply lines. Lines that carry fluid from the reservoir to the pumps are called supply (or suction) lines.

Pressure lines. Lines that carry only pressure are called pressure lines. Pressure lines lead from the pumps to a pressure manifold, and from the pressure manifold to the various selector valves, or they may run directly from the pump to the selector valve.

Operating lines. Lines that alternately carry pressure to an actuating unit and return fluid from the actuating unit are called operating lines, or working lines. Each operating line is identified in the aircraft according to its specific function; for example, LANDING GEAR UP, LANDING GEAR DOWN, FLAPS UP, FLAPS DOWN.

Return lines. Lines that are used to return fluid from any portion of the system to the reservoir are called return lines.

Vent lines. Lines that carry excess fluid overboard or into another receptacle are called vent lines.

Storage

Fabricated tubing and tube assemblies requiring storage for any length of time should be provided with protective closures at each end.

Do not use pressure-sensitive tape as a substitute for protective closures. Oxygen tube assemblies require protection of the entire assembly in addition to protective closures at end fittings. The complete assembly should be stored and packaged in sealed plastic bags in accordance with *Aviation Crew Systems Manual Oxygen Equipment*, NA 13-1-6.4.

TUBING AND TUBE ASSEMBLIES MAINTENANCE PROCEDURES

Maintenance of tube assemblies at the organizational level is limited to inspection, removal, installation, repair and replacement. Inspections are performed during fabrication, installation, and on in-service equipment. During fabrication, inspect bulk tubing and fittings before and during fabrication of a tube assembly. Before replacing a defective tube assembly, find the cause of failure, and inspect the tube assembly before and after its installation. Inspect in-service tube assemblies at regular intervals in accordance with applicable maintenance directives. When you inspect the tube and tube assemblies for damage, look for chafing, galling, or fretting, which may reduce the ability of tubing to withstand internal pressure and vibration. Replace tubing that shows visible penetration of the tube wall surface caused by chafing, galling, or fretting. Tubes that have damage (nicks, scratches, or dents) caused by careless handling of tools are acceptable if they meet the following requirements: Any dent that has a depth less than 20 percent of the tubing diameter is acceptable unless the dent is on the heel of a short bend radius. A nick or scratch that has a depth of less than 15 percent of the wall thickness of aluminum, aluminum alloy, or steel tubing should be reworked by burnishing with hand tools before it is acceptable. Any aluminum, aluminum alloy, or steel tubing carrying pressures greater than 100 psi with nicks or scratches greater than 15 percent of wall thickness should be replaced.

Inspect each fitting (fig. 10-44) before it is installed. Visually or flow check to make sure that fitting passage or passages are free from obstructions.

Installation

Installation of tube assemblies involves a pre-installation check before tube assemblies can be

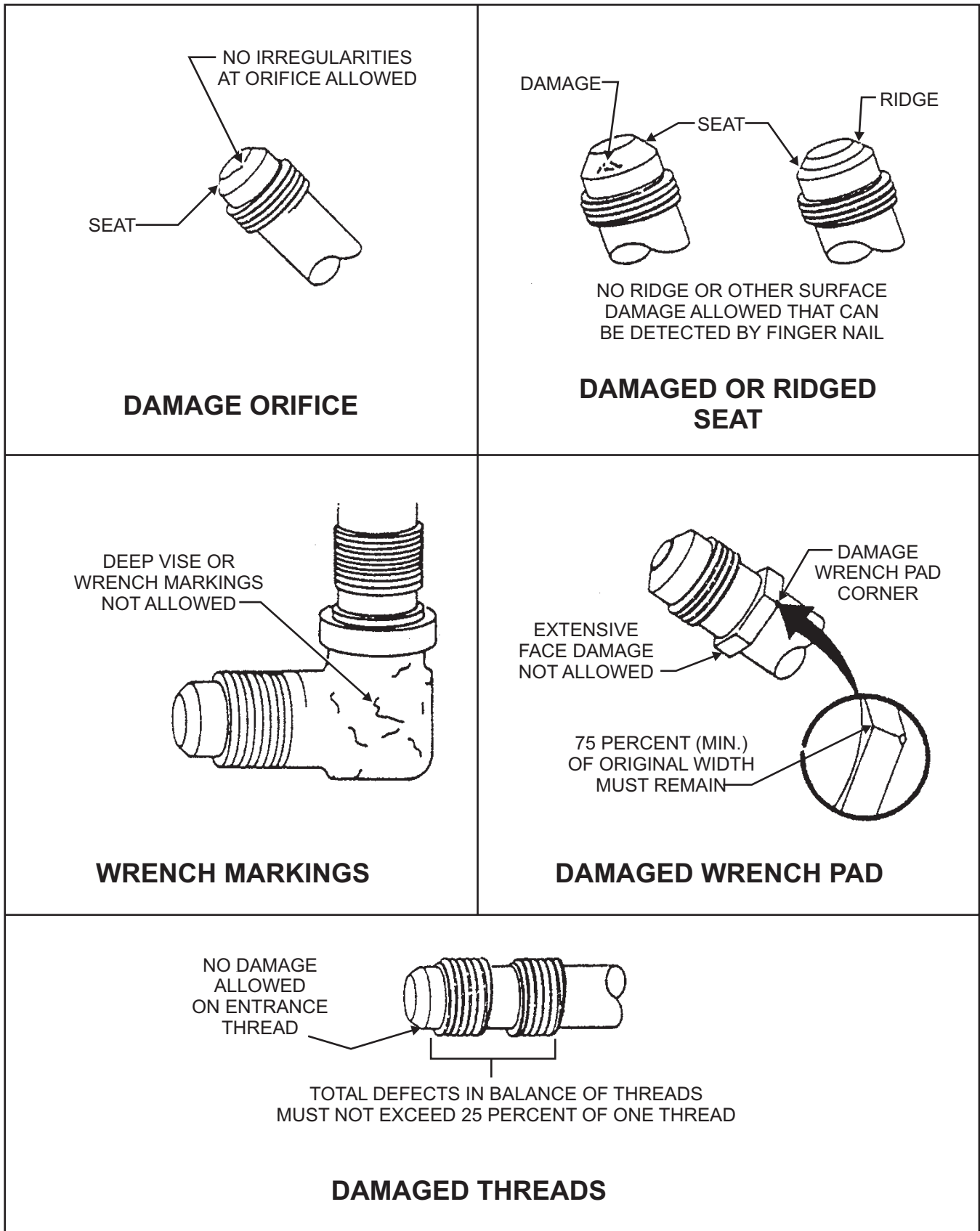

AMf10044

Figure 10-44.—Damaged fittings.

installed. Before you install tube assemblies, check to make sure there are no dents, nicks, and scratches; that the assembly contains the correct nuts and sleeves; that there is a proper fit, where fitting is flared; that a proof pressure test is performed on each assembly; and that the assemblies are clean.

To install tube assemblies, hand screw the nuts onto mating connectors. Align the tube assembly in place so that it will not be necessary to pull it into place with the nut. Tubing that runs through cutouts should be installed to avoid scarring when the tubing is worked through a hole. If the tube assembly is long, tape the edge of cutouts before installing the assembly. Torque the nuts. Apply a protective coating to the remaining nonsealed joints after tubing is installed. For disconnected nonsealed joints, apply MIL-S-8802, followed by appropriate paint system, if required. For connected nonsealed joints, apply the first coat of MIL-C-16173, grade 4; 1 hour after applying the first coat, apply the second coat of MIL-C-16173, grade 4. Correct and incorrect methods of installing flared tube assemblies are shown in figure 10-45.

Leakage of a flared tube assembly is usually caused by the following:

- Flare distorted into the nut threads.
- Sleeve cracked.
- Flare out of round.
- Flare cracked or split.
- Inside of flare rough or scratched.
- Connector mating surface rough or scratched.
- Connector threads or nuts are dirty, damaged, or broken.

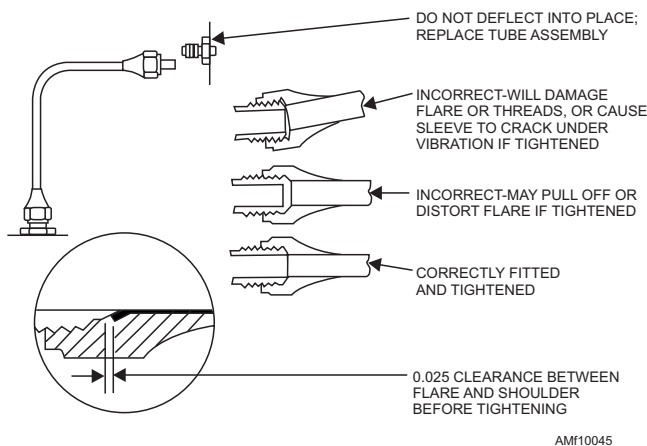

Figure 10-45.—Correct and incorrect methods of installing flared fittings.

If an aluminum alloy flared tube assembly leaks after it has been tightened to the required torque, disassemble it for repair or replacement. If a steel flared tube assembly leaks, it may be tightened one-sixteenth turn beyond the noted torque. If the assembly continues to leak, it should be disassembled for repair or replacement. Do not tighten a nut when there is pressure in the line. Do not overtighten a leaking aluminum alloy assembly. Overtightening may severely damage or cut off tubing flare, or damage sleeve or nut.

When you install flareless tube assemblies, proceed as follows: Make sure no nicks or scratches are evident and the sleeve is preset. Tighten the nut by hand until resistance to turning develops. If it is impossible to use fingers to run nut down, use a wrench. Look out for the first signs of bottoming. Do not use pliers to tighten tube connectors.

Final tightening should begin at the point where the nut begins to bottom. Use a torque wrench if fitting is accessible and torque fitting. If a connection is not accessible for torque wrench, use a wrench to turn nut one-sixth turn while holding the connector with another wrench to prevent the connector from turning. A one-sixth turn equals the travel of one flat on a hex nut. Tighten nut an additional one-sixth turn if the connector leaks. Do not tighten fitting nut more than one-third of a turn (two flats on nuts). Loosen and completely disconnect the nut if the leak continues. Inspect fitting components for scores, cracks, foreign material, or damage from previous overtightening. Reassemble fitting. Fingertighten nut and repeat wrench tightening. It is important to tighten tube fitting nuts properly. A fitting wrench or an open-end wrench should be used when tightening connections.

All hydraulic tubing should be supported from rigid structures by cushioned steel clamps MIL-C-85052 or multiple tube block clamps. See figure 10-46. Hydraulic tubing support clamps should be installed and maintained in the positions described in the MIM or applicable technical directives.

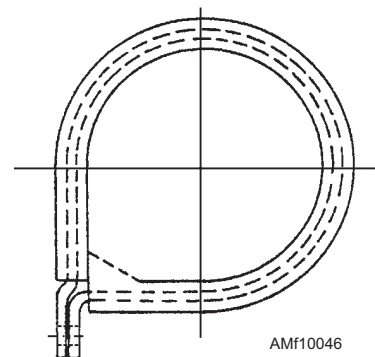

Figure 10-46.—Cushioned steel clamps MIL-C-85052.

Table 10-17.—Maximum Distance Between Supports for Aluminum Tubing

TUBING OUTSIDE DIAMETER (INCHES)	DISTANCE BETWEEN SUPPORTS IN INCHES	
	ALUMINUM ALLOY	STEEL
1/8	9-1/2	11-1/2
3/16	12	14
1/4	13-1/2	16
5/16	15	18
3/8	16-1/2	20
1/2	19	23
5/8	22	25-1/2
3/4	24	27-1/2
1	26-1/2	30-1/2
1-1/4	28-1/2	31-1/2
1-1/2	29-1/2	32-1/2

Unless otherwise specified, where tubing is supported to structure or other rigid members, a minimum clearance of 1/16 inch or where related motion of adjoining components exists, a minimum clearance of 1/4 inch is to be maintained. Table 10-17 shows the maximum allowable distance between supports. Flexible grommets or hose should be used at points where the tubing passes through bulkheads.

Repair

Tube repair is divided into two categories—temporary and permanent. Temporary

repairs are made with splice sections fabricated with flared ends or preset MS sleeves. The splice sections are to be replaced by a permanent repair or new tubing assembly at the next rework cycle. Temporary or emergency repairs should be limited to cases that are due to unavailability of equipment, material, or unusual circumstances.

Cut and remove the damaged section of tubing. Remove the rough edges of the remaining tube ends. Clean the tubing ends with a lint-free wiping cloth. Position the AN818 nuts and AN819 sleeves on the tubing ends (fig. 10-47). Flare the tubing. Install

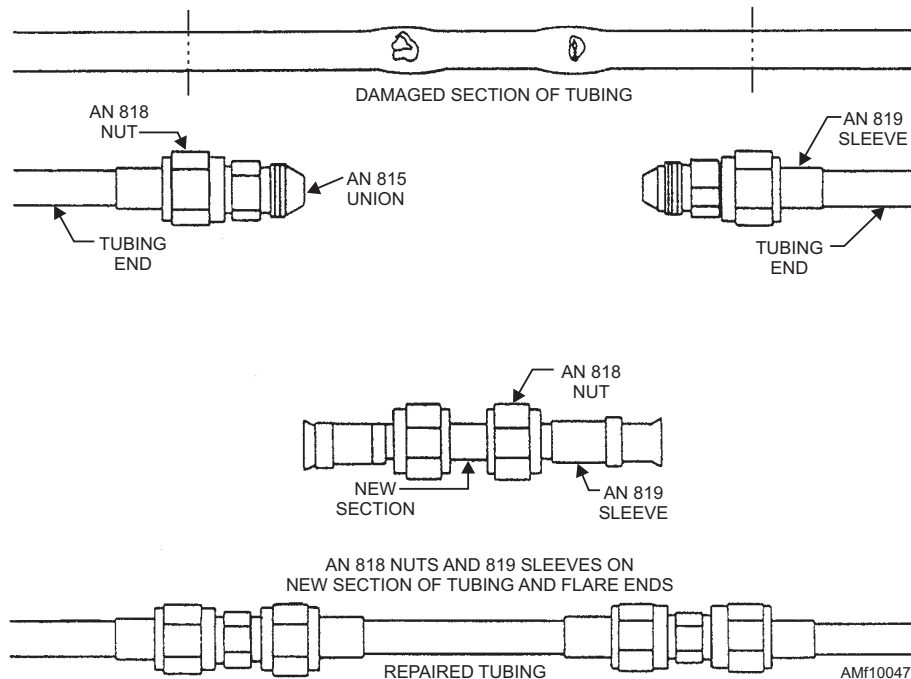

Figure 10-47.—Temporary tubing repair.

AN815 unions. Position the AN818 nuts and AN819 sleeves on the new section. A new section is not required when the length of the union is longer than the damaged section. Install the new section of tubing and tighten the AN818 nuts. Permanent repairs include removal of minor damage on tubing and fittings and the replacement of line sections or fittings by Permaswage or Dynatube swaging equipment, or by induction brazing.

NOTE: Induction brazing is limited to depot-level repair. Tube assemblies used for engine-related hydraulic, fuel, oil, vent or drain lines usually have brazed or welded end fittings. These engine-related tube assemblies are normally fabricated from corrosion-resistant steel.

Some minor surface damages to tubing are acceptable, as described in inspection of tubing damage. A nick that is not deeper than 15 percent of the wall thickness of aluminum, aluminum alloy, or corrosion-resistant steel is acceptable after being reworked by burnishing with hand tools. Minor damage to fittings is defined as damage not to exceed repairable limits, as shown in figure 10-48.

Fittings that exceed repairable limits should be replaced. To repair damaged fittings, proceed as follows: To repair damaged orifices, remove any restriction in the orifice and handstone it to blend rough edges or burrs, as shown in view A of figure 10-48. To repair damaged or ridged seats, resurface circumferential ridges with annular tool, as shown in

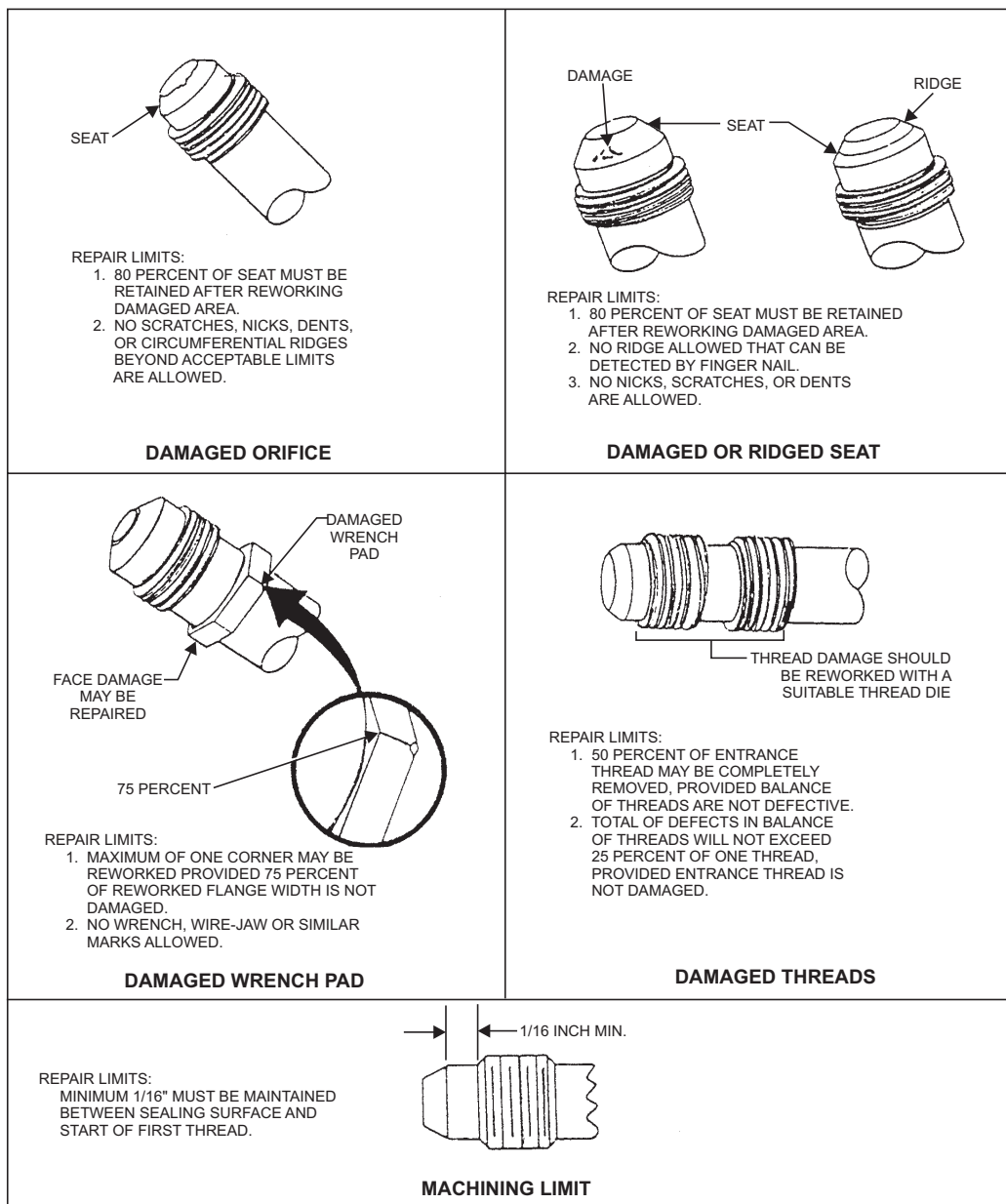

AMf10048

Figure 10-48.—Reworking damaged fittings.

view B of figure 10-48. Tool marks other than those of annular tools (one ten-thousandth of an inch RMS) are permitted on sealing surface. Damaged wrench pads are repaired by removing minor scratches with a fine file, leaving no file marks, as shown in view C of figure 10-48. Resurface the 37-degree sealing surface. A minimum distance of 1/16 inch (.063) should be maintained between the 37-degree sealing surface and the start of the first thread (view E of fig. 10-48).

All reworked fittings should be inspected and treated against corrosion. Reworked aluminum alloy fittings should be anodized; however, uniform color of reworked fittings after anodizing is not necessary.

PERMASWAGE FITTING REPAIR.—The basic element of the Permaswage repair technique is the Permaswage fitting, which is mechanically swaged onto the tube by a hydraulically operated tool. Permaswage fittings are designed for use by all levels of maintenance, and are available in various configurations. Tube assembly repair using Permaswage fittings and techniques is considered permanent repair.

Four basic types of tube assembly failures lend themselves to permanent repair using Permaswage fittings and techniques. Each type of tube assembly failure and its recommended repair is described in table 10-18.

Table 10-18.—Tube Assembly Failures and Recommended Repair Methods

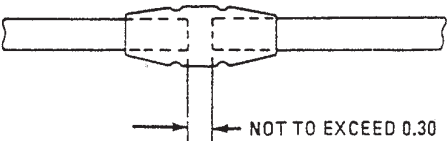
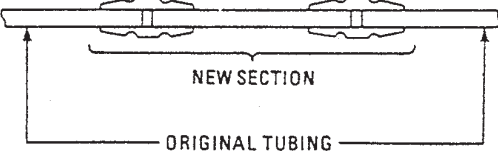
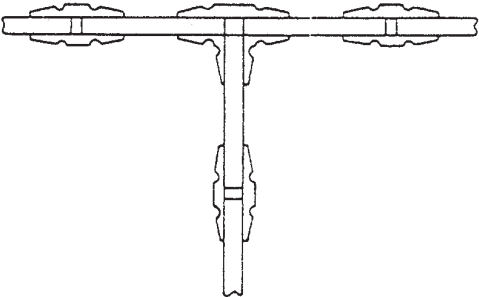
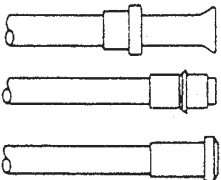
TYPE OF FAILURE	REPAIR METHOD
<p>1. Pin hole leak or circumferential crack in tubing.</p> 	<p>1.a. Make 1 or 2 cuts as necessary, to remove damaged section. If 2 cuts are required, the distance between them shall not exceed 0.30 inch. If distance is more than 0.30 inch, go to repair method 2.</p> <p>b. Swage 1 tube to tube union in tube section under repair.</p>
<p>2. Longitudinal crack in tubing (crack length in excess of 0.30 inch).</p> 	<p>2.a. Make 2 cuts to enable removal of damaged section.</p> <p>b. Remove damaged section and duplicate.</p> <p>c. Swage replacement section into tubing under repair using 2 tube to tube unions.</p>
<p>3. Leaking tee or elbow (permanent tube connection type).</p> 	<p>3.a. Cut out defective tee or elbow.</p> <p>b. Duplicate tubing sections for each branch.</p> <p>c. Swage splice sections to tee or elbow.</p> <p>d. Connect each splice section to tubing under repair using a tube to tube union.</p>
<p>4. Leaking flared, flareless or lipseal end fittings.</p> 	<p>4.a. Cut tubing to remove defective fitting.</p> <p>b. Swage appropriate end fitting to tube end.</p> <p>c. Connect new end fitting to mating connection, torquing nut as required.</p>

AM110018

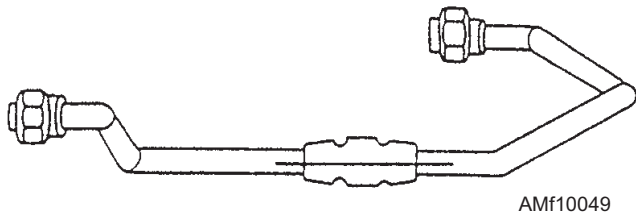

Figure 10-49.—Marking tube.

Before you cut a tube, use a marking pen and a ruler to draw a line parallel to the tube run across the section to be cut (fig. 10-49). Cut the tubing. If a tube end is to be replaced, make sure the line is placed in the same location on the new tube as on the tube section that has been removed. Draw a line across the fitting. Install the tube run and locate the fitting. Fingertighten any end fittings. One end of the fitting may be swaged on the bench if possible. Place the swaging tool on the first end being swaged, and line up the line on the tube end being swaged with the line on fitting. Repeat the procedure with the other ends to be swaged. Torque the fittings.

In addition to the four types of repairs described in table 10-18, flared, flareless, and lipseal end fittings may often be repaired by replacing defective end fittings with Permaswage fittings.

Permaswage tube repair equipment consists of two series, D10000 and D12200. Each series has three separate tool kits and a hydraulic power supply. Installation of fittings by use of either series depends upon the size of fittings, pressure rating, and access to damaged area.

The series D12200 and series D10000 tool kits differ only in the range of tube sizes that each kit can swage. Figure 10-50 illustrates a typical series D10000 tool kit. Series D10000 swaging tools make permanent tubing joints by swaging Permaswage fittings onto

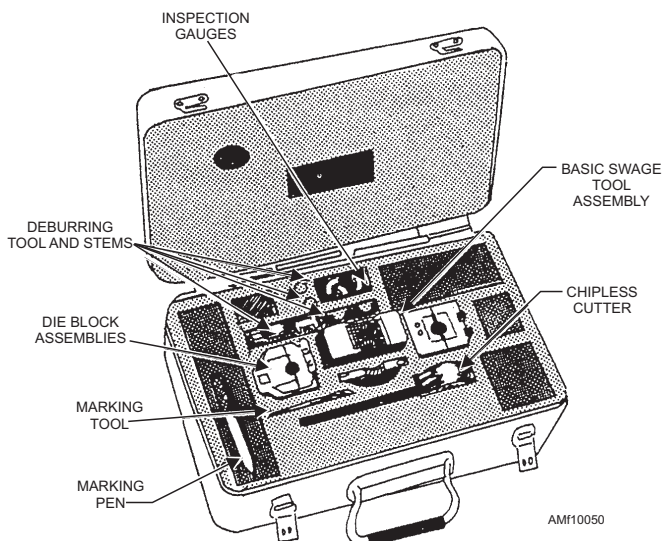

Figure 10-50.—Permaswage Tool Kit D10031-812S.

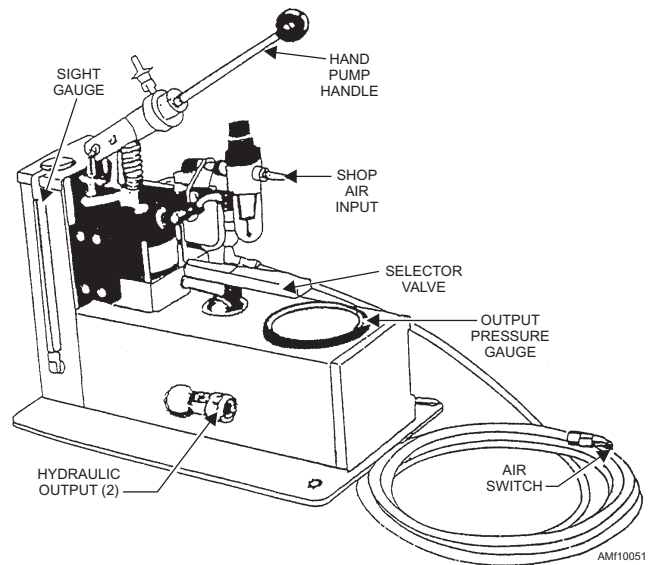

Figure 10-51.—D10004 Permaswage hydraulic power supply.

compatible tubing. The fittings may be unions, tees, crosses, separable fittings, reducer fittings, and other special fittings.

Hydraulic pressure supplied by a portable hydraulic power supply (fig. 10-51) causes die segments contained within the swaging tool (fig. 10-52) to swage. The basic swage tool assembly contains the actuating piston and a locking latch, which ensures upper die block retention during the swage cycle. The swaging tool is designed to operate over a range of tubing sizes and types of fittings by changing die block assemblies and/or fitting locators. The die block assemblies are supplied in sets, consisting of upper and lower die blocks, dies, and locators. The lower die block is retained on the basic swage tool assembly to make sure of automatic retraction and consistent repeatability. The upper die block assembly is removable for easy loading.

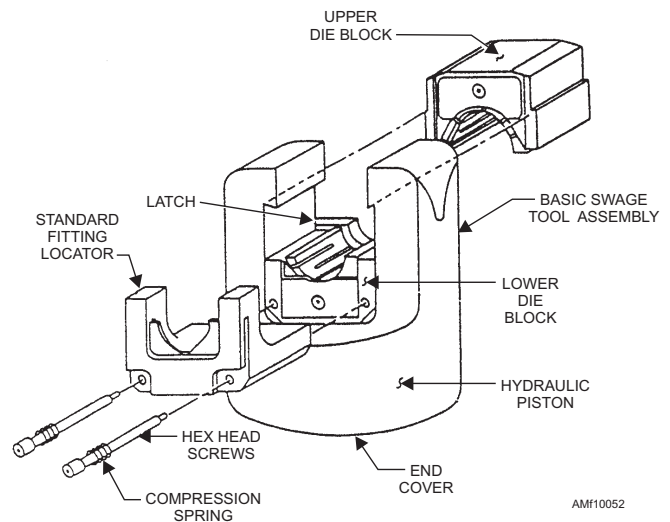

Figure 10-52.—Basic swage tool assembly.

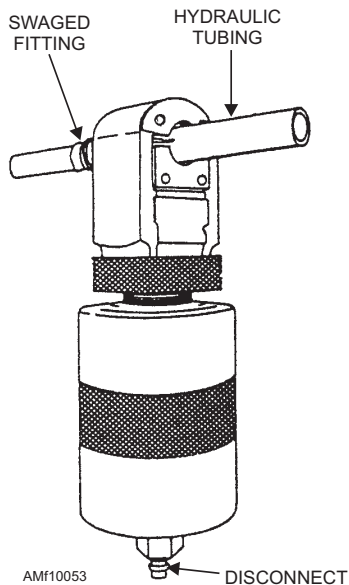

Figure 10-53.—Series D12200 kit swage tool operation.

As a supplement to the series D10000 tool kits, the series D12200 tool kits (fig. 10-53) may be used. The newer type of tooling is smaller in size and is designed to repair tubing on board aircraft.

The portable hydraulic power supply D10004 (fig. 10-51) generates 5,500 psi to operate the swaging tool. Hydraulic fluid is fed to the tool through a 1/4-inch quick-disconnect, high-pressure hose. As a precaution against premature tool fatigue, the swaging pressure is kept from exceeding 5,500 psi by the pressure relief valve. The D10004 hydraulic power supply can be operated either manually by using a hand pump or automatically by air-to-hydraulic fluid intensification from a 80 ± 20 psi pressure shop air source.

DYNATUBE FITTING REPAIR.—Dynatube fittings consist of a threaded male connector, a female shoulder with a machined beam, and a nut (fig. 10-54). Compared to the five components in a standard MS

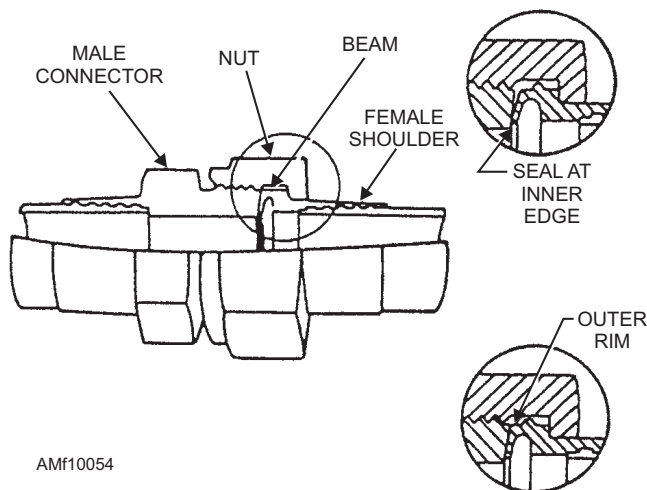

Figure 10-54.—Dynatube fitting.

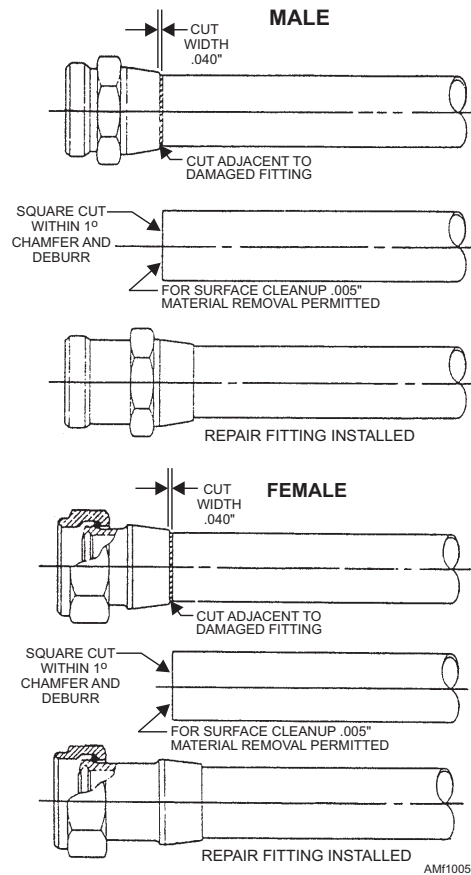

Figure 10-55.—Male and female repair fitting installation.

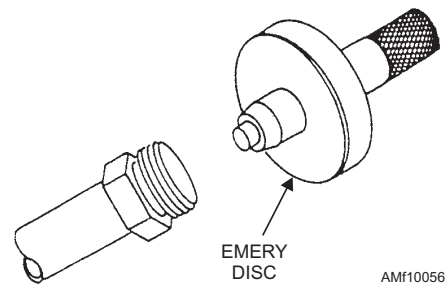

Figure 10-56.—Dynatube fitting resurfacing tool.

fitting, the three components in a Dynatube fitting are smaller, lighter, and have fewer potential leak paths. Dynatube fittings can be connected to rigid tubing by welding, but internal mechanical swaging with Resistoflex hand tools is the authorized method for Navy personnel.

The repair methods using Dynatube fittings are illustrated in figures 10-55 through 10-57.

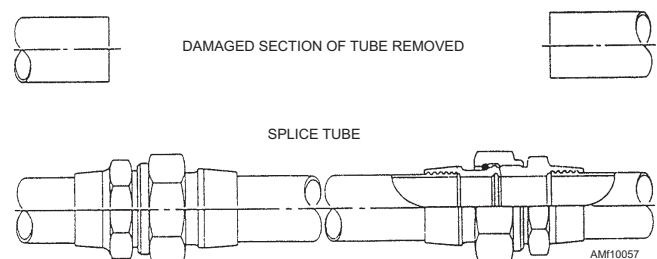
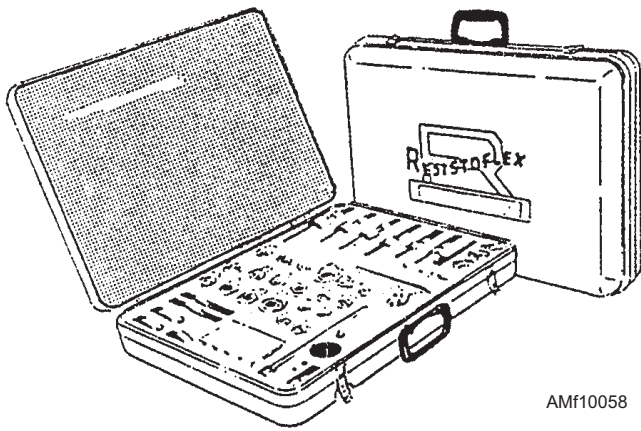

Figure 10-57.—Splice assembly repair.



AMf10058

Figure 10-58.—Field installation and repair tool kit (Resistoflex).

One method of repairing damaged Dynatube fittings is to use longer length Dynatube fittings. These can be installed in place of damaged fittings on the same tube assembly, as shown in figure 10-55. Dynatube male fittings with minor surface damage such as scratches can be repaired using the Dynatube fitting resurfacing tool, shown in figure 10-56.

Do not attempt to repair a damaged female Dynatube fitting. Damaged straight tubing can be repaired by cutting out the damaged section and installing a splice assembly in its place, as shown in figure 10-57.

Resistoflex hand tools are housed in a single carrying case (fig. 10-58). These tools are designed for in-place repairs. Figure 10-59 shows tools assembled for swaging process. Some of the tools used to swage fitting are shown in figure 10-60.

Tube expanders are precision swaging tools for expanding hydraulic tubing into serrations of Dynatube fitting sockets. Tube expanders are set to expand tubing to a specific diameter, and must be used only with the

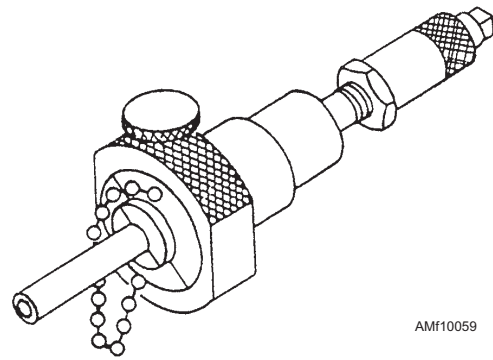

AMf10059

Figure 10-59.—Dynatube swaging process.

tube and wall thickness stated on the tool identification band.

Holding fixture dies support and position Dynatube fittings during swaging. Holding fixture dies have a nest that conforms to the shape and size of the fitting to be used. A male and female set of dies is provided for each basic tube diameter size that corresponds with male or female Dynatube fittings. Holding fixture collars are used to clamp holding fixture dies shut during swaging. The resurfacing tool assembly uses replaceable energy discs in progressively finer grades to remove scratches from the sealing surface of male fittings.

- Q10-13. *How are rigid tubing assemblies sized?*
- Q10-14. *What type of tubing is used in a high-pressure hydraulic system that has 3000 psi or above?*
- Q10-15. *What type of tubing is used for general-purpose lines?*
- Q10-16. *What color is a carbon steel tube fitting?*
- Q10-17. *What manual must you refer to when fabricating a tube assembly?*
- Q10-18. *What is the primary objective when cutting a piece of tubing?*

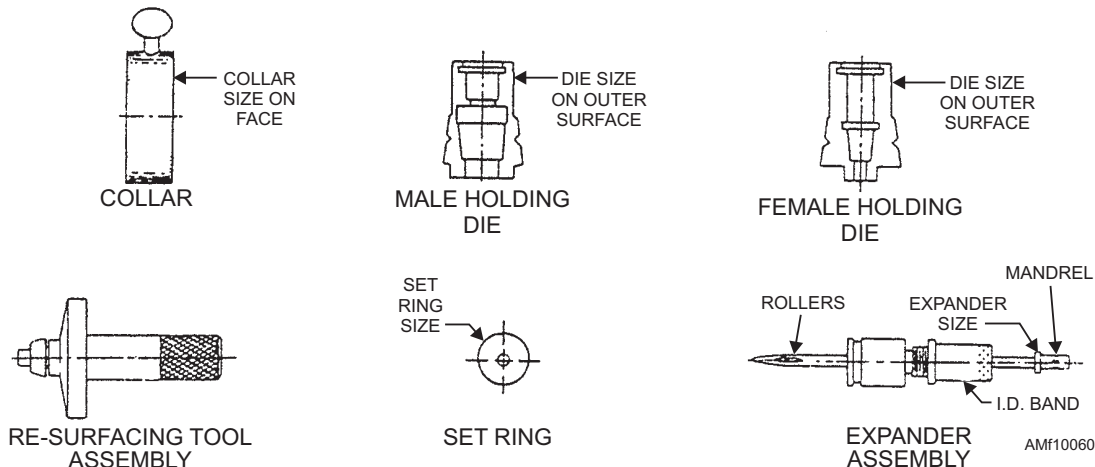

AMf10060

Figure 10-60.—Swaging and repair tool kit.

Q10-19. What must be done to a tube immediately after it has been cut?

Q10-20. What is the primary objective when bending a piece of tubing?

Q10-21. What are the two types of tube joints used on naval aircraft?

Q10-22. What is used to lubricate the threads of a hydraulic line prior to installation?

Q10-23. What is the preferred cleaner for cleaning a tube assembly?

Q10-24. The depth of a dent in a tube assembly must not exceed what percentage of the tubing diameter?

Q10-25. How many different types of repairs can be made on a tube assembly?

CHAPTER 11

BASIC ACTUATING SYSTEMS

INTRODUCTION

The actuating systems consist of the hydraulic components used to direct and control the flow of pressurized fluid as well as the components used to perform the actual work. This chapter covers actuating units and most of the various actuating system components that are used in modern-day hydraulic systems.

ACTUATING UNITS

LEARNING OBJECTIVE: Identify various hydraulic actuating units.

An actuating unit may be defined as a unit that transforms hydraulic fluid pressure into mechanical force, which performs work (moving some mechanism). Two types of actuating units are used in naval aircraft—actuating cylinders and hydraulic motors.

TYPES OF ACTUATING CYLINDERS

Actuating cylinders are the most commonly used actuating units in aircraft hydraulic systems. The purpose of an actuating cylinder is to convert fluid under pressure into linear or mechanical motion. Actuating cylinders are generally installed in such a manner that the piston shaft (rod) end of the cylinder is attached to the mechanism to be actuated, with the other end attached to the aircraft structure.

There are two types of actuating cylinders—balanced or unbalanced. Balanced actuators have equal working areas, with a piston shaft extending from both sides of the piston head. This type of cylinder may be a single-acting actuator, which receives hydraulic pressure on only one side of the piston head for movement in one direction, and some other means of force for movement in the opposite direction. However, it may also be a double-acting type, which uses hydraulic pressure alternately on both sides of the piston head to move it in the selected direction.

The most common type of actuating cylinder used on naval aircraft is the unbalanced type, which may be

either single or double acting. Unlike the balanced actuator, it has a single piston shaft extending from the piston head, resulting in unequal working areas. Each actuator used may differ considerably in size and construction.

Single-Acting Actuating Cylinder

The single-acting, piston-type cylinder uses fluid pressure to apply force in only one direction. In some designs of this type, the force of gravity moves the piston in the opposite direction. However, most cylinders of this type apply force in both directions. Fluid pressure provides the force in one direction, and spring tension provides the force in the opposite direction. In some single-acting cylinders, compressed air or nitrogen is used instead of a spring for movement in the direction opposite that achieved with fluid pressure.

Figure 11-1 shows a single-acting, spring-loaded, piston-type actuating cylinder. In this cylinder the spring is located on the rod side of the piston. In some spring-loaded cylinders, the spring is located on the blank side, and the fluid port is located on the rod side of the cylinder.

A three-way directional control valve is normally used to control the operation of this type of cylinder. To extend the piston rod, fluid under pressure is directed through the port and into the cylinder. See figure 11-1. This pressure acts on the surface area of the blank side of the piston, and forces the piston to the right. This action, of course, extends the rod to the right, through the end of the cylinder. The actuated unit is moved in one direction. During this action, the

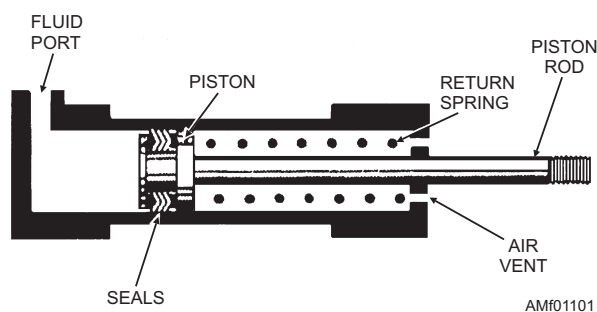

Figure 11-1.—Single-acting, spring-loaded, piston-type, actuating cylinder.

spring is compressed between the rod side of the piston and the end of the cylinder. Within limits of the cylinder, the length of the stroke depends upon the desired movement of the actuated unit.

To retract the piston rod, the directional control valve is moved to the opposite working position, which releases the pressure in the cylinder. The spring tension forces the piston to the left, retracting the piston rod and moving the actuated unit in the opposite direction. The fluid is free to flow from the cylinder through the port, and back through the control valve to return.

The end of the cylinder opposite the fluid port is vented to the atmosphere. This prevents air from being trapped in this area. Any trapped air would compress during the extension stroke, creating excess pressure on the rod side of the piston. This would cause sluggish movement of the piston, and could eventually cause a complete lock, preventing the fluid pressure from moving the piston. Seals prevent leakage between the cylinder wall and the piston. Hydraulic components use seals or gaskets to prevent leakage between static parts (nonmoving), such as a valve body and a hydraulic line fitting. Seals also prevent leakage between dynamic (moving) parts, such as the piston and cylinder wall. The most common seal is an O-ring. Some static seals and all dynamic seals require a backup ring or rings.

Double-Acting Actuating Cylinder

Most piston-type actuating cylinders are double-acting, which means that fluid under pressure can be applied to either side of the piston to provide movement and apply force in the corresponding direction. One design of the double-acting, piston-type, actuating cylinder is shown in view A of figure 11-2. This cylinder contains one piston and piston rod assembly. The stroke of the piston and piston rod assembly in either direction is produced by fluid pressure. The two fluid ports, one near each end of the cylinder, alternate as inlet and outlet, depending upon the direction of flow from the directional control valve.

This is referred to as an unbalanced actuating cylinder; that is, there is a difference in the effective working areas on the two sides of the piston. Refer to view A of figure 11-2. Assume that the cross-sectional area of the piston is 3 square inches and the cross-sectional area of the rod is 1 square inch. In a 2,000-psi system, pressure acting against the blank

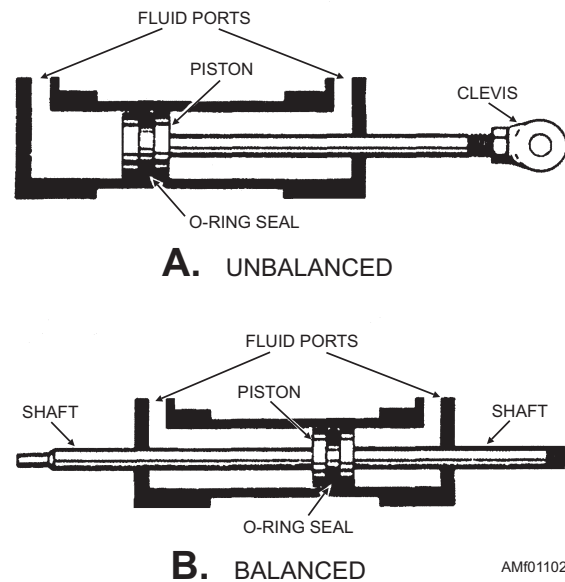

Figure 11-2.—Double-acting, piston-type, actuating cylinders.

side of the piston creates a force of 6,000 pounds (2,000 x 3). When the pressure is applied to the rod side of the piston, the 2,000-psi pressure acts on 2 square inches (the cross-sectional area of the piston less the cross-sectional area of the rod) and creates a force of 4,000 pounds (2,000 x 2). For this reason, this type of cylinder is normally installed in such a manner that the blank side of the piston carries the greater load; that is, the cylinder carries the greater load during the piston rod extension stroke.

A four-way directional control valve is normally used to control the operation of this type of cylinder. The valve can be positioned to direct fluid under pressure to either end of the cylinder, and to allow the displaced fluid to flow from the opposite end of the cylinder through the control valve to return/exhaust.

The piston of the cylinder shown in view A of figure 11-2 is equipped with an O-ring seal and backup rings to prevent internal leakage of fluid from one side of the piston to the other. Suitable seals and backup rings are also used between the hole in the end cap and the piston rod to prevent external leakage. In addition, some cylinders of this type have a felt wiper ring attached to the inside of the end cap and fitted around the piston rod to guard against the entrance of dirt and other foreign matter into the cylinder.

The actuating cylinder shown in view B of figure 11-2 is a double-acting-balanced type. The piston rod extends through the piston and out through both ends of the cylinder. One or both ends of the piston rod may be attached to a mechanism to be actuated. In either

case, the cylinder provides equal areas on each side of the piston so that the amount of fluid and force required to move the piston a certain distance in one direction is exactly the same as the amount required to move it an equal distance in the opposite direction.

Actuators are designed for a particular type of installation. For example, internal locking cylinders are used on some bomb bay door installations, while cushioned types are used where it is necessary to slow the extension or retraction of landing gears.

Mechanical-Lock Actuating Cylinder

In many installations it is necessary to lock an actuating cylinder in a specified position. This may be

for safety or operational requirements of the unit. The different designs of lock cylinders vary between manufacturers, but they are usually of the ball-lock or finger-lock type. At times, indicating devices are also incorporated along with the lock feature of the cylinders.

BALL-LOCK ACTUATOR.—The cylinder shown in figure 11-3 is a single-action, ball-lock actuating cylinder. Its purpose is to lock the down-lock mechanism of the landing gear. The ball-lock feature is in the lock position when the landing gear is extended.

The main parts of this cylinder are the body, end caps, piston shaft and head, ball-lock plunger, locking ball bearings, ball bearing race, spring guide, compressor spring, rod, and down-lock switch.

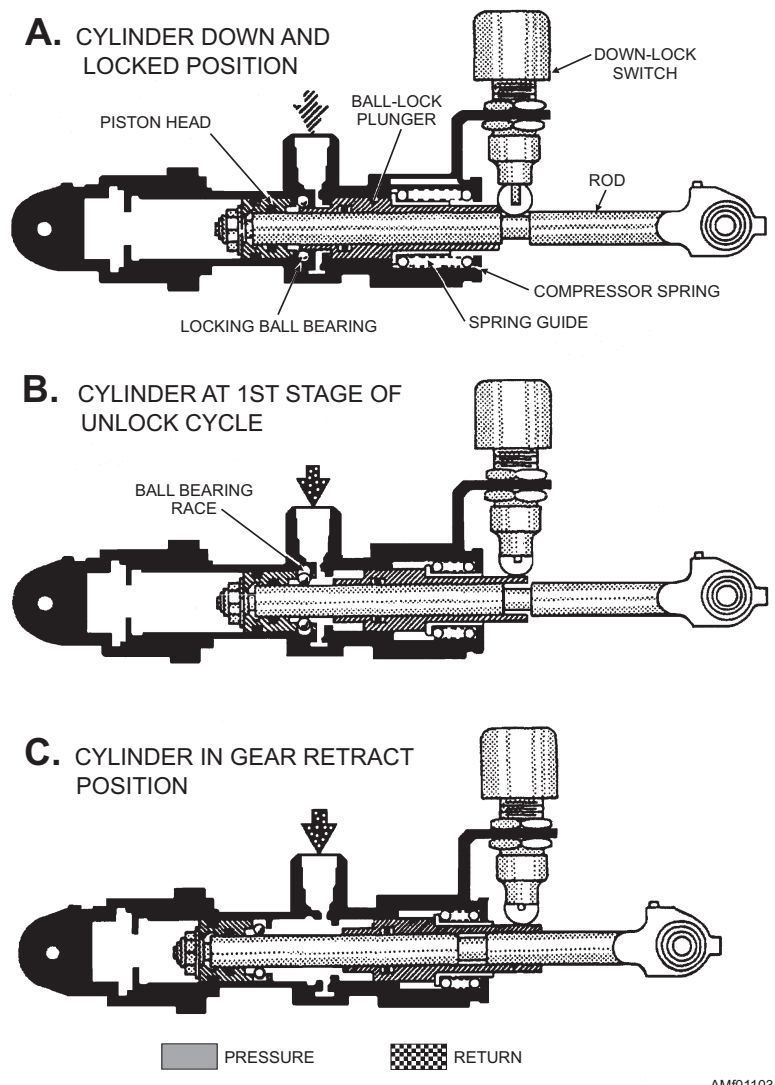

AMF01103

Figure 11-3.—Cutaway of a single-action, ball-lock actuating cylinder.

compression spring, and down-lock switch. The operation of the ball-lock actuator is described in the following paragraphs.

When the landing gear is down and locked, the ball-lock actuator will be in the position shown in view A of figure 11-3. Notice the locking ball bearings are being held in the ball bearing race detents by the inner lip of the ball-lock plunger. Since no hydraulic pressure exists while in this position, the spring-loaded, ball-lock plunger is held in its retracted position, allowing the down-lock switch to be actuated by the groove portion of the piston shaft.

When the landing gear selector valve is positioned to its retracted (UP) position, pressurized fluid is allowed to enter the actuator through its only port. This pressurized fluid forces the ball-lock plunger to the right, which simultaneously allows the ball bearings to drop free from their detents in the bearing race and actuate the down-lock switch, as shown in view B of figure 11-3. As soon as the locking ball bearings are released, the piston shaft assembly retracts, as shown in view C of figure 11-3, and unlocks the landing gear. When the landing gear completes its UP cycle, the selector valve returns to neutral, trapping hydraulic fluid within the actuator until the next cycle begins.

FINGER-LOCK ACTUATOR.—The actuating cylinder shown in figure 11-4 is a double-action, two-port, finger-lock, balanced actuator. This type of actuator is currently installed as a main landing gear component on some aircraft. It incorporates an inner cylinder to equalize the displacement of fluid on either side of the piston.

As shown in view A of figure 11-4, an integral, finger-type, spring-loaded, mechanical lock is also incorporated within the actuator to lock the piston shaft assembly in the extended position. The finger-lock actuator has a down-limit switch mounted on and through the cylinder area, which indicates when the landing gear is down and locked; also, an added feature that is common on landing gear actuators is an integral shuttle valve. The shuttle valve allows connection of both the normal extension hydraulic fluid line and the emergency pneumatic extension pressure line. The operation of the finger-lock actuator is described in the following paragraphs.

When the pilot positions the selector valve in the landing gear retracted position, view A of figure 11-4, hydraulic pressure is directed to the cylinder's retract port. Hydraulic pressure entering the cylinder overcomes piston spring force, which permits the

locking fingers to open as the piston shaft assembly is retracted into the cylinder.

During normal extension of the landing gear (view B of figure 11-4), hydraulic pressure is directed from the selector valve to the normal extension port of the integral shuttle valve. This pressurized fluid forces the piston towards the extended position. As the piston comes in contact with the locking fingers, hydraulic pressure and spring tension are required to force the piston over the fingers while fully extending the piston shaft assembly. At the same time the piston is being forced over the locking fingers, it contacts the cam-shaped lower end of a toggle shaft, which extends radially into the cylinder area, thereby rotating the shaft. Movement of the toggle shaft is transmitted to the main landing gear down-limit switch, which is attached to the outer surface of the cylinder. This indicates the cylinder is in the locked position.

Control Surface Actuating Cylinder

Actuators are used in conjunction with power-operated flight control systems. Their function is to assist the pilot in handling the aircraft, in the same way as power steering aids in handling an automobile.

In a power-operated flight control system, all the force necessary for deflecting the control surface is supplied by hydraulic pressure. A hydraulic actuator incorporated in the control linkage operates each movable surface. Some aircraft manufacturers refer to these units as power control cylinders; however, all flight control system actuators and power control cylinders perform the same function, and are similar in principle of operation.

A typical flight control surface actuator is shown in figure 11-5. This is a tandem-type hydraulic unit, which means, in this case, that two control valves are incorporated within a common housing. One of the control valves is connected to the aircraft's primary flight control hydraulic system, while the other is connected to a separate hydraulic system.

This is a typical arrangement since Navy specifications require two independent hydraulic systems for operation of the primary flight control systems on all high-performance aircraft.

Although a synchronizing rod interconnects the two control valves in the actuator mechanically, they are not interconnected hydraulically. The purpose of the synchronizing rod is to equalize the flow of fluid into the actuator piston chambers.

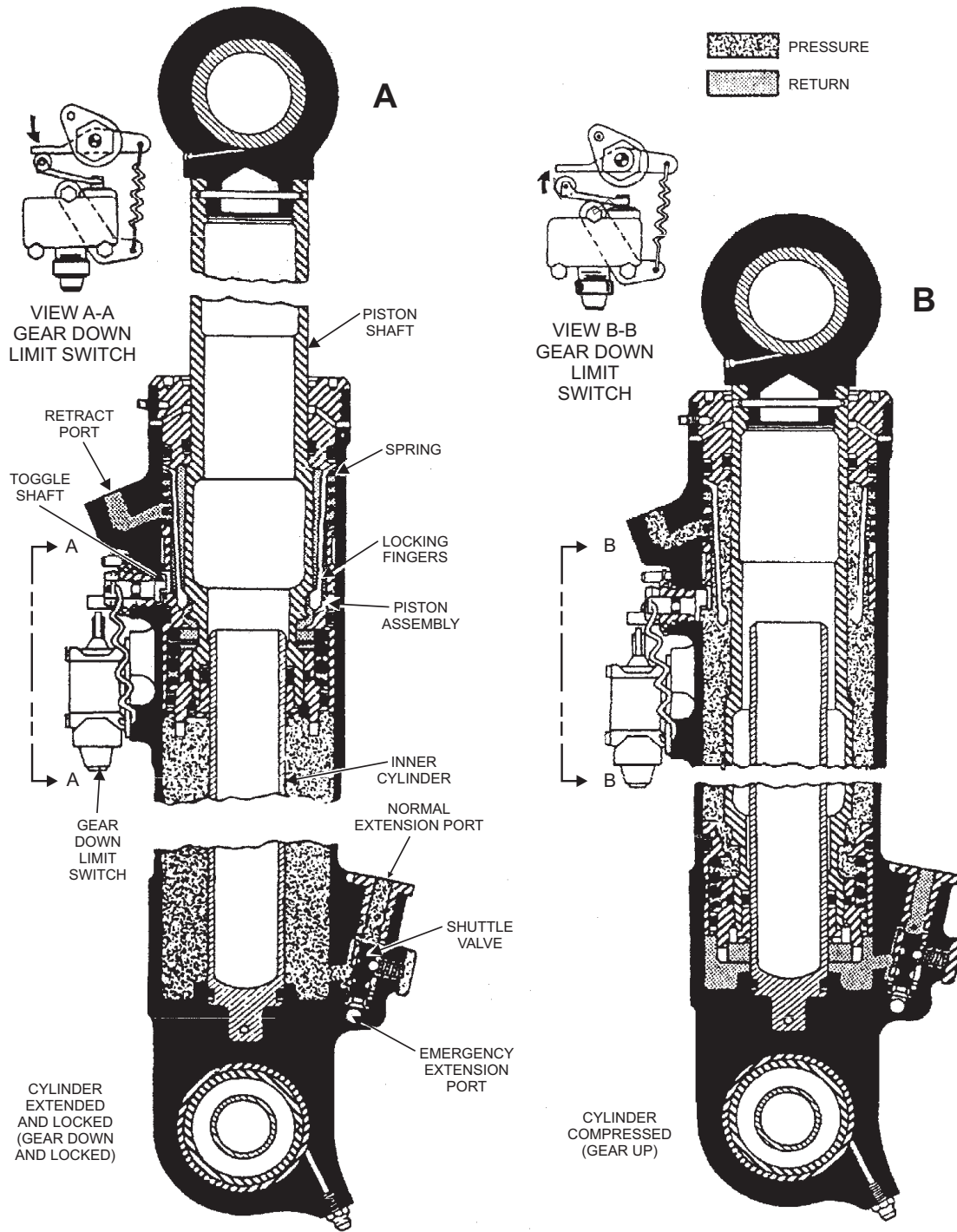

AMf01104

Figure 11-4.—Typical finger-lock actuating cylinder.

Because the two control valves operate independently of each other as far as hydraulic pressure is concerned, failure of either hydraulic system does not render the actuator inoperative. Failure of one system does reduce the output force by

one-half; however, this force is sufficient to permit handling of the aircraft at certain airspeeds (always well above that required for a safe landing).

This complete actuator consists of the two isolated piston chambers, a shaft assembly with two pistons,

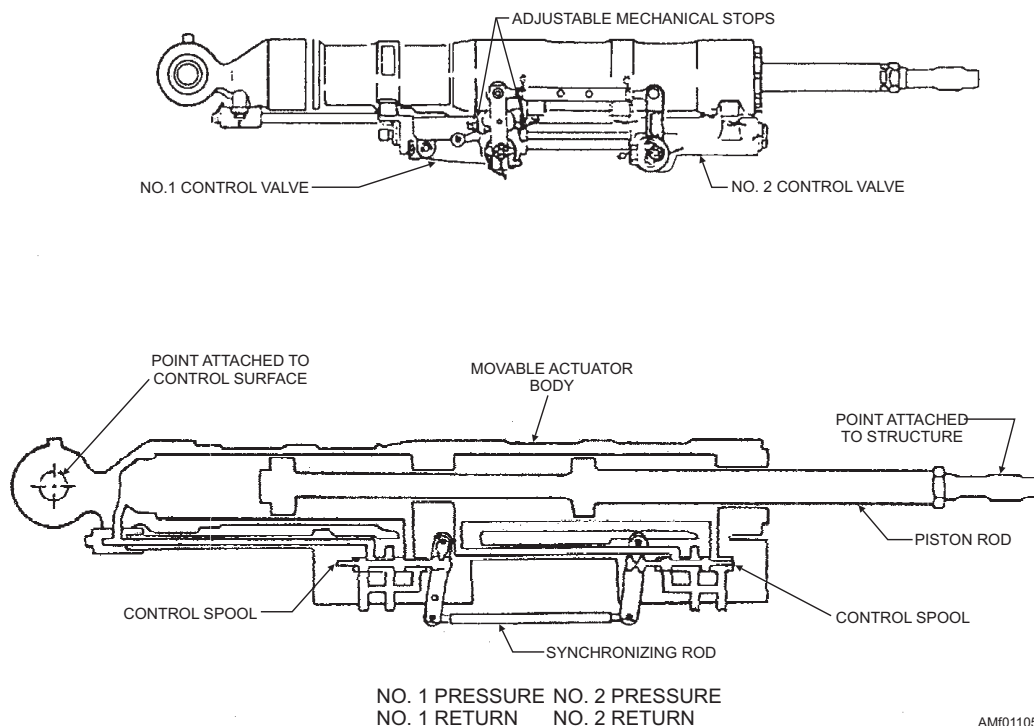

Figure 11-5.—Control surface actuating cylinder.

two end cap assemblies, the two control valves, and the previously mentioned synchronizing rod.

In this particular installation, the piston shaft end is attached to the aircraft structure and remains stationary. The cylinder body is attached to the control surface, and provides control surface deflection by its movement. Two adjustable stops are provided as a means of adjusting actuator movement, thereby limiting the travel of the control surface. When these stops are used in an aileron or elevator control system, one stop limits the UP travel, and the other limits the DOWN travel. In a rudder system, one stop limits the travel to the right, and the other to the left.

MAINTENANCE OF ACTUATING CYLINDERS

During preventive maintenance inspections, you inspect actuating cylinders in accordance with the applicable maintenance requirements cards (MRCs) for the specific aircraft. Actuating cylinders are inspected for leakage and binding. You should clean the exposed portion of the piston shaft with a dry-cleaning solvent, and then wipe it with a clean cloth moistened with hydraulic fluid. All mounting fittings are lubricated with specified grease only.

NOTE: All lubrication fittings and lubrication areas must be cleaned prior to lubrication, and all excess lubricants must be removed at its completion.

External leakage is the most common trouble encountered with actuating cylinders. Static or dynamic seals can cause this. Static seal leakage around end caps or fittings may be stopped by tightening the affected components or replacing the leaking seal. Dynamic seal leakage around an actuator shaft will require seal replacement. Refer to the appropriate maintenance instructional manual (MIM) or O3 Manual for specific maintenance instructions.

WARNING

Applying too much torque while tightening fittings or other components under pressure may cause catastrophic failure. Such failures can result in injury to personnel or damage to the aircraft.

Internal leakage is harder to detect. This leakage is usually caused by failure of piston seals, and will require repair. Weak, sluggish, or slow movement of the actuator usually indicates internal leakage. Refer to the appropriate MIM or O3 Manual for repair

instructions. This problem is usually resolved by replacement of the actuator. After the repairs are made, you must test the actuator to verify its performance.

- Q11-1. What unit transforms hydraulic fluid pressure into mechanical force, which performs work by moving some mechanism?*
- Q11-2. Aircraft actuating cylinders are used when which of the following mechanism movements are required?*
- Q11-3. If hydraulic pressure is used to move a single-acting actuating cylinder in only one direction, what force is used to move it in the opposite direction?*
- Q11-4. The operation of a single-acting, spring-loaded, piston-type actuating cylinder is normally controlled by what component?*
- Q11-5. Most piston-type actuating cylinders are of what type?*
- Q11-6. An unbalanced, double-acting, piston-type actuating cylinder uses a directional control valve capable of directing fluid in what total number of ways?*
- Q11-7. When the cylinder is in the down and locked position, the locking ball bearings are held in the locking position by what means?*
- Q11-8. To equalize the displacement of fluid on either side of the piston, a double-action, finger-lock actuator incorporates what component?*
- Q11-9. During normal extension of a landing gear finger-lock actuator, what forces move the piston over the fingers?*
- Q11-10. In a power-operated flight control system, all the force necessary for deflecting the control surface is supplied by what type of pressure?*
- Q11-11. A tandem-type, control surface, actuating cylinder uses a synchronizing rod for what purpose?*
- Q11-12. In the maintenance of actuating cylinders, what is the most common trouble encountered?*

HYDRAULIC MOTORS

LEARNING OBJECTIVE: Identify typical hydraulic motors.

Hydraulic motors are used to convert hydraulic pressure into rotary mechanical motion. The type of hydraulic motor used in naval aircraft is similar in general design and construction to the piston-type pumps. The difference in the operation of a hydraulic motor and a hydraulic pump is as follows: In the operation of a pump, when the drive shaft is rotated, fluid is drawn into one port and forced out the other under pressure. This procedure is reversed in a hydraulic motor. By directing fluid already under pressure into one of the ports, pressure will force the shaft to rotate. Fluid will then pass out the other port, and back to return. The rotary mechanical force provided by the motor can be used to drive a gearbox, torque tube, or jackscrew.

Hydraulic motors are commonly used to operate the wing flaps and radar equipment. Hydraulic motors may be operated in either direction of rotation, with the rotation being controlled by the direction of flow to the valve plate ports. The direction of rotation may be instantly reversed without damaging the motor. A selector valve controls the direction of flow.

A typical hydraulic motor is shown in figure 11-6. This is a nine-cylinder, fixed-stroke motor. It is self-lubricating and requires no line maintenance other than periodic visual inspection for leakage. The motor is equipped with a stub tooth spline, suitable for engagement into the mechanical linkage of the unit to be actuated on the aircraft.

Any shop maintenance that must be performed on a hydraulic motor should be done in accordance with instructions contained in the applicable Overhaul Instruction Manual (03 series).

Q11-13. What type of motor converts hydraulic pressure into rotary mechanical motion?

Q11-14. Hydraulic motors are commonly used to operate what aircraft equipment?

VALVES

LEARNING OBJECTIVE: Identify typical valves in a basic actuating system.

A valve is defined as a device that provides control of the flow or pressure in a hydraulic system. There are many types of valves, such as selector valves, check valves, sequence valves, shuttle valves, restrictor valves, pressure-reducing valves, and hydraulic fuses. While the basic function for each type of valve is

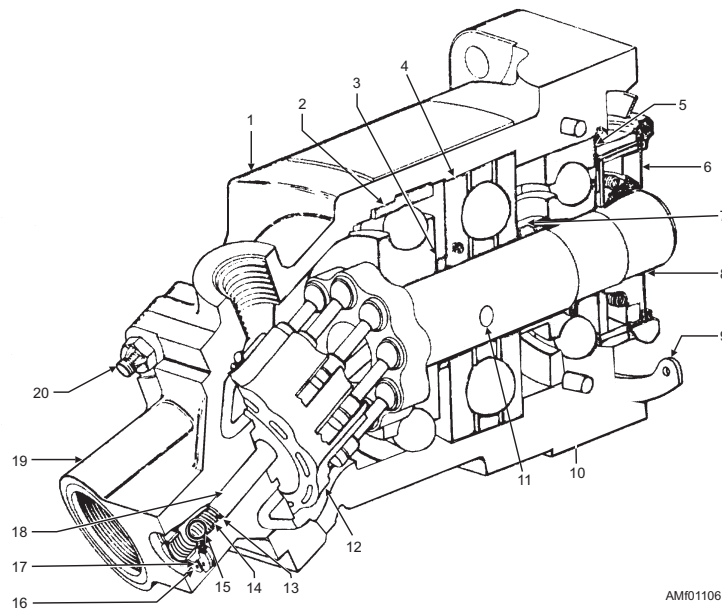

Figure 11-6.—Typical hydraulic motor.

- | | | | |
|------------------------|-----------------------------------|---------------------------------|--------------------------------|
| 1. Housing | 6. Oil seal assembly | 11. Universal link retainer pin | 16. Retaining ring |
| 2. Drive shaft bearing | 7. Bearing spacer | 12. Cylinder block | 17. Cap |
| 3. Bearing spacer | 8. Shaft and piston subassembly | 13. Spring retaining washer | 18. Cylinder bearing ring |
| 4. Thrust bearing | 9. Retaining ring | 14. Spring | 19. Valve plate |
| 5. Drive shaft bearing | 10. Bearing and oil seal retainer | 15. Cap retaining ring | 20. Valve plate mounting plate |

similar, the design and construction may be very different.

SELECTOR VALVES

Selector valves are used in a hydraulic system to direct the flow of fluid. A selector valve directs fluid under system pressure to the desired working port of an actuating unit (double-acting), and, at the same time, directs return fluid from the opposite working port of the actuating unit to the reservoir.

Some aircraft maintenance instruction manuals (MIMs) refer to selector valves as control valves. It is true that selector valves may be placed in this classification, but you should understand that all control valves are not selector valves. In the strict sense of the term, a selector valve is one that is engaged at the will of the pilot or copilot for the purpose of directing fluid to the desired actuating unit. This is not true of all control valves.

Selector valves may be located in the pilot's compartment and be directly engaged manually through mechanical linkage, or they may be located in some part of the aircraft and be engaged by remote control. Remote-controlled selector valves are generally solenoid operated.

The typical four-way selector valve has four ports—a pressure port, a return port, and two cylinder (or working) ports. The pressure port is connected to the main pressure line from the power pump, the return port is connected to the reservoir return line, and the two cylinder ports are connected to opposite working ports of the actuating unit.

Three general types of selector valves are discussed in this course. They are the poppet, slide, and solenoid-operated valves. Practically all selector valves currently in use come under one of these three general types.

Poppet-Type Selector Valve

Poppet-type selector valves are manufactured in both the balanced and unbalanced design. An unbalanced poppet selector valve offers unequal working areas on the poppets. The larger area of the poppet is in contact with the working lines of the system; consequently, when excessive pressure exists within the working lines due to thermal expansion, the poppet will open. This action allows the excessive pressurized fluid to flow into the pressure line, where it is relieved by the main system relief valve.

The balanced poppet selector valve has equal poppet areas. The poppets will remain in the selected position during thermal expansion of working line fluid. For this reason, thermal relief valves are installed in working lines that incorporate balanced poppet selector valves.

Figure 11-7 shows a typical four-port poppet selector valve. This is a manually operated valve, and

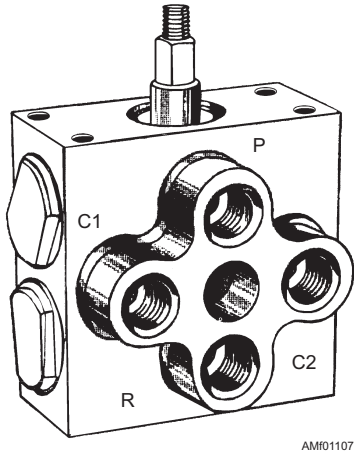

Figure 11-7.—Poppet-type selector valve.

consists of a group of conventional spring-loaded poppets. The poppets are enclosed in a common housing and interconnected by passageways to direct the flow of fluid in the desired direction.

Cams on a camshaft, as shown in figure 11-8, actuate the poppets. They are arranged so that rotation of the shaft by its controlling lever will open the proper combination of poppets to direct the flow of hydraulic fluid to the desired port of the actuating unit. At the same time, fluid will be directed from the opposite port of the actuating unit, through the selector valve, and back to the reservoir.

All poppet-type selector valves are provided with a stop for the camshaft. The stop is an integral part of the shaft, and strikes against a stop pin in the body to prevent overrunning. A poppet selector valve housing usually contains poppets, poppet seats, poppet springs, and a camshaft.

When the camshaft is rotated, either clockwise or counterclockwise from neutral, the cam lobes unseat the desired poppets and allow a fluid flow. One cam lobe operates the two pressure poppets, and the other

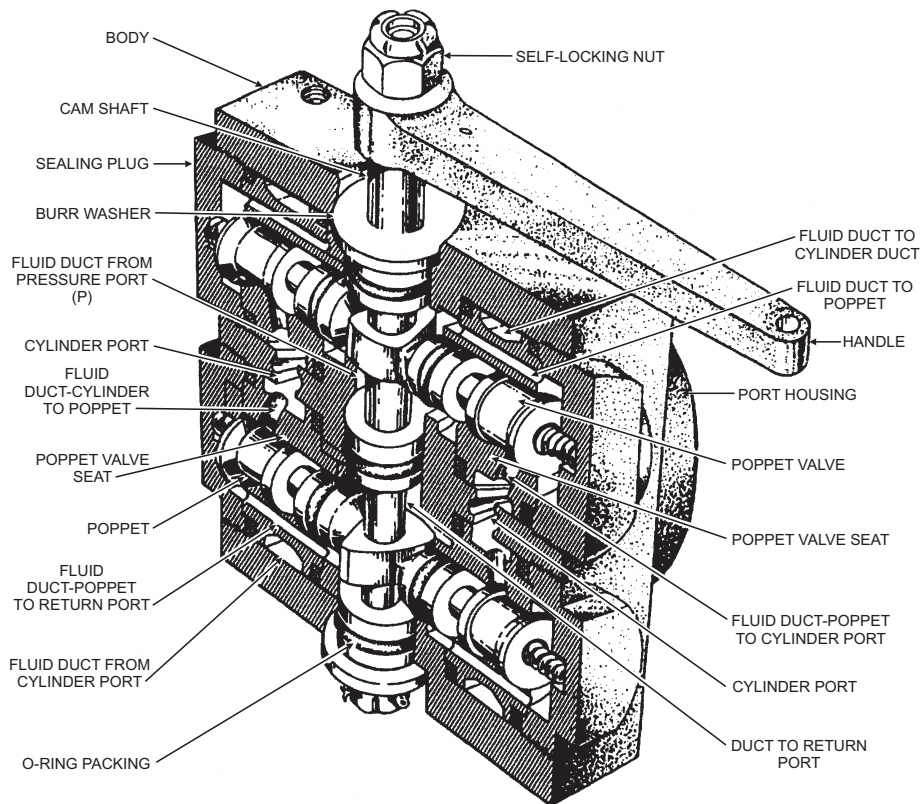

Figure 11-8.—Cutaway view of selector valve body.

lobe operates the two return poppets. To stop the rotation of the camshaft at an exact position, a stop pin is secured to the body, and extends through a cutout section of the camshaft flange. This stop pin prevents overtravel by ensuring that the cam lobes stop rotating when the poppets have been unseated as high as they can go, where any further rotation would allow them to return to their seats.

The poppet-type selector valve has three positions—neutral and two working positions. In the neutral position, the camshaft lobes are not contacting any of the poppets. This position assures that the poppet springs will hold all four poppets firmly seated. With all poppets seated, there is no fluid flow through the valve. This action also blocks the two cylinder ports, so when this valve is in neutral, the fluid in the unit system is trapped. To allow for thermal expansion buildup, thermal relief valves must be installed in both working lines.

You can rotate the camshaft by moving the control handle in either direction from neutral. This action rotates the lobes, which unseat one pressure poppet and

one return poppet. See figure 11-9. The valve is now in a working position. Pressure fluid, entering the pressure port, travels through the vertical fluid passages in both pressure poppet seats. Since the cam lobe unseats only one pressure poppet, the pressure fluid flows past this open poppet to the inside of the poppet seat. From there it flows out the diagonal fluid passages, and then out one cylinder port and to the actuator.

Return fluid coming from the actuator is coming in the other cylinder port, through the diagonal fluid passages, past the unseated return poppet, through the vertical fluid passages, and out the return port to the system reservoir. By rotating the camshaft in the opposite direction until the stop pin hits, the opposite pressure and return poppets are unseated, and the fluid flow is reversed. This causes the actuator to move in the opposite direction.

Selector valves should be checked periodically for leakage and security of mounting. The operating linkage should be inspected for ease of operation.

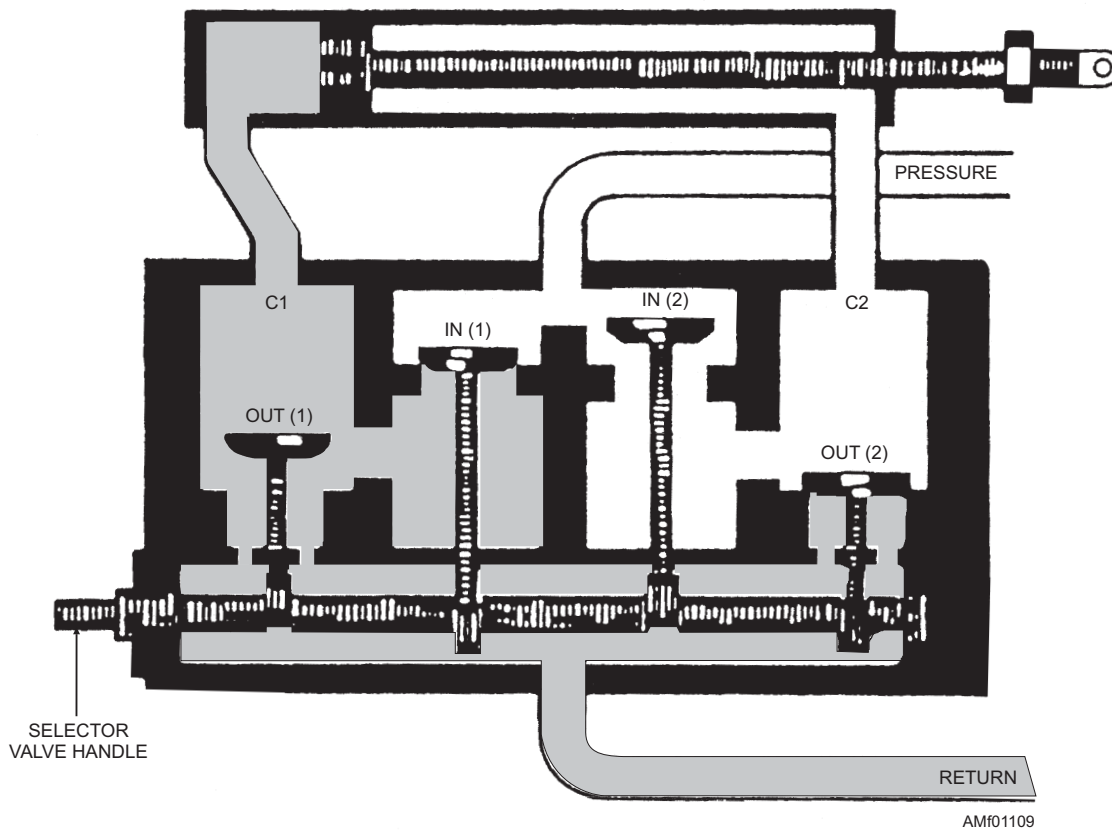

Figure 11-9.—Working view of a poppet-type selector valve.

Malfunctioning selector valves are usually the result of foreign particles or damaged parts. A malfunctioning valve should be removed and checked for free movement of the camshaft. The valve may be disassembled and all parts cleaned with clean hydraulic fluid. O-rings should be replaced while the valve is disassembled.

Damaged or worn O-rings may cause both external and internal leakage. A damaged gasket under the sealing plug or the end packing on the camshaft could cause external leakage. Internal leakage could be caused by damaged center packing on the camshaft, a damaged bottom gasket on the poppet seat, or damaged O-ring packing on the poppet.

NOTE: All selector valves that require repair or adjustment must be done in accordance with the

applicable MIM or O3 Manual. After repair or adjustment, all valves must be tested for proper operation and leakage.

Slide-Type Selector Valve

The slide-type selector valve is probably the most durable and trouble-free valve currently in use. Some manufacturers refer to this type valve as a piston or spool type. Figure 11-10 shows a cutaway view of a typical four-port slide-type selector valve. The main parts of the valve consist of a body, sleeve, slide, detent springs, and the necessary packings and gaskets.

The valve body is cast aluminum alloy. It has four fluid ports—pressure, return, and two cylinder ports.

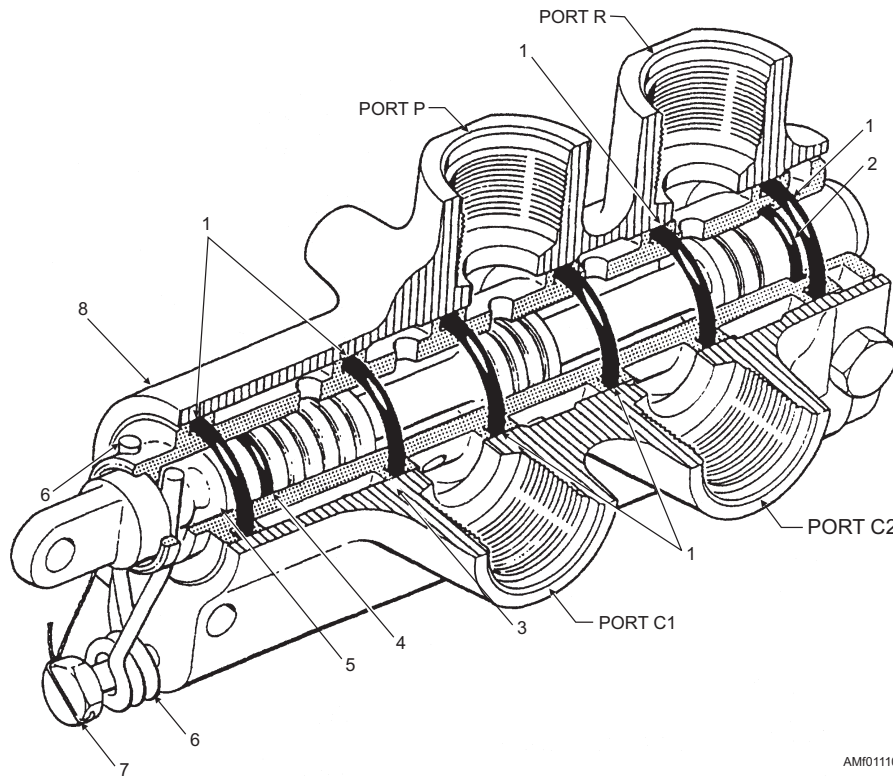

AM01110

Figure 11-10.—Slide-type selector valve.

- | | |
|-------------------|--------------------------|
| 1. O-ring gasket | 5. Slide |
| 2. O-ring packing | 6. Detent spring |
| 3. Sleeve | 7. Spring retaining bolt |
| 4. O-ring packing | 8. Body |

A large bore has been drilled lengthwise through the body, and all four fluid ports connect into this main bore at intervals along its length. There is also a drilled passageway in the body that runs alongside the main bore. This passageway is used to connect one of the cylinder ports to the return port.

A hollow steel sleeve (3) fits into the main bore of the body. Around the outside diameter of the sleeve are six O-ring gaskets. As the sleeve is inserted into the main bore, these O-rings form a seal between the sleeve and the body. This creates five chambers around the sleeve, and each chamber is formed by two of the O-ring gaskets. Each one of these chambers is lined up with one of the fluid ports in the body. The drilled passageway in the body accounts for the fifth chamber, which results in having the two outboard chambers connected to the return port. The sleeve has a pattern of holes drilled through it to allow fluid to flow from one port to another. A series of holes are drilled into the hollow center of the sleeve between each O-ring gasket.

A steel slide (5) or spool is machined so the largest diameter portions have a close tolerance fit in the sleeve. Typically, the slide has three raised, machined portions known as land areas. These areas usually have several grooves machined into them around the circumference, breaking each area into several lands. The lands (and grooves), in concert with the close-machined tolerances, provide for easy, smooth operation, long service, and no leakage.

One end of the slide is connected to the control handle in the cockpit through mechanical linkage. When the control handle is moved, it will then position the slide within the sleeve. The slide lands then line up different combinations of fluid ports, thereby directing a flow of fluid through the valve.

On the end of the slide, next to the eye, are three grooves called "detents." These detents are used to lock the slide in the exact position needed to properly direct the fluid flow.

The detent spring (6) is a clothespin-type spring, secured to the end of the body by a spring retaining bolt (7). The two legs of the spring extend down through slots in the sleeve and fit into the detents. The slide is gripped between the two legs of the spring. To move the slide, enough force must be applied to spread the two spring legs and allow them to snap back into the next detent, which is another position.

Because of the very close fit between the slide and sleeve, the most common cause of failure or

malfunction is the presence of dirt or foreign matter. Foreign matter could result in binding of the slide, scratching the machined surface, and damage to O-rings. Originally, these valves were provided with protective boots on both ends of the slide to prevent dirt or corrosion from getting on the exposed machined surface, where it would be carried into the valve when the slide was moved. These protective boots usually are missing on valves currently issued, leaving the machined surface exposed. As a preventive measure, in place of the boots, a light film of hydraulic fluid should be applied to the exposed areas of the slide. Primarily, this oil film is to prevent corrosion, but it helps to prevent any entry of foreign matter into the valve. Proper linkage adjustment is necessary because linkage that is too long or too short will prevent the detent spring from locking the slide in the correct position.

If it becomes necessary to test this valve under pressure to determine the cause of malfunction, it is important to first check the MIM for the particular installation. A slight amount of internal leakage is permitted in the working positions, and this should not be mistaken for faulty operation.

Solenoid-Operated Selector Valve

A solenoid-operated selector valve is an electrically controlled valve. Solenoid-operated selector valves may be either the slide type or the poppet type. They differ from the manually controlled valves previously described in that they are electrically controlled by one or more solenoids contained within the valve.

A solenoid may be defined as a hollow or tubular-shaped electric coil, made up of many turns of fine insulated wire that possesses the same properties as an electromagnet. The hollow core imparts linear motion to a movable iron core (or plunger) placed within the hollow core of the solenoid.

Solenoid-operated selector valves are fast becoming the most commonly used valves on naval aircraft. Figure 11-11 is a cutaway view of the valve, showing all the principal components. The body is made of cast aluminum alloy and contains four fluid ports. These are the pressure port, return port, and the two cylinder ports.

The body is bored through lengthwise to receive a slide and sleeve assembly similar to the slide-type valve. All four fluid ports lead into this body bore. Caps or plugs close off the ends.

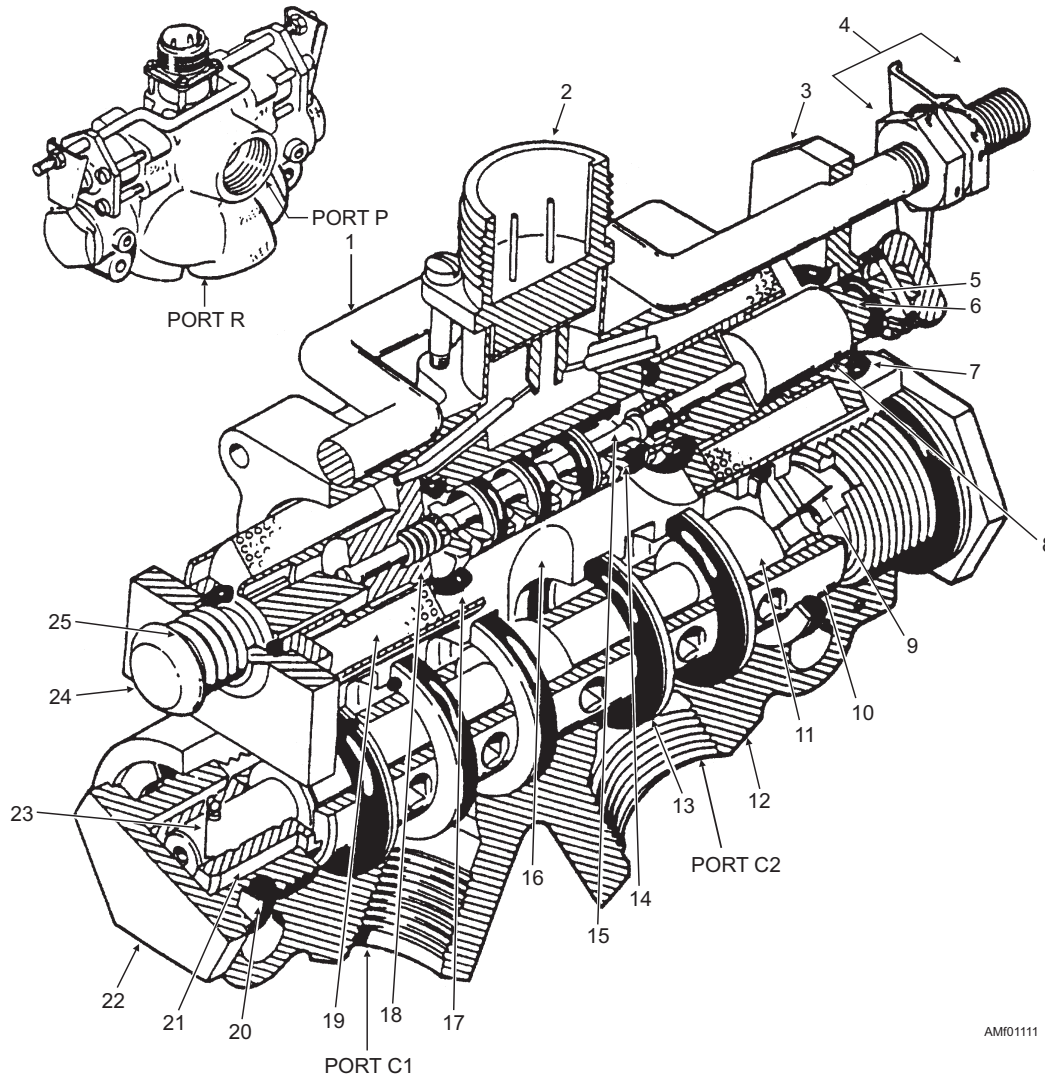

AM101111

Figure 11-11.—Solenoid-operated selector valve.

- | | | | |
|-----------------------|---------------------|----------------------------|----------------------------|
| 1. Override rod | 7. O-ring | 13. O-ring and backup ring | 18. Pilot spring |
| 2. Receptacle | 8. Plunger | 14. Pilot sleeve | 19. Solenoid coil |
| 3. Retainer | 9. Stop | 15. Pilot slide | 20. O-ring and backup ring |
| 4. Lever assembly nut | 10. Selector sleeve | 16. O-ring and backup ring | |
| 5. O-ring | 11. Selector slide | 17. O-ring | |
| 6. Plunger shaft | 12. Valve body | | |

A hollow steel sleeve is pressed into the body bore. There are no flanges or grooves machined on the sleeve, but a pattern of holes has been drilled all around it. These holes are arranged in five rings, along the length of the sleeve, drilled through to the hollow center. When the sleeve is installed in the body, each ring of holes will line up with a fluid port. The return port connects to the two outboard rings of holes. To separate each ring of holes around the outside of the sleeve, six O-ring gaskets are installed in the body bore

at intervals along its length. The sleeve is then inserted through the centers of the O-rings.

A steel slide is fitted inside the hollow sleeve. The slide has three lands, which form a lapped fit to the inside of the sleeve. Fluid will not flow past them. By properly positioning the slide inside the sleeve, the slide lands will connect different fluid ports by opening or closing the rings of holes in the sleeve. The flow of fluid to and from the actuator is directed by the

slide. When the valve is in neutral, the slide is held in the exact center of the sleeve by two coil springs. These springs, working through spring guides, apply equal pressure to each end of the slide. Variation in slide design will determine the valve porting.

To position the slide, apply hydraulic pressure to the working surfaces at each end of it. This pressure is obtained from the pressure port, and is called “bleed pressure.” Body passageways direct this pressure to the ends of the slide. Two solenoid assemblies are used to control the flow of bleed pressure.

A solenoid is installed in each side of the valve, pointing toward the center of the body. The solenoids are tubular in shape, with coil wires wound around a hollow center. Hydraulic fluid can enter the center portion, but cannot reach the coil wires. The solenoids are held in place by threaded caps that screw into the body. The function of these solenoids is to control bleed pressure.

A metal core, called a plunger, is placed in the hollow center of the solenoids. This plunger reacts to the magnetic field created when the solenoid coil is energized. The plunger sits above the level of the coil wires, so that when the solenoid is energized, the plunger is pulled down into the magnetic field. When the plunger is pulled down by the magnetic field, it drives the plunger pin ahead of it. When this happens, the pin opens a passage and relieves bleed pressure from one end of the slide.

During all periodic inspections, selector valves are inspected for security of installation and external leakage. If a malfunction occurs, it must be determined whether the cause is electrical, hydraulic, or material failure. If the aircraft’s hydraulic pressure and electrical current are both normal, remove the selector valve and send it to the supporting AIMD. Use the proper O3 series maintenance publications as a guide to clean, inspect, repair, and test the selector valve.

Testing procedures are thoroughly outlined in the MIMs and O3 series manuals. In general, these procedures will consist of checking for internal and external leakage, and on electrically controlled valves, testing the operation of the solenoids. Before applying pressure, make sure all air is bled out of the valve; otherwise, a leak may exist but go undetected. As the testing procedure begins and after the air has been bled, the selector valve should be subjected to a low pressure for a short period of time to allow all parts to be lubricated and all O-rings to seat. If the valve is to be

stored prior to use, it must be filled with preservative hydraulic fluid, and then drip drained before capping.

CHECK VALVES

The purpose of a check valve is to allow the fluid to flow in only one direction. In some installations, such as brake systems, the check valve confines fluid under pressure within the desired section of the hydraulic system. The valve prevents the fluid from reversing its normal direction of flow. The valve prevents pressure from escaping into adjacent sections of the system.

Automatic Check Valves

Automatic check valves contain a seat on which a movable body (ball, cone, or poppet) seats by means of spring tension. (See figure 11-12.) The valve opens when pressure in the direction of flow (indicated by an arrow on the body of the valve) is strong enough to unseat the movable body. Flow in the reverse direction, along with spring tension, tends to seal the movable body against the valve seat.

When the pressure on the downstream side of the valve exceeds that on the upstream side, the resultant unbalanced force seals the valve closed, as shown in view A of figure 11-12. When the pressure is reversed, the valve is forced open against the tension of the spring, and the fluid flows freely through the valve, as shown in view B of figure 11-12. The tension of the spring is relatively weak, and is intended to be barely sufficient to support the ball in its proper position.

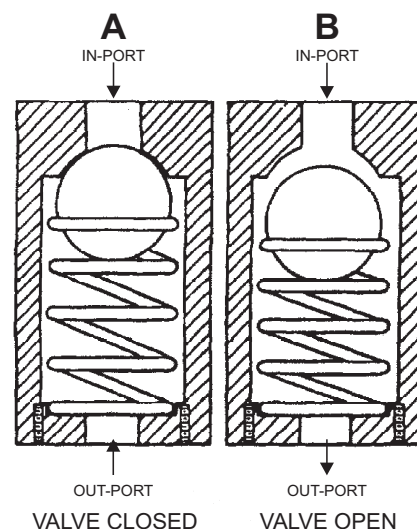

AM101112

Figure 11-12.—Typical check valve.

Bypass Check Valves

Bypass check valves serve the same purpose as automatic check valves, but are so constructed that they may be opened manually to allow the flow of fluid in both directions. An example of the possible use of a bypass check valve is in the line between the hand pump and the accumulator. Installation of a bypass check valve in this line would allow hand pump pressure to be directed to either the accumulator or the selector valve.

Maintenance of Check Valves

Check valves require little attention over long periods of time. Leakage may be caused by the presence of a tiny particle of foreign matter between the checking device (ball, cone, or poppet) and its seat. To remove the foreign matter, it is necessary to remove the valve from the aircraft and completely disassemble the valve. If no scratches are found on the valve seat or the checking device, wash all parts in clean hydraulic fluid of the same type as that used in the system.

While the valve is disassembled, inspect the housing and the checking device for evidence of corrosion. Replace the valve if there is corrosion or excessive roughness. A slightly rough surface can be smoothed by buffing. A cone-type check valve may have a tendency to lean to one side, in which case the movable part may dig into the soft aluminum body of the housing and stick there.

When you install a check valve, remember that the arrow marked on the housing must point in the direction of the flow of the fluid through the valve. Before you remove a check valve from a line, it is good practice to mark the adjacent structure, indicating the direction in which the arrow points. Also, observe the following precaution during installation of check valves: Grip the wrench flats of the check valve at the

end to which the connecting tubing is being installed. Do not grip the opposite end. This will prevent the possibility of distorting the valve body, causing the valve to leak.

SEQUENCE VALVES

Sequence valves are used to control a sequence of operations; they ensure that actuating units operate at the proper time and in the proper sequence. Sequence valves may be mechanically operated or pressure-operated valves. An example of the use of a sequence valve is in a landing gear actuating system.

In a landing gear actuating system, the landing gear doors must open before the landing gear starts to extend. Conversely, the landing gear must be retracted before the doors close. A sequence valve installed in each landing gear actuating line performs this function.

Sequence valves may be installed in one or both cylinder lines of an actuating system, depending upon the type of action desired. A direct line will go to the first unit to be operated, and a branch line goes from the sequence valve to the second unit.

Mechanically-Operated Sequence Valve

The body of the mechanically-operated sequence valve (fig. 11-13) is usually aluminum, and contains all the working parts. As for the number and location of the fluid ports, there are many variations, depending upon how the valve is to be used. At least two ports are needed. Some models have four ports, and those not needed are plugged. The valve shown in figure 11-13 has two ports.

A contact plunger extends from the body. The plunger is held in the extended position by a plunger spring. The valve is mounted so that the plunger will be depressed by the first unit operated.

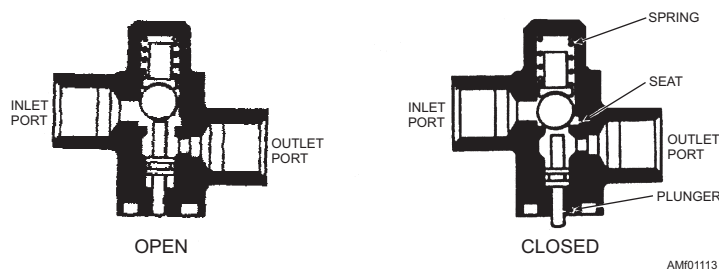

Figure 11-13.—Typical sequence valve.

A check valve, either a poppet or ball, is installed between the fluid ports of the body, and is held against a seat by the check valve spring. The seated check valve spring prevents fluid flow through the valve. The plunger, driven into the valve by the first unit, unseats the check.

The balanced sequence valve will not permit fluid flow in either direction unless the plunger is depressed. This check valve, with equal working areas (balanced), cannot be unseated by fluid pressure in either direction. Thermal relief valves are needed in this system.

The unbalanced valve can be unseated by fluid pressure below it without having the plunger depressed. This movement allows thermal expansion to be relieved. Thermal relief valves are NOT needed in this system.

Pressure from the selector valve goes directly to the first unit. To operate the second unit, fluid must pass through the sequence valve, which it can do only when the check valve is unseated. On completing its operation, the first unit depresses the plunger on the sequence valve, which unseats the check valve and allows fluid to flow through the valve to second unit. Thus, the second unit cannot operate until the first unit operation is complete. In reverse, when contact force is removed from the plunger, the spring extends it and the check valve reseats.

Improper adjustment of plungers on the mechanical-type sequence valve is the most common cause of trouble. If the adjustment is off, it could cause the second unit to operate too soon or not at all. The adjustment is made either on the plunger of the sequence valve or the striker that depresses the plunger.

Adjustment should be checked at every periodic inspection. If a valve leaks internally, disassemble, clean, and inspect the check valve and its sealing surface. Replace faulty O-rings. Internal leakage could cause the second unit to operate before it should.

Pressure-Operated (Priority) Sequence Valve

The pressure-operated sequence valve, also called a priority valve, looks like a check valve externally. Like a check valve, an arrow indicates the installation position. Figure 11-14 shows this valve installed in a wing fold system.

During the wing folding cycle, pressure-operated (priority) valves sequence the movement of the

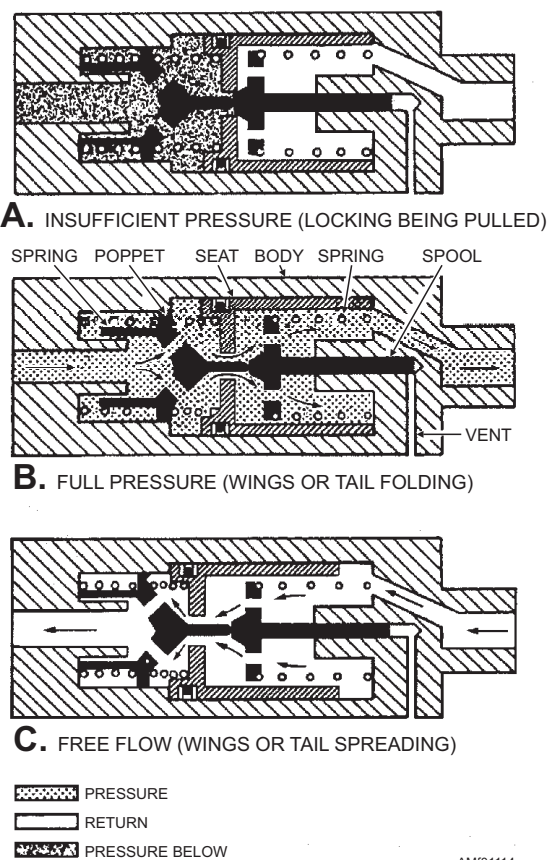

Figure 11-14.—View of priority valve.

lockpins and fold actuators. These valves ensure lockpin actuation before fold actuator operation. This completely automatic valve consists of a body containing a spool, seat, poppet, related springs, seals, and an end cap.

When the wing fold selector valve is in the fold position, it directs fluid both to the wing lockpin and to the pressure-operated sequence (priority) valve. System pressure drops in the wing fold system because of the amount of pressurized fluid needed to actuate the lockpins. This lowers pressure below that needed to open the pressure-operated (priority) valve.

View A of figure 11-14 shows insufficient pressure to unseat the spool. When lockpins have completed their travel, system pressure builds until it overcomes spring tension and causes the poppet to unseat the spool (view B of fig. 11-14). Fluid then flows freely through the valve to the wing fold actuators.

View C of figure 11-14 shows the free-flow position of the valve. When spreading the wings, return fluid moves the seat from the spool compressing

the poppet spring, which causes the poppet to bottom and allows free flow of fluid through the valve.

SHUTTLE VALVES

All aircraft incorporate emergency systems that provide alternate methods of operating essential systems required to land the aircraft safely. These emergency systems usually provide pneumatic or hydraulic operation of the essential systems; however, in some cases due to the design, they may be operated satisfactorily through mechanical linkage. When you use the pneumatic or hydraulic emergency system, that pressure must be directed to the unit concerned; emergency pressure must not enter the normal system, especially if the pneumatic type system is used. To allow operating pressure to reach the actuating unit and still not enter the other system, a shuttle valve is installed in the working line to the actuating unit. The main purpose of the shuttle valve is to isolate the normal system from the emergency system.

Shuttle valves are located close to the actuating unit concerned. This location reduces to a minimum the units to be bled and isolates as much of the normal system from the emergency system as possible. In some installations, the shuttle valve is an integral part of the actuating unit.

A typical shuttle valve is shown in figure 11-15. The body contains three ports—the normal system inlet port, the emergency system inlet port, and the unit outlet port. A shuttle valve used to operate more than one actuating cylinder may contain additional unit outlet ports.

Enclosed in the body is a sliding part called the shuttle. It is used to seal one of the two inlet ports. A shuttle seat is installed at each inlet port. During operation, the shuttle is held against one of these seats, sealing off that port. These parts are held in the body by end caps. An O-ring gasket at each end cap prevents external leakage.

Operation of Shuttle Valves

When a shuttle valve is in the normal operating position, fluid has a free flow from the normal system inlet port to the unit outlet port. The shuttle is seated against the emergency inlet port, and held there by the shuttle spring or by normal system pressure. The shuttle remains in this position until the emergency fluid, gas, or air is released under pressure by the emergency control valve. The application of emergency pressure at the emergency inlet port forces the shuttle from the emergency inlet port seat to the normal system inlet port seat. The emergency pressure

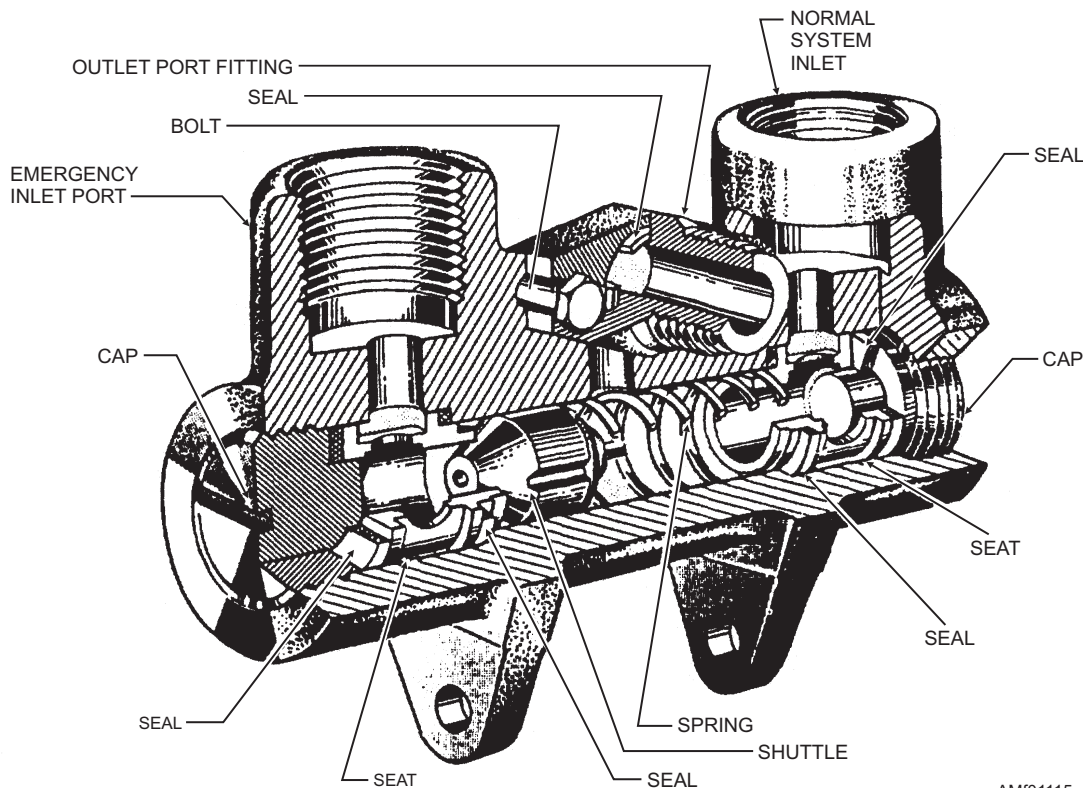

AMf01115

Figure 11-15.—Shuttle valve.

then has a free flow to the unit outlet port, but is prevented from entering the normal system by the shuttle.

Maintenance of Shuttle Valves

Shuttle valve maintenance is generally limited to repairing leakage. Tightening the end caps may generally repair external leakage. If this does not stop excessive leakage, the end cap O-rings should be replaced.

Removing and flushing the unit with clean hydraulic fluid can usually repair internal leakage. Excessive heating is a good indication of internal leakage through a shuttle valve. Excessive cycling of the emergency system pump is also an indication of a leaky shuttle valve.

After an emergency system has been operated, all emergency system pressure should be bled off as soon as possible, and the normal system restored to operation.

RESTRICTORS

Restrictors are used in hydraulic systems to limit the flow of hydraulic fluid to or from actuators where speed control of the cylinders is necessary to provide specific actions. If control in one direction only is desired, a one-way restrictor is used. If restricted fluid flow both to and from an actuating cylinder is necessary, a two-way restrictor is installed.

One-Way Restrictor

One-way restrictors provide reduced hydraulic flow in one direction only, to limit actuating speed of hydraulic cylinders for the purpose of proper timing or sequence of operation. Also, they provide free flow of fluid in the opposite direction to permit the actuating cylinder to actuate at a faster rate of speed during the reverse action of the cylinder.

One-way restrictors are used in some landing gear systems to regulate the speed and sequence of landing gear retraction or extension. If sequenced action (that is, one cylinder to be actuated before other cylinders on the same line) is desired, one-way restrictors are placed in the line upstream of all cylinders except one.

Figure 11-16 shows both the one-way and two-way restrictors. The main parts of a one-way restrictor are the cylindrical body and cap, which contain a

spring-loaded poppet, a cage, and a stainless steel filter element.

The one-way restrictor allows free flow in one direction and restricted flow in the opposite direction. Arrows found on the body of the valve indicate both directions of flow.

In a restricted direction, pressurized fluid entering port R (fig. 11-16) flows through the filter assembly and enters the cage through drilled passages. Fluid from the interior of the cage is forced through the poppet's orifice, thus causing the required metering action.

In the free flow direction, pressurized fluid entering port F overcomes poppet spring tension and allows fluid to flow past the poppet's seat, through drilled passages within the larger flange of the cage, and out through port R.

Two-Way Restrictor

Two-way restrictors are used to limit the flow of hydraulic fluid where it is desirable to retard the action of a hydraulic cylinder in both directions. Figure 11-16 shows two types of two-way restrictors, one of which has a machined orifice with two integral stainless steel filters. The other type shown contains an orifice plate between two stainless steel filters. The filters contained within the restrictors are identical in construction and provide protection in both directions of flow. The filter size specification for the two-way restrictor is identical to those found within one-way restrictors.

Two-way restrictors, regardless of whether they are of the machined orifice type or of the plate orifice type, operate identically. Fluid entering either port is filtered prior to flowing through the orifice, thus protecting the orifice from possible stoppage. As the fluid is metered through the orifice, the prescribed rate flow is directed out the opposite port of the restrictor and to the actuating unit.

Maintenance of Restrictors

Maintenance of restrictors is usually limited to checking for external leakage and the required fluid flow. The specific MIM lists the required fluid flow in gallons per minute (gpm) for each size of orifice being checked. It also specifies the correct pressures to use as well as the required procedures during each check.

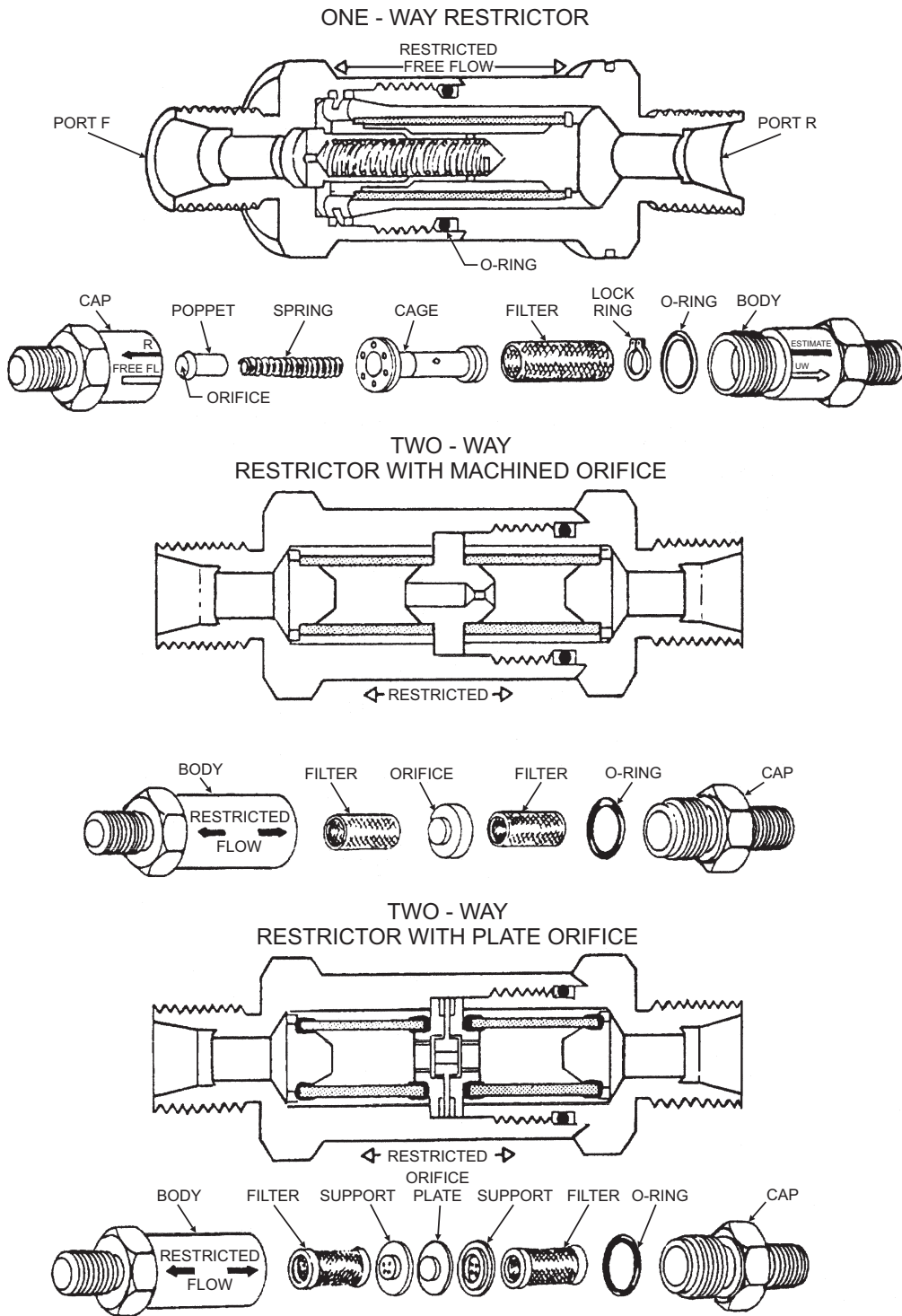

AMf01116

Figure 11-16.—Restrictors.

PRESSURE-REDUCING VALVES

Pressure-reducing valves are used in hydraulic systems where it is necessary to lower the normal system operating pressure a specified amount.

Figure 11-17 shows the operation of a pressure-reducing valve. View A of figure 11-17 shows system pressure being ported to a subsystem through the shuttle and sleeve assembly. Subsystem pressurized fluid works on the large flange area of the shuttle,

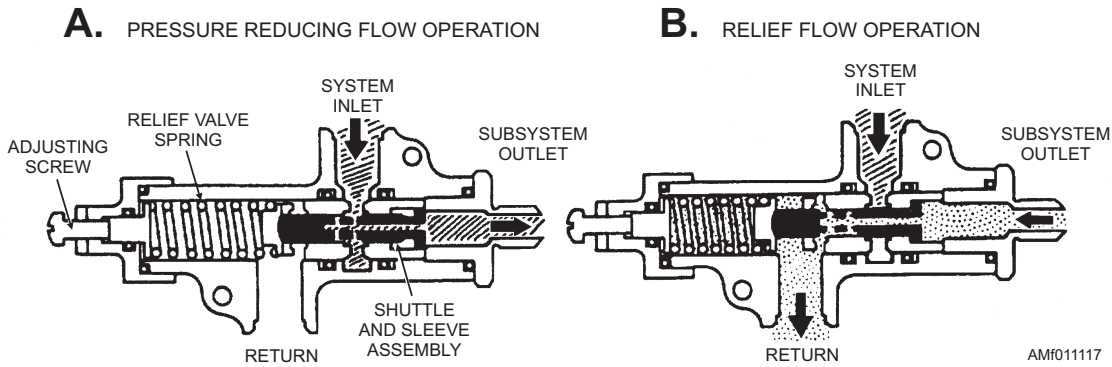

Figure 11-17.—Pressure-reducing valve operational schematic.

which causes the shuttle to move to the left after reaching a specified pressure, thus closing off the normal system. The valve will stay in this position until the subsystem pressure is lowered, at which time the shuttle will move to its prior position and allow the required amount of pressurized fluid to enter the subsystem. During normal operation of the subsystem, the pressure-reducing valve continuously meters fluid to the subsystem.

HYDRAULIC FUSES

A hydraulic fuse is a safety device. Fuses may be installed at strategic locations throughout a hydraulic system. They are designed to detect line or gauge rupture, fitting failure, or other leak-producing failure or damage.

One type of fuse, referred to as the automatic resetting type, is designed to allow a certain volume of fluid per minute to pass through it. If the volume passing through the fuse becomes excessive, the fuse will close and shut off the flow. When the pressure is removed from the pressure supply side of the fuse, it will automatically reset itself to the open position.

Fuses are usually cylindrical in shape, with an inlet and outlet port at opposite ends, as shown in figure 11-18. A stationary sleeve assembly is contained within the body. Other parts contained within the body, starting at the inlet port, are a control head, piston and piston subassembly stop rod, a lock spring, and a lock piston and return spring.

Fluid entering the fuse is divided into two flow paths by the control head. The main flow is between the sleeve and body, and a secondary flow is to the piston. Fluid flowing through the main path exerts a force on the lock piston, causing it to move away from

the direction of flow. This movement uncovers ports, allowing fluid to flow through the fuse.

The movement of the locking piston also causes a lock spring to release the piston subassembly stop rod, thus allowing the piston to be displaced by fluid from the secondary flow. If the flow through the fuse exceeds a specified amount, the piston, moving in the direction of flow, will block the ports originally covered by the locking piston, thus blocking the flow of fluid.

Any interruption of the flow of fluid through the fuse removes the operating force from the lock piston. This allows the lock piston spring to return the piston to the original position, which resets the fuse.

- Q11-15. To relieve pressure created by thermal expansion of the fluid, a system that has a balanced poppet-type selector valve must also incorporate what other type of valve?*
- Q11-16. The poppets of a poppet-type selector valve are actuated by what means?*
- Q11-17. When all four of the poppets of a poppet-type selector valve are held firmly seated by the springs and there is no fluid flow, the valve is in what position?*
- Q11-18. External leakage from a poppet-type selector valve could be caused by what condition?*
- Q11-19. Currently, what type of selector valve is the most durable and trouble-free?*
- Q11-20. The slide-type selector valve has raised, machined portions that are known by what term?*
- Q11-21. A slide-type selector valve has three grooves at the end next to the eye. The grooves are known by what term?*

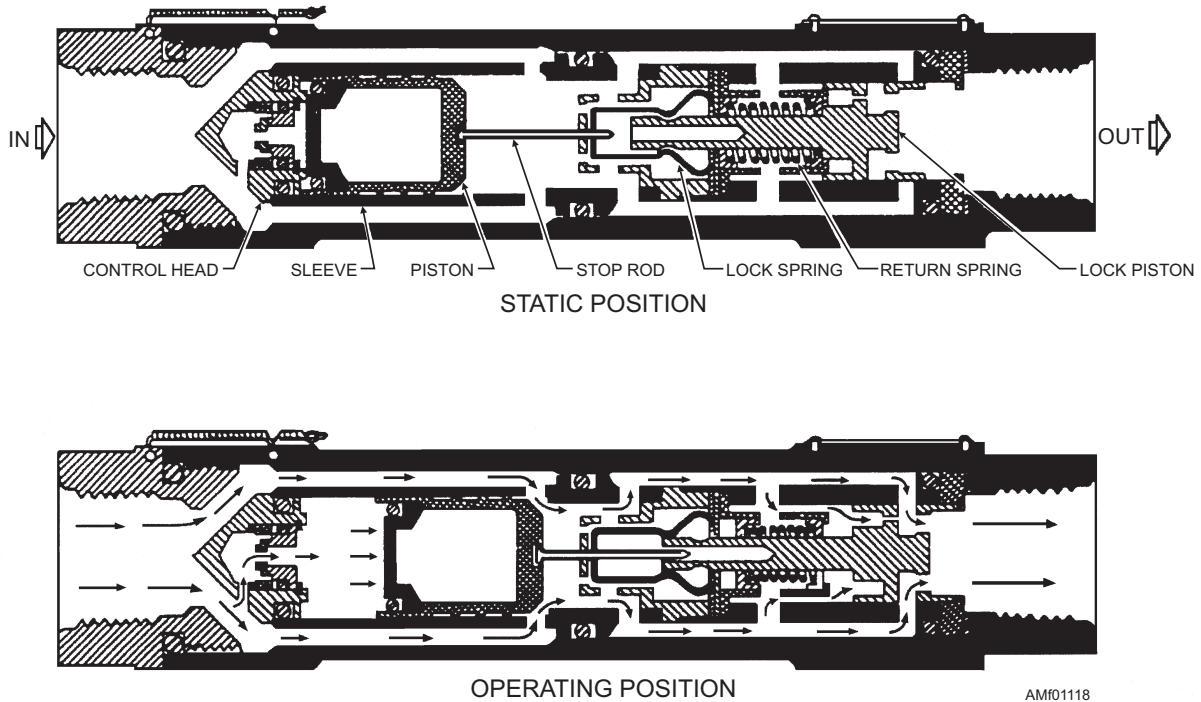

Figure 11-18.—Fuse, operational view.

- Q11-22. A slide-type selector valve should have a light film of hydraulic fluid applied to the exposed areas of the slide primarily for what purpose?
- Q11-23. A solenoid-operated selector valve is controlled by what means?
- Q11-24. A solenoid-operated selector valve directs the flow of fluid to and from the actuator by the use of what component?
- Q11-25. For the proper cleaning, inspection, repair, and testing of selector valves, you should use what series of NAVAIR manuals as a guide?
- Q11-26. When testing a solenoid selector valve, you must bleed all air from the valve before applying pressure for what reason?
- Q11-27. What is the purpose of a check valve?
- Q11-28. A bypass check valve differs from an automatic check valve in what way?
- Q11-29. In what two ways are sequence valves operated?
- Q11-30. What are the two types of mechanically operated sequence valves?
- Q11-31. Trouble associated with a mechanically operated sequence valve is most commonly a result of what problem?
- Q11-32. Isolation of the normal system from the emergency hydraulic system is the main function of what valve?
- Q11-33. Excessive heating of a shuttle valve is a good indication of what type of problem?
- Q11-34. An actuating units speed of operation is controlled by what component?
- Q11-35. To retard the action of a hydraulic cylinder by limiting the flow of fluid in both directions, you should use what device?
- Q11-36. What is the primary purpose of a hydraulic fuse?
- Q11-37. Hydraulic fluid entering a hydraulic fuse is divided into two flow paths by what means?

CHAPTER 12

BASIC HYDRAULIC/PNEUMATIC AND EMERGENCY POWER SYSTEMS

INTRODUCTION

The Navy uses hydraulic and pneumatic power systems extensively in naval aircraft. These systems have a number of favorable characteristics; they eliminate the need for complicated systems of gears, cams, and levers. Also, they transmit motion without the slack or delay inherent in the use of solid machine parts. The fluids used are not subject to breakage as are mechanical parts, and the mechanisms are not subjected to great wear.

The different parts of a fluid power system can be conveniently located at widely separated points, since the forces generated are rapidly transmitted over considerable distances with small loss. These forces can be conveyed up and down or around corners with small loss in efficiency and without complicated mechanisms. Very large forces can be controlled by much smaller ones, and can be transmitted through comparatively small lines and orifices.

If the system is well adapted to the work it is required to perform, and if it is not misused, it can provide smooth, flexible, uniform action without vibration, and it is unaffected by variation of load. In case of an overload, an automatic release of pressure can be guaranteed, so that the system is protected against breakdown or strain. Fluid power systems can provide widely variable motions in both rotary and straight-line transmission of power. The need for control by hand can be minimized. In addition, fluid power systems are economical to operate.

The question may arise as to why hydraulics is used in one application, pneumatics in another, or a combination of hydraulics and pneumatics, also known as *hydropneumatics*, in still another application. Many factors are considered by the user and/or the manufacturer when determining which type of system to use in a specified application. There are no hard and fast rules to follow; however, past experience has provided some sound ideas that are usually considered when such decisions are made. If the application requires speed, a medium amount of pressure, and only a fair amount of control, a

pneumatic system may be used. If the application requires only a medium amount of pressure and a more accurate control, a combination of hydraulics and pneumatics may be used. If the application requires a great amount of pressure and/or extremely accurate control, a hydraulic system should be used.

TYPES OF POWER SYSTEMS

LEARNING OBJECTIVE: Identify the two types of power systems used on naval aircraft.

Hydraulic and pneumatic systems in aircraft contain power systems and several subsystems, the number depending upon the design of the aircraft. The power systems are sometimes called the heart of the system, and the subsystems are known as the muscle. The power systems include all the components normally installed in the system, from the reservoir to, but not including, the selector valve. In pressurized reservoir systems, this also includes all components used to control and direct the pressurizing agent to the reservoir. The utility hydraulic system includes systems used for landing gear, arresting gear, nosewheel steering, and many other systems. In accordance with military specifications, which set up the requirements for aircraft hydraulic systems, all hydraulically operated systems considered essential to flight safety or landing must have provisions for emergency actuation. The hydraulic/pneumatic and emergency power systems are discussed here.

HYDRAULIC/PNEUMATIC POWER SYSTEMS

System design must prevent the failure of a single part, such as a pump, pressure line, or filter, from disabling the aircraft. Special consideration is given to the hydraulic flight control system. System design specifications require two separate systems for operating the primary flight controls. All aircraft that use hydraulically operated flight controls have at least two hydraulic power systems. The systems supply pressure to the utility or normal system in addition to the flight controls. The flight control portion is given

pressure priority by an isolation valve. This design feature isolates nonessential flight functions and prevents loss of hydraulic fluid in the event of utility or normal system rupture.

As a minimum requirement, filters are provided in each system pressure line, return line, and pump bypass or case drain line. Where hydraulic sequencing is critical, each sequence valve is protected from contamination in each direction of flow by a screen-type filter. The filter is usually included as a part of the sequence valve. The pressure line filters clean all fluids before they enter any major equipment. If there are only two hydraulic systems, the primary system is known as the No. 1 power control system (PC-1). The system supplying the other half of the flight control tandem actuating mechanisms and the utility hydraulic system is known as PC-2. The PC-2 system is also known as the combined hydraulic system. If there are three hydraulic power systems, they are generally identified as PC-1, PC-2, and utility system. Some manufacturers label the utility system PC-3. Each system has its own reservoir, hydraulic pump(s), and plumbing.

Military specifications, MIL-H-5440 (series), provide complete design, installation, and data requirements for aircraft hydraulic systems. These specifications provide reference to all other specifications concerning aircraft hydraulic systems. Items such as hose assemblies, hose support requirements, minimum bend radii, types of pumps, and types and classes of systems are found in the specifications.

Many maintenance instruction manuals (MIMs) refer to aircraft hydraulic systems as being open-center or closed-center systems.

Open-Center System

An open-center system is one having fluid flow, but no pressure in the system when the actuating mechanisms are idle. The pump circulates the fluid from the reservoir, through the selector valves, and back to the reservoir. See view A of fig 12-1. The open center system may employ any number of subsystems, with a selector valve for each subsystem. Unlike the closed center system, the selector valves of the open center system are always connected in series with each other. In this arrangement, the system pressure line goes through each selector valve. Fluid is always allowed free passage through each selector valve and

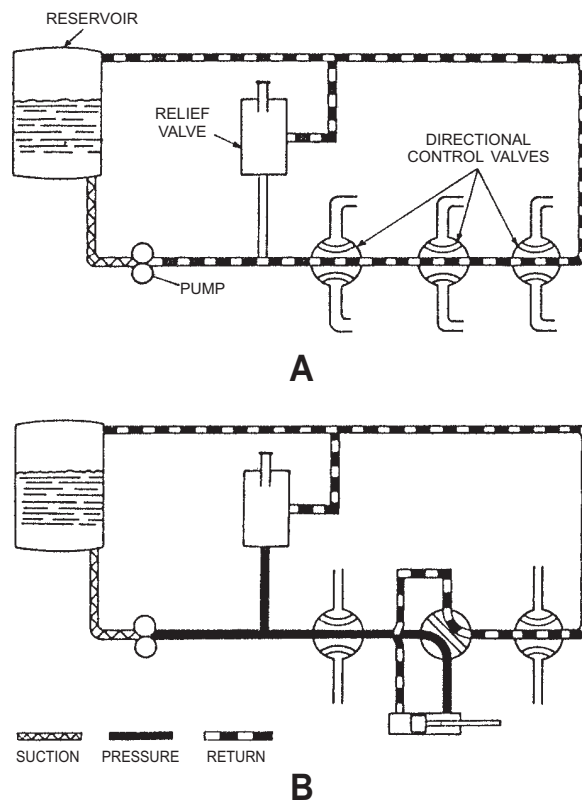

Figure 12-1.—Basic open-center hydraulic system.

AMf12001

back to the reservoir until one of the selector valves is positioned to operate a mechanism.

When one of the selector valves is positioned to operate an actuating device, fluid is directed from the pump through one of the working lines to the actuator. See view B of figure 12-1. With the selector valve in this position, the flow of fluid through the valve to the reservoir is blocked. The pressure builds up in the system to overcome the resistance and moves the piston of the actuating cylinder. The fluid from the opposite end of the actuator returns to the selector valve and flows back to the reservoir. Operation of the system following actuation of the component depends on the type of selector valve being used.

Several types of selector valves are used in conjunction with the open center system. One type is both manually engaged and manually disengaged. First, the valve is manually moved to an operating position. Then, the actuating mechanism reaches the end of its operating cycle, and the pump output continues until the system relief valve relieves the pressure. The relief valve unseats and allows the fluid to flow back to the reservoir. The system pressure remains at the relief valve set pressure until the selector valve is manually returned to the neutral position. This action reopens the open center flow and allows the system pressure to drop to line resistance pressure.

The manually engaged and pressure disengaged type of selector valve is similar to the valve previously discussed. When the actuating mechanism reaches the end of its cycle, the pressure continues to rise to a predetermined pressure. The valve automatically returns to the neutral position and to open center flow.

Closed-Center System

In the closed-center system, the fluid is under pressure whenever the power pump is operating. Figure 12-2 shows a complex closed center system. The power pump may be one used with a separate pressure regulator control. The power pump may be used with an integral pressure control valve that eliminates the need for a pressure regulator. This system differs from the open center system in that the selector or directional control valves are arranged in parallel and not in series. The means of controlling pump pressure will vary in the closed center system. If a constant delivery pump is used, the system pressure will be regulated by a pressure regulator. A relief valve acts as a backup safety device in case the regulator fails. If a variable displacement pump is used, system pressure is controlled by the pump's integral pressure mechanism compensator. The compensator automatically varies the volume output. When pressure approaches normal system pressure, the compensator begins to reduce the flow output of the pump. The pump is fully compensated (near zero flow) when normal system pressure is attained. When the pump is in this fully compensated condition, its internal bypass mechanism provides fluid circulation through the pump for cooling and lubrication. A relief valve is installed in the system as a safety backup.

An advantage of the open-center system over the closed-center system is that the continuous pressurization of the system is eliminated. Since the pressure is built up gradually after the selector valve is moved to an operating position, there is very little shock from pressure surges. This action provides a smoother operation of the actuating mechanisms. The operation is slower than the closed center system, in which the pressure is available the moment the selector valve is positioned. Since most aircraft applications require instantaneous operation, closed-center systems are the most widely used.

Power systems are designed to produce and maintain a given pressure. The pressure output of most of the Navy's high-performance aircraft is 3,000 psi. The hydraulic system, shown in figure 12-2, is an example of a representative 3,000-psi hydraulic power

system. The aircraft has three independent hydraulic power systems. The two primary systems are the flight hydraulic power system and the combined hydraulic power system. These systems are pressurized by two independent engine-driven hydraulic pumps on each engine. The auxiliary power system also operates on 3,000-psi pressure. It is pressurized by the hydraulic hand pump and/or the electric motor-driven hydraulic pump. The auxiliary power system is similar to the combined hydraulic power system. The primary difference is that the combined system supplies hydraulic pressure to utility hydraulic circuits and the flight controls.

The hydraulic control valves and actuators that operate the primary flight controls are of the tandem construction type. This design permits operation from either or both of the two power systems. With this arrangement, either engine can fail or be shut down without complete loss of hydraulic power to either system. The flight system reservoir supplies fluid to the two engine-driven flight system pumps. The combined system reservoir supplies fluid to the two engine-driven combined system pumps and to the auxiliary hydraulic power system. Both reservoirs are of the pressurized piston type. They are pressurized by engine bleed air during engine operations and by an external air (nitrogen) source during maintenance operations.

Hydraulic system pressure is indicated on the integrated hydraulic pressure indicator. This indicator displays the output pressure of the flight and combined hydraulic power systems. The flight hydraulic power system provides power for the operation of the rudder, stabilizer, and flaperons. It also provides power for operation of the automatic flight control system actuators, which are an integral part of the rudder and stabilizer control surface actuators. The flight hydraulic system also controls the automatic operation of the isolation valve. This valve is a part of the combined hydraulic system.

The combined hydraulic power system consists of two parallel circuits—one to power the primary systems and the other to power the secondary systems. The primary system consists of spin recovery, rudder, stabilizer flaperon, speed brakes, and electric ram air turbine systems. The secondary system consists of wing slats, wing flaps, wing fold, landing gear, arresting gear, wheel brakes, nosewheel steering, and the nose strut locking systems.

The isolation valve shuts off flow to the secondary systems during flight and limits the combined system's

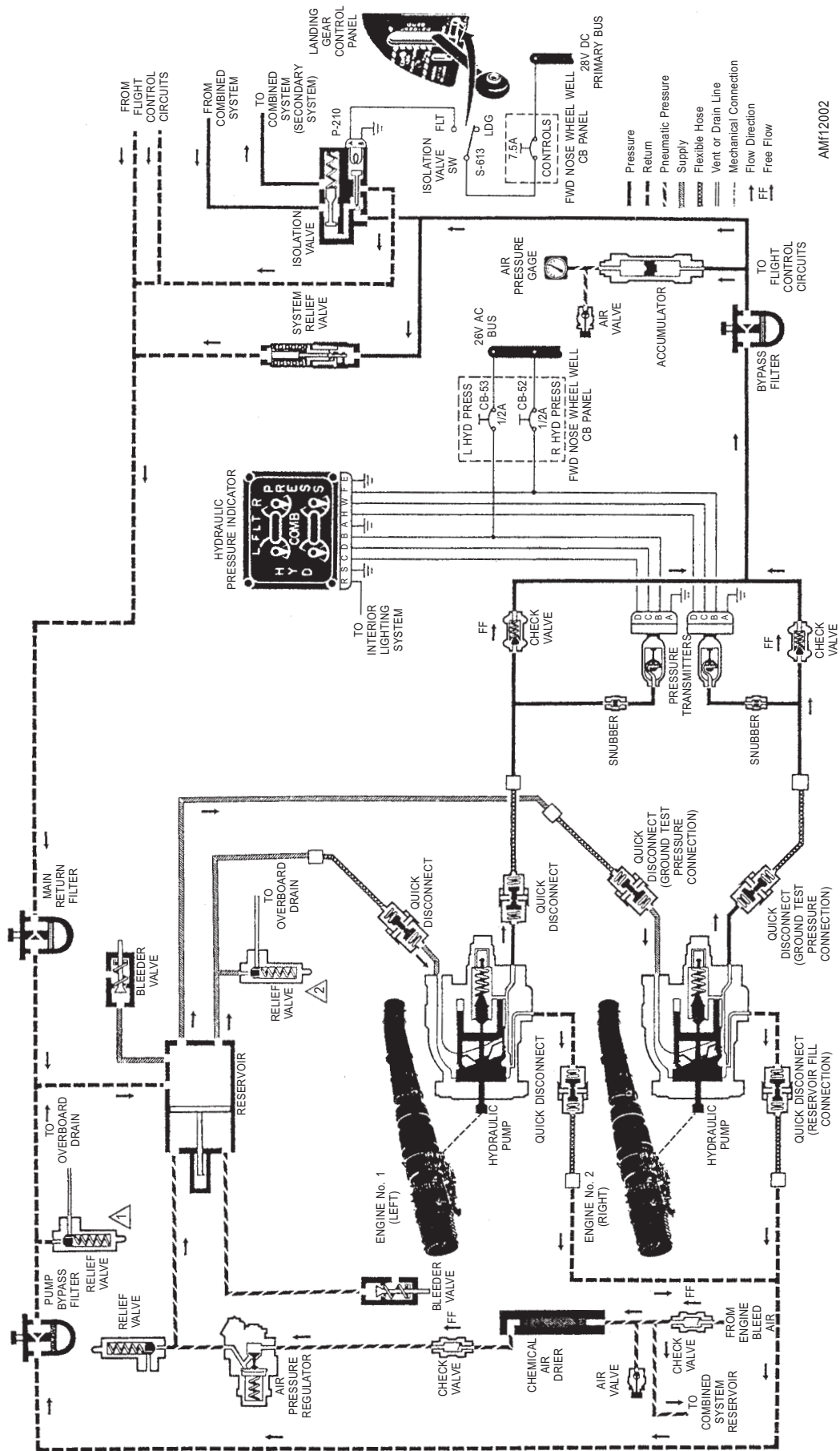

Figure 12-2.—Closed-center hydraulic system schematic.

pressure requirements to operation of the primary circuit. Operation of the isolation valve is both automatic and manual.

The reservoir pressurization system provides the reservoir with a differential pressure of 40 psi to prevent engine-driven pump cavitation. The pressure is maintained at 40 psi by the air regulator. In the event of regulator failure, the relief valve installed between the regulator and the reservoir prevents overpressurization. The relief valve opens at 50 psi. The chemical air drier removes excessive moisture from the bleed air. Dry, clean air is sent to the reservoir through the check valve, air regulator, and relief valve.

Two bleeder valves are installed in the flight and combined system reservoirs. One is found on the air side of the reservoir and the other on the fluid side. The air side valve permits the bleeding of air pressure during system maintenance. It allows the bleeding of any hydraulic fluid seepage past seals to the air side. The fluid side bleeder reduces excessive fluid level and bleeds air from the fluid side.

Quick-disconnect fittings in the hydraulic power systems permit easy pump or engine removal without loss of fluid to the system. The fittings connect ground hydraulic test stands for maintenance purposes. The pump disconnects should not be forced together against the backpressure of a pressurized reservoir or system. Forcing disconnects together may result in damaged seals in the male ends of the disconnects. When the disconnects do not slide in smoothly, they should be removed and checked for proper seating of the O-rings. Replace seals if they are damaged. The seal goes on top of the O-ring. When the disconnects are uncoupled, the ends not being used should be properly protected from dirt and other contamination. Use only approved metal closures.

EMERGENCY POWER SYSTEMS

According to the military specifications, which establish the requirements for aircraft hydraulic systems, all hydraulically operated systems considered essential to flight safety or landing must have provisions for emergency actuation. The specifications further state that these emergency systems may use hydraulic fluid, compressed gas, directed mechanical linkage, or gravity for their actuation.

Some aircraft use mechanical linkage or gravity in conjunction with pneumatic pressure for emergency actuation of landing gear and other actuating systems

where limited actuation is required. Most other essential hydraulically operated systems have emergency power systems that are powered by a hand pump, electric motor-driven pump, ram-air turbine-driven pump, or a pneumatic compressor.

On some aircraft, the hand pump is a part of the auxiliary hydraulic system and is not considered as part of the emergency power systems. The hand pump is used for ground operation of the canopy, extensible electronics platform, nose radome opening, and to recharge the brake accumulator. These systems may be operated by aircraft system pressure or, if the aircraft is shutdown, they may be powered by the auxiliary electric motor-driven hydraulic pump or the hand pump.

- Q12-1. A system that combines the use of hydraulics and pneumatics is known by what term?*
- Q12-2. Hydraulic flight control system design specifications require what total number of separate systems for operation of the primary flight controls?*
- Q12-3. What type of hydraulic system has fluid flow but no pressure in the system when the actuating mechanisms are idle?*
- Q12-4. What is the major difference between an open-center hydraulic system and a closed-center hydraulic system?*
- Q12-5. What is the advantage of the open-center hydraulic system over the closed-center hydraulic system?*
- Q12-6. The hydraulic control valves and actuators that operate the primary flight controls are of what type construction?*

HYDRAULIC COMPONENTS

LEARNING OBJECTIVE: Identify the various hydraulic system components. Recognize the procedures required for their maintenance.

Various types of hydraulic components make up a power system. The components discussed here are representative of those with which you will most likely be working. Values such as pressure, temperature, and instructional tolerances have been given to provide detail in the coverage.

When actually performing the maintenance procedures, you will find the exact location and make

up of the various hydraulic and pneumatic components will vary with the design of the hydraulic system. You should consult the current applicable technical publication for the latest information on items such as location, pressure, temperature, and tolerances.

RESERVOIRS

The reservoir is a tank in which an adequate supply of fluid for the system is stored. Fluid flows from the reservoir to the pump, where it is forced through the system and eventually returned to the reservoir.

The reservoir not only supplies the operating needs of the system, but it also replenishes fluid lost through leakage. Furthermore, the reservoir serves as an overflow basin for excess fluid forced out of the system by thermal expansion (the increase of fluid volume caused by temperature changes), the accumulators, and by piston and rod displacement. The reservoir also furnishes a place for the fluid to purge itself of air bubbles that may enter the system. Foreign matter picked up in the system may also be separated from the fluid in the reservoir, or as it flows through line filters.

Most nonpressurized reservoirs contain filters to maintain the hydraulic fluid in a clean state, free from foreign matter. They are usually located in filler necks and internally within the reservoir. The mesh-type filter (finger strainer), usually installed in the filler neck, removes foreign particles from fluid that is added to the reservoir. Internally installed filters clean the fluid as it returns to the reservoir from the system. This type of installation may have a bypass valve incorporated to allow fluid to bypass the filter if it becomes clogged. Some modern aircraft hydraulic reservoirs do not incorporate this feature. All reservoirs containing filters are designed to permit easy removal of the filter element for cleaning or replacement.

A reservoir instruction plate is usually attached to the reservoir, or it may be attached to the aircraft structure adjacent to the filler opening. Navy specifications designate the minimum information that must be contained on this plate. Figure 12-3 shows the reservoir instruction plate. Information on an instruction plate must include the following:

1. Simple and complete instructions for filling
2. Reservoir fluid capacity at full level
3. Full level indication
4. Refill level indication

5. Specification number and color of fluid
6. Position of operating cylinders during filling
7. System pressure (accumulator charged or discharged)
8. Instructions regarding air bleeding

Additional information may be added, when required, such as the following:

1. Additional full and refill levels under various conditions of system pressure
2. Safety precautions
3. Filter element servicing information
4. Total fluid capacity of the system

There are two classes of hydraulic reservoirs—class I and class II. Class I reservoirs are constructed in such a manner that the air and hydraulic fluid are not separated. Class II reservoirs are constructed in such a manner that the pressurizing agent and fluid chambers are separated. This is accomplished by installing a piston between the chambers.

Nonpressurized reservoirs are vented to the atmosphere so the reservoir can “breathe.” This is done to prevent a vacuum from being formed as the fluid level in the reservoir is lowered. The vent also makes it possible for air that has entered the system to find a means of escape.

The reservoir on aircraft designed for high-altitude flying is usually pressurized. Pressurizing assures a positive flow of fluid to the pump at high altitudes when low atmospheric pressures are encountered.

On some aircraft, the reservoir is pressurized by bleed air taken from the compressor section of the engine. On others, the reservoir may be pressurized by hydraulic system pressure.

Nonpressurized Reservoirs

Nonpressurized reservoirs are used in several transport, patrol, and utility aircraft. These aircraft are not designed for violent maneuvers; in some cases, they do not fly at high altitudes. Those aircraft that incorporate nonpressurized reservoirs and fly at high altitudes have the reservoirs installed within a pressurized area. High altitude in this situation means an altitude where atmospheric pressure is inadequate to maintain sufficient flow of fluid to the hydraulic pumps. Most nonpressurized reservoirs are constructed in a cylindrical shape. The outer housing

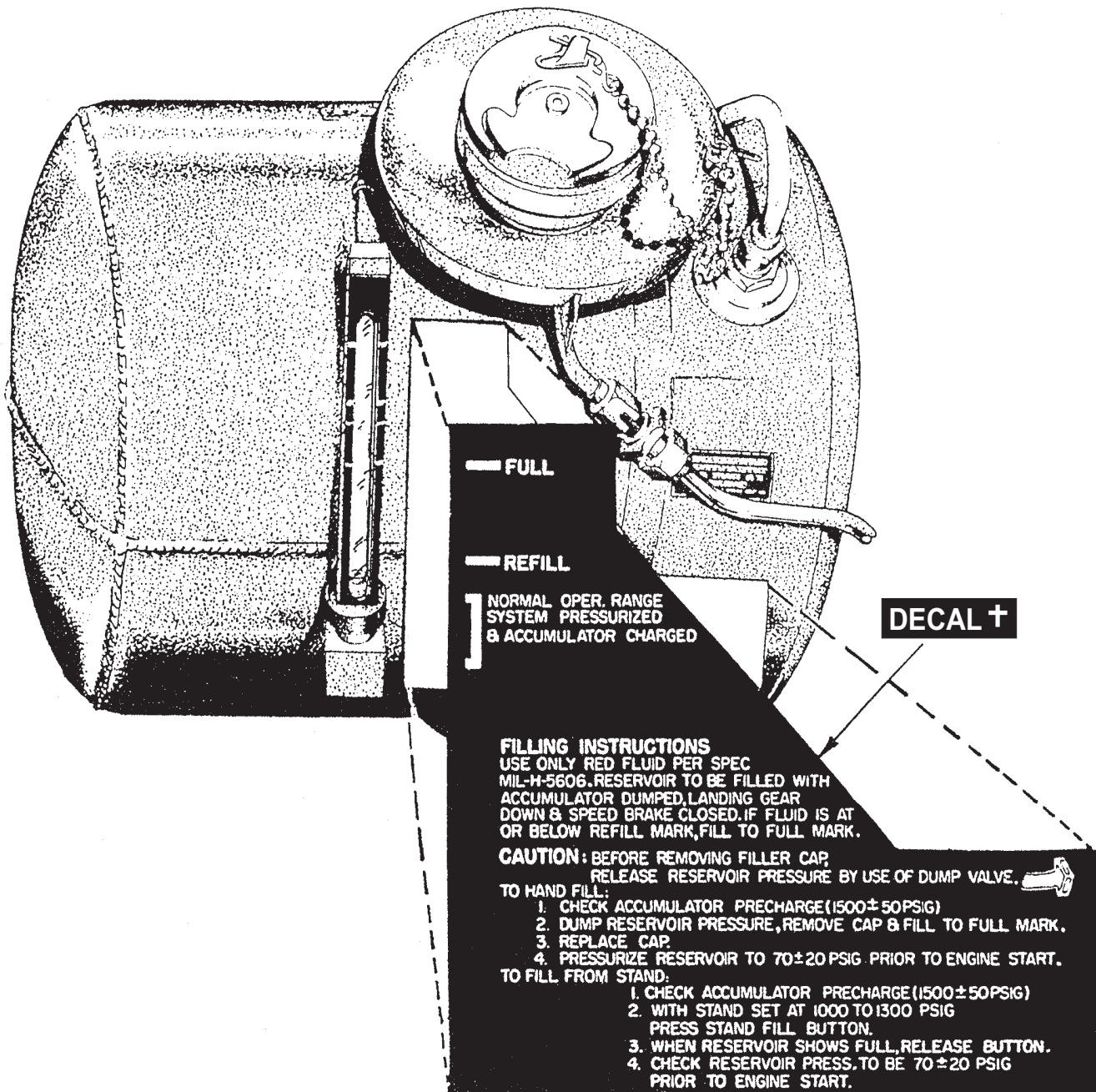

AMF12003

Figure 12-3.—Hydraulic reservoir instruction plate.

is manufactured from a strong corrosion-resistant metal.

Filter elements are normally installed internally within the reservoir to clean returning system hydraulic fluid. In some of the older aircraft, a filter bypass valve is incorporated to allow fluid to bypass the filter in the event the filter becomes clogged. Reservoirs serviced by pouring fluid directly into the reservoir have a filler strainer (finger strainer) assembly incorporated within the filler well to strain out impurities as the fluid enters the reservoir.

Generally, reservoirs described in the above paragraph use a visual gauge to indicate the fluid quantity. Gauges incorporated on or in the reservoir may be either a glass tube, a direct reading gauge, or a float-type rod, which is visible through a transparent dome. In some cases, the fluid quantity may also be read in the cockpit through the use of quantity transmitters.

A typical nonpressurized reservoir is shown in figure 12-4. This reservoir consists of a welded body and cover assembly clamped together. Gaskets are

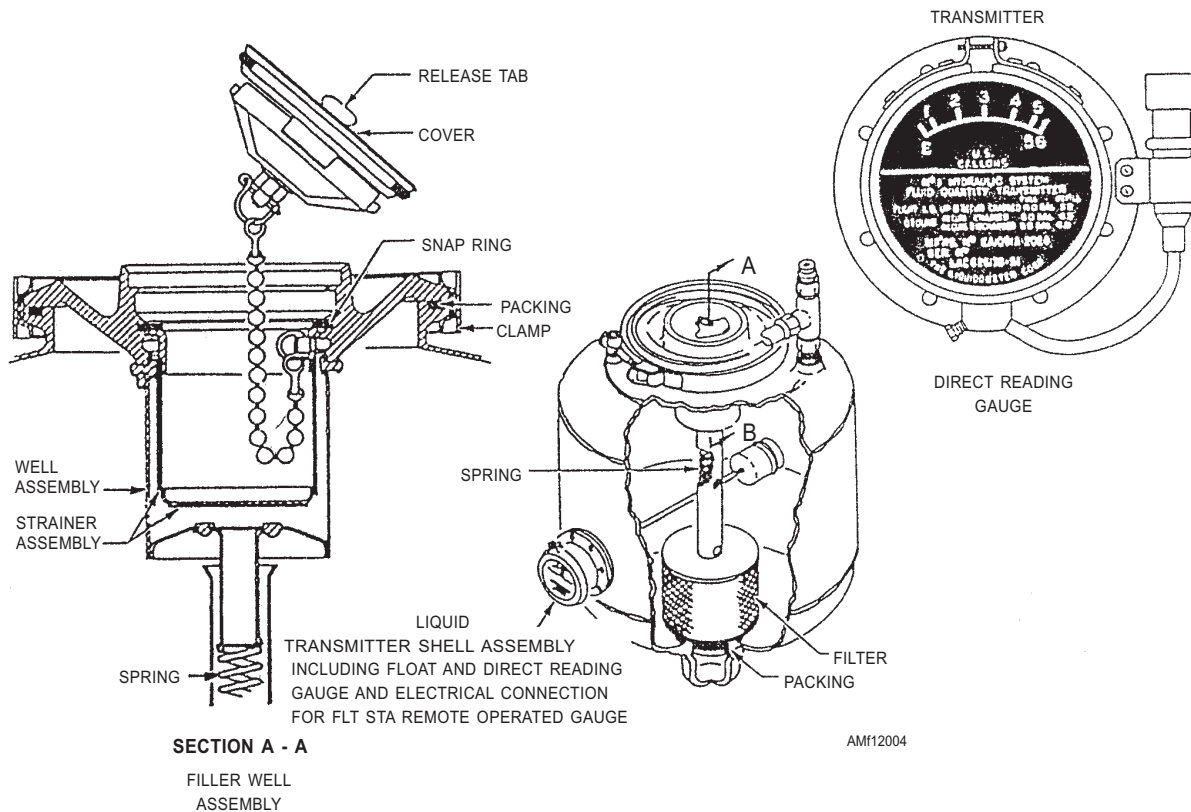

Figure 12-4.—Nonpressurized reservoir.

incorporated to seal against leakage between assemblies.

QUANTITY INDICATING GAUGE.—The reservoir fluid quantity is indicated through a mechanically operated float and arm (liquidometer) type of unit. The quantity gauge is mounted directly on the side of the reservoir. As shown in figure 12-4, the float and arm unit extends into the reservoir. The shell of the liquidometer provides a glass window over a pointer and dial, with the pointer mechanically linked to the float arm. As the float arm moves to correspond to the fluid level, the pointer, through mechanical linkage, moves to indicate the quantity available. This provides a direct reading sight gauge at the reservoir.

This same float movement actuates the potentiometer wiper arm of an integral transmitter potentiometer. The remote indicating circuit is energized, and a duplicate indication of the reservoir fluid quantity may be seen in the cockpit on a remote gauge.

RESERVOIR PRESSURE AND VACUUM RELIEF VALVE.—Although the reservoir shown in figure 12-4 is classified as a nonpressurized type, it has a sufficient amount of pressurization to ensure a positive flow of fluid to the pump suction ports. The pressurization is derived from thermal expansion of

fluid and the return of fluid to the reservoir from the main system.

Most reservoirs of this type are vented directly to the atmosphere or cabin with only a check valve and filter to control the outside air source. The reservoir system includes a pressure and vacuum relief valve. The valve, as shown in figure 12-5, has two reservoir ports, and it is connected between and serves both main system reservoirs. The purpose of the valve is to maintain a differential pressure range between the reservoir and cabin.

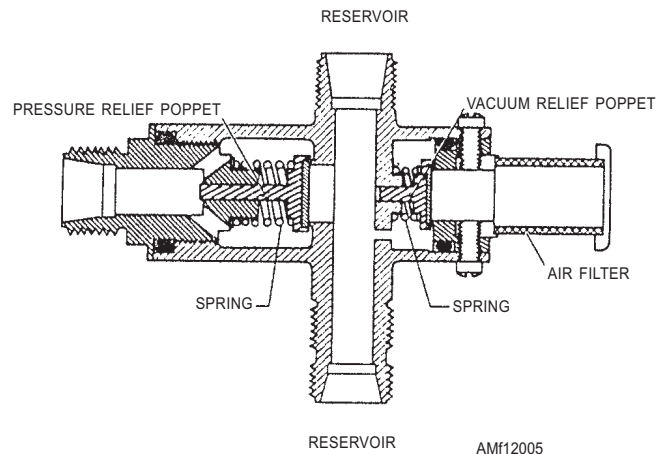
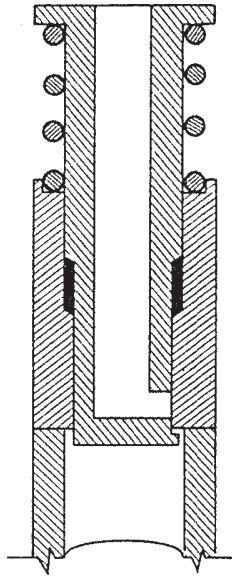

Figure 12-5.—Pressure and vacuum relief valve.

RESERVOIR MANUAL AIR BLEED (VENT) VALVE.—A vent valve is provided to vent the reservoir. This valve is connected to the reservoir vent line to allow depressurization of the reservoir.

The valve is actuated prior to servicing the reservoir to prevent fluid from being blown out of the filler as the cap is being removed. Figure 12-6 shows a



AMf12006

Figure 12-6.—Manual air bleed valve.

full sectional view of a manual air bleed valve. Pressing the slide valve opens a passage to vent the reservoir.

Air-Pressurized Reservoirs

Air-pressurized reservoirs are currently used in many high-performance naval aircraft. Figure 12-7 shows a hydraulic power system with an air-pressurized reservoir incorporated. This system is similar to the one found on many aircraft; however, for clarification in the discussion of the operation of the system, we have deleted some components between the reservoir and the pump.

The reservoir is cylindrical in shape and has a piston installed internally to separate the air and fluid chambers. The piston rod end protrudes through the reservoir end cap and indicates the fluid quantity. The quantity indication may be seen by inspecting the distance the piston rod protrudes from the reservoir end cap. The reservoir has threaded openings for the connection of fittings and components. The schematic shown in figure 12-7 shows several components installed in lines leading to and from the reservoir; however, this may not be the case in the actual installation. The air relief valve, bleeder valve, etc., may be installed directly on the reservoir.

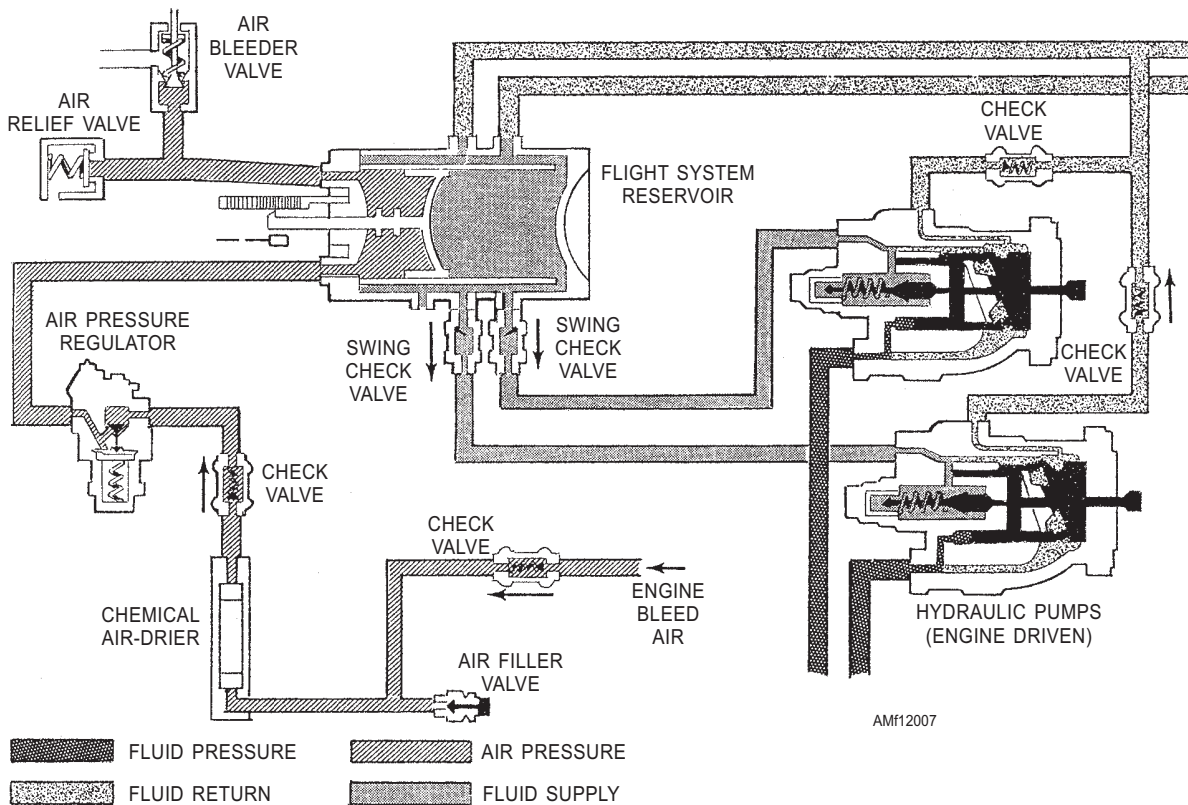

AMf12007

Figure 12-7.—Air-pressurized reservoir and components.

Because the reservoir is pressurized, it can normally be installed at any attitude and still maintain a positive flow of fluid to the pump.

CHEMICAL AIR DRIER.—Chemical air driers are installed in air systems to absorb moisture that may collect from air entering the system. The main parts of the air drier, shown in figure 12-8, are the housing, desiccant cartridge, filter (porous bronze), and the spring. To ensure proper filtering, the air must pass through the air drier in the proper direction. The correct direction of flow is indicated by an arrow and the word *flow* printed on the side of the cartridge.

Preventive maintenance of this component consists of replacing the cartridge when it becomes saturated. Maintenance should be accomplished in accordance with instructions provided in the applicable maintenance instruction manual (MIM).

AIR PRESSURE REGULATORS.—Air pressure used in pressurizing hydraulic reservoirs must be controlled within safe limits. Specific pressure requirements vary between aircraft. In some aircraft, the air pressure is controlled by an air pressure regulator (fig. 12-9). This regulator normally maintains 40 psi pressure in the reservoir. It also incorporates a relief valve to relieve excessive pressure and a differential valve to allow equalization of pressures between ambient (outside) air and reservoir air pressures.

AIR RELIEF VALVE.—An air relief valve is normally incorporated in the air portion of the hydraulic power system to relieve excessive air pressure entering the reservoir due to a malfunctioning

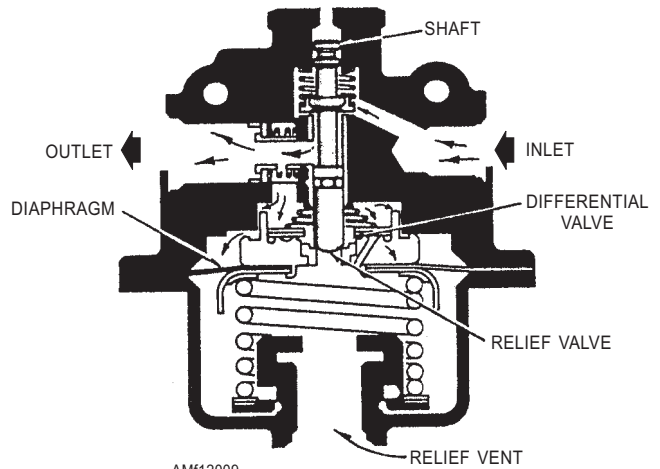

AMf12009
Figure 12-9.—Air pressure regulator.

air pressure regulator. The relief valve shown in figure 12-10 is cylindrical in shape and consists of a housing, poppet, spring, and adjusting screw. This valve may be mounted directly to the reservoir or in a line leading from the reservoir, depending on the aircraft system design.

During operation, air pressure enters the inlet port and contacts the poppet surface. When system air pressure increases to 50 psi, the poppet is forced off its seat, which allows excessive air pressure to be exhausted to the atmosphere. When system pressure is lowered to 49 psi, the poppet spring tension overcomes system pressure and reseats the poppet, thus closing the valve.

Maintenance of the valve usually includes the replacement of all seals and the adjustment of its controlling pressures. This valve is designed to relieve

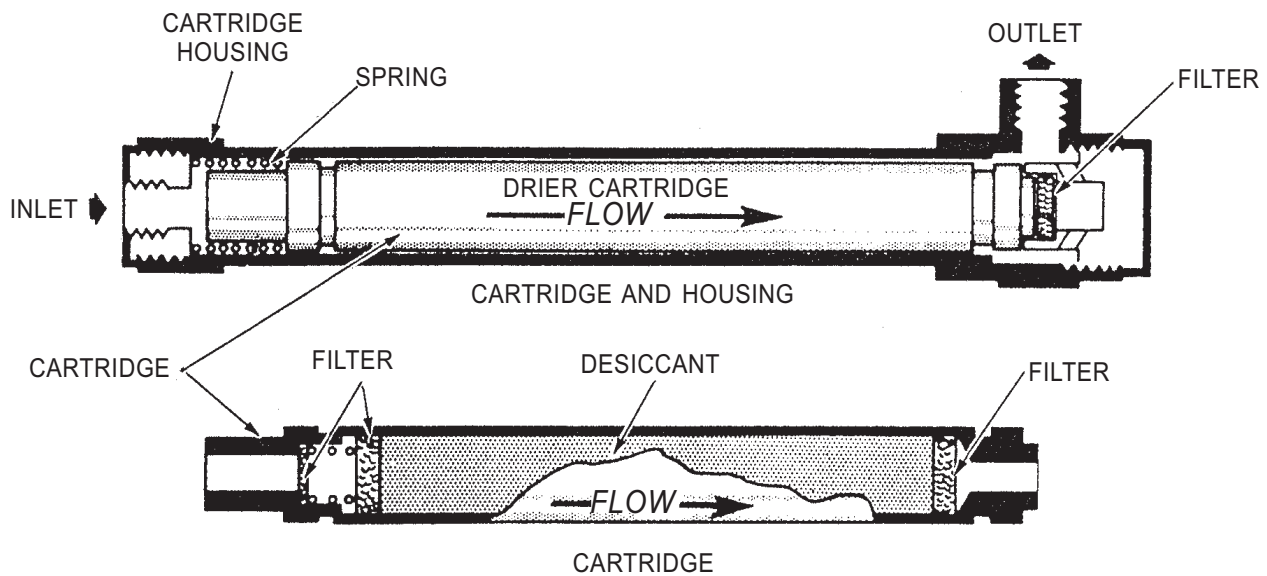

AMf12008
Figure 12-8.—Chemical air drier.

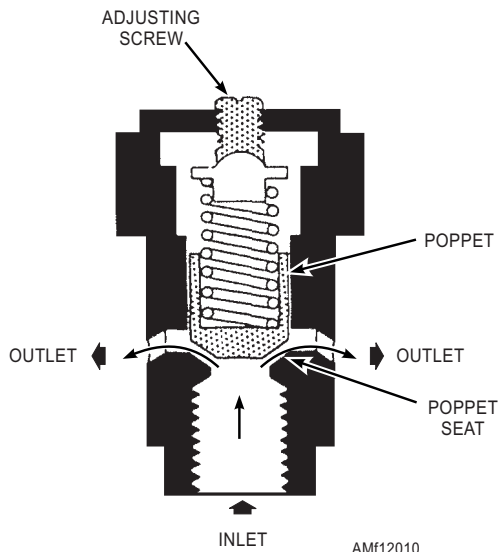

Figure 12-10.—Air relief valve.

at a cracking (just open) pressure of 50 psi; the reseating pressure is 49 psi. The valve will operate at full flow when the pressure reaches 60 psi.

All pressure adjustments of relief valves must be performed on a test bench. You can control valve pressures by adjusting the adjusting screw on the valve until the proper settings are obtained.

AIR BLEEDER VALVE.—During hydraulic system maintenance, it is necessary to relieve reservoir air pressure to assist in the installation and removal of components, lines, etc. An air bleeder valve is incorporated within the reservoir air system to avoid disassembly of lines or units. A similar valve may be incorporated in reservoir return lines to provide a means for bleeding air from returning fluid.

This type of valve is small in size and has a push button installed in the outer case. Figure 12-11 shows a full view schematic drawing of a bleeder valve. The valve is made up of a body, spring, poppet, and push button. When the bleeder valve push button is depressed, pressurized air from the reservoir flows through the valve to an overboard vent, until the air pressure is depleted or the button is released. When the button is released, the internal spring causes the poppet to return to its seat. In case of malfunction, this type of valve is replaced with a new valve.

SYSTEM OPERATION.—During normal operation, the pressurizing air source comes from engine bleed air. See figure 12-7. This bleed air is routed through a poppet-type, one-way check valve to the chemical drier. The chemical drier conditions the air by absorbing its moisture. Conditioned air is then routed through a poppet check valve to the system air

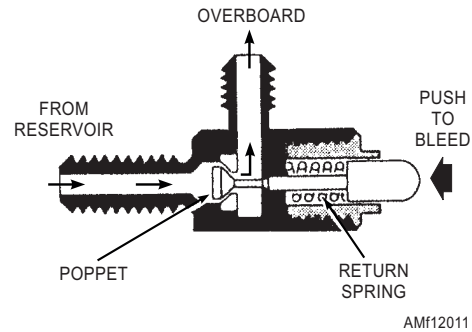

Figure 12-11.—Air bleeder valve.

pressure regulator. The regulator decreases engine bleed air pressure to a desired working pressure.

As air pressure leaves the regulator, it enters the reservoir and acts on its piston, which, in turn, transmits force to the fluid. If malfunction of the regulator causes excessive reservoir air pressure, an air relief valve will open at a preset pressure and exhaust excessive air overboard. Fluid under pressure in the reservoir provides a positive flow of fluid through a one-way check valve to the suction port of the hydraulic pump, thus preventing pump cavitation or starvation.

Fluid-Pressurized Reservoirs

Some aircraft hydraulic systems use fluid pressure for pressurizing the reservoir. The reservoir shown in figure 12-12 is a fluid-pressurized reservoir. This reservoir is divided into two chambers by a floating piston. The floating piston is forced downward in the reservoir by a compression spring within the pressurizing cylinder and by system pressure entering the pressurizing port of the cylinder.

The pressurizing port is connected directly to the pressure line. When the system is pressurized, pressure enters the pressure port, thus pressurizing the reservoir. This pressurizes the pump suction line and the reservoir return line to the same pressure. Positive pressure prevents pump starvation.

The reservoir shown in figure 12-12 has five ports—pump suction, return, pressurizing, overboard drain, and bleed port. Fluid is supplied to the pump through the pump suction port. Fluid returns to the reservoir from the system through the return port. Pressure from the pump enters the pressurizing cylinder in the top of the reservoir through the pressurizing port. The overboard drain port is for the purpose of draining the reservoir, when necessary, while performing maintenance. The bleed port is used as an aid in servicing the reservoir.

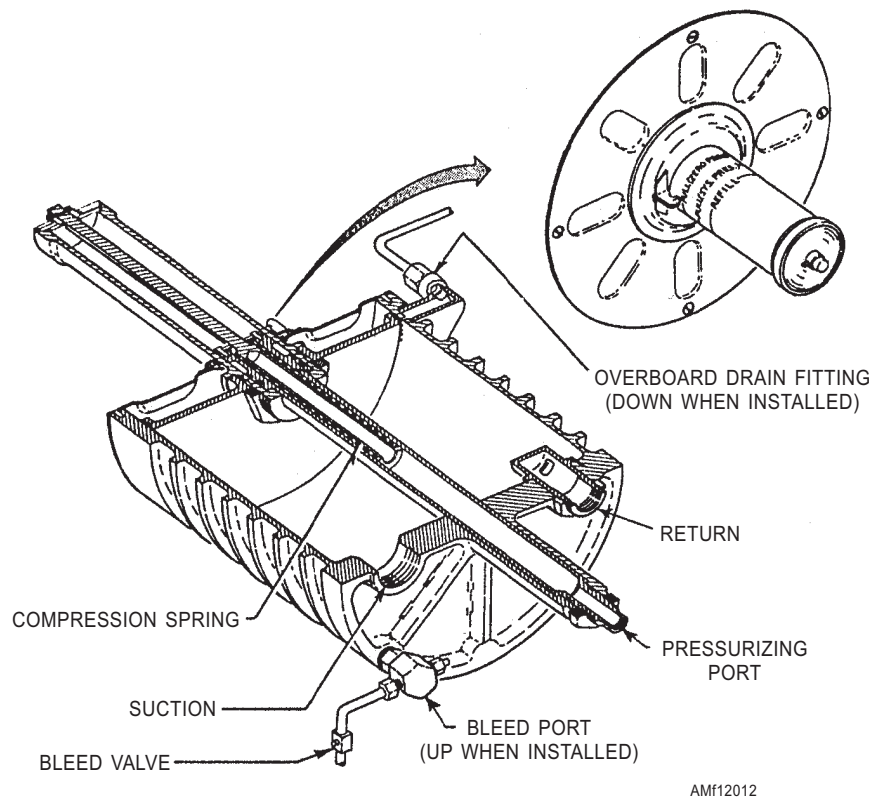

Figure 12-12.—Typical fluid-pressurized reservoir.

When you service a system equipped with this type of reservoir, place a container under the bleed drain port. The fluid should then be pumped into the reservoir until air-free fluid flows through the bleed drain port.

The reservoir fluid level is indicated by the markings on the part of the pressurizing cylinder that moves through the reservoir dust cover assembly. See figure 12-12. There are three fluid level markings indicated on the cover: full at zero system pressure (FULL ZERO PRESS), full when system is pressurized (FULL SYS PRESS), and REFILL. When the system is unpressurized and the pointer on the reservoir lies between the two FULL marks, a marginal reservoir fluid level is indicated. When the system is pressurized and the pointer lies between REFILL and FULL SYS PRESS, a marginal reservoir fluid level is also indicated.

PUMPS

All aircraft hydraulic systems have one or more power-driven pumps and may have a hand pump as an additional source of power. Power-driven pumps are the primary source of energy, and may be either engine-driven or electric-motor driven. As a general rule, motor-driven pumps are installed for use in

emergencies; that is, for operation of actuating units when the engine-driven pump is inoperative. Hand pumps are generally installed for testing purposes as well as for use in emergencies.

Hand Pumps

Hand pumps are used in hydraulic systems to supply fluid under pressure to subsystems, such as the landing gear, flaps, canopy, and bomb-bay doors, and to charge brake accumulators. Systems using hand pumps are classified as emergency systems. Most of these systems may be used effectively during preventive maintenance.

Double-action type of hand pumps are used in hydraulic systems. Double action means that a flow of fluid is created on each stroke of the pump handle instead of every other stroke, as in the single-action type. There are several versions of the double-action hand pump, but all use the reciprocating piston principle, and operation is similar to the one shown in figure 12-13.

This pump consists of a cylinder, a piston containing a built-in check valve (A), a piston rod, an operating handle, and a check valve (B) at the inlet port. When the piston is moved to the left in the

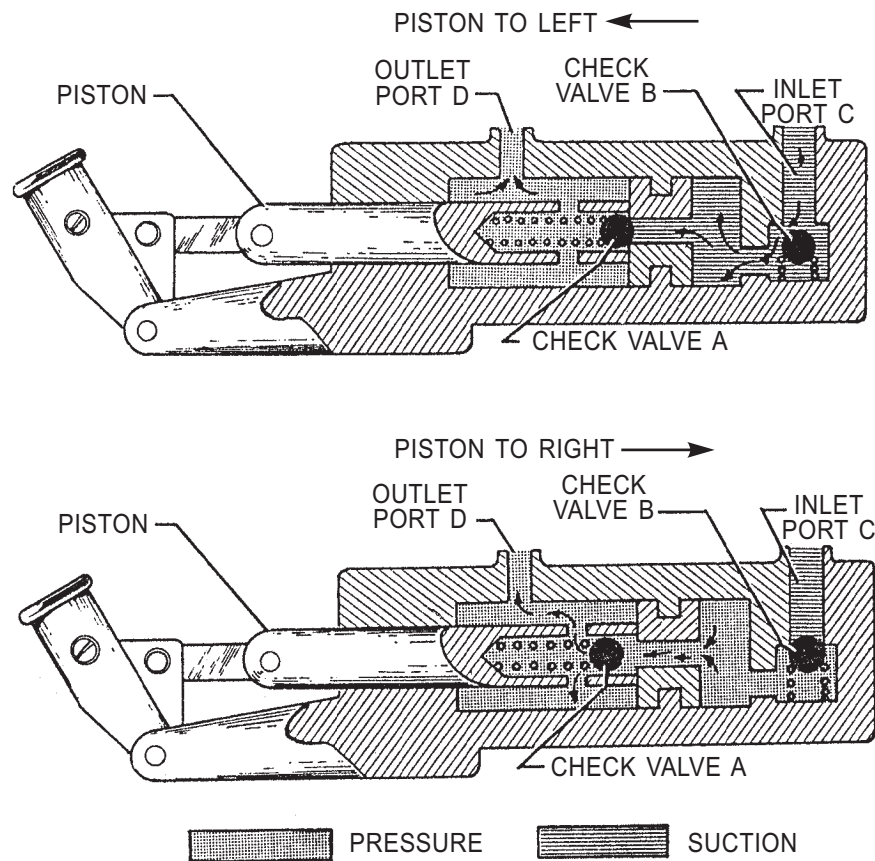

Figure 12-13.—Double-action hydraulic hand pump.

illustration, check valve (A) closes and check valve (B) opens.

Fluid from the reservoir then flows into the cylinder through inlet port (C). When the piston is moved to the right, check valve (B) closes. The pressure created in the fluid then opens check valve (A), and fluid is admitted behind the piston. Because of the space occupied by the piston rod, there is room for only part of the fluid; therefore, the remainder is forced out port (D) into the pressure line. If the piston is again moved to the left, check valve (A) again closes. The fluid behind the piston is then forced through outlet port (D). At the same time, fluid from the reservoir flows into the cylinder through check valve (B). Thus, a pressure stroke is produced with each stroke of the pump handle.

Hand pumps are examined frequently for leakage, general condition, and efficiency in operation. To check the operation of a hand pump, the following procedure is recommended:

1. Connect a direct-reading hydraulic pressure gauge into the emergency hand pump pressure line.
2. Insert and lock the hand pump handle in the pump actuating socket.

3. Select an appropriate subsystem to operate, and place its selector valve in an operating position.

4. Actuate the hand pump handle until the unit being operated has completed its movement. Check the pressure gauge for a drop in system pressure.

NOTE: Air in emergency systems will cause the pump handle to spring rapidly to the other end of the stroke.

5. If a pressure drop is indicated, check the system for leakage before removing the pump for repair or replacement.

6. Observe the hand pump handle for piston creep, which indicates that the pump should be removed for repair or replacement.

Removal, replacement, and operational check of hand pumps should correspond to the procedures recommended in the specific MIM.

Power-Driven Pumps

Power pumps are generally driven by the aircraft engine, but may also be electric-motor driven. Power pumps are classified according to the type of pumping action used, and may be either the gear type or piston

type. Power pumps may be further classified as constant displacement or variable displacement.

A constant displacement pump is one that displaces or delivers a constant fluid output for any rotational speed. For example, a pump might be designed to deliver 3 gallons of fluid per minute at a speed of 2,800 revolutions per minute. As long as it runs at that speed, it will continue to deliver at that rate, regardless of the pressure in the system. For this reason, when the constant displacement pump is used in a system, a pressure regulator or unloading valve must also be incorporated. The pressure regulator valve will maintain a set pressure in the system by diverting excess pump flow back to the reservoir. The unloading valve will divert all pump flow back to the reservoir when the preset system pressure is reached. This condition remains in effect until further demand is placed on the system.

A variable displacement pump has a fluid output that varies to meet the demand of the system. For example, a pump might be designed to maintain system pressure at 3,000 psi by varying its fluid output from 0 to 7 gallons per minute. When this type of pump is used, no external pressure regulator or unloading valve is needed. This function is incorporated in the pump and controls the pumping action by maintaining a variable volume, at near constant pressure, to meet the hydraulic system demands.

GEAR-TYPE PUMP.—A gear-type pump consists of two meshed gears that revolve in a housing (fig. 12-14). The drive gear in the installation is turned by a drive shaft that engages an electric motor. The clearance between the gear teeth as they mesh and between the teeth and pump housing is very small.

The inlet port is connected to the reservoir line, and the outlet port is connected to the pressure line. In the illustration, the drive gear is turning in a counterclockwise direction, and the driven (idle) gear is turning in a clockwise direction. As the teeth pass the inlet port, fluid is trapped between the teeth and the housing. This fluid is carried around the housing to the outlet port. As the teeth mesh again, the fluid between the teeth is displaced into the outlet port. This action produces a positive flow of fluid under pressure into the pressure line. A shear pin or shear section that will break under excessive loads is incorporated in the drive shaft. This is to protect the engine accessory drive if pump failure is caused by excessive load or jamming of parts.

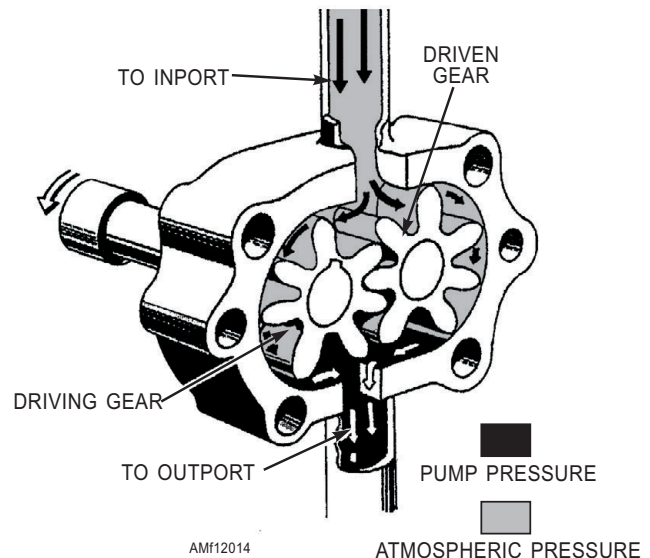

Figure 12-14.—Gear-type power pump.

All gear-type pumps are constant displacement pumps. These pumps are usually driven by a dc wound electric motor. For those aircraft using batteries, the pump may be used to build up hydraulic pressure for the brake system during towing operation.

Maintenance of a pump at the organizational level consists of replacement of the complete assembly. The motor and pump may be ordered separately; however, this is normally done by intermediate- and depot-level maintenance only.

Removal and installation procedures are found in the applicable MIM. The following removal procedures are typical examples.

1. Relieve reservoir pressure.
2. Pull the pump circuit breaker and place a warning card, DO NOT OPERATE, on the pump switch.
3. Disconnect the pump motor electrical connection at the motor.
4. Drain the pump reservoir or cap the reservoir suction line.
5. Disconnect the drain line at the pump.
6. Loosen the pressure and suction lines “B” nuts.
7. Remove the mounting screws/bolts that secure the pump assembly to the aircraft structure.
8. Disconnect completely the pressure and reservoir suction lines at the pump.
9. Cap all open lines, and lift the pump assembly out of the aircraft.

The following installation procedures are typical examples:

1. Place the pump on the aircraft structure mounting pad. Connect the pressure and suction lines to the pump ports and tighten the “B” nuts fingertight.
2. Align and install the mounting screws/bolts.
3. Tighten the “B” nuts to the correct torque values.
4. Attach the electrical connection to the motor.
5. Service the reservoir to the proper level.
6. Perform operational check according to the applicable MIM.

NOTE: Prior to the installation of hydraulic units, the preservation fluid must be drained and the unit flushed with clean hydraulic fluid.

PISTON-TYPE PUMP (CONSTANT DISPLACEMENT).—Piston-type constant displacement pumps consist of a circular cylinder block with either seven or nine equally spaced pistons. Figure 12-15 is a partial cutaway view of a seven-piston pump manufactured by Vickers, Incorporated.

The main parts of the pump are the drive shaft, pistons, cylinder block, and valve plate. There are two ports in the valve plate. These ports connect directly to openings in the face of the cylinder block. Hydraulic fluid is sucked in one port and forced out the other port by the reciprocating (back-and-forth) motion of the pistons.

There is a fill port in the top of the cylinder housing. This opening is normally kept plugged, but it can be opened for testing the pressure in the housing or case. When you install a new pump or newly repaired

one, this plug must be removed and the housing filled with fluid before the pump is operated. There is a drain port in the mounting flange to drain away any leakage from the drive shaft oil seal.

When the drive shaft is rotated, it rotates the pistons and cylinder block with it. The offset position of the cylinder block causes the pistons to move back and forth in the cylinder block while the shaft, pistons, and cylinder block rotate together. As the pistons move back and forth in the cylinder block, they draw the fluid in one port and force it out the other. This action creates a steady, nonpulsating flow of fluid. Certain models of this pump are capable of developing up to 3,000 psi working pressure.

Constant displacement pumps of this series are designed so they can be driven in either direction. The direction of rotation of the pump must coincide with the engine accessory section. The pump rotation can be determined by referring to an arrow on the pump housing adjacent to the valve plate. The only change necessary when changing the direction of rotation of the pump is to rotate the valve plate 180 degrees.

Before installation, the pump mounting flange and shim, if used, must be wiped clean. The pump must be primed by filling the housing with hydraulic fluid through the fill port. The exposed drive shaft spline should be lubricated. To ensure internal cleanliness, the shipping plugs should not be removed until the lines are ready for attachment.

Normally, for repair, the pump should be shipped to an intermediate-level activity; however, replacement of packings and gaskets can be accomplished in the field. To prevent damage in the event of the pump binding, a shear section is

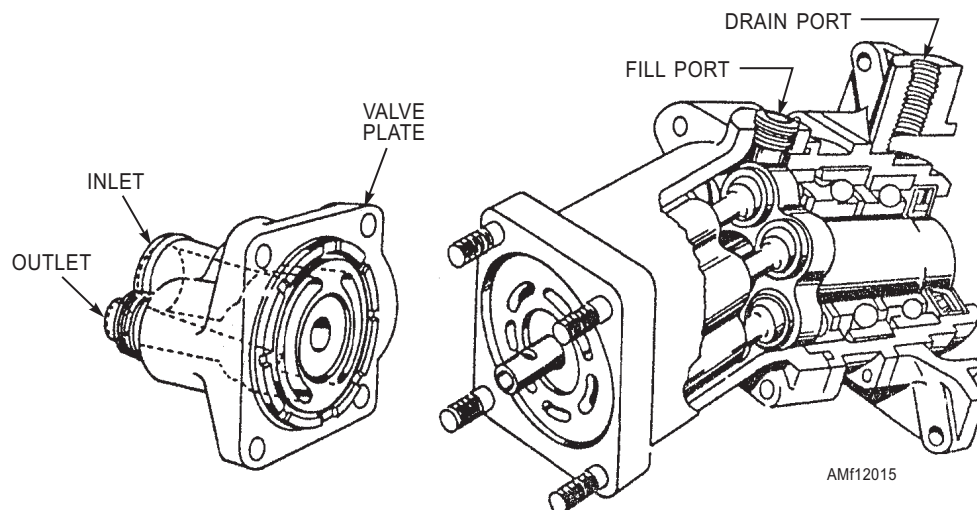

Figure 12-15.—Partial cutaway view of piston-type pump.

incorporated in the drive shaft coupling. The coupling may be replaced if the cause of the shearing is known and has been remedied. Immediately after removal, the pump housing should be filled two-thirds full with hydraulic fluid; the drive shaft couplings should be suitably protected by a wood block; and the ports securely plugged to prevent the entrance of foreign matter.

PISTON-TYPE PUMPS (STRATOPOWER VARIABLE DISPLACEMENT).—There are several models of the Stratopower variable displacement pump currently used on naval aircraft; however, all are similar in principle of operation. The pump described here is a Model 65WB06006, rated at 3,000 psi and capable of delivering 13 gallons of fluid per minute at 3,800 rpm.

Pressure regulation and flow control are accomplished internally, automatically adjusting pump delivery to meet the system demands.

Flow cutoff begins at approximately 2,850 psi, and it reaches zero (unloads) at 3,000 psi. When the pump is operating in the unloaded condition, the bypass system provides circulation of fluid internally for cooling and lubrication of the pump.

The pump has three ports—the suction port, the discharge port, and the drain or bypass port. The latter port is connected to the reservoir return line. The pump

is driven from the engine accessory drive by a splined drive coupling. A shear section is provided in the pump drive shaft to prevent damage from overload. Figure 12-16 shows the internal features of the pump.

Four major functions are performed by the internal parts of the pump. These functions are mechanical drive, fluid displacement, pressure control, and bypass.

Mechanical Drive Mechanism.—The mechanical drive mechanism is shown in figure 12-17. Piston motion is caused by the drive cam displacing each piston the full height of the drive cam each revolution of the drive shaft. By coupling the ring of pistons with a nutating (wobble) plate supported by a fixed center pivot, the pistons are held in constant contact with the cam face. As the drive cam depresses one side of the nutating plate (as pistons are advanced), the other side of the nutating plate is withdrawn an equal amount, moving the pistons with it. The two creep plates are provided to decrease wear on the revolving cam.

Fluid Displacement.—A schematic diagram of the displacement of fluid is shown in figure 12-18. Fluid is displaced by axial motion of the pistons. As each piston advances in its respective cylinder block bore, pressure opens the check spring and a quantity of fluid is forced past. Combined back pressure and

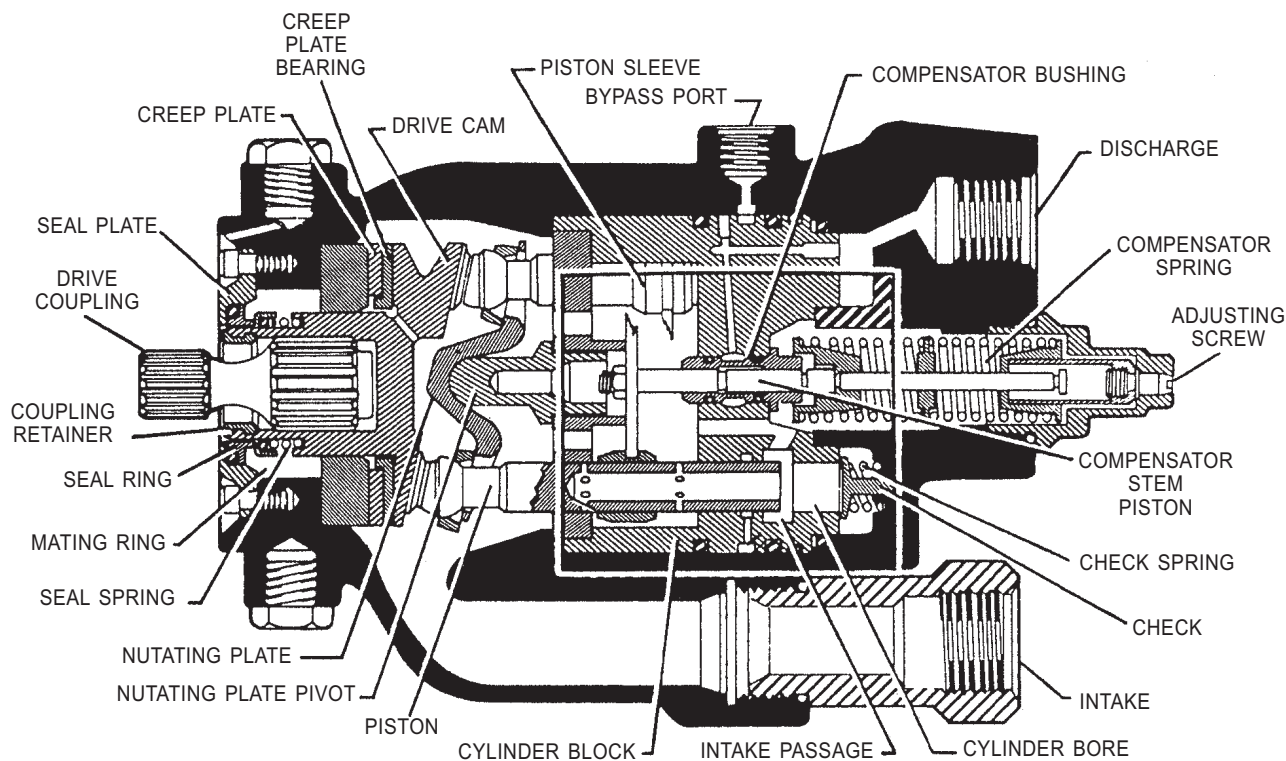

Figure 12-16.—Internal features of the Stratopower pump.

AMF12016

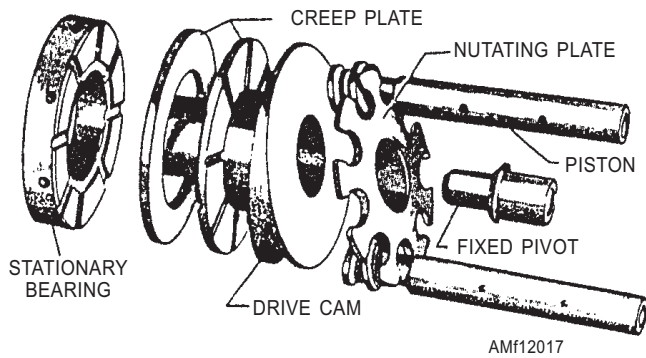

Figure 12-17.—Mechanical drive.

check spring pressure closes the check spring when piston bypass ports align with the cylinder block bypass passage. The partial vacuum occurring in the cylinder during the piston return causes reservoir fluid to flow from the intake loading groove into the cylinder.

Pressure Control.—A schematic diagram of the pressure control mechanism is shown in figure 12-19. Pressure is bled through the control orifice into the pressure compensator cylinder, where it moves the compensator piston against the force of the calibrated control (compensator) spring. This motion, transmitted by a direct mechanical linkage, moves sleeves axially on the piston, thereby varying the time during which relief holes are covered during each stroke.

Fluid flows through the hollow pistons during the forward stroke and escapes out the relief holes until they are covered by the piston sleeves. The effective piston stroke (delivery) is controlled by the piston sleeve position. During nonflow requirements, only enough fluid is pumped to maintain system pressure against leakage.

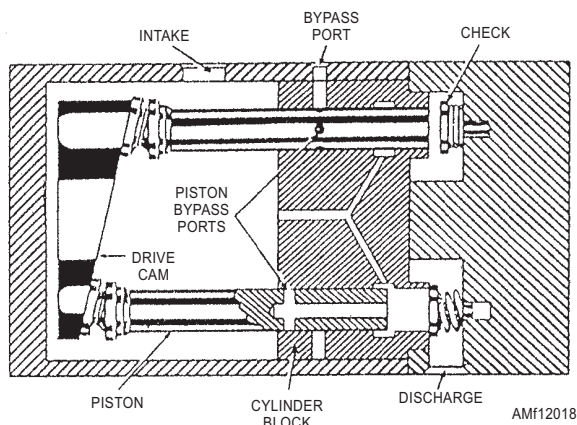

Figure 12-18.—Fluid displacement.

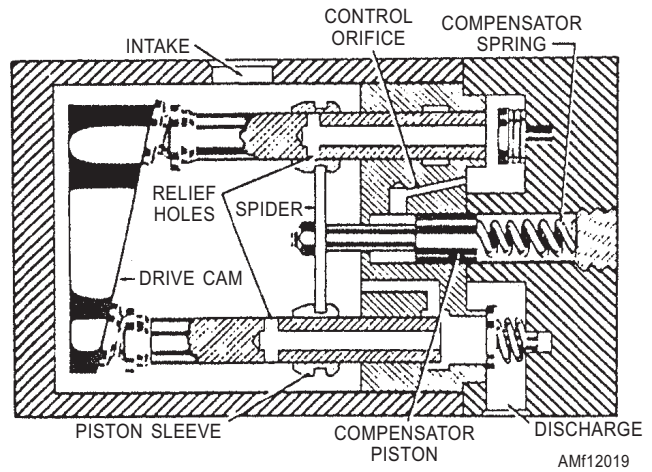

Figure 12-19.—Pressure control mechanism.

During normal pump operation, three conditions may exist—full flow, partial flow, and zero or nonflow. During full flow operation (fig. 12-20), fluid enters the intake port and is discharged to the high-pressure side past the pump checks by the reciprocating action of the pistons. Piston sleeves cover the relief holes for the entire pressure stroke.

During partial flow, system pressure is sufficient (as bled through the orifice) to move the compensator stem against the compensator spring force.

If system pressure continues to build up, as under nonflow conditions, the stem will be moved further until the relief holes are uncovered for practically the entire piston stroke. Relief holes will be covered only for the stroke necessary to maintain pressure against system leakage and to produce adequate bypass flow.

Bypass.—The bypass system is provided to supply self-lubrication, particularly when the pump is in nonflow operation. The ring of bypass holes in the pistons are aligned with the bypass passage each time a piston reaches the very end of its forward travel. This pumps a small quantity of fluid out the bypass passage, back to the supply reservoir, and provides a constant changing of the fluid in the pump. The bypass is designed to pump against a considerable back pressure for use with pressurized reservoirs.

Maintenance.—Line maintenance of the Stratopower pump is limited to operational checks, and checking for leaks and loose fittings. Malfunctioning pumps should be removed and replaced.

In removing a pump, always maintain its alignment until the drive shaft is fully withdrawn from the driving element. Never pick up or carry a pump by the drive shaft extension.

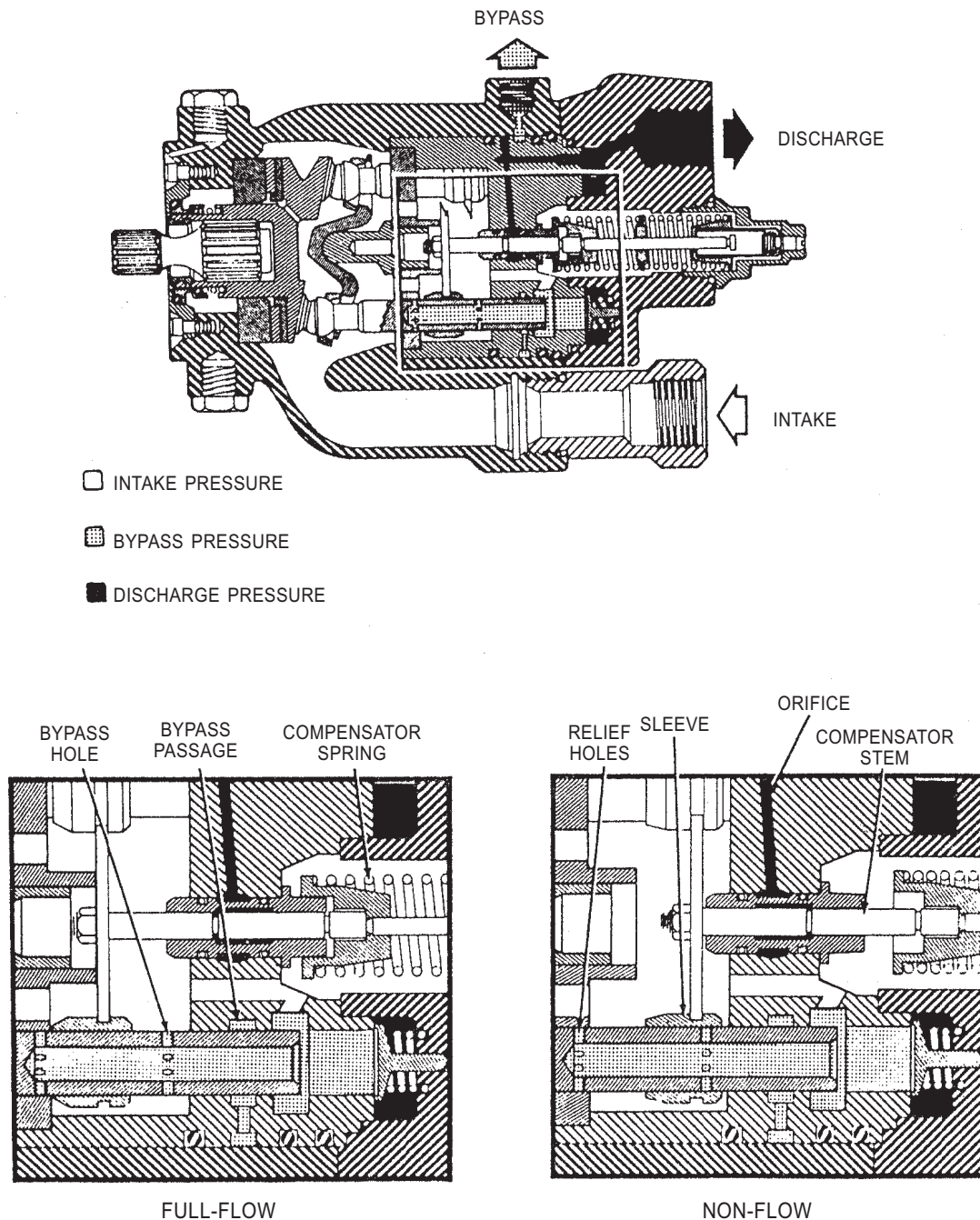

Figure 12-20.—Fluid flow.

AMf12020

Before installing a pump, the pump and its attached hose assemblies must be primed (filled with fluid). During installation, the pump must be continuously supported with its shaft parallel to the mounting studs, and the splines must mesh with the driving element.

If the pump drive shaft does not engage the driving element, preventing the pump from sliding into place, the drive shaft should be manually rotated until the two splined drive shafts mate.

PISTON-TYPE PUMP (VICKERS ELECTRIC MOTOR-DRIVEN VARIABLE DISPLACEMENT).

—This type of pump is used in some of the Navy's most modern aircraft. Motor-driven variable displacement pumps have several advantages over the engine-driven models. Some of these advantages are as follows:

1. Ease of installation and removal due to the accessibility of the component.
2. Constant speed of the drive shaft.

- Eliminates the need of using a test stand to drop check the landing gear and perform operational checks of other actuating systems.

NOTE: Hydraulic test stands are seldom used on aircraft that incorporate this type of pump because foreign particles could be transferred from the test stand to the aircraft, thus contaminating the hydraulic system.

- The pump assembly contains an internal centrifugal boost pump, which provides a positive fluid pressure at the suction port of the variable displacement pump.

The only disadvantages of the pump are the size of the complete assembly and its weight. For this reason, this type of pump is used in patrol and transport aircraft.

There are other features incorporated in the motor-driven variable displacement pump that you should know about. A thermal protector manual reset button is installed on the end of the motor, which is concealed by a cover plate. See figure 12-21. This thermal protector is a safety device that protects the

motor from overheating. The reset button will open and stop the motor when the temperature exceeds $380^{\circ} \pm 10^{\circ}\text{F}$. If the motor does not restart after cooling, the cover plate over the reset button should be removed and the reset button reset manually. If the motor still fails to start, the motor pump assembly should be replaced.

The motor-driven variable displacement pump suction line is connected from the reservoir to the suction port of the pump assembly, where fluid is ported into the center of a centrifugal pump scroll. The scroll is located between the main pump case and the motor reduction gearbox of the pump assembly. See figure 12-21. The scroll houses a centrifugal booster pump, which is mounted directly on the main pump shaft. The constant-speed motor turns the pump shaft through reduction gears at 3,200 rpm, which is sufficient to boost the fluid pressure about 15 to 20 psi above the existing reservoir pressure. The output of this integral pump is directed to two points on opposite sides of the scroll housing. See figure 12-22.

One delivery point provides a constant flow of hydraulic fluid for motor cooling through an internal passage. Finned baffle-like passages direct this flow

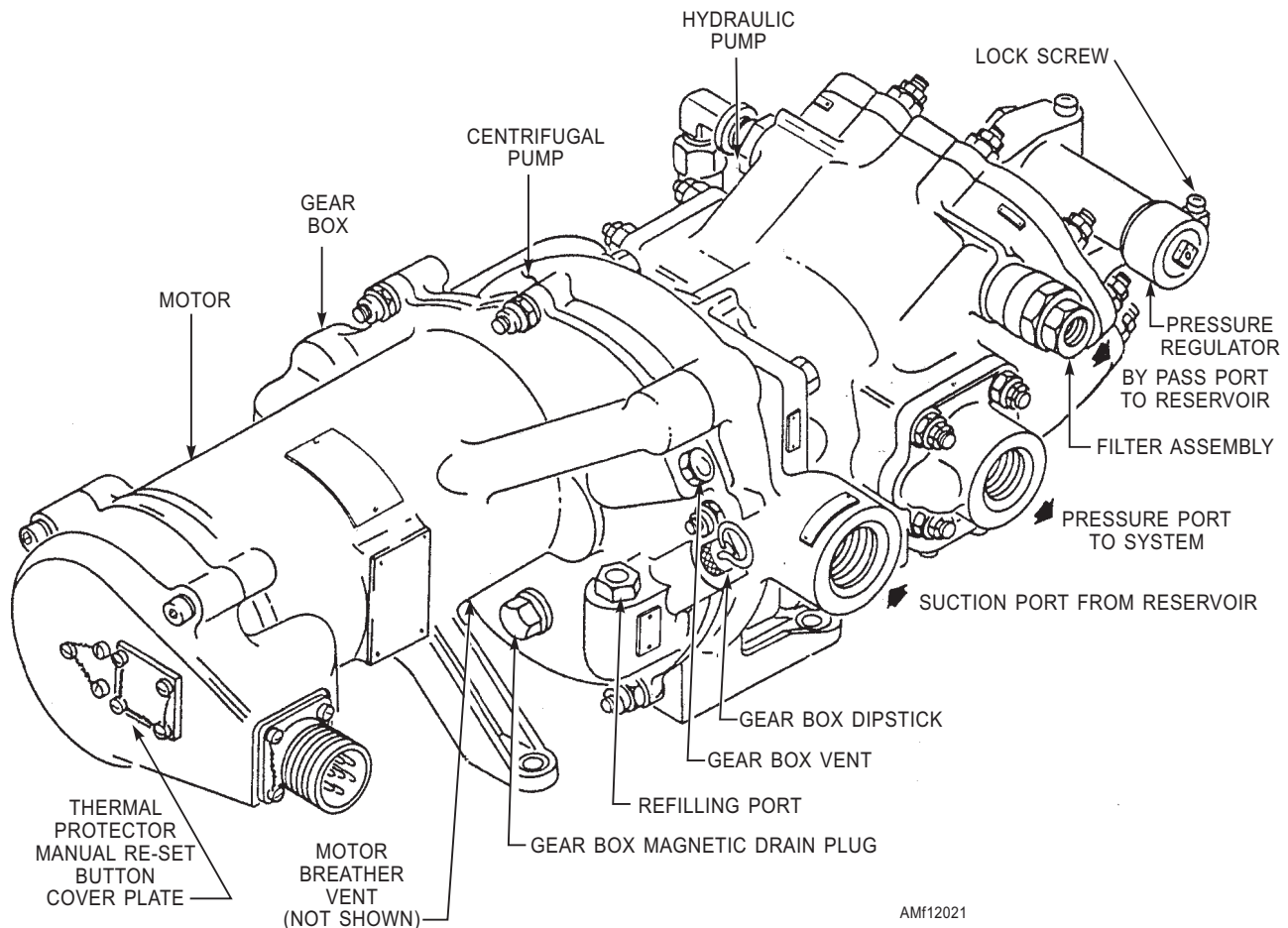

Figure 12-21.—Motor-driven variable displacement piston pump.

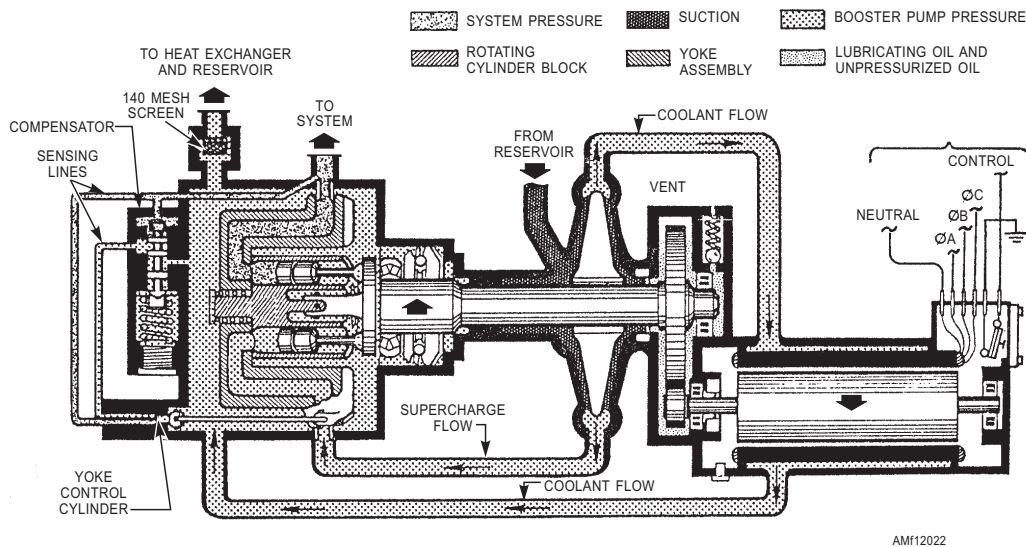

Figure 12-22.—Motor-driven variable displacement piston pump schematic.

around the motor through the hollow-walled motor case, after which it is directed by an external line into the case of the piston pump. This constant flow through the low-pressure chamber of the main pump cools and lubricates all of its moving parts. It also picks up “blow-by” oil that escapes past the high-pressure pump pistons, and is discharged through a coarse-screen filter cartridge installed in the case drain port. The pump’s coolant flow is routed through the aircraft’s heat exchanger and back to the reservoir.

The second delivery point from the integral centrifugal pump is directed from the centrifugal pump scroll at positive pressure to the intake port of the high-pressure pump. As you can see in figure 12-22, the Vickers motor-driven variable displacement design is similar to other engine-driven designs. The rotating assembly consists of a baseplate, to which nine piston rods are joined. The assembly turns in a fixed plane. Also turning with it is a cylindrical nine-piston block fitted inside a nonrotating yoke. The yoke is pivot-mounted to the pump case, and has an offset attachment for a compensator piston rod that controls the yoke’s attitude. If the yoke is not deflected, the cylinder block containing the pistons will rotate in a plane parallel to the baseplate, thus producing no stroke. The yoke can be tilted to displace the pistons, reaching maximum stroke when the yoke is tilted 30 degrees from the plane of rotation of the baseplate.

The pump compensating mechanism receives a feedback signal of system pressure, and adjusts the pump output by tilting the yoke a prescribed amount to

provide more or less flow. Whereas engine-driven pumps are generally rated to produce a given pressure and flow at a nominal drive speed, the electric motor-driven pump has a fixed rotational speed and a special compensating mechanism that enables the pump to provide 6 gpm (gallons per minute) at 2,950 to 3,000 psi. It will provide more flow as system pressure drops, reaching a maximum flow of 8 gpm at 2,200 psi. The accelerated flow enables the system to maintain normal speed of many actuators in use simultaneously.

Figure 12-23 shows the three phases of pump compensation in a pressure buildup order, starting at low pressure and increasing to full system pressure. As shown in view (A), the yoke control piston is spring loaded to hold the displacement yoke at its maximum displacement angle of 30 degrees. This spring is opposed by the existing system pressure, which acts at all times on the “constant horsepower” piston area; however, the hydraulic force will not be sufficient to move the yoke control piston until the actuating pressure (system pressure) builds up to 2,200 psi. Thus, the cylinder block will be canted to its maximum angle, and the pump will deliver its maximum flow, 8 gpm, when system pressure is less than 2,200 psi.

View (B) of figure 12-23 shows how the yoke control piston responds to system pressure fluctuations in the 2,200 to 2,950 psi range. Assuming that system pressure is steadily increasing, the displacement yoke angle will decrease from the 30-degree full displacement angle to approximately 22 degrees, which will produce 6 gpm at 2,950 psi.

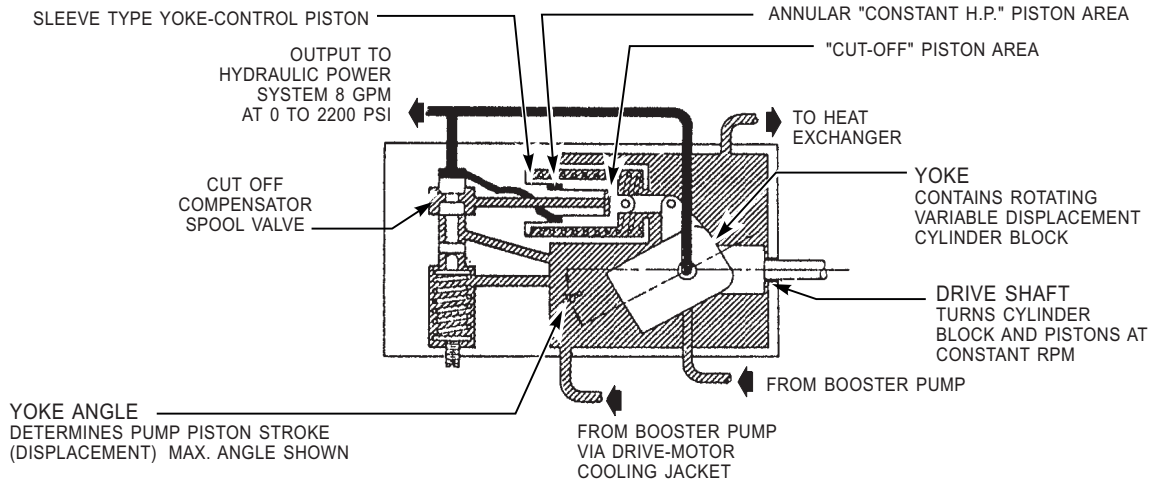

A

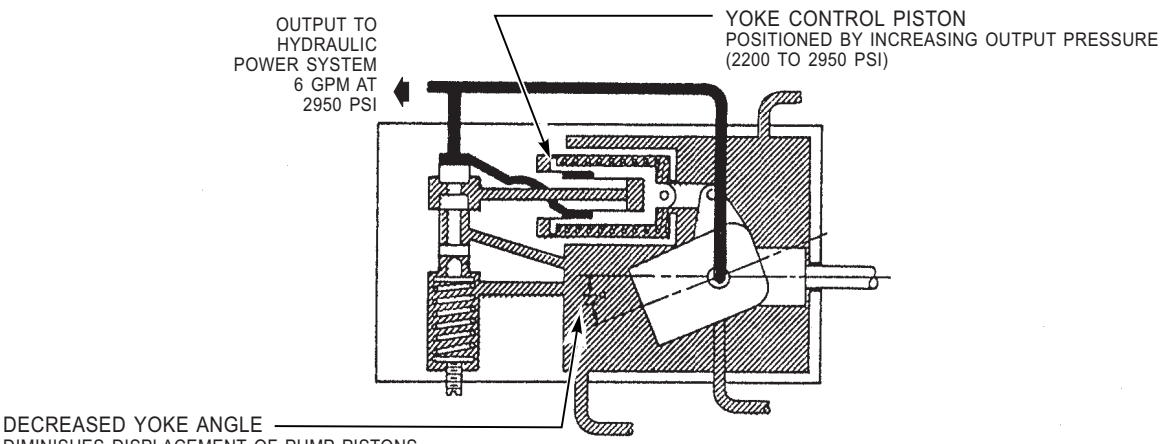

B

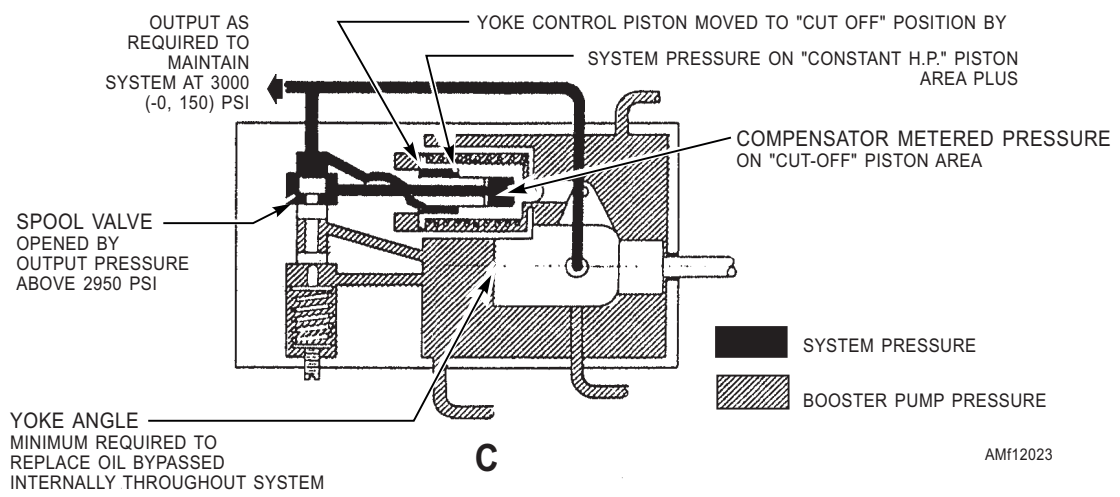

C

AMf12023

Figure 12-23.—Pump compensation. (A) full flow position; (B) reduced flow; (C) minimum flow.

View (C) of figure 12-23 shows how the spring load on the compensator spool is overcome by system pressure in excess of 2,950 psi, and the displaced spool meters pressure to the “cutoff” area of the yoke control piston. This pressure will act with the “constant hp” force on the piston, and with increasing pressure, the piston will move rapidly from the 22-degree displacement angle at 2,950 psi to approximately 0 degrees at 3,000 (plus 150, minus 0) psi.

When full pressure exists, the hydraulic power output will be the minimum required to replace fluid that leaks internally. The gearbox installed between the motor and pump contains lubricating fluid for internal lubrication, a dipstick for checking its fluid level, fill port to replace fluid, drain port to drain fluid during maintenance, and a relief valve to allow excess fluid to be relieved overboard. The pump gearbox is drained and reserviced with clean hydraulic fluid as follows:

1. Remove the magnetic drain plug and catch the fluid in a suitable container.
2. Inspect the magnetic plug for foreign particles that may have accumulated during periods of operation. Particles that look and feel like “fuzz” are considered acceptable; however, particles containing metal “slivers” require pump overhaul.
3. Remove the filler plug, and flush the gearbox with hydraulic fluid.
4. Clean the magnetic plug, install with a new gasket, and lockwire after replacing.
5. Refill gearbox with hydraulic fluid.
6. Install filler plug and dipstick, using new gaskets.

Also, the pump pressure line, fitting, and filter screen are removed. The filter screen is cleaned, using Dry-Cleaning Solvent P-D-680, and reinstalled using a new gasket. The pump pressure line is reinstalled and an operational check performed.

NOTE: Hydraulic pumps that are not functioning properly can represent a serious source of contamination in an operating hydraulic system.

RELIEF VALVES

Relief valves are not new to most people; different types of relief valves are used in our homes and automobiles, as well as many other places. Relief valves are pressure limiting or safety devices commonly used to prevent pressure from building up to

a point where it might blow seals or burst or damage the container in which it is installed, etc.

In aircraft, relief valves are installed within hydraulic systems to relieve excessive pressurized fluid caused from thermal expansion, pressure surges, and the failure of a hydraulic pump’s compensator or other regulating devices.

Main System Relief Valves

Main system relief valves are designed to operate within certain specific pressure limits and to relieve complete pump output when in the open position.

Relief valves are set to open and close at pressures determined by the system in which they are installed. In systems designed to operate at 3,000 psi normal pressure, the relief valve might be set to be completely open at 3,650 psi and reseal at 3,190 psi. These pressure ranges may vary from one aircraft to another. When the relief valve is in the open position, it directs excessive pressurized fluid to the reservoir return line.

Figure 12-24 shows a typical main system relief valve and its component parts breakdown. The relief valve consists of a cylindrical housing that contains a poppet valve and piston assembly. Each end of the housing is fabricated to include a wrench-holding surface and a threaded port for installation of a hydraulic fitting, and the housing is stamped to identify the ports as PRESS (pressure) and RET (return).

A coil spring at one end of the piston retains it against a stop on the valve housing; and the poppet valve, which is located just inside the pressure port, is spring seated over a passage through the valve. When fluid pressure at the pressure port reaches 3,650 psi, the pressure forces the piston to depress the coil spring and move clear of the poppet valve. Thus, the passage through the piston is opened, and fluid flows through the valve into the return line. When pressure at the pressure port is reduced to 3,190 psi, the coil spring reseats the piston against the poppet valve, and fluid flow through the relief valve ceases. Should the pressure at the outlet port exceed the pressure at the inlet port, the poppet valve will unseat, and fluid from the return line will flow through the valve into the pressure line.

Thermal Relief Valves

Thermal relief valves are usually smaller as compared to system relief valves. They are used in systems where a check valve or selector valve prevents

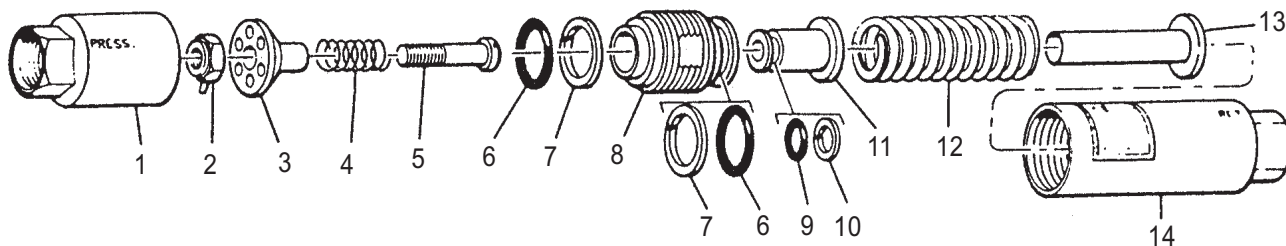
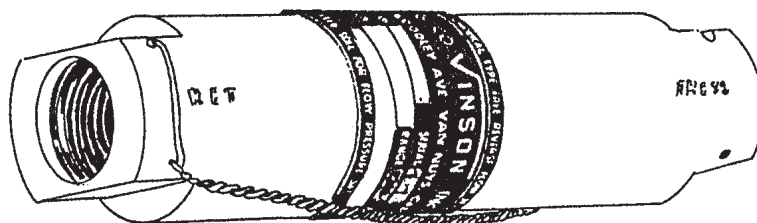

- 1. INLET BODY
- 2. NUT
- 3. GAUGE
- 4. POPPET SPRING
- 5. POPPET

- 6. PACKING
- 7. RING
- 8. SLEEVE
- 9. PACKING
- 10. RING

- 11. PISTON
- 12. LOAD SPRING
- 13. SPIGOT
- 14. OUTLET BODY

Figure 12-24.—System relief valve.

AMF12024

pressure from being relieved through the main system relief valve.

Figure 12-25 shows a typical thermal relief valve. As pressurized fluid in the line in which it is installed builds up to an excessive amount, the valve poppet is forced off its seat; this allows excessive pressurized fluid to flow through the relief valve to the reservoir return line, as shown in view B of figure 12-25. When system pressure decreases to a predetermined pressure, spring tension overcomes system pressure and forces the valve poppet to the closed position, as shown in view A.

Relief valve maintenance is limited to adjusting the valve for proper relieving pressure and checking the valve for leakage. If you think a relief valve is leaking internally, a flexible hose may be connected to the return port of the valve and the drippings, if any, caught in a container. The opening and closing pressure of the valve may also be checked in this manner provided an external source of power is used.

To adjust the opening pressure of a relief valve, turn the adjusting screw clockwise to increase opening pressure and counterclockwise to decrease opening pressure.

CAUTION

Do not attempt to adjust a relief valve while it is installed on an aircraft. This action will result in an incorrect pressure setting. The valve must be removed and adjusted on a test stand to ensure proper pressure settings.

SHUTOFF VALVES

All hydraulic systems do not have shutoff valves incorporated; however, in some systems a shutoff valve is installed in the fluid supply line between the reservoir and the engine-driven pumps, and other places where shutting off the fluid is desirable. These valves, like other valves, may be electrically or manually controlled, depending upon the design of the valve.

The purpose of shutoff valves differ according to their installation. All shutoff valves control the flow of fluid; however, they may isolate troubles by shutting off a complete system or subsystem, or they may control the speed a component moves by partially closing the valve (manual type).

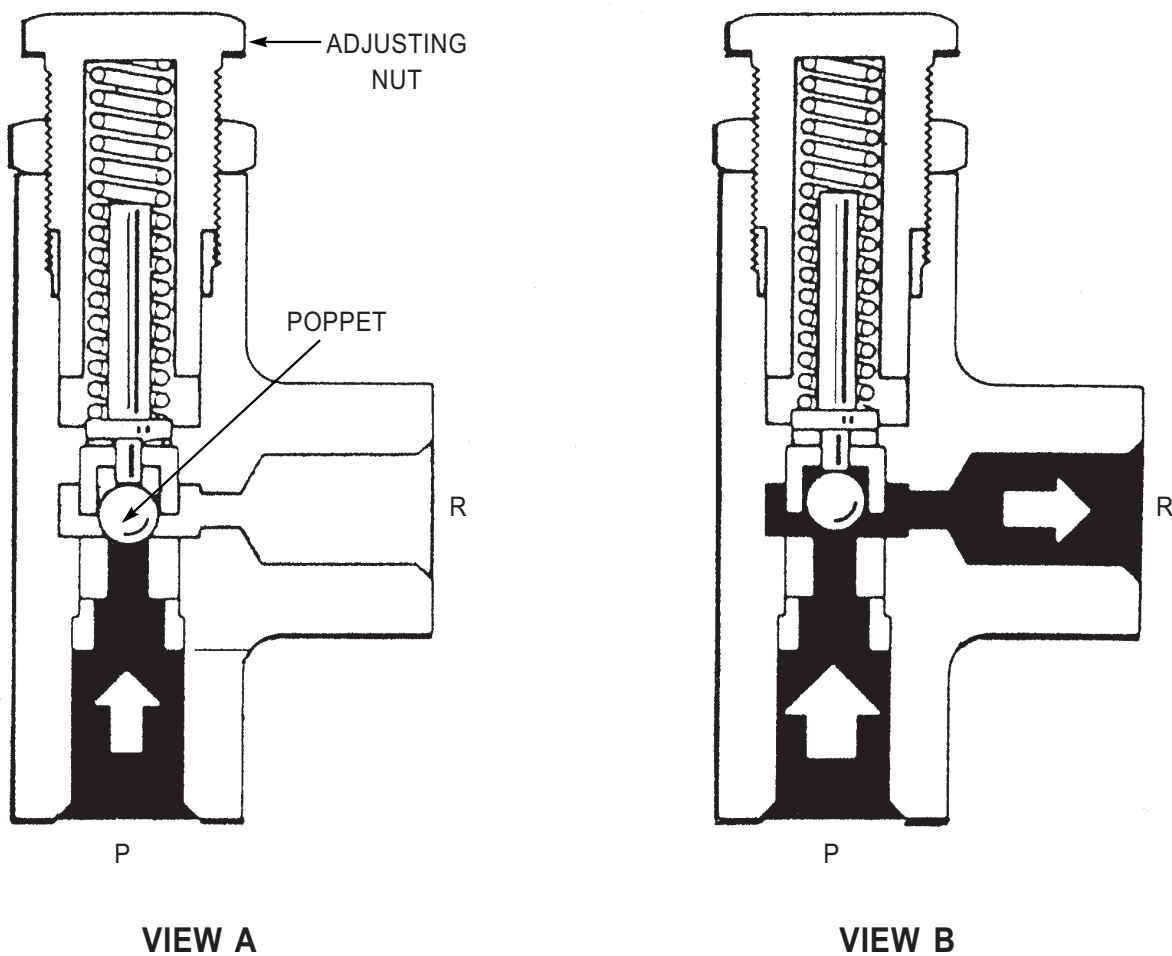

Figure 12-25.—Typical thermal relief valve.

AMF12024

Motor-Operated Shutoff Valves

The purpose of the shutoff valve, shown in figure 12-26, is to shut off the flow of hydraulic fluid to the engine in case of an engine fire. The valve may also be used to great advantage during replacement of line quick-disconnects and other maintenance functions. There are usually other shutoff valves, identical in appearance, installed within the same area that prevent oil and fuel from reaching the engine in case of an engine fire.

When the shutoff valve is energized, an electrical impulse is applied to the electrical connector on the motor, which converts the electrical energy into rotary motion of the actuator output shaft by the means of a gear train. This rotary motion is then transmitted to the shaft, which couples the actuator output shaft to the crank assembly. The crank assembly then transmits the rotary motion of the shaft to the linear motion of the

slide. The amount of rotation of the valve output shaft is controlled by means of limit switches in the motor and gear assembly, which interrupt current to the motor. When the valve is in the open position, the slide is retracted into the valve body, thus permitting the flow of hydraulic fluid through the valve. When the valve is in the closed position, the slide is positioned between the inlet and outlet ports, thus shutting off the fluid flow.

The valve incorporates a visual position indicator (on the valve itself). The indicator is mechanically connected to the operating parts of the valve and provides a positive indication of the position of the valve.

CAUTION

Operating an engine with the fire wall shutoff valve closed could cause severe damage to the engine-driven pump.

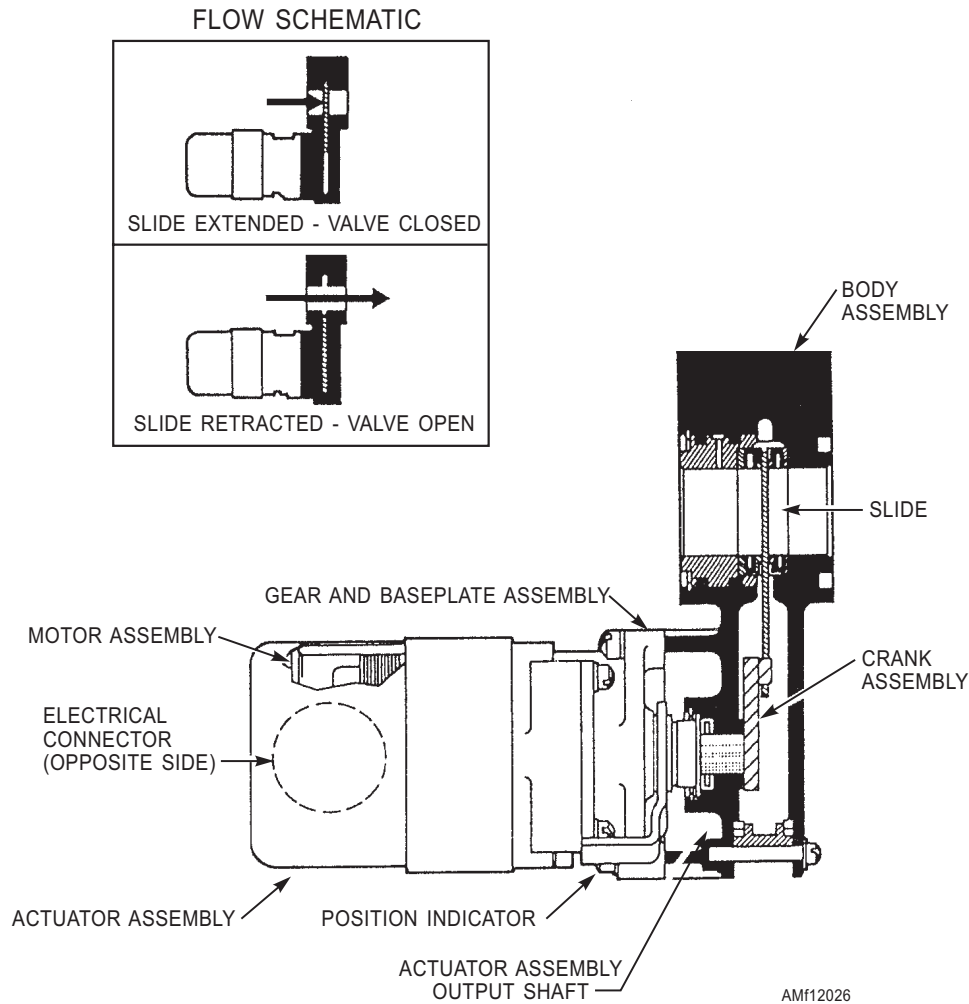

Figure 12-26.—Motor operated shutoff valve.

Electric Solenoid Shutoff Valve

The shutoff valve, shown in figure 12-27, is used to shut off the fluid flow to selected subsystems of a utility hydraulic system. It can also limit the use of all available utility system pressure for the operation of the primary flight controls or prevent fluid loss during flight when damage to the utility system has occurred. This valve is sometimes referred to as a *priority* valve and normally has three modes or conditions of operation.

CONDITION ONE (LANDING).—Flight control system pressure normal, switch in the landing position, solenoid deenergized, and the pilot ball on its lower seat, blocking the return port of the flight control system. See figure 12-27, View A. In this condition, the pressure of the flight control system is allowed to act upon the lower working area of the poppet, moving it upward off its seat and compressing the poppet spring. This action will allow the fluid of the utility system to flow downstream from the location of the valves to the landing gear, flaps, speed brakes, etc.

CONDITON TWO (FLIGHT).—Flight control system pressure normal, switch in the flight position, solenoid energized, and the pilot ball on its upper seat, preventing the pressure of the flight control system from working on the lower working area to the poppet. See figure 12-27, View B. In this condition, the return port of the flight system is open. The poppet spring will move the poppet onto its seat, preventing the fluid from the utility system from flowing downstream from the location of the valve. This allows all available fluid to be directed to the components of the utility section, such as the ailerons, rudder, stabilizer, spoilers, of the flight control subsystem.

CONDITION THREE (EMERGENCY).—Failure of the flight control hydraulic system. The flight control system pressure is 0 psi, and the utility system pressure is normal. During this condition, the poppet will remain on its seat, because the pressure of the flight control system is not available to work on the lower working area of the poppet to move it up to open the valve. See figure 12-27 View C.

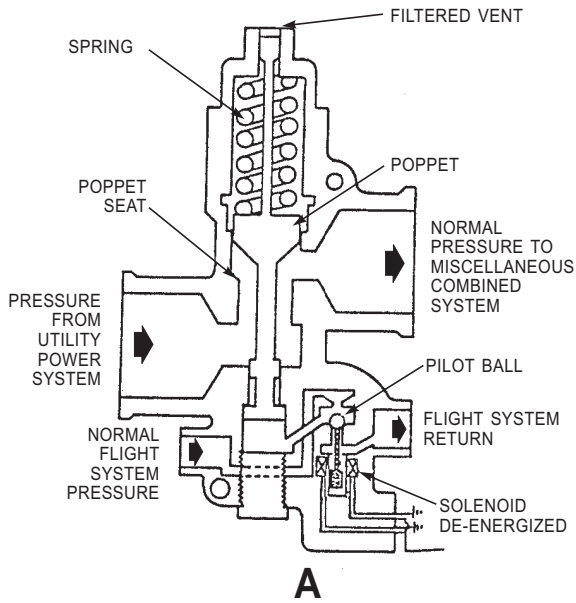

CONDITION 1

FLIGHT SYSTEM PRESSURE NORMAL. SOLENOID DE-ENERGIZED. NORMAL FLOW TO MISCELLANEOUS SYSTEMS.

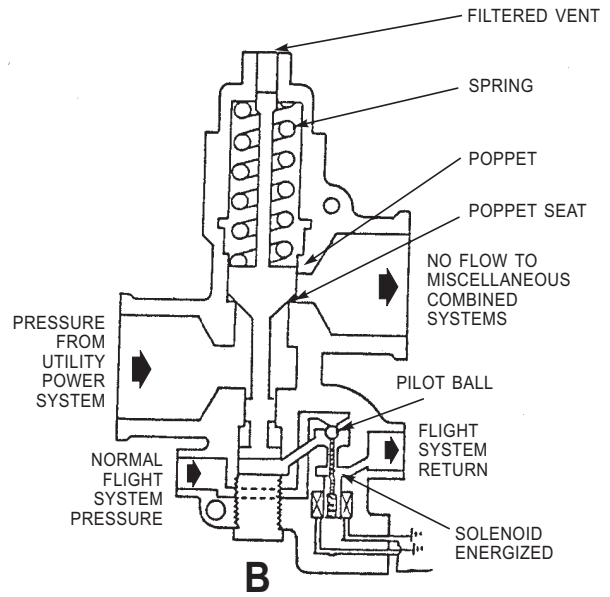

CONDITION 2

FLIGHT SYSTEM PRESSURE NORMAL. SOLENOID ENERGIZED. NO FLOW TO MISCELLANEOUS SYSTEMS.

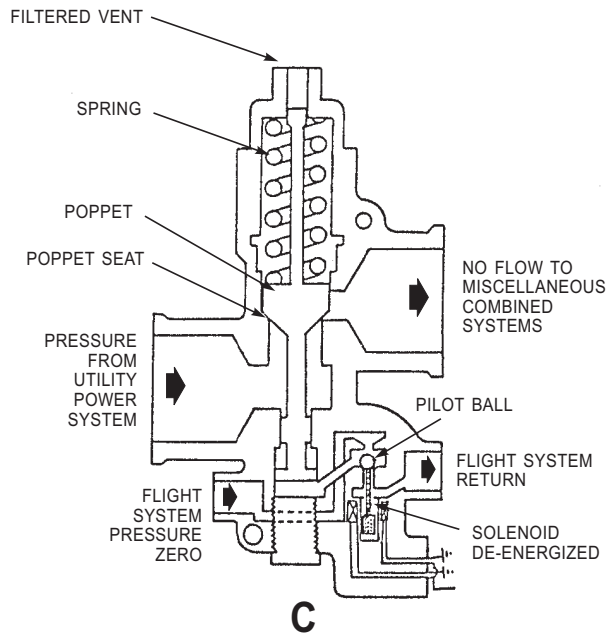

CONDITION 3

LOSS OF FLIGHT SYSTEM PRESSURE. SOLENOID DE-ENERGIZED. NO FLOW TO MISCELLANEOUS SYSTEMS.

AMF12027

Figure 12-27.—Electric solenoid shutoff valve.

Failure of the electrical system to the electrohydraulic shutoff valve. The pressures of the flight control and utility systems are normal, and there is no electrical power to the solenoid. In this condition, the solenoid cannot be energized, the pilot ball will

remain on its lower seat, and the pressure of the flight control system will work on the lower working area. This holds the poppet of its seat and allows the pressure of the utility systems to flow downstream from the location of the valves.

Manual Shutoff Valves

Manual shutoff valves may be used as fire wall shutoff valves as well as subsystem shutoff valves. Some aircraft have a manual fire wall shutoff valve operated by cable linkage.

Some aircraft use the needle-type shutoff valve in their landing gear and bomb bay systems. This needle-type valve consists of a handle, stem and valve, and body. Turning the handle in a clockwise direction places the valve on its seat within the body, stopping the flow of fluid.

These shutoff valves are used during maintenance to shut off hydraulic fluid to the subsystems, thus allowing maintenance personnel to work safely in the wheelwell and bomb bay areas. Also, by closing the particular valve a desired amount, the speed of the operating unit can be controlled to aid in observing the sequence and full operation of the components being operated.

HYDRAULIC FLUID COOLERS

Hydraulic fluid coolers are used in some hydraulic systems for the purpose of lowering the temperature of the fluid within the system lines, thus preventing inadvertent overboard dumping of fluid from the reservoir due to thermal expansion. Fluid coolers are installed in systems in which the temperature of the fluid is likely to exceed the maximum allowable limit.

According to the military specifications for aircraft hydraulic systems, 400°F is the maximum allowable temperature for any type of hydraulic system. In some systems, this temperature might be exceeded without some means of cooling the fluid.

Several types of fluid coolers are used on naval aircraft. The most common is the radiator type, in which both the hydraulic fluid and engine fuel flow separately through the cooling unit. Another radiator type uses ram air in flight and an electric blower while on the ground to produce an air source as a cooling medium.

Radiator Types

Radiator-type fluid coolers are also called heat exchangers and fluid coolers, as well as radiators. Their principles of operation are the same; however, the manner in which they obtain their objective may differ.

On some aircraft, the radiator is a welded aluminum assembly with two semicylindrical and baffled hydraulic fluid chambers with multiple pencil diameter size tubes, which direct and contain fuel flow through the individual hydraulic chambers. The radiator is so constructed to prevent mixing of engine fuel with hydraulic fluid and one hydraulic system fluid with the other. As fuel flows through the radiator tubes, heat energy is transferred from the hydraulic fluid to the engine fuel prior to hydraulic fluid entry into the hydraulic reservoir.

Figure 12-28 shows the cooling radiator used to cool two hydraulic systems; moreover, it has a fuel filter incorporated that filters the fuel supplied to the engine. The radiator unit consists of a cylindrical case containing two cooling coils of 1/4-inch aluminum alloy tubing and a replaceable fuel filter element. The utility system cooling coil is installed in the right-hand end of the case; the flight control system cooling coil and the filter element are installed in the left-hand end, as shown in figure 12-28. The case ends contain fittings for connecting fuel hoses. Two threaded bosses, which are welded to the cooling coil ends, serve to connect the hydraulic lines for each system. During normal operation, hydraulic fluid returning to each reservoir is directed through its applicable system cooling coil, where sufficient heat is transferred to the engine fuel to maintain the hydraulic fluid at less than 200°F.

Should the cooling coils become clogged, each system is equipped with a bypass relief valve, which opens and bypasses fluid around the coil and directly to the reservoir.

Fin Tubing Types

Some aircraft use fin tubing for cooling hydraulic system fluid. Hydraulic fluid coolers are mounted internally in the wing inboard fuel tanks. As shown in figure 12-29, each cooler is an assembly of fin-walled tubing, two unions, and mounting supports. Fluid enters the inlet coupling and is passed through the fin-walled tubing, which acts as a heat exchanger, and is directed to the outlet coupling for return to the system reservoir. The heat of the fluid passing through the coolers is absorbed by both the fin-walled tubing and the fuel.

NOTE: The fuel level in the inboard tanks must be maintained at a specific level to ensure adequate cooling of the fluid.

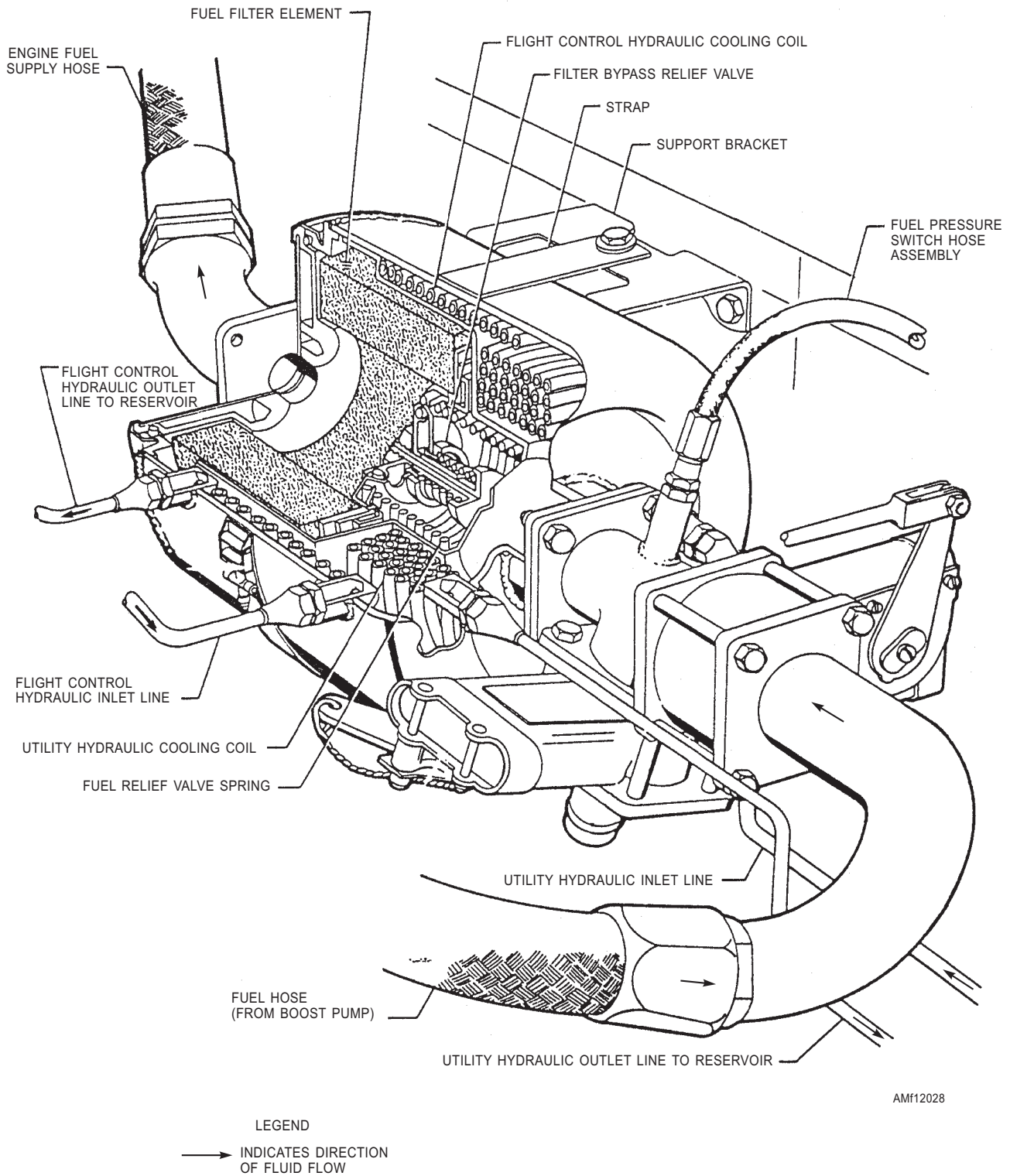

AMF12028

Figure 12-28.—Hydraulic fluid cooler.

MANIFOLDS

A manifold is a hydraulic component used to conserve space and permit ease of unit removal and replacement. It also provides a means where common fluid lines may come together and be distributed to other subsystems. Manifolds are used in various types

of installations, depending upon the needs of the system.

Figure 12-30 shows two views of a manifold. This manifold joins both the pressure and suction lines from the No. 1 system pumps and the suction line from the emergency system pump. The assembly includes

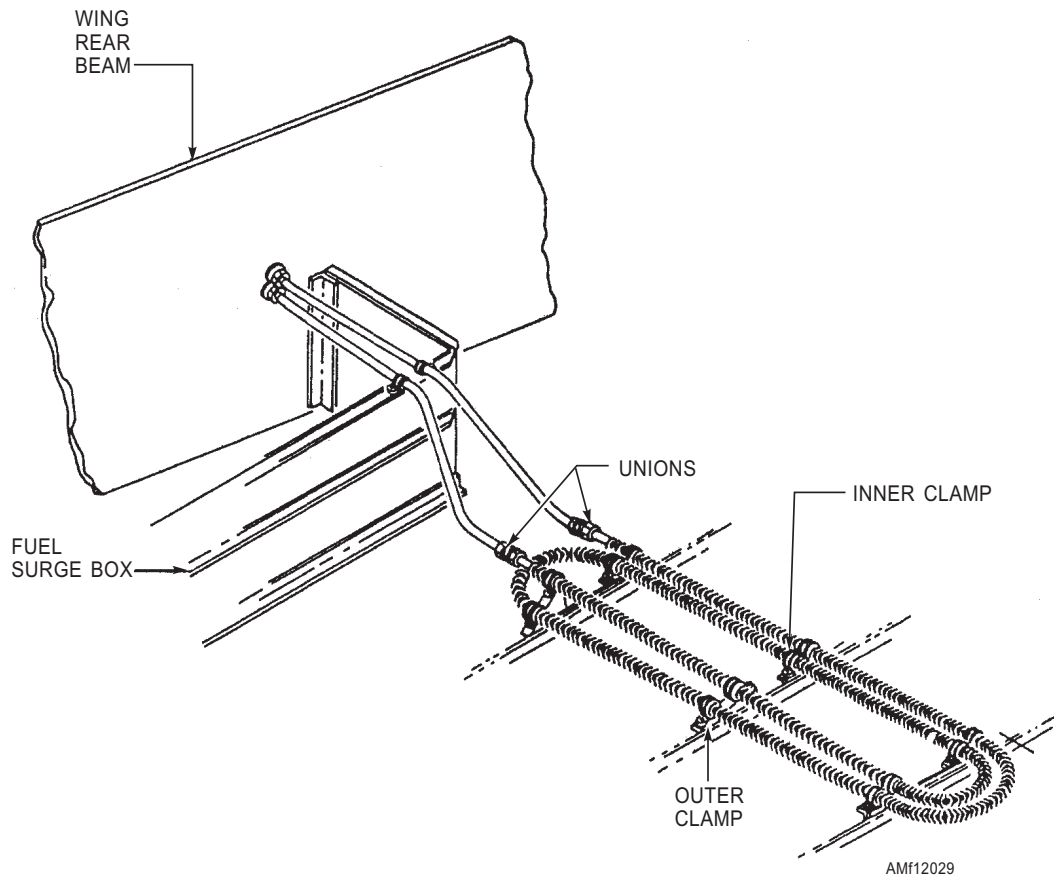

Figure 12-29.—Fin tubing assembly installation.

integral check valves to direct the flow of fluid through the manifold, filters to clean the fluid prior to its entry into the main system, and quick-disconnect fittings for the connection of ground test hydraulic equipment.

FILTERS

Hydraulic fluid will hold in suspension tiny particles generated during normal wear of selector valves, pumps, and other system components. These minute particles may damage or impair the function of the units and parts through which they pass if they are not removed by a filter. Because close tolerances exist within a hydraulic system, the performance and reliability of the entire system depend upon adequate filtration.

Continuous filtration of hydraulic fluid during system operation is necessary to maintain system cleanliness. You should use filters that have fine pores or openings to allow hydraulic fluid to pass but that are small enough to trap contaminant particles. Hydraulic filter elements are rated in several ways. The absolute filtration rating is the diameter in microns of the largest spherical particle that will pass through the filter under a certain test condition. This rating is an indication of the largest opening in the filter element. The mean

filtration rating is the measurement of the average size of the openings in the filter element. The nominal filtration rating is usually interpreted to mean the size of the smallest particles of which 90 percent will be trapped in the filter at each pass through the filter. Figure 12-31 shows a typical filter arrangement in a hydraulic system.

Filters may be located within the reservoir, the pressure line, the return line, or any other location where they are needed to safeguard the hydraulic system against contaminants. Their location in the system and other design criteria determine their shape and size.

Basic Units

The filter assembly is composed of three basic units. The units are a head assembly, a bowl, and a filter element. See figure 12-32.

HEAD ASSEMBLY.—The head assembly is secured to the aircraft structure and connecting lines. The head assembly of some filters have a pressure-operated bypass valve, which will route the hydraulic fluid directly from the inlet to the outlet port

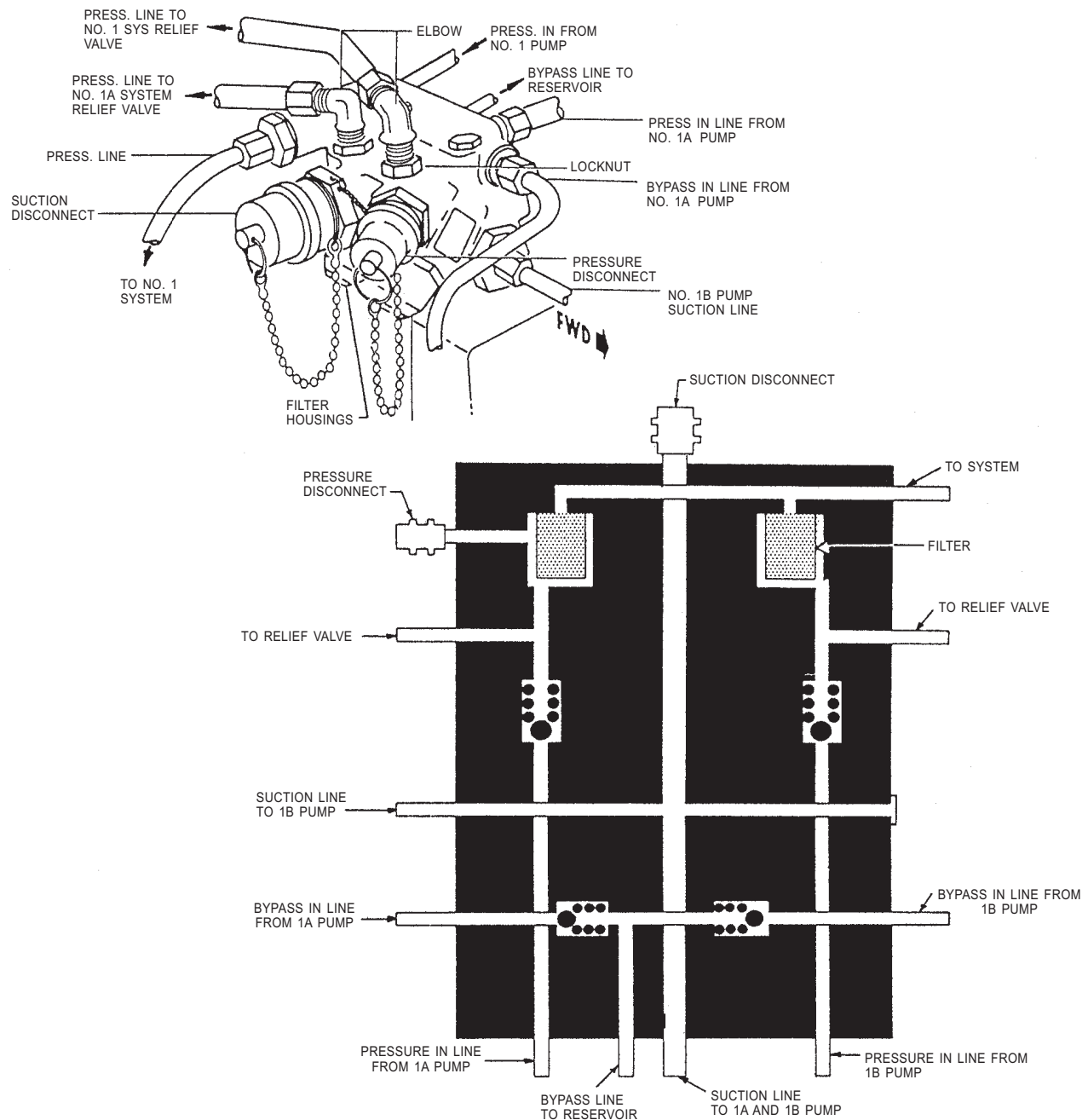

Figure 12-30.—Hydraulic manifold assembly.

AMF12030

if the filter element becomes loaded with foreign matter.

BOWL.—The bowl is the housing that holds the element to the filter head, and it is removed when element replacement is required.

FILTER ELEMENT.—The filter element may be of the 5-micron noncleanable, woven mesh, micronic, porous metal, or magnetic type. The micronic and 5-micron noncleanable elements have nonmetallic filter media, and are discarded when removed. Porous metal, woven mesh, and magnetic

filter elements are usually designed to be cleaned and reused. However, some metallic filters are considered noncleanable and are normally discarded.

Noncleanable filter elements rated at 5-microns (absolute) represent the current state of the art in hydraulic filtration. Elements of this type afford significantly improved filtration and have greater dirt-holding capacities than other types of elements of the same physical size. They are particularly effective in controlling particles in the 1- to 10-micron size range, which are normally passed by other types of elements, and they are capable of maintaining a

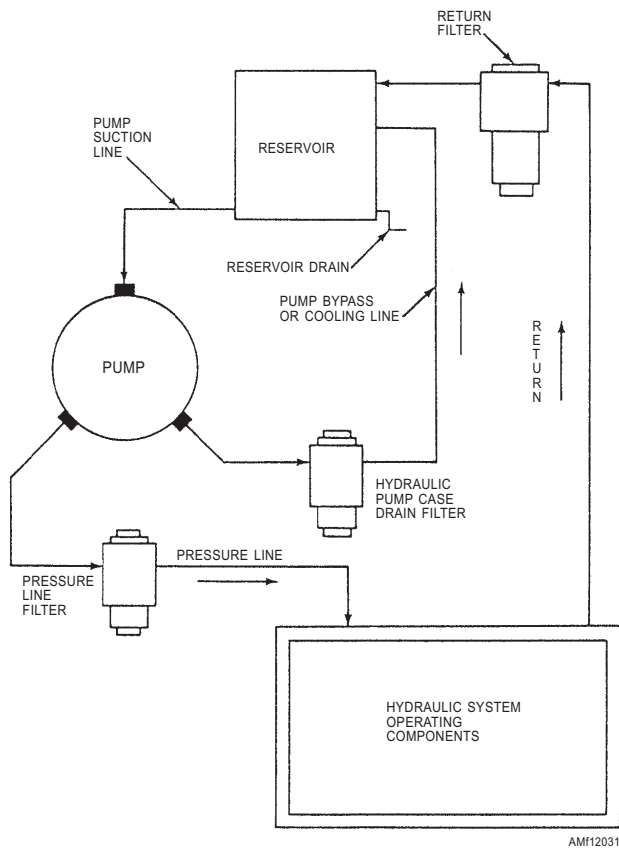

Figure 12-31.—Typical filter arrangement in hydraulic system.

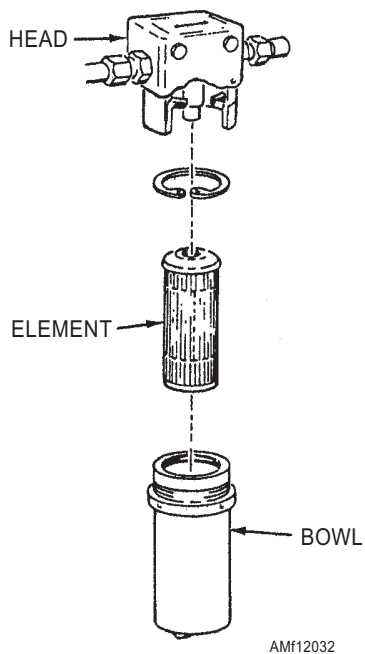

Figure 12-32.—Hydraulic filter assembly.

hydraulic system at much cleaner levels than could previously be achieved. The use of 5-micron (absolute) filters is presently specified for all new design aircraft, and they are being retrofitted to existing fleet aircraft where practicable.

The most common 5-micron filter medium is composed of organic and inorganic fibers integrally bonded by epoxy resin and faced with a metallic mesh upstream and downstream for protection and added mechanical strength. Filters of this type are not to be cleaned under any circumstances, and will be marked **DISPOSABLE** or **NONCLEANABLE**, usually on the bottom end cap.

Five-micron, noncleanable, hydraulic filter elements should be replaced with new elements during specified maintenance inspection intervals in accordance with the applicable procedures. Refer to the applicable MIM or maintenance requirement cards (MRC) for replacement intervals and procedures.

Another 5-micron filter medium of recent design employs layers of very fine stainless steel fibers drawn into a random but controlled matrix. The matrix is then processed by an exclusive procedure, which in successive steps compresses and sinters (bonds all wires at their crossing points) the material into a thin layer with controlled filtration characteristics. Filter elements of this material may be cleanable or noncleanable, depending upon their construction, and are marked accordingly.

Support Equipment (SE) Filters

To ensure delivery of contaminant-free hydraulic fluid, all SE must be provided with 3-micron (absolute) non-bypass filtration in their fluid discharge or output pressure lines. With many test stands, the filter used for this application, in addition to having a low micron rating, must be capable of withstanding high-collapse pressures and holding large amounts of dirt.

Unlike most filter elements, 3-micron, high-pressure SE filters are not normally replaced on a prescribed periodic basis. Because of their large dirt-holding capacity and nature of service, it is more effective to replace such elements only when indicated as being loaded by their associated differential pressure indicators. Element replacement procedures vary with the particular type, and applicable maintenance instructions should be consulted for specific procedures.

Differential Pressure Indicators

The extent to which a filter element is loaded can be determined by measuring the drop in hydraulic pressure across the element under rated flow conditions. This drop or “differential pressure” provides a convenient means of monitoring the

condition of installed filter elements, and is the operating principle used in the differential-pressure or loaded-filter indicators found on many filter assemblies. Differential pressure indicating devices have many configurations, including electrical switches, continuous-reading visual indicators (gauges), and visual indicators with memory. Visual indicators with memory usually take the form of magnetic or mechanically latched buttons or pins that extend when the differential pressure exceeds that allowed for a serviceable element. See figure 12-33. When this increased pressure reaches a specific value, inlet pressure forces the spring-loaded magnetic piston downward, breaking the magnetic attachment between the indicator button and the magnetic piston. This allows the red indicator to pop out, signifying that the element must be cleaned. The button or pin, once extended, remains in that position until manually reset and provides a permanent (until reset) warning of a loaded element. This feature is particularly useful where it is impossible for an operator to continuously monitor the visual indicator, such as in an aircraft. Some button indicators have a thermal lockout device incorporated in their design that prevents operation of the indicator below a certain temperature. The lockout prevents the higher differential pressure generated at cold temperatures by high fluid viscosity from causing a false indication of a loaded filter element.

Differential pressure indicators are a component part of the filter assembly in which they are installed, and, as such, are normally tested and overhauled as part of the complete assembly. With some model filter assemblies, however, it is possible to replace the indicator itself, without removal of the filter assembly, if it is suspected of being inoperative or out of calibration. It is important that the external surfaces of button-type indicators be kept free of dirt or paint to ensure free movement of the button.

Indications of excessive differential pressure, regardless of the type of indicator employed, should never be disregarded. All such indications must be verified and action taken, as required, to replace the loaded filter element. Failure to replace a loaded element can result in system starvation, filter element collapse, or the loss of filtration where bypass assemblies are used. Verification of loaded filter indications is particularly important with button-type indicators, as they may have been falsely triggered by mechanical shock, vibration, or cold start of the system. Verification is usually obtained by manually resetting the indicator and operating the system to

create a maximum flow demand, ensuring that the fluid is at near normal operating temperatures.

Maintenance

Hydraulic filter maintenance consists of filter element replacement only. You must be familiar with both replacement and general inspection procedures.

Replacement of hydraulic filter elements is normally a maintenance operation performed on a periodic basis, but need for prior replacement may be indicated during routine inspection. Hydraulic filter assemblies in some aircraft and SE are equipped with indicating devices (buttons or pins) that will extend when the differential pressure across the filter exceeds a predetermined value, indicating a loaded element. Upon appearance of this indicator, it becomes necessary to verify the condition of the filter element, and replace it if required. When checking or changing filter elements, also check the functioning of any pop-up mechanism.

Indications of a loaded filter must be verified to confirm that release of the button or pin is due to a loaded filter and not a result of system mechanical shock or cold start. Verification is accomplished by resetting the indicator (manually depressing it) and operating the system at full power. If the differential pressure indicator extends again during this test, the filter element should be replaced.

It is important that the applicable MIM be consulted for specific filter element replacement procedures. The following basic principles apply to most replacement operations:

1. Removal of the filter bowl is the first step in replacing the filter element. With most filter assemblies, this operation usually consists of removing a lockwire and unscrewing the bowl from the filter head. In most filter assemblies, an automatic shutoff valve in the head will prevent fluid loss from the system when the bowl is removed.

2. Once the bowl is removed, the fluid in it is discarded, and the bowl is cleaned of sediment by flushing with clean, unused hydraulic fluid or dry cleaning solvent, P-D-680. It is important that chlorinated solvents such as MIL-C-81302 or 1,1,1-trichloroethane are not used, as their residues may have harmful effect on the system.

3. The filter element is, in most instances, removed from the head by a gentle twisting and pulling motion. Once removed, the surface of the element should be

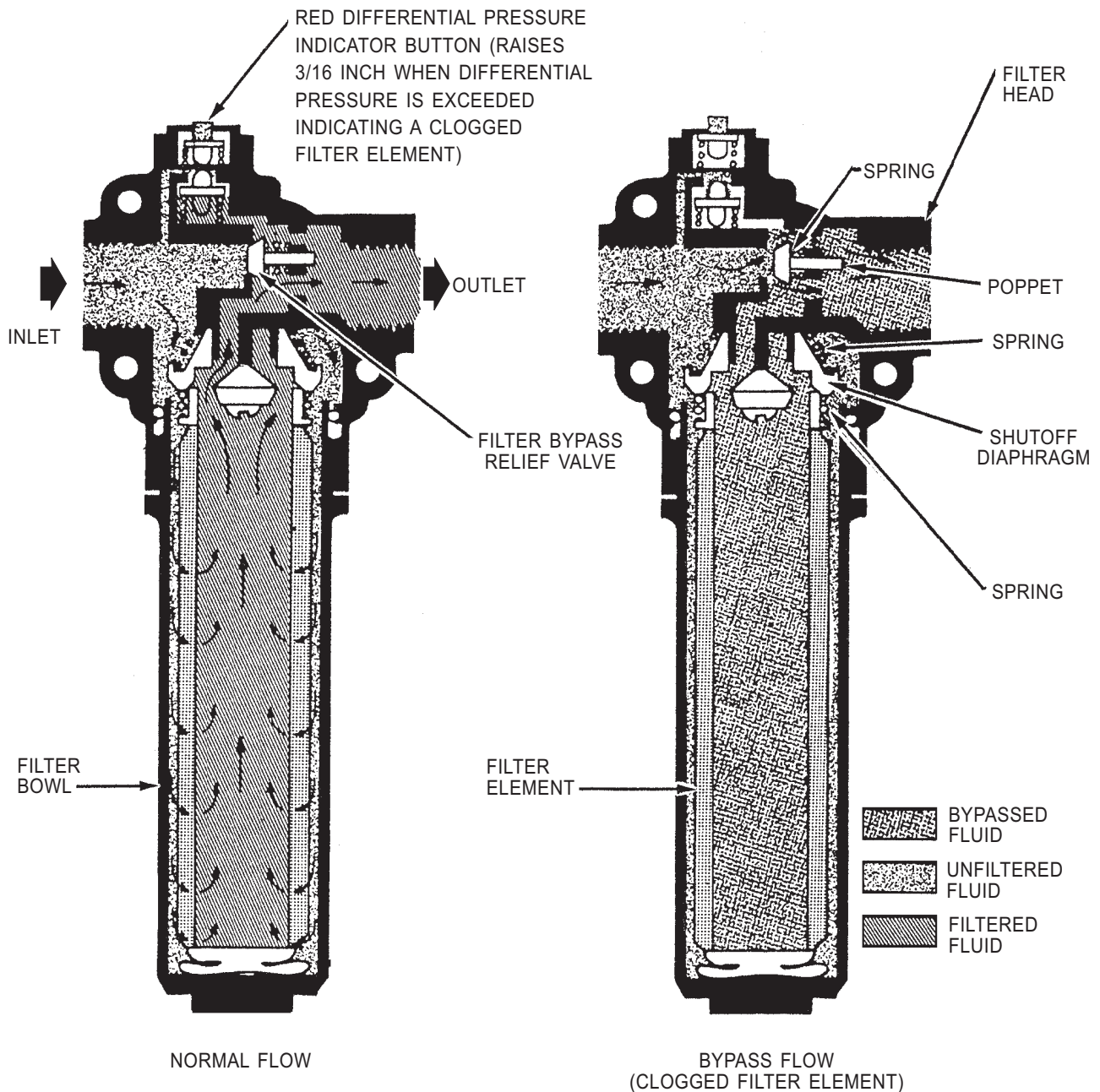

AMf12033

Figure 12-33.—Hydraulic filter assembly incorporating differential pressure indicator.

visually inspected. An excessive amount of particulate on its surface, as determined from experience, may be indicative of upstream component failure and the need for investigation. Check the solid end of filter element for “Disposable” markings. If the filter element is disposable, it should be discarded. If the filter element is not disposable, it should be cleaned and handled carefully.

4. The replacement filter element should not be removed from its protective packing until just prior to installation. Once removed from packing, the element

must be carefully handled to protect it from contamination and mechanical damage.

5. The replacement element is installed in reverse order of its removal. In most instances, the element is inserted up into the head, employing a gentle twisting motion. O-ring seals located in the head, or sometimes in the element itself, prevent fluid from flowing around the element. It is important that these seals be inspected and replaced, if required, in accordance with the applicable MIM.

6. Prior to installation of the cleaned filter bowl, the bowl is first filled with new filtered hydraulic fluid to

minimize the introduction of air into the hydraulic system. It is important that the fluid used for this operation be obtained only from an authorized hydraulic fill service unit.

7. Once filled, the filter bowl is carefully and slowly slid up over the installed element and screwed into the head. A quantity of fluid from the bowl will normally be displaced by the element and spilled. Provisions must be made to collect or absorb it.

8. The installed filter bowl should be torqued to the value specified in the applicable MIM. The bowl is then lockwired, using standard tools and the lockwire provisions in the filter assembly.

9. All filter element installations should be followed by test and inspection of the system to ensure proper operation. This is generally accomplished by operating the system at its normal pressure and flow rates and inspecting for external leakage at the filter assembly and for indications of excessive differential pressure. Any external leakage is unacceptable, and requires that the system be shut down and the problem corrected.

10. Should the filter assembly differential pressure indicator continue to extend after a new element has been installed, the indicator itself is probably defective. Consult the maintenance instructions to determine what corrective action is to be taken.

Inspect the filter element as follows:

1. Visually inspect the element for dents, broken wires, holes, creases, and sharp corners of pleats. Permissible damage is to be confined to small dents that will not impede the required flow, or increase the filter pressure drop beyond tolerance, or fail to pass the required bubble test point. Deeper dents, broken wires, holes, creases, and sharp corners of pleats are cause for rejection of elements.

2. Remove the O-ring from the filter element and visually inspect the O-ring groove, including chamfers, for nicks, dents, visible roughness, out-of-roundness, and pitting. Blend out nicks and/or scratches that are deeper than 0.002 inch with crocus cloth P-C-458.

3. Visually inspect mating surfaces, including chamfers, or other parts that mate with the O-ring grooves. Make sure that all surfaces (grooves and mating surfaces) are smooth and capable of sealing with the O-ring installed.

4. Dispose of unacceptable filter elements according to existing instructions.

ACCUMULATORS

The purpose of the accumulator in a hydraulic system is to store a volume of fluid under pressure. There are several reasons why it is advantageous to store a volume of fluid under pressure. Some of these are listed below:

1. An accumulator acts as a cushion against pressure surges that may be caused by the pulsating fluid delivery from the pump or from system operations.

2. The accumulator supplements the pump's output when the pump is under a peak load by storing energy in the form of fluid under pressure.

3. The energy stored in the accumulator may be used to actuate a unit in the event of normal hydraulic system failure. For example, sufficient energy can be stored in the accumulator for several applications of the wheel brakes.

There are two general types of accumulators in use on naval aircraft. They are the spherical type and the cylindrical type. Until a few years ago, the spherical type was the more commonly used accumulator; however, the cylindrical type has proved more satisfactory for high-pressure hydraulic systems, and is now more commonly used than the spherical type. Examples of both types are shown in figure 12-34.

Spherical Type

The spherical type accumulator is constructed in two halves that are screwed together. A synthetic rubber diaphragm is installed between both halves, making two chambers. Two threaded openings exist in the assembled component. The opening at the top, as shown in figure 12-34, contains a screen disc that prevents the diaphragm from extruding through the threaded opening when system pressure is depleted, thus rupturing the diaphragm. On some designs, the screen is replaced by a button protector fastened to the center of the diaphragm. The top threaded opening provides a means for connection of the fluid chamber of the accumulator to the hydraulic system.

The bottom threaded opening provides a means for installation of an air filler valve. This valve (when open) allows an air/nitrogen source to be connected to and enter the accumulator; moreover, when the valve is closed, it traps the air/nitrogen within the accumulator.

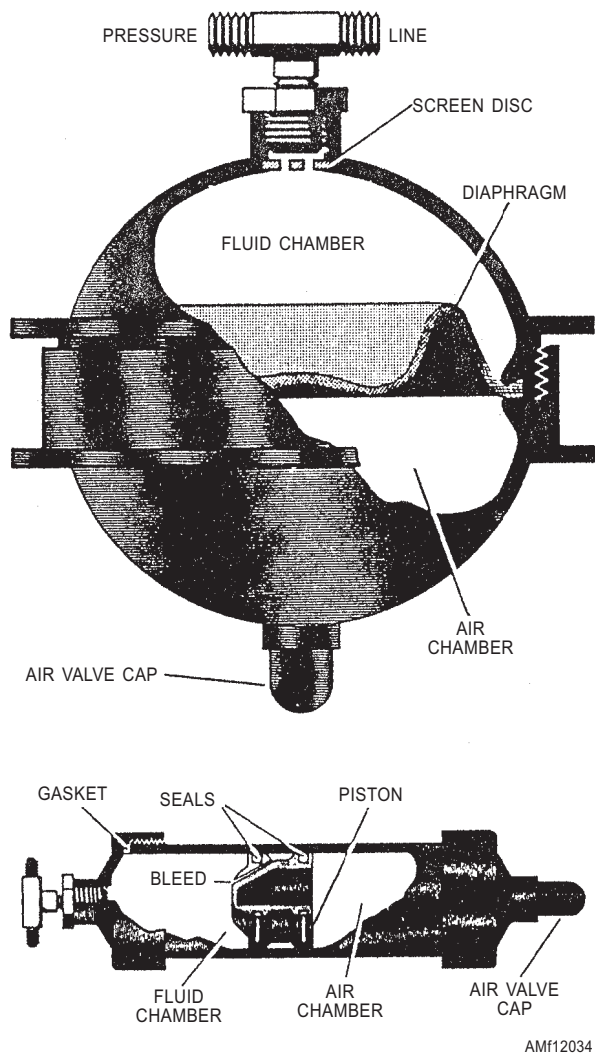

Figure 12-34.—Pressure accumulator, spherical and cylindrical types.

Cylindrical Type

Cylindrical accumulators consist of a cylinder and piston assembly. End caps are attached to both ends of the cylinder. The internal piston separates the fluid and air/nitrogen chambers. Both the end caps and piston are sealed with gaskets and packings to prevent external leakage around the end caps and internal leakage between the chambers. In one end cap, a hydraulic fitting is used to attach the fluid chamber to the hydraulic system. In the other end cap, an air filler valve is installed to perform the same function as the filler valve installed in the spherical accumulator.

Operation

In operation, the compressed-air chamber is charged to a predetermined pressure, which is somewhat lower than the system operating pressure.

This initial charge is referred to as the accumulator preload.

As an example of accumulator operation, let us assume that the cylindrical accumulator in figure 12-34 is designed for a preload of 1,300 psi in a 3,000 psi system. When the initial charge of 1,300 psi is introduced into the unit, hydraulic system pressure is zero. As air pressure is applied through the air pressure port, it moves the piston toward the opposite end until it bottoms. If the air behind the piston has a pressure of 1,300 psi, the hydraulic system pump will have to create a pressure within the system greater than 1,300 psi before the hydraulic fluid can actuate the piston. Thus, at 1,301 psi the piston will start to move within the cylinder, compressing the air as it moves. At 2,000 psi it will have backed up several inches. At 3,000 psi the piston will have backed up to its normal operating position, compressing the air until it occupies a space less than one-half the length of the cylinder.

When actuation of hydraulic units lowers the system pressure, the compressed air will expand against the piston, forcing fluid from the accumulator. This supplies an instantaneous supply of fluid to the hydraulic system.

Many aircraft have several accumulators in the hydraulic system. There may be a main system accumulator and an emergency system accumulator. There may also be auxiliary accumulators located in various unit systems. Regardless of the number and their location within the system, all accumulators perform the same function—that of storing an extra volume of hydraulic fluid under pressure.

Maintenance

Accumulators should be visually examined for indications of external hydraulic fluid leaks. They should then be examined for external air leaks by brushing the exterior with soapy water, which will form bubbles where the air leaks occur.

The air valve assembly should be loosened to examine the accumulator for internal leaks. If hydraulic fluid comes out of the air valve, the accumulator should be removed and replaced. The overhaul or repair of the accumulator is not a line maintenance function, but it is the responsibility of an intermediate-level activity.

The air preload pressure should be checked after relieving the hydraulic system pressure by operating the wing flaps or other hydraulically actuated unit. The

majority of the accumulators installed in naval aircraft are equipped with air pressure gauges for this purpose. When the accumulator is not equipped with a high-pressure air gauge, you may install one at the air preload fitting for this purpose. The required pressure can be found in the MIM for each aircraft.

The preload pressure may be checked by another method in case the accumulator is not equipped with an air pressure gauge. With the system pressure (as indicated by the cockpit gauge) at the normal operating value, relieve system pressure by operating the wing flaps or another unit slowly. The pressure gauge reading must be watched carefully. The last reading before the indicator needle drops suddenly to zero is accepted as the accumulator preload air pressure.

Before disassembly of any accumulator, ensure that the air preload has been completely exhausted. This may be accomplished by loosening the swivel nut on the air filler valve until all air is out; then remove the valve.

Servicing

The purpose of the hydraulic system accumulator is to store an extra volume of fluid under pressure. The energy stored in an accumulator is used for various purposes, such as the actuation of a unit in the event of normal hydraulic system failure. For example, sufficient energy can be stored in an accumulator for several applications of the wheel brakes.

Most accumulators are installed with an air gauge and a high-pressure air valve mounted on a panel of the structure near the accumulator. Figure 12-35 shows

the brake system accumulator installation used on one type of aircraft. The air valve used in the accumulator installations is usually the same type as that used on shock struts.

To service an accumulator, the hydraulic pressure that is trapped in the accumulator must be relieved. This is accomplished by actuating the units involved. For example, the hydraulic pressure in a brake accumulator may be relieved by applying the emergency brake several times. When the hydraulic pressure is relieved, the accumulator gauge should indicate the air or nitrogen pressure specified for the particular accumulator installation. If the pressure indicated is below the specified pressure, the accumulator must be recharged with dry compressed air or nitrogen.

PRESSURE INDICATORS

Pressure gauges installed in hydraulic and pneumatic systems are used to indicate existing hydraulic and pneumatic pressures, and are calibrated in pounds per square inch. Naval aircraft use both the direct reading gauges and the synchro (electric) type.

Direct Reading Type

Direct reading gauges are used in installations such as accumulators, emergency air bottles, arresting gear snubbers, and brake systems. The gauge is connected directly into units or lines leading from units and become part of the container or system. At these points, the gauge is able to sample existing pressure.

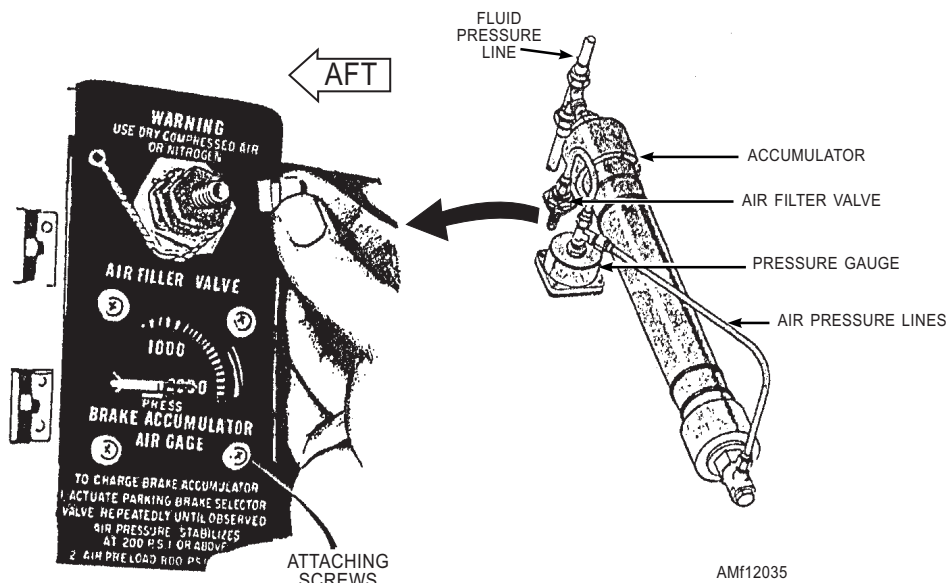

Figure 12-35.—Accumulator air charge valve and gauge installation.

The main part of the direct reading gauge is the Bourdon tube. The Bourdon tube is a curved metal tube that is oval in cross-sectional shape (fig. 12-36). One end of the Bourdon tube is closed, while the other end has a fitting for connecting it to a pressure source. The fitting end is fastened to the gauge frame, while the other end is free to move so it can operate the mechanical linkage.

Assume that fluid pressure enters the Bourdon tube. Since fluid pressure will be transmitted equally in all directions and the area on the outside radius of the tube is greater than that of its inside, the force will also be greater on the outside radius, which tends to straighten the tube. As the movable end of the tube tries to turn outward, it turns the pivot segment gear. This gear meshes with a smaller rotary gear to which a pointer is attached, and its movement causes a reading on the pressure gauge. The gauge dial is calibrated so that the needle points to a number that corresponds to the exact pressure that is applied. When the pressure is removed, the Bourdon tube acts as a spring, and returns to its normal position.

Synchro Type

On most newer aircraft, an electrically operated (synchro) pressure indicator is used. Figure 12-37 shows the pressure indicator of a typical naval aircraft. This aircraft is equipped with three hydraulic systems—No. 1 flight control system, No. 2 flight control system, and utility system. One indicator provides pressure indication for all three systems. This type of arrangement is desirable because it saves instrument panel space.

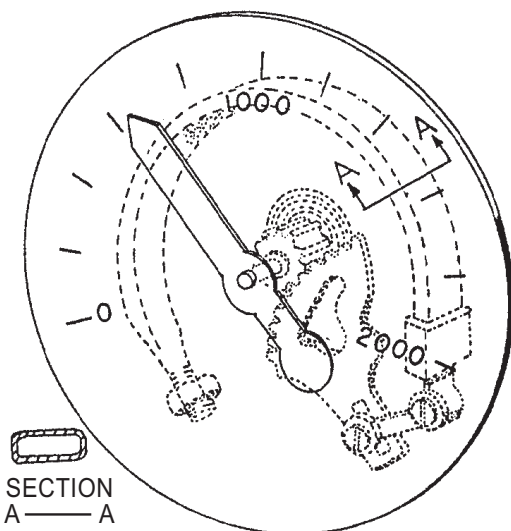

Figure 12-36.—Bourdon tube.

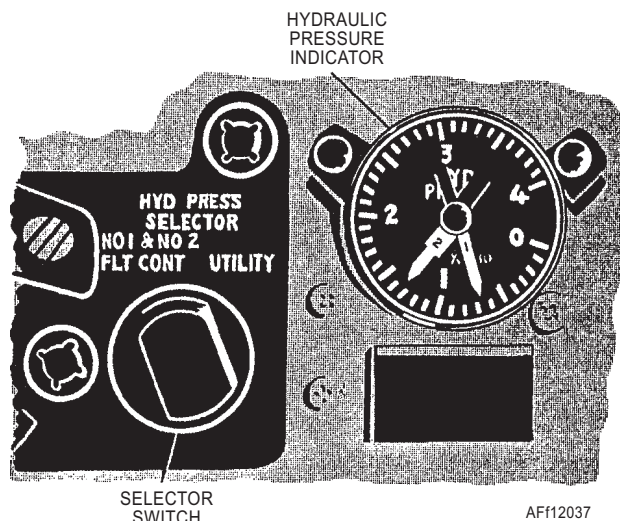

Figure 12-37.—Typical hydraulic pressure indicator.

The indicator system consists of three pressure transmitters, one located in each of the system lines, and a hydraulic pressure selector switch and dual pointer indicator, both located on the pilot's instrument panel.

The transmitters operate on the Bourdon tube principle. Expansion and contraction of the Bourdon tube is transmitted by mechanical linkage to the rotor of a transmitter synchro. The synchro transmits an electrical signal through wiring to the pressure indicator. The indicator contains two synchros mechanically attached to the two separate pointers.

When the HYD PRESS SELECTOR switch (fig. 12-37) is in the No. 1 and No. 2 FLT CONT position, the pointers (marked "1" and "2") indicate the pressure in their respective systems, independent of each other. When the HYD PRESS SELECTOR switch is in the UTILITY position, the synchros are connected in electrical parallel, and the pointers align with each other and act as one.

Although the Aviation Electrician's Mate is responsible for inspecting and maintaining all the aircraft gauges and other instruments, you must know how to read the hydraulic pressure gauge to inspect and maintain the hydraulic system.

Pressure gauges on some naval aircraft are calibrated to register from 0 to 2,000 psi; on others, they register from 0 to 4,000 psi. The gauge in figure 12-37 is an example of the latter type.

As shown in figure 12-37, on gauges designed for a range of 0 to 4,000 psi, the dial is calibrated with four major markings with the numerals 1, 2, 3, and 4. One major intermediate graduation between each numeral and four minor intermediate markings between the

major markings are for reading to the nearest 100 psi. On these gauges, the numeral reading must be multiplied by 1,000 to obtain the actual pressure in psi.

On gauges designed for a range of 0 to 2,000 psi, the dial is calibrated with two major markings, the numerals 1,000 and 2,000, and four intermediate graduations for reading to the nearest 200 psi. A gauge of this type is shown in figure 12-38.

GAUGE AND PRESSURE TRANSMITTER SNUBBERS

A gauge and pressure transmitter snubber is a hydraulic component located upstream of pressure gauges and pressure transmitters. Its purpose is to damper out system pressure surges that could cause possible damage to gauges and pressure transmitters. Snubbers also prevent cockpit hydraulic indicators from oscillating and fluctuating, which makes accurate reading of the gauge not only difficult but often impossible. Without the use of a snubber, pressure oscillations and other sudden pressure changes existing in hydraulic systems could affect the delicate internal mechanism of both gauges and transmitters. This may cause either complete destruction of the gauge or transmitter or, often worse, partial damage, resulting in false readings.

The basic components of a snubber are the housing, fitting assembly with a fixed orifice diameter, and the pin and plunger assembly, as shown in figure 12-39. The snubbing action is obtained by metering fluid through the snubber. The fitting assembly orifice restricts the amount of fluid that flows to the gauge or pressure transmitter, thereby snubbing the force of a pressure surge. The pin is pushed and pulled through the orifice of the fitting assembly by the plunger, keeping it clear and at a uniform size.



Figure 12-38.—Hydraulic pressure gauge.

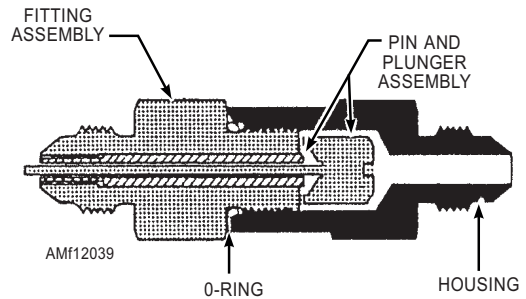

Figure 12-39.—Gauge and pressure transmitter snubber.

EMERGENCY SYSTEMS

According to the military specifications discussed earlier in this chapter, an aircraft may have a standby hydraulic system for emergency operation of the flight controls, a compressed air (pneumatic) system for operating the brakes, and a mechanically operated system for lowering the landing gear. Inspection and maintenance of these systems are also your responsibility.

On aircraft using a standby hydraulic system, the emergency power system components will usually include a reservoir, a pump, and an emergency control in the cockpit for switching from NORMAL to EMERGENCY. Additional components will vary from aircraft to aircraft, depending on the method used for driving the emergency pump.

The emergency system pump may be electric-motor driven, ram-air turbine driven, or it may be hand operated. All three methods are currently used on naval aircraft.

Regardless of the method used in driving the pump, the emergency power system must be completely independent of the normal power system. The normal and emergency lines are usually separated as far apart from each other as practicable. This is done to reduce to a minimum the possibility of both lines being ruptured by a single projectile.

The emergency reservoir is usually located as remotely as practicable from the normal reservoir, but it is generally possible to fill both reservoirs through a common filler port. Usually, the filler port is located on the normal system reservoir.

Operation of Typical Motor-Driven System

A schematic diagram of a typical electric motor-driven emergency power system is shown in figure 12-40. Individual components included in the system are a reservoir, a motor-driven pump, an

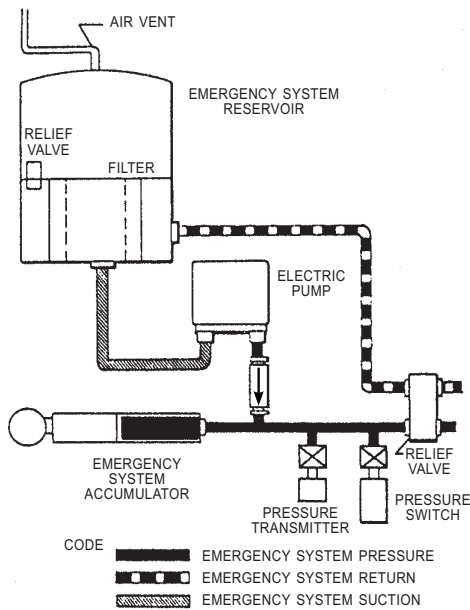

Figure 12-40.—Schematic diagram of typical emergency power system (electric-motor driven).

accumulator, a relief valve, a pressure switch, a snubber, and a control switch in the cockpit.

The main difference in a system of this type and a normal (engine-driven) system is that instead of operating continuously, the pump operates only when pressure is needed in the system. For example, if the normal power system is inoperative, the pilot turns on the emergency system switch in the cockpit. Turning this switch on energizes a pressure switch that is connected into the emergency hydraulic system pressure line. The pressure switch is actuated automatically by hydraulic pressure.

For example, when emergency system pressure drops below a predetermined point, the pressure switch turns the pump motor on. When the pressure builds up to the designed operating psi, the pressure switch turns the pump motor off.

The system is protected from excessive pressures by a relief valve, which is set to open at a pressure slightly above system operating pressure. Emergency power systems of this type are generally equipped with an accumulator for storing a reservoir supply of fluid under pressure. This prevents the pump motor from having to cut in repeatedly to maintain operating pressure in the system.

Ram Air Turbine-Driven System

In this type of emergency hydraulic system, ram air is used to turn the blades of a turbine that, in turn,

operates a hydraulic pump. The turbine and pump assembly is generally installed on the inner surface of a door installed in the fuselage. The door is hinged, allowing the assembly to be extended into the slipstream by pulling a manual release in the cockpit. Figure 12-41 shows a typical ram air unit. This type of emergency system is intended for use only when normal hydraulic pumps are completely inoperative.

Because of differences in system designs, aircraft emergency system operating pressures will differ from one aircraft to another. The ram air turbine system shown in figure 12-41 provides a means for emergency hydraulic and electrical power when the normal aircraft hydraulic system has failed. The turbine-driven hydraulic pump supplies fluid under pressure to the primary flight controls as well as to an emergency hydraulically driven alternator.

The turbine system shown in figure 12-42 consists of a dropout governor-controlled turbine, a hydraulic pump connected in parallel to the normal hydraulic system, a ram air turbine actuator, and a turbine-retract control valve. You can pull the release handle, located in the cockpit within easy reach of the pilot, to operate the system. A mechanical latch releases the turbine assembly into the airstream. The spring-loaded turbine actuator initiates extension of the turbine assembly, and the airstream force completes the extension. During starting and acceleration of the turbine, the turbine blades remain at a constant setting until near maximum rpm. At this point, the governor senses the shaft rpm and begins to vary the blade angle to prevent excessive turbine speed. At this speed, the pump is delivering its maximum amount of fluid. As the turbine slows down, usually due to a decrease in airspeed, the fluid delivery from the pump will also decrease. This type of system allows the aircraft to be controlled in flight by supplying the necessary hydraulic and electrical power.

The turbine is maintained in the fully extended position by a hydraulic lock in the turbine actuator. When the RAM AIR TURBINE RETRACT button switch is depressed, electrical power is supplied to the solenoid-operated turbine retract control valve. Hydraulic pressure from the hydraulic power system is ported to the retract side of the turbine actuator (fig. 12-42) through a restrictor, which controls the retract speed. As the turbine door reaches the closed position, the spring-loaded hook-type lock is cammed up until it drops over the roller, locking the door closed. When the button switch is released, electrical power is removed from the control valve and the retract side of

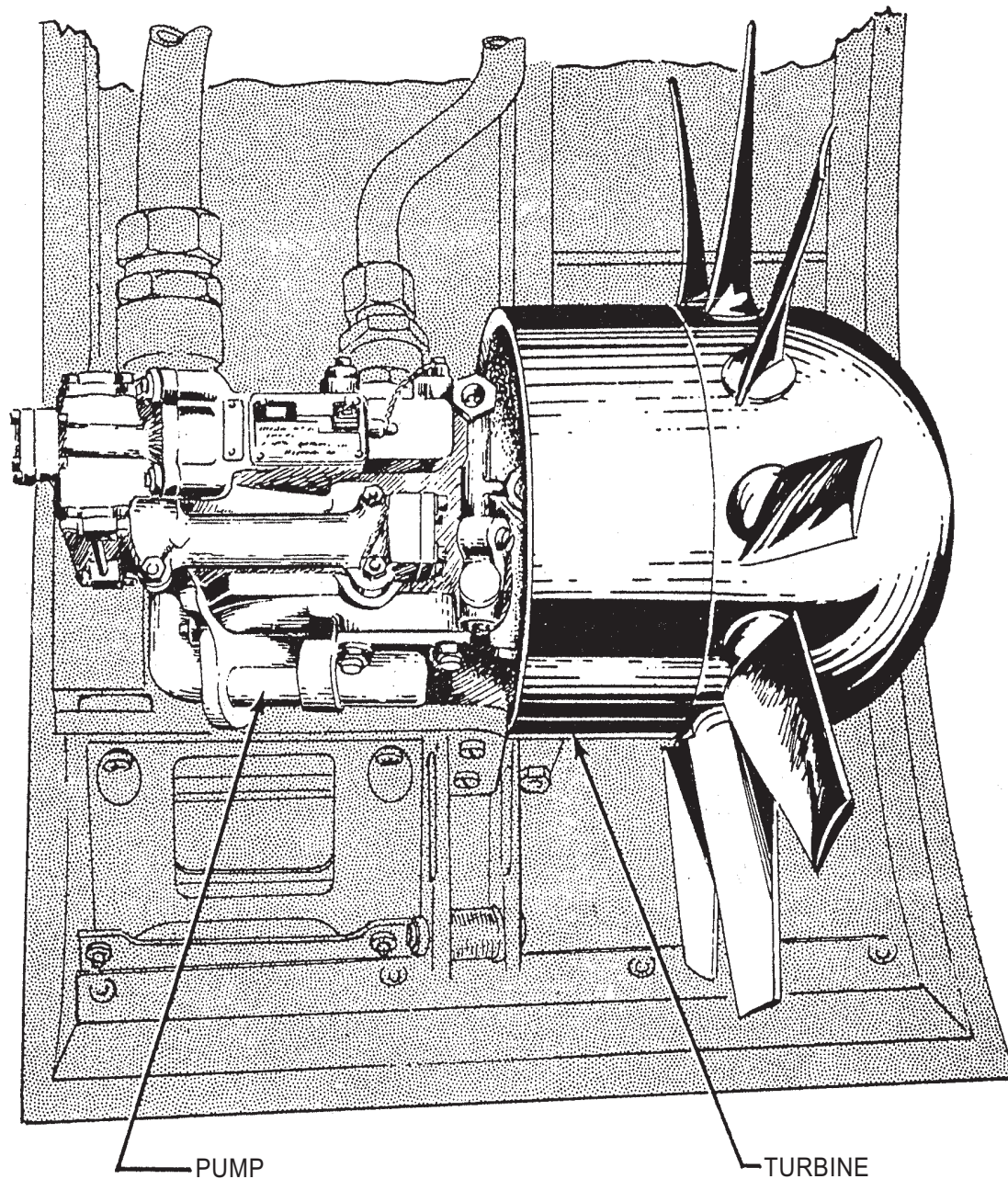

Figure 12-41.—Ram air turbine hydraulic pump assembly.

AMF12041

the actuator is depressurized, thus completing the retract cycle.

Pneumatic System

Two types of pneumatically operated emergency systems are currently used in naval aircraft. One type consists merely of one or more storage cylinders, a control in the cockpit for releasing the contents of the cylinders, a ground charge valve, and the connecting lines and fittings. This type of system must be serviced with compressed air or nitrogen.

The other type of system in current use has its own compressor and other equipment necessary for maintaining an adequate supply of compressed air during flight. Provision for ground charging this type of system is also provided. In addition to a compressor, the components in this type of system usually include a filter, a pressure regulator, a moisture separator, a relief valve, a chemical drier, and storage cylinder(s).

AIR COMPRESSORS.—A typical air compressor is shown in figure 12-43. An installation of this type receives its supply of air from the compressor section of the aircraft engine. This air is

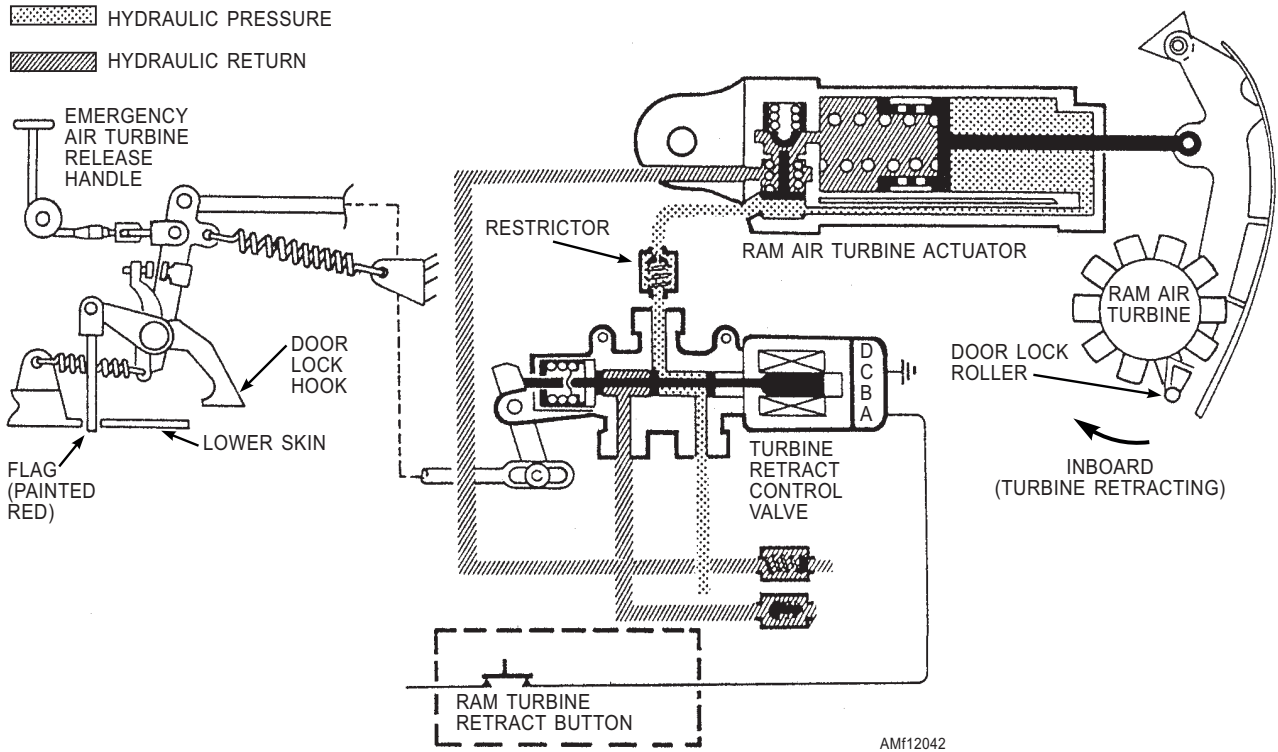

Figure 12-42.—Ram air turbine-control system schematic.

then compressed further to the required pressure for operating the system. Compressors of this type are capable of maintaining up to and above 3,000 psi pressure during flight.

On some aircraft, the compressor is operated by an electric motor. On others, a hydraulic motor is used to drive the compressor. Compressors must be serviced with oil periodically, as outlined in the aircraft MIM. An oil level sight gage is provided on the compressor (fig. 12-43).

AIR FILTERS.—An air filter is usually located in the line leading into the system compressor. Additional filters may be located at various points in the system lines to remove any foreign matter that may enter the system.

Like hydraulic filters, air filters have a removable element and a built-in relief valve. The relief valve is designed to open and bypass the air supply around the filter element should the element become clogged. Some air filters are equipped with the micronic-type element, which must be replaced periodically. Others have the screen mesh type, which requires periodic cleaning. The latter type may be reinstalled after cleaning and drying.

AIR PRESSURE REGULATORS.—A pressure regulator is generally located in the line between the engine compressor and the pneumatic system

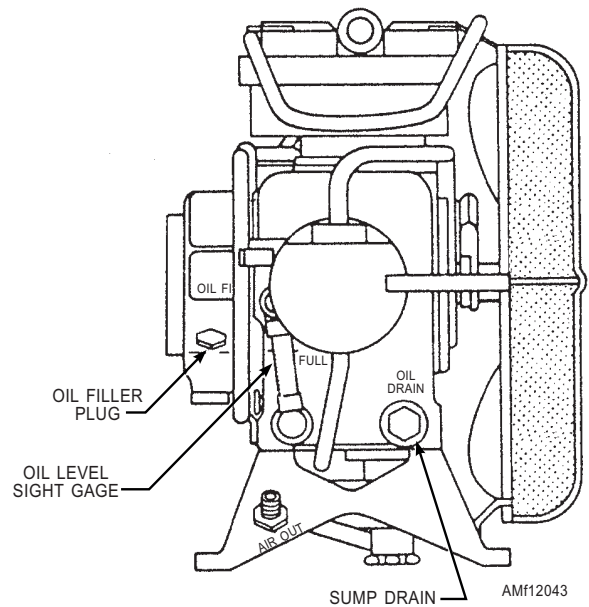

Figure 12-43.—Air compressor.

compressor; however, it may be incorporated within the system moisture separator. Its purpose is to regulate the pressure of the supply air before it enters the system compressor. The pressure regulator maintains a stable outlet pressure regardless of the inlet pressure.

MOISTURE SEPARATORS.—The moisture separator in a pneumatic system is always located downstream of the compressor. Its purpose is to

remove any moisture caused by the compressor. A complete moisture separator consists of a reservoir, a pressure switch, a dump valve, and a check valve, and it may include a regulator and a relief valve. The dump valve is energized and de-energized by the pressure switch. When de-energized, it completely purges the separator reservoir and lines up to the compressor. The check valve protects the system against pressure loss during the dumping cycle and prevents reverse flow through the separator.

RELIEF VALVES.—A relief valve is incorporated in a pneumatic system to protect the system from overpressurization. Overpressurization is generally caused by thermal expansion (heat). Relief valves are generally adjusted to open and close at pressures slightly above normal system operating pressure. For example, in a system designed to operate at 3,000 psi, the relief valve might be set to open at 3,750 psi and reseal at 3,250 psi.

CHEMICAL DRIERS.—Chemical driers are incorporated at various locations in a pneumatic system. Their purpose is to absorb any moisture that may collect in the lines and other parts of the system.

Each drier contains a cartridge, which should be blue in color. If otherwise noted, the cartridge is to be considered contaminated with moisture and should be replaced.

STORAGE CYLINDERS.—Pneumatic storage cylinders (bottles) are made of steel and may be either cylindrical or spherical in shape. Both types of cylinders are made up of two main parts—the container itself and a manifold assembly. The container serves as a trap for moisture, as well as an air storage space. The manifold assembly is made up of the “in” and “outlet” ports and a moisture drain fitting. See figure 12-44.

Cooling of the high-pressure air in the storage cylinders will cause some condensation to collect in them. To ensure positive operation of systems, storage cylinders must be purged of moisture periodically. This is accomplished by slightly cracking the moisture drain fitting, located on the cylinder manifold.

Some aircraft have a pneumatic system that will maintain the required pressure in these bottles in flight. However, most of these pneumatic systems require servicing on the ground with an external source of high-pressure air or nitrogen prior to each flight.

Air storage bottles are serviced in the same manner as accumulators. Most air bottles have an air filler valve and a pressure gauge. These systems generally require higher servicing pressure than accumulators do.

Since gases expand with heat and contract when cooled, air storage bottles are usually filled to a given pressure at ambient temperature. A graph similar to

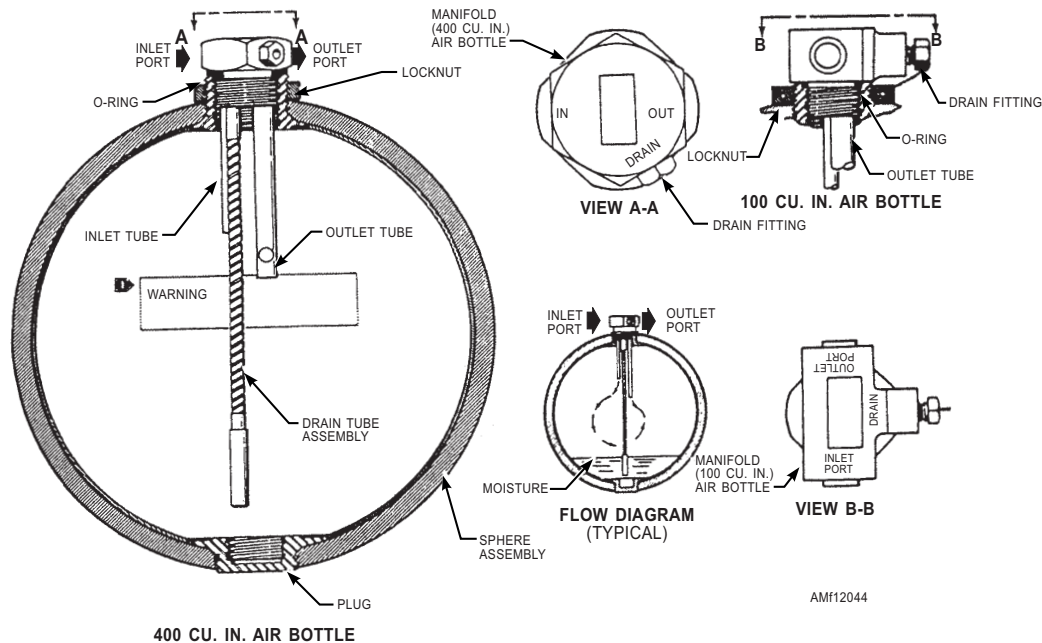

Figure 12-44.—Air cylinder.

that shown in figure 12-45 is usually mounted on a plate or decal on or near the bottle or air filler valve. If the instruction plate is missing or not readable, the information may be found in the General Information and Servicing section of the applicable MIM.

Pressure should be added to air storage bottles slowly in order not to build up heat from rapid transfer. You should take care to ensure that air storage bottles are not overinflated.

- Q12-7. *There are a total of how many classes of hydraulic reservoirs?*
- Q12-8. *The fluid quantity of a nonpressurized reservoir is indicated by a float and arm liquidometer. The liquidometer is operated by what means?*
- Q12-9. *In an air-pressurized reservoir, the fluid quantity is indicated by what means?*
- Q12-10. *Hydraulic systems that require the use of hand pumps are classified as what type of system?*
- Q12-11. *What type of hydraulic pump does not require the use of external pressure regulators or unloading valves?*
- Q12-12. *What type of hydraulic pump is usually driven by a dc wound electric motor?*
- Q12-13. *The piston-type pump (Stratopower variable displacement), Model 65WB06006, rated at 3,000 psi is capable of delivering how many gallons of fluid per minute?*
- Q12-14. *Why are relief valves installed in aircraft hydraulic systems?*
- Q12-15. *To increase the opening pressure of a thermal relief valve, what action must you take?*
- Q12-16. *In a hydraulic system, what is the purpose of the motor-operated shutoff valve?*
- Q12-17. *What is the maximum allowable temperature for any type of military aircraft hydraulic system?*
- Q12-18. *A radiator-type hydraulic fluid cooler uses what medium for cooling?*
- Q12-19. *What component is used to conserve space and provide a means where common fluid lines may come together?*
- Q12-20. *What are the three basic units of a hydraulic filter assembly?*

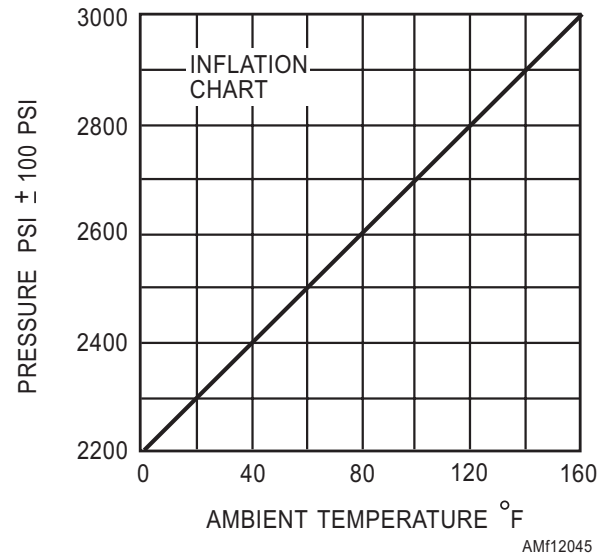

Figure 12-45.—Pneumatic storage cylinder inflation chart

- Q12-21. *What type of noncleanable filter element is used on most naval aircraft?*
- Q12-22. *The differential pressure indicator on a filter assembly is reset by what means once the button is extended?*
- Q12-23. *To prevent fluid loss when the bowl has been removed, most filter assemblies incorporate what item in the head?*
- Q12-24. *How many general types of accumulators are used on naval aircraft?*
- Q12-25. *What is the correct method to preload an accumulator?*
- Q12-26. *To indicate the amount of pressure in a hydraulic system, naval aircraft use what two types of pressure gauges?*
- Q12-27. *What component is used to damper out system pressure surges that could cause possible damage to gauges and pressure transmitters and prevent cockpit hydraulic indicators from oscillating and fluctuating?*
- Q12-28. *What are the three methods currently used for driving emergency system pumps on naval aircraft?*
- Q12-29. *What component initiates extension of the ram-air turbine assembly?*
- Q12-30. *A chemical air dryer cartridge is NOT contaminated when it is what color?*

CHAPTER 13

LANDING GEAR SYSTEMS

INTRODUCTION

Maintenance on the landing gear, at times, requires maintenance of related systems. This chapter covers the general landing gear systems. Also covered are drop checking procedures, troubleshooting, and the alignment and adjustment of the landing gear.

The systems discussed here are representative. For training purposes, we will use many values for tolerances and pressures to illustrate normal operating conditions. When actually performing the maintenance procedures, you must consult the current applicable technical publications for the exact values to be used.

LANDING GEAR SYSTEMS

LEARNING OBJECTIVE: Identify the various types of landing gear used on fixed-wing and rotary-wing aircraft.

Every aircraft maintained in today's Navy is equipped with a landing gear system. Most Navy aircraft also use arresting and catapult gear. The landing gear is that portion of the aircraft that supports the weight of the aircraft while it is on the ground. The landing gear contains components that are necessary for taking off and landing the aircraft safely. Some of these components are landing gear struts that absorb landing and taxiing shocks; brakes that are used to stop and, in some cases, steer the aircraft; nosewheel steering for steering the aircraft; and in some cases,

nose catapult components that provide the aircraft with carrier deck takeoff capabilities.

FIXED-WING AIRCRAFT

Landing gear systems in fixed-wing aircraft are similar in design. Most aircraft are equipped with the tricycle-type retractable landing gear. Some types of landing gear are actuated in different sequences and directions, but practically all are hydraulically operated and electrically controlled. With a knowledge of basic hydraulics and familiarity with the operation of actuating system components, you should be able to understand the operational and troubleshooting procedures for landing gear systems.

Main Landing Gear

The typical aircraft landing gear assembly consists of two main landing gears and one steerable nose landing gear. As you can see in figure 13-1, a main gear is installed under each wing. Because aircraft are different in size, shape, and construction, every landing gear is specially designed. Although main landing gears are designed differently, all main gear struts are attached to strong members of the wings or fuselage so that the landing shock is distributed throughout the main body of the structure. The main gears are also equipped with brakes that are used to shorten the landing roll of the aircraft and to guide the aircraft during taxiing.

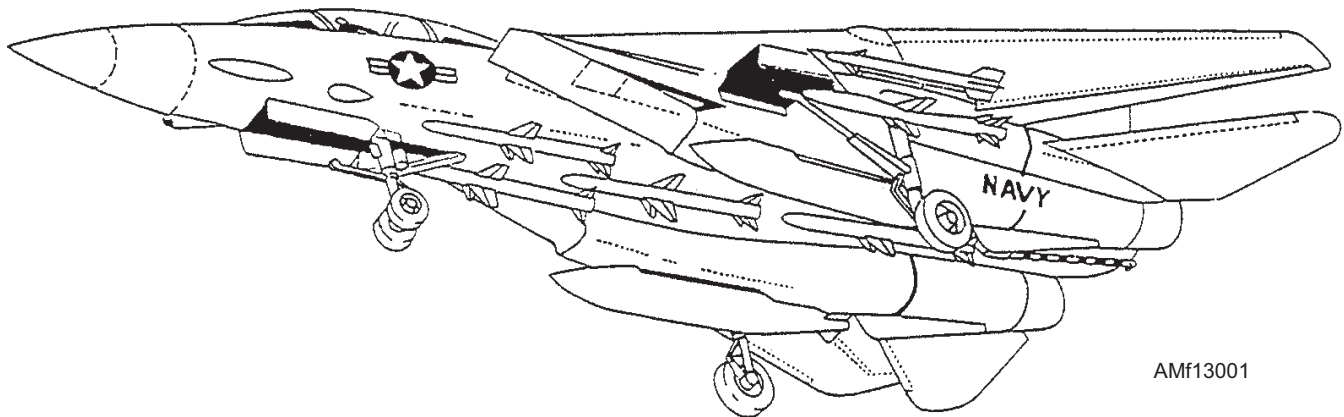

AMf13001

Figure 13-1.—Tricycle landing gear.

Nose Landing Gear

On aircraft with tricycle landing gear, the nose gear is retracted either rearward or forward into the aircraft fuselage. Generally, the nose gear consists of a single shock strut with one or two wheels attached. On most aircraft the nose gear has a steering mechanism for taxiing the aircraft. The mechanism also acts as a shimmy damper to prevent oscillation or shimmy of the nosewheel. Since the nosewheel must be centered before it can be retracted into the wheel well, a centering device aligns the strut and wheel when the weight of the aircraft is off the gear.

ROTARY-WING AIRCRAFT

The landing gear systems on rotary-wing aircraft come in several different designs. A helicopter may have a nonretractable landing gear, such as that found on the H-46 and H-60 helicopters, or it may have a retractable type landing gear like that incorporated on the H-53 helicopter. Some helicopters have a nose landing gear while others have a tail landing gear. The H-53 has a retractable nose landing gear, but the H-46 has the nonretractable type of nose landing gear. The H-60 helicopter uses a tail landing gear. The H-60 tail landing gear is nonretractable.

As you can see, helicopter landing gear systems come in several different configurations. The landing gear systems on most of the helicopters used in the Navy use wheel and brake assemblies. The components used in the landing gear system of a helicopter are very similar to those used in a fixed-wing aircraft landing gear system. In helicopters that use retractable landing gear systems, the components and means of actuation are also similar in design to fixed-wing aircraft. For discussion purposes, we will use the landing gear system of the H-60 helicopter. This helicopter uses a nonretractable main and tail landing gear.

Main Landing Gear

The main landing gear system of the H-60 helicopter consists of nonretractable left and right single wheel landing gear assemblies and the weight-on-wheels system. Each main landing gear assembly is composed of a shock strut, drag beam, axle, wheel, tire, and wheel brake. The left main landing gear assembly also includes a weight-on-wheels sensing switch.

The main landing gear supports the helicopter when it is on the ground, and cushions the helicopter

from shock during landing. The weight-on-wheels switch provides helicopter ground or flight status indications for various helicopter systems.

Tail Landing Gear

The H-60 tail landing gear system consists of a dual-wheel landing gear, tail wheel lock system, and tail bumper.

The tail landing gear is a cantilever type with an integral shock strut. The gear is capable of swiveling 360 degrees. It can be locked in the trail position by the tail wheel lock system. A tail recovery assist, secure, and traverse (RAST) probe is mounted on the tail gear.

Q13-1. A landing gear system is operated and controlled by what means?

Q13-2. What does a typical fixed-wing aircraft landing gear configuration consist of?

Q13-3. In what direction does the nose landing gear of a fixed-wing aircraft retract?

Q13-4. At what time does the centering device of a nose landing gear ensure that the strut and the nose wheel are aligned?

Q13-5. What type of landing gear is found on a H-60 helicopter?

Q13-6. What type of nose landing gear is found on a H-53 helicopter?

Q13-7. On the H-60 helicopter, what landing gear assembly includes the weight-on-wheels sensing switch?

Q13-8. What type of tail landing gear is incorporated on the H-60 helicopter?

LANDING GEAR SYSTEMS OPERATION

LEARNING OBJECTIVE: Identify operational procedures of landing gear systems.

Landing gear systems on naval aircraft, as stated earlier, are similar in design. Most aircraft equipped with the tricycle-type, retractable landing gear have two systems of operation, normal and emergency.

NORMAL SYSTEM

The normal system of a "typical" landing gear system is described because many components used in different landing gear systems are similar. Figure 13-2

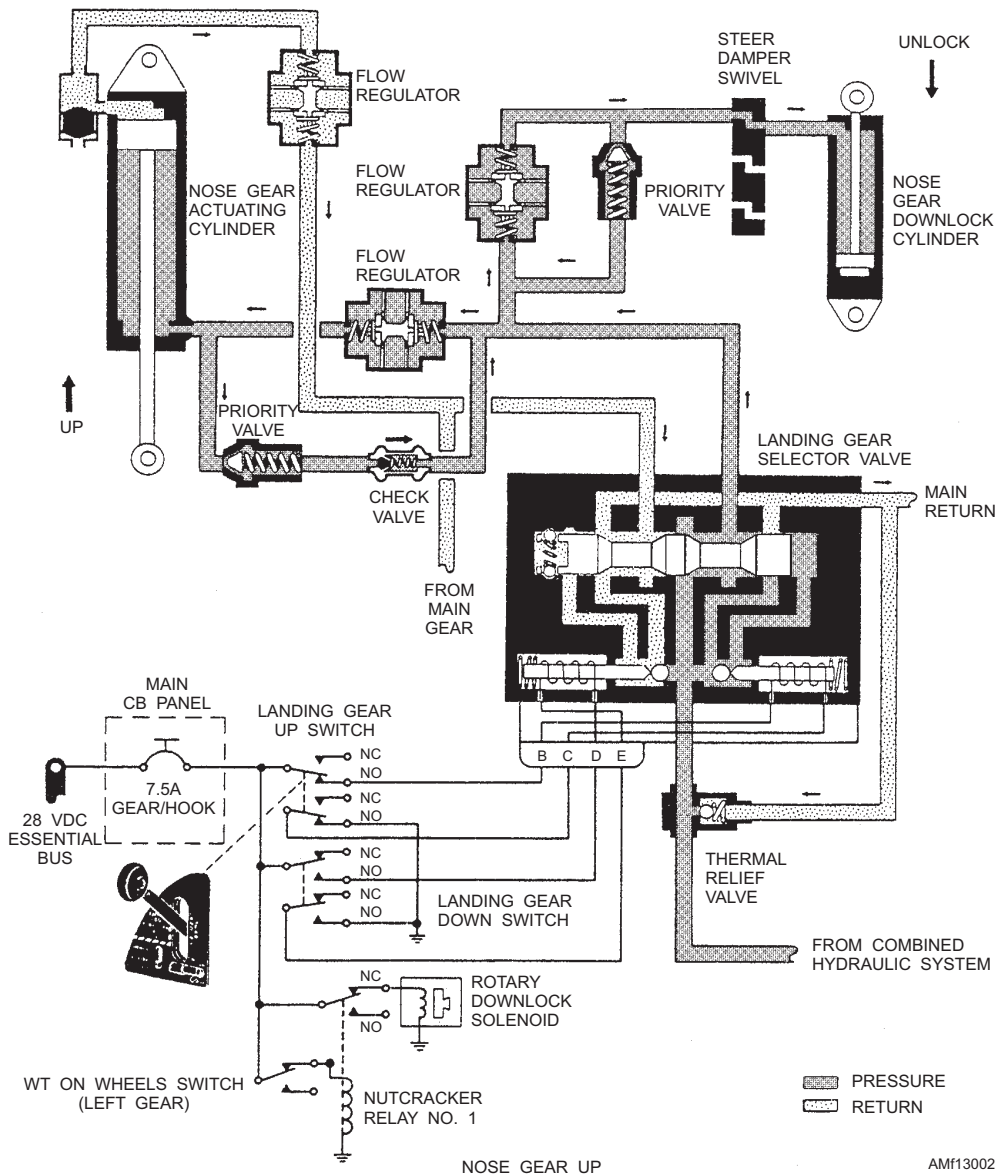

Figure 13-2.—Nose gear up cycle schematic.

is a schematic that shows the fluid flow in the nose gear up cycle. This system contains a selector valve, flow regulators, priority valves, check valve, actuating cylinders, and the necessary hydraulic tubing that routes hydraulic fluid to and from the required components.

When the landing gear handle is in the UP position, a circuit is completed from the landing gear handle circuit breaker, through the landing gear up switch, to the selector valve. The selector valve is electrically positioned to direct pressure into the landing gear up lines and to vent the down lines to return. Fluid flows from the selector valve, through a flow regulator to the up side of the nose gear cylinder. Fluid also flows through another flow regulator to the down lock

cylinder. The down lock cylinder disengages the down lock, and the nose gear cylinder starts to raise the nose gear. As the gear is raised, the nose gear doors are closed by mechanical linkage. When the gear is fully retracted, the up lock mechanism engages the nose gear to lock it in the up position. The up lock mechanism is mechanically actuated through linkage connected to the nose gear.

As soon as the down lock mechanism is disengaged and the gear starts to retract, the pilot's position indicator displays change from a wheel to a barber pole, and the transition light on the landing gear control panel comes on. As soon as the gear is up and locked, the transition light goes out and the position indicator changes from a barber pole to UP, as shown in

figure 13-3. When the landing gear is down and locked, wheels appear on the indicator.

EMERGENCY SYSTEMS







If the landing gear fails to extend to the down and locked position, each naval aircraft has an emergency method to extend the landing gear. Emergency extension systems may vary from one aircraft to another. The methods used may be the auxiliary/emergency hydraulic system, the air or nitrogen system, or the mechanical free-fall system. An aircraft may contain a combination of these systems. For example, the main landing gear emergency extension may be operated by the free-fall method and the nose gear by the auxiliary/hydraulic system method.

The nitrogen storage bottle system is a one-shot system powered by nitrogen pressure stored in four compressed nitrogen bottles. See schematic in figure 13-4. Pushing in, rotating clockwise, and pulling out the landing gear control handle actuates the emergency gear linkage connected to the manually operated release valve on the nitrogen bottle. The release valve connects pressure from the bottle to each release valve of the remaining three bottles. The compressed nitrogen from the manually operated bottle repositions the shuttle valve in each of the other three nitrogen bottles and permits nitrogen pressure to flow to the extend side of the cylinders. When the up lock hooks are released, the main gear drops by gravity, and the nose gear extends by a combination of gravity and nitrogen pressure. Each gear extends until the down

lock secures it in the down position. At this time, the cockpit position indicator shows the down wheel, and the transition light on the control panel goes out. During the emergency extension, cockpit indications on the indicator and the lighting of the transition light are the same as during normal landing gear extension.

When the landing gear control handle is actuated in the emergency landing gear position, a cable between the control and the manually operated nitrogen bottle opens the emergency gear down release valve on the bottle, as shown in the schematic in figure 13-4. Nitrogen from this bottle actuates the release valves on the other three bottles so that they will discharge. Nitrogen flow from the manually operated bottle actuates the dump valves. This action cause the shuttles within the shuttle valve on the aft door cylinders, and on the nose gear cylinder, to close off the normal port and operate the cylinders. The nose gear cylinder extends and unlocks the up lock and extends the nose gear. The nitrogen flowing into the aft door cylinders opens the aft doors. Fluid on the closed side of the door cylinders and the up side of the nose gear cylinder is vented to return through the actuated dump valves. Nitrogen from another bottle actuates the shuttle valves on the up lock cylinders. Nitrogen flows into the up lock cylinders and causes them to disengage the up locks. As soon as the up locks are disengaged, the main gear extends by the force of gravity. Fluid on the up side of the main gear cylinders is vented to return through the actuated dump valves, preventing a fluid lock. When the gear fully extends, the down lock cylinder's spring extends its piston and engages the down lock.

WHEELS TRANSITION LIGHT	
INDICATION	REASON FOR INDICATION
	NOSE GEAR OR EITHER MAIN GEAR NOT FULL DOWN AND LOCKED

MAIN GEAR POSITION INDICATOR		NOSE GEAR POSITION INDICATOR	
INDICATION	REASON FOR INDICATION	INDICATION	REASON FOR INDICATION
DOWN GEAR LEFT NOSE RIGHT 	MAIN GEAR FULL DOWN.	DOWN GEAR LEFT NOSE RIGHT 	NOSE GEAR FULL DOWN.
UP GEAR LEFT NOSE RIGHT 	MAIN GEAR FULL UP.	UP GEAR LEFT NOSE RIGHT 	NOSE GEAR FULL UP.
BARBER POLE GEAR LEFT NOSE RIGHT 	MAIN GEAR IN ANY POSITION OTHER THAN FULL UP OR FULL DOWN.	BARBER POLE GEAR LEFT NOSE RIGHT 	NOSE GEAR IN ANY POSITION OTHER THAN FULL UP OR FULL DOWN.

AMF13003

Figure 13-3.—Landing gear warning and position indicator.

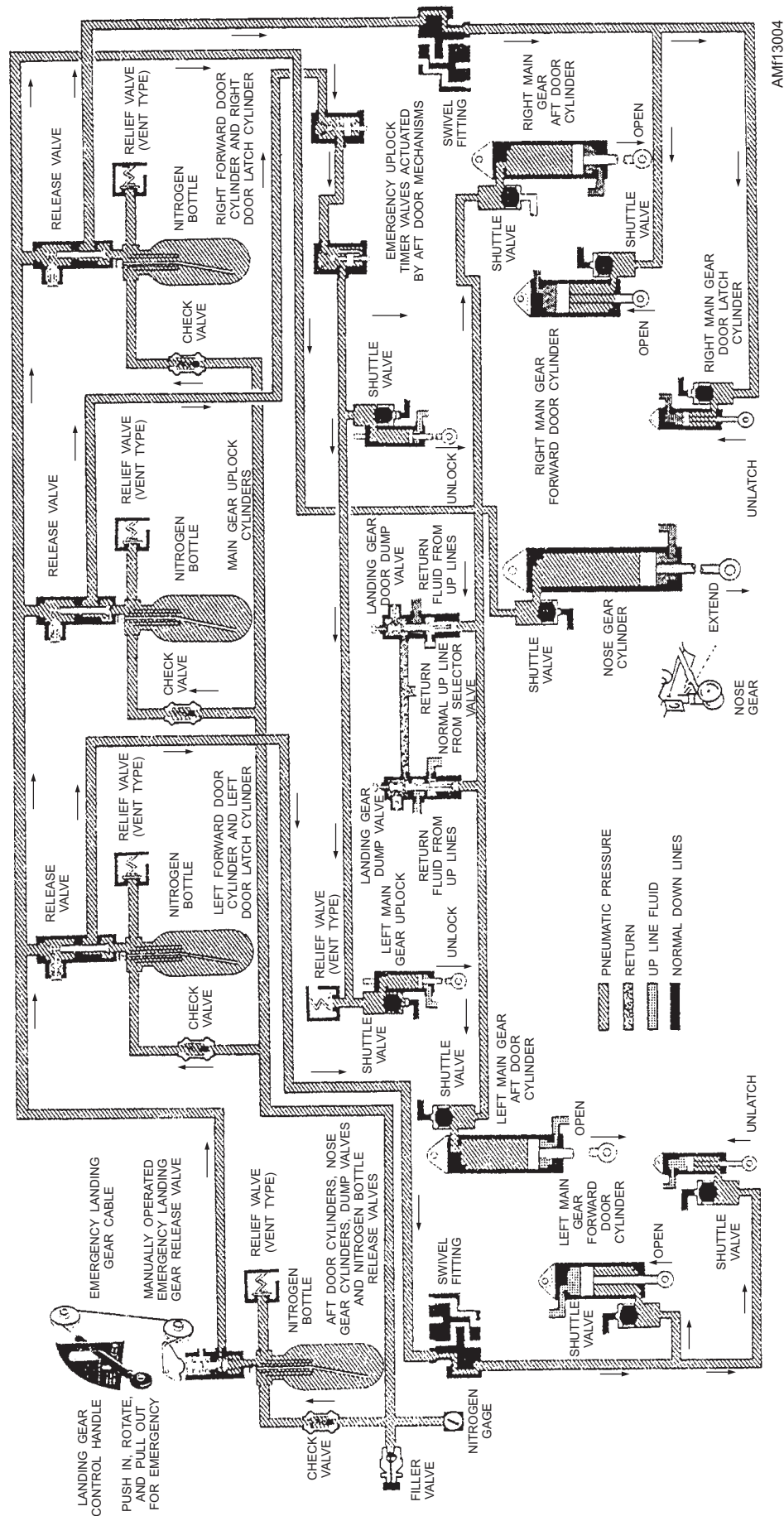

Figure 13-4.—Emergency landing gear extension system.

- Q13-9. During normal operation, what component disengages the down lock, allowing the nose landing gear cylinder to raise the nose gear?
- Q13-10. During normal operation, what component closes the nose landing gear doors?
- Q13-11. What is indicated in the pilot's position indicator when the landing gear is in transition from gear down to gear up?
- Q13-12. In addition to the pilot's position indicator, what other device tells you that the landing gear is in transit from gear down to gear up?
- Q13-13. During emergency operation, what indications are shown on the pilot's position indicator and on the landing gear handle?
- Q13-14. What component of the emergency landing gear system actuates the release valves on three of the four nitrogen bottles?

LANDING GEAR COMPONENTS

LEARNING OBJECTIVE: Identify the components of the landing gear system.

Various mechanical and hydraulic components make up a landing gear system. The components discussed here are representative of those found on most naval aircraft.

LANDING GEAR DOOR LATCHES

Landing gear hydraulic system maintenance is similar to the other types of hydraulic system maintenance. This system is inspected for internal and external leakage as well as proper operation during inspections. While performing operational checks, you must inspect the complete landing gear installation for adjustments, clearances, and sequence of operation.

The adjustment of latches is one of your prime concerns. A latch is used in hydraulic systems as a device designed to hold a unit in a certain designated position after the unit has traveled through a part of its cycle. For example, when the landing gear is retracted in some landing gear systems, each gear is held in the up position by a latch. The same holds true when the landing gear is extended. Latches are also used to hold the landing gear doors in the open or closed positions.

There are many variations in designs of latches. All latches are designed to accomplish the same thing. They must operate automatically, at the proper time, and hold the unit in the desired position.

The main landing gear forward door is held closed by two door latches. As shown in figure 13-5, one latch is installed near the front of the door and the other near the rear of the door. To lock the door securely, both locks must grip and hold the door tightly against the

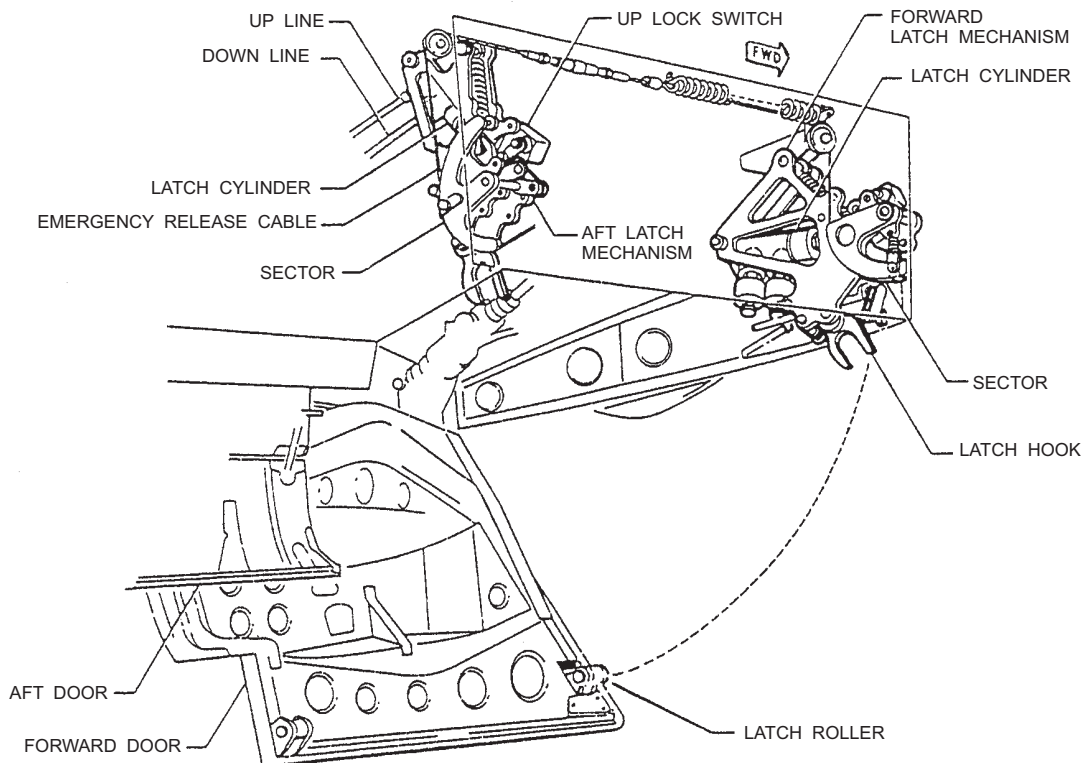

AMf13005

Figure 13-5.—Main gear door latch mechanisms.

aircraft structure. The principal components of each latch mechanism, shown in figure 13-5, are a hydraulic latch cylinder, a latch hook, a spring-loaded linkage, and a sector. The latch cylinder is connected hydraulically with the landing gear control system and mechanically, through linkage, with the latch hook. When hydraulic pressure is applied, the cylinder operates the linkage to engage or disengage the hook with or from the latch roller on the door. In the gear-down sequence, the hook is disengaged by the spring load on the linkage. In the gear-up sequence, spring action is reversed when the closing door is in contact with the latch hook, and the cylinder operates the linkage to engage the hook with the latch roller. Cables on the landing gear emergency extension system are connected to the sector to permit emergency release of the latch rollers. An up-lock switch is installed on, and actuated by, each latch to provide main-gear-up indication in the cockpit.

With the gear up and the door latched, inspect the latch roller for proper clearance. See view B of figure 13-6. On this installation, the required clearance is 1/8 inch \pm 3/32 inch. If the roller is not within tolerance, it may be adjusted by loosening its mounting bolts and raising or lowering the latch roller support. This can be done because of the elongated holes and serrated locking surfaces of the latch roller support and serrated plate. See view A of figure 13-6.

LANDING GEAR DOORS

When installing new landing gear doors, you have to trim each door for a specific installation to obtain the required clearances. The amount of material to be trimmed is determined by retracting the landing gear (with the door linkage disconnected), and then releasing the hydraulic pressure. The up lock rollers on the doors are then removed to allow the doors to be closed, and yet not become locked in the closed position. With the landing gear doors held in the closed position, each door's edge is marked where trimming is needed to maintain the specified clearances. The doors are then opened and the excess amount of material trimmed off. After you have completed the trimming and checked the doors for proper clearances, the landing gear is lowered and the door linkage and up lock rollers are installed.

The distance the landing gear doors open or close depends upon the length of door linkage and adjustment of doorstops. Maintenance instruction manuals (MIMs) specify the length of door linkages and adjustment of stops or other procedures whereby correct adjustments may be made. On some models of aircraft that incorporate forward and aft landing gear doors, the doors are adjusted separately, and in some cases, they are "pulled" or "warped" into a desired shape.

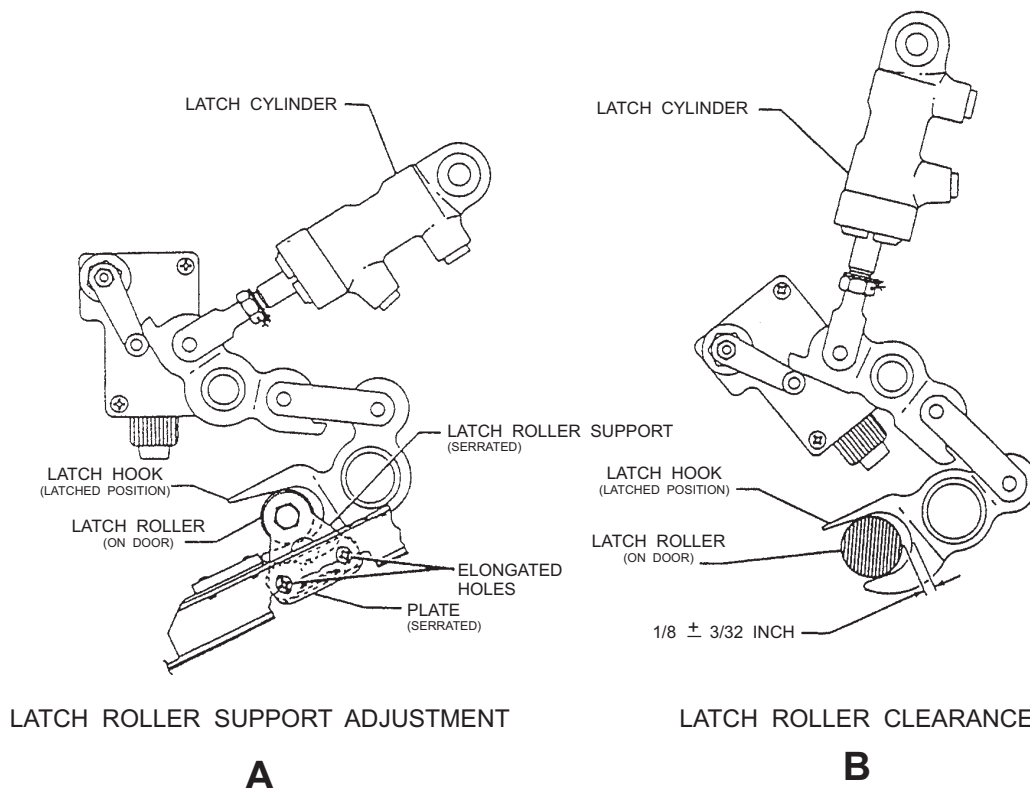

Figure 13-6.—Landing gear door latch installation.

AMf13006

Landing gear doors have specific allowable clearances that must be maintained between doors and the aircraft structure or other landing gear doors. These required clearances can be maintained by adjusting the door hinges and connecting links and trimming excess material from the door if necessary.

On some installations, door hinges are adjusted by placing the serrated hinge and serrated washers in the proper position and torquing the mounting bolts, which allows linear adjustments. Figure 13-7 shows this type of mounting. The amount of linear adjustment is controlled by the length of the elongated bolt hole in the door hinge.

SHOCK STRUTS

Shock struts are self-contained hydraulic units. They carry the burden of supporting the aircraft on the ground and protecting the aircraft structure by absorbing and dissipating the tremendous shock of landing. Shock struts must be inspected and serviced regularly for them to function efficiently. This is one of your important responsibilities.

Each landing gear is equipped with a shock strut. In addition to the landing gear shock struts, carrier aircraft are equipped with a shock strut on the arresting gear. The shock strut's primary purpose is to reduce arresting hook bounce during carrier landings.

Because of the many different designs of shock struts, only information of a general nature will be included in this chapter. For specific information on a particular installation, you should refer to the applicable aircraft MIM or accessories manual.

A typical pneumatic/hydraulic shock strut (metering pin type) is shown in figure 13-8. It uses compressed air or nitrogen combined with hydraulic fluid to absorb and dissipate shock, and it is often referred to as the "air-oil" type strut. This particular strut is designed for use on the main landing gear.

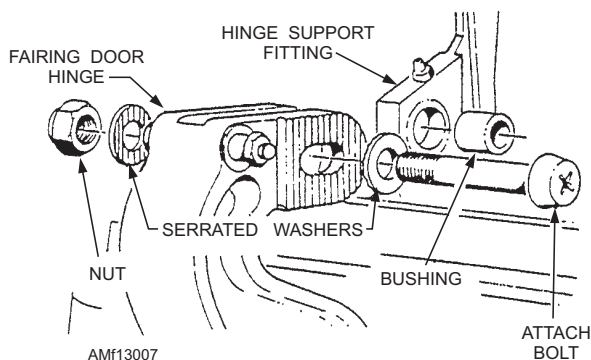

Figure 13-7.—Adjustable door hinge installation.

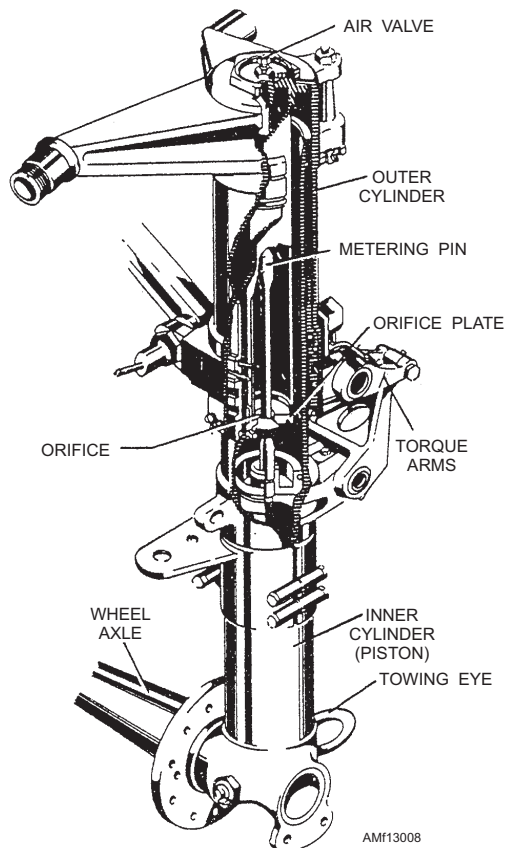

Figure 13-8.—Landing gear shock strut (metering pin type).

The shock strut is essentially two telescoping cylinders or tubes, with externally closed ends. When assembled, the two cylinders, known as cylinder and piston, form an upper and lower chamber for movement of the fluid. The lower chamber is always filled with fluid, while the upper chamber contains compressed air or nitrogen. An orifice (small opening) is placed between the two chambers. The fluid passes through this orifice into the upper chamber during compression, and returns during extension of the strut.

Most shock struts employ a metering pin similar to that shown in figure 13-8 to control the rate of fluid flow from the lower chamber into the upper chamber. During the compression stroke, the rate of fluid flow is not constant, but is controlled automatically by the variable shape of the metering pin as it passes through the orifice.

On some types of shock struts now in service, a metering tube replaces the metering pin, but shock strut operation is the same. An example of this type of shock strut is shown in figure 13-9.

Some shock struts are equipped with a dampening or snubbing device, which consists of a recoil valve on the piston or recoil tube. The purpose of the snubbing device is to reduce the rebound during the extension

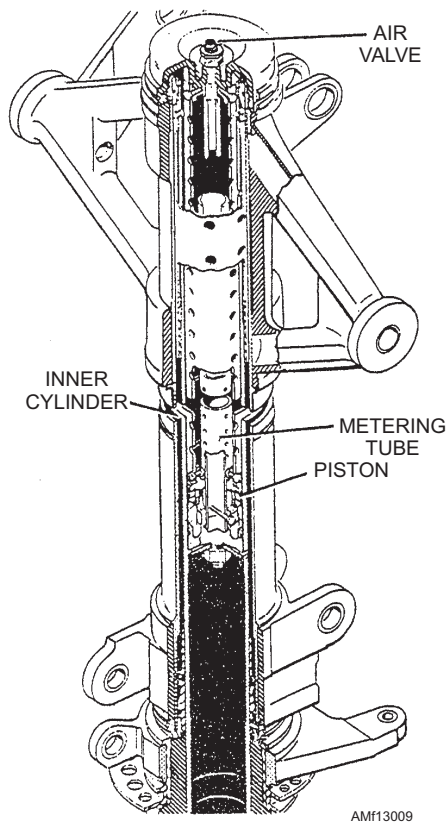

Figure 13-9.—Landing gear shock strut (metering tube type).

stroke and to prevent a too rapid extension of the shock strut, which would result in a sharp impact at the end of the stroke.

The majority of shock struts are equipped with an axle that is attached to the lower cylinder to provide for tire and wheel installation. Shock struts not equipped with axles have provisions on the end of the lower cylinder for ready installation of the axle assembly. Suitable connections are also provided on all shock struts to permit attachment to the aircraft.

A fitting, which consists of a fluid filler inlet and a high-pressure air valve, is located near the upper end of each shock strut to provide a means of filling the strut with hydraulic fluid and inflating it with air or nitrogen.

A packing gland designed to seal the sliding joint between the upper and lower telescoping cylinders is installed in the open end of the outer cylinder. A packing gland wiper ring is also installed in a groove in the lower bearing or gland nut on most shock struts to keep the sliding surface of the piston or inner cylinder free from dirt, mud, ice, and snow. Entry of foreign matter into the packing gland will result in leaks. The majority of shock struts are equipped with torque arms attached to the upper and lower cylinders to maintain correct alignment of the wheel.

Nose gear shock struts are provided with an upper centering cam that is attached to the upper cylinder and a mating lower centering cam that is attached to the lower cylinder. See figure 13-10. These cams serve to line up the wheel and axle assembly in the straight-ahead position when the shock strut is fully extended. This prevents the nosewheel from being cocked to one side when the nose gear is retracted, preventing possible structural damage to the aircraft. These mating cams also keep the nosewheel in a straight-ahead position prior to landing when the strut is fully extended.

Nose and main gear shock struts are usually provided with jacking points and towing lugs. Jacks should always be placed under the prescribed points. When towing lugs are provided, the towing bar should be attached only to these lugs.

All shock struts are provided with an instruction plate that gives, in a condensed form, instructions relative to the filling of the strut with fluid and inflation of the strut. The instruction plate also specifies the correct type of hydraulic fluid to use in the strut. The plate is attached near the high-pressure air valve. It is of the utmost importance that you *always* consult the applicable aircraft MIMs and familiarize yourself with the instructions on the plate prior to servicing a shock strut with hydraulic fluid and nitrogen or air.

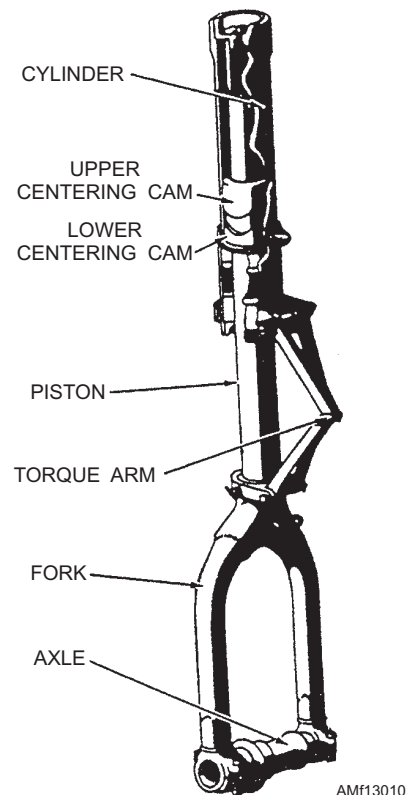

Figure 13-10.—Nose gear shock strut.

Figure 13-11 shows the inner construction of a shock strut and the movement of the fluid during compression and extension of the strut. The compression stroke of the shock strut begins as the aircraft hits the ground. The center of mass of the aircraft continues to move downward, compressing the strut and sliding the inner cylinder into the outer cylinder. The metering pin is forced through the orifice, and by its variable shape, controls the rate of fluid flow at all points of the compression stroke. In this manner,

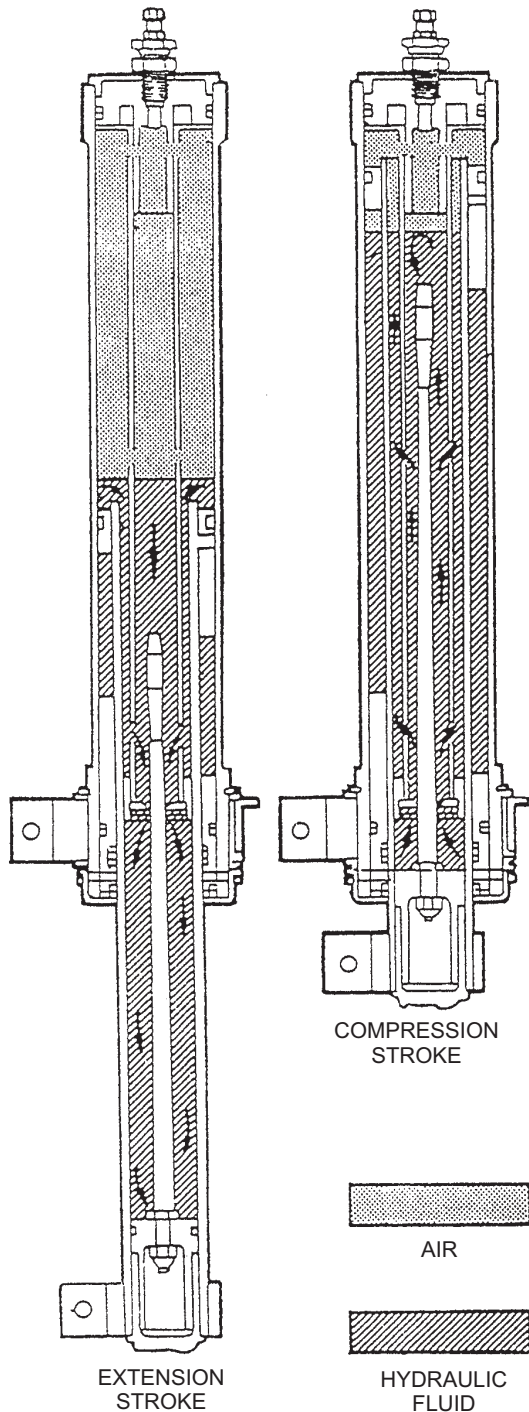

Figure 13-11.—Shock strut operation.

the greatest possible amount of heat is dissipated through the walls of the shock strut. At the end of the downward stroke, the compressed air or nitrogen is further compressed, limiting the compression stroke of the strut. If there is an insufficient amount of fluid and/or air or nitrogen in the strut, the compression stroke will not be limited, and the strut will "bottom" out, resulting in severe shock and possible damage to the aircraft.

The extension stroke occurs at the end of the compression stroke, as the energy stored in the compressed air or nitrogen causes the aircraft to start moving upward in relation to the ground and wheels. At this instant, the compressed air or nitrogen acts as a spring to return the strut to normal. At this point, a snubbing or dampening effect is produced by forcing the fluid to return through the restrictions of the snubbing device (recoil valve). If this extension were not snubbed, the aircraft would rebound rapidly and tend to oscillate up and down because of the action of the compressed air. A sleeve, spacer, or bumper ring incorporated in the strut limits the extension stroke.

MECHANICAL LINKAGE

The landing gear drag brace, shown in figure 13-12 consists of an upper and lower brace that is hinged at the center to permit the brace to jackknife during retraction of the gear. The upper brace pivots on a trunnion attached to the wheel well overhead. The lower brace is connected to the lower portion of the shock strut outer cylinder.

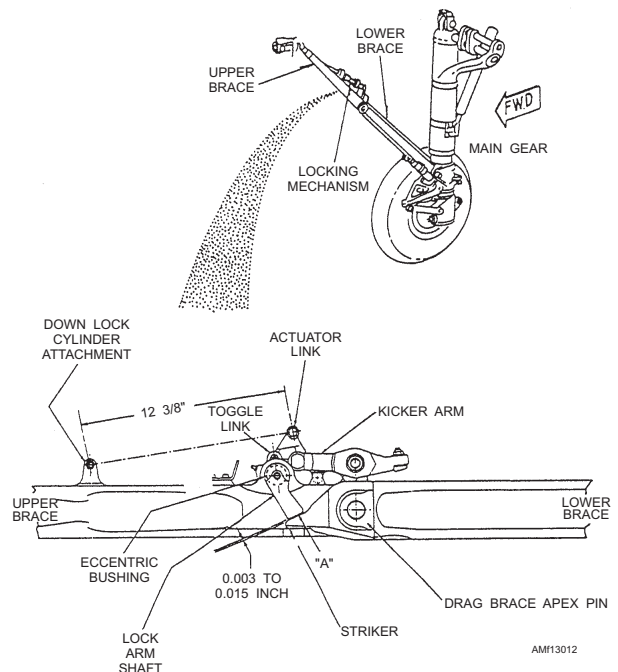

Figure 13-12.—Landing gear drag brace adjustment.

On the drag brace shown in figure 13-12, a locking mechanism is used where the lower and upper drag braces meet. Usually in this type of installation, the locking mechanism is adjusted so that it is allowed to be positioned slightly overcentered. You must be able to inspect and adjust landing gear braces and locking mechanisms as specified in the applicable MIM.

To adjust the drag brace shown in figure 13-12, you would first remove the cotter pin and nut (not shown) from the lock arm shaft. With the drag brace in the full extended position, rotate the eccentric bushings that are located on each end of the lock arm shaft.

Both bushings must be rotated together to ensure that the high point of the eccentricity is the same on both bushings. Failure to do this may result in damage to the equipment or sluggish operation. The bushings may be rotated in either direction until the end of the lock arm shaft, shown as point "A" in figure 13-12, is a distance of 0.003 inch to 0.015 inch from the striker. This clearance is checked with a feeler gauge.

Other portions of the drag brace are nonadjustable, except for the length of its down lock cylinder. Figure 13-12 indicates the cylinder should be adjusted to a length of 12 3/8 inches.

In the design of drag braces, the tendency has been directed toward lessening the adjustment requirements. In some installations, drag braces are manufactured to exact dimensions and do not require adjustments.

Q13-15. What component is used to hold the doors of a landing gear system in the closed position?

Q13-16. What are the principal components of a latch mechanism?

Q13-17. What component provides a main gear up-and-locked indication on the pilot's cockpit indicators?

Q13-18. What is the required clearance for a landing gear door latch roller?

Q13-19. What determines the distance a landing gear door will travel?

Q13-20. A shock struts uses hydraulic fluid and what other substance to absorb and dissipate shock?

Q13-21. What chamber of a metering pin-type shock strut contains the hydraulic fluid?

Q13-22. Where can you find information concerning the correct type of hydraulic fluid to be used in a shock strut?

Q13-23. When does the compression stroke of a shock strut begin?

Q13-24. What part of the shock strut acts like a spring to return the strut to normal?

Q13-25. What component of a landing gear system attaches the upper drag brace to the wheel well?

LANDING GEAR SYSTEMS MAINTENANCE

LEARNING OBJECTIVE: Recognize the procedures for drop checks, troubleshooting, alignment, removal, and replacement of landing gear systems and components.

Mandatory drop checks are required for all landing gear maintenance procedures that involve the removal and replacement of components, breaking of hydraulic lines or fittings, and any adjustments to gear or door linkages. Conditional maintenance requirements cards call for a drop check whenever the aircraft experiences a "hard landing." In addition, regular drop checks are required as part of the aircraft periodic inspection, even if there has been no reported discrepancy.

DROP CHECK PROCEDURES

All drop check operations should be performed as specified in the applicable maintenance instructions manual (MIM). These procedures should be thorough enough to ensure that the system is free of leaks and the operational integrity of the system has been restored following maintenance. Operational checks cover three distinct areas. They are the operation of the landing gear and doors, the operation of the landing gear position indicator and warning system, and the operation of the landing gear emergency system.

The first step in the drop check procedures is to place the aircraft on jacks.

Further preparation includes connection of a hydraulic test stand and external electrical power, removal of landing gear maintenance safety locks, and the proper placement of the landing gear control handle.

As the operational procedure begins, check to make sure that the landing gear doors do not close in the path of the retracting main struts. This condition will be obvious (with hydraulic and electrical power on the aircraft) if the landing gear doors do not remain in the

full open position when the landing gear control handle is placed in the UP position. Placing the landing gear control handle momentarily to the UP and DOWN positions several times will correct this condition by removing air from the wheel door cylinders.

Regulate the hydraulic test stand to operate at a flow of 4 gpm, (gallons per minute) and slowly increase hydraulic pressure. The landing gear down lockpins should start to retract. They should be fully retracted when the pressure reaches 1,800 psi, and then all gear assemblies should start to retract.

When the nose gear nears the up position, be sure the fairing doors are cammed to the closed position, and then check all gear doors to be sure they are closed and locked when the position indicator indicates the up-and-locked condition. Move the landing gear handle down and check to see that the wheel fairing doors open and gear assemblies extend. Visually check all gear assemblies to ensure they are down and locked. With the test stand regulated to 3 gpm at 3,000 psi, the gear should make a complete cycle (up and down) in 12 to 14 seconds. The maximum pressure required to retract and lock the gear is 1,800 psi at 4 gpm.

When you check the emergency extension of the gear, first retract the gear normally, secure external hydraulic pressure, place the landing gear handle in the down position, and then pull and hold the emergency extension handle fully aft. Visually check that all gear assemblies are down and locked by observing the landing gear position indicator in the cockpit, and then release the emergency extension handle. It may be necessary to manually push the gear assemblies to the down-and-locked position. The force required to push the main gear to the locked position should not exceed 20 pounds applied to the axle hub. The force required to push the nose gear to the locked position should not exceed 10 pounds applied at the center line of the axle hub. Make at least one complete normal cycle of the landing gear, and then remove external power and aircraft from jacks.

NOTE: Some aircraft require resetting of the landing gear dump valves before recycling the landing gear. Refer to the applicable MIMs.

TROUBLESHOOTING

Troubleshooting of the landing gear system, like all hydraulic systems, requires that you understand the theory of operation of the particular system and the function and sequence of operation for each component.

Troubleshooting steps provided in the MIM are normally aligned with the sequence of events or steps in the operational checkouts. They provide an efficient means of isolating the malfunction. The MIM requires that each step in the operational checkouts be performed in sequence. If trouble occurs during the procedure, it must be corrected before proceeding with the next step. These troubleshooting aids provide a logical cause for many anticipated landing gear malfunctions, including procedures for isolating and remedying the problem. Refer to the system schematic for the particular system and accompanying maintenance instructions, in addition to sound reasoning, to pinpoint the cause for a malfunction in an efficient manner.

Some landing gear malfunctions are related to improper maintenance practices, with the lack of proper lubrication being the predominant malpractice. A review of past discrepancies and previous corrective actions may also aid in analyzing malfunctions.

Occasionally, discrepancies that are reported as a result of flight are difficult or even impossible to duplicate on the deck. However, too many discrepancies signed off with "Could not duplicate system checks 4.0," or similar corrective actions, show up as repeat malfunctions or as the cause of accidents. Every effort should be made to locate a sound logical cause for a reported malfunction by thoroughly checking the system, each component, linkages, clearance, and associated indicating systems. All phases of the operational checkouts must be verified by a quality assurance inspector.

Detecting internal leakage of components may require the use of special equipment, such as the ultrasonic leak detection translator or simple isolation of components by disconnecting lines, applying pressure, and measuring for allowable leakage limits.

ALIGNMENT AND ADJUSTMENT

Improper rigging or adjustment of landing gear linkages results in a significant number of unsafe or hung landing gear discrepancies. Most landing gear, when in an overcenter and locked position (up or down), requires very little interference or binding to prevent its initial movement.

Alignment of newly installed landing gear assemblies or individual components should be in strict accordance with the procedures outlined in the applicable MIM. Complete assemblies are aligned in a specified sequence, with designated steps throughout

the sequence that require quality assurance verification before proceeding to the next step. Landing gear doors may have to be deactivated or disconnected to check for proper up lock actuation and gear up clearances. Complete alignment includes down-and-locked adjustment, up-and-locked adjustment, and proper door operation. Verification of the emergency landing gear system operation is normally required in verifying the landing gear system. Some MIMs cover the emergency system as a separate procedure, but a complete operational checkout should include the emergency backup system.

WARNING

Ensure that all personnel involved in landing gear maintenance are clear of the landing gear and doors and that signals between the person in the cockpit and the crew leader are clearly understood before raising or lowering the landing gear. Failure to do so could result in personnel injury.

RECOIL STRUT MAINTENANCE

According to current maintenance directives, maintenance of recoil struts (including minor repair and miscellaneous parts replacement) should be confined to work that can be performed with only partial disassembly of the equipment. Instructions for major or complete overhaul are covered in overhaul instructions manuals for recoil struts, and such work is performed by specialized shops.

LOWER STRUT AND GLAND SEAL REPLACEMENT

On most aircraft the piston O-rings and delta rings can be replaced at the organizational level of maintenance while the strut is installed on the aircraft. Procedures for replacing the seals in a main gear recoil strut at the organizational level of maintenance consist of jacking the aircraft in accordance with the applicable MIM. Remove the wheel and brake assemblies so that handling of the lower strut is easier. Remove the cap from the strut filler valve and release the nitrogen pressure from the strut by opening the valve swivel nut counterclockwise. Remove the necessary wire bundles, hydraulic lines, etc., that form a connection between the upper cylinder and lower piston of the strut. Remove the up and down lines from the gear actuating cylinder. Connect a hand pump or check and fill stand lines so that the strut may be retracted to an angle that will allow the piston to be withdrawn from the cylinder. Cap any loose lines or fittings to prevent contamination. On some aircraft, you will have to use a spring compressor or some other means to release tension on the gear down lock mechanism so that the gear can be partially retracted.

With the strut cylinder secured in the partially retracted position and all pressure released from the strut, the upper and lower torque arms can be disconnected. Cut the lockwire and remove the lock screws from the gland nut. Figure 13-13 shows a main gear recoil strut piston. Refer to figure 13-13 while you read the following seal replacement material.

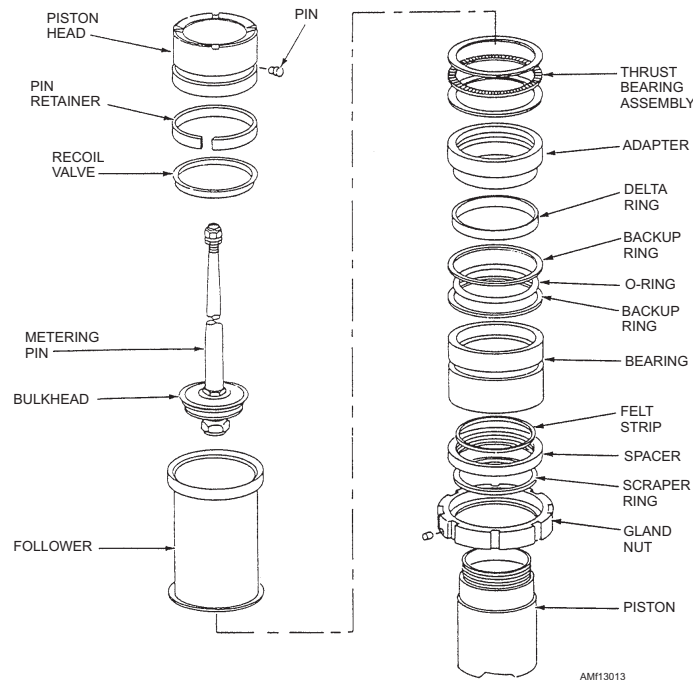

Figure 13-13.—Main gear recoil strut piston.

With the piston supported, the collar or gland nut is unscrewed and the piston withdrawn from the cylinder. Pour the hydraulic fluid into a suitable container, and place the piston/axle assembly in a clean work area. Inspect the hydraulic fluid for evidence of rubber or metal particles that might indicate wear conditions within the strut.

Remove the pin retainer and three pins from the piston head; then remove the piston head and the recoil valve. On some aircraft the retaining pins are press fitted while on others they are screwed in. Remove the metering pin assembly, follower, thrust bearing assembly, adapter, delta ring, and other removable parts in the order in which they are installed on the piston assembly, as shown in figure 13-13.

The cylinder walls, piston head, adapter, follower, and bearings should be inspected for excessive wear and sharp edges. Minor nicks, scratches, or sharp edges can be polished out with a crocus cloth (steel parts) or aluminum oxide abrasive cloth (aluminum parts).

Coat all seals and backup rings with hydraulic fluid and install in the reverse order of the disassembly sequence. Ensure that the adapter, follower, and recoil valve are facing in the right direction on the piston assembly. Once the piston assembly is reassembled, quality assurance should check for proper reassembly before inserting it into the cylinder.

The inner surface of the cylinder and the outer surface of the piston are coated with hydraulic fluid, and the piston is immediately installed in the cylinder. The gland nut is tightened and the lock screws installed and safety wired. The torque arms are reconnected and the strut lowered to its normal extended position. All linkage, hydraulic lines, wire bundles, and the brake and wheel assemblies are installed in the reverse order of their removal. The strut is serviced as required by the applicable MIM or maintenance requirements card.

Proper servicing is very important. Not all struts are serviced in the standard manner. Consult the appropriate MIM to prevent improper servicing and subsequent landing gear or structural failure. All linkage on the lower strut that was disturbed must be lubricated, the brakes bled, and the brakes and the landing gear systems operationally tested.

STRUT REMOVAL AND REPLACEMENT

To remove a strut assembly, first jack the aircraft according to instructions furnished in the applicable MIM. To reduce the weight and allow for easier

handling, remove the wheel (with tire and brake assembly).

CAUTION

Before removing a wheel assembly from an aircraft, deflate the tire completely. To ensure positive removal of all pressure from the tire, you should remove the valve core and attach a "deflated tire" tag to the valve stem after deflating the tire.

Remove all attached fairings and door connecting rods. Disconnect and cap the hydraulic brake lines and fittings. Disconnect electrical connections at the cannon plugs, and remove wiring from clamps as necessary. Retain all removed hardware in a cloth bag.

Disconnect the drag brace by partially pulling the upper torque arm pin. After disconnecting the drag brace, reinstall the pin and nut to retain the torque arm.

The side brace is generally removed with the strut assembly. It should be disconnected at its upper end by removing the nut and pin. After the side brace is disconnected, reinstall the pin.

If equipped with a shrink rod, disconnect the shrink rod from the strut, not from the aircraft. This is accomplished by removing the rod fitting bolt at the bottom of the rod. When the shrink rod is disconnected, the nut and bolt should be reinstalled in the fitting for safekeeping.

Support the recoil strut and partially pull the crossbolt at the top of the strut to disengage it from the support structure. Lower the strut and reinstall the bolt and nut.

Installation essentially reverses the removal procedures. With the aircraft still on jacks, carefully move the top of the recoil strut into place to engage the support structure fitting. Install the crossbolt, washer, nut, and cotter pin. Connect the shrink rod to the shrink rod fitting. Connect the side brace to the support structure fitting. Partially pull the upper torque arm pin and connect the drag brace. Reinstall the pin, tongued washer, nut, and cotter pin.

Assemble the brake and wheel to the strut axle, bleed the brake, and service the strut as specified in the aircraft MIM. Ensure that the air valve is safety wired before charging the strut with nitrogen. After the strut has been serviced with hydraulic fluid and nitrogen, tighten the air valve to the specified torque value required by the MIM. Replace all removed fairings,

doors, hydraulic lines, and electrical connections. Lubricate all reinstalled linkages, and check the landing gear for proper operation.

SERVICING, BLEEDING, AND INSPECTING SHOCK STRUTS

For efficient operation of shock struts, the proper fluid level and pneumatic pressure must be maintained. Before you check the fluid level, you should consult the aircraft MIM. Deflating a strut can be a dangerous operation unless the servicing personnel are thoroughly familiar with high-pressure air valves and observe all the necessary safety precautions.

Servicing

The high-pressure air valve shown in figure 13-14 is used on most naval aircraft. This air valve is used on struts, accumulators, and various other components that must be serviced with high-pressure air or nitrogen.

The following procedures for deflating a typical shock strut, servicing with hydraulic fluid, and reinflating is for instructional purposes only. See figure 13-15. For specific aircraft, consult the appropriate aircraft MIM.

1. Position the aircraft so that the shock struts are in the normal ground operating position. Ensure that personnel, workstands, and other obstacles are clear of the aircraft.

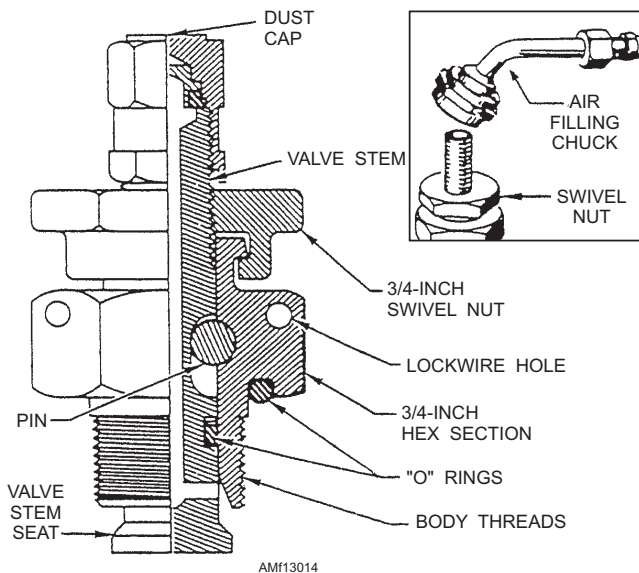

Figure 13-14.—High-pressure air valve, type MS 28889.

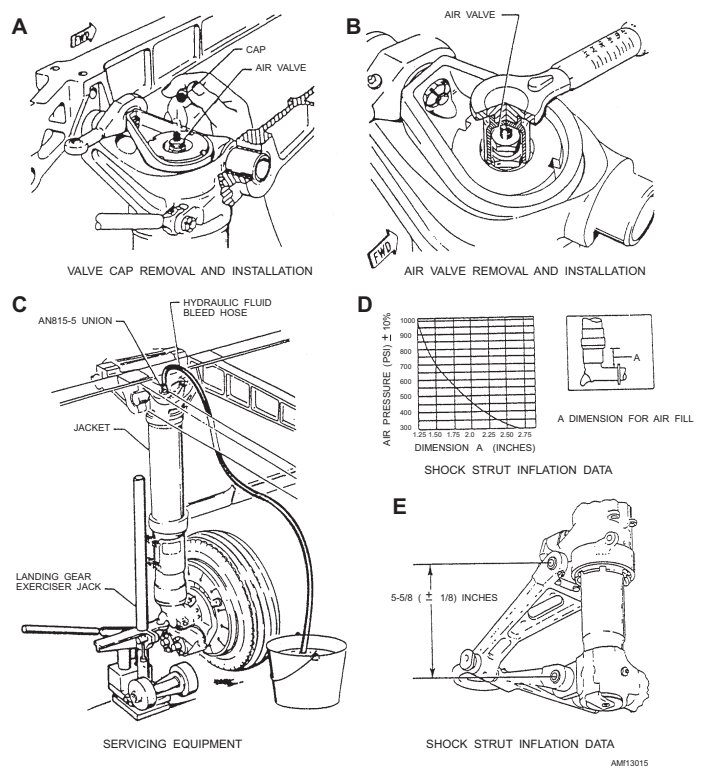

Figure 13-15.—Servicing a landing gear strut.

NOTE: Some aircraft must be placed on jacks with their struts completely extended for servicing.

2. Remove the cap from the air valve, as shown in view A of figure 13-15.

3. Release the air pressure in the strut by slowly turning the air valve swivel nut counterclockwise approximately 2 turns. This action can normally be accomplished with the use of a combination wrench.

WARNING

When loosening the swivel nut, ensure that the 3/4-inch hex body nut is either lockwired in place or held tightly with a wrench. If the swivel nut is loosened before the air pressure has been released, serious injury may result to personnel.

4. Ensure that the shock strut compresses as the air or nitrogen pressure is released. In some cases, it may be necessary to rock the aircraft after deflating to ensure complete compressing of the strut.

5. When the strut is fully compressed, the air valve assembly may be removed by breaking the safety wire and turning the 3/4-inch body nut counterclockwise.

6. Use the type of hydraulic fluid specified on the shock strut inspection plate to fill the strut to the level of the air valve opening. Figure 13-16 shows the instruction plate found on one type of aircraft main landing gear strut. Improper oil level in the strut chamber will decrease the shock absorbing capabilities of the strut and could cause the strut to bottom out during landing. This would damage the strut and/or wing structure.

NOTE: The instruction plate may be found on the strut or on the wheel door near the strut.

7. Reinstall the air valve assembly, using a new O-ring packing. Torque the air valve body hex nut from 100 inch-pounds to 110 inch-pounds, as shown in view B of figure 13-15.

8. Lockwire the air valve assembly to the strut, using the holes provided in the body nut.

9. Inflate the strut, using a regulated high-pressure source of nitrogen or dry air. Under no circumstances should any type of bottle gas other than nitrogen or compressed air be used to inflate shock

struts. The amount a strut is inflated depends upon the specific aircraft strut being serviced. One manufacturer may use a strut inflation chart, such as the one shown in view D of figure 13-15. The strut is measured as indicated at dimension "A." This measurement, in inches, is then located on the bottom of the inflation chart. For example, locate the measurement of 1.75 inches on the chart. From this point, vertically trace an imaginary line until it intersects the curved line. At this point of intersection, horizontally trace a second imaginary line to the left edge of the chart. The figure indicated at this point (550 psi) is the required pressure for that particular extension of the strut.

All aircraft struts are not measured from the same points. View E of figure 13-15 shows another location where strut extension is measured. The proper procedure to use will always be found on the instruction plate attached to the shock strut. If these instructions are not legible, consult the applicable MIM.

If the strut's chamber is underpressurized, the strut may not overcome normal O-ring friction during extension on takeoff. This condition could prevent the strut from fully extending, thus the torque scissors limit switch would not actuate to close the electrical circuit to retract the gear. It would also cause the strut to bottom during taxiing and landing operations.

AEROL

M.F.D. BY
THE CLEVELAND PNEUMATIC TOOL CO.
DIVISION OF CLEVELAND PNEUMATIC
INDUSTRIES INC, CLEVELAND, OHIO, USA
FOR GRUMMAN AIRCRAFT ENGINEERING CORP.
BETHPAGE, LONG ISLAND, N.Y., USA

SERIAL NO. _____ ORDER NO. _____

TYPE _____ DESIGN NO. _____

SPECIFICATION NO. _____

TO CHECK FLUID LEVEL

1. REMOVE VALVE CAP FROM HIGH PRESSURE AIR VALVE (MS 28889-1).
2. SLOWLY DISCHARGE ALL AIR BY TURNING SWIVEL NUT (TURN COUNTERCLOCKWISE) NOTE: RATE OF DISCHARGE IS ESTABLISHED BY AMOUNT SWIVEL NUT IS LOOSEND.
3. REMOVE COMPLETE AIR VALVE ASSEMBLY AND FILL STRUT WITH MIL-H-5606 (RED COLOR) TO LEVEL OF FILLER HOLE WITH STRUT IN NORMAL GROUND POSITION.
4. REPLACE COMPLETE AIR VALVE ASSEMBLY AND TIGHTEN BODY TO 100-110 IN. LBS. TORQUE AND REPLACE LOCKWIRE THEN INFLATE STRUT. SEE "TO INFLATE STRUT".
5. REPLACE AND TIGHTEN VALVE CAP.

TO INFLATE STRUT

1. REMOVE VALVE CAP AND ATTACH AIR FILLER CHUCK TO HIGH PRESSURE AIR VALVE.
2. LOOSEN SWIVEL NUT (TURN COUNTERCLOCKWISE) A MAX OF 2 1/2 TURNS AND INFLATE STRUT USING AN 8286-2 PRESSURE GAGE ADJUST PRESSURE IN ACCORDANCE WITH INFLATION INSTRUCTIONS.
3. TIGHTEN SWIVEL NUT TO 30-70 IN. LBS. TORQUE (TURN CLOCKWISE) REMOVE AIR FILLER CHUCK, CHECK FOR LEAKS AND REPLACE VALVE CAP.

INFLATION INSTRUCTION

REGARDLESS OF AIRCRAFT WEIGHT AND STRUT FRICTION, IF STRUT DIMENSION "X" IS MEASURED AND PRESSURE GIVEN IN THE TABLE TO THE LEFT, DOES NOT CORRESPOND TO THAT IN STRUT, AIR SHOULD BE ADDED OR REMOVED AS REQUIRED.

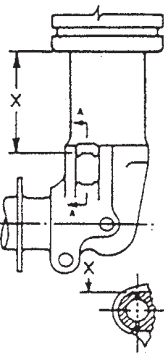

STRUT EXT. DIM. X FULLY EXT.	P. S. I.
6 1/4	388
6 1/8	387
6	408
5 7/8	414
5 3/4	423
5 5/8	432
5 1/2	442
5 3/8	452
5 1/4	463
5 1/8	474
5	485
4 7/8	496
4 3/4	510
4 5/8	524
4 1/2	538
4 3/8	553
4 1/4	568
4 1/8	584
4	603
3 7/8	617
3 3/4	641
3 5/8	663
3 1/2	685
3 3/8	710
3 1/4	735
3 1/8	763
3	792
2 7/8	823
2 3/4	859
2 5/8	899
2 1/2	939
2 3/8	985
2 1/4	1034
2 1/8	1092
.2	1150
1 7/8	1222
1 3/4	1295
3/4	2897

FULLY COMP

Figure 13-16.—Landing gear strut servicing instruction plate.

If the strut's chamber is overpressurized, the additional pressure will tend to keep the strut pressurized after takeoff. On those aircraft that use shrink mechanisms, the shrink mechanisms may be overloaded or stall the strut actuator as the gear retracts. If the gear retracts in the wing without shrinking, due to the failure of the shrink mechanism, damage to both the wing and landing gear may result.

10. Tighten the air valve swivel hex nut to a recommended torque of 50 to 70 inch-pounds.

11. Remove the high-pressure air-line chuck and install the valve cap fingertight.

Because some aircraft struts require special servicing procedures, the General Information and Servicing section of the applicable MIM should always be checked before servicing the shock struts of any aircraft.

Bleeding

If the fluid level of a shock strut has become extremely low or, if for any other reason, air is trapped in the strut cylinder, it may be necessary to bleed the strut during the servicing operation. Bleeding is performed with the aircraft placed on jacks. In this position, the shock struts can be extended and compressed during the filling operation, expelling all of the entrapped air. As mentioned earlier, certain aircraft must be placed on jacks for routine servicing of the shock struts. The following is a typical bleeding procedure.

1. Construct a bleed hose that contains a fitting suitable for making an airtight connection to the shock strut filler opening. The hose should be long enough to reach from the shock strut filler opening to the deck when the aircraft is on jacks.

2. Jack the entire aircraft until all shock struts are fully extended.

3. Release the air or nitrogen pressure in the strut to be bled, as previously described in this chapter.

4. Remove the air filler valve assembly.

5. Fill the strut to the level of the filler port with hydraulic fluid.

6. Attach the bleed hose to the filler port, and insert the opposite end of the hose into a quantity of clean hydraulic fluid.

7. Place an exerciser jack or other suitable single-base jack under the shock strut jacking point. See view C of figure 13-15. Compress and extend the

strut fully (by raising and lowering the jack) until the flow of air bubbles from the strut has completely stopped.

NOTE: Compress the strut slowly and allow it to extend by its own weight.

8. Remove the exerciser jack, and then lower and remove all other jacks.

9. Remove the bleed hose from the shock strut.

10. Install the air filler valve and inflate the strut.

Inspection

Shock struts should be inspected regularly for leakage of fluid and for proper extension. Exposed portions of the strut pistons should be cleaned in the same manner as actuating cylinder pistons during preflight and postflight inspections. Exposed pistons should be inspected closely for scoring and corrosion. Excessive leakage of fluid can usually be stopped by deflating the strut and tightening the packing gland nut. If leakage still persists after tightening the packing gland nut and reinflating the strut, the strut must be disassembled and the packings replaced.

The tools shown in figure 13-17 are typical of the tools used during disassembly and assembly of landing gear shock struts. Normally, each tool is designed for, and should be used only on, one type of installation. When using wrenches, you must take care to maintain the lugs of the wrenches in their respective positions. Slippage of the wrench, when under torquing conditions, may cause damage to aircraft parts, the tool, or even injury to personnel. NEVER place extension handles of any type on these tools to increase the applied force.

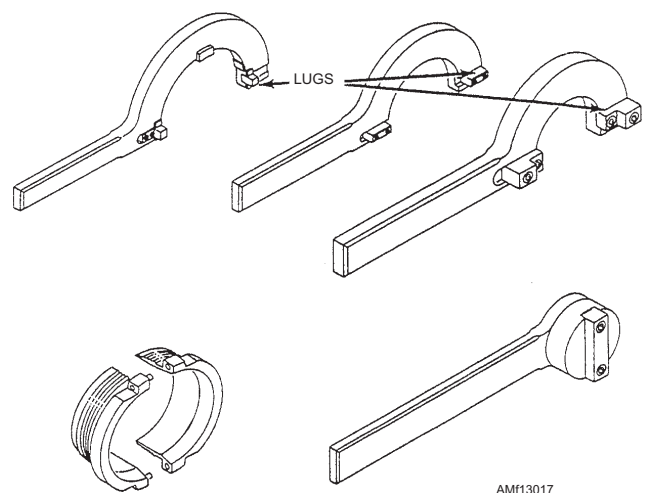

Figure 13-17.—Landing gear shock strut tools.

These tools, like other special tools, should be kept where they will not be subjected to rough handling, which could cause mushroomed or deformed surfaces, making them useless for aircraft repair.

INTERMEDIATE MAINTENANCE REPAIR AND SEAL REPLACEMENT

Repair of recoil struts at the intermediate level of maintenance is restricted to seal replacement and replacement of parts listed in the "Intermediate Maintenance Section" of the aircraft MIM or the appropriate 03 manual. The following paragraphs provide information on the disassembly, cleaning, inspection, parts replacement, reassembly, and bench testing of a strut at the intermediate level.

Disassembly

Disassemble the strut assembly in the order of the key index numbers assigned to the exploded view illustration provided in the appropriate 03 series accessories manual or the "Intermediate Maintenance Section" of the applicable MIM.

WARNING

Before beginning disassembly, make sure that all pressure has been exhausted from the strut. Do not disassemble the inner and outer cylinder until all the pressure has been released from the strut. Disassembly of the strut before releasing all pressure could lead to serious personnel injury or loss of life.

Remove the complete air valve assembly by breaking the lockwire and unscrewing the 3/4-inch hex nut. Turn the strut over and drain the hydraulic fluid. Disconnect the torque arms (scissors). Break the lockwire and unscrew the packing nut at the bottom of the outer cylinder. Carefully withdraw the inner cylinder from the outer cylinder. Pull the metering pin and bulkhead from the inner cylinder with a smooth controlled force. Tag or keep parts together to expedite reassembly.

Cleaning

Thoroughly clean all parts of the recoil strut assembly, using MIL-PRF-680 dry-cleaning solvent (spray or dip) or a similar cleaning solvent. Dry thoroughly with clean, dry, compressed air, paying particular attention to all recesses and internal

passages. Use the cleaning solvent in a well-ventilated area. Avoid prolonged inhalation of fumes. Keep solvent away from open flames.

Cleaned parts that normally come in contact with fluid during operation of the strut should be coated with hydraulic fluid. Depending on local conditions, it may be desirable to also coat external highly machined surfaces.

Wipe the lower bearing clean with a clean, lint-free cloth dampened with hydraulic fluid. Do not touch machined surfaces with your bare hands. Do not use compressed air to dry bearings. Clean the bearings with new cleaning solvent and dry with a lint-free cloth.

Inspection

Perform a thorough visual inspection of the disassembled parts for serviceability. Packing grooves and surrounding areas should be inspected for scratches, burrs, nicks, or other roughness that might cut packings on installation or cause seal failure during strut operation. Inspect machined surfaces for marks, abrasions, gouges, grooves, scores, scratches, and corrosion. If any parts are suspected of having cracks, the part should be inspected using one of the nondestructive methods of testing.

Check all threaded parts for distorted or mutilated threads. Inspect plated surfaces for blistering, flaking, wear, or other defects.

Within the limits of practicability, check all holes for concentricity and taper, using an internal micrometer, hole gauges, plug gauges, or similar equipment. Check the angle between the piston and the axle. Check to ensure that the brake flange is perpendicular to the axle. Inspect all ports, bores, and passages for cleanliness. Place bearings next to a sensitive compass to check for residual magnetism.

Bearings should be inspected for obvious damage, Brinelling (shallow indentations in the raceway), or corrosion. Rotate bearing races and check for roughness, binding, or looseness. Bearing retainers must be checked for cracks, warpage, and corrosion. Refer to the tables furnished in the applicable accessories manual or the "Intermediate Maintenance Section" of the appropriate MIM for service limits established for critical areas.

Repair or Replacement

Repair or replace all parts that show evidence of excessive wear, scoring, or corrosion. Replace all parts

that show wear beyond the dimensions specified in the inspection standards tables found in most O3 manuals or MIMs.

Each time the strut is disassembled, all preformed and special packings should be replaced, although they may appear to be serviceable.

NOTE: Never work on machined surfaces with metallic tools. Always use brass O-ring tools for checking scratches and removing or replacing seals and gaskets.

Blend out minor scratches, nicks, and burrs from machined surfaces of steel parts with a crocus cloth. Use aluminum oxide abrasive cloth to polish aluminum parts. The smoothness of the repaired area must be equal to or smoother than the finish of the surrounding area. Do not attempt to remove normal wear marks from the sliding surface of the piston.

NOTE: Partial removal of plating from the inner cylinder will condemn the part from further service, pending replating of the cylinder. Portable brush-type plating equipment is available in some intermediate maintenance activities for touch-up plating of minor areas.

Areas with damaged paint or other protective finishes must be restored to a serviceable condition.

If any bushings require replacement, the mating bushing must also be replaced.

Reassembly

Reassemble the strut assembly in essentially the reverse order of disassembly. Exercise adequate precautions to ensure that dirt, dust, grit, or other foreign matter does not enter the strut during assembly. Contamination of parts can cause a definite failure. Guarding against contamination cannot be over-emphasized.

Observe the torque values specified in the O3 manual or MIM. Where a specific torque value is not specified for a threaded part, tighten the part according to the standard torque values provided in the *Structural Hardware Manual*, NAVAIR 01-1A-8. Some structural repair manuals and maintenance instructions manuals also contain this information. On some parts, such as the strut gland nut, tightening should conform to acceptable shop practices and common sense, unless otherwise specified.

Lightly coat all preformed packings with hydraulic fluid. After all seals and parts are properly installed, the

piston head is tightened and the retaining pins installed and staked into place. The piston assembly is inserted into the outer cylinder, and the gland nut is tightened to a snug fit, backed off two key slots, and locked in place. If the gland nut is too tight, it will result in binding of the thrust bearing. Two lock plates, positioned 180 degrees apart on the collar and gland nut, are secured with screws and lockwired to hold the gland nut in place. Use the double twist method of applying the lockwire so that tension of the wire tends to tighten the nut.

Bench Testing

With the strut fully compressed and in the vertical position, service the strut with hydraulic fluid. Install the air valve on the strut and torque to 100-110 inch-pounds. Place the strut fully extended in a horizontal or vertical position and inflate with dry nitrogen to the normally extended pressure specified in the MIM or O3 manual. Ensure that the strut shows no leakage after a 1-hour interval.

If the strut fails the bench test, it is tagged to show the portion of the test that failed. Then it is deflated, flushed with preservative hydraulic fluid, and forwarded to the next higher level of maintenance.

If the strut passes the bench test and is not to be installed on an aircraft immediately, flush with preservative hydraulic fluid before sending it to supply.

If any parts other than those listed as replaceable at the intermediate level of maintenance are faulty, tag the strut and forward it to the next higher level of maintenance. The VIDS/MAF is closed out to account for man-hours expended in attempting repairs before the strut is declared beyond the capability of maintenance (BCM). If a Quality Deficiency Report (QDR) form was attached to the strut by the removing organizational maintenance activity, complete the QDR and submit it according to the instructions provided in OPNAV Instruction 4790.2 (series).

Any unusual failure or strut malfunction should be reported by the submission of a QDR so that failure trend patterns or isolated instances may be reviewed for possible higher echelon action. Forward the No. 4 copy of the MAF and the hard copy of the QDR with the strut to the next higher level of maintenance.

Q13-26. All drop checks should be performed in accordance with what manual?

Q13-27. What is the first step in performing a drop check?

- Q13-28. What is the maximum pressure required to retract and lock a landing gear during a drop check?*
- Q13-29. The force applied to the axle hubs to push a landing gear into the down and locked position should not exceed what force?*
- Q13-30. What device can be used to detect internal leakage of a landing gear hydraulic component?*
- Q13-31. Other than normal servicing and removal and replacement, what other type of maintenance can be performed on a shock strut at the organizational level?*
- Q13-32. After the aircraft is on jacks, what is the next step in removing a shock strut?*
- Q13-33. What type of air valve is used on most naval aircraft?*
- Q13-34. How many turns and in what direction must you turn an air valve swivel nut to release the strut pressure?*
- Q13-35. What is the proper torque for installing an air valve on a shock strut?*
- Q13-36. In what position does a shock strut need to be before it can be bled?*
- Q13-37. When should the exposed piston of a shock strut be cleaned?*
- Q13-38. Excessive leaking of fluid from a shock strut can usually be fixed by what method?*
- Q13-39. What is the first step in disassembling a shock strut once it is removed from the aircraft?*
- Q13-40. When bench testing a rebuilt shock strut, it must not leak when filled with nitrogen for how long?*

CHAPTER 14

BRAKE SYSTEMS

INTRODUCTION

Three types of brake systems are currently in use on naval aircraft. They are the independent-type brake system, the power boost brake system, and the power brake control valve system. In addition, there are several different types of brake assemblies currently in use.

TYPES OF BRAKE SYSTEMS

LEARNING OBJECTIVES: Identify the three major brake systems. Recognize the operation of the emergency brake system.

The three major types of brake systems are the independent, power boost, and power brake control valve system.

INDEPENDENT-TYPE BRAKE SYSTEM

In general, the independent-type brake system is used on small aircraft. This type of brake system is termed *independent* because it has its own reservoir and is entirely independent of the aircraft's main hydraulic system.

The independent-type brake system is powered by master cylinders similar to those used in the conventional automobile brake system. However, there is one major difference—the aircraft brake system has two master cylinders while the automobile system has only one.

An installation diagram of a typical independent-type brake system is shown in figure 14-1. The system is composed of a reservoir, two master cylinders, and mechanical linkage, which connects each master cylinder with its corresponding brake pedal, connecting fluid lines, and a brake assembly in each main landing gear wheel.

Each master cylinder is actuated by toe pressure on its related pedal. The master cylinder builds up pressure by the movement of a piston inside a sealed fluid-filled cylinder. The resulting hydraulic pressure is transmitted to the fluid line, which is connected to

the brake assembly in the wheel. This action results in the friction necessary to stop the wheel.

When the brake pedal is released, the master cylinder piston is returned to the OFF position by a return spring. Fluid that was moved into the brake assembly is then pushed back to the master cylinder by a piston in the brake assembly. The brake assembly piston is returned to the OFF position by a return spring in the brake.

The typical master cylinder has a compensating port or valve that permits fluid to flow from the brake chamber back to the reservoir when excessive pressure is developed in the brake line due to temperature changes. This feature ensures against dragging or locked brakes.

Various manufacturers have designed master cylinders for use on aircraft. All are similar in operation, differing only in minor details and construction. Two types of master cylinders, the Goodyear and the Gladden, are described here.

Goodyear Master Cylinder

A cutaway view of the Goodyear master cylinder is shown in figure 14-2. Fluid is fed by gravity to the master cylinder from an external reservoir. The fluid enters through the cylinder inlet port and compensating port and fills the master cylinder casting ahead of the piston and the fluid line leading to the brake actuating cylinder.

Application of the brake pedal, which is linked to the master cylinder piston rod, causes the piston rod to push the piston forward inside the master cylinder casting. A slight forward movement blocks the compensating port, and the buildup of pressure begins. This pressure is transmitted to the brake assembly.

When the brake pedal is released and returns to the OFF position, the piston return spring pushes the front piston seal and the piston back to full OFF position against the piston return stop. This action again clears the compensating port. Fluid that was moved into the brake assembly and brake connecting line is then pushed back to the master cylinder by the brake piston

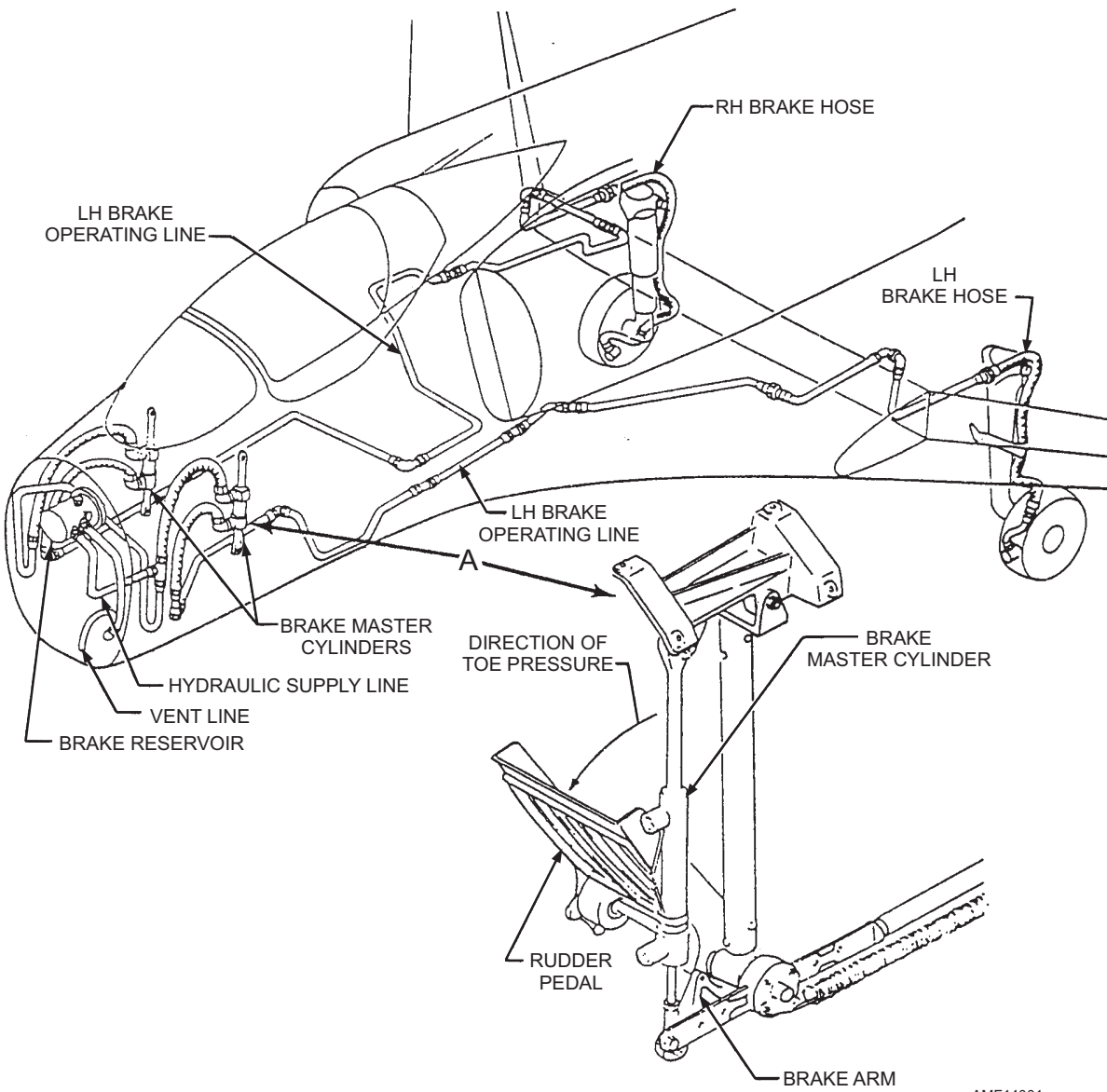

AMF14001

Figure 14-1.—Typical independent-type brake system.

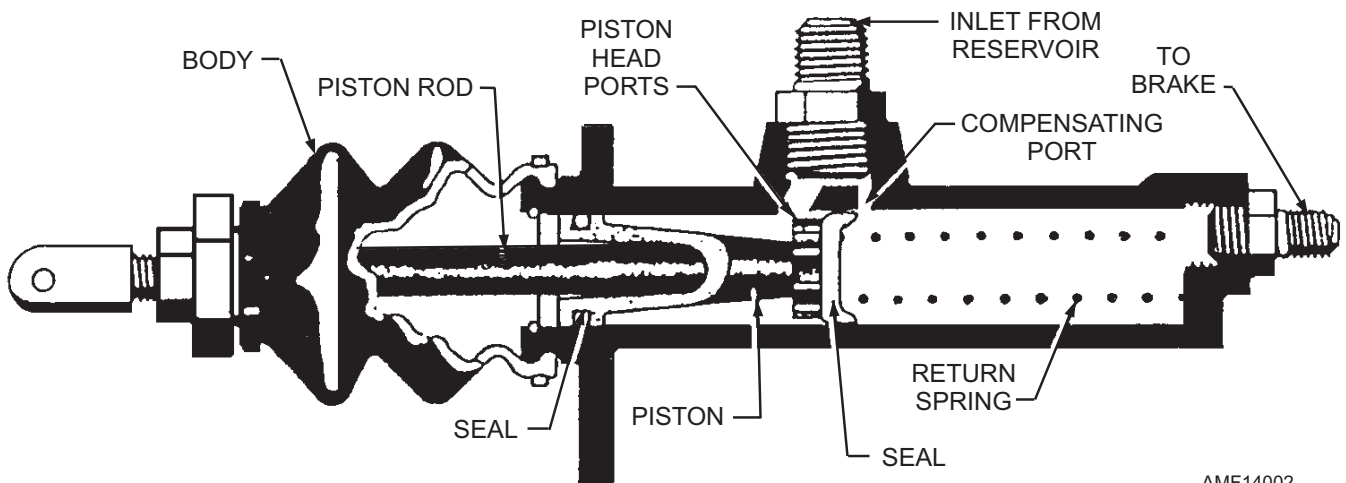

AMF14002

Figure 14-2.—Goodyear master brake cylinder.

as the piston is returned to the OFF position by the pressure of the brake piston return springs.

Any pressure or excess volume of fluid is relieved through the compensating port and passes back to the fluid reservoir. The compensating port assures against dragging or locked brakes.

If any fluid is lost back of the front piston seal due to leakage, it is automatically replaced with fluid from the reservoir by gravity. Any fluid lost in front of the piston from leaks in the line or at the brake is automatically replaced through the piston head ports, and around the lip of the front piston seal when the piston makes the return stroke to the full OFF position. The front piston seal functions as a seal only during the forward stroke. These automatic fluid replacement arrangements always keep the master cylinder, brake connecting line, and brake assembly fully supplied with fluid as long as there is fluid in the reservoir.

The rear piston seal seals the rear end of the cylinder at all times to prevent leakage of fluid. The flexible rubber boot serves only to keep out dust.

Provision is made for locking the brakes for parking by a ratchet-type lock built into the mechanical linkage between the master cylinder and the brake pedal. Any change in the volume of fluid, due to expansion while the parking brake is on, is taken care of by a spring incorporated in the linkage. The brakes are unlocked by application of sufficient pressure on the brake pedals to unload the ratchet.

Brake systems employing the Goodyear master cylinder must be bled from the top down. In no case should bleeding be attempted from the bottom up, because it is impossible to remove the air in back of the piston seal.

Gladden Master Cylinder

The Gladden master brake cylinder consists of a cylinder body, valve, piston, piston rod, return springs, and a stop assembly, as shown in figure 14-3. The piston rod extends through the valve, the piston, the stop assembly, and the return springs, and is connected by an eyebolt to the brake arm on the rudder pedal.

When the cylinder is in neutral, the valve is not seated. Fluid from an independent brake reservoir enters the cylinder's reservoir port. Fluid entering this port is allowed to flow through the piston and fill the lower chamber.

When the rudder pedal is depressed by toe pressure, the piston rod is pulled downward, causing

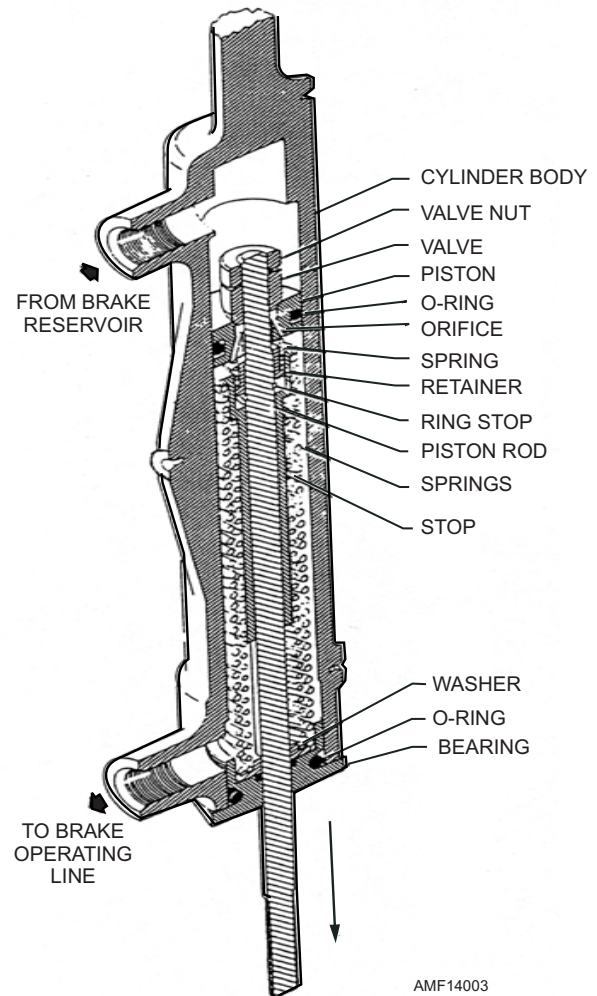

Figure 14-3.—Gladden master brake cylinder.

the valve to seat and close the piston orifice. This movement also forces fluid into the brake's pressure line to the wheel brake assembly, thus applying the brakes.

When the pedal pressure is released, the springs return the valve and the piston to their neutral position. The retracting brake assembly piston forces the return fluid back through the piston orifice to the brake reservoir.

POWER BOOST BRAKE SYSTEM

As a general rule, the power boost brake system is used on aircraft that land too fast to use the independent-type system, but are too light in weight to require the power brake control system. In this type of system, a line is tapped off from the main hydraulic system pressure line, but main hydraulic system pressure does not enter the brakes. Main system pressure is used only to assist pedal movement. This is accomplished by using power boost master cylinders.

A schematic diagram of a typical power boost brake system is shown in figure 14-4. The normal system consists of a reservoir, two power boost master cylinders, two shuttle valves, and the brake assembly in each main landing wheel. A compressed air bottle with a gauge and release valve is installed for emergency operation of the brakes.

In this system (fig. 14-4), main hydraulic system pressure is routed from the pressure manifold to the power boost master cylinders. When the brake pedals are depressed, fluid for actuating the brakes is routed from the power boost master cylinders through shuttle valves to the brakes.

When the brake pedals are released, the main system pressure port in the master cylinder is closed off, and fluid is forced out the return port, through the return line to the brake reservoir. The brake reservoir is connected to the main hydraulic system reservoir to assure an adequate supply of fluid to operate the brakes.

When the emergency air system is used, air pressure, directed through a separate set of lines, acts on the shuttle valves, blocking off the hydraulic lines and actuating the brakes.

POWER BRAKE CONTROL VALVE SYSTEM

A power brake control valve system is used on aircraft requiring a large volume of fluid to operate the

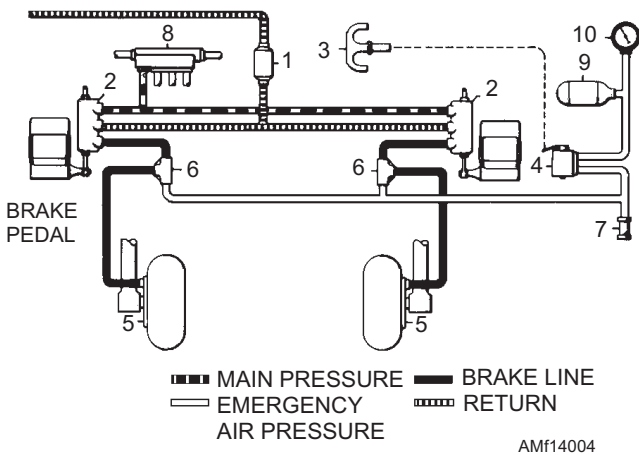

- | | |
|--------------------------------|----------------------------------|
| 1. Brake reservoir | 6. Shuttle valve |
| 2. Power boost master cylinder | 7. Air vent |
| 3. Emergency brake control | 8. Main system pressure manifold |
| 4. Air release valve | 9. Emergency air bottle |
| 5. Wheel brake | 10. Emergency air gauge |
- AMf14004

Figure 14-4.—Power boost brake system.

brakes. As a general rule, this applies to all patrol (VP) and reconnaissance (VR) aircraft, and certain attack (VA) aircraft. Because of the weight and size of the aircraft, large wheels and brakes are required. Larger brakes mean greater fluid displacement and higher pressures. For this reason, independent type master cylinder systems are not practical on heavy aircraft. A typical power brake control valve system is shown in figure 14-5.

In this system, a line is tapped off from the main hydraulic system pressure line. The first unit in this line is a check valve, which prevents loss of brake system pressure in case of main system failure.

The next unit is the accumulator, the main purpose of which is to store a reserve supply of fluid under pressure. When the brakes are applied and pressure drops in the accumulator, more fluid enters from the main system and is trapped by the check valve. The accumulator also acts as a surge chamber for excessive loads imposed upon the brake hydraulic system.

Following the accumulator are the pilot's and copilot's brake valves. The purpose of a brake valve is to regulate and control the volume and pressure of the fluid that actuates the brake.

Four check valves and two one-way restrictors, sometimes referred to as orifice check valves, are

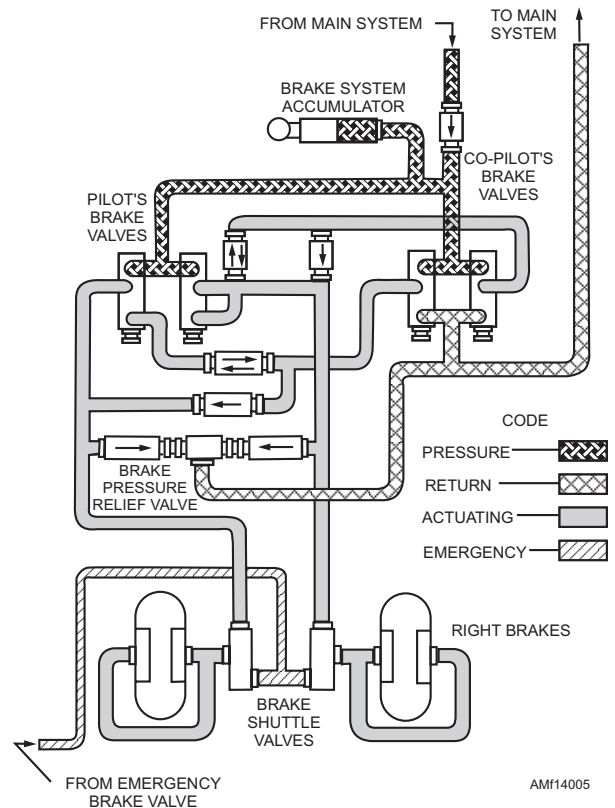

Figure 14-5.—Typical power brake control valve system.

installed in the pilot's and copilot's brake actuating lines. The check valves allow the flow of fluid in one direction only. The orifice check valves allow unrestricted flow of fluid in one direction, from the pilot's brake valve; flow in the opposite direction is restricted by an orifice in the poppet. The purpose of the orifice check valves is to help prevent chatter.

The next unit in the brake actuating lines is the pressure relief valve. In this particular system, the pressure relief valve is preset to open at 825 psi to discharge fluid into the return line. The valve closes at 760 psi minimum.

Each brake actuating line incorporates a shuttle valve for the purpose of isolating the emergency brake system from the normal brake system. When brake actuating pressure enters the shuttle valve, the shuttle is automatically moved to the opposite end of the valve. This action closes off the inoperative brake system actuating line. Fluid returning from the brakes travels back into the system to which the shuttle was last open.

Power Brake Control Valve (Pressure Ball Check Type)

A power brake control valve of the pressure ball check type is shown in figure 14-6. The valve is designed to release and regulate main system pressure to the brakes and to relieve thermal expansion when the

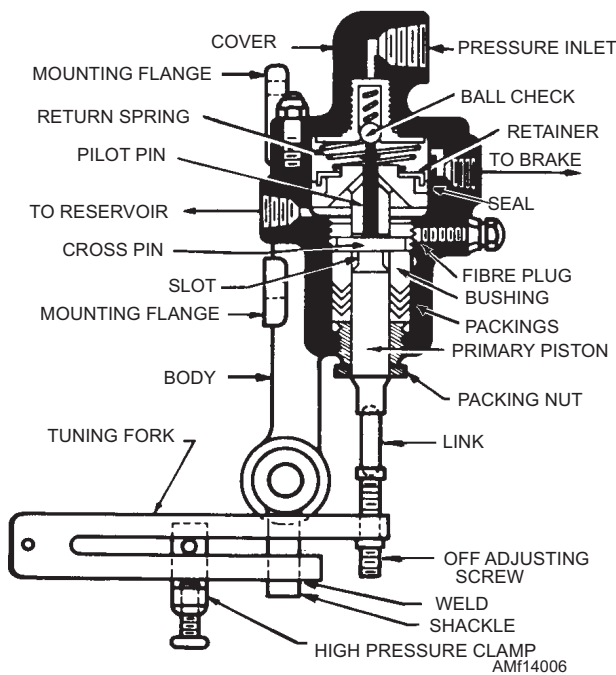

Figure 14-6.—Power brake control valve (pressure ball check type).

brakes are not being used. The main parts of the valve are the housing, piston assembly, and tuning fork.

The housing contains three chambers and three ports. They are the pressure inlet, brake, and return ports.

The piston assembly is made up of a piston head, piston shaft, pilot pin, and cross pin. The piston head separates the brake and return chambers. A cup seal prevents fluid from escaping to the return chamber when the brakes are applied. The seal is held in place by a retainer and piston return spring. The piston head has a hole drilled through its center for the flow of fluid to the return port. This hole is opened and closed by the pilot pin. The pilot pin also opens the pressure port. The flange of the pilot pin and the hole in the piston head are lapped together. The piston shaft connects the piston head with the tuning fork. The shaft is slotted, and the cross pin prevents it from turning.

The tuning fork connects the brake pedal linkage with the control valve. It swivels on the housing and limits the maximum pressure directed to the brake. The upper arm of the tuning fork is a bar spring that bends from the point of the fulcrum when hydraulic pressure overcomes toe force.

Power Brake Control Valve (Sliding Spool Type)

A sliding spool-type power brake control valve is shown in figure 14-7. Basically, this valve consists of a sleeve and a spool installed in a housing. The spool moves inside the sleeve, opening or closing either the pressure or return port of the brake line. Two springs are provided. The large spring, referred to in the illustration as the plunger spring, provides "feel" to the brake pedal. The small spring returns the spool to the OFF position.

When the plunger is depressed, the large spring moves the spool, which closes off the return port and opens the pressure port to the brake line. When the pressure enters the valve, fluid flows to the opposite end of the spool through a hole. The pressure pushes the spool back far enough toward the large spring to close the pressure port, but not open the return port. The valve is then in the static condition. This movement partially compresses the large spring, giving "feel" to the brake pedal. When the brake pedal is released, the small spring moves the spool back, opening the return port. This action allows fluid pressure in the brake line to flow out through the return port.

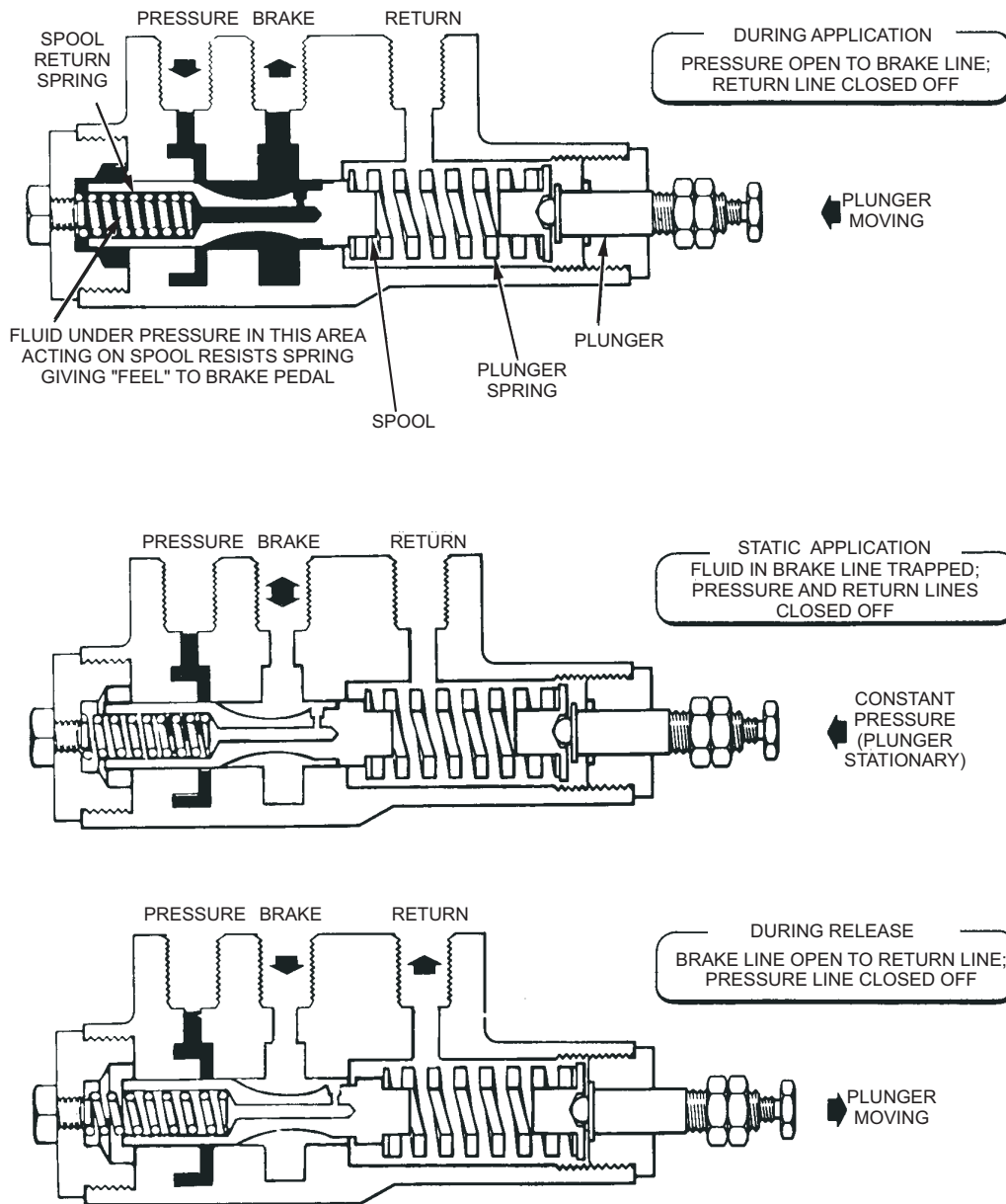

Figure 14-7.—Power brake control valve (sliding spool type).

AMF14007

Maintenance of the sliding spool brake control valve is limited to checking the action of the plunger. This is done by manually depressing the plunger until it bottoms, and then releasing it suddenly. If the plunger remains depressed (does not snap out), the valve is binding at the spool and sleeve. If binding occurs, the valve should be replaced. Disassembly of the valve is not permitted at the organizational level of maintenance, but may be performed by an intermediate or higher level activity.

Brake Debooster Cylinder

In some power brake control valve systems, booster cylinders are used in conjunction with the

power brake control valves. These units are generally used on aircraft equipped with a high-pressure hydraulic system and low-pressure brakes. The purpose of the brake booster cylinder is to reduce the pressure to the brake and increase the volume of fluid flow. Figure 14-8 shows a typical booster cylinder installation. The unit is being mounted on the landing gear shock strut in the line between the control valve and the brake. The schematic diagram in the illustration shows the internal parts of the cylinder.

When the brake is applied, fluid under pressure enters the inlet port to act on the small end of the piston. The ball check prevents the fluid from passing through the shaft. Force is transmitted through the small end of

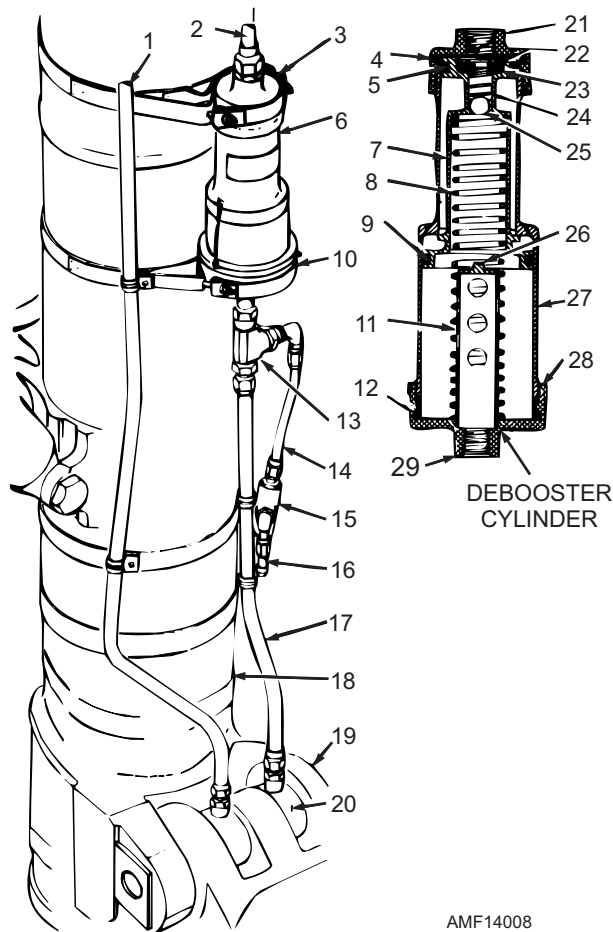

AMF14008

- | | | |
|-----------------------------------|---|---------------------|
| 1. Emergency system pressure line | 11. Riser tube | 21. Inlet port |
| 2. Main brake pressure line | 12. Packing | 22. Snapping |
| 3. Upper support clamp | 13. Tee fitting | 23. Spring retainer |
| 4. Packing | 14. Brake line (to pressure relief valve) | 24. Valve spring |
| 5. Packing | 15. Brake pressure-relief valve | 25. Ball |
| 6. Debooster cylinder assembly | 16. Overflow line | 26. Ball pedestal |
| 7. Piston | 17. Brake line (debooster to shuttle valve) | 27. Barrel |
| 8. Piston return spring | 18. Shock strut | 28. Lower end cap |
| 9. Packing | 19. Torque link | 29. Outlet port |
| 10. Lower support clamp | 20. Brake shuttle valve | |

Figure 14-8.—Brake debooster cylinder.

the piston to the large end of the piston. As the piston moves downward in the housing, a new flow of fluid is created from the large end of the housing through the outlet port to the brake. Because the force from the small piston head is distributed over the greater area of the large piston head, pressure at the outlet port is reduced. At the same time, a greater volume of fluid is displaced by the large piston head than that used to move the small piston head.

Normally, the brake will be fully applied before the piston has reached the lower end of its travel. However, if the piston fails to meet sufficient resistance to stop it

(due to a loss of fluid from the brake unit or connecting lines), the piston will continue to move downward until the riser unseats the ball check valve in the hollow shaft. With the ball check valve unseated, fluid from the power control valve will pass through the piston shaft to replace the lost fluid. Since the fluid passing through the piston shaft acts on the large piston head, the piston will move up, allowing the ball check valve to seat when pressure in the brake assembly becomes normal.

When the brake pedal is released, pressure is removed from the inlet port, and the piston return

spring moves the piston rapidly back to the top of the de booster. This rapid movement causes a suction in the line to the brake assembly, resulting in faster release of the brake.

EMERGENCY BRAKE SYSTEM

On all aircraft except those equipped with independent-type brake systems, an emergency brake system is provided. On some aircraft a pneumatically operated emergency system is provided. Others have a reserve hydraulic system; an emergency hydraulic reservoir retains a sufficient supply of hydraulic fluid for manual operation of the brakes in case no hydraulic power is available.

The power boost brake system, described earlier, is equipped with a pneumatically operated emergency system. The emergency system consists of a T-handle, compressed air bottle, air release valve, and pressure gauge.

The system is operated by pulling the T-handle. This releases the compressed air stored in the air bottle. Air pressure unseats the shuttle valves at the air inlet ports and seats the hydraulic pressure ports. Air pressure is then applied directly to the brakes.

Once air pressure has been applied, the brake can be released only by depressing a button on the air release valve. Brake systems must be bled after using the emergency pneumatic systems, and the air storage bottle must be serviced with the specified amount of dry compressed air or nitrogen. A pressure gauge indicates the amount of air in the bottle, in pounds per square inch (psi).

- Q14-1. What type of brake assembly has its own reservoir and is entirely independent of the aircraft's main hydraulic system?*
- Q14-2. On a Goodyear master brake cylinder, how is the hydraulic fluid fed from the external reservoir to the master cylinder?*
- Q14-3. What method is used to bleed a brake system employing a Goodyear master cylinder?*
- Q14-4. The main system pressure in a power boost brake system is used for what function?*
- Q14-5. Because of the weight and size, what type of brake system is used on aircraft requiring a large volume of fluid to operate the brakes?*
- Q14-6. What connects the brake pedal linkage to the control valve of the power brake control valve (pressure ball type)?*

Q14-7. What is the purpose of the brake de booster cylinder?

Q14-8. With the exception of those aircraft equipped with independent-type brake systems, what additional brake systems are provided?

BRAKE ASSEMBLIES

LEARNING OBJECTIVE: Identify the various types of brake assemblies.

Brake assemblies commonly used on naval aircraft are the single disc, dual disc, multiple or trimetallic disc, and segmented rotor. The single and dual disc types are more commonly used on small aircraft; the multiple or trimetallic disc types are normally used on medium-sized aircraft; and the segmented rotor types are commonly found on heavier types of aircraft.

SINGLE DISC BRAKES

The single disc brake is very effective for use on smaller types of aircraft. Braking is accomplished by applying friction to both sides of a rotating disc—the disc being keyed to the landing gear wheel. There are several variations of the single disc brake; however, all operate on the same principle and differ mainly in the number of cylinders and the types of brake housing. Brake housings may be either the one piece or divided type. Figure 14-9 shows a single disc brake installed on an aircraft, with the wheel removed. The brake housing is attached to the landing gear axle flange with mounting bolts.

Figure 14-10 shows an exploded view of a typical single disc brake assembly. This brake assembly has a three-cylinder, one-piece housing. Each cylinder in

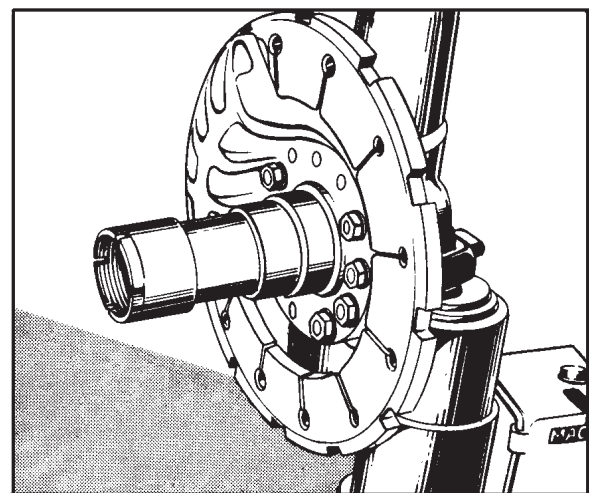

AMF14009

Figure 14-9.—Typical single disc brake installation.

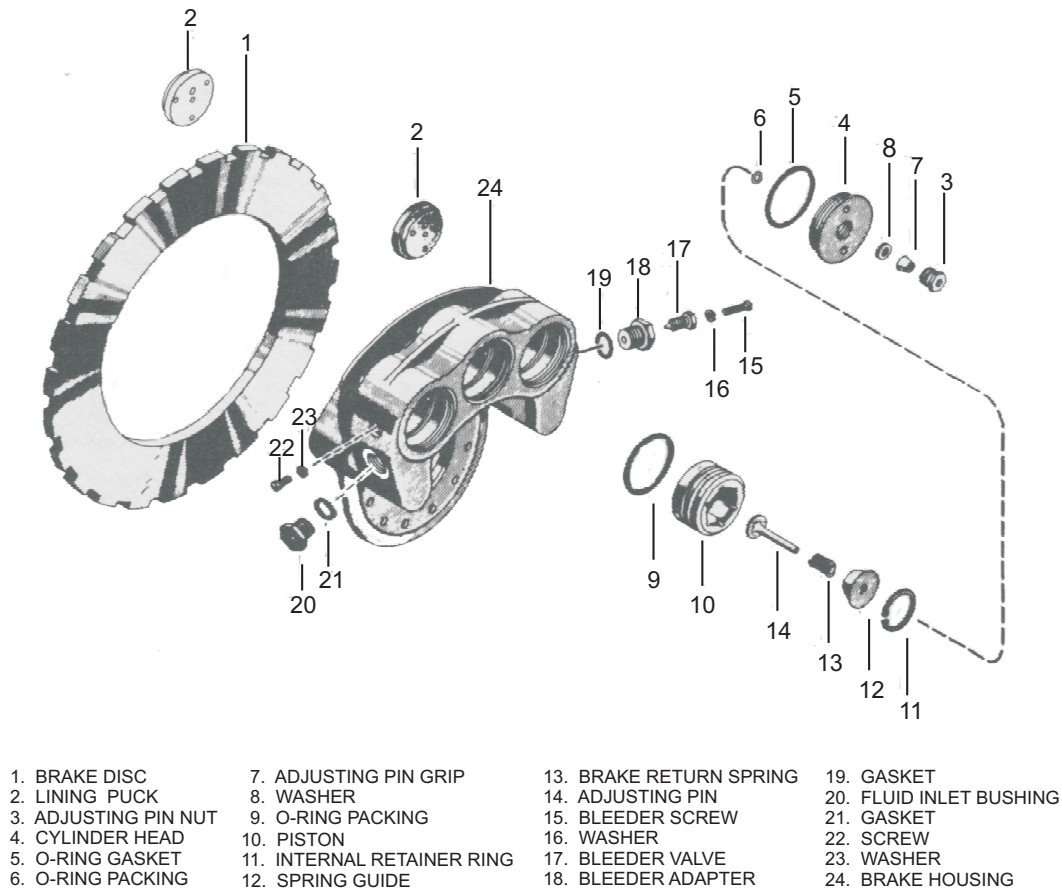

AMf14010

Figure 14-10.—Exploded view of single disc brake assembly.

the housing contains a piston, a return spring, and an automatic adjusting pin.

There are six brake linings (pucks), three on the inboard side of the rotating disc and three on the outboard side of the rotating disc. These brake linings are often referred to as “pucks.” The outboard lining pucks are attached to the three pistons, and they move in and out of the three cylinders when the brakes are operated. The inboard lining pucks are mounted in recesses in the brake housing and are stationary.

Hydraulic pressure from the brake control unit enters the brake cylinders and forces the pistons and their pucks against the rotating disc. At the same time, the piston pushes against the adjusting pin (through the spring guide) and moves the pin inboard against the friction of the adjusting pin grip.

The rotating disc is keyed to the landing gear wheel so that it is free to move laterally within the brake cavity of the wheel. Thus, the rotating disc is forced into contact with the inboard pucks mounted in the housing. This lateral movement of the rotating disc ensures equal braking action on both sides of the disc.

When pressure is relieved, the force of the return spring is sufficient to move the piston away from the brake disc, but it is not enough to move the adjusting pin, which is held by the friction of the pin grip. The piston moves away from the disc until it stops against the head of the adjusting pin, which provides a preset clearance between the pucks and the disc. The self-adjusting feature of the brake will maintain the desired puck-to-disc clearance, regardless of lining wear. Thus, regardless of the amount of wear, the same travel of the piston will be required to apply the brake.

Maintenance of the single disc brake may include bleeding, performing operational checks, checking lining wear, checking disc wear, and replacing worn linings and discs.

A bleeder valve is provided on the brake housing (fig. 14-10) for bleeding the single disc brake. Bleeding should be performed according to the instructions contained in the aircraft MIM.

Operational checks are made during taxiing. Braking action for each main landing gear wheel should be equal, with equal application of pedal pressure and without any evidence of soft or spongy

action. When pedal pressure is released, the brakes should release without any evidence of drag. All disc-type brakes must be checked periodically for lining wear. Excessively worn linings must be replaced.

Lining wear may be checked by two methods. The method used depends upon the model of the brake assembly. Both methods are described later in this chapter. Before checking the brakes on any aircraft, always refer to the applicable MIM and use the method recommended by the aircraft manufacturer.

DUAL DISC BRAKES

Dual disc brakes are used on aircraft where more braking friction is desired with lower pressures.

The dual disc brake is very similar to the single disc type, except that two rotating discs, instead of one, are used. One model of this brake is shown in figure 14-11.

The unit consists of a housing assembly, a center carrier assembly, and two rotating discs. The housing assembly contains four cylinders, each of which contains a piston, a return spring, and a self-adjusting pin. Brake linings (pucks) are attached to each piston,

to both sides of the center carrier, and to the housing assembly, which makes a total of 16 pucks.

When hydraulic pressure is applied to the pistons, the pucks are forced against the first disc, which contacts the pucks in the center carrier. This force moves the center carrier and its pucks against the second disc, forcing it in contact with the pucks in the housing. In this manner, each disc receives equal braking action on both sides as the pressure is increased. When brake pressure is released, the return springs force the pistons back to the preset clearance between the pucks and the disc. The self-adjusting feature is identical to that described for the single disc brakes. Maintenance of the dual disc brake is the same as that previously given for the single disc type.

MULTIPLE/TRIMETALLIC DISC BRAKES

Multiple disc brakes are heavy-duty brakes designed for use with power brake control valves or power boost master cylinders. The brake assembly consists of a bearing carrier; bearings and retaining nut; the annular actuating piston; and the heat stack, which is composed of a pressure plate, rotating discs (rotors), stationary discs (stators) and backup plate, an automatic adjuster, retracting springs, and various other components.

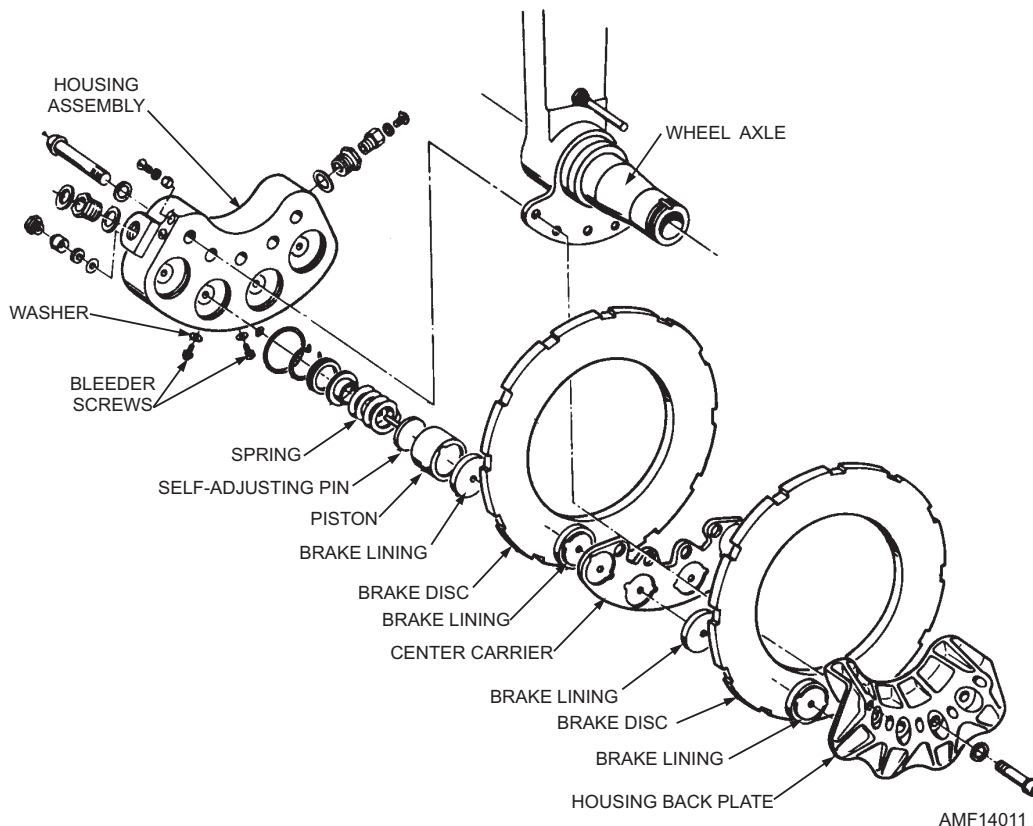

Figure 14-11.—Dual disc brake.

Regulated hydraulic pressure is applied through the automatic adjuster to a chamber in the bearing carrier. The bearing carrier is bolted to the shock strut axle flange and serves as a housing for the annular actuating piston. Hydraulic pressure forces the annular piston to move outward, compressing the rotating discs, which are keyed to the landing wheel, and the stationary discs, which are keyed to the bearing carrier. The resulting friction causes a braking action on the wheel and tire assembly.

When the hydraulic pressure is relieved, the retracting springs force the actuating piston to retract into the housing chamber in the bearing carrier. The hydraulic fluid in the chamber is forced out by the return of the annular actuating piston, and is bled through the automatic adjuster to the return line. The automatic adjuster traps a predetermined amount of fluid in the brake—an amount just sufficient to give correct clearances between the rotating discs and stationary discs. See figure 14-12

The trimetallic disc type brakes are used on most naval aircraft. They operate on the same basic principle as the multiple disc brakes.

SEGMENTED ROTOR BRAKES

Segmented rotor brakes are heavy-duty brakes, especially adapted for use with high-pressure hydraulic systems. These brakes may be used with either power brake control valves or power boost master cylinders. Braking is accomplished by means of several sets of stationary, high-friction type of brake linings making contact with rotating (rotor) segments. A cutaway view of the brake is shown in figure 14-13. As you can see, the segmented rotor brake is very similar to the multiple disc type, described in the previous section.

The brake assembly consists of a carrier, two pistons and piston cup seals, a pressure plate, an auxiliary stator plate, rotor segments, stator plates, a compensating shim, automatic adjusters, and a backing plate.

- Q14-9. What types of disc brakes are usually installed on medium-sized aircraft?*
- Q14-10. On disc brake assemblies, brake linings are often referred to by what name?*
- Q14-11. When are operational checks on disc brakes usually performed?*

- Q14-12. What types of brakes are used on aircraft where more braking friction is desired with lower pressures?*
- Q14-13. What is the total number of pucks installed on dual disc brakes?*
- Q14-14. What traps a predetermined amount of fluid in the brake to give correct clearance between the rotating discs and the stationary discs in multiple/trimetallic brake systems?*
- Q14-15. What types of brakes are designed for high-pressure hydraulic systems and are considered heavy-duty brakes?*

BRAKE SYSTEM MAINTENANCE

LEARNING OBJECTIVE: Identify the two primary brake systems. Identify the checks required to make sure these systems operate properly.

Brake systems are designed to retard or to stop aircraft motion on the ground. They also aid in controlling the direction of the aircraft while it is taxiing. Provisions exist for applying either one or both brakes and for varying the braking action by the amount of movement or force exerted on the brake pedal.

Several types of naval aircraft have an antiskid system integrated with the wheel brake system to allow maximum braking. This results in a short landing roll and skid-free control as the aircraft comes to a stop.

A large portion of the maintenance effort expended by an AM in an operating activity is directed toward troubleshooting and repairing of brakes and brake systems. A brake system is generally one of two major types—independent or power. Independent systems operate independently of a pressure source other than the master cylinder. Power brake systems use utility or main hydraulic system pressure from the aircraft. The power brake systems allow for higher brake line pressures than can be obtained with the independent system.

INDEPENDENT-TYPE BRAKE SYSTEM

The depth of independent brake system maintenance allowable at the intermediate and organizational levels of maintenance varies with the complexity of the components. System maintenance at the organizational level generally consists of servicing, troubleshooting, parts replacement, and “on aircraft” repairs.

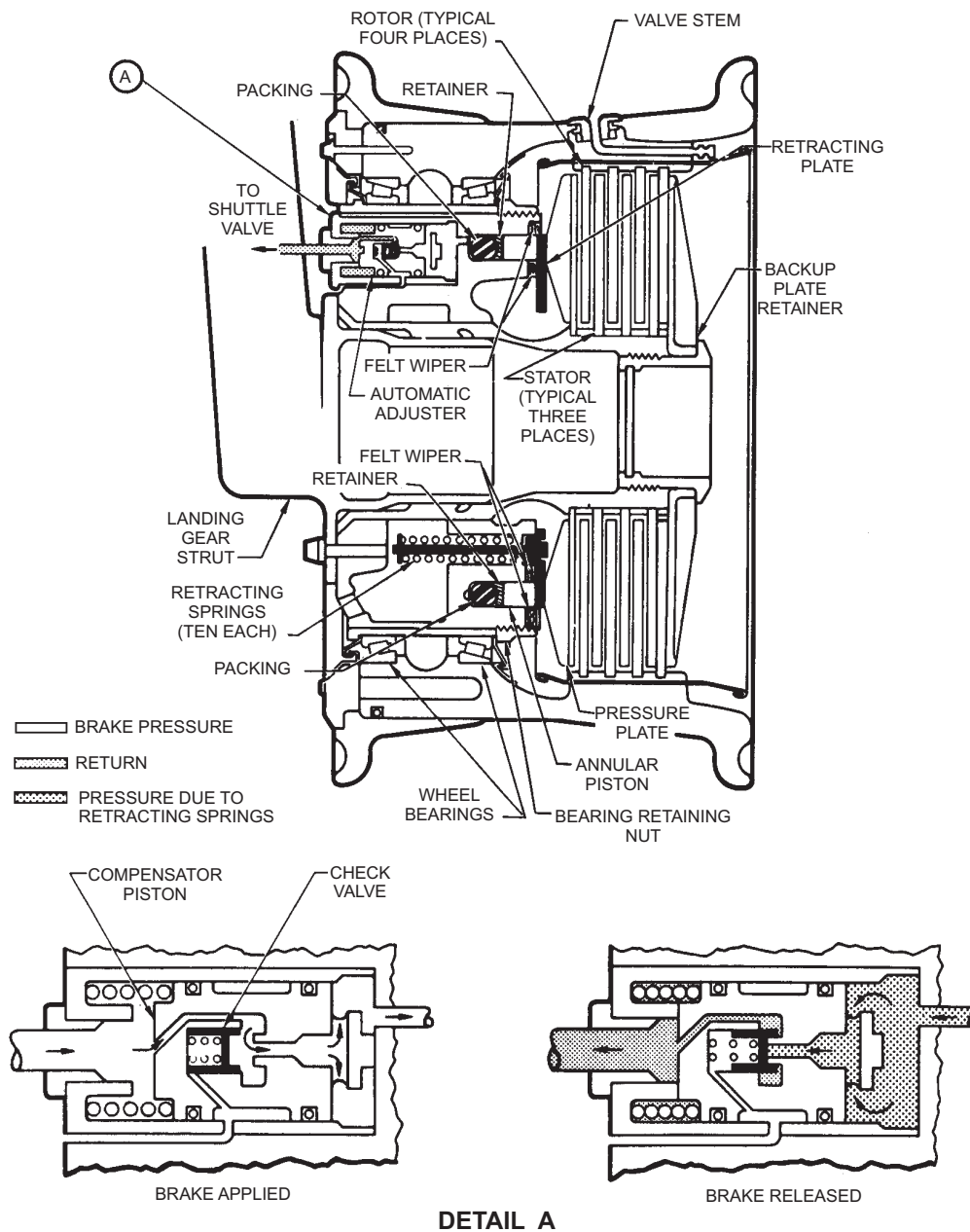

Figure 14-12.—Cross-sectional view of multiple disc brake.

AMF14012

Reservoir maintenance is limited to servicing, removal, repair, parts replacement, testing, and installation. Servicing of the reservoir requires that filtered hydraulic fluid be gravity fed into the reservoir through the filler opening until the sight gauge indicates it is full. The reservoir should not be overfilled. The area around the filler neck should be cleaned before you remove the filler plug to prevent any form of contamination from being introduced into the reservoir and the brake system.

As with other systems, a troubleshooting chart is furnished in the MIM for use in troubleshooting/

analyzing main landing gear wheel and independent brake system malfunctions.

POWER-TYPE BRAKE SYSTEM

Organizational maintenance of the power/manual brake system consists of checking system operation, system adjustment, isolating malfunctions, and replacement and adjustment of system components. See figure 14-14. The checkout procedures in most MIMs are provided for use during established inspections or for use in performing trouble analysis.

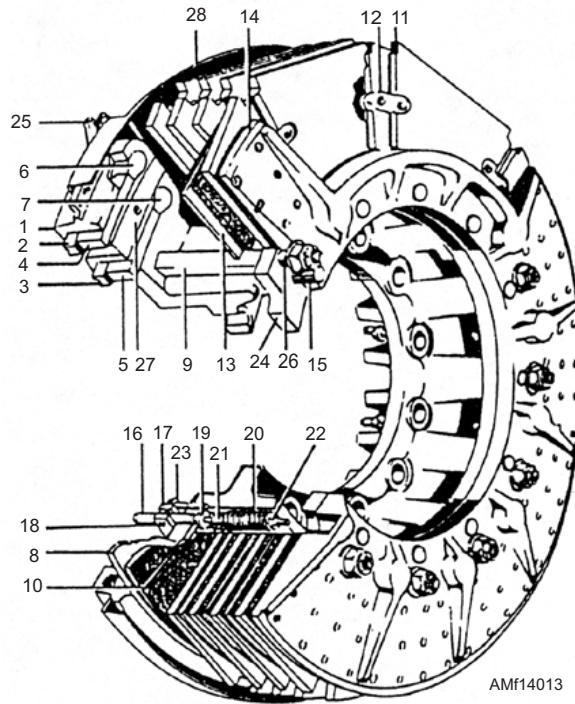

- | | | |
|--|----------------------------|-----------------------------|
| 1. Carrier assembly | 11. Rotor segment | 21. Adjuster sleeve |
| 2. Piston cup (outer) | 12. Rotor link | 22. Adjuster nut |
| 3. Piston cup (inner) | 13. Stator plate | 23. Clamp holddown assembly |
| 4. Piston (outer) | 14. Backing plate | 24. Shim |
| 5. Piston (inner) | 15. Torque pin | 25. Bleeder screw |
| 6. Piston end (outer) | 16. Adjuster pin | 26. Drive sleeve bolt |
| 7. Piston end (inner) | 17. Adjuster clamp | 27. Dust cover (inner) |
| 8. Pressure plate | 18. Adjuster screw | 28. Dust cover (outer) |
| 9. Stator drive sleeve | 19. Adjuster washer | |
| 10. Auxiliary stator and lining assembly | 20. Adjuster return spring | |

Figure 14-13.—Segmented rotor brake—cutaway view.

GENERAL BRAKE SYSTEM MAINTENANCE

Proper functioning of the brake system is of the utmost importance. Inspections must be performed at frequent intervals, and maintenance work must be performed promptly and carefully.

Operational Checks

Prepare the aircraft for an operational checkout by installing the landing gear down locks, jacking the aircraft to provide proper ground clearance for the landing gear, and applying external electrical power. Placing the antiskid switch in the OFF position should illuminate the antiskid warning light. When the landing gear handle is moved to the UP position, the antiskid light should go out. At this point, external

hydraulic power is slowly applied to the utility system. The wheels should not rotate. By placing the landing gear handle to the DOWN position, it should illuminate the antiskid light and free the wheels to rotate. The brake pedals should be fully depressed to apply the brakes a minimum of three times.

With external hydraulic and electrical power removed from the aircraft, operationally check the emergency system by pulling the emergency brake handle. The wheels should not rotate when the handle is pulled. Releasing the handle should immediately release the brakes. If any portion of the operational or functional test does not meet the results specified in the MIMs, refer to the trouble analysis sheets for the brake system.

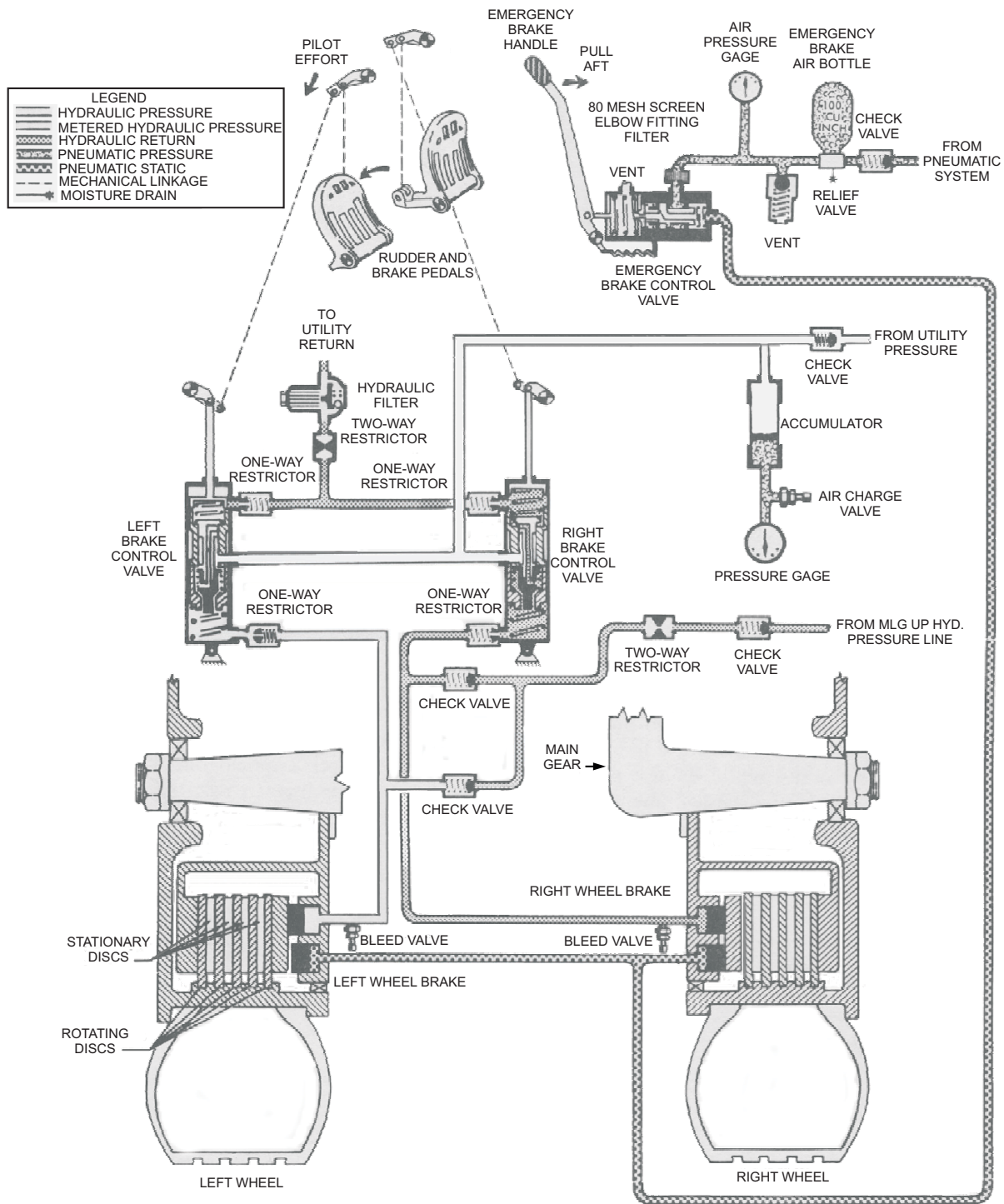

AMF14014

Figure 14-14.—Power/manual brake systems—schematic.

Functional Tests

Prepare the aircraft for a complete functional checkout by installing the landing gear down locks, jacking the aircraft to provide ground clearance for the landing gear, installing pressure gauges in the wheel brake assembly's bleed ports, and applying external electrical and hydraulic power.

When the antiskid switch is in the OFF position, the antiskid warning light will illuminate. Move the landing gear handle to the UP position, which will cause the antiskid warning light to go out. The gauges on the brake assemblies should indicate 650 to 1,000 psi. Place the landing gear handle to the DOWN position to illuminate the antiskid warning light. The brake gauges should indicate a maximum of 75 psi, and the wheels should be free to rotate.

Remove electrical power from the aircraft. Depress the brake pedals several times to check braking action. Place a bubble protractor on the brake pedals and adjust to zero when the brakes are in the OFF position. When the brakes are fully depressed, the protractor should indicate 30 degrees \pm 1 degree, and the hydraulic gauges on the brake assemblies should indicate the same pressure as the external hydraulic power source.

The external hydraulic power is shut down and system pressure is relieved by operating the rudder pedals. Check brake accumulator action by fully depressing the brake pedals several times and checking the brake assembly action. Check the emergency brake system in the same manner as described for the operational checkout.

The next steps of the functional checkout require that the wheel and tire assemblies be removed and hydraulic power reapplied. Depress the brake pedals for approximately 1 minute, and check each power plate for hydraulic leakage.

Check lining wear by depressing the brake pedals. Measure the gap between the face of the primary disc

assembly (1) and the screw thread insert (11). See figure 14-15. Lining wear should not exceed 0.816 inch. Check running clearance by first applying the brake pedals until 1,200 psi is indicated on the gauges installed in the brake bleed ports. Measure the distance between the primary disc and the face of the screw thread insert. Release the brakes and measure the distance again. Subtract this dimension from that obtained with the brakes applied to obtain the running clearance. Clearance should be 0.070 to 0.119 inch.

Brake Wear Check

Lining wear may be checked by two methods. Before checking the brakes on any aircraft, always refer to the applicable MIM and use the method recommended by the aircraft manufacturer.

WEAR CHECK METHOD (NO. 1).—Have a person in the cockpit apply the brake, and with the brake applied, measure the distance between the face of the brake disc and the brake housing, as shown in figure 14-16. If this distance has progressed to the maximum specified measurement given in the MIM,

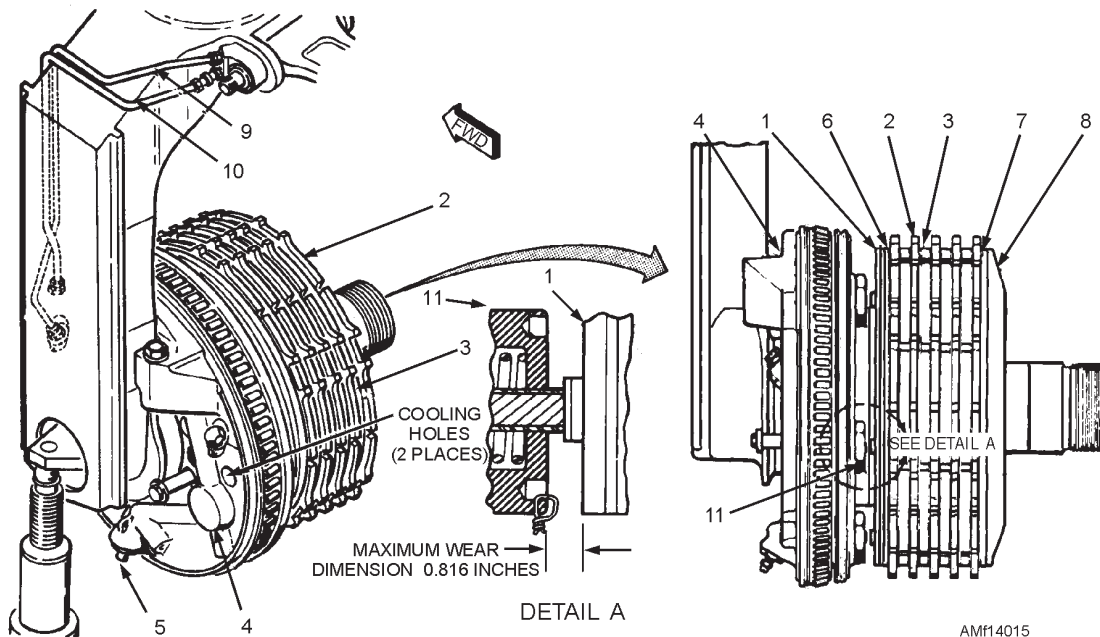

- | | |
|-----------------------------|----------------------------------|
| 1. Primary disc assembly | 7. Secondary disc insulation |
| 2. Rotors | 8. Secondary disc assembly |
| 3. Stators | 9. Pneumatic pressure line |
| 4. Power plate assembly | 10. Hydraulic pressure line |
| 5. Bleed valve | 11. Screw thread insert (5 each) |
| 6. Primary disc lining face | |

Figure 14-15.—Wheel brake.

the brake should be removed and disassembled, and the lining pucks inspected for wear.

NOTE: Linings can be measured only by removing and disassembling the brake. If any puck has worn to a thickness of less than one-sixteenth inch, the entire set must be replaced. NEVER MIX NEW AND USED LININGS.

WEAR CHECK METHOD (NO. 2).—In using this method, have a person in the cockpit apply the brake. With the brake applied, check the position of the automatic adjusting pins (fig. 14-17). If any adjusting pin recedes inside the adjusting pin nut (one-sixteenth to three-eighth inch, the exact amount depending on the brake model), the brake must be removed and disassembled, and the lining thickness checked. If any lining is worn to a thickness of one-sixteenth inch or less, the entire set of linings must be replaced. Figure 14-17 illustrates the normal position of the automatic adjusting pin (protruding out of the adjusting pin nut).

Emergency System Contamination Check

Check the emergency system for contamination. Remove the plug from the unused pneumatic pressure port on the brake assembly. Position a clean, white cloth adjacent to the opening, and slowly pull the emergency brake control handle. Allow airflow through the system for approximately 5 seconds. There should be no evidence of combustible

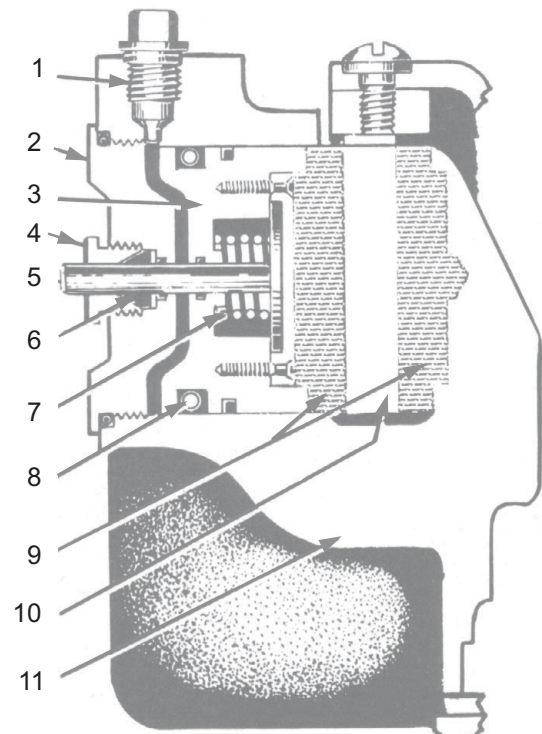

AMF14017

- | | |
|----------------------------|-------------------------|
| 1. Brake fluid port | 7. Piston return spring |
| 2. Cylinder head | 8. O-ring packing |
| 3. Piston | 9. Brake lining |
| 4. Adjusting pin nut | 10. Brake disc |
| 5. Automatic adjusting pin | 11. Brake lining |
| 6. Adjusting pin grip | |

Figure 14-17.—Normal position of automatic adjusting pin.

contaminants on the cloth. If the system is contaminated, the emergency brake pneumatic lines from the brake control valve to the brake assembly must be flushed with a suitable solvent. Purge for a minimum of 15 minutes with heated nitrogen.

Bleeding Procedures

There are two general methods of bleeding brake systems—bleeding from top downward (top-down method) and bleeding from the bottom upward (bottom-up method). The method used generally depends on the type and design of the brake system to be bled. In some instances it may depend on the bleeding equipment available.

TOP-DOWN METHOD.—In using the top-down method, the air is expelled from the system through one of the bleeder valves provided on the brake assembly. See figure 14-18. A bleeder hose is attached to the bleeder valve, and the free end of the hose is placed in a container that has enough hydraulic fluid to

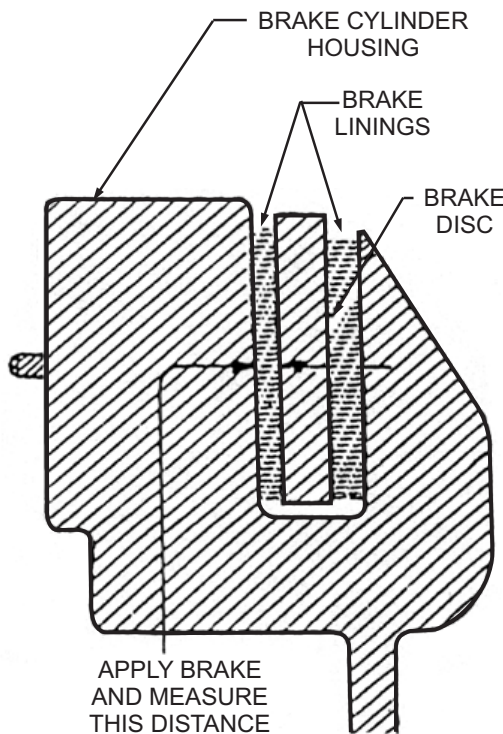

AMF14016

Figure 14-16.—Checking lining wear (Method No. 1).

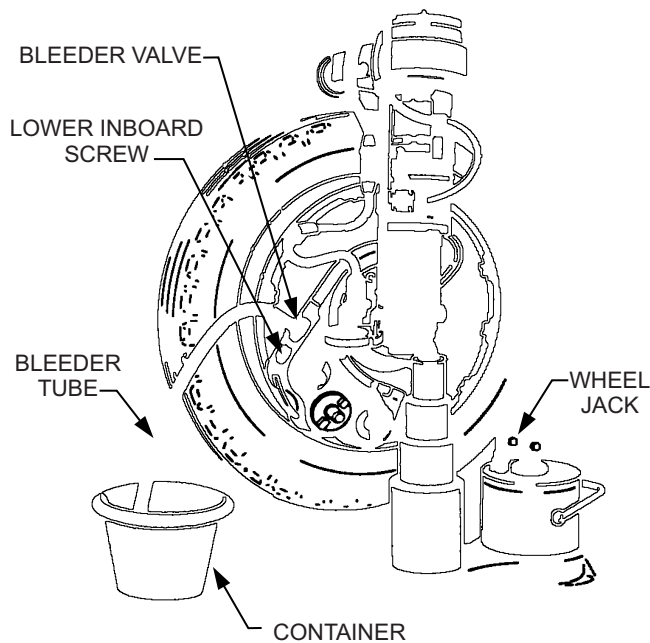

Figure 14-18.—Bleeding brake system (top-down method).

cover the end of the hose. The air-laden fluid is then forced from the system by applying the brakes. If the brake system is a part of the main hydraulic system, a portable hydraulic test stand may be used to supply the pressure. If the system is an independent master cylinder system, the master cylinder will supply the necessary pressure. In either case, each time the brake pedal is released, the bleeder valve must be closed or the bleeder hose pinched off; otherwise, more air will be drawn back into the system. Bleeding should continue until no more air bubbles come through the bleeder hose into the bleeder container.

BOTTOM-UP METHOD.—In the bottom-up method, the air is expelled through the brake system reservoir or other specially provided location. Some aircraft have a bleeder valve located in the upper brake line. In this method of bleeding, pressure is supplied by a bleeder bomb. A bleeder bomb (fig. 14-19) is a portable tank in which hydraulic fluid is placed, and then put under pressure with compressed air. The bleeder bomb is equipped with an air valve, air gauge, and a connector hose. The connector hose, which attaches to the bleeder valve on the brake assembly, is provided with a shutoff valve. Normally, the hose is connected to the lowest bleed fitting on the brake assembly. With the brake bleed fitting opened, opening the bleeder bomb shutoff valve allows pressurized fluid to flow from the bleeder bomb through the brake system until all the trapped air is

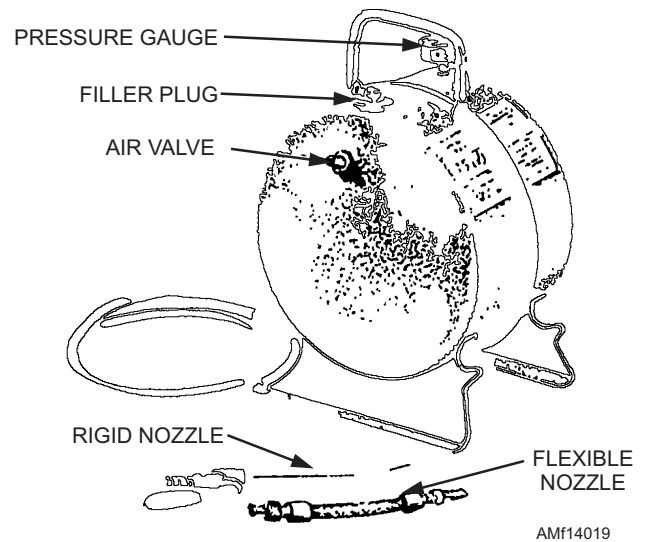

Figure 14-19.—Bleeder bomb.

expelled. The brake bleeder valve is then secured, and the bleeder bomb hose is disconnected.

This method of bleeding should be performed strictly in accordance with specific instructions for the aircraft concerned. Although the bleeding of individual systems presents individual problems, the following precautions should be observed in all bleeding operations:

1. Ensure that the bleeding equipment is absolutely clean and filled with the proper type of hydraulic fluid.
2. Maintain an adequate supply of fluid during the entire operation. A low fluid supply will allow more air to be drawn into the system.
3. Continue bleeding until no more air bubbles are expelled from the system and a firm brake pedal is obtained.
4. Check the reservoir fluid level after the bleeding operation is completed. With brake pressure on, check the entire system for leaks.

Overheated Wheel Brakes

In the event an aircraft has been subjected to excessive braking, the wheels may be heated to the point where there is danger of a blowout or fire.

NOTE: Excessive brake heating weakens tire and wheel structures, increases tire pressure, and creates the possibility of fire in the magnesium wheels. When the brakes on an aircraft have been used excessively, the fire department should be notified immediately, and all unnecessary personnel should be advised to leave the immediate area.

If blowout screens, such as the one shown in figure 14-20, are available, they should be placed around both main wheels. These screens help to eliminate the possibility of damage or injury in the event of a blowout. Sudden cooling may cause an overheated wheel to fracture or fly apart, which could hurl bolts or fragments through the air with sufficient speed to injure personnel. Required personnel should approach overheated wheels with extreme caution in the fore or aft directions—never in line with the axle.

NOTE: The area on both sides of the tire and wheel, in line with the axle, is where the fragments would be hurled if the tire were to explode; therefore, it is called the danger area. See figure 14-20.

Heat transfer to the wheel will continue for some period of time until the brake is cooled. The danger of explosive failure may exist after the aircraft is secured if action is not taken to cool the overheated brake.

The recommended procedure for cooling overheated wheel, brake, and tire assemblies is to park the aircraft in an isolated location. Allow the assembly to cool in ambient air for a period of 45 to 60 minutes. The use of cooling agents to accelerate cooling is not recommended unless operational necessity dictates their use. The application of the agents exposes personnel to danger by requiring their presence near the overheated assembly. However, if it is necessary to accelerate cooling, use an intermittent stream of water or fog.

When using water, direct a stream to the brake. The water should be applied in 10- to 15-second periodic bursts, not in a continuous discharge. Each application should be separated by a waiting period of at least 30 to 60 seconds. A minimum of three to five applications is usually necessary.

When fog is used, the fog is deflected to the brake side of the wheel for a period of 5 to 10 seconds. Each application should be separated by a waiting period of at least 20 seconds. This method is applied as long as it is necessary to control the temperature of the affected assembly.

Once the brake has been properly cooled, permit the wheel to cool in ambient air. A crosswind or forced air from a blower or fan will assist in cooling the wheel. The aircraft should not be moved for at least 15 minutes after cooling operations.

- Q14-16. What type of brake system uses utility or main hydraulic system pressure from the aircraft, which allows for higher brake line pressure?*
- Q14-17. What is used to check the reservoir fluid level on an independent brake system?*
- Q14-18. What power source should be removed from the aircraft prior to operationally checking the emergency braking system?*
- Q14-19. During the operational check of the braking system, the antiskid light will illuminate when the antiskid switch is placed in what position?*
- Q14-20. When checking brake linings, what is the wear limitation that requires the entire set of linings to be replaced?*
- Q14-21. How many minutes must the emergency brake system be purged with heated nitrogen?*
- Q14-22. When you bleed aircraft brake systems, what factor generally determines the method to be used?*

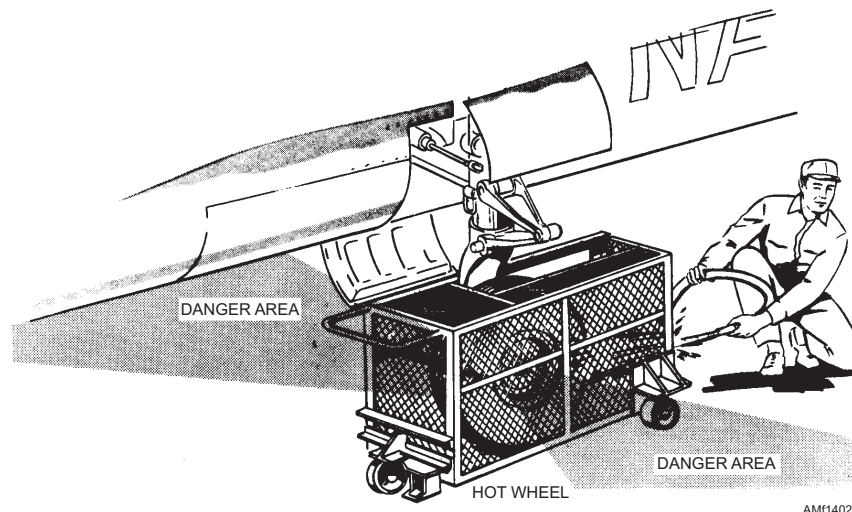

Figure 14-20.—Use of blowout screen on overheated brakes.

- Q14-23. *In the bottom-up method of bleeding a brake system, what is the portable tank called that supplies the pressure?*
- Q14-24. *What is the minimum period of time that an overheated wheel brake assembly must be allowed to cool in ambient air?*

BRAKE SYSTEM COMPONENT MAINTENANCE

LEARNING OBJECTIVES: Recognize the various components of a representative brake system, such as valves, reservoirs, and swivels. Identify the operation of a brake master cylinder.

Components of brake systems are not peculiar to any one system. A given component will vary in shape, size, capacity, and manner of operation (depending upon the manufacturer), but the function remains the same. In this section, we will discuss some of the more common brake system component maintenance practices.

INDEPENDENT SYSTEM RESERVOIR

Repair of this brake reservoir is limited to disassembly, cleaning, and replacement of high usage parts from a cure-date repair kit. These high usage parts consist of a new sight glass with its O-ring seal, washer, and retainer; a new filter, packing, and plug; and a new nameplate for the reservoir housing.

Clean the reservoir inside and out with P-D-680 cleaning solvent. Use a fiber brush on threads. Dry the interior with clean, dry compressed air from a regulated low-pressure source.

After the reservoir is cleaned and the cure-date repair kit parts have been installed, conduct a leakage test. This is accomplished by connecting a source of 25-psi air to the filler port and applying pressure. The reservoir should then be submerged in a tank of water for a minimum of 2 minutes. No leakage should be seen.

POWER BRAKE VALVE

Maintenance of these valves at organizational-level activities is limited to removal and replacement. After installation, rig the valves. Make an operational check of the brake system in accordance with the MIMs. Repair of the brake control valve consists of

disassembly, cleaning, inspection, reassembly, and testing.

Disassembly

Perform the disassembly in a clean working area. As you remove parts, place them in a clean container for protection against dirt and damage. If the valve is to be disassembled for a considerable length of time, the parts should be protected from moisture. Note the method of lockwiring for reference during the reassembly process. Remove the end cap and the plunger assembly as a unit. Disassemble the end cap and plunger assembly for inspection, cleaning, and replacement of sealing devices. Remove the opposite end cap and remove the slide and sleeve assembly as a unit for disassembly.

Cleaning

Use P-D-680 cleaning solvent to clean parts. Except for the slide and sleeve, remove stubborn accumulations of dirt with a stiff bristle nonmetallic brush moistened in cleaning solvent. Dry all parts with low-pressure, dry, filtered air.

NOTE: The slide and the sleeve assembly are precision lapped parts; they must be kept together as a matched set. You should take extra care to prevent damage during maintenance.

Inspection

Using a strong light and preferably some magnification, inspect all parts for scoring, nicks, cracks, burrs, excessive wear, corrosion, or damage. Carefully examine all packing grooves and lands for burrs and damage. The chrome plating of the plunger should be inspected for blisters, pinholes, flaking, or damage, and plating should be continuous. The sliding surfaces of the slide and sleeve should be free from scratches, burrs, or nicks. Inspect the seating edges of the slide for sharpness and freedom from nicks and burrs. Any damage to the slide and sleeve will necessitate replacement of both parts of the matched assembly. The holes in the valve-actuating lever are checked for elongation, and the roller that makes contact with the plunger is checked for smoothness and freedom from nicks and flat spots. Test springs for free length and test length versus test load in accordance with the spring data table provided in the O3 manual.

Reassembly

Before reassembly, immerse all internal parts in filtered, clean hydraulic fluid. Parts are reassembled while they are still wet. Reassembly is accomplished in the reverse order of disassembly. Upon completion of reassembly, adjust the lever backstop adjustment screw to the dimensions indicated in figure 14-21.

Testing

Figure 14-21 shows the operational test setup used to accomplish the variety of tests required to verify that the valve is ready for issue. A test stand capable of supplying hydraulic pressure from 0 to 4,500 psig pressure is required. Air is bled from the valve, and testing is conducted in accordance with the test procedures table provided in the MIMs and/or O3 manual. Tests include proof test, static pressure test, pressure drop test for internal leakage, and a complete operational test to verify power operation and adjustment. A test troubleshooting table can be found in the "Intermediate Repair" section of most MIMs and O3 manuals. Tables may be used to assist in isolating causes for malfunctions that result from repair action.

After testing, fill the valve with preservative hydraulic fluid and plug all ports. Lockwire the lever backstop adjustment screw, the plunger end cap, and the end plug in the manner recorded before disassembly.

POWER/MANUAL BRAKE VALVE

There is no daily or routine maintenance required on the power/manual brake valve other than a wipe down of the exposed portion of the rod. There are,

however, certain repairs that can be effected in case of valve malfunction. These include replacement of seals, as required, tube, shaft, springs, or even the body in more serious cases.

Tests are not required on the individual valve parts. After disassembly, cleaning, inspection, repair or replacement, lubrication, and complete reassembly have been accomplished, perform a bench test. This test will determine whether the unit satisfies the required minimum specifications.

Test the power/manual brake valves on a test bench before installation in the aircraft. The test bench must be capable of supplying hydraulic fluid filtered through a 3-micron filter at a maximum pressure of 2,250 psi. During the test the room temperature should be 70° to 90°F, and the fluid temperature 70° to 110°F.

The bench test is divided into the manual section and the power section. No particular sequence of performance of bench test is required, except that the proof pressure test of a section must precede the leakage test of that section. Bleed all air from the unit before it is tested.

Proof Pressure Test—Manual Section

For this test the valve shaft must be harnessed in the midposition (1-inch plunger stroke), and the RETURN port must be plugged. Apply hydraulic pressure of 2,250 psi to the BRAKE port. There should be no evidence of external leakage, permanent distortion, failure, or malfunction of any part of the valve.

PUMPING TEST.—To perform the pumping test, you should connect a reservoir to the RETURN

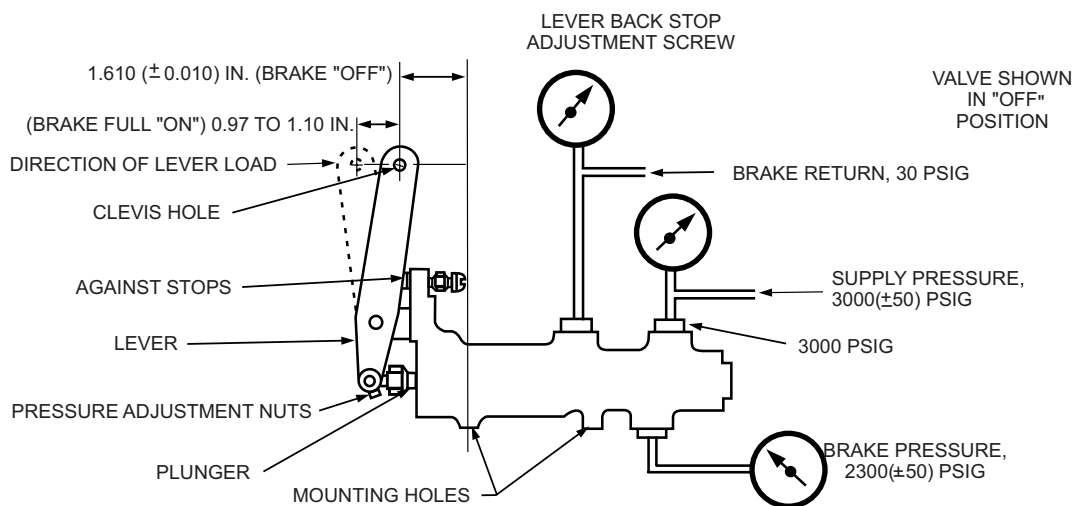

Figure 14-21.—Operational test setup—power brake valve.

AMf14021

port by means of a 3/8-inch ID hose that is at least 24 inches long. Position the reservoir in such a way that the fluid is above (but not more than 6 inches) the RETURN port. Move the shaft to the fully actuated (2-inch plunger stroke) position, and then cap the BRAKE port.

To perform the pumping test, cycle the valve rapidly. A rapid decrease in the length of successive pressure strokes should be noted. On each cycle the return stroke should be self-motivated.

LEAKAGE TEST.—Reposition the unit on the bench and harness the valve shaft in the midposition. With the RETURN and PRESSURE ports open, hydraulic pressure of 25 psi should be applied to the BRAKE port. There should be no evidence of external leakage, failure, or malfunction of any part of the valve. After the first minute, leakage at the RETURN port should not exceed 1 cubic centimeter per minute for 2 minutes. If satisfactory at this stage, repeat the procedure by using 500 psi at the BRAKE port.

With the valve in the relaxed position, apply static hydraulic pressure of 5 psi to the BRAKE and RETURN ports. There should be no external leakage, failure, or malfunction of any part of the valve. Repeat the procedure with 200 psi of static hydraulic pressure.

Proof Pressure Test—Power Section

A pressure of 2,250 psi should be applied to the PRESSURE port with the BRAKE and RETURN ports open. Maintain the pressure for 2 minutes, and then look for evidence of external leakage, failure, or permanent set. Perform this step twice.

OUTPUT PRESSURE TEST.—This test is performed in three stages. Apply hydraulic pressure of 1,500 psi to the PRESSURE port, and apply successive plunger loads of 47 pounds, 124 pounds, and 190 pounds. As a result of these applications, the pressure output readings at the BRAKE port should be 100 to 160 pounds on the first load, 660 to 750 pounds on the second load, and 1,135 to 1,255 pounds on the third load.

LEAKAGE TEST.—The leakage test for the power section requires 1,500 psi of hydraulic pressure at the PRESSURE port with the BRAKE and RETURN ports open. With the valve shaft in the relaxed position, the combined leakage from the open ports should not exceed 25 cubic centimeters per minute for the last 4 minutes of a 5-minute period. If the unit checks out, proceed to the next step.

With 1,500 psi still applied to the PRESSURE port, plug the BRAKE port, and then extend the valve shaft to midposition. Leakage from the RETURN port should not exceed 25 cubic centimeters per minute for the last 4 minutes of a 5-minute period.

FLOW TEST.—To perform the flow test, you should apply hydraulic pressure of 1,500 psi to the PRESSURE port. Move the plunger between 3/8 and 5/8 of an inch. Minimum flow at the BRAKE port should be 2 gpm, and there should be no evidence of chatter or instability.

After testing is completed, remove the valve from the test bench, flush it with hydraulic preservative oil, drip-drain the unit, and plug all ports. The body should be rubber-stamped with the cure date of the oldest O-ring or packing and tagged with the date of the test and the results.

MASTER BRAKE CYLINDER

Maintenance at the organizational level consists of removal and replacement of the master brake cylinder. Maintenance at the intermediate level consists of disassembly, cleaning, inspection, repair and replacement of seals and parts, lubrication, reassembly, and testing.

Disassembly

Before disassembly, the “Intermediate Repair” section of the MIM or 03 manual should be used to make sure that all parts, material, equipment, and facilities required during repair are available.

WARNING

Before any removal, install an AN350-4 nut on the threaded end of the piston rod to bottom against the shaft bearing. This will eliminate the possibility of injury to personnel during disassembly because of spring preload.

Disassemble the cylinder according to the procedures provided in the “Intermediate Repair” section of the MIM and/or 03 manual. Place spring-loaded subassemblies in an arbor press or other device designed to restrain parts while relieving the tension.

Cleaning

Wash all reusable parts of the Gladden master brake cylinder with P-D-680 cleaning solvent. Use a

bristle brush to remove caked dirt from exterior surfaces. Use a piece of soft, copper wire to remove obstructions from ports and passages. Thoroughly dry all parts with a clean, lint-free cloth or 20-psi compressed air.

Inspection

Conduct the inspection of parts under a strong light and preferably with a means of magnification. Make the following checks:

1. Check all parts for nicks, cracks, scratches, and corrosion.
2. Check threaded parts for crossed or damaged threads.
3. Check all packing grooves for surface defects that might cut packings during installation or cause failure during operation.
4. Check the bearing on the suspension rod at the reservoir port end of the cylinder for freedom of rotation and evidence of flat spots.
5. Check all springs for specified load at given length. There should be no permanent set from test loading, and springs should not wobble when they are rolled across a flat surface.

Repair and Replacement

Polish minor nicks and scratches on metal parts with crocus cloth (Federal Specification P-C-458C for steel parts and P-C-451B for aluminum parts). During polishing, make sure that all dimensions are maintained within the specified limits and that seating and sealing surfaces are not damaged.

Repair damage to anodized finishes on aluminum parts by applying a protective chemical film per Specification MIL-C-81706, class 1A, Form III.

WARNING

Chemical film materials are strongly oxidizing and are a fire hazard when in contact with organic materials such as paint thinners. Do not store or mix surface treatment materials in containers previously containing flammable products. Rags contaminated with chemical film material should be thoroughly rinsed and disposed of as soon as practical.

When you replace a suspension bearing, stake the new bearing at the original stake points on both sides of the body by using a 3/16-inch-diameter ball in the

staking tool. Verify the security of the bearing, and inspect the area around the staking indentations for possible fractures.

Many parts for the repair of the Gladden master brake cylinder are provided in cure-date and overhaul kits. Replace all other worn or damaged parts that cannot be reworked to meet inspection requirements. Detail parts not provided in the kit may be available from bulk stock.

Lubrication

Apply a light coat of hydraulic fluid to all sealing devices to aid in reassembly. The recommended lubricant for the suspension rod end bearing is grease, Specification MIL-G-23827.

Reassembly

Reassemble all internal parts in reverse order of disassembly by using an arbor press, or equivalent, and an AN350-4 nut to aid in assembly and to eliminate the possibility of personnel injury because of preload of springs.

Testing

The test equipment required includes a conventional hydraulic test bench capable of delivering fluid to 4,500-psi pressure at room temperature, plus the equipment illustrated in figures 14-22 and 14-23. The nominal extended length of the unit from the center of the end bearing to the end of the actuating rod is 15.31 inches.

To proof test the inlet chamber and perform a leakage test, first apply 5 psi, and then 200 psi at the reservoir port with the brake port plugged. There should be no external leakage for 1 minute from either port.

To perform the piston, valve, and brake chamber proof test, install the unit in the jig (fig. 14-22), and

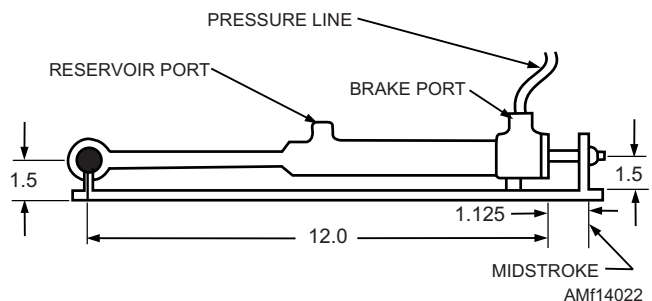

Figure 14-22.—Piston, valve, and brake chamber proof test setup diagram

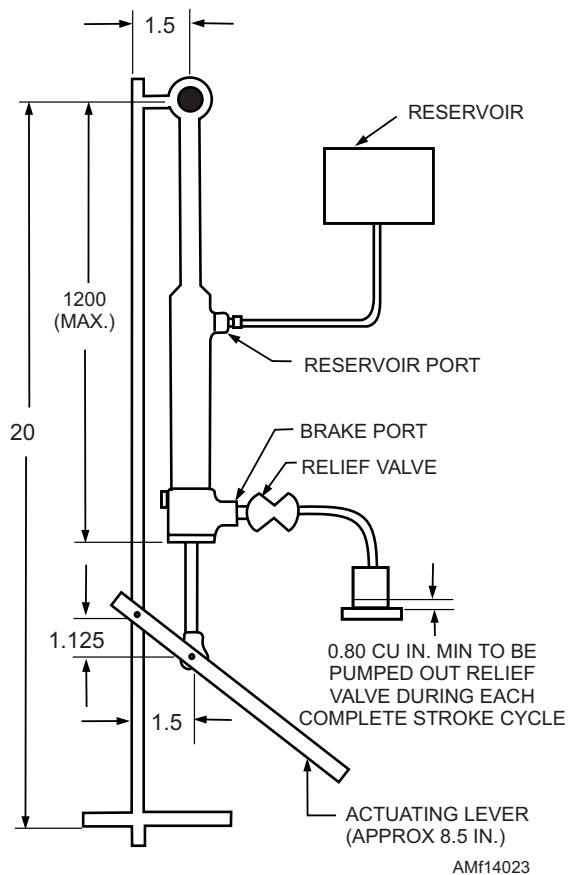

Figure 14-23.—Rod packing, cylinder leakage, and pumping function test.

harness it at the midstroke position with 25-psi hydraulic pressure applied at the brake port. There should be no external leakage. Leakage at the reservoir port should not exceed 1 drop per minute for 2 minutes after a 1-minute waiting period. If the unit tests satisfactorily at this stage, the pressure should be increased to 2,000 psi. There should be no external leakage, and leakage at the reservoir port should not exceed 1 drop per minute for 2 minutes after a 1-minute waiting period.

When the foregoing test is completed, the unit is ready to receive a rod packing, cycling leakage, and pumping function test. With the unit extended and installed in the actuating fixture, a reservoir should be connected to the reservoir port and a 200- to 400-psi relief valve should be connected to the brake port. See figure 14-23. Operation of the manual lever through five full strokes should pump hydraulic fluid through the relief valve. Leakage at the piston rod gland should not exceed 1 drop at this time. Not less than 0.75 cubic inch of fluid should flow from the relief valve during any one complete stroke cycle of the manual lever. There should be no evidence of binding at any time during these tests.

BRAKE SHUTTLE VALVE

Shuttle valve maintenance is generally limited to repairing leakage. External leakage may usually be repaired by tightening the end caps. If this does not stop the leakage, the end cap O-ring should be replaced.

Internal leakage can usually be repaired by removing and flushing the unit with clean, hydraulic fluid. Excessive heating is a good indication of internal leakage through a shuttle valve. Excessive cycling of the emergency system pump is also an indication of a leaky shuttle valve.

After an emergency system has been operated, all emergency system pressure should be bled off as soon as possible and the normal system restored to operation.

AUTOMATIC BRAKE ADJUSTER VALVE

Tests are not required on the individual adjuster valve parts. After disassembly, cleaning, inspection, repair or parts replacement, and complete reassembly have been accomplished, perform a bench test to determine whether the brake adjuster valve satisfies the required minimum specifications.

Disassembly

The brake adjuster valve should be disassembled in accordance with instructions contained in the MIM and/or 03 manual. Check the safety wiring before disassembly to expedite rewiring after reassembly.

Cleaning

Clean all parts except the nylon insert and O-rings with P-D-680 cleaning solvent. The insert and O-rings will normally be replaced upon each disassembly of the valve. Dry parts with dry, clean, filtered, compressed air.

WARNING

Do not inhale solvent vapors or direct compressed air against the skin. Failure to observe proper safety precautions could result in injury to personnel.

Inspection

Perform inspections under a strong light and with magnification. Inspect all threads for crossed, filled, or

stripped conditions. Inspect all parts for nicks, scratches, scoring, corrosion, or other damage. Check all drilled passages for obstructions.

Repair or Parts Replacement

Replace any part that is damaged or does not function properly. During replacement and before actual reassembly, lightly coat all parts with hydraulic preservative fluid; assemble parts while they are wet.

Reassembly

Reassembly is essentially the reverse of disassembly. Directions for reassembly are provided in the MIM and/or O3 manual.

Bench Test

The bench test consists of a series of tests—proof pressure, thermal crack, shuttle valve opening operation, shuttle valve closing operation, and leakage. Perform these tests in the order listed on a test bench, and not while they are installed in the aircraft. The test bench used must be capable of supplying hydraulic fluid filtered through a 3-micron filter at a maximum pressure of 2,250 psi. Conduct the tests at a room temperature of 70° to 90°F and a fluid temperature of 70° to 110°F. Before you start the test, bleed all air from the unit. After completing the test, remove the valve from the bench. Flush with hydraulic preservative fluid, drip-drain, and plug the ports. The cure date of the oldest sealing device should be rubber-stamped on the body of the valve, and the unit tagged with the date and results of the test.

To perform the proof pressure test, apply a hydrostatic proof pressure of 2,250 psi to the RET (return) port with the BRAKE and PMV (power/manual valve) ports interconnected. Apply this pressure twice and hold for a 2-minute period each time. There should be no evidence of external leakage, failure, distortion, or permanent set.

Perform the thermal crack test by applying pressure gradually to the BRAKE port with the RET and PMV ports open until the valve cracks. The residual pressure should not be less than 27 psi. Again, gradually increase pressure at the BRAKE port until the valve cracks. The cracking pressure should be between 30 and 37 psi. There should be no leakage from the PMV port.

NOTE: During piston travel a volume of fluid will be displaced through the PMV port. Only the portion of displaced fluid that exceeds 10 cubic centimeters should be considered as leakage. No RET port fluid displacement should be considered leakage.

This procedure completes the thermal crack test. In preparation for the shuttle valve opening operation test that follows, block residual pressure in the BRAKE port using a pressure gauge as the plug.

With the RET port open and BRAKE port capped, apply hand-pumped hydraulic pressure gradually to the PMV port. There should be a simultaneous increase of BRAKE port pressure with PMV port pressure. At a pressure of 60 to 80 psi in the PMV port, pressure in the PMV port and BRAKE port should become equal. A gradual increase in PMV port pressure to 1,500 psi should result in a proportionate increase in the BRAKE port pressure. Any displacement at the RET port should not be considered leakage during this phase of the bench test.

The shuttle valve closing operation test begins with 1,500 psi from the previous phase still applied to the PMV port. Reduce the pressure at the PMV port to 150 psi, and then rapidly to 0 psi. The closing operation is evidenced by the venting of hydraulic fluid from the RET port as PMV pressure decreases from 20 psi to 0 psi.

The final phase of the bench test is the test for leakage. This phase is started with 27-psi hydraulic pressure trapped in the BRAKE port. There should be no evidence of pressure decrease when it is measured over a period of 3 minutes. Continue the test with the BRAKE port capped and the RET port of the valve in an upright position. Fill the RET port cavity and a leakage measuring device with hydraulic fluid. Apply hand-pumped hydraulic pressure of 30 to 37 psi to the PMV port. Leakage at the RET port must not exceed 0.5 cubic centimeter per minute. Immediately after application of pressure, measure the leakage for a 3-minute period. Disregard volume displacement because of shuttle valve transition if leakage is not in excess of 0.5 cubic centimeter per minute. Increase the pressure to 125 psi and maintain for a 3-minute period. There should be no evidence of leakage. Further increase the pressure to 1,500 psi and maintain for another 3-minute period. There should be no leakage.

BRAKE SELECTOR VALVE

Repair of the brake selector valve at the intermediate level of maintenance is limited to the

replacement of cure-date items and parts listed under Spares and Replacement Parts Data in the "Intermediate Maintenance" section of the MIM.

Figure 14-24 shows an exploded view of the selector valve. Observe the arrangement in which the machine screws are lockwired to aid in reassembly. Disassemble the valve and clean all parts with P-D-680 cleaning solvent. Dry all parts thoroughly, using low-pressure, moisture-free, compressed air or a lint-free, clean cloth. Inspect all parts for scratches, cracks, scoring, burrs, nicks, excessive wear, and distortion. If any part other than those listed in the Spare and Repair Parts Data is faulty, the component must be tagged to show the fault and forwarded to the next higher level of maintenance.

Replace all sealing devices and worn or damaged parts. Apply a light coating of hydraulic fluid on all O-rings, backup rings, seals, and wear surfaces before reassembly. Note the proper assembly of the seal, O-ring and backup ring, and the proper assembly of the

stop plate, as shown in figure 14-24. Reassembly is essentially the reverse order of disassembly. Steps that require quality assurance verification in the MIMs are identified by the letters "QA" after the applicable steps. When QA is assigned to a step or a heading that is immediately followed by substeps, the inspection is applicable to all substeps. The four machine screws that hold the selector valve assembly together must be tightened and properly lockwired.

NOTE: In some MIMs, the steps in a procedure that require a QA inspection are underlined or italicized.

Bench test the repaired valve to verify its ready-for-issue (RFI) condition. The hydraulic fluid used to test the valve must be continuously filtered by a 3-micron absolute, nonbypass filter upstream of the valve. Allow the test stand fluid to reach an operating temperature of 70° to 110°F before the testing begins. The valve must pass a proof test, static pressure test, actuation (operational) test, and leakage tests. During

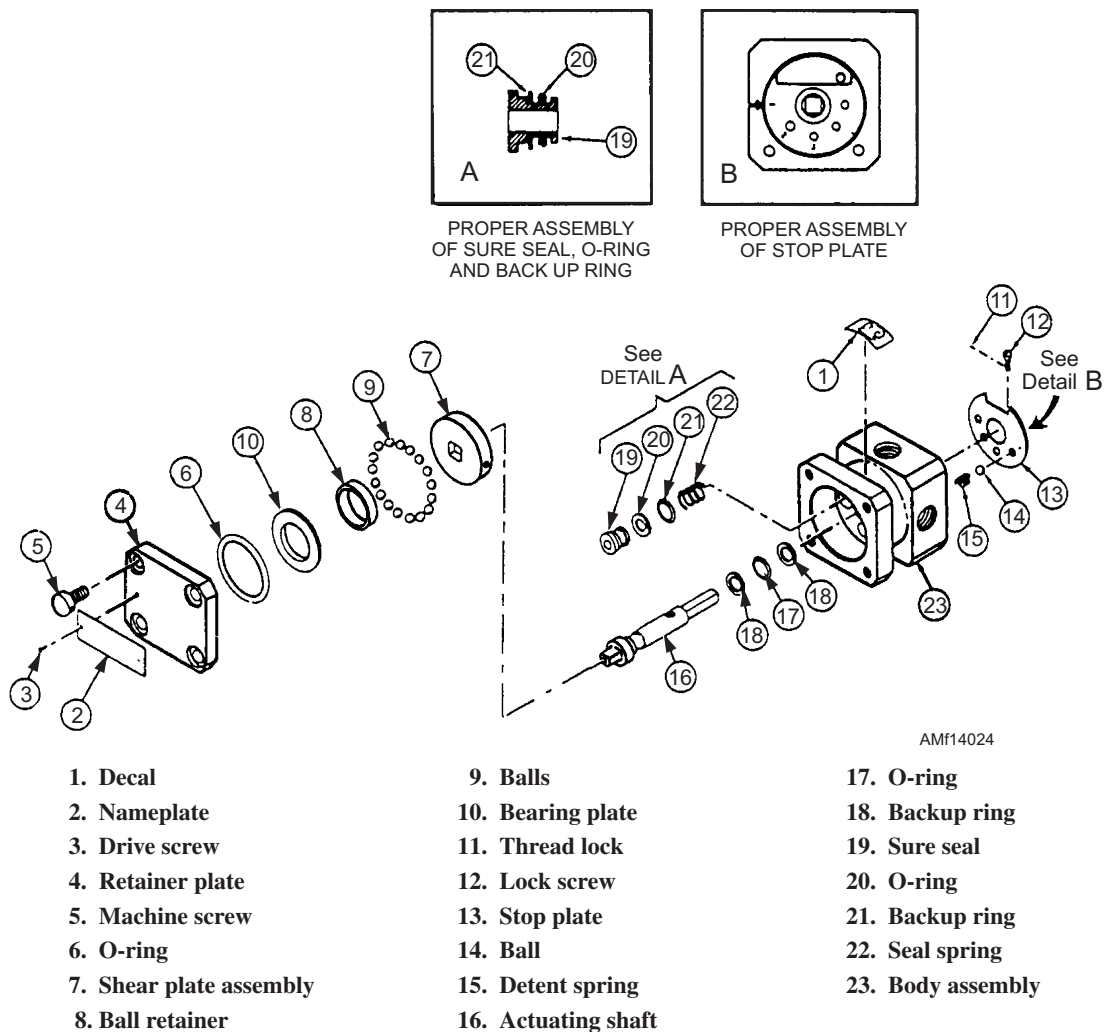

Figure 14-24.—Brake selector valve—exploded view.

the actuation test, the amount of torque required to operate the valve to any position should not exceed 40 inch-pounds with 3,000 psi applied to the pressure port. The requirements for each test are specified in the "Intermediate Repair" section of the MIM.

SWIVEL MAINTENANCE

Organizational maintenance of the swivel, shown in figure 14-25, consists of removal and replacement. Intermediate maintenance is limited to replacement of materials provided in the cure-date seal kit and the retainer. When you assemble swivels of this type, gently push the outer body over the inner body with a slight oscillating motion to prevent damage to the O-rings and backup rings. A light coating of hydraulic fluid is applied to all O-rings, backup rings, and mating surfaces before it is reassembled. Following reassembly, the swivel is bench tested.

Proof testing is accomplished by applying 4,500 psi individually to each port with the opposing port plugged. Maintain the pressure for 2 minutes, and there should be no leakage. Conduct this check a minimum of three times, and during the last proof test, rotate the swivel through a complete swiveling circle.

Conduct the static leak test in the same manner as the proof test using 5 to 10 psi. Next, apply 3,000 psi to both the normal and emergency ports with the opposing ports plugged. Gradually, apply and check the torque required to rotate the swivel. Maximum torque required should not exceed 30 inch-pounds.

In the final step of testing, apply low pressure to each port with the opposing port unplugged, and check to ensure that fluid flows freely through the swivel. If the swivel is RFI and is to be returned to supply for stock, flush it with preservative hydraulic fluid and plug all ports. If the part fails the testing, tag it to show the part of the test failed. Flush with preservative hydraulic fluid and plug the ports. Forward the part to supply to be forwarded to the next higher level of maintenance.

Q14-25. After a brake reservoir has been cleaned and cure-date parts have been installed, how many minutes should the reservoir be submerged in a tank of water to check for leaks?

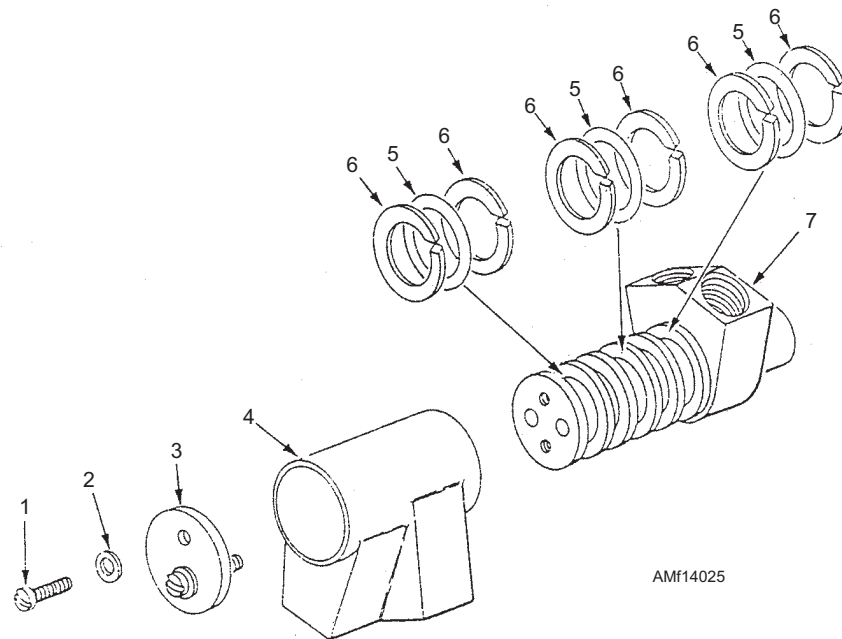

- 1.Screw
- 2.Washer
- 3.Retainer
- 4.Outer body
- 5.O-ring
- 6.Backup ring
- 7.Inner body

Figure 14-25.—Brake swivel.

- Q14-26. What substance should all internal parts of the power brake valve be immersed in before reassembly?
- Q14-27. How much hydraulic test stand pressure is required to perform an operational test on a power brake valve?
- Q14-28. What fluid should be applied to all sealing devices during reassembly of the master brake cylinder?
- Q14-29. What device should be installed on the end of a piston rod before disassembling a master brake cylinder to prevent personal injury due to preload of the springs?
- Q14-30. What letters are used after the applicable step to identify steps that require quality assurance verification in the Maintenance Instruction Manual (MIM)?

BRAKE ASSEMBLY MAINTENANCE

LEARNING OBJECTIVE: Identify the maintenance procedures for the single disc, the dual disc, and the trimetallic disc brake assemblies.

The description and operation of the single disc, dual disc, multiple disc, and segmented rotor brake assemblies were covered earlier. Additional maintenance information on the single and dual disc brake assemblies and a description and operation of the trimetallic disc brake assemblies are covered here.

SINGLE AND DUAL DISC BRAKES

Automatically adjusted single and dual disc brakes are designed to provide a satisfactory running clearance between the brake disc and the brake linings. The self-adjusting feature of the brake maintains the desired lining and puck-to-disc clearance, regardless of lining or puck wear. See figure 14-26. When you apply the brakes, hydraulic pressure moves each piston and its pucks or linings against the disc or discs as applicable. As the linings wear, the piston pushes against the adjusting pin (through the spring guide) and moves the pin against the friction of the adjusting pin grip. When you release the brake pressure, the force of the return spring moves the piston away from the brake disc, but it does not move the adjusting pin, which is held by the friction of the pin grip. The piston moves away from the disc until it stops against the head of the adjusting pin. Thus, regardless of the amount of wear, the same travel of the piston will be required to apply the brake, and the running clearance will be maintained.

The automatic adjusting feature may be referred to as a captured torquing type or captured nontorquing type. Figure 14-27 shows a typical captured torquing-type automatic adjuster. It is mandatory that clearance be established between the linings and the discs before torquing the automatic adjusting nut to the amount specified for the brake involved. Otherwise, the brake will drag until an amount equal to the built-in clearance is worn from the face of the linings. With the adjusting nuts properly torqued, the friction between

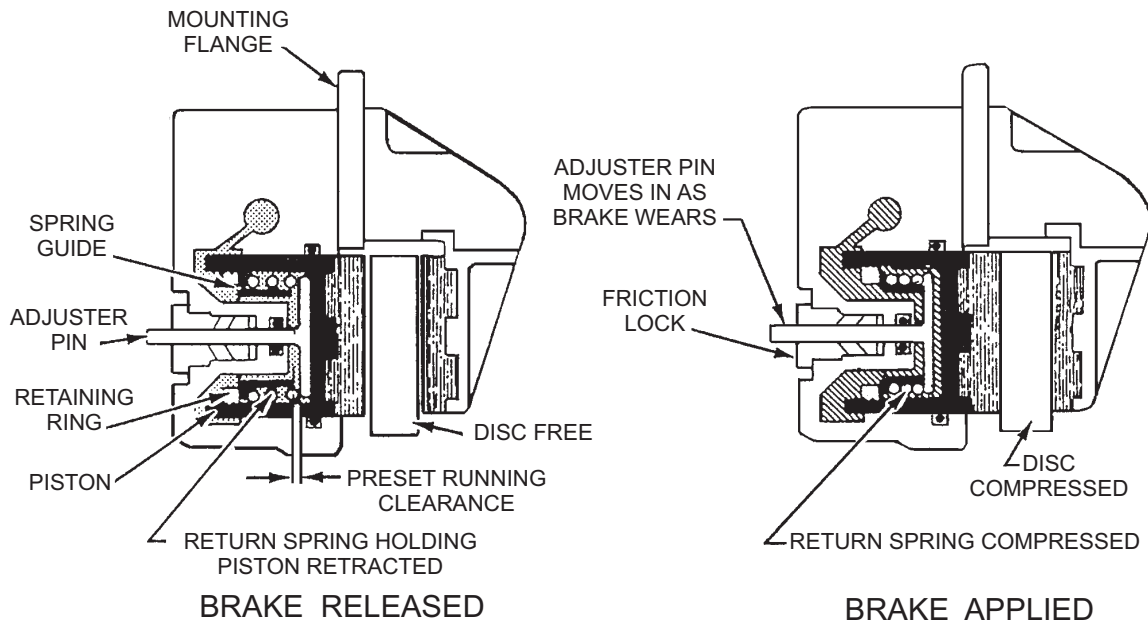

Figure 14-26.—Brake self-adjustment feature—single disc brake.

AMF14026

the grip and the adjusting pin is great enough to overcome the compression of the return spring, and the adjusting pin will be pulled through the grip only to compensate for lining wear.

After torquing the automatic adjusting nuts to the specified value, back them off and retorquing several times. This procedure will ensure proper mating of all parts and the correct torque on the final assembly.

Figure 14-28 shows the captured nontorquing-type automatic adjuster used on some single and dual disc brake assemblies.

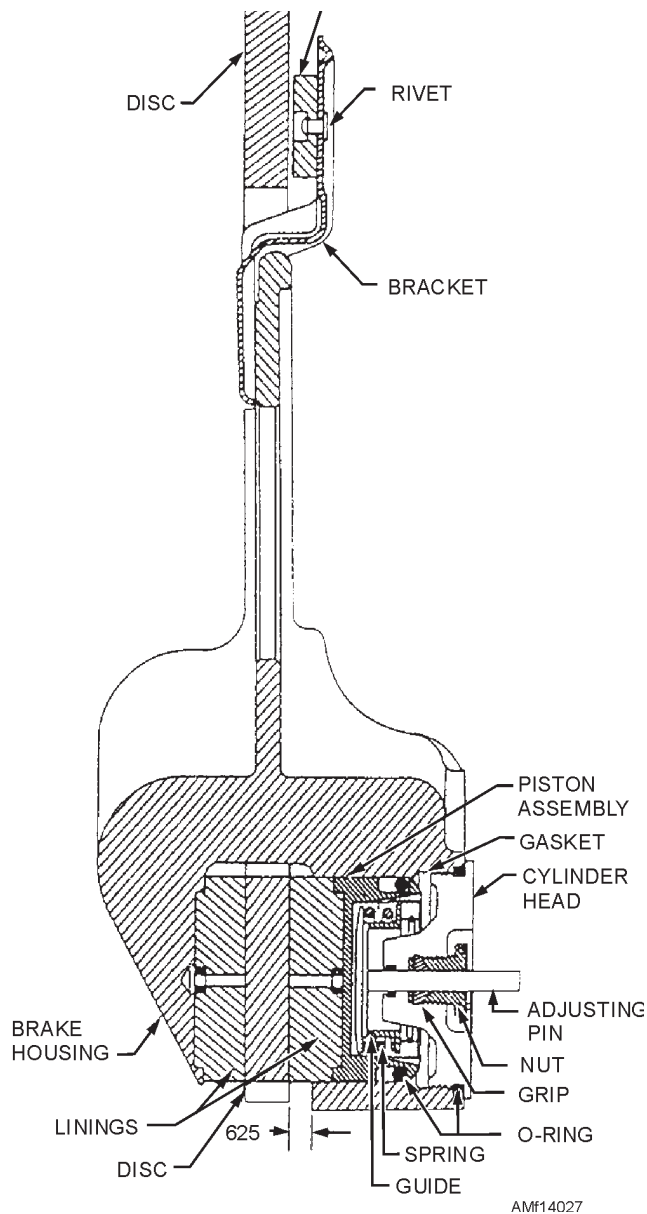
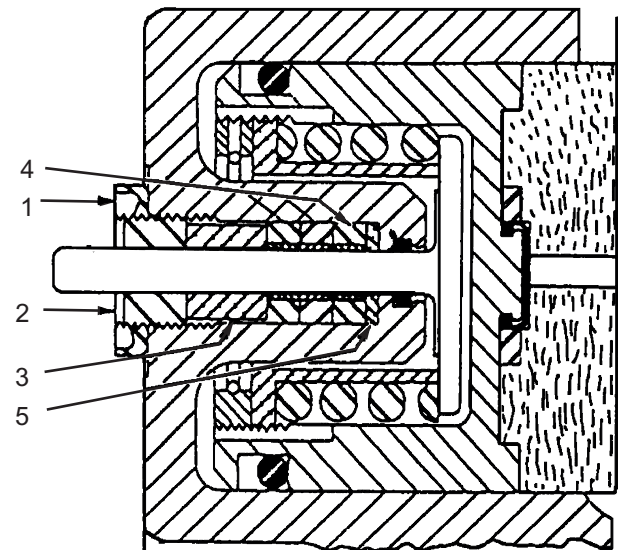

Figure 14-27.—Cross-sectional view of a single disc brake assembly with captured torquing-type automatic adjuster.



1. Locknut
2. Threaded bushing
3. Spacer
4. Grips, split collar
5. Washer

Figure 14-28.—Captured nontorquing-type automatic adjuster.

Brakes that contain nontorquing adjusters can be identified by the locknut and threaded bushing over each adjusting pin. The only difference between the torquing- and nontorquing-type automatic adjustment is the method used to restrict the movement of the adjusting pin. The torquing-type adjustment uses a tapered grip, and the nontorquing uses one or more 1/4-inch-wide grips composed of brass liners.

Spare grips are shipped with pilot pins installed to open the grip to the approximate diameter of the adjusting pin, thus preventing damage to the grip during installation. The pilot pin is expelled as the grip is forced over the adjusting pin. If grips are to be reused when a brake is disassembled, they should have the pilot pins reinstalled before assembly in the brake.

Brake repairs on the single disc brake consist of replacing linings, worn or damaged sealing devices, brake release units, or brake discs. See figure 14-29.

Lining replacement and cure-date kit installation consist of the following steps:

1. Remove the lockwire and unscrew the cylinder heads (brake release units); remove the release units from the housing.
2. Remove the disc from the brake housing.

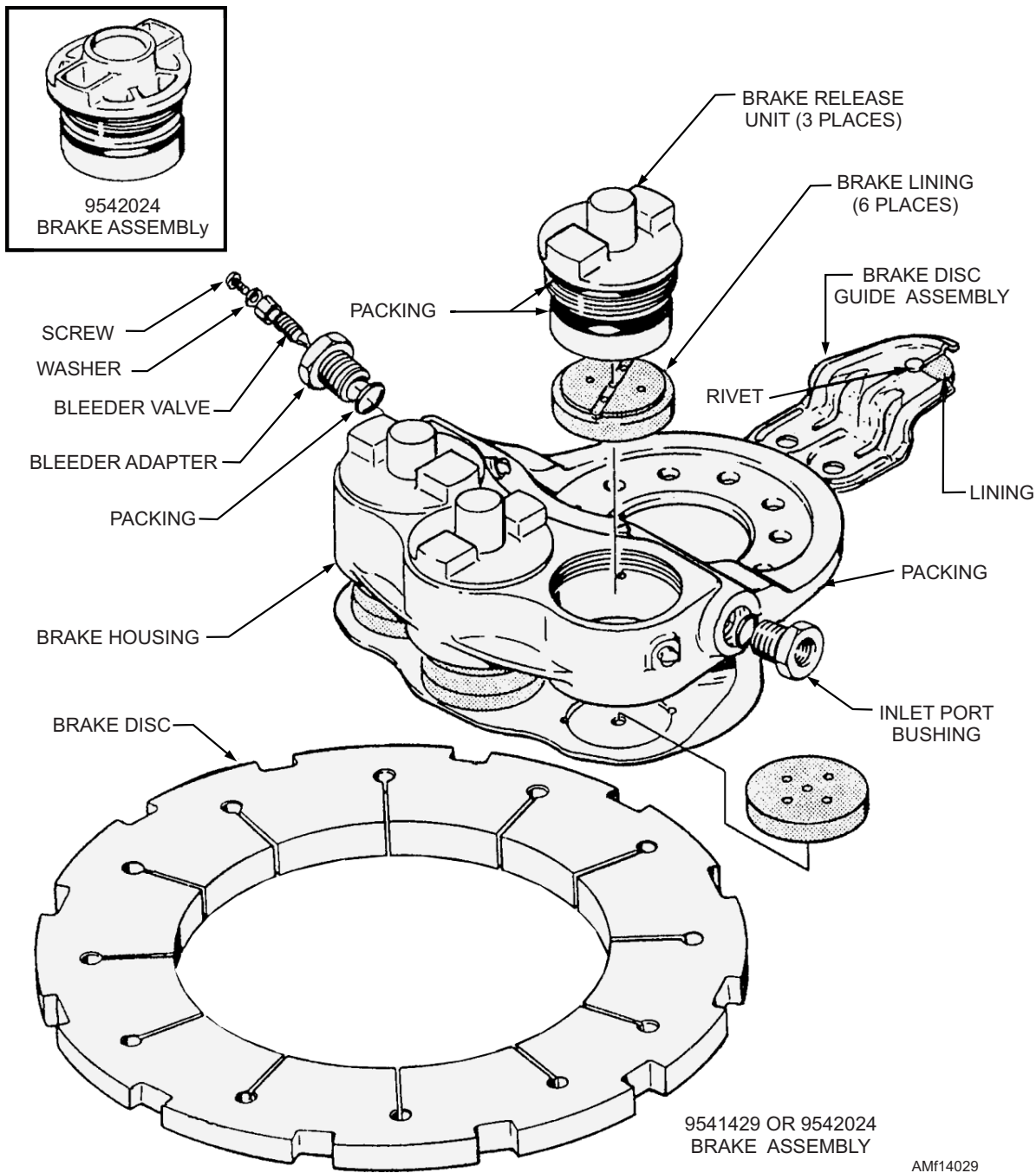

Figure 14-29.—Single disc brake—repair and parts replacement diagram.

3. Remove the inlet plug and bushing, the bleeder adapter, and O-ring packings.
4. Remove the brake linings from the pistons, the brake housing, and the disc guide.
5. Clean the brake assembly components with low-pressure compressed air. Wash all metal parts in P-D-680 cleaning solvent. Dry with compressed air.
6. Check the release units for damage, nicks, and gouges. If damaged, replace the complete release unit.
7. Check the brake housing for cracks and cylinder walls for nicks or other visible damage. Damage will necessitate turning in the complete brake assembly to supply for disposition.
8. Install new linings in the housing cavities and rivet on the disc guide lining. Friction fit will hold the linings in the housing cavities. Do NOT use cement.
9. Install new linings in the piston cavities using brake lining adhesive specified for such use (for example, Pliogrip No. 3).

10. Install the brake disc into the brake housing.
11. Dip brake release unit packings from the cure-date kit into the hydraulic fluid and install on the brake release units.
12. Coat the piston of the release unit with a light coating of hydraulic fluid and install in the housing. Tighten the cylinder heads against the housing as specified in the MIM or the 03 manual.
13. Reinstall the inlet plug, bushing, and bleeder adapter into the housing. Use new packings that have been dipped in hydraulic fluid.
14. Lockwire the cylinder heads, bleed the brake, and test the brake for leakage and proper operation. Test pressure for this brake assembly is 1,100 psi. Hold the pressure for 2 minutes and check the assembly for leaks. Release and reapply the pressure 10 times, and check for proper brake operation and release of the discs. Allow the brake to stand 2 minutes with pressure relieved to check for static fluid leakage.

On dual disc brakes, as well as some single disc brakes, the linings may be replaced without disturbing the brake hydraulic system. See figure 14-30. In this example, the shock strut is raised with a wheel jack until the wheel is clear of the ground. The wheel is removed, and the four internal wrenching bolts that attach the brake housing to the backplate are removed. The two setscrews located at each side of the brake housing are unscrewed enough to allow removal of the seven axle flange attaching bolts. Make certain the brake assembly is supported before you remove the bolts, or damage to the brake hose could result. Remove the brake linings from the pistons, center carrier, backplate, and disc guide. Riveted linings must be drilled. Snap-on or friction-fit linings can be easily pried off with a common screwdriver. Remove dirt and other foreign particles from the brake assembly components by the use of low-pressure compressed air. Wear safety eye protection during this operation.

Clean the external surfaces of the brake parts with a cloth dampened with P-D-680 cleaning solvent. Replace any brake lining attaching buttons that are damaged. The housing, backplate, center carrier, and all bolts should be inspected for damage, cracks, or leakage, as applicable. If the brake has hydraulic leakage or if the housing, backplate, or center carrier is damaged or cracked, the complete brake assembly should be replaced and turned in to supply for repair at the next higher level of maintenance.

Inspect the disc for minimum thickness, maximum width of the keyways, and warping. Check the disc for warpage by using a straightedge across the face of the disc. Instructions for straightening a warped disc can be found in the applicable 03 manual. Replace a brake disc that is worn excessively.

When a brake disc keyway is worn excessively or elongated, inspect the brake disc drive keys within the wheel assembly for damage and security. Replace the drive keys or the wheel if the damage exceeds the limitations specified in the applicable MIM.

The new linings are installed in the brake pistons, the center carrier, and the backplate. The disc guide lining is riveted to the disc guide. The pistons are pushed back into the piston housing until a maximum of 1/8 inch of lining is protruding beyond the housing. Assemble the brake on the axle flange, and torque all attaching bolts as well as the four internal wrenching bolts to the specifications provided in the MIM. The fore and aft axle attaching nuts on the brake housing must have their flat surface toward the setscrew on the final torque. The setscrews are tightened against the flat surfaces to safety the nuts. Secure the four internal wrenching bolts with lockwire. The wheel is installed and the shock strut lowered. Perform an operational check to verify proper operation. Specified steps throughout the lining and disc replacement procedures and the final security of all attachments require quality assurance verification as indicated in the MIM.

Figure 14-31 shows the various steps involved in replacing the piston seals and adjusting the return mechanism. The internal wrenching bolts holding the cylinder housing to the carrier and backplate are removed (view A). The cylinder housing is placed under a press, as illustrated in view B. Use the press and the drive pin to force the adjusting pins through their grips and remove the pistons from the housing. Make sure that the drive pin is centered on the adjusting pin to prevent damaging the adjusting pin packings and grips.

Next, cut the lockwire on the locknut. Use the threaded bushing wrench, illustrated in view C, to remove the locknuts, bushings, spacers, and grips from the housing. Remove the spring retaining ring from within the piston, as shown in view D.

With the linings still attached to the pistons, support the pistons in a press. Use a 3-inch length of 7/8-inch steel tubing to force the guides to the bottom on the adjusting pins, as shown in view E. Hold the guides in the bottomed position and turn the threaded

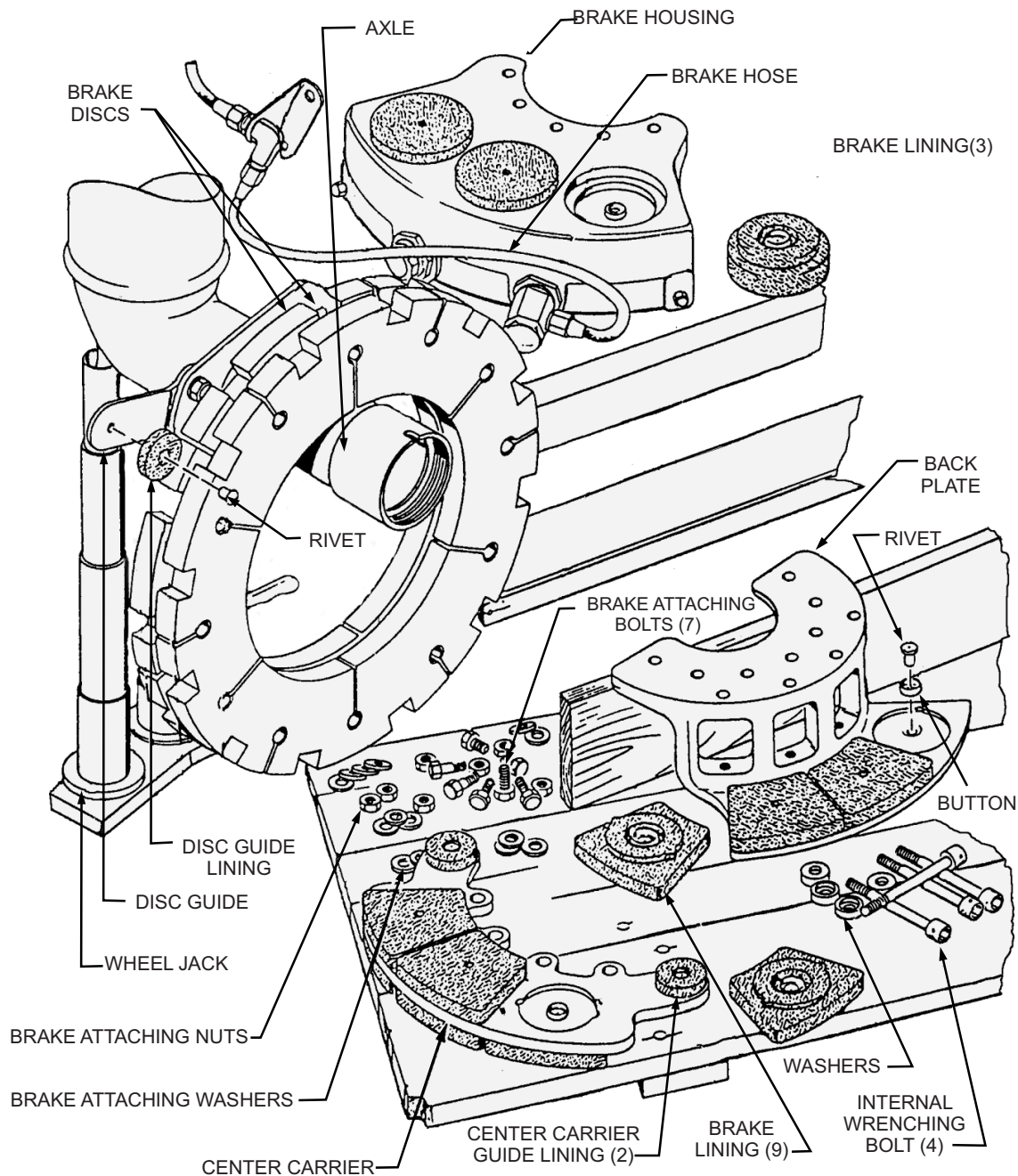

9541299 BRAKE ASSEMBLY

AM14030

Figure 14-30.—Dual disc brake—repair and parts replacement.

retaining rings clockwise until the rings are snug against the bottom guides. Back off the threaded retaining rings 3/4 of a turn counterclockwise from the bottomed positions and, if necessary, continue turning counterclockwise to the next locking position, as shown in view F. Secure the threaded retainer with the wire retaining ring.

Replace the piston packings with new packings that have been dipped in hydraulic fluid, and ensure that the packings and adjusting pin stems are lubricated with hydraulic fluid.

The piston assemblies are then installed in the cylinder housing and forced to the complete brake-off positions—bottomed in the housing cavities. The pistons are supported against their linings to the brake-off position. Use the press and the grip driver, as illustrated in view G, to force the grips, one at a time, over the adjusting pins until they are bottomed. The pistons must remain in the complete brake-off position when the grips are installed. Place the spacers over the adjusting pins and install the bushings fingertight. Hold the bushings in fingertight positions and install

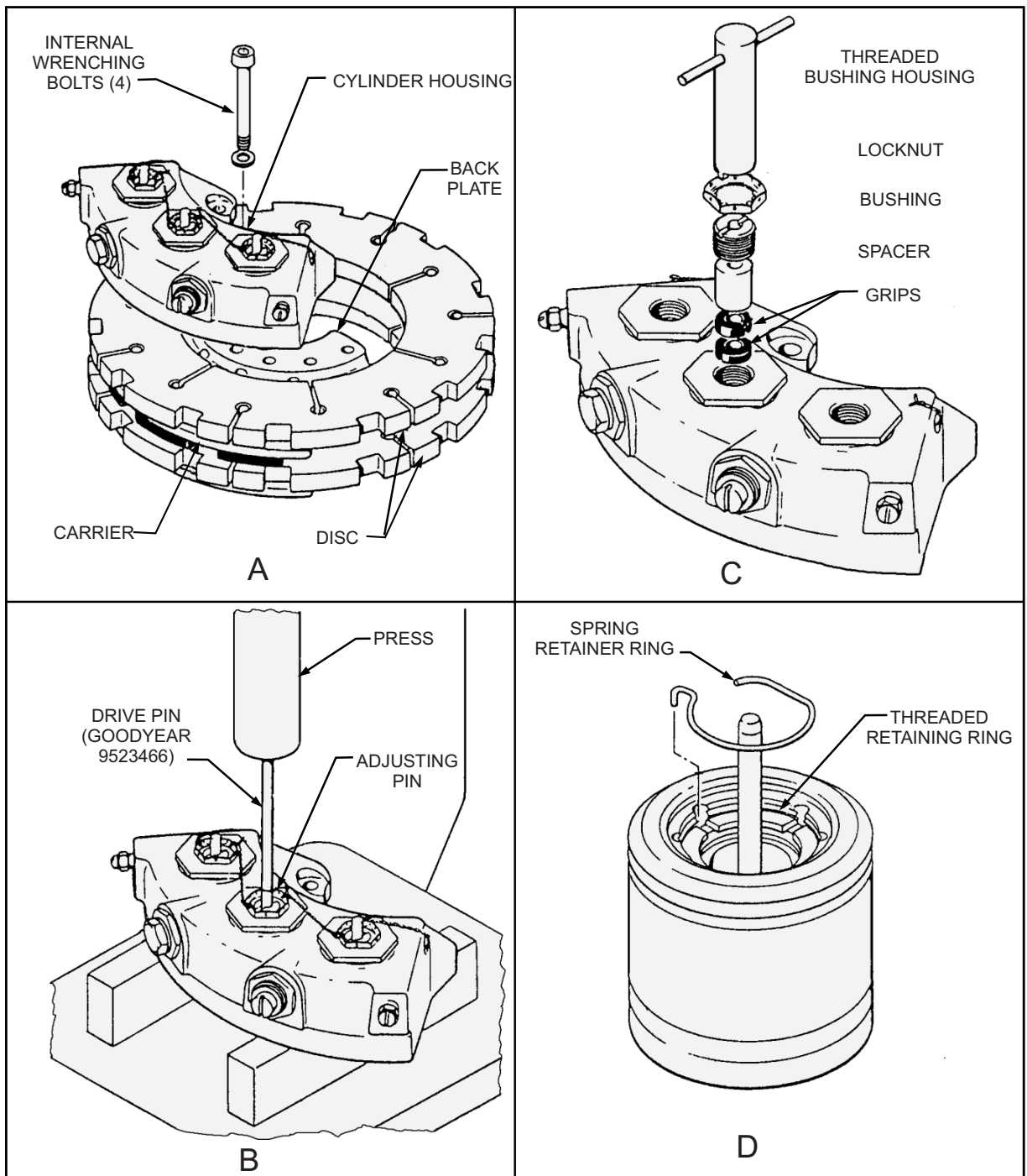

AMf14031a

Figure 14-31.—Seal replacement and piston return adjustment.

and tighten the locknuts. Safety wire the locknuts, as shown in view H.

NOTE: On some brake assemblies, the adjusting pin bushing (adjusting pin nut) is torqued to a specified value.

The brake assembly must be tested following reassembly. Connect the brake assembly to a hydraulic supply source. Bleed the brake assembly and apply 600 psi.

CAUTION

Before applying pressure, make sure that the brake is assembled properly with all bolts torqued and brake discs in position. Failure to do so could result in injury to personnel.

Hold the test pressure for 2 minutes while you are checking the brake assembly for leaks. Release and apply the pressure 10 times to be sure that the brake

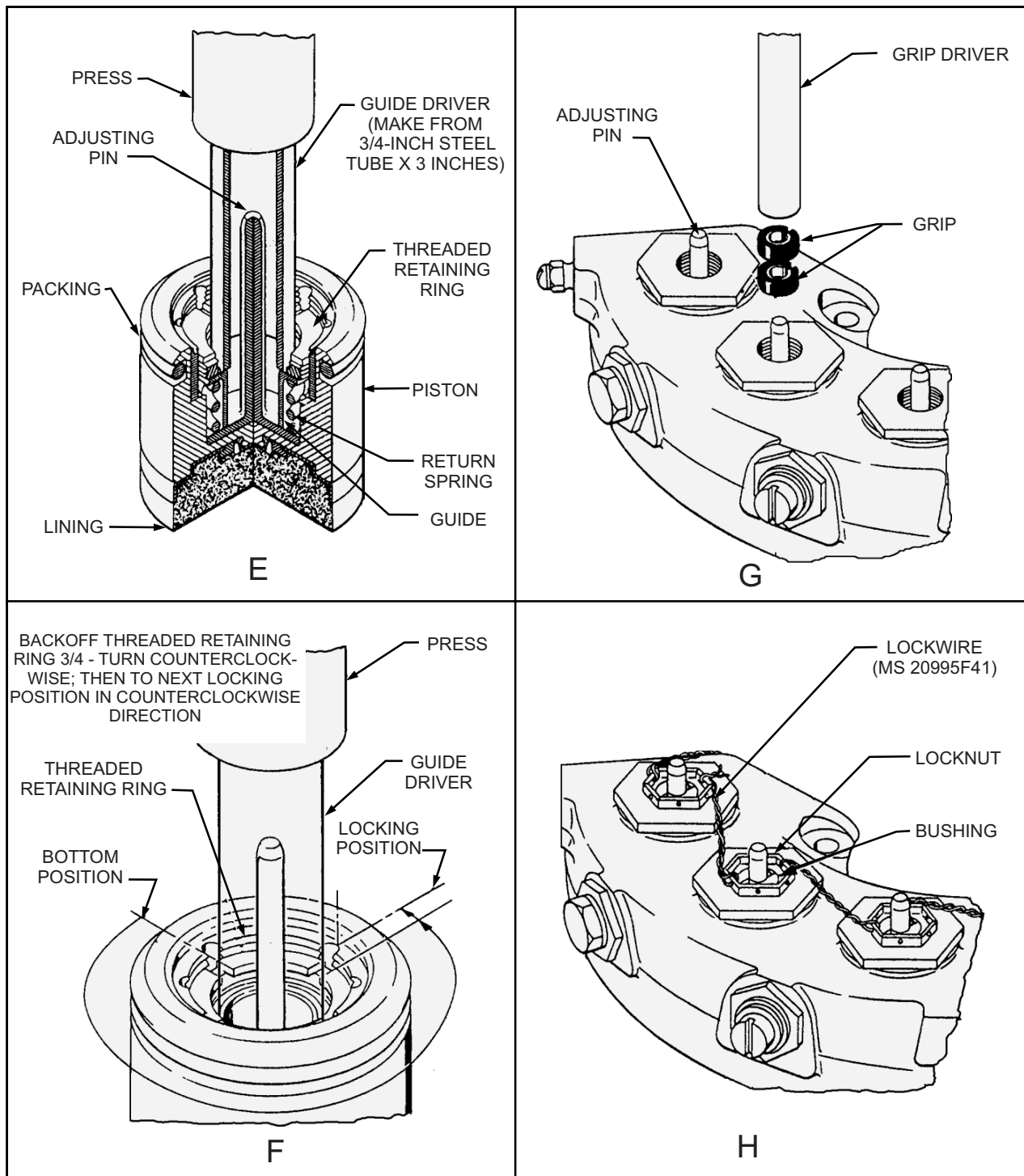

AMf14031b

Figure 14-31.—Seal replacement and piston return adjustment—Continued.

functions properly. The brake discs should be free when hydraulic pressure is released. Allow the brake to stand for 2 minutes with pressure released and check for static fluid leakage.

If the brake assembly is not to be installed immediately, install any attaching hardware that is part of the assembly, fill with preservative hydraulic fluid, and cap or plug all openings to prevent contamination.

TRIMETALLIC DISC BRAKES

Figures 14-32 and 14-33 show a typical trimetallic brake assembly. The trimetallic brake assembly consists of a brake housing subassembly, a keyed torque tube and torque tube spacer, a housing backplate, stationary and rotating discs, and a pressure plate subassembly.

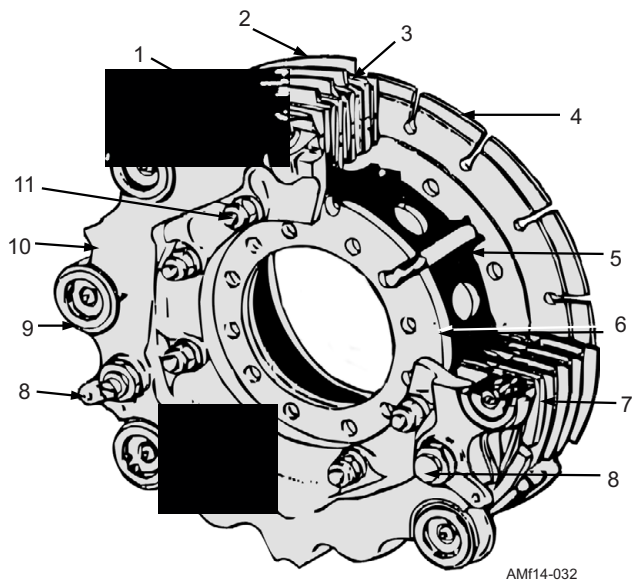

- | | |
|-----------------------|-------------------------------|
| 1. Bleeder valve | 7. Pressure plate subassembly |
| 2. Rotating disc | 8. Brake inlet port |
| 3. Stationary disc | 9. Self-adjusting mechanism |
| 4. Housing backplate | 10. Brake housing subassembly |
| 5. Keyed torque tube | 11. Brake assembling bol |
| 6. Torque tube spacer | |

Figure 14-32.—Trimetallic brake assembly.

Description

The brake housing subassembly, keyed torque tube and spacer, and the housing backplate are bolted together to form the basic brake assembly. The remaining components of the brake assembly are mounted over the keyed torque tube and between the brake housing and the housing backplate. The metallic-faced rotating discs have keyways that engage drive keys in the wheel so that they rotate with the wheel.

The rotating discs are separated by the stationary discs, which are keyed to the torque tube. The mating surfaces of these rotating and stationary discs constitute the major friction-braking surfaces of the brake. Additional friction surfaces exist between the outer face of one rotating disc and the housing backplate, and between the outer face of the rotating disc at the opposite end and the pressure plate subassembly.

The pressure plate subassembly consists of the pressure plate, replaceable wear plate, and wear plate insulator. These three parts are riveted together. The pressure plate serves as a seat for the self-adjusting

pins of the self-adjusting mechanism, and rests against the insulators installed in the outer ends of the brake pistons. It is the component through which force is directly transmitted during application and release of the brakes. The wear plate is keyed to the torque tube to prevent rotation of the complete subassembly, and serves as the friction surface for the outer face of the adjacent rotating disc. The wear plate insulator prevents brake heat from being transferred to the pressure plate and the brake pistons.

The brake pistons transmit hydraulic pressure through the pressure plate subassembly to the brake discs. Standard O-rings and backup rings around each piston prevent hydraulic fluid leakage and entry of contaminants. The pistons are further protected against heat transfer from the pressure plate subassembly by individual insulators installed in the ends of each piston where it contacts the pressure plate.

Self-adjusting mechanisms are located around the brake housing. They accomplish normal release of the brake and provide a continuing adjustment action to compensate for brake wear. Each mechanism consists of a self-adjusting pin, a spring housing and bushing, a return spring guide, a retaining ring, a grip and tube subassembly, and a self-locking nut. The grip and tube subassembly mounts over the self-locking pin, with the grips being installed firmly on the tube. As disc wear occurs, automatic adjustment is provided by movement of the adjusting pins through the split collar grips. The retaining ring inside the spring housing serves as a stop and retainer for the spring guide, which, in turn, holds the return spring in position. The head of the self-adjusting pin engages the pressure plate subassembly to allow brake release when pressure is removed.

Operation

When the landing gear wheel is rotating, the metallic-faced rotating discs of the brake assembly rotate freely between the stationary steel discs. When pressure is applied to the brake assembly pistons, the rotating and stationary discs are forced together, creating friction between their surfaces. The amount of hydraulic pressure applied to the brake pistons is controlled by the aircraft's brake metering system in response to the operating of the brake pedals. Braking action applied to the wheel brake is proportional to the pressure exerted on the brake pedal.

Pressure applied to the brake actuates all of the pistons within the brake housing. These pistons, in turn, force the pressure plate subassembly laterally

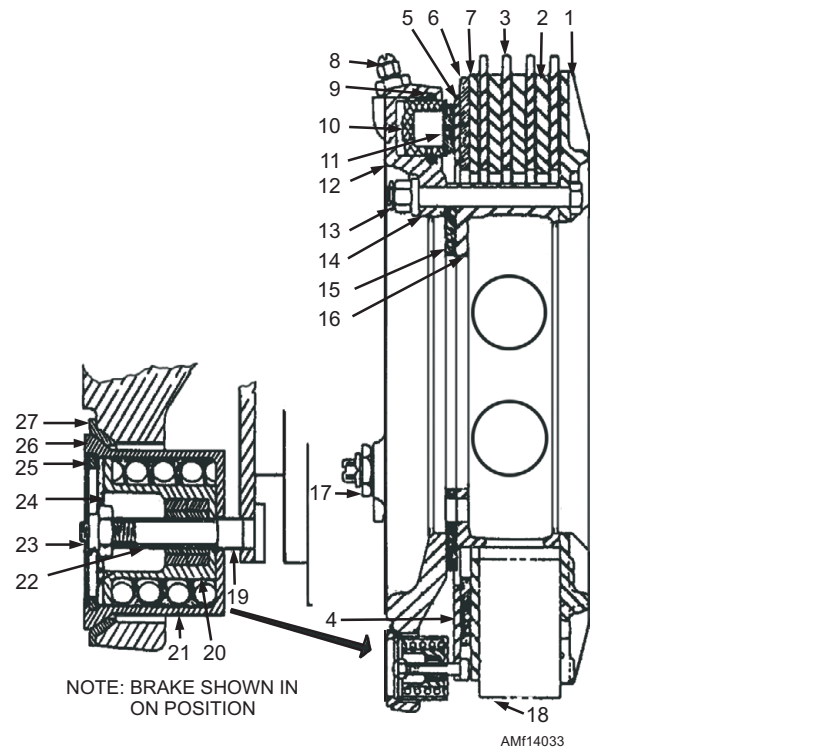

- | | | |
|-------------------------------|-------------------------------|-----------------------------|
| 1. Housing backplate | 10. Piston | 19. Self-adjusting pin |
| 2. Stationary discs | 11. Piston insulator | 20. Return-spring guide |
| 3. Rotating discs | 12. Brake housing subassembly | 21. Return spring |
| 4. Pressure plate subassembly | 13. Self-locking nut | 22. Self-adjusting pin tube |
| 5. Pressure plate | 14. Brake assembling bolt | 23. Self-locking nut |
| 6. Wear plate insulator | 15. Torque tube spacer | 24. Split collar grips |
| 7. Wear plate | 16. Keyed torque tube | 25. Retaining ring |
| 8. Bleeder valve | 17. Inlet bushing | 26. Spring housing |
| 9. O-ring and backup ring | 18. Self-adjusting mechanism | 27. Spring housing bushing |

Figure 14-33.—Trimetallic brake assembly—cross section.

against the discs and against the housing backplate. As the pressure is applied and the brake starts to actuate, the lateral movement of the pressure plate subassembly pulls the self-adjusting pins, the split collar grip and tube subassemblies, and the return spring guides against the return springs, compressing them until the spring guides bottom in the housings. When the hydraulic pressure is relieved, the return spring mechanisms, acting through the heads of the self-adjusting pins, pull the pressure plate subassembly back to the released position. The pistons also return to their deactuated positions. The extent of the return motion is limited by engagement of the spring guides with the retaining ring stops inside the spring housing.

As the discs wear, self-adjusting pins and tubes are pulled through the split collar grips by the force exerted on the pressure plate by the pistons. This small movement of the adjusting pins and tubes, relative to the grips, is equivalent to the combined wear of all the

discs. When pressure is removed from the brake, the return springs return the pressure plate and the brake pistons to the designed reset clearance and maintain a constant displacement.

Maintenance

Intermediate maintenance of the trimetallic brake assembly consists of disassembly, cleaning and inspection, wear pad replacement as necessary, reassembly, and testing.

DISASSEMBLY.—Place the brake assembly with the brake housing down and remove the brake housing bolts. Remove the backing plate and all discs from the torque tube, and then remove the torque tube. Turn the brake over and remove the self-locking nuts to release the return pins. Remove the tube and grip assemblies, pressure plate, and the remaining return spring parts. The tube and grip assemblies should not be disassembled. If they require replacement, replace the complete assembly as a unit.

The piston insulator is removed from the pistons, and the pistons are removed from the brake housing by threading a return pin into the threaded hole in the piston and pulling slowly. Exercise care to avoid damage to the seal groove and cylinder walls. Remove the bleed valve assembly and the brake inlet plug assembly.

CLEANING AND INSPECTION.—Dust and loose grit are removed by using low-pressure air, and then all parts are cleaned in a P-D-680 cleaning solvent and dried with a clean, lint-free cloth.

All metal parts are visually inspected for cracks, wear, or other damage, as specified in the “Intermediate Repair” section of the MIM. Some parts may require inspection by one of the nondestructive methods. The return spring is inspected for proper resilience. The amount of force required to move the grips on each tube and grip assembly is checked with a special tube and grip tester.

The rotating disc is inspected for cracks, distortion, and thickness. The disc must be replaced if it is worn below 0.2-inch thickness, if it is cracked, or if the friction mix is worn unevenly. The friction mix may be pitted up to 0.5 square inch in any segment.

The stationary disc is inspected for cracks and thickness. If the minimum thickness is less than 0.3 inch or the disc is cracked, it should be replaced.

The backplate and pressure plate should be replaced if they are cracked. If the wear pads are worn to less than 0.088-inch thickness, they should be replaced.

WEAR PAD REPLACEMENT.—Wear pad replacement on the pressure plate and the backing plate is authorized. Drill out rivets that hold the worn pads. Discard the worn pads. Check the plates for cracks, deformation, and rivet hole elongation. Use a standard squeeze rivet machine to rivet the replacement wear pads to the plates, using the type of rivet specified in the applicable MIM. The rivet bucktail must be below the surface of the wear pad. Rivets with more than one crack visible in the bucktail or with less than 50 percent of the circumference of the formed head flush with the sides of the countersunk area are not acceptable. The new wear pads must be surface ground to 0.100-inch thickness, and should be flat within 0.010 inch after grinding. The reworked plates should be vapor degreased to remove all oil and grinding material. The dried plates should be wrapped in clean, heavy paper for protection until they are replaced in the brake assembly.

REASSEMBLY.—Reassembly of the trimetallic brake is essentially in the reverse order of disassembly. Lubricate the packings, retainers, cylinder walls, and other contacting surfaces within the brake housing with a light coating of MIL-G-81322, general-purpose aircraft grease before reassembly. Apply MIL-G-6032B grease to the piston side of the piston insulators. Lubricate the brake housing bolts and the contacting surfaces of the bolt heads with antiseize compound. The coating of these bolts and the contacting surface of the bolt heads, followed by torquing, are referred to in some MIMs as “Lubtork.”

TESTING.—The reassembled trimetallic brake must be tested to ensure the quality of maintenance. Connect the brake assembly to a hydraulic test stand and apply 25 psi to the inlet port. Open the bleeder valve until air-free fluid flows from the valve. Increase the pressure to 1,000 psi for 2 minutes and check for leaks. Relieve and reapply 1,000 psi several times, and then release the pressure slowly to 90 psi. Holding the 90-psi pressure, measure the clearance between the pressure plate and the first rotating disc. Minimum clearance must be 0.065 inch. If used discs were reinstalled, check for proper rotation. Secure the test stand, disconnect the brake, and plug the inlet port to prevent contamination.

Q14-31. During single or dual brake assembly maintenance, what prevents the piston from returning to its original position when the brakes are released?

Q14-32. What fastness the wheel brake disc guide linings to the disc guide?

Q14-33. How long should you hold the brake pressure when testing for fluid leakage and proper operation on the dual disc brake assembly?

Q14-34. As brake disc wear occurs, what components provide automatic adjustment through the split collar?

Q14-35. What is the minimum percentage of the circumference allowed on rivets used on the wear pad of the formed head flush with the sides of the countersunk area?

SKID CONTROL SYSTEM MAINTENANCE

LEARNING OBJECTIVE: Recognize the organizational- and intermediate-level

maintenance requirements for the proper operation of the skid control system.

An antiskid test set is available for personnel in the AE rating to use on the antiskid system. The operational test normally requires a joint effort on the part of both AM and AE rated personnel.

Organizational maintenance on the antiskid control valve, shown in figure 14-34, is limited to removal and replacement. Intermediate level repair of the valve consists of cure-date seal and parts replacement in accordance with the procedures provided in the "Intermediate Maintenance" section of the MIM. Following repair, the valve must be tested

to verify proper operation both hydraulically and electrically.

Trouble analysis/troubleshooting of the antiskid system is generally accomplished by personnel of the AE rating. The steps provided for using the antiskid test set will pinpoint the causes for most malfunctions. Those steps that do not meet the specified results are investigated, parts are replaced as necessary, and the complete operational check is repeated to verify that the malfunction has been corrected.

Q14-36. What rating is generally responsible for troubleshooting and trouble analysis of the antiskid system?

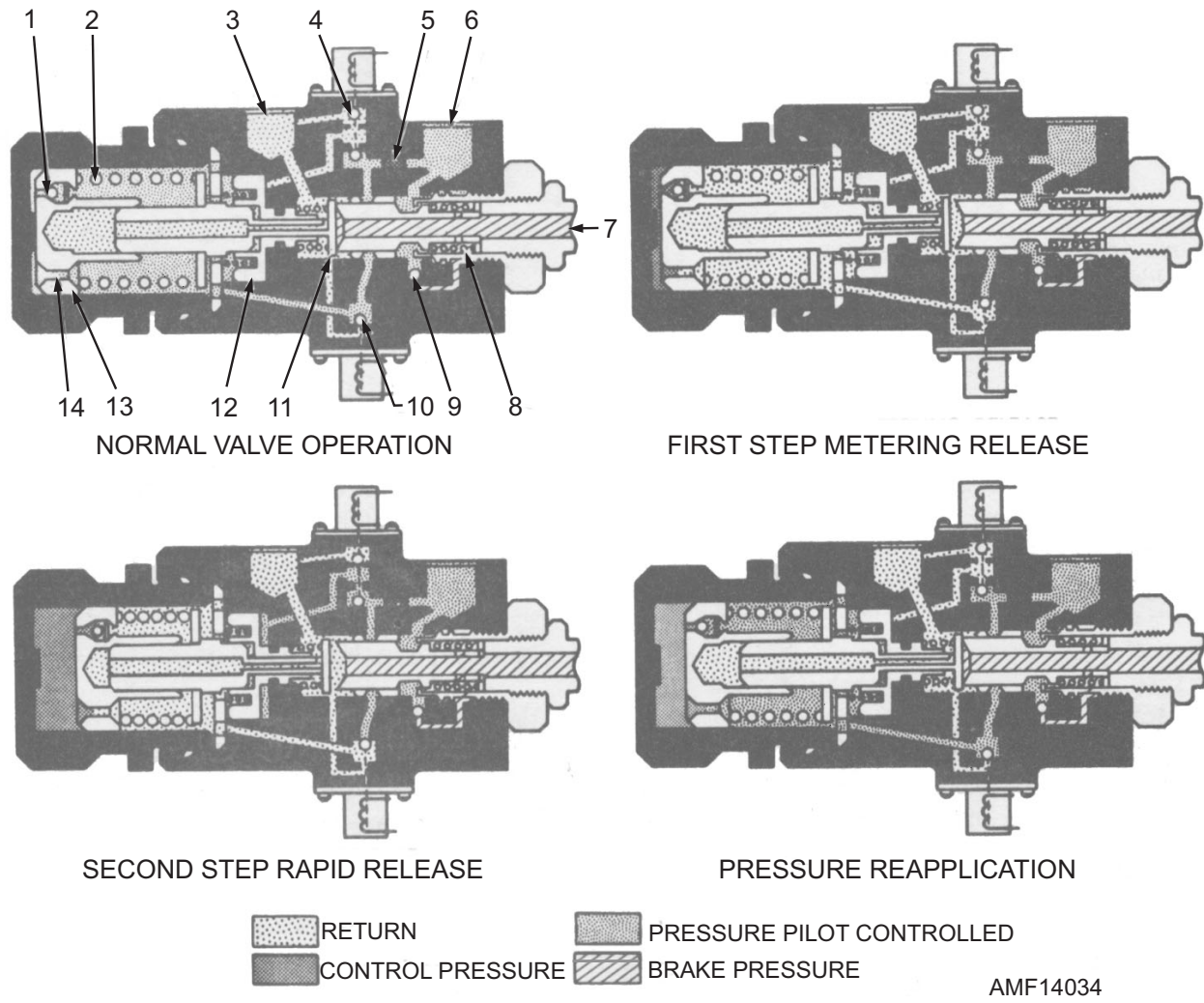

- | | |
|-------------------------------------|-------------------------------------|
| 1. Control orifice No. 2 (release) | 8. Poppet |
| 2. Control spring | 9. Ball check |
| 3. Return | 10. First step solenoid pilot valve |
| 4. Second step solenoid pilot valve | 11. Return seat |
| 5. Filter | 12. Release piston |
| 6. Pressure | 13. Control piston |
| 7. Brake | 14. Control orifice No. 1 |

AMF14034

Figure 14-34.—Antiskid control valve schematic.

CHAPTER 15

UTILITY HYDRAULIC SYSTEMS

INTRODUCTION

These systems may be powered by the aircraft power or aircraft utility hydraulic systems. Some units receive power throughout the flight, while others are isolated from system pressure to prevent unnecessary loss of hydraulic fluid caused by damage or system malfunction.

The systems discussed here are representative of systems that you may be required to work on. Values, such as tolerances, pressures, and temperatures, are given to provide detail in the coverage. You should bear in mind that changes in these values are sometimes necessary because of experience and data gathered from fleet use. When actually performing the maintenance procedures discussed, you should consult the current applicable technical publications for the latest information and exact values to be used.

NOSEWHEEL STEERING SYSTEMS

LEARNING OBJECTIVE: Identify the types of nosewheel steering systems and their components. Identify the applicable maintenance requirements for these systems.

Nose steering systems are hydraulically actuated and can be either electrically or mechanically controlled. The steering actuator serves the dual function of providing steering and dampening (when steering is not engaged).

ELECTRICALLY CONTROLLED NOSE STEERING SYSTEM

This type of nose steering system is an electrically controlled, hydraulically actuated system that provides power steering. When not engaged the system provides automatic nose gear shimmy dampening.

The nose gear is steered by an electrically controlled, hydraulic powered steering cylinder, which is mounted on the nose gear recoil strut. The cylinder is connected through mechanical linkage to an eccentrically mounted drive stud on the recoil strut inner cylinder.

MECHANICALLY CONTROLLED NOSE STEERING SYSTEM

This nose steering system is mechanically controlled and hydraulically actuated in much the same manner as an electrically controlled nose steering system. The steering actuator is of a different design but serves the same dual function of providing steering and dampening, when steering is not engaged.

NOSEWHEEL STEERING SYSTEM COMPONENTS

The nosewheel steering system provides directional control of the aircraft during ground operation in two modes of operation. These modes are nosewheel steering and shimmy dampening.

Operation

Steering on the typical aircraft is accomplished by swiveling the lower portion of the nosewheel shock strut. A rotary-vane type of hydraulic steering unit is mounted on the fixed portion of the shock strut, and is linked to the swiveling portion to which the nosewheel, or wheels, are attached. The nosewheel steering power unit, shown in figure 15-1, uses gears. The steering range varies with each aircraft. For specific degrees of steering range for a particular model of aircraft, you must consult the applicable MIM. For turns requiring a greater steering angle, the pilot can use differential braking, in which case the steering unit is automatically disengaged and the nosewheel, or wheels, swivel freely.

A typical hydraulic steering unit (fig. 15-2) has built-in valves and a follow-up system, and automatically reverts to the shimmy damper mode when not being used as a steering actuator. The valve varies with the type of aircraft. One method is by means of mechanical linkage tied directly to the rudder pedals. Gearing, through a camming arrangement, gives the necessary sensitivity range; permitting satisfactory maneuvering of the aircraft through all speed ranges and turn rates.

Methods of arming or activating the steering systems of the various aircraft used in naval aviation are numerous, and for convenience, a typical aircraft that

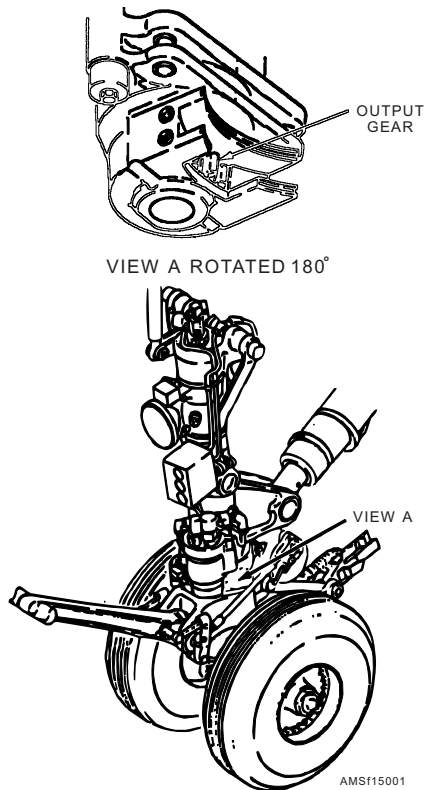

Figure 15-1.—Nosewheel steering power unit.

has capabilities for both land- and carrier-based operations are discussed.

During land-based operation, steering is armed or activated by the pilot. During shipboard operations, the steering system is armed or activated automatically by a switch actuated by the arresting hook when it is extended. Both switches work in conjunction with a weight-on-wheels proximity switch (scissor switch) located on one of the main landing gears. When the strut is compressed a certain amount, the scissor switch completes the electrical circuit to activate the nosewheel steering. Nosewheel steering is desired for carrier landing operations to prevent the nosewheel, or wheels, from swiveling during rollback after arrestment.

Hydraulic Components

The main hydraulic components of the nosewheel steering system are the nosewheel steering power unit and selector valve. See figure 15-2.

NOSEWHEEL STEERING POWER UNIT.—

The nosewheel steering power unit incorporates a rotary, vane-type motor that is powered hydraulically and is electrically controlled through various system

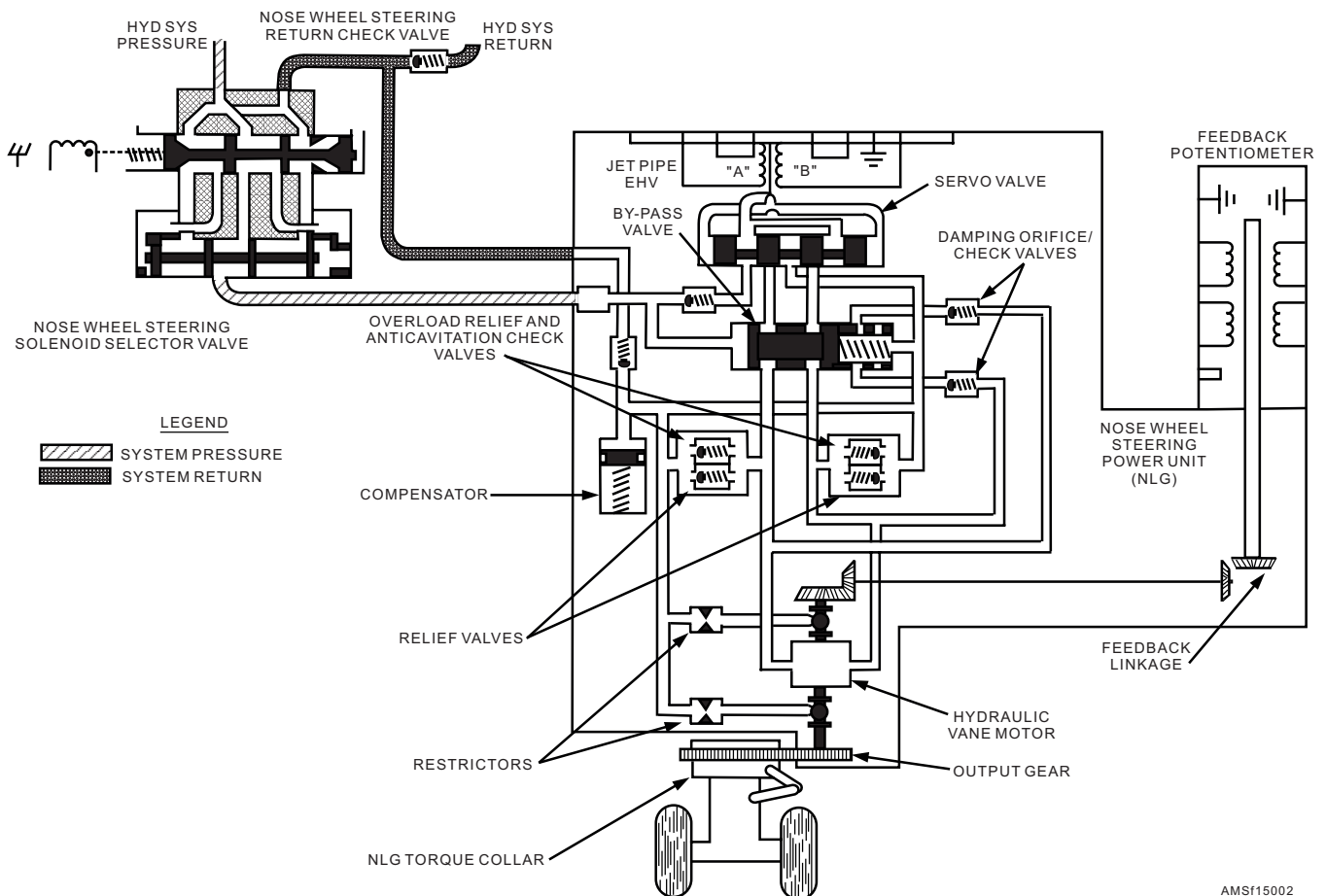

Figure 15-2.—Nosewheel steering system schematic.

components to provide the nosewheel steering function. When not in the steering mode of operation, the nosewheel steering power unit serves as a nosewheel shimmy damper.

The nosewheel steering power unit is mounted to the nose landing gear cylinder, and the output drive gear is meshed with the ring gear of the nose landing gear torque collar. The torque collar deflects the nosewheel as selected by rudder pedal positioning. Hydraulic fluid displaced by the rotating vane during the steering mode is directed back to the hydraulic return system.

When in the damping mode, fluid displaced by a rotating vane is directed through an orifice restrictor inside the nosewheel steering power unit to the opposite side of the vane to provide the dampening feature.

NOSEWHEEL STEERING SOLENOID SELECTOR VALVE.—The nosewheel steering solenoid selector valve is an electrically controlled and hydraulically operated valve. The valve provides pressure and return fluid porting during the steering mode of operation.

Electrical Components

Nosewheel steering electrical components vary greatly. The system uses three basic components. These components are the feedback potentiometer, the command potentiometer, and the steering amplifier.

FEEDBACK POTENTIOMETER.—The feedback potentiometer is mounted to the nosewheel steering power unit, and is mechanically linked or

geared to the vane motor shaft. See figure 15-2. During the steering mode of operation, vane motor rotation drives the feedback potentiometer. When driven, the position transmitter provides a feedback signal to the steering amplifier that is proportional to the amount of vane motor rotation.

COMMAND POTENTIOMETER.—The command potentiometer is attached to the rudder pedal linkage. When the rudder pedals are moved, the command potentiometer generates an electrical signal proportional to the amount of rudder pedal deflection.

STEERING AMPLIFIER.—The steering amplifier sums the signals received from the feedback potentiometer and the command potentiometer. This summation is converted to a modulating signal that is directed to the nosewheel steering power unit's servo valve for nosewheel steering response. With the signals from the command and feedback potentiometer balanced, the servo is returned to a neutral condition, and the nosewheel steering power unit stops at the selected position.

ELECTRICALLY CONTROLLED NOSE STEERING SYSTEM MAINTENANCE

Maintenance of an electrically controlled nose gear steering system consists of operational checks, troubleshooting, system bleeding, and parts adjustment. These maintenance functions normally require a joint effort on the part of the AM and the AE personnel. See figure 15-3.

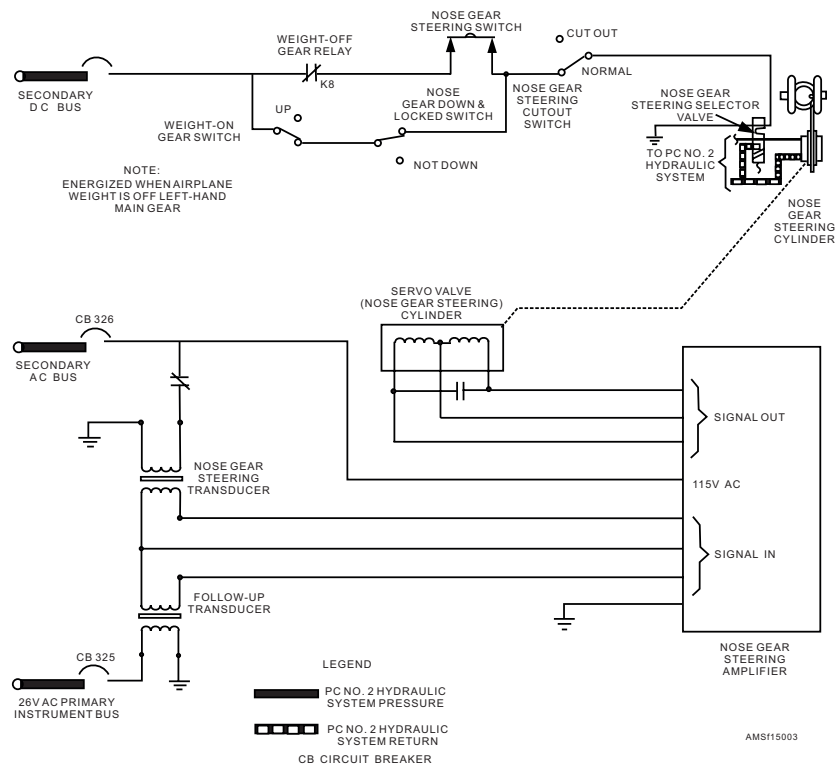

Figure 15-3.—Nose gear steering system diagram.

Operational Check

Perform an operational check to make sure the quality of corrective or preventive maintenance is as expected. Use the following procedures:

1. Jack the aircraft.
2. Connect electrical power and external hydraulic power to the hydraulic system.
3. Manually turn the nose gear to about 30 degrees to the right of center.
4. Operate the nose gear steering switch, and check to see that nose gear steering does not engage.
5. Be sure that personnel and equipment are clear of the arresting hook. Extend the arresting gear and check to see that the nose gear returns to center.
6. Simulate "weight on wheels" by depressing the switch in the left wheel well. Engage the nose gear steering and partially depress the right rudder pedal. Check to see that the nose gear makes a partial right turn and stops.
7. Return the rudder pedals to neutral, and check to see that the nose gear returns to within 0.15 inch of the center.
8. Release the steering switch, and check to see that the nose gear stays in the center position.
9. Retract the arresting gear, and repeat steps 6 and 7. Move the rudder pedal partially left.
10. Operate the steering switch, and slowly press the right rudder pedal for a full right turn. The triangular mark on the top front of the housing must be within ± 0.2 inch of the right 61-degree mark on the steering cap. Repeat this process with the left rudder pedal.
11. Manually turn the nose gear left, and then right to 0.3 inch beyond the 61-degree index mark on the steering cap. With the steering switch actuated, the system must be inoperative (beyond steering limits).
12. With the rudder pedals in the clean configuration, move the nose gear left. Then move the nose gear right to within 0.4 inch of the 61-degree limit, and operate the steering switch. The gear should return to neutral.
13. Release the weight-on-wheels switch and check to see that the nose gear steering disengages.
14. Release the steering switch, and disconnect external electrical and hydraulic power.

15. Lower the aircraft and remove jacks.

16. Close access doors and check cockpit and nose gear well for cleanliness and loose gear.

Troubleshooting

You can accomplish troubleshooting by studying system diagrams and related troubleshooting analysis charts. Malfunctions shown in the troubleshooting tables are in numerical order. The numbers relate to corresponding number(s) following the steps of the operational check. If trouble symptoms are known, you can accomplish troubleshooting without reference to the operational check. However, following system repair, perform an operational check to verify proper system operation.

Bleeding the System

Bleed the system every time you replace a part or disconnect a line. Clear the nose gear from the deck with the hydraulic and electrical power connected. Depress the nose gear steering switch and operate the rudder pedals. As the nose gear steering cylinder moves, open and close the extend and retract bleed ports. Do the same with the relief valve bleed port at the steering cylinder until the hydraulic fluid is free of air. Cycle the steering system five complete cycles. Secure the bleed ports and lockwire. Disconnect electrical and hydraulic power and remove the jack.

Adjustment of Components

Connect external hydraulic and electrical power to the aircraft before adjusting the steering cylinder or amplifier. Jack the nose gear clear of the deck. Adjust the steering cylinder in the following sequence:

1. Center nose gear.
2. Disconnect cylinder rod end from the steering linkage bell crank.
3. Manually extend piston and position gauge set on rod with gauge flush with rod end. Secure gauge to rod end and push flush with cylinder housing.
4. Check to see that the piston rod end will connect to the steering linkage bell crank with gear centered. Adjust the rod end as required.
5. Remove gauge set and attach piston rod end to steering linkage bell crank.

To adjust the steering amplifier, proceed as follows:

1. Insert rigging pin No. 1 in rudder pedal linkage, and check to see that rudder is in neutral.
2. Operate the steering switch and check to see that gear centers within 2 degrees of center index mark.
3. If gear does not center within limits, adjust the steering amplifier potentiometer R7 so that the circuit balances.
4. Remove rigging pin and check the area for foreign objects.
5. Remove the jack and external power.

NOTE: AE personnel normally accomplish the electrical adjustments.

MECHANICALLY CONTROLLED NOSE STEERING SYSTEM MAINTENANCE

Maintenance of mechanically controlled nose steering systems closely parallels the maintenance of electrically controlled nose steering systems. Mechanically controlled nose steering system maintenance consists of the rigging and steering assembly maintenance. See figure 15-4.

Rigging

Rigging of the control linkages consists of several steps. You must jack the nose of the aircraft and operate the rudder pedals to deplete hydraulic pressure. Center the recoil strut manually so that the link arm is in line with the centers of the strut and the steering assembly. Adjust all lower links to move freely overcenter, to make sure that parts are free from binding, and then lock in place with the stops. Install rigging pins in the rudder pedal to nose steering assembly linkages. Adjust the rods to accommodate the installation of the pins. Following adjustment of the linkage, remove the rigging pins and check the system for proper operation.

Steering Assembly Maintenance

O-rings, packings, and miscellaneous parts within the steering assembly can be replaced at the intermediate level of maintenance. Trouble analysis charts are in many of the MIM and O3 manuals. The charts accommodate the systematic checkout of individual components. Like the aircraft troubleshooting charts, they are based on manufacturer's experience, past part discrepancies, and part design.

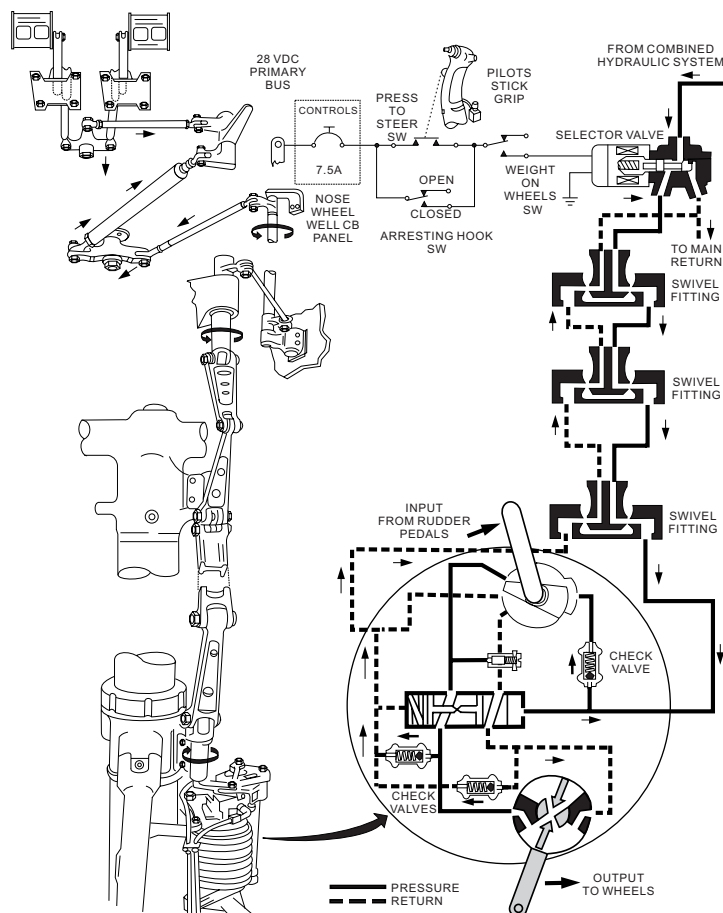

Figure 15-4.—Nosewheel steering system.

AMS115004

They list many of the possible troubles, probable causes, and recommend a commonsense remedy.

Accomplish the disassembly of the steering dampener assembly in the order of the key index numbers assigned to the exploded view illustration in the "Intermediate Repair Section" of the MIM. Before reassembly, clean all parts with a suitable solvent. Air dry with warm, dry, low-pressure (10 psi) air. Nylon, rubber, and Teflon® parts are replaced and not cleaned. You should use the inspection standards in the MIM or applicable 03 manual to inspect all parts of the steering assembly.

Reassembly is essentially a reversal of the disassembly order with appropriate quality assurance checks at specific steps. Following complete reassembly, the steering assembly must undergo the following bench tests:

1. Proof pressure test
2. Input torque test
3. Steering resolution test (input motion versus output motion)
4. Stall leakage test (output shaft in neutral and input shaft fully engaged, and then measure leakage)
5. No steer test (steering assembly in neutral, and then measure leakage at return)
6. External leakage test
7. Static friction torque test (clockwise and counterclockwise torque required to start movement of the output shaft in the power ON and power OFF conditions)
8. Output torque test
9. Steady dampening rate test

The numerous steps involved in bench testing components, such as the steering assembly and the variations between it and other steering actuators, make it impractical to cover the individual steps in detail. Shop and quality assurance personnel must ensure that each component repaired at the intermediate maintenance level is actually in a ready-for-issue condition. This requires vigilance on the part of all personnel. A complete bench test must be made according to the test arrangements provided in the MIM or the applicable 03 manual.

Q15-1. When the electrically controlled nose steering system is NOT engaged, what benefit does it provide?

Q15-2. The nosewheel steering system provides directional control of the aircraft during ground operations in how many modes of operation?

Q15-3. How is the nosewheel steering system armed or activated during shipboard operations?

Q15-4. What type of motor is incorporated in the nosewheel steering power unit?

Q15-5. What are the three basic electrical components used in the nosewheel steering system?

Q15-6. The signals from the command and feedback potentiometers have to be in what condition for the nosewheel steering power unit's servo valve to return to a neutral condition?

Q15-7. Maintenance functions on electrically controlled nose gear steering systems are normally performed by which two aviation ratings?

ARRESTING GEAR SYSTEM

LEARNING OBJECTIVE: Recognize the types of arresting gear systems. Identify their components, and the applicable maintenance requirements.

The arresting gear system controls operation of the arresting hook and the supplementary equipment required to lower and raise the hook for carrier operation. At organizational maintenance levels, maintenance of the arresting gear system consists of servicing the snubber-actuator and bumper assemblies, operational checks, troubleshooting, rigging and adjusting the system, and removal and installation of components within the system.

WARNING

Before operating the arresting gear, make sure all personnel and equipment are clear of the area through which the gear moves. When checking arresting gear operation, always provide suitable protection for the arresting hook point. Place a sandbag or padding on the deck. Failure to observe proper maintenance procedures could result in damage to aircraft and injury to personnel.

ARRESTING HOOK ASSEMBLY INSPECTION

The periodic maintenance information cards for each aircraft and MIM provide detailed information on the inspection, replacement, and disposition of arresting hook assemblies. This information is based on a specified number of arrested landings. The inspection and replacement interval is dependent on the type of hook.

There are currently three types of arresting hooks. Type I integral type arresting hook is highly heat-treated with an uncoated hook point. Type II integral type has a Metco-coated hook point. Type III detachable hook point is heat-treated, stainless steel or alloy, and coated with Colmony or Metco. As an example, the conditional maintenance requirements cards for a representative aircraft with a type II hook assembly requires inspection of the arresting hook stinger and centering block after 10 recorded arrestments. The inspection consists of the following:

1. Checking the hook shank, centering block, and truss members for cracks, misalignment, and obvious damage
2. Checking the stinger (I-beam and hook point) for transverse cracks in the Metco coating, extending to the base metal
3. Chipping or gouging in the cable contact groove
4. Cracks or defective bonding of the Metco coating

Any of these conditions are cause for rejection and replacement of the assembly.

Following inspection or installation of a new arresting gear assembly, apply grease conforming to that recommended by the applicable MRC and/or the MIM to the cable groove area.

Whenever the arresting hook experiences a double wire engagement, strikes the ramp or a deck protrusion, or approaches but does not exceed 100 arrestments, replace designated parts of the complete arresting gear mechanism. The removed parts are forwarded to the designated depot-level maintenance activity for test and overhaul. Include the total number of arrestments on the screening and ready-for-issue tags. This number is necessary so that an accurate account of the total number of arrestments of each assembly can be maintained.

Detachable hook points that are removed for inspection after 10 arrestments are reinstalled or replaced with new attaching hardware (nut, bolt, washer, etc.). Install the bolt with the head down and the nut on top. In all cases, periodic maintenance of the arresting hook assemblies should be in accordance with the applicable MIM and/or maintenance requirements cards.

SINGLE SHANK CENTERING DEVICES

Single shank-type arresting hook assemblies are held in the centerline position for retraction into their fuselage recesses. The centering devices prevent side movement of the assembly during carrier-arrested approaches.

Liquid Spring

The representative arresting gear mechanism, shown in figure 15-5, uses a liquid spring for this

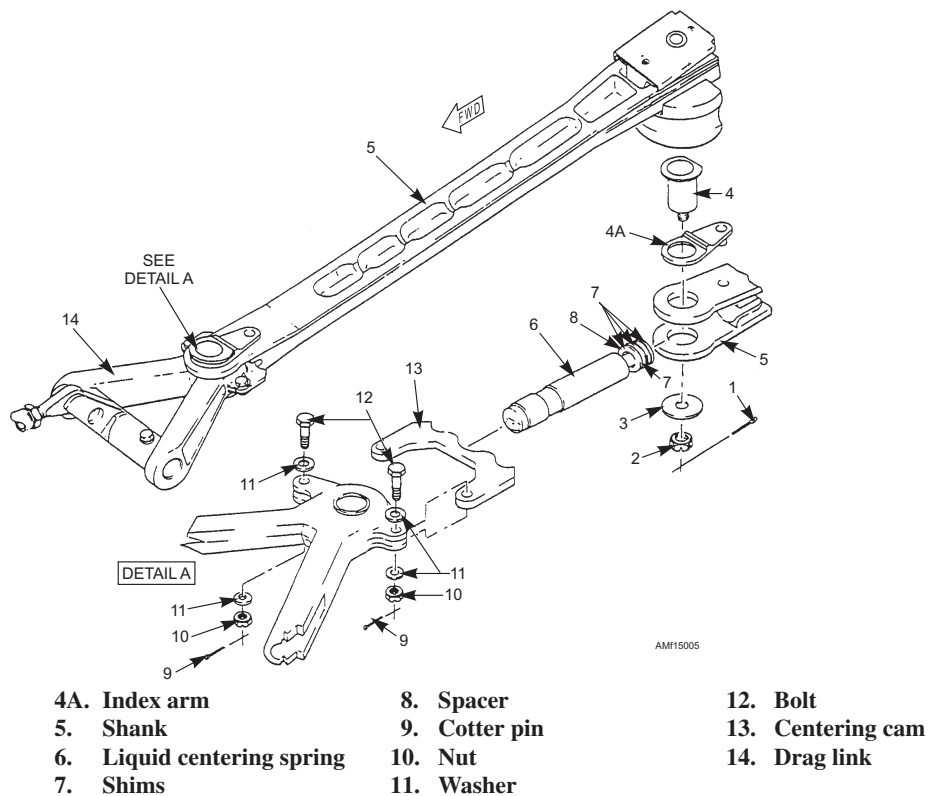

Figure 15-5.—Arresting gear mechanism.

purpose. The spring is located within a recess of the hook shank, and the keyed end presses against the centering cam. On installation, shim the spring until the thickness of the spacer and shims is approximately 0.125 inch. Install the spring in the shank, and then secure the shank to the drag link. Check the hook point for excessive side play. If side play exceeds 0.24 inch, add more shims to the spring. The total thickness of shims must not exceed 0.185 inch. Any time shim thickness exceeds 0.150 inch, move the hook laterally several times in each direction to make sure that the hook can move 40 degrees left and right without bottoming out the liquid spring.

While liquids are normally thought of as incompressible, the action of the liquid spring is based on the slight compressibility of liquids. Figure 15-6 illustrates the disassembled spring assembly. Most of the internal parts are classified as nonrepairable, and damage will require replacement of the parts at the depot level of maintenance.

The spring assembly contains 19 cubic centimeters of oil, MIL-S-21568. The oil is confined within the piston cylinder assembly, and any side movement of the arresting hook shank must be against the compressibility of the oil. The maximum travel or compressibility of the overall liquid spring assembly is 0.68 inch. The operating pressure within the assembly,

when bottomed out, will be as high as 20,000 psi. In the static condition, the oil trapped within the spring assembly is under a return preload pressure of 350 pounds, which is created by the reassembly of the close tolerance parts that confine the liquid.

The tolerances of parts within the liquid spring and the necessity to subject certain parts to approximately -110°F for varying lengths of time during the disassembly and assembly process make it impractical for it to be overhauled at the lower levels of maintenance.

Damper Cylinder

The representative arresting gear assembly employs a vertical damper cylinder and two horizontal dampers to dampen hook motion caused by deck impact forces. See figure 15-7. Two centering spring assemblies maintain the hook in the center position.

With the arresting hook lowered, the centering springs are adjusted in the following manner:

1. Center the hook assembly.
2. Adjust the rod ends of both centering springs to reach the attaching pivot holes. Threads must be visible through the rod end inspection hole. See figure 15-8.

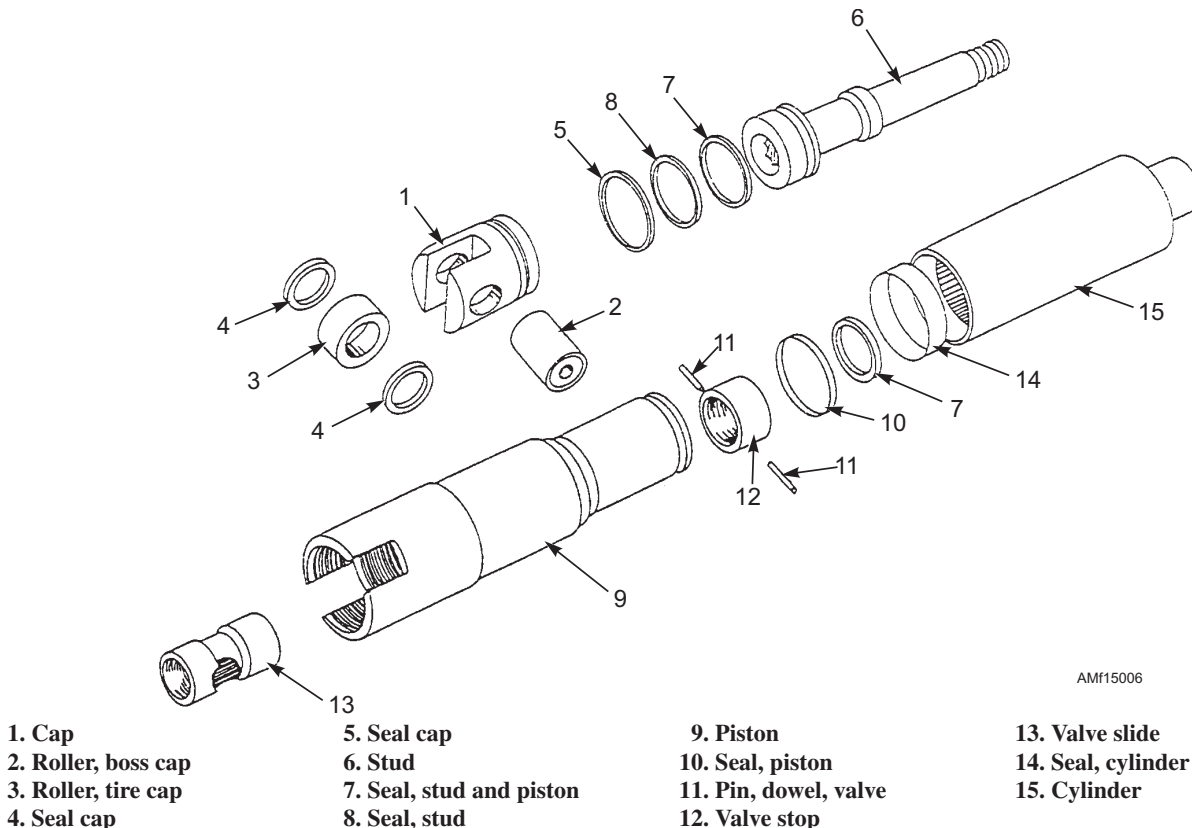

AMf15006

Figure 15-6.—Liquid spring shock assembly.

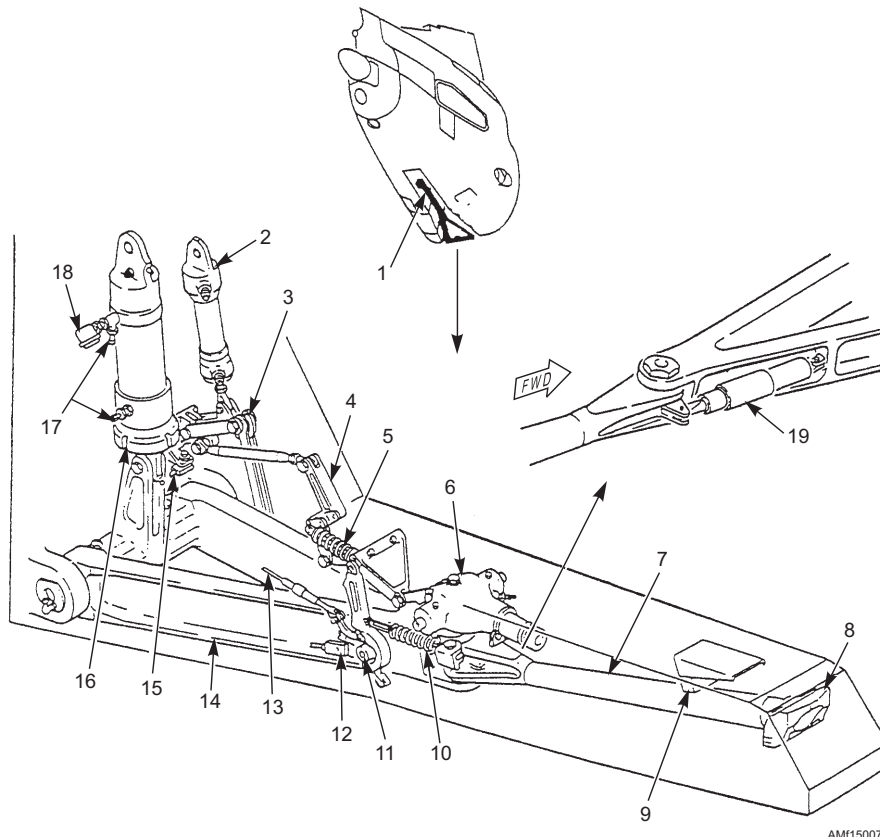

AM115007

- | | | |
|---------------------------------|---------------------------|-----------------------------|
| 1. Arresting hook assembly | 8. Point | 15. Down switch |
| 2. Retract cylinder | 9. Rubber bumper | 16. Shock absorber |
| 3. Mechanical linkage and lever | 10. Uplatch spring | 17. Charging valve |
| 4. Bell crank assembly | 11. Uplock roller bearing | 18. Pressure gauge |
| 5. Bumper actuator | 12. Uplock switch | 19. Liquid centering spring |
| 6. Aft shock absorber | 13. Wire rope | |
| 7. Shank | 14. Drag link | |

Figure 15-7.—Arresting gear assembly.

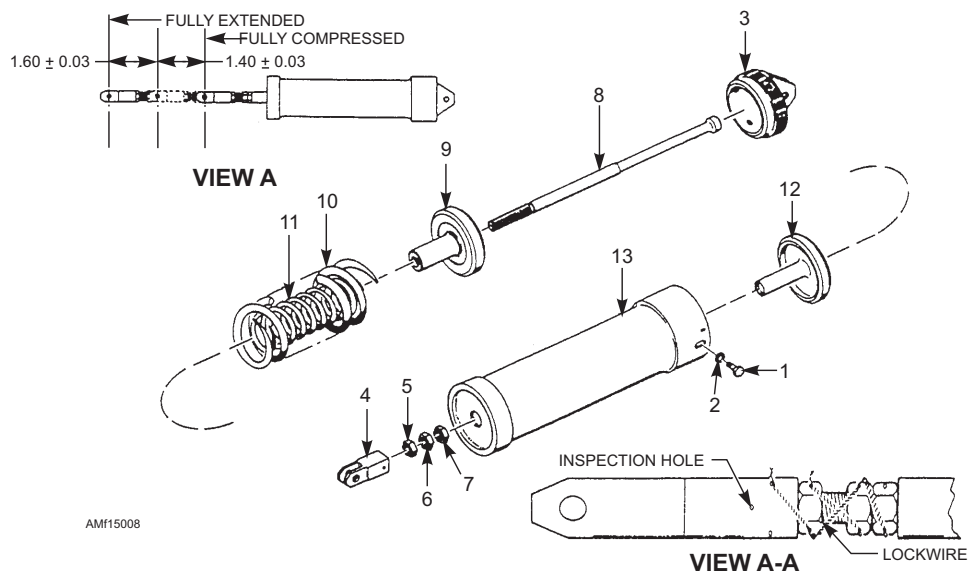

AM115008

- | | | |
|----------------|------------------|------------------|
| 1. Bolt | 6. Jam nut | 11. Inner spring |
| 2. Washer | 7. Check nut | 12. Plunger |
| 3. End fitting | 8. Piston rod | 13. Shell |
| 4. Rod end | 9. Support | |
| 5. Jam nut | 10. Outer spring | |

Figure 15-8.—Centering spring.

3. Tighten the nuts on the attaching bolts fingertight. Safety with cotter pins.

4. Torque the rod end jam nuts to 270-300 inch-pounds and safety with lockwire, as shown in figure 15-8.

5. Check lateral movement of the hook in accordance with the procedures prescribed in the MIM.

Intermediate-level maintenance of the centering springs consists of checking the disassembled parts for scoring, corrosion, nicks, structural deformation, or failure. Nonferrous parts are subjected to fluorescent penetrant inspection and ferrous parts to magnetic particle inspection. The diameter of all parts and the free length dimensions of the two springs, shown in figure 15-8, are checked against the values given in the parts tolerance tables provided in the MIM.

WARNING

Disassembly and assembly require extreme caution. The spring force is in excess of 500 pounds. Failure to observe the proper safety precautions could result in personnel injury.

Post repair testing includes checking the breakout force required to extend and compress the springs. Force required is 560 ± 60 pounds. The spring should extend 1.60 inches ± 0.03 inch and compress 1.40 inches ± 0.03 inch from neutral.

Q15-8. How many different types of arresting hooks are currently used on naval aircraft?

Q15-9. Aircraft with a type II hook assembly installed requires an inspection of the arresting hook stinger and centering block after how many recorded arrestments?

Q15-10. What centering device prevents side movement of the arresting gear mechanism during carrier-arrested approaches?

Q15-11. What prevents arresting hook motion caused by deck impact forces?

Q15-12. Disassembly and assembly of the arresting gear centering spring require extreme caution due to spring forces in excess of how many pounds?

CATAPULT LAUNCH SYSTEM

LEARNING OBJECTIVE: Identify the types of catapult launch systems. Identify their components and applicable maintenance requirements.

The purpose of the nose landing gear catapult launch system is to provide a means of directing the aircraft into position for catapult launching, as well as being connected automatically to the ship's catapult equipment. Such a device eliminates the necessity for flight deck personnel to manually connect catapult harnesses. The system consists of a catapult launch bar, a launch bar actuating cylinder and gimbal, selector valve, leaf retracting springs, and a catapult tension bar socket. See figure 15-9.

The launch bar is swivel mounted on the forward side of the nose gear outer cylinder and may be

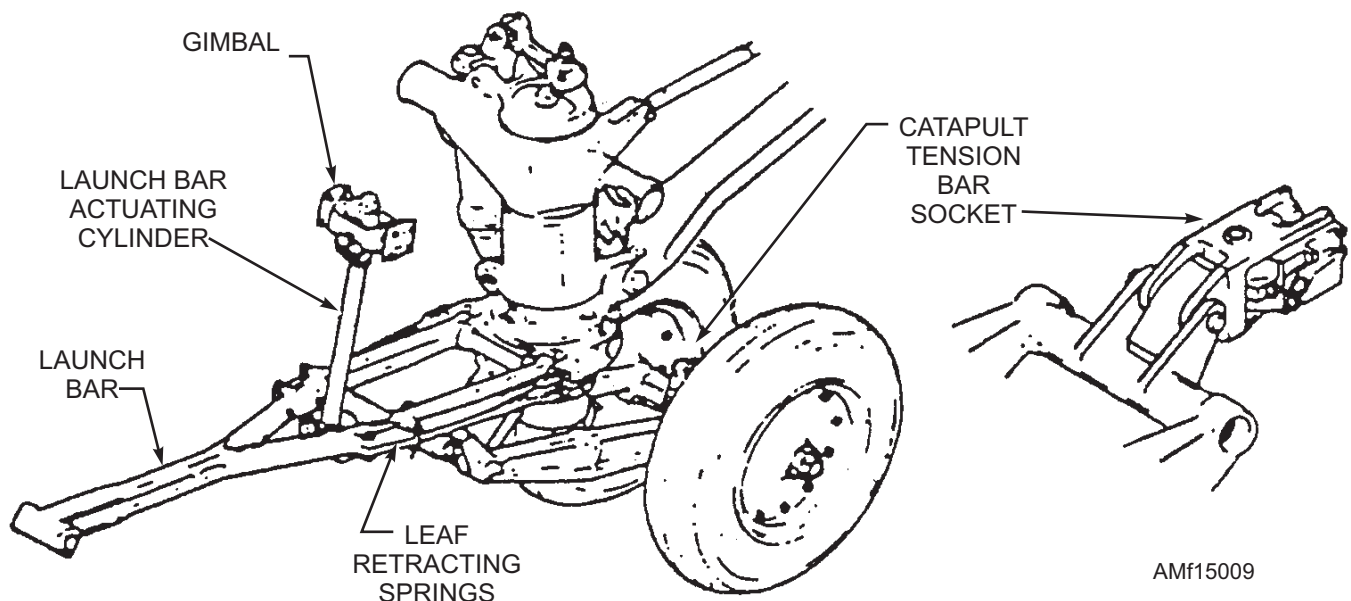

Figure 15-9.—Catapult system.

extended and retracted during taxiing. The launch bar is automatically retracted after catapulting. A launch bar warning light on the main instrument panel comes on any time the following conditions exist:

- The launch bar control switch is in EXTEND.
- The selector valve is in bar extended position.
- The launch bar is not up and locked with weight off the landing gear.
- The launch bar control switch is in RETRACT and the launch bar actuator is not up and locked.

Accessories for the catapulting system include a tension bar and a catapult holdback bar. The catapult tension bar socket is mounted on the nose gear axle beam and provides for attachment of the tension bar for tensioning of the airplane prior to catapulting.

The catapult system, shown in figure 15-10, is selected to extend by placing the launch bar control switch in the cockpit to the EXTEND position. With weight on the gear, this action completes an electrical circuit to energize solenoid A of the launch bar selector valve. The energized selector valve directs hydraulic system pressure to the launch bar actuating cylinder extend port. Hydraulic pressure unlocks locking fingers in the launch bar actuating cylinder and extends the actuator rod end. The actuator rod end is attached to the launch bar, and as the actuator extends, it lowers the launch bar. As the launch bar moves down, it encloses two horns on the nose gear axle beam, enabling the launch bar to steer the nose gear.

Before the airplane reaches the catapult, the tension and holdback bars are attached to the tension bar socket. As the airplane approaches the catapult, the launch bar enters a track that permits the bar to steer the nose gear for alignment with the catapult.

The top of the launch bar actuating cylinder is gimbal-mounted to permit rotation in all directions as the launch bar turns and is raised and lowered. As the airplane moves forward, aligned with the catapult, the launch bar automatically engages the catapult shuttle. The shuttle is advanced to tension the airplane on the catapult.

The launch bar switch is placed in OFF, de-energizing the selector valve. When catapult pressure reaches a predetermined value, the tension bar breaks and the airplane is catapulted off the deck.

In the de-energized position, the selector valve connects the launch bar actuator extend and retract ports to the hydraulic return circuit. The launch bar is held in the down position by the catapult shuttle until reaching the end of the launch run, where the bar is released from the shuttle and the weight-on-gear switch is actuated to the weight-off-gear position. When the switch is activated to the weight-off-gear position, a power circuit is completed to energize the retract solenoid of the launch bar selector valve. The energized valve directs hydraulic pressure to retract the launch bar actuating cylinder, automatically retracting and locking the launch bar. Two leaf springs on each side of the launch bar shank raise the launch bar to the retracted position if automatic hydraulic retraction fails. When

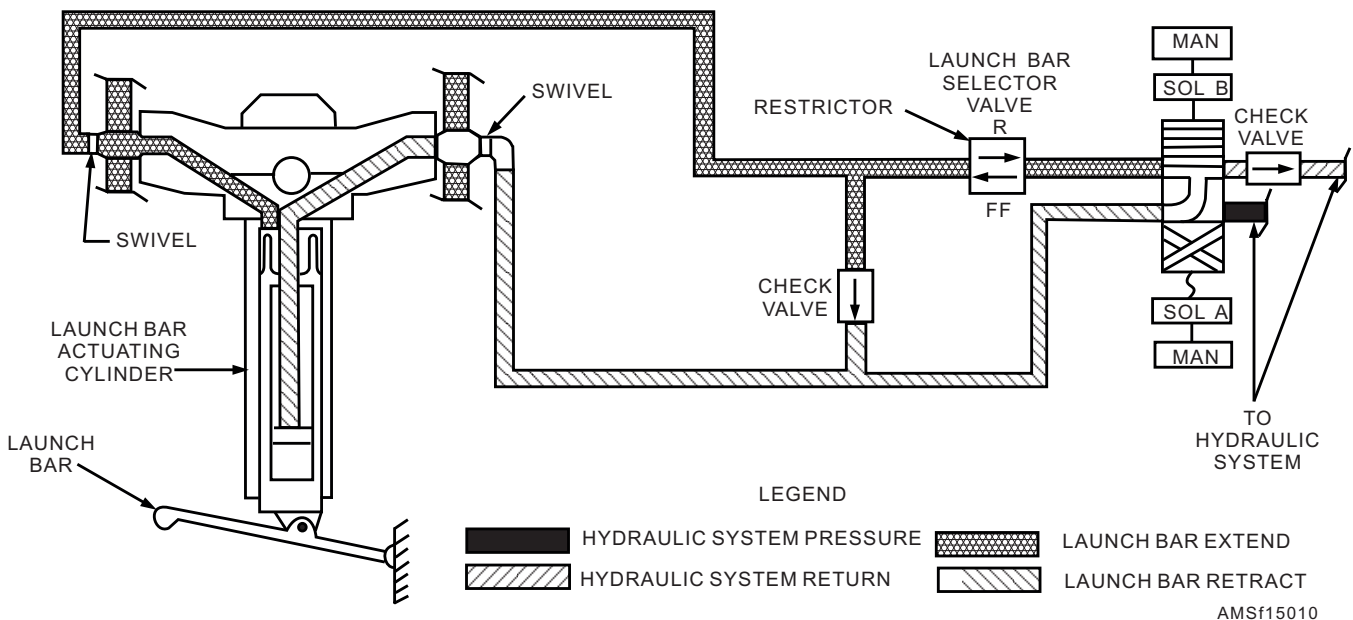

Figure 15-10.—Catapult system hydraulic schematic.

the piston is fully retracted, locking fingers on the piston lock the actuator and launch bar in the retracted position.

Hydraulic retraction of the launch bar is obtained by holding the launch bar control switch in RETRACT. This action completes an electrical circuit to energize the launch bar selector valve retract solenoid (solenoid B). The energized selector valve directs hydraulic pressure to retract the launch bar actuator. The actuator retracts, pulling the launch bar up and locking the actuator and launch bar in the retracted position.

Q15-13. What system eliminates the necessity for flight deck personnel to manually connect an aircraft to the ships catapult harnesses?

Q15-14. What accessories are included for the catapult launching system?

Q15-15. What device on each side of the launch bar shank raises the launch bar to the retracted position if automatic hydraulic retraction fails?

IN-FLIGHT REFUELING SYSTEMS

LEARNING OBJECTIVE: Identify the types of in-flight refueling systems. Identify their components and applicable maintenance requirements.

Air refueling systems permit complete in-flight or on the ground refueling of the aircraft fuel system. The refueling probe extension and retraction system shown

in figure 15-11 consists of the refueling probe, refueling nozzle, a self-locking, two-position probe actuating cylinder, a lock swivel joint, two restrictor valves, a selector valve, and associated electrical switches and relays.

With the engines operating or external electrical and hydraulic power applied, the probe is extended by placing the refueling probe switch in the EXTEND position. This electrically actuates the solenoid selector valve to supply restricted hydraulic flow to the extend port of the probe-actuating cylinder. The restrictor valves control the rate of cylinder extension and retraction. The check valve prevents pressure surges in the hydraulic return system from unlocking the probe-actuating cylinder during flight.

After disengaging the probe nozzle from the tanker drogue, hold the air refueling switch in RETRACT to actuate the solenoid selector valve to supply pressure to the retract port of the probe actuating cylinder, causing it to retract and lock the probe into place. A cockpit advisory panel transit light goes out whenever the probe is locked in the extended or retracted position. A probe floodlight, which illuminates the probe tip for visual contact with the refueling drogue at night, is on whenever the refueling probe switch is in EXTEND and exterior lights are on. The floodlight goes out when the refueling probe switch is placed in RETRACT or OFF. Organizational maintenance of the air refueling probe system normally consists of operational checks, troubleshooting, rigging and adjusting, and removal and installation of components.

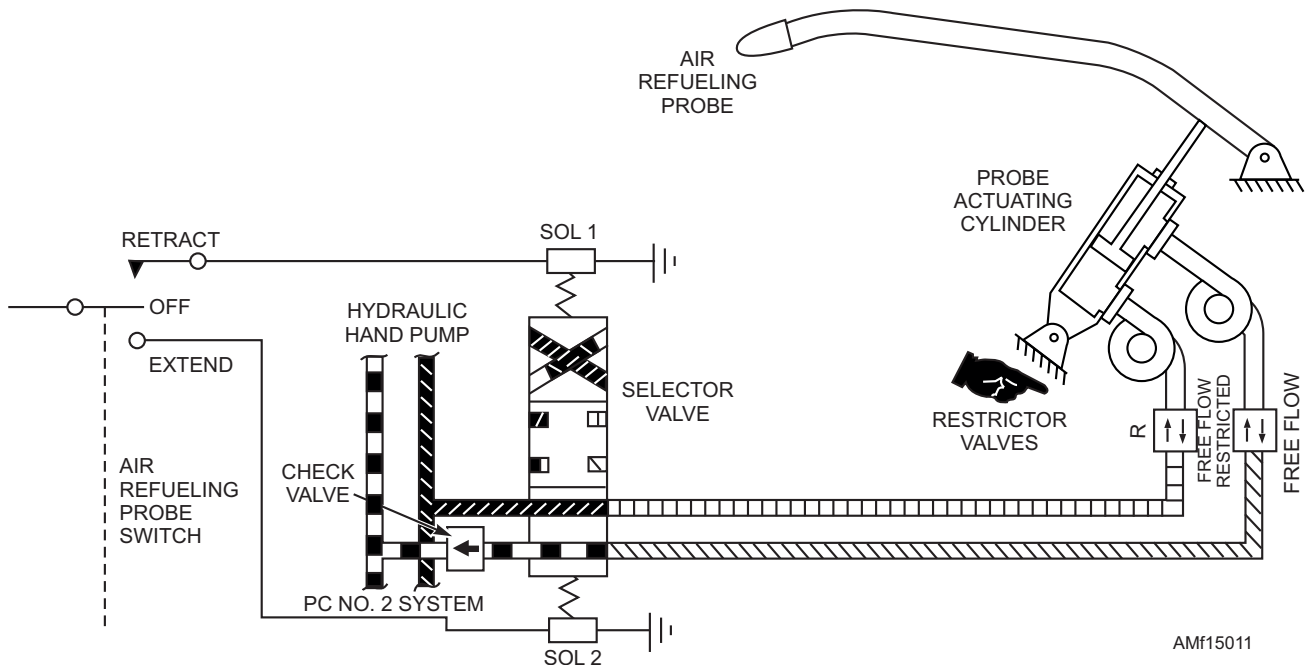

Figure 15-11.—Air refueling probe hydraulic system.

To perform an operational check of the air refueling probe system, the hydraulic system must be pressurized to 3,000 psi, external electrical power applied, and the in-flight refueling circuit breaker engaged. Before actuating the system, ensure that all personnel and equipment are clear of the area of probe travel. The extension cycle rotates the probe from its stored locked position to an extend locked position.

Position the fuel probe switch to EXTEND. Check for proper probe extension and probe locking. If operation of the probe is not smooth, check for air in the system. Position the fuel probe switch to RETRACT and check for proper probe retraction. The complete extension cycle should be from 5 to 7 seconds, with the retraction cycle taking from 9 to 11 seconds.

Troubleshooting of the system should include a thorough knowledge of the malfunction compared to proper system operation and referral to system schematics and troubleshooting tables provided in the MIM. System rigging, component removal and installation, and all other maintenance should be in accordance with the procedures and safety precautions outlined in the MIM.

Intermediate maintenance of faulty components consists of cure-date kit installation and testing in accordance with the "Intermediate Maintenance" section of the MIM or the applicable (03) overhaul manual.

Q15-16. What component in the in-flight refueling system prevents pressure surges in the hydraulic return system from unlocking the probe-actuating cylinder during flight?

Q15-17. Prior to performing an operational check on the in-flight refueling system, what actions must you take?

Q15-18. What should the complete extension and retraction time cycles be when performing an operational check on the in-flight refueling system?

WING FOLD SYSTEMS

LEARNING OBJECTIVES: Identify the types of wing fold systems. Identify their components and applicable maintenance requirements.

There are miscellaneous differences in the design and operating characteristics of the various hydraulically operated systems, and the wing fold systems are no exception. Basically similar components perform similar functions with only minor variation in part nomenclature and physical design.

The wing fold system described in the following paragraphs will point out some of these differences. Refer to the wing fold system schematic shown in figure 15-12 as you read the following paragraphs.

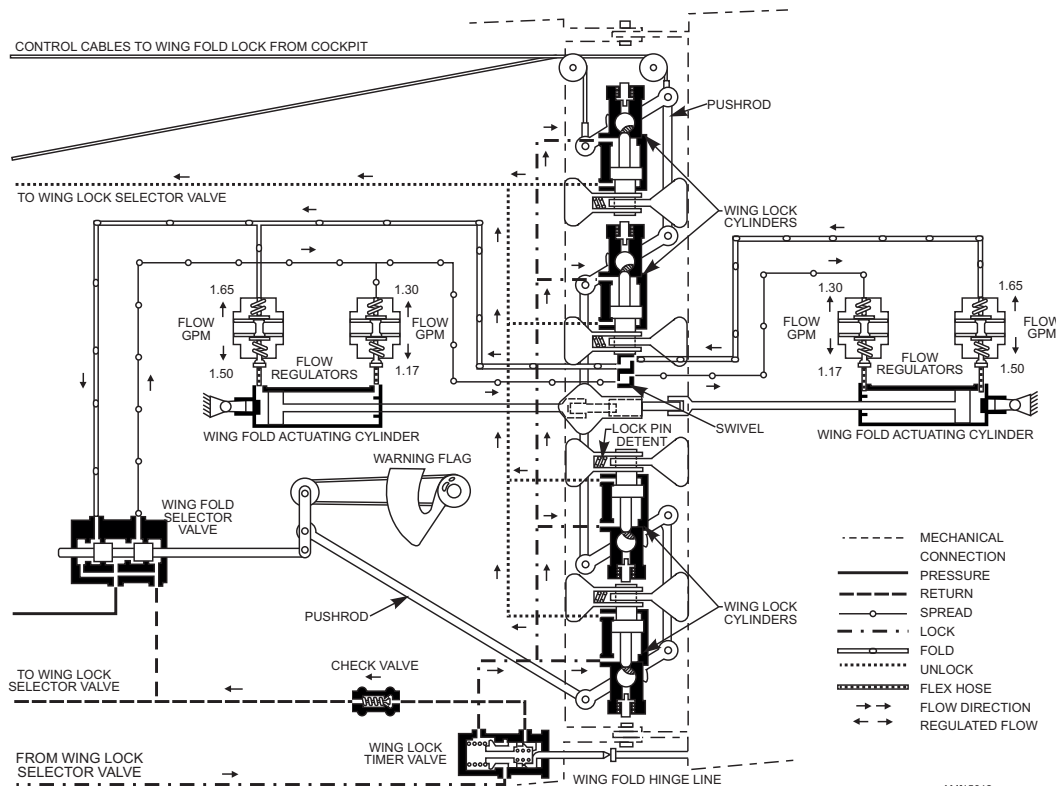

Figure 15-12.—Wing fold schematic (spread and locked condition).

The wings are unlocked by lifting the wing fold handle up and forward until it reaches the first stop. This action operates the cable and pushrod mechanisms that control mechanical locking of the wing lock cylinders. This same action, through the pushrod connected to the mechanical locks, causes the warning flags to appear on top of the wings. Further movement of the wing fold handle at this point is prevented by a spring-loaded mechanical latch that blocks the crank at the wing lock cylinder.

With flight controls in the proper position and weight on the wheels, the wing fold lockpin switch is placed at UNLOCK. Power is supplied to the unlock side of the wing lock selector valve, allowing combined system utility hydraulic pressure to the four wing lock cylinders in each wing. Pressure in the wing lock cylinders moves the lock shaft to retract the wing lockpins. After completion of this action, the wing fold control handle can be moved to the full forward position, operating the wing fold selector valve in each wing and porting hydraulic pressure through flow regulators to the wing fold actuating cylinders, which extend and cause the wing to fold.

The wings are spread by moving the wing fold control handle aft to the first stop, mechanically positioning the wing fold selector valve in each wing to port hydraulic pressure through flow regulators to the wing fold cylinders, causing them to retract and spread the wings. The wing fold control handle is held at the first stop by the retracted lockpins, which prevent rotation of the lock shafts and cranks.

After spreading action, the wing fold lockpin switch is placed at LOCK, and power is supplied to the lock side of the wing lock selector valve. The selector valve then ports hydraulic pressure to the closed timer valve in each wing fold joint. As spreading is completed, a spring-loaded lockpin detent in each inboard wing lock fitting is depressed by the outboard lock fitting. When the lock fittings are aligned, the lockpins can extend and enter the wing lock fittings. With lockpins extended, the lock shaft is free to rotate, and the wing fold control handle can be moved flush with the top surface of the center console. This action rotates the lock shafts to prevent retraction of the lockpins and retracts the warning flags. When any lockpin fails to extend, the wing fold handle cannot be secured, and the warning flags will remain exposed.

A thermal relief valve is installed in the pressure line of the wing fold and wing lock selector valves. It vents excessive pressure buildup because of the thermal expansion of trapped fluid into the combined system

return lines. When pressure increases above 3,730 to 3,830 psi, the spring-loaded ball check unseats, and the valve relieves excessive pressure. The spring-loaded ball check reseats when pressure falls to 3,360 psi.

Maintenance of the wing fold system at the organizational level consists mainly of scheduled inspections, lubrication, rigging of mechanical linkages, removal and installation of components, and analysis of system malfunctions.

The MIM provides system schematics and trouble analysis sheets to assist in pinpointing causes of malfunctions. A thorough knowledge of the system before troubleshooting is necessary. Logical reasoning plus a systematic operational checkout of the system will produce better results than trial and error troubleshooting methods.

Lack of lubrication or other required maintenance at prescribed intervals will generally be reflected by stiff, hard-to-operate wing fold control mechanisms or related wing fold discrepancies. Strict compliance with maintenance requirements, in all cases, will eliminate or minimize this possibility. All corrective maintenance should be in accordance with the instructions provided in the appropriate MIM.

Wing lock warning flags rarely get out of adjustment, and whenever they fail to retract, it should be considered an indication of failure of all locks to properly enter lock fittings. Realignment to provide a wing lock indication without ensuring that the wings are positively locked certainly does not correct the discrepancy and presents an extremely hazardous flight condition.

Good maintenance practices, strict quality assurance by qualified inspectors, and good supervision will ensure safe, timely, and quality corrective maintenance actions.

Intermediate maintenance of wing fold hydraulic components generally consists of installing cure-date repair kits (sealing devices, etc.) and/or replacement of miscellaneous parts available as fleet-type repair kits. Parts in the repair kit are normally easy-to-replace items, which do not require the depth of disassembly and inspection necessary at complete overhaul, and are replaced whenever high time removal of a component is necessary. Information on repair kits for various components is provided in the applicable "Illustrated Parts Breakdown" and, in some cases, the "Intermediate Maintenance" section of the MIM and appropriate (03) overhaul manuals.

Step-by-step procedures for the repair of components are provided in the "Intermediate Maintenance" section of some MIMs and/or O3 manuals. In general, repairs will consist of cleaning, disassembly, inspection, and replacement of failed parts, reassembly, and testing.

Inspection of disassembled components includes checking for visible damage to internal parts, thread damage, condition of plating, wear limitations, spring distortion, specified free length of spring, and corrosion. In some cases, nondestructive inspection of critical parts to detect discontinuities and fatigue cracks is required.

Reassembly will normally be in the reverse order of disassembly and will include proper installation of parts, seals, packings, retainers, torquing, safety wiring, and cotter keying, as applicable. Test of the component following repair will further verify its ability to perform its intended function and will generally consist of proof testing, static leak testing, and operational testing.

Throughout the complete intermediate level repair operation, the components undergoing repair must be subjected to quality assurance verification of specified repair steps as indicated in the applicable MIM or (O3) overhaul manual. It is NOT sufficient to eliminate the progressive quality assurance and verify the operation of the end product.

Stationary test benches used for testing hydraulic components are filled with preservative hydraulic fluid. Repaired components that are not to be installed immediately must be filled with MIL-H-46170 unless otherwise specified. All openings are capped or plugged with approved metal closures. Repaired

components that are to be installed immediately subsequent to bench testing should be drip-drained, capped, and plugged as necessary. Plastic plugs are prohibited because of the possibility of plastic chips entering the component and damaging seals or blocking critical passages.

The man-hours expended in correcting malfunctions are documented on a VIDS/MAF. When a part is removed and is to be processed through the IMA for repairs, an additional VIDS/MAF is initiated with the appropriate information filled in and attached to the component for turn-in. Consult the appropriate manuals for proper documentation of the VIDS/MAF. The job is not considered complete until the necessary paperwork has been completed, screened, and turned in.

Q15-19. What component is installed in the pressure line of the wing fold and wing lock selector valves to vent excessive pressure buildup because of thermal expansion of trapped fluid into the combined system return lines?

Q15-20. Wing lock warning flags rarely get out of adjustment; however, when one fails to retract, what does it indicate?

GENERATOR DRIVE SYSTEM (HYDRAULICALLY OPERATED)

LEARNING OBJECTIVES: Identify the types of generator drive systems. Identify their components and applicable maintenance requirements.

The ac generator drive system shown in figure 15-13 is hydraulically operated by pressure from the hydraulic power system. The AC GEN switch on the

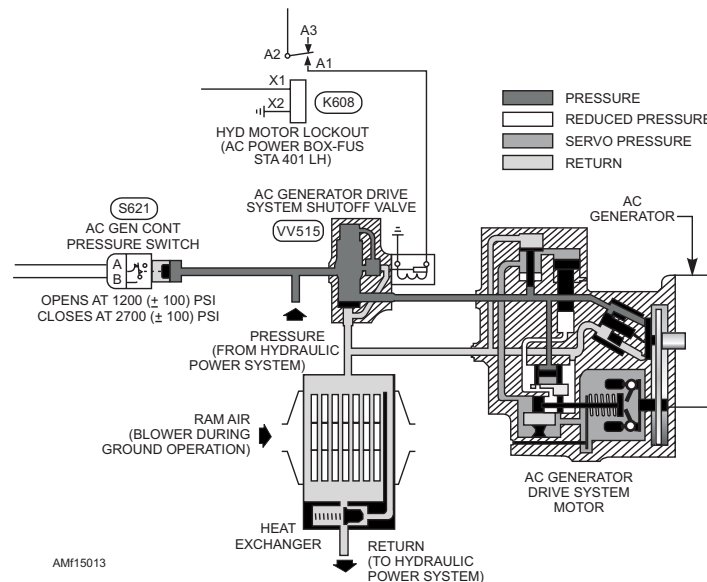

Figure 15-13.—AC generator drive system.

copilot's sub-instrument panel operates the shutoff valve that controls the generator drive system. The system consists of a shutoff valve, a hydraulically driven motor, a heat exchanger, a control switch, and a relay.

During normal aircraft operation and with the AC GEN switch at OFF, the solenoid-operated shutoff valve is energized (closed). The hydraulic motor lockout relay is also energized. Under this condition, the generator does not operate, since hydraulic pressure is stopped at the shutoff valve. When the AC GEN switch is moved to ON, the hydraulic motor lockout relay and the shutoff valve is de-energized and the valve opens. Hydraulic fluid at 3,000 psi is directed to operate the constant speed variable displacement motor at 8,000 rpm. When the fluid exits from the motor into the return lines, it is routed through a heat exchanger and ram air cooled before returning to the power system reservoir. When ram air is not available on the deck, an electrically driven blower is engaged automatically to provide airflow.

Maintenance of the generator drive system normally consists of servicing, testing and checking for proper operation, adjusting, troubleshooting, and removal and installation of system components, flexible line couplings, and other plumbing. Servicing and maintenance procedures and precautions are listed in the MIM and respective (03) overhaul manuals and must be observed at all times to complete the procedures efficiently and safely. Particular attention should be given to cautions and warnings and specified quality assurance considerations.

Q15-21. During normal aircraft operation, the hydraulically operated generator drive system AC GEN switch is OFF, and the solenoid-operated shutoff valve is energized (closed). What other component is also energized?

VARIABLE RAMP AND BELLMOUTH SYSTEMS

LEARNING OBJECTIVES: Recognize the characteristics of the variable ramp and bellmouth systems. Identify their components and applicable maintenance requirements.

The airflow velocities encountered in the higher speed ranges of aircraft are much higher than the engine can efficiently use. Therefore, the air velocity must be controlled for acceptable engine performance.

The variable inlet ramp system positions the inlet ramp (located in the air inlet) so that it will position the shock wave to decrease the inlet air velocity to a subsonic flow with maximum pressure energy. The system also provides for the reflection and bypass of surplus air not required by the engine with a minimum of drag. The inlet system in combination with the bypass bellmouth system allows the inlet duct to take aboard the maximum free airstream. The air not required by the engine is bypassed by the action of the bellmouth ring.

Figure 15-14 shows the ramp sections and associated hydraulic mechanism and linkage. The aft

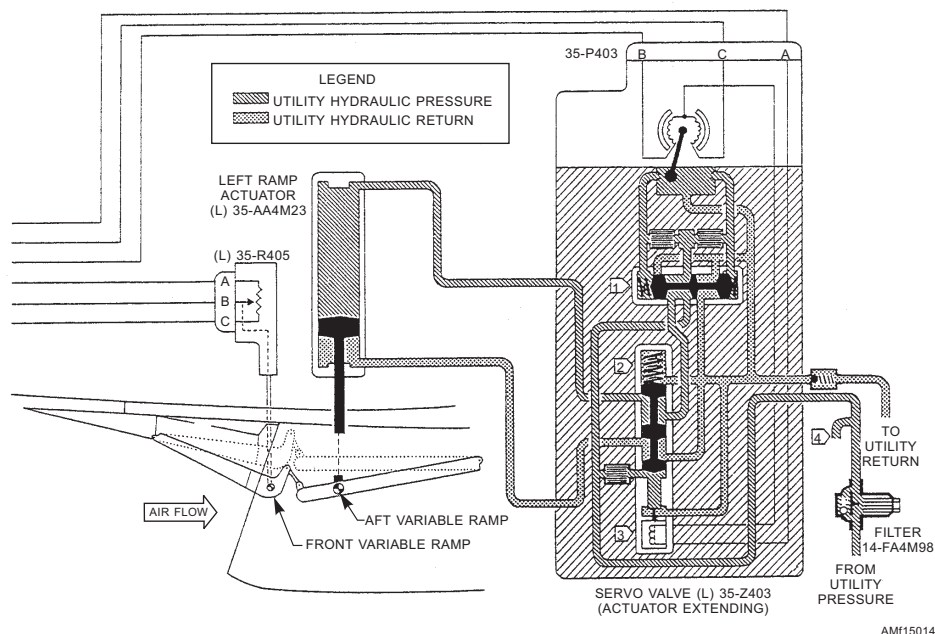

Figure 15-14.—Ramp servo and actuator.

ramp is positioned by the hydraulic actuator. The actuator is controlled by the electrically operated torque motor in the hydraulic servo valve.

Movement of the aft ramp positions the perforated ramp through mechanical linkage. The position of ramps is automatically selected through the ramp system by a temperature signal from the air data computer set. The ramp actuator is a double-acting cylinder attached to the ramp linkage in such a way as to be free floating. This arrangement causes equal action on the linkages attached to each end of the cylinder.

Figure 15-14 shows the complete hydraulic portion of the variable ramp system, showing the actuator extending. Actuating the torque motor armature positions the flapper valve in the servo valve, initiating the proper servo action to extend, retract, or hold the actuator in position. As the actuator moves, it positions the ramp through its mechanical linkage.

Electrical components in the circuit translate an electrical signal, proportional to the ramp movement, to balance the amplifier circuits and hold the servo and ramp at this designated position until a new temperature signal initiates a change. If electrical or hydraulic power failure occurs, air loads on the ramps will tend to cause the ramps to move toward the retract position.

The variable bypass bellmouth system monitors the inlet duct operation and indicates any corrective action, bypassing more or less of the airflow at the engine face, as shown in figure 15-15.

The system adjusts the bypass bellmouth ring position to maintain a preselected inlet airspeed and stable mass airflow through the inlet duct throughout the flight range of the aircraft. Movement of the bellmouth ring also controls the amount of secondary air bypassed around the engine for cooling. The valves in the bellmouth controller (fig. 15-15) are positioned by the inlet duct pressure differential and, in turn, direct hydraulic pressure to the bellmouth ring actuator, increasing or decreasing the bypass opening. The holes drilled in the bypass ring assure cooling air to the engine compartment when the ring is in the closed position.

Auxiliary air doors (not shown in fig. 15-15) open to supplement the bellmouth bypass system at low airspeeds and during ground operation to prevent overtemperature and/or reverse airflow in the engine compartment. These doors are located on the underside of the fuselage and open in flight, at high speeds, as required to prevent excessive air pressure differential between the engine compartment and outside ambient.

The auxiliary doors are held closed by hydraulic actuators, which are sized, to develop a force equivalent to the door area times the designated differential pressure. When the pressure limit is exceeded, the door is pushed open (varying amounts) to keep the engine compartment pressure from becoming excessive. As the engine compartment pressure is lowered, the hydraulic actuators will pull the doors closed.

The variable ramp, bellmouth bypass, and auxiliary air door systems are powered by the utility hydraulic

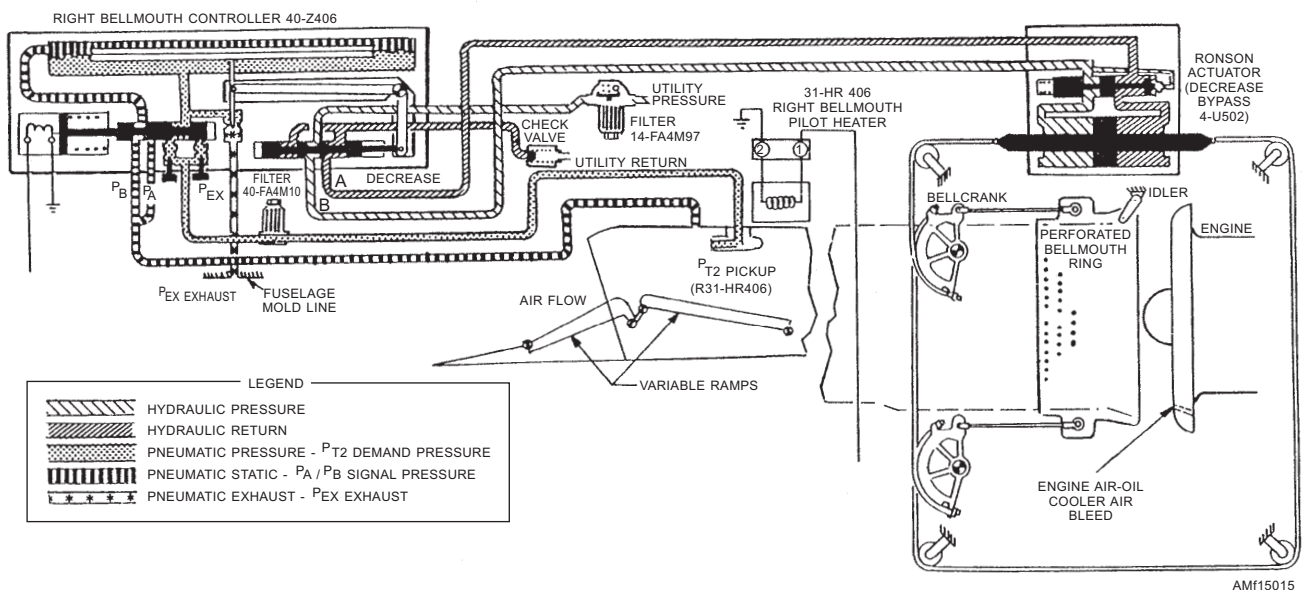

Figure 15-15.—Variable bellmouth system.

system. Malfunctions in these systems will normally require personnel of the AE, AD, and AM ratings working together to operationally test the system and provide proper corrective maintenance.

Q15-22. What systems decrease engine inlet air velocity to a subsonic flow with maximum pressure energy and provide for the reflection and bypass of surplus air not required by the engine with a minimum of drag?

Q15-23. What component controls the amount of secondary air bypassed around the engine for cooling?

BOMB BAY SYSTEM

LEARNING OBJECTIVES: Identify the types of bomb bay systems. Identify their components and applicable maintenance requirements.

The bomb bay system is shown in figure 15-16. The doors are actuated by mechanical linkage at each end. Each door mechanism is powered by two hydraulic-actuating cylinders.

The cylinders for the left door are powered by the No. 1 hydraulic system, and the cylinders for the right door are powered by the No. 2 hydraulic system. The main actuating levers are linked together so that in the event one system fails, the other will be capable of operating both doors. An unlock mechanism is incorporated in the forward linkage to secure the doors when hydraulic power is removed. A hand pump system provides for emergency opening and closing of the doors in the event both hydraulic and electrical systems fail. Shutoff valves are provided within each normal system and the emergency hand pump system to isolate the system. Two flow regulators are located upstream of the selector valve (dual system door control valve).

The control valve has three positions—DOORS OPEN, NEUTRAL, and DOORS CLOSED. In the DOORS OPEN position, fluid is ported to the dual controllable check valve, which bypasses pressure to the opening side of the uplock mechanism cylinder. As the cylinder retracts, it unlocks the mechanical uplocks, and then unseats the dual controllable check valve to port pressure to the open side of the door actuators.

The control valve is normally operated by a two-position switch located on the pilot's armament

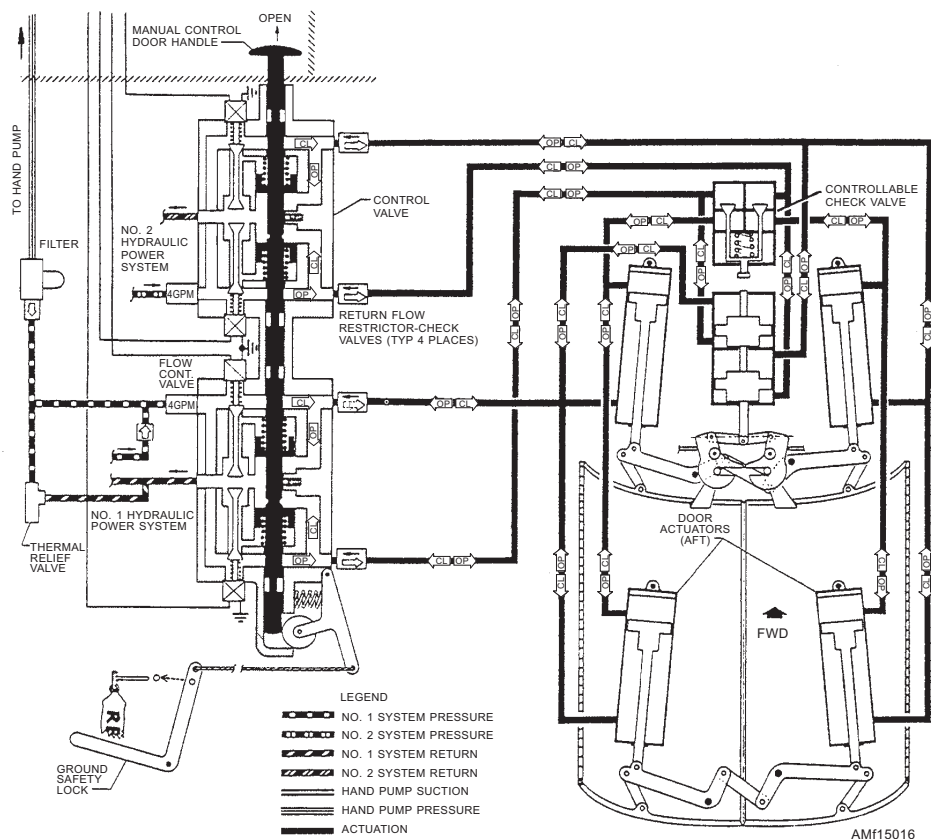

Figure 15-16.—Bomb bay door hydraulic schematic.

control panel. The switch energizes either pair of the four solenoids on the control valve to position the main spool to open or close the doors.

The uplock mechanism incorporates an overcenter feature, which prevents the assembly from locking until bearings on the doors trip the overcenter mechanism. Limit switches on the uplock mechanism break the electrical circuit to the control valve, and the spring-loaded valve returns to NEUTRAL. In this position, all fluid is ported to the return lines, and the doors are held closed by the mechanical locks. The one-way restrictors installed in the open and close lines ensure smooth door operation and prevent cavitation of the door-actuating cylinders.

Q15-24. How many positions does the door control valve have in the bomb bay system?

WINDSHIELD WIPER SYSTEM

LEARNING OBJECTIVES: Recognize the windshield wiper system. Identify its components and applicable maintenance requirements.

The windshield wiper system shown in figure 15-17 consists of a pressure reducer, speed control needle valve and drive mechanism, hydraulic actuator, two window actuator units and wiper blade assemblies,

and a return line check valve. System pressure is directed to the pressure reducer, where it is reduced to 2,000 psi, and then the fluid passes to the speed control valve, which starts, stops, and controls the wiper blade speed.

Hydraulic fluid is directed from the speed control unit to the hydraulic actuator, which, in turn, controls and directs fluid to the window units. The actuator alternately allows fluid flow to opposite sides of the window unit double piston. Constant speed of the wiper blades is provided by fluid from the speed control valve and is directed to the balance pistons in the hydraulic actuator. Fluid is also directed to the window units through the hydraulic actuator normal inlet port. The window units, by action of a rack and piston arrangement, convert the linear motion of the double piston to the reciprocating action of the drive shaft.

When the system has completed one wiper stroke and the hydraulic pressure at the window unit pistons reaches a value equal to system pressure minus 200 psi, the actuator will then reverse the flow to the opposite side of the window unit piston and repeat the wiper stroke action in reverse.

Any obstruction on one windshield will stop that blade, but allow the other to continue until it completes its stroke (or meets an obstruction), at which time the pressure in the window units build up and the actuator

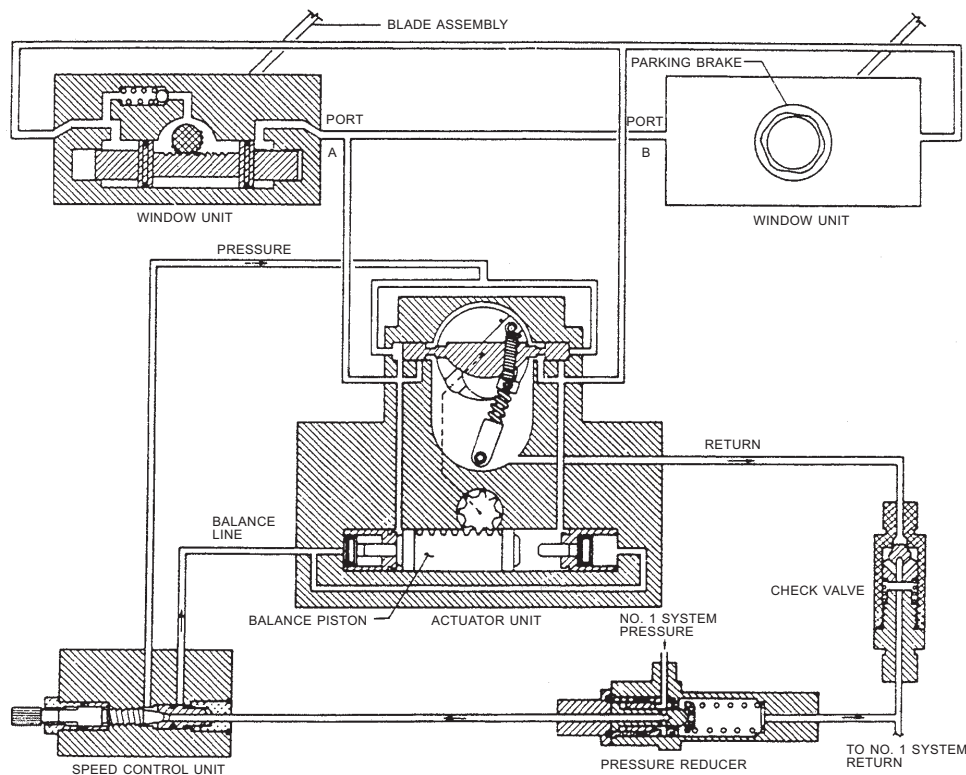

AM15017

Figure 15-17.—Windshield wiper schematic.

reverses the action of both blades. The mechanical locking device is provided to hold the blades in the parked position when the needle valve is closed.

NOTE: Do not operate the windshield wiper blades on a dry windshield.

Maintenance of the windshield wiper system consists mainly of operational checks, removal and installation of components, and troubleshooting.

The operational check should be performed according to the following procedures:

1. Provide a supply of water on the outside surface of the panels when the wiper blades are in motion.
2. Check for a wiper arm force of 7 to 10 pounds on the windshield (at the blade attachment).
3. Connect external electrical power supply.
4. Energize hydraulic power system No. 1 ac pumps.
5. Slowly open the windshield wiper speed control needle valve.
6. Blades must move from parked position and begin to cycle between 100 to 300 strokes per minute.
7. Open instrument panel to gain access to window units. Bleed air from units as they cycle by cracking the B-nuts on the tubing at each end of the window units. Allow fluid to bleed into existing drip pans until it is evident that all air has been removed.
8. Check that no hydraulic fluid leak is visible on the system tubing, connections, or at any component.

9. Check that system components perform smoothly with no erratic operation and blade reversing is synchronized. Blade rotation must be 75 degrees. The wiper blades must not touch the center post, travel into the parking area, or short cycle during high-speed operation.

10. Reduce speed of blade operation, and manually stall each wiper separately. While the blade is stalled, the opposite blade should operate smoothly.

11. Park the blades by slowing down the cycling speed to permit blades to move into the park position before they reverse.

NOTE: Parking area is the area between the bottom edge of the glass and the break in the contour of the fuselage. To adjust the blades, loosen the blade attaching screw and rotate blade. One serration is approximately 5 degrees of rotation. If it is not possible to install within the parking area, install the arm outboard with the blades as close to the parking area as possible, then remove the arm and adapter. Looking down on the arm, carefully remove the adapter and rotate it one serration counterclockwise with respect to the arm, and then reinstall the adapter in the arm. This will permit the arm to be installed approximately 1.25 inches closer to the parking area. If the blade is still parked on the glass, repeat the above procedure. Final adjustment must leave slots in the adapter and arm approximately in line to permit proper clamping action of the arm and adapter to the shaft of the window unit. Figure 15-18 illustrates a windshield wiper unit.

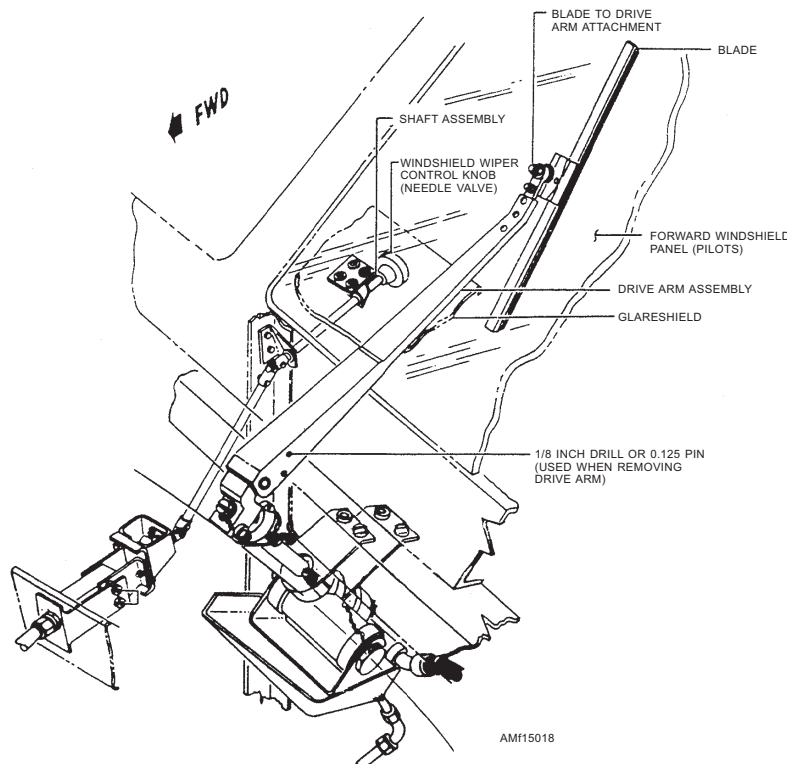

Figure 15-18.—Windshield wiper unit.

12. When the blades are in the park position, quickly close the needle valve.

13. De-energize hydraulic power system No. 1 ac pumps, and remove.

Q15-25. In the windshield wiper system, what action of the window units convert the linear motion of the double piston to the reciprocating action of the drive shaft?

CHAPTER 16

FIXED-WING FLIGHT CONTROL SYSTEMS

INTRODUCTION

A flight control system is either a primary or secondary system. Primary flight controls provide longitudinal (pitch), directional (yaw), and lateral (roll) control of the aircraft. Secondary flight controls provide additional lift during takeoff and landing, and decrease aircraft speed during flight, as well as assisting primary flight controls in the movement of the aircraft about its axis. Some manufacturers call secondary flight controls auxiliary flight controls. All systems consist of the flight control surfaces, the respective cockpit controls, connecting linkage, and necessary operating mechanisms.

The systems discussed in this course are representative systems. Values such as tolerances, pressures, and temperatures provide better understanding of the text material. You should bear in mind that these values are for representative units and are not accurate for all systems. When actually performing the maintenance procedures discussed, you should consult the current maintenance instruction manual (MIM).

FLIGHT CONTROL SYSTEMS

LEARNING OBJECTIVE: Identify the types of flight control systems.

A flight control system includes all the components required to control the aircraft about each of the three flight axes. A simple flight control system may be all mechanical; that is, operated entirely through mechanical linkage and cable from the control stick to the control surface. Other more sophisticated flight control systems may use electrical or hydraulic power to provide some or all of the “muscle” in the system. Still others combine all three methods.

MECHANICAL (UNBOOSTED) FLIGHT CONTROL SYSTEM

A typical, simple, mechanical (unboosted) flight control system is the one used in flight training aircraft. The flight control surfaces (ailerons, elevators, and rudder) are moved manually through a series of

push-pull rods, cables, bell cranks, sectors, and idlers. Figure 16-1 schematically illustrates the elevator portion of a mechanical (unboosted) flight control system. The control stick is mounted in such a way that it can pivot backwards and forwards on its mounting pin. The control stick is connected to a push-pull rod attached to its lower end. As the stick is moved fore and aft, it causes the elevators to be deflected proportionately.

The push-pull tube (rod) that connects to the lowest point of the control stick extends aft to the pulley. Notice that the function of the pulley is to change the direction of the push-pull action from fore and aft to up and down. The second push-pull tube (rod) connects the forward cable sector and the pulley, and causes the sector to rotate according to the stick movements.

From the forward sector, the cables extend back through the aircraft to the aft cable sector. They have been reduced in length so that the remaining essential components of the elevator control system may all be shown in one drawing.

The aft sector is essentially the same as the forward sector, and it acts as a slave to the forward sector. Cables from the forward sector attach to the aft edges of the aft sector. A push-pull tube from the aft sector connects to the elevator fitting assembly.

The elevator fitting assembly, commonly called the elevator “horn,” is built onto the elevators and extends outward (and usually downward) from the elevator surface at right angles to the plane of rotation and the chord line of the elevator surfaces. As the fitting assembly is moved fore or aft, the elevators are moved up or down.

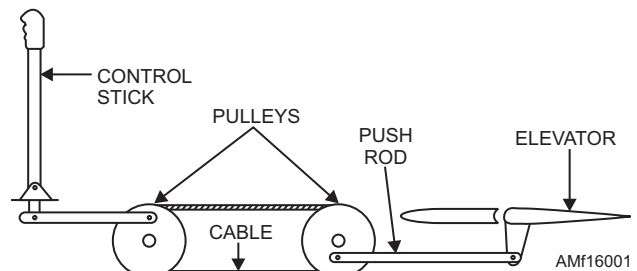

Figure 16-1.—Mechanical (unboosted) flight control system.

HYDRAULIC (POWER BOOST) FLIGHT CONTROL SYSTEM

Power-boosted flight control systems are used on high-speed jet aircraft. Aircraft traveling at or near supersonic speeds have such high airloads imposed upon the primary control surfaces that it is impossible for a pilot to control the aircraft without power-operated or power-boosted flight control systems. In the power-boosted system, a hydraulic actuating cylinder is built into the control linkage to assist the pilot in moving the control surface. The power-boost cylinder is still used in the rudder control system of some high-performance aircraft; however, the other primary control surfaces use the full power-operated system. In the full power-operated system, the force necessary to operate the control surface is supplied by hydraulic pressure. Each movable surface is operated by a hydraulic actuator (or power control cylinder) built into the control linkage.

Q16-1. What type of flight control provides additional lift during takeoff and landing?

Q16-2. What type of flight control system is used on high-speed jet aircraft?

Q16-3. What type of pressure supplies the force necessary to operate the control surface in a full power-operated system?

PRIMARY FLIGHT CONTROL SYSTEMS

LEARNING OBJECTIVE: Recognize the functions of the three primary flight control systems (longitudinal, lateral, and directional).

Different aircraft manufacturers call units of the primary flight control system by a variety of names. The types and complexity of control mechanisms used depend on the size, speed, and mission of the aircraft. A small or low-speed aircraft may have cockpit controls connected directly to the control surface by cables or pushrods. Some aircraft have both cable and a pushrod system. See figure 16-1. The force exerted by the pilot is transferred through them to the control surfaces. On large or high-performance aircraft, the control surfaces have high pressure exerted on them by the airflow. It is difficult for the pilot to move the controls manually. As a result, hydraulic actuators are used within the linkage to aid the pilot in moving the control surface. Figure 16-2 shows a mechanically

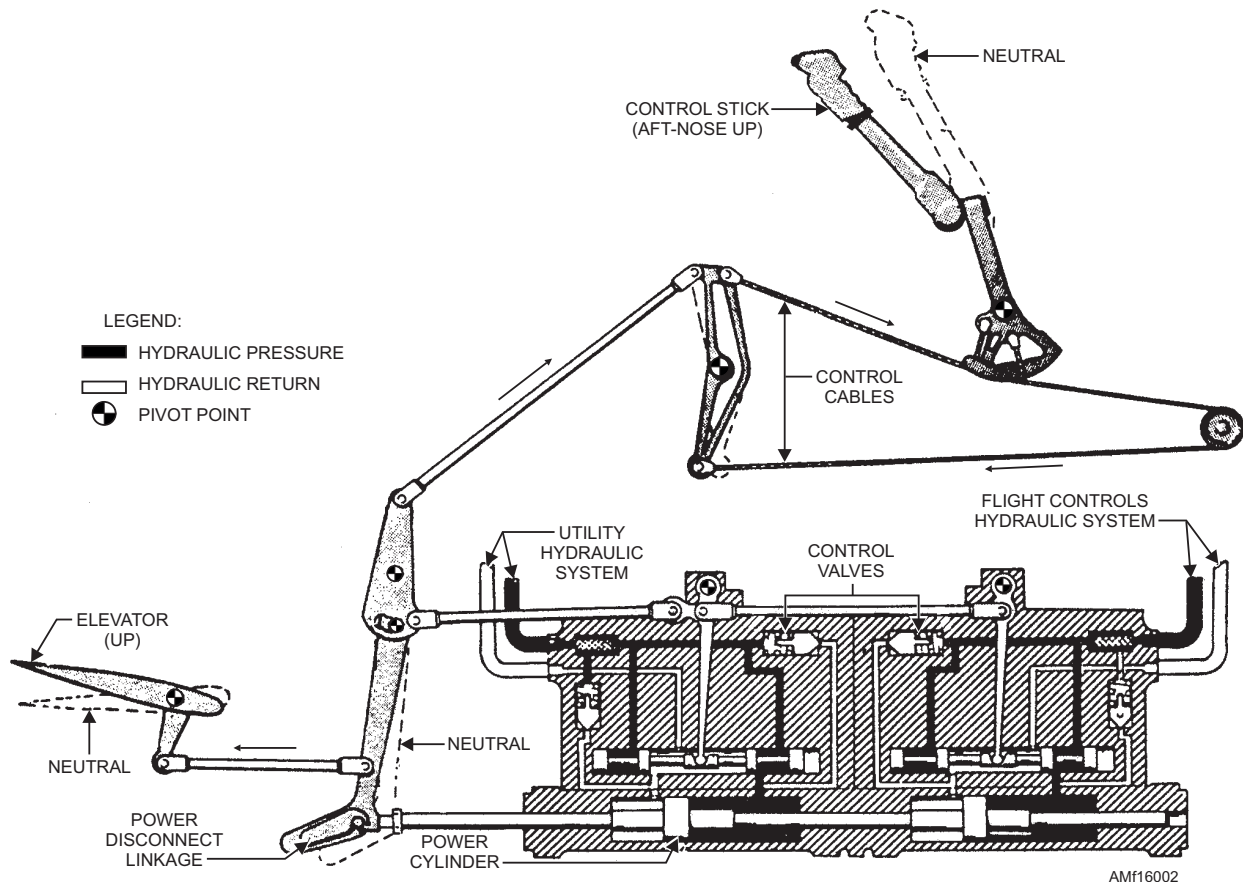

Figure 16-2.—Hydraulically powered elevator control system.

controlled, hydraulically assisted system. Because these systems reduce pilot fatigue and improve system performance, they are now commonly used. Such systems include automatic pilot, automatic landing systems, and stability augmentation systems.

Navy specifications require two separate hydraulic systems for operating the primary flight control surfaces. Current specifications call for an independent hydraulic power source for emergency operation of the primary flight control surfaces. Some manufacturers provide an emergency system powered by a motor-driven hydraulic pump. Others use a ram-air-driven turbine for operating the emergency system pump.

LONGITUDINAL CONTROL SYSTEMS

Longitudinal control systems control pitch about the lateral axis of the aircraft. Many aircraft use a conventional elevator system for this purpose. Aircraft that operate in the higher speed ranges usually have a movable horizontal stabilizer.

Elevator Control System

The elevator control system, shown in figure 16-2, is typical of many conventional elevator systems. It operates by the control stick in the cockpit and is hydraulically powered.

The operation of the elevator control system starts when the control stick is moved fore or aft. The movement of the stick transfers through the control cables to move the elevator control bell crank. The bell crank transmits the movement to the hydraulic actuating cylinder through the control linkage. The hydraulic actuating cylinder operates a push-pull tube, which deflects the elevators up or down.

The elevator system uses forward and aft bobweights. The bobweights induce a load on the control stick during pitching and vertical acceleration and prevent pilot-induced oscillations through the elevator controls. If the gravity force is increased on the bobweights, the induced load tends to return the control stick to the neutral position. Viscous dampers on the bobweight assemblies retard control stick movement to prevent overcontrol. Overcontrol could cause airframe overstress.

The elevator forward bobweight serves to help recenter the control stick when a heavy gravity load pulls against the airframe. The forward bobweight and damper assembly is in a housing forward of the control

stick in the cockpit. See figure 16-3. The assembly consists of a bobweight, a viscous damper, and a push-pull tube. The push-pull tube is the interconnect between the control stick and the bobweight. The damper is located at the pivot point of the bobweight and restricts fast movement of the bobweight.

The aft bobweight and damper assembly works with the forward assembly to overcome the heavy pull of gravity and retard the chance of overcontrol. See figure 16-4. This assembly is installed in the fuselage, forward and below the horizontal stabilizer. It connects to the elevator control cables.

The aft assembly consists of a bobweight, a viscous damper, and a load spring. The bobweight connects to the elevator control bell crank and the damper. The load spring is between the elevator control bell crank and the fin structure to balance the forward and aft bobweights when the elevator is in a neutral position.

The elevator power mechanism changes the mechanical movement of the control stick to the hydraulic operation of the elevator. See figure 16-5. The mechanism is in the aft section of the aircraft directly below the horizontal stabilizer. As in the aileron power system, the mechanism consists of a hydraulic power cylinder, control valves, linkage, and hydraulic piping.

When the elevator controls are operated, the control valves port hydraulic pressure to the power cylinder. The hydraulic pressure extends or retracts the cylinder piston to move the push-pull tubes. The push-pull tubes deflect the elevators. The control valves are two separate valves connected in tandem by linkage. One valve is supplied hydraulic pressure by

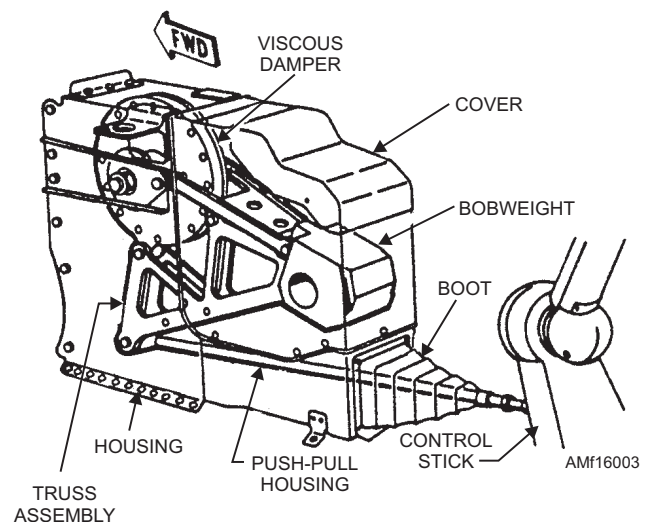

Figure 16-3.—Elevator forward bobweight and damper assembly.

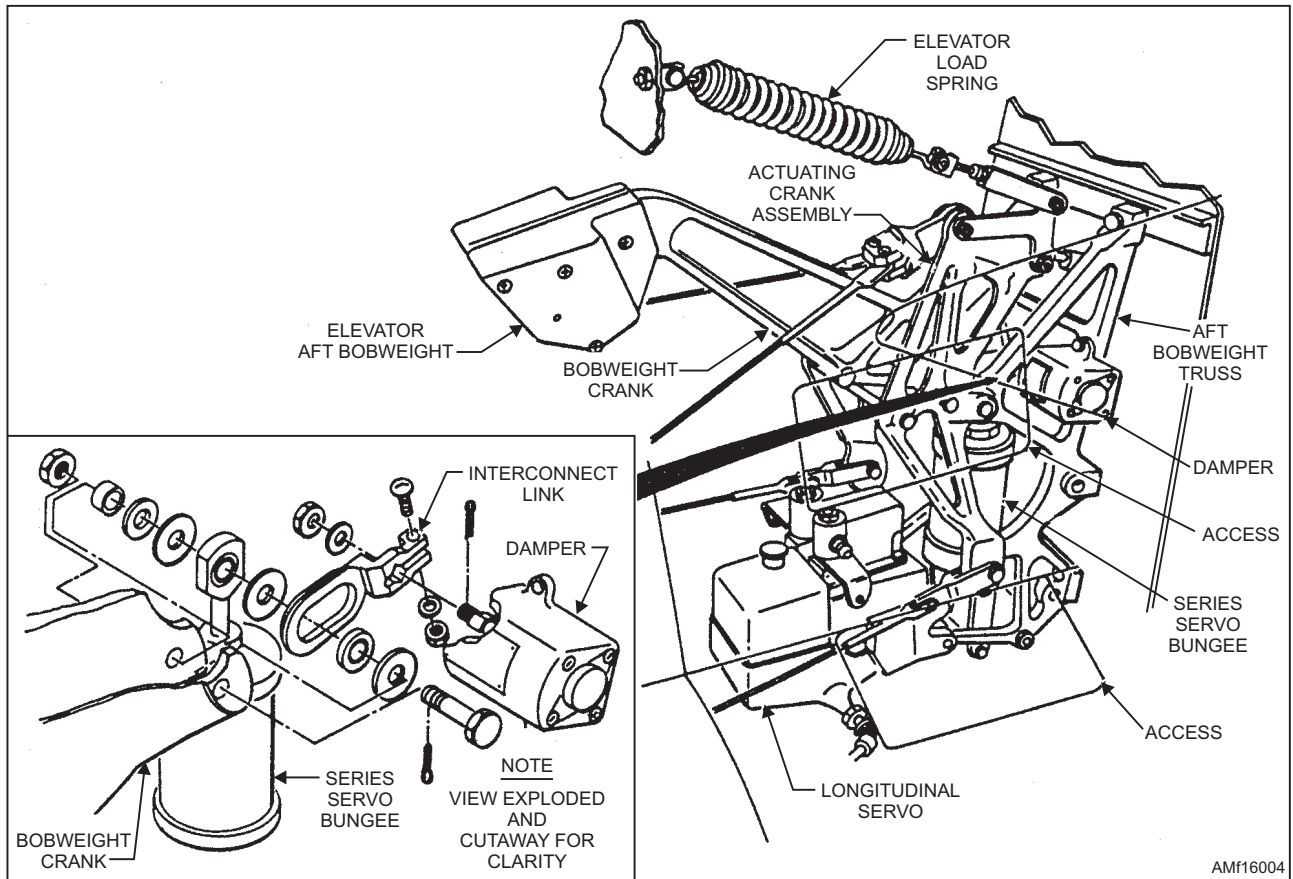

Figure 16-4.—Elevator aft bobweight and damper assembly.

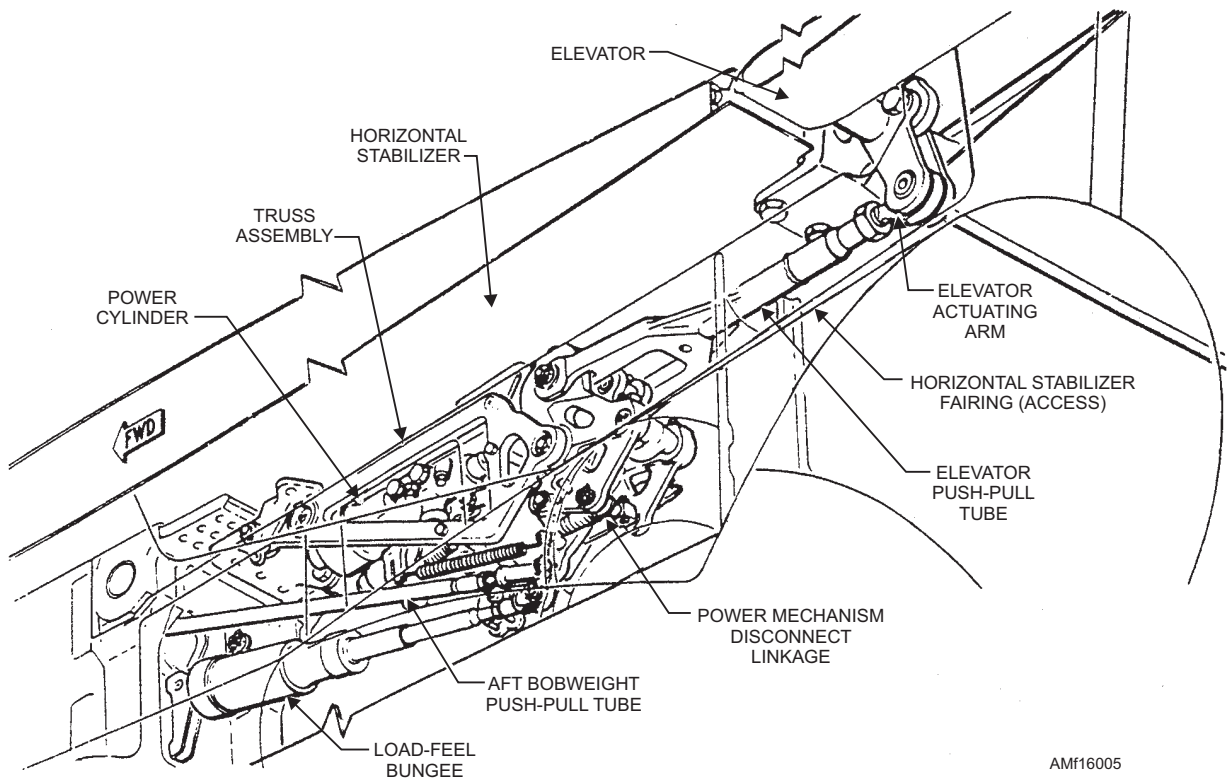

Figure 16-5.—Elevator power mechanism.

the utility hydraulic system. The other valve is supplied hydraulic pressure by the flight control hydraulic system. The power cylinder has dual hydraulic chambers to work from each control valve. Each hydraulic system simultaneously supplies 3,000-psi hydraulic pressure to the power mechanism. If one hydraulic systems fails, the other system supplies enough pressure to operate the mechanism. If both hydraulic systems fail, the cylinder disconnects by pulling the MAN FLT CONT (manual flight control) handle in the cockpit. The controls work manually through the linkage of the mechanism to operate the elevators.

The load-feel bungee, shown in figure 16-5, provides an artificial feel to the control stick. The bungee acts as a centering device for the elevator system. Control stick movement compresses the spring in the bungee. Releasing the control stick causes the compressed spring to return the stick to neutral. The bungee also adds a gearing effect between the horizontal stabilizer and the elevators. When the stabilizer is trimmed to give an aircraft nose up condition, the bungee action adds nose up elevator. With the stabilizer trimmed nose down, the bungee action adds nose down attitude on the elevator.

Horizontal Stabilizer Control System (Single Axis)

Various aircraft manufacturers identify the horizontal stabilizer control system by different

names. On one aircraft, it is called a unit horizontal tail (UHT) control system. On another aircraft, it is called the stabilizer control system. Regardless of the variation in nomenclature, these systems function to control the aircraft pitch about its lateral axis.

The horizontal stabilizer control system shown in figure 16-6 is representative of an S-3 aircraft. The slab-type stabilizer responds to fore-and-aft manual input at the control stick. It responds to automatic flight control system electrical signals introduced at the stabilizer actuator.

Pilot signals are conveyed through bell cranks and pushrods and a trim mechanism to the input linkage of the stabilizer actuator. A trim switch on the control stick grip provides a means of setting stabilizer trim. Stabilizer trim deflection is from -6° down to $+1^\circ$ up. Stabilizer trim is displayed by the stabilizer trim indicator located on the pilot's lower instrument panel. See figure 16-7.

The position of the stabilizer is shown on the integrated position indicator located on the left side of the pilot's instrument panel. When the stabilizer is in the "clean" configuration, the STAB window of the indicator shows the word CLEAN. When the stabilizer is in the "dirty" configuration, the window shows a picture of a stabilizer.

The stabilizer actuator (fig. 16-7) is a tandem-type actuator powered by both flight and combined system pressures. It contains a power valve shuttle, two

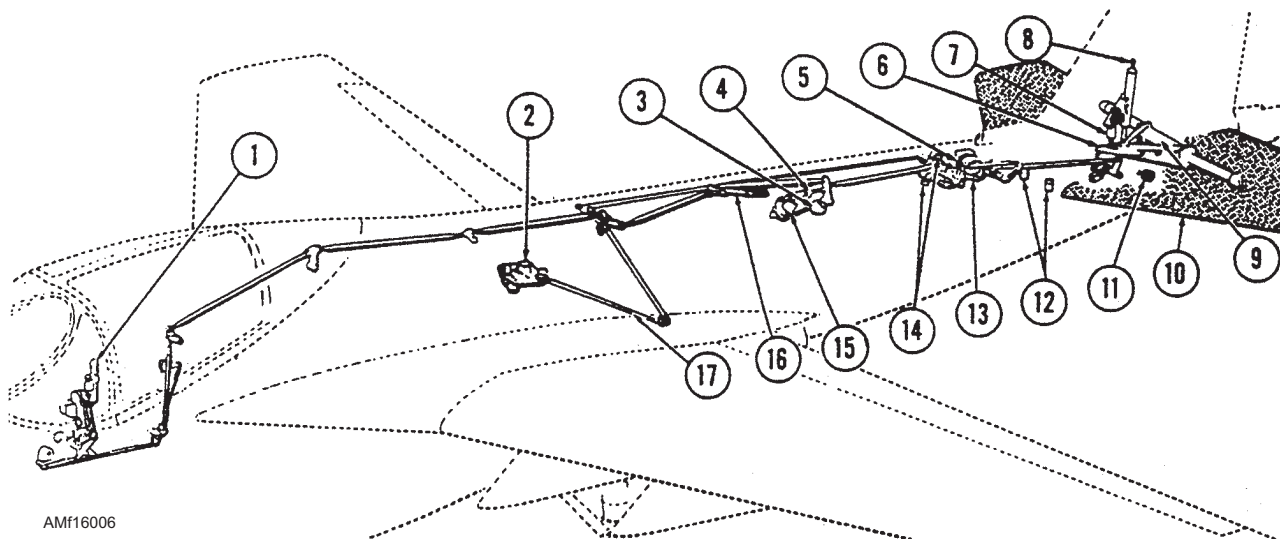

- | | | |
|-------------------------------|------------------------------------|---------------------------------------|
| 1. Control stick | 7. Load-relief bungee | 13. Negative bobweight |
| 2. Flap drive gearbox | 8. Stabilizer actuator | 14. Clean and dirty switches |
| 3. Trim transmitter | 9. Stabilizer support shaft | 15. Electrical trim actuator |
| 4. Artificial feel bungee | 10. Stabilizer | 16. Static spring |
| 5. Stabilizer shaft mechanism | 11. Stabilizer position transducer | 17. Stabilizer shift mechanism cables |
| 6. Walking beam | 12. Filters | |

Figure 16-6.—Stabilizer control system.

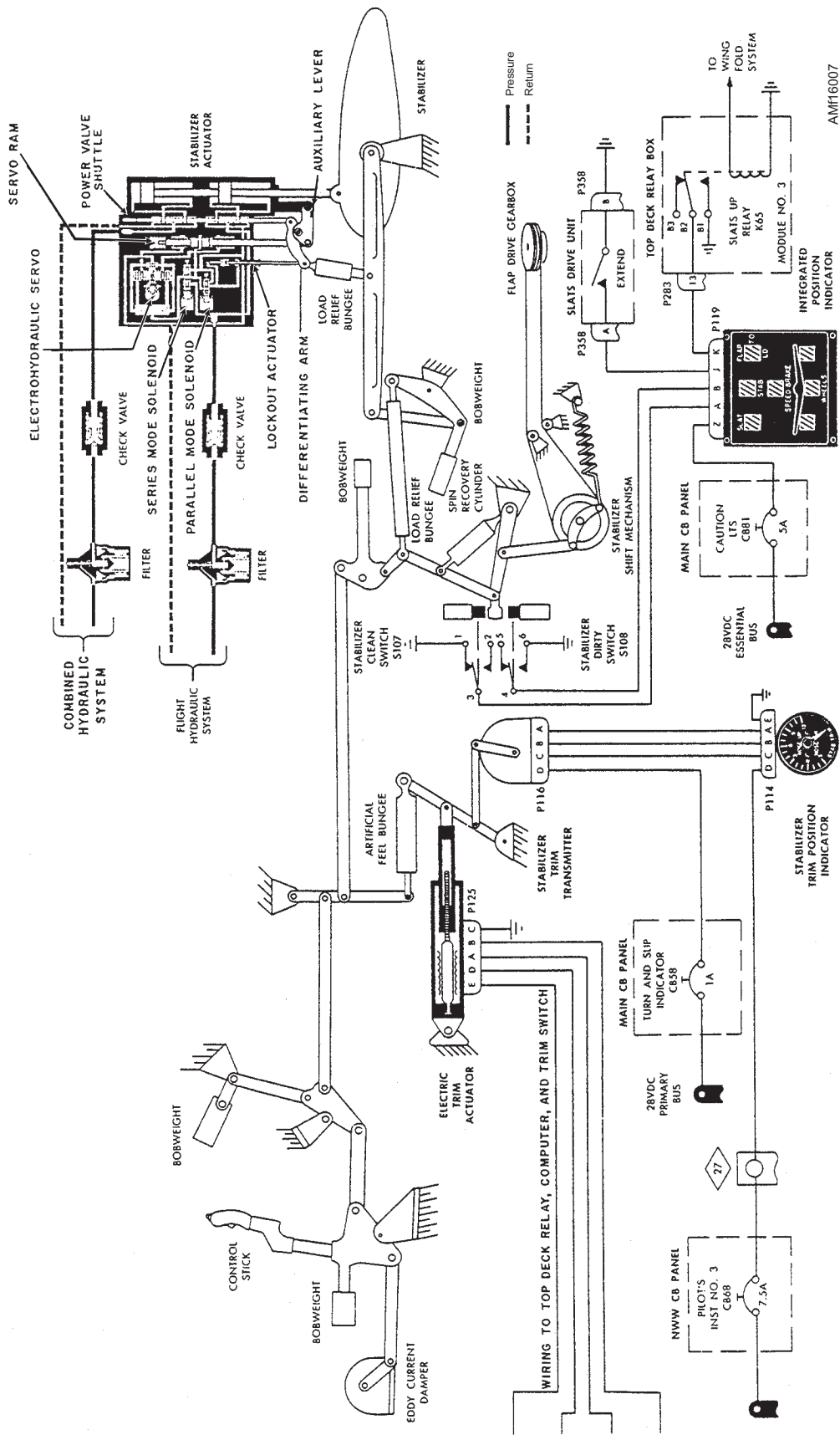

Figure 16-7.—Stabilizer control system schematic.

tandem-mounted power pistons, a servo ram, an electrohydraulic servo valve, a lockout actuator, and parallel and series mode solenoid valves. The actuator can operate in any of three modes—manual, series, or parallel. Refer to figure 16-7 to help you understand the three modes of operation.

MANUAL MODE.—In this mode, the pilot input alone controls the power valve. Inputs are transmitted through linkage to the mechanical input lever. The auxiliary lever is locked in neutral by the servo ram centering springs, causing the mechanical input lever to rotate about its pivot point, moving the power shuttle valve. As the valve shuttle is displaced from neutral, a valve error is established, and pressure is ported to the actuating pistons. The pressure moves the pistons and the attached stabilizer in proportion to the input.

A mechanical feedback is transmitted through the differentiating lever, the load-relief bungee, and the mechanical input lever back to the power valve shuttle, causing it to return to the neutral position.

For a constant velocity pilot input, a small constant valve error is established, and the stabilizer moves at a constant speed. When the pilot input stops, the power shuttle valve is returned to neutral, and the stabilizer stops until a new input is introduced.

SERIES MODE.—In this mode, input signals from the automatic flight control system (AFCS) may be used independently or combined with manual input to control stabilizer movement. The series mode solenoid valve is energized, porting flight system hydraulic pressure to the electrohydraulic servo valve. Input signals from the AFCS amplifier are applied to the coils of a torque motor in the servo valve, regulating flow from the valve to the servo ram.

The servo ram is connected to the auxiliary lever. Movement of the lever moves the mechanical input lever floating-pivot point. This movement causes mechanical input lever rotation about the manual input point and moves the power shuttle valve, causing a valve error.

A linear transducer, mounted on the servo ram centerline, provides electrical feedback signals to the AFCS. Mechanical feedback is provided by the differentiating lever, as in the manual mode. When operating in the series mode, control surface displacement is not reflected at the control stick.

PARALLEL MODE.—In this mode, stabilizer movement is controlled by input signals from the AFCS alone. Both series and parallel mode solenoid

valves are energized. Flight system pressure is ported to the electrohydraulic servo valve and the mechanical input lockout piston. Fluid pressure stabilizes the lockout piston and holds the mechanical input lever.

The transducer mounted on the servo ram provides an electrical signal feedback to the AFCS. There is no mechanical feedback, since the mechanical input is locked. Additional electrical signal feedback is provided by a transducer, which is mechanically linked to the stabilizer actuating arm. In the parallel mode, the control stick follows the motion of the stabilizer. Should the pilot desire to override the AFCS, he/she can overpower the lockout actuator with a stick force of 24 pounds.

Stop bolts are attached to the control stick pedal to limit fore-and-aft stick movement. The eddy current damper dampens out any rapid fore-and-aft stick movement.

All joints between the pushrods and bell cranks or idlers contain self-aligning bearings to compensate for any misalignment during operation and airframe deflections in flight that might cause binding.

Artificial feel is provided by the artificial-feel bungee. The bungee consists of two springs, which have different spring constants. The stick force caused by the bungee is proportional to stick displacement. At near neutral, the bungee provides a high stick force that decreases a short distance from neutral and gradually increases with the amount of stick displacement.

The electric trim actuator is mechanically linked to the artificial-feel bungee, and varies the neutral position of the bungee to provide longitudinal trim of the aircraft. The actuator consists of one high-speed and one low-speed motor, a gearbox, a brake, a ball detent clutch, and a threaded power screw. The actuator is manually controlled through inputs from the trim switch on the control stick grip. When the stabilizer is in automatic trim, the actuator receives inputs from the AFCS. High speed is used during manual trim, and low speed during automatic trim.

The stabilizer shifting mechanism, shown in figure 16-7, consists of a shift sector and its linkage, plus cable that runs from the flap drive gearbox and the rudder cam shift mechanism. A spin recovery cylinder is also attached to the shifting mechanism, and provides an alternate method of shifting the stabilizer and rudder from the “clean” configuration to the “dirty,” or increased throw configuration.

In normal operation, when flaps are extended, a cable running from a drum on top of the flap drive gearbox to the sector assembly of the shifting mechanism rotates the sector. Linkage connecting the sector assembly and the control stick linkage is shifted. Linkage shifting increases control stick travel. Stabilizer down travel is increased to a 24-degree maximum. A cable is also connected from the sector assembly to the rudder cam stop shifting mechanism, which increases rudder travel from 4 to 35 degrees each side of neutral.

The pilot, at his/her option, may obtain increased stabilizer and rudder throw by actuation of the spin recovery assist switch, eliminating the necessity of lowering the flaps. This action ports hydraulic pressure through the spin recovery selector valve and its flow regulators and check valve to the spin recovery cylinder, causing it to extend and shift the mechanism in the same manner as provided by the cable action.

The two nonbypass-type filters in the system protect the intricate valving mechanisms of the actuator from contamination, and are vitally important to proper stabilizer operation. They are checked with the requirements listed in the maintenance requirements card deck, and should not be overlooked when troubleshooting stabilizer system malfunctions.

The stabilizer power package, used on various Navy aircraft, is linked to the approach power compensator system (APC). This system aids the pilot in maintaining optimum angle of attack for approach and landing. An APC potentiometer is mechanically linked to the power package, and provides electrical inputs to the APC system to compensate for changes in pitch attitude required during landing approaches. The APC system regulates the throttle position to provide the engine thrust required to establish and maintain the desired angle of attack. The potentiometer provides inputs relative to the position of the horizontal stabilizer.

Horizontal Stabilizer (Stabilator) Control System (Double Axis)

Because of the complexity and interrelationships of the flight control systems of newer model aircraft, only a brief description of a representative stabilizer/stabilator control (pitch/roll axis) (F/A-18) follows. This system allows pitch about the aircraft's lateral axis and roll about the aircraft's longitudinal axis.

The stabilator is a control surface located on either side of the tail section of the aircraft. In flight, the stabilator deflects symmetrically to produce pitch motion and asymmetrically to produce roll motion. The maximum surface deflection of each stabilator is from 10.5 degrees trailing edge down to 24 degrees trailing edge up.

LATERAL CONTROL SYSTEMS

Lateral control systems control roll about the longitudinal axis of the aircraft. Several of the different system arrangements used by aircraft manufacturers are discussed, as well as general maintenance requirements for primary flight control systems.

Aileron Control System

The aileron control system, shown in figure 16-8, is equipped with a power mechanism that provides hydraulic power to operate the ailerons. If hydraulic power fails, the mechanism can be disconnected, placing the system in complete manual operation. Movement of the aileron control system begins when the control stick in the cockpit moves left or right. When the stick is moved, cables connected to the bell crank in the control stick housing are moved to operate the sector on the power mechanism. With the actuation of the sector, the power mechanism operates, transferring the movement to the mechanical linkage that operates the ailerons.

The aileron power mechanism consists of two control valves, a dual-chambered hydraulic power cylinder, cable sectors, and a system of latches and related cranks. Linkage connects the control valves in tandem. The flight control hydraulic system powers one valve, and the other is powered by the utility hydraulic system.

The power cylinder is a single tandem cylinder, composed of four chambers with pistons connected to a common shaft. Each of the two control valves operates on that portion of the power cylinder to which it is associated. Both hydraulic systems operate simultaneously, and each delivers 3,000-psi pressure to the mechanism. If one hydraulic system should fail, the other system will supply enough power to operate the ailerons at reduced hinge movement.

When the control stick moves, the control cables move the power mechanism sector. Through linkage, the sector operates the control valves, which direct hydraulic fluid to the power cylinder. The cylinder actuating shaft, which is connected to the power crank

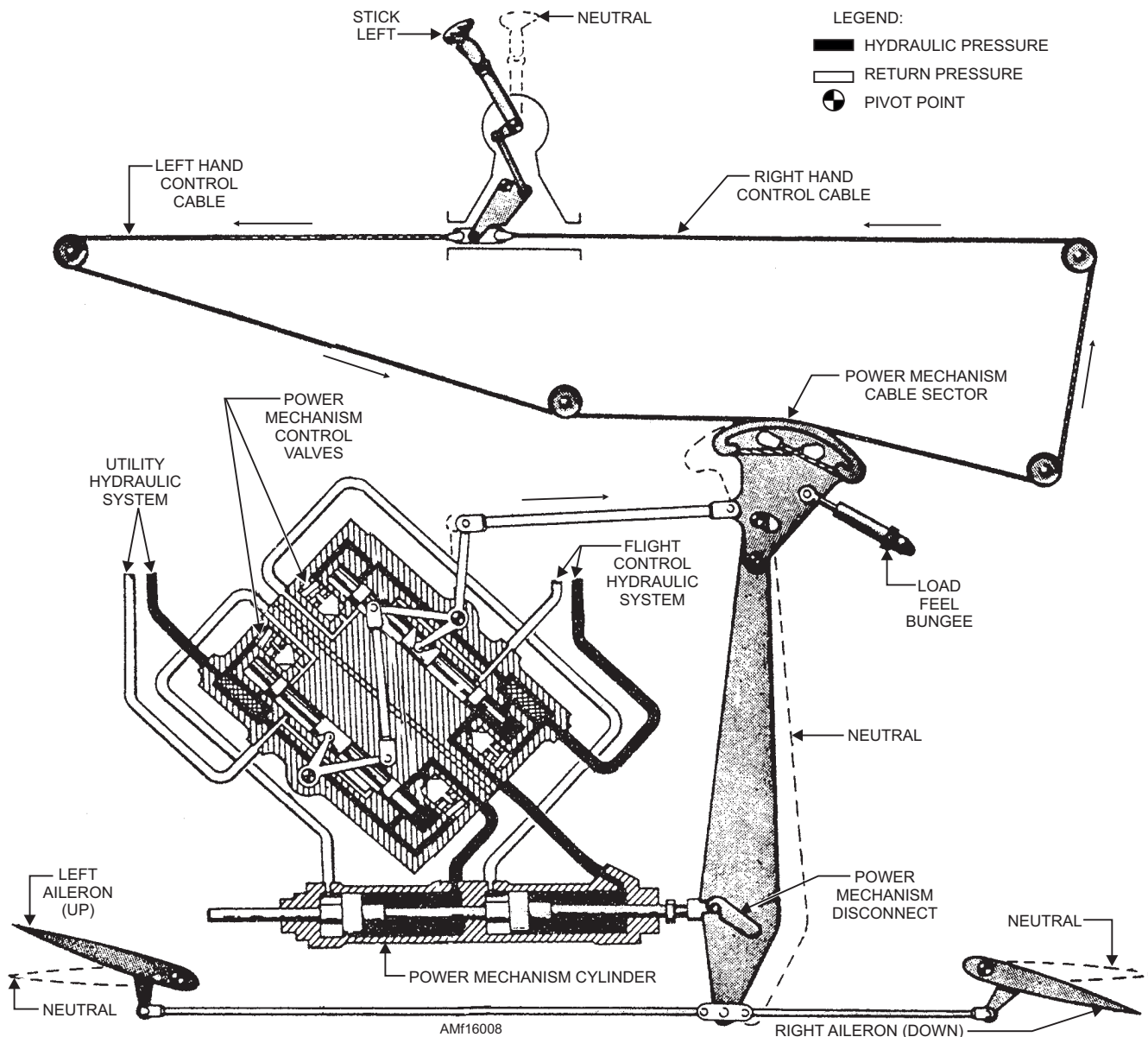

Figure 16-8.—Hydraulically powered aileron control system.

through a latch mechanism, operates the power crank. The crank moves the push-pull tubes, which actuate the ailerons. In the event of complete hydraulic power failure, a handle in the cockpit may be pulled to disconnect the latch mechanisms from the cylinder. When the handle is pulled, it places this particular aileron system in complete manual operation. In manual operation, the power cylinder is disconnected from the cable sector, causing the control stick to manually move the ailerons at a reduced rate.

The lateral control system incorporates a load-feel bungee, which serves a dual purpose. See figure 16-9. The bungee provides an artificial feel and centering device for the aileron system. It is interconnected between the aileron system and the aileron trim system. Energizing the aileron trim actuator moves the

bungee operating the power mechanism, which repositions the aileron control system to a new neutral position.

In normal operation of the control system, when the control stick is actuated left or right, the power mechanism compresses the bungee. The compressed bungee returns the stick to the neutral position upon release of the stick.

Flaperon Control System

The flaperon control system, shown in figure 16-10, is an example of lateral control provided by an electrohydraulic-mechanical flaperon system. The system includes an inboard and outboard flaperon for each wing and three actuators (a single flaperon

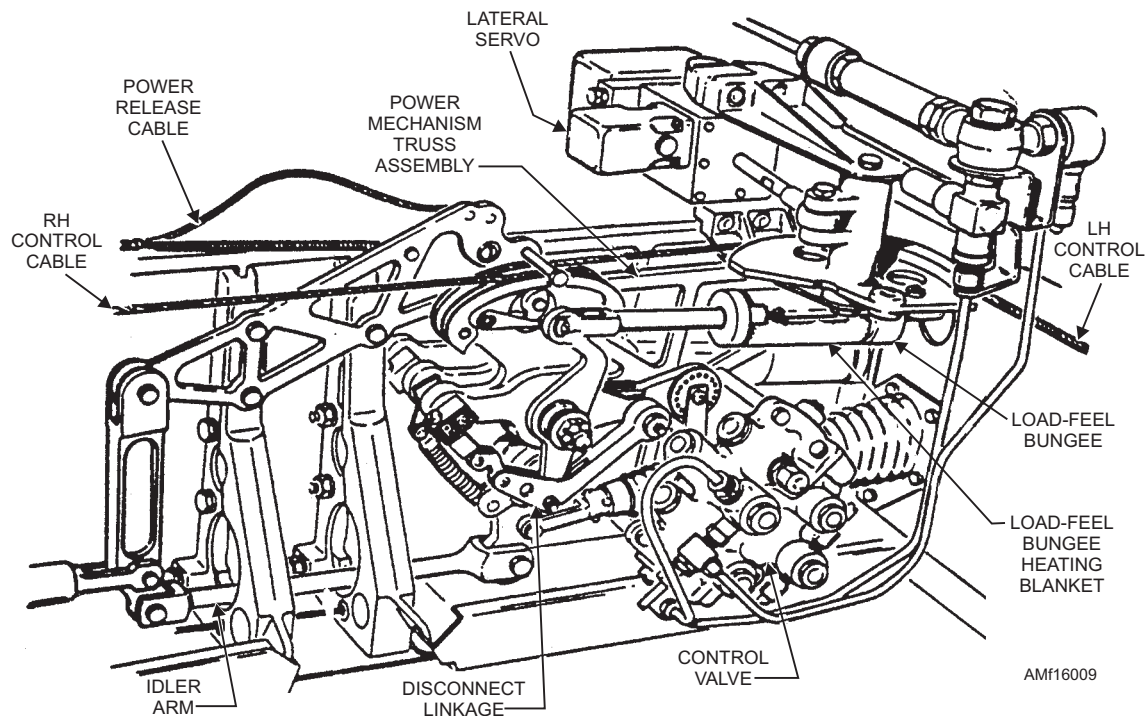

Figure 16-9.—Aileron power mechanism.

autopilot actuator and a flaperon power actuator in each wing).

Control stick movement, left or right, raises the respective two flaperons, while the opposite two remain flush with the wing. Full throw of the control stick by the pilot causes the inboard flaperon to rise 49 1/2 degrees and the outboard flaperon to rise 53 degrees. In flight, the flaperon can also be positioned by the AFCS. Control stick movements are transferred through the pushrod and bell crank system to the flaperon autopilot actuator. Mechanical outputs from this actuator are conveyed to a gearing mechanism, at which point linkage to the left and right wing flaperon power actuators separates. The gearing mechanism transmits movement to the left or right flaperon, while the opposite flaperon is maintained flush with the wing. When the flaperon pop-up cylinder is actuated, the gearing mechanism transmits pop-up motion to each wing flaperon power actuator.

The semiautomatic flaperon pop-up device aids in reducing ground roll during landing. The pop-up system is activated by the pilot placing the flaperon pop-up switch in the ARM position. All flaperons (four) will then automatically pop up approximately 41 degrees when the aircraft weight is on the landing gear and the throttles are retarded.

A mechanical interlock device prevents damage to the flaperons during folding of the wings. When the wings are folding, the flaperons cannot be extended. In

addition, the folding operation cannot start unless the flaperons are flush with the wings.

A wing-fold interlock prevents flaperon pop-up after the wings are folded. A fail-safe spring returns the flaperons to the flush position in case the combined hydraulic system or electrical system should fail.

The eddy current damper links mechanically to a bell crank in the flaperon control linkage. See figure 16-11. It dampens any rapid left or right control stick movement by producing an opposing force proportional to the speed at which the stick is moved. The damper contains permanent magnets, a rotating copper disc, a gear train, and a clutch assembly. Control stick motion rotates the clutch and gear train, which, in turn, rotates the copper disc. The copper disc is sandwiched in the air gap between the six permanent magnets and a flux plate. As the copper disc revolves, the magnetic field between the magnets and the flux plate is disturbed, causing an opposing force (eddy currents) that tries to stop the disc. The opposing force is proportional to the speed of the rotating disc and to the speed of stick movement. The clutch will slip at a force of 275 to 325 inch-pounds to prevent control stick binding if the damper jams.

Figure 16-12 illustrates a representative flaperon control system. The flaperon autopilot actuator is powered by the flight hydraulic system and transmits mechanical movement to the flaperon power actuators. The flaperon power actuators are tandem type and

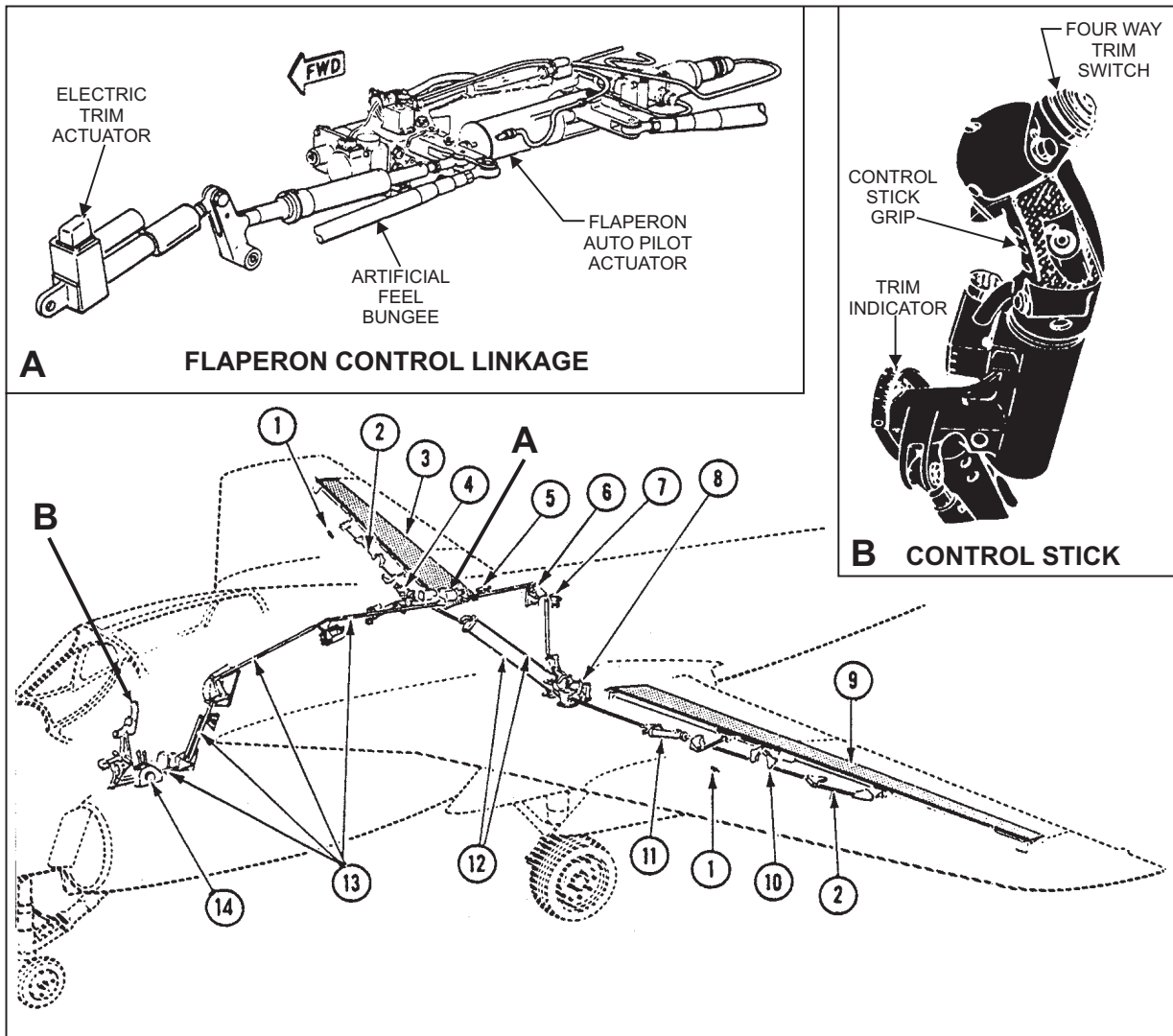

AMF16010

- | | |
|--|---|
| <ol style="list-style-type: none"> 1. Wing-fold flaperon interlock switch 2. Flaperon control linkage 3. Right wing flaperons 4. Flaperon actuator (right wing) 5. Flaperon pop-up valve 6. Wing-fold interlock mechanism 7. Filter | <ol style="list-style-type: none"> 8. Flaperon pop-up mechanism and cylinder 9. Left wing flaperons 10. Flaperon control linkage 11. Flaperon actuator (left wing) 12. Crossover cables 13. Pushrods 14. Throttle quadrant |
|--|---|

Figure 16-10.—Flaperon control system.

powered by the combined and flight hydraulic systems. They are capable of operating on only one system if one system should fail.

The artificial-feel bungee provides an initial control stick preload and increased force feel over the full range of stick displacement. The electromechanical actuator provides lateral trim, which varies the neutral position of the artificial-feel bungee. Trim is set by the switch on the control stick grip. The pilot may read the mechanical flaperon trim indicator on the control stick.

AUTOPILOT ACTUATOR.—The flaperon autopilot actuator (figs. 16-12 and 16-13) contains an electrohydraulic servo valve, actuator pistons, solenoid valve, transducer, series link, and series-link rod. It indirectly controls flaperon movement in response to mechanical movements from the pilot. It receives electrical inputs from the automatic flight control system. The actuator can operate in two modes—manual or series.

In manual mode, the solenoid valve is de-energized and no fluid is ported to any part of the actuator. The actuator piston rod is free to idle. The

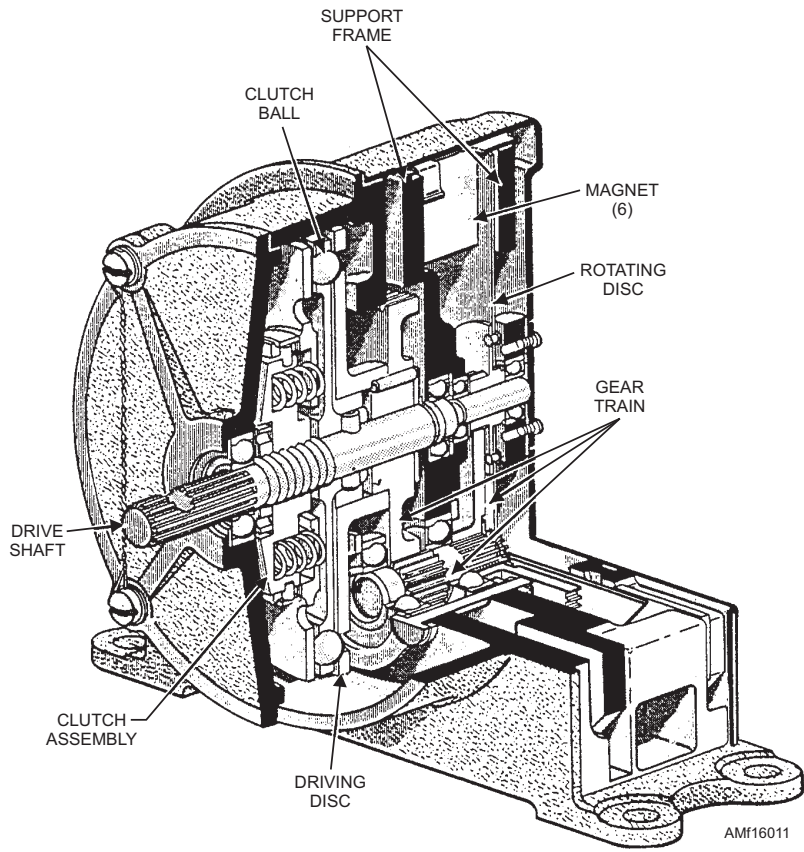

Figure 16-11.—Eddy current damper.

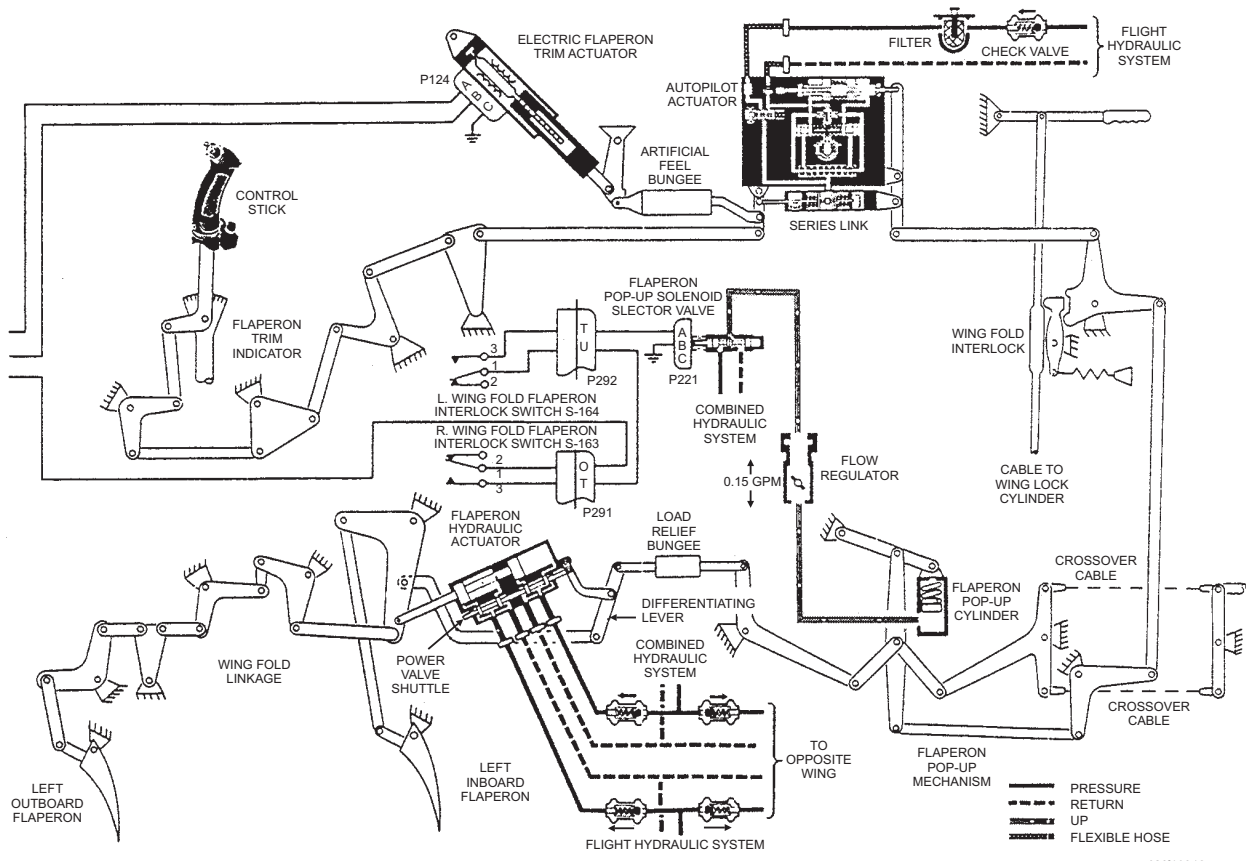

Figure 16-12.—Flaperon control system.

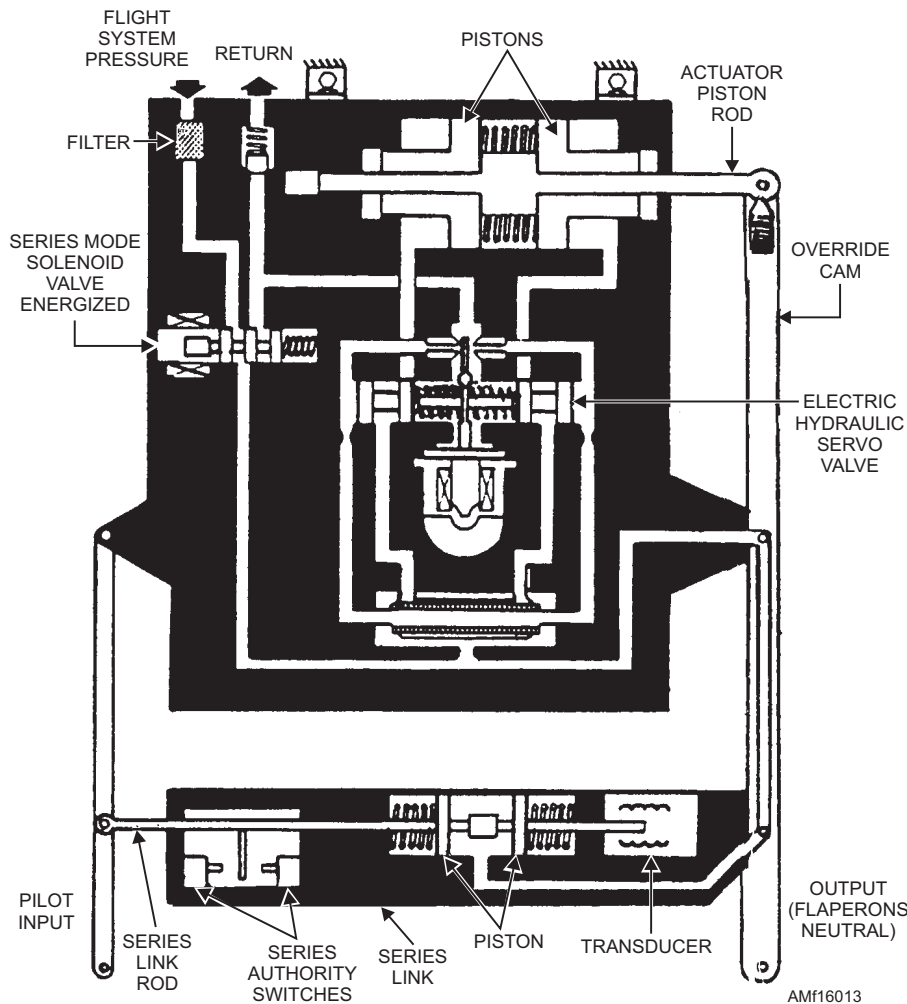

Figure 16-13.—Flaperon autopilot actuator.

series-link cylinder acts as a rigid link that transfers input lever motion to the output lever.

In series mode, the solenoid valve energizes and ports pressure to the servo valve. Pressure from the servo valve drives the actuator pistons together. This pressure causes the pistons and the rod to act as one piece. When the servo valve is at null, pressures in the piston end chambers are equal. Electrical signals from the automatic flight control system cause the electrohydraulic servo valve to differ the pressures in the end chambers. The signal provides the working force for the actuator. The actuator piston rod drives the output lever. Pressure at the series link compresses a lock spring, unlocking the series link. The actuator can stroke the pilot-commanded piston. When the pilot moves the input link, relative motion between input and output causes the transducer to send a signal to the AFCS amplifier. The signal combines with other flight stability signals, and the resultant signal operates the servo valve. The AFCS can be overridden by the pilot applying a stick force of 25 pounds.

SYSTEM ACTUATORS.—The flaperon system actuators directly control the flaperon movement in response to mechanical movement from the autopilot actuator. The actuator (fig. 16-12) consists of two tandem-mounted power pistons and a power valve shuttle. Mechanical inputs are introduced through the load-relief (safety) bungee and the valve input lever to the power valve shuttle portion of the actuator. The inputs cause a valve error and the porting of hydraulic pressure to the power pistons. As the flaperon moves, mechanical linkage attached to the actuator tends to null this valve error. The power valve shuttle returns to neutral. The flaperons remain in the selected position until new mechanical inputs are received from the pilot or the AFCS.

Combination Aileron/Spoiler Deflector System

Navy aircraft employ more than one system for lateral control of the aircraft. Figure 16-14 shows an aileron and spoiler/deflector arrangement to achieve an increased roll rate about the longitudinal axis.

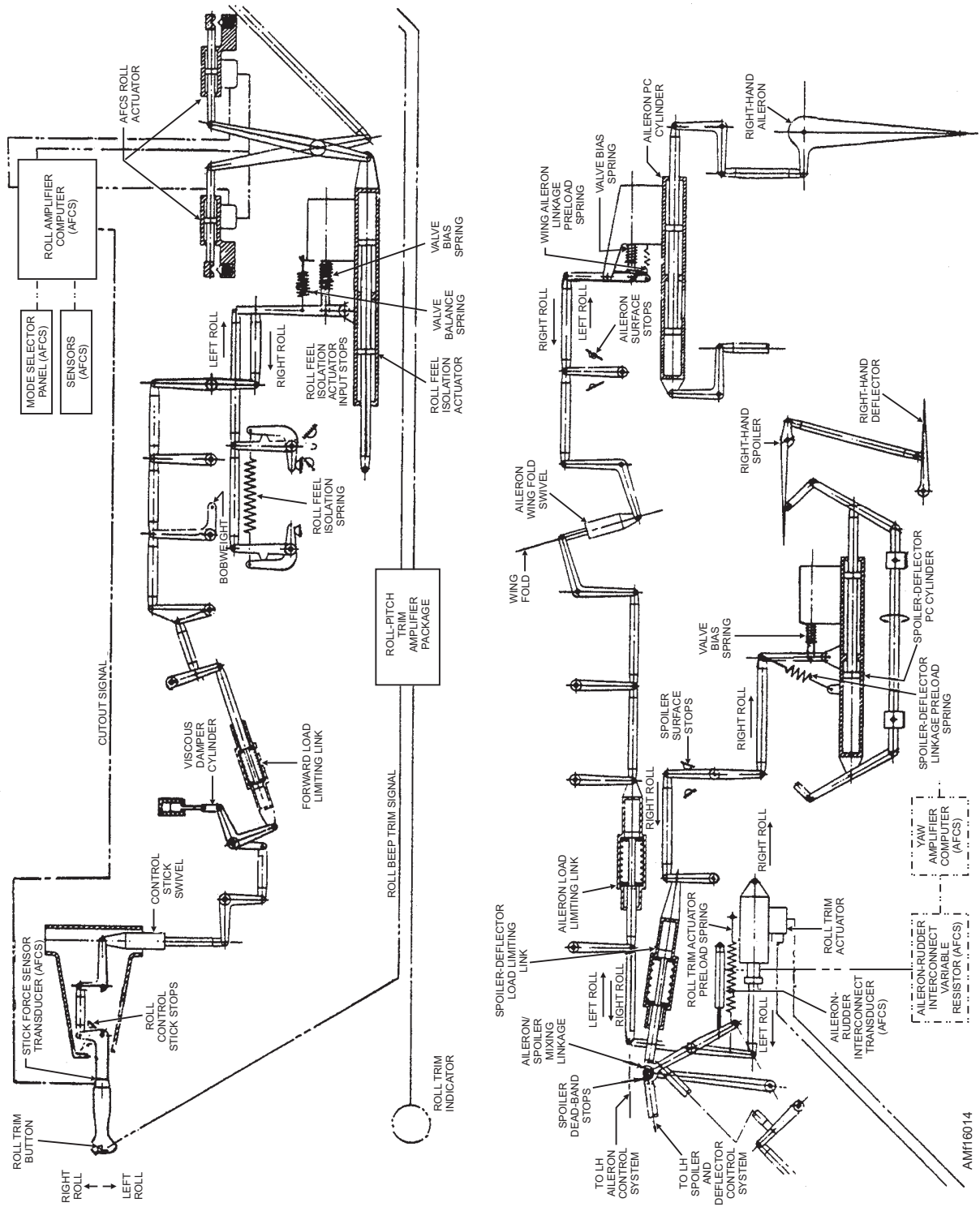

Figure 16-14.—Aileron and spoiler/deflector system.

In this system, left and right control stick movements transfer mechanically to the aileron and spoiler/deflector control linkage. The viscous damper cylinder is connected in the linkage. It resists rapid control stick movement, presenting overcontrol of the aileron system when the control augmentation mode of the AFCS is engaged. The control augmentation mode of the AFCS improves lateral and longitudinal stability of the aircraft.

The load-limiting links located throughout the system protect control linkage and components from excessive loads. These links have a breakout force, so they normally act as a fixed link. Loads that exceed the breakout force cause the links to extend or retract and absorb the overload.

Artificial feel is provided by the mechanical feel spring assembly. The assembly simulates air load resistance at the control stick. When released, the control stick returns to neutral by the feel spring preload.

The roll-feel isolation actuator prevents excessive forces from reaching the control stick. When the control stick is deflected, linkage to the feel isolation actuator servo valve repositions the servo valve slider and directs hydraulic pressure to the actuating pistons. The cylinder housing is connected to the control linkage and moves in the direction corresponding to stick movement. As the cylinder housing moves, the servo valve slider repositions to neutral, blocking fluid flow to and from the actuator until new inputs are initiated.

The AFCS roll actuator connects to the control linkage by a scissor link. Normally, this scissor link acts as a simple idler. When the actuator receives signals from the AFCS, it causes the linkage to act as a variable link. This action produces control system inputs completely independent of the control stick.

Output motion from the AFCS linkage is transmitted through control system linkage to the aileron trim and mixing linkage. The mixing linkage directs inputs to both the aileron and spoiler/deflector linkage. Dead-band stops within the mixing linkage allow the ailerons to reach a trailing edge up position of 2 degrees 30 minutes, ± 15 minutes, before any spoiler/deflector motion is initiated.

The power control cylinders for the ailerons and the spoiler/deflectors are tandem type. Power control No. 1 and power control No. 2 hydraulic systems supply hydraulic pressure. Half of the servo valve on each cylinder directs PC No. 1 hydraulic pressure to

the corresponding half of the PC cylinder. The second half of the servo valve directs PC No. 2 hydraulic pressure to the other half of the cylinder. If one system fails, the other system operates the ailerons and spoiler/deflectors.

Input control linkage connected to the servo valve control arm of the PC cylinders positions the valve slider to direct pressure to the actuating pistons. The actuating piston extends or retracts the cylinder housing. As the cylinder housing moves, the servo valve control arm repositions the servo valve slider. When the ailerons and spoiler/deflectors position is equal to the demand input, the servo valve slider is again at neutral. Fluid flow is blocked to and from the cylinder until a new control system input is initiated.

The spoiler/deflector on each wing operates with the upward throw of the aileron on that wing. They are located in the left and right-hand wing center sections, forward of the flaps. The spoiler extends upward into the airstream, disrupting the airflow and causing decreased lift on that wing. The deflector extends down into the airstream and scoops airflow over the wing surface aft of the spoiler, preventing airflow separation in that area.

A stop bolt on the spoiler/deflector bell crank limits movement of the spoiler to 60 degrees of deflection. The deflector is mechanically slaved to the spoiler. It can be deflected to a maximum of 30 degrees when the spoiler is at 60 degrees. The spoiler deflectors open only with the upward movement of the ailerons. They are normally closed. The linkage motion lost when the aileron is down is absorbed by the spoiler deflector load-limiting link.

Spoiler Control System

On one model aircraft, spoiler action is provided through the control stick grip, roll command transducer, roll computer, pitch computer, and eight spoiler actuators (one per spoiler). When used to increase the effect of roll-axis control, the spoilers can only be controlled when the wings are swept forward at 57 degrees.

Right or left movement of the control stick grip mechanically transfers to the roll command transducer. The transducer converts the movement to inboard and outboard spoiler roll commands. Because the spoilers are vital for landing, the left and right-wing inboard and No. 1 mid-spoilers are controlled by the roll computer. The spoilers are powered by the combined hydraulic power systems. The left and right outboard

and No. 2 mid-spoilers are controlled by the pitch computer. These spoilers are powered by the mid-outboard spoiler/high lift backup module. This combination provides positive spoiler control if either computer or hydraulic power source malfunctions.

DIRECTIONAL CONTROL SYSTEMS

Directional control systems provide a means of controlling and/or stabilizing the aircraft about its vertical axis. Most Navy aircraft use conventional-type rudder control systems for this purpose.

The rudder control system, shown in figure 16-15, is operated by the rudder pedals in the cockpit. The system is powered hydraulically through the rudder actuator. In the event of hydraulic power failure, the

hydraulic portion of the power system is bypassed. The system is then powered mechanically through control cables and linkage. An aerodynamic irreversible hydraulic system is employed in the rudder system. To accomplish trim, the complete rudder surface is repositioned.

The actuation of the rudder pedals causes the control cables to move a cable sector assembly. The cable sector, through a push-pull tube and linkage, actuates the power mechanism. The rudder actuator deflects the rudder to the left or to the right.

A load-feel bungee is connected to the push-pull tube, and is compressed when the push-pull tube is actuated. When the pedals are released, the compressed bungee returns the system to the neutral

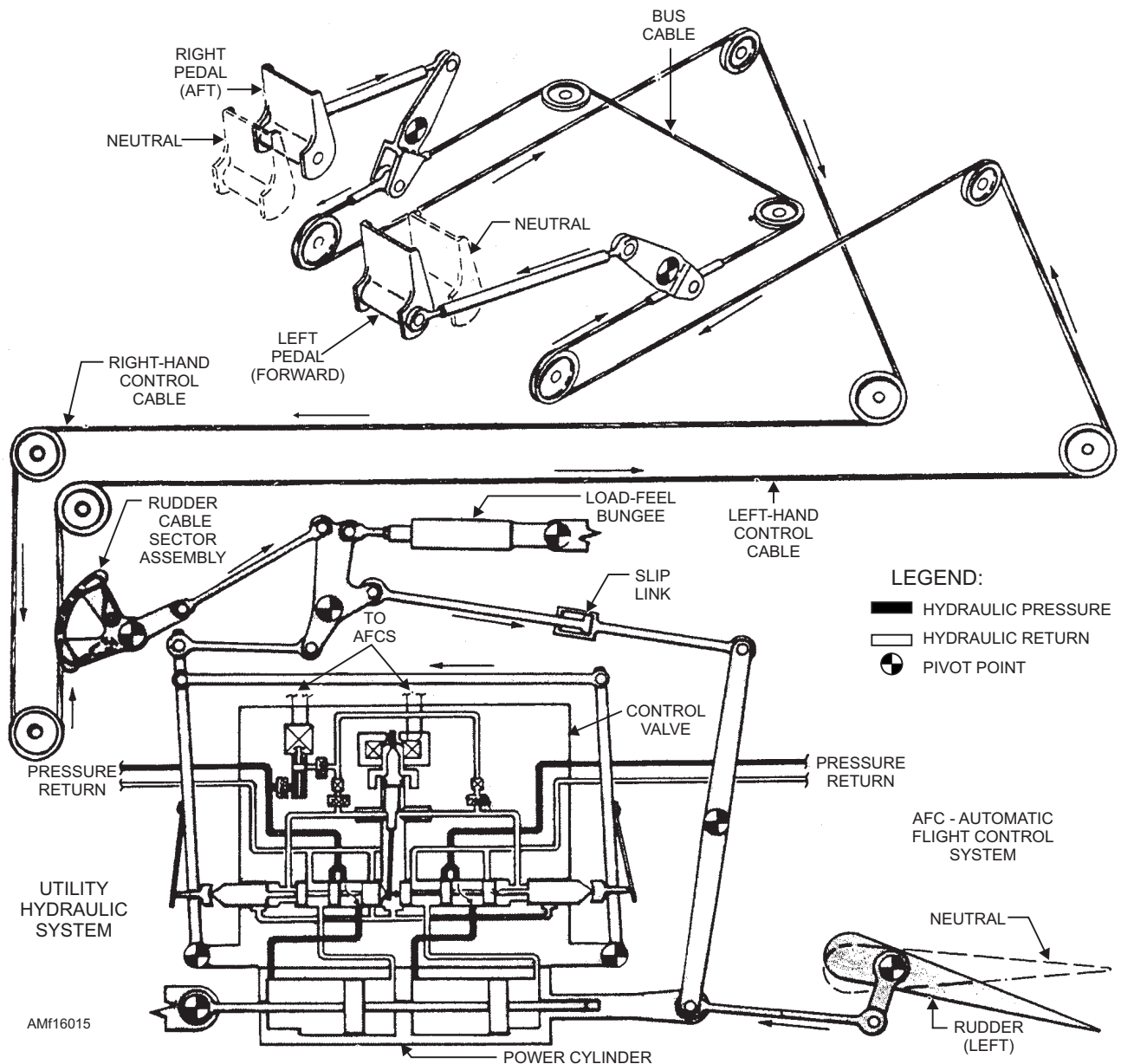

Figure 16-15.—Rudder control system.

position. In the event of hydraulic failure, a slip link allows movement of the control valve linkage to port hydraulic fluid from the actuating cylinder. Then the cylinder can be mechanically driven by pilot input during manual operation. In manual operation, surface travels are reduced by the lost-motion effect of the slip link.

The load-feel bungee is also the connecting link from the rudder trim actuator to the power mechanism. When the trim actuator is operated, the bungee repositions the power mechanism. The power mechanisms deflect the rudder for nose-left and nose-right trim. Figure 16-15 is a functional schematic of the operation of the rudder control system.

The rudder power mechanism is actuated when movement from the cable sector assembly is transmitted through the push-pull tube to the primary control crank. The crank is connected to the load-feel bungee, a slip link to the secondary crank, a link and spring to the pedal position transmitter, and a link to the control valve of the actuator assembly. The actuator assembly consists of an electromechanical dual input control valve, a rudder surface position transmitter, and a power cylinder. When the mechanism linkage is actuated, the control valve directs hydraulic pressure from both the utility hydraulic system and the surface control hydraulic system to the power cylinder. The valve directs the hydraulic pressure to two separate chambers in the cylinder. Each chamber has a separate piston that is mounted on a common shaft. The shaft is connected to a push-pull tube that moves the rudder. The actuator assembly normally operates from both hydraulic systems. If one system should fail, the other supplies sufficient pressure to operate the rudder with some lost hinge movement. In the event both hydraulic systems fail, the slip link will allow movement of the control valve linkage to port hydraulic fluid from the actuating cylinder.

When the automatic flight control system is engaged, the actuator initiates the movement of the rudder system through the electrical impulse received by the control valve from the surface control amplifier. The pedal position transmitter and the rudder surface transmitter function only when the automatic flight control system is engaged.

Rudder pedal movement transfers mechanically to the left and right rudder servo cylinders through the rudder feel assembly, the yaw summing network, and the reversing network. These servo cylinders, normally powered by the flight and combined hydraulic power systems, move the rudders. If both hydraulic systems

fail, the rudder servo cylinders automatically receive hydraulic power from the backup hydraulic system (flight control backup module). The rudder trim switch on the EXT ENVIRONMENT/THROTTLE control panel enables trimming of the aircraft in yaw. Setting the switch to L or R provides a trim-left or trim-right input, respectively, to the rudder trim actuator. The actuator provides rudder movement through the rudder-feel assembly, the yaw summing network, the reversing network, and the rudder servo cylinders.

ELECTRONIC PRIMARY FLIGHT CONTROL SYSTEMS

All electronic flight control servo cylinders are controlled by electrical impulses from computers. The computers compare all data received from the pilot's control stick, airspeed indicator, altimeter, angle of attack, and other sensors. They configure all flight controls for best flight characteristics and performance of the aircraft. An example of the electrical portion that replaces the mechanical linkages system is shown in figure 16-16. Each electric component is duplicated two to four times throughout the system. Provisions are made to detect a failed component or sensor and remove its influence from the system. These multiple redundant paths ensure that a single failure has no effect, and multiple failures have minimum effect on controls.

Q16-4. On small or low-speed aircraft, cockpit flight controls are connected directly to control surfaces by what means?

Q16-5. On high-speed aircraft, what components aid the pilot in moving the flight control surface?

Q16-6. Current specifications call for what type of power source for emergency operation of a primary flight control system?

Q16-7. In an elevator system, what component ports hydraulic pressure to the power cylinder?

Q16-8. With the stabilizer trimmed nose down, what action does the load-feel bungee add on the elevator?

Q16-9. Stabilizer trim deflection on an S-3 aircraft is from how many degrees down to up?

Q16-10. What is the maximum surface deflection of each stabilator on an F/A-18 aircraft?

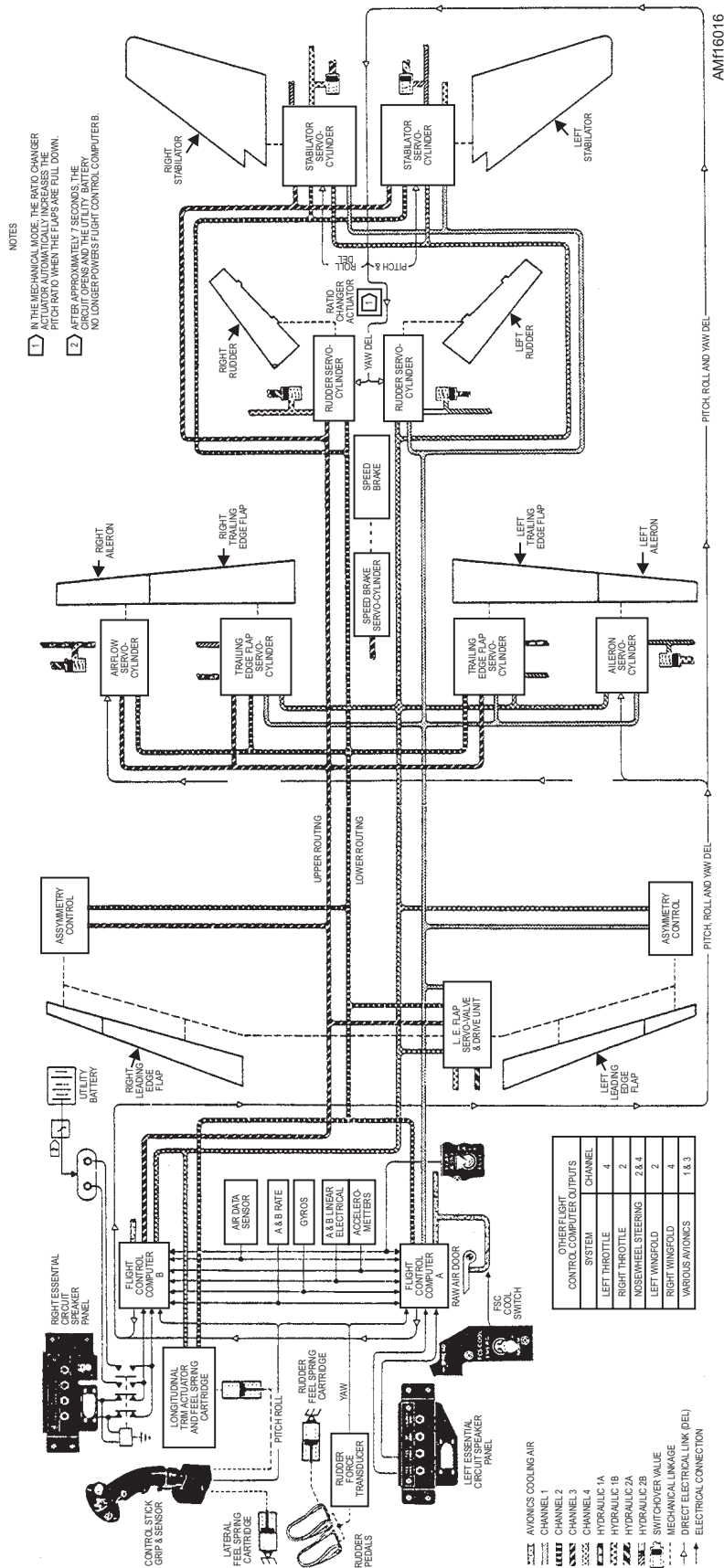

Figure 16-16.—Electronic flight controls.

- Q16-11. Full throw of a pilot's control stick raises the inboard flaperons how far?
- Q16-12. Full throw of the pilot's control stick raises the outboard flaperons how far?
- Q16-13. All four flaperons will automatically pop up approximately how many degrees when the aircraft has weight on wheels and the throttles are retarded?
- Q16-14. What combined flight control system achieves an increased roll rate about the longitudinal axis?
- Q16-15. What causes the spoiler deflectors to open?
- Q16-16. What control system provides a means of controlling an aircraft about its vertical axis?

BACKUP SYSTEM

LEARNING OBJECTIVE: Identify components of the backup system for primary flight controls.

Despite the dual system design requirement for flight control systems, a complete hydraulic system failure is possible. System failure could be a result of component or plumbing failure or as a result of enemy-inflicted damage. The backup flight control system, shown in figure 16-17, provides for an additional measure of flight control safety. The system activates whenever a partial or complete hydraulic system failure occurs.

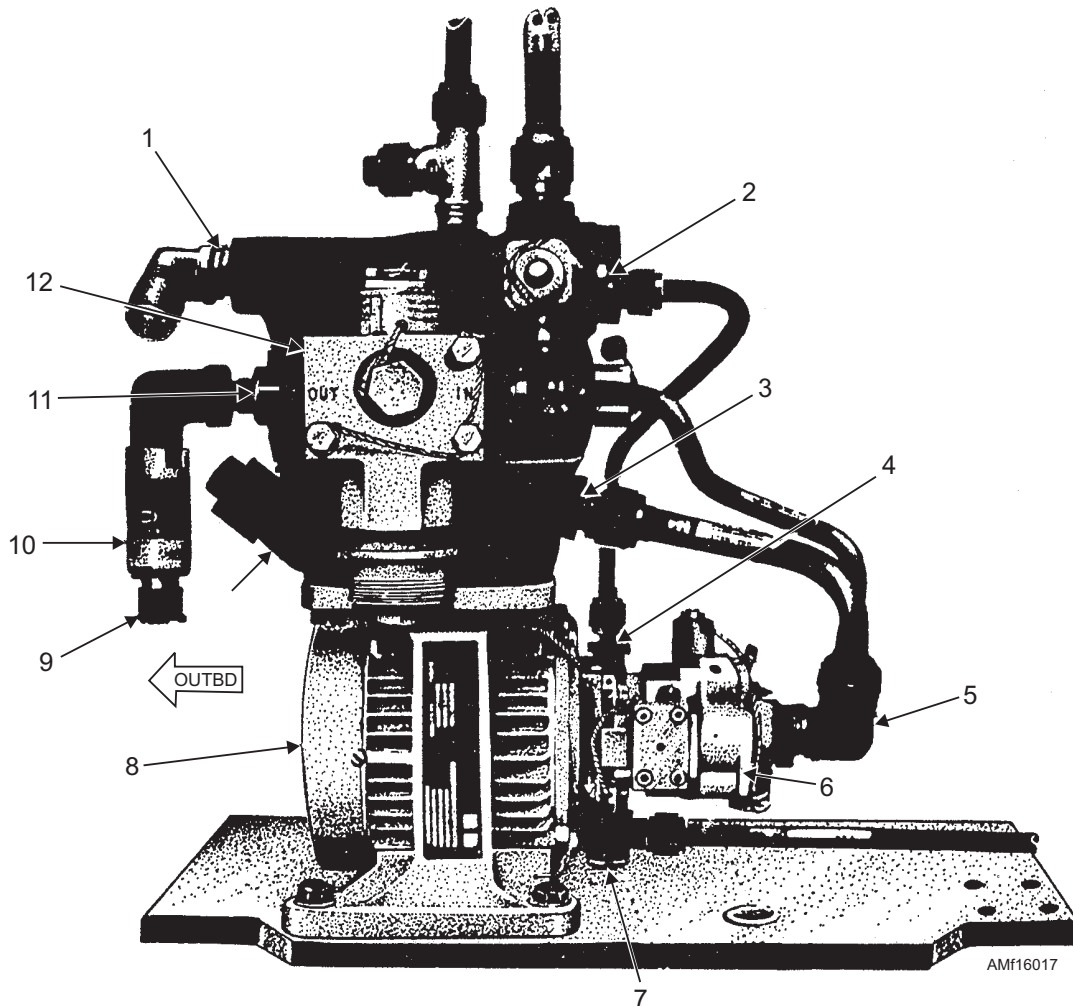

- | | | |
|-------------------------------|--------------------------|------------------------|
| 1. Rudder return port | 6. Pump | 11. Check valve |
| 2. Case drain (reservoir) | 7. Seal drain port | 12. Filter assembly |
| 3. Suction port | 8. Motor | 13. Reservoir assembly |
| 4. Case drain (pump) | 9. Electrical receptacle | |
| 5. Suction and pressure ports | 10. Pressure switch | |

Figure 16-17.—Backup flight control hydraulic system.

COMPONENTS

The complete backup flight control system is mounted on a protective armor plating that measures only 8 by 16 inches and is located close to the rudder and stabilizer power packages. Flight and combined hydraulic system pressure line switches control the operation of this system.

The two switches in the pressure lines to the backup flight system are wired normally closed at zero pressure. The backup pump outlet pressure switch is wired to normally open at zero pressure. The switches actuate at 900 to 1,100 psi on rising pressure and 700 to 900 psi on decreasing pressure. Closing of the combined or flight system pressure switches energizes the backup system motor pump. Closing the outlet pressure switch lights the backup hydraulic system indicator light on the annunciator panel in the cockpit.

When pressure in the flight and/or combined hydraulic system decreases to 700-900 psi, the system is automatically activated. The system isolates a portion of the combined system in the tail of the aircraft by check valves in the pressure lines and a shutoff valve in the return line. When the shutoff valve closes, it stores a full charge of fluid in the backup system reservoir.

The reservoir mounts on top of the motor-pump assembly. It has a capacity of 0.84 quarts. The return system shutoff valve is an integral part of the reservoir end flange inside the reservoir pressurizing spring. The soft-seated, poppet-type shutoff valve is held open when the reservoir is at the full position. When pressure drops and the reservoir piston moves about three-sixteenths of an inch away from the full position, the spring-loaded valve closes and prevents flow from the reservoir. The shutoff valve also acts independently as a relief valve to relieve reservoir pressure above 95 psi.

Return fluid flow from the rudder and stabilizer actuators fills the backup system reservoir. When the reservoir approaches the full position, it mechanically opens a shutoff valve, allowing return flow to go to the combined system reservoir. In normal flight, the 40-psi return system pressure is enough to maintain the backup reservoir piston at the full position. The shutoff valve fully opens against its spring pressure.

If return system pressure drops below the reservoir pressurizing spring pressure of 15 psi, the reservoir piston moves and displaces fluid through the shutoff valve. As the piston moves, the shutoff valve closes

fully in three-sixteenths of an inch of piston movement.

The shutoff valve may open momentarily during backup system operation to discharge excess fluid volume. This action may be a result of unequal stabilizer in-and-out stroke volume or thermal expansion of the fluid. The shutoff valve also opens when the flow rate exceeds the flow capacity of the backup pump. The latter condition could occur when the flight system is operating normally and high rate inputs are applied to the actuators.

OPERATION

Pressure line isolation is accomplished by the use of check valves. To prevent backup system leakage to a failed combined system, a soft-seat check valve is installed upstream of the standard metal-seat check valve. These valves are found in the combined system pressure line.

A three-position backup system hydraulic test switch is located in the cockpit. The central spring-loaded OFF position provides automatic function in flight. The momentary hold positions, COMBINED and FLIGHT, are for a ground test of the system when the aircraft is on external electrical power. Selection of either position will energize the motor pump when aircraft pressure is less than 700 to 900 psi.

A cartridge-type filter element housed within the reservoir head and a pressure line filter protects the system from contamination. Since the backup motor pump is energized when either or both primary systems fail, the following three operational conditions can exist:

1. With the backup and flight systems operating, normal flight control is available. The backup system performs as an isolated system with the return shutoff valve closed. The variable displacement backup motor pump has a maximum rated output of 3 gpm at 1,000-psi output pressure to zero gpm at cutoff pressure (3,000-3,200 psi). The pump cannot match the high rate capacity of the flight system. Backup motor pump pressure will drop to zero when demand exceeds 3 gpm. Zero pressure causes the cockpit indicator light to go out. When pressure increases to 900-1,000 psi, the light will come on again, indicating backup system operation.

2. With the backup system and combined system operating, normal flight control is available. The backup system is not isolated, as normal combined

system pressure exists within pressure and return lines. The return shutoff valve remains open. Combined system pumps maintain high pressure at the rudder and stabilizer actuators. Flow demand on the backup pump is not excessive at high rates. The cockpit indicator light should remain on, indicating backup system operation.

3. When the flight and combined systems fail, the backup flight control system performs as an isolated system. Surface rates available at the rudder and stabilizers are reduced by the limited output of the backup pump. There is no flaperon actuator control. The cockpit indicator will flicker out if the pilot applies inputs to the controls that exceed the capacity of the pump. The cockpit RUDDER THROW light will also be illuminated, indicating that approximately 33 percent of normal rudder throw is available.

Q16-17. When is a backup flight control system activated?

Q16-18. At what pressure does the backup hydraulic system get activated?

Q16-19. When does the backup flight control system perform as an isolated system?

PRIMARY FLIGHT CONTROL SYSTEM MAINTENANCE

LEARNING OBJECTIVE: Recognize the procedures for primary flight control system maintenance to include trouble analysis, rigging/alignment, and operational checks.

Maintenance of primary flight control systems consist of periodic maintenance, trouble analysis, removal and replacement of flight control components, rigging and adjustment of the flight controls, and operational and alignment checks of the primary flight control system. Most primary flight control component maintenance is limited to removal and replacement of the component. Check the applicable MIM for proper repair procedures.

MALFUNCTION OF PRIMARY FLIGHT CONTROLS

There have been many cases reported in which pilots have found flight controls jammed while the aircraft was on the ground. Because the controls were freed by excessive pressure before an inspection could be made, the causes for the jammed condition could not be found. No positive corrective action was taken before the aircraft were released for flight. In some

cases, accidents occurred on such aircraft shortly thereafter.

When an aircraft experiences a control discrepancy during flight, a thorough investigation should be conducted immediately. In cases where aircraft have safely returned from a flight during which a control discrepancy was experienced, a thorough investigation is necessary. This investigation must be made before further flight. All parts of the affected control system should be inspected for proper rigging, clearances, and potential causes for interferences. All sealed units that are suspect must be replaced. Primary cause factors that should not be overlooked include maneuvers that have exceeded the operational design of the control systems. Hydraulic system contamination, corrosion and/or distorted or disconnected linkage may have caused the problem. Inadequate lubrication and external contamination in the form of preservative compounds, such as grease combined with dirt and dust, may have caused the problem. An increasing number of flight control system malfunctions are related to system contamination, and this ever-important aspect of hydraulic system maintenance should be given the attention it deserves. Checking of system filters and contamination inspection of suspected systems are within the capability of organizational activities. If a system is found to be contaminated, the source of contamination must be eliminated and the system cleaned by recycling or flushing in accordance with instructions provided in the appropriate MIM. Contaminated components must be replaced as necessary to restore proper system operation.

Disposition instructions for removed hydraulic components vary with the production status of the aircraft model. Diligent care must be taken to retain the component in the *as-is* condition, with no change in adjustment, disassembly, or cleaning. If the component has slides or pistons that are jammed, no attempt to free them should be made.

The aircraft must not be released for further flight until the cause has been determined and corrected. If it is not readily apparent why the component malfunctioned, you should submit a Hazardous Material Report/Engineering Investigation request. If the discrepancy cannot be duplicated or cause determined, an appropriate entry must be made in the Miscellaneous History section of the aircraft logbook.

TROUBLE ANALYSIS

Trouble analysis of the flight control systems requires the same systematic approach as any other hydraulic system. In many instances, malfunctions are written off with incorrect corrective actions on the maintenance action form (MAF). Corrective action labeled “Could Not Duplicate” or “Replaced Suspected Component” often results in a repeat discrepancy or loss of the aircraft. You should be very thorough in determining the cause of a malfunction.

Trouble analysis of the flight controls will require complete cooperation with other work centers that are involved in the operational checkouts. Most flight control systems have electrical input, as well as mechanical input from autopilot, automatic flight control systems, or stabilizing augmentation systems. Inputs occasionally cause erratic and/or misleading aircraft flight characteristics. Flight characteristics can be misinterpreted, and the resultant write-up in the aircraft discrepancy portion of the aircraft flight record book may be vague or misleading. To gain further insight regarding the vague discrepancy, the maintenance crew should question the pilot who experienced the malfunction.

Isolating the mechanical and hydraulic portion of the flight control system from systems that provide automatic input will serve to pinpoint the actual problem area. The MIM provides troubleshooting/trouble analysis aids and appropriate schematics. The MIM allows for the systematic checking out of the system and associated components. In some MIMs these aids are general in nature and limited to the more common causes of failure. Several MIMs combine the operational checkout procedures with trouble analysis aids. Steps of the checkout procedures are performed in rigid sequence, and any discrepancy must be corrected before proceeding to the next step.

A thorough knowledge of the system involved and consistent use of the mechanical and hydraulic schematics will expedite the trouble analysis process. Excessive time required for troubleshooting should be documented on a separate VIDS/MAF. This will separate the actual repair time from troubleshooting time. Separate VIDS/MAFs provide more accurate input information to the Maintenance Data Reporting System.

When the malfunction has been determined and corrected, the complete system should be operationally tested. Testing should occur in all modes

of operation to verify system integrity. Quality assurance inspection during repair progression, testing, and of the end product is a must. When prescribed in the applicable periodic maintenance information cards, test flight requirements are mandatory. The test flight pilot is briefed by a qualified quality assurance representative regarding the nature of the discrepancy and corrective action taken.

POWER ACTUATOR MAINTENANCE

Maintenance of primary flight control surface power actuators is generally beyond the capability of organizational maintenance-level activities. Removal of hydraulic components and associated linkages on the power actuators will destroy critical adjustments. Readjustment requires special tooling, jigs, and other equipment available only at intermediate- or depot-level maintenance facilities. When a power mechanism has been isolated as the cause for flight system malfunction, it is removed. It is forwarded with the accompanying paperwork to the supply activity for disposition.

RIGGING AND OPERATIONAL CHECKS

Procedures for rigging flight control systems vary with each type of aircraft. Applicable MIMs provide a list of tools, special equipment, preparatory considerations, and step-by-step instructions for rigging systems.

On some aircraft, the system rigging divides into a series of sections, such as the control stick, control mechanism, power control actuator, and cables. If only that section of the system has been affected, it may not be necessary to rig the complete system.

Pushrods, bell cranks, and idlers are installed so that end play is eliminated. They should be free to rotate without binding. Cables should be inspected for corrosion, broken strands, and proper tension. Correct cable tension is necessary to obtain proper response of the control surface. Low cable tension may cause sluggishness, free play, and flutter of the control surface. Excessively high cable tension will cause increased system friction and may result in damage to pulleys, bell cranks, or the cable itself.

A variety of fixtures, pins, and blocks are available for performing alignment and rigging checks on flight control systems. Neutralizing (locking the controls and linkage in a predetermined position), as described in the aircraft MIM, is required during the alignment and adjustment of the flight controls.

NOTE: Installation and removal of the fixtures, pins, and blocks should not require excessive force. Slight pressure is permissible because of the system tolerance and temperature effects on the aircraft. Always refer to the MIM for tolerance information.

Figure 16-18 shows the throwboard used to check the travel of a horizontal stabilizer. The throwboard is held in place by two wingnut attachment screws. Before tightening these screws, the throwboard is positioned so that the alignment hole at the zero-degree mark is in line with the alignment screw in the aircraft fuselage.

Control surface throws may be measured in degrees and minutes or inches and fractions. Figure 16-19 provides an example of an aileron throw indication in degrees (°) and minutes (′). The protractor scale is calibrated in 30-minute increments. The indicator reads 3 degrees 30 minutes obtained as follows:

1. Read 3 degrees 30 minutes, as shown on the protractor scale.

2. Since the indication mark does not fall directly on the calibrated mark of the protractor scale, look for the closest alignment of indicator and protractor calibrated marks in the direction of indicator travel. Read the value from the 0-minute mark on the indicator to the closest alignment, which, in this example, is 10 minutes.

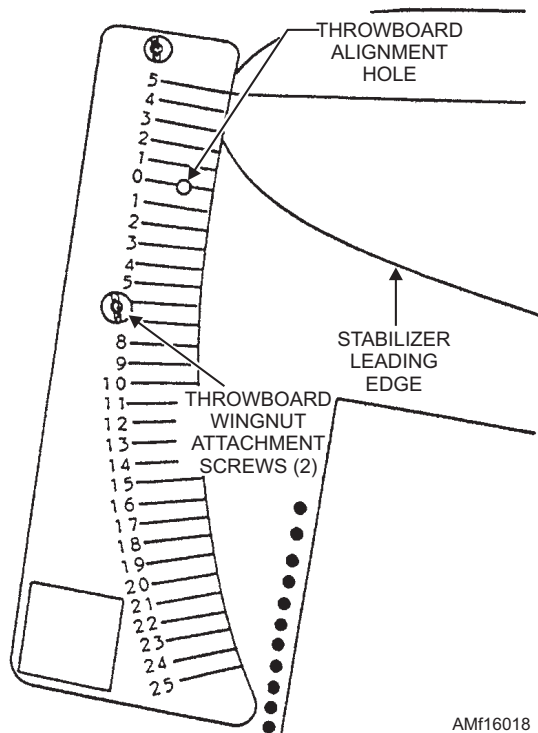

Figure 16-18.—Stabilizer throwboard installation.

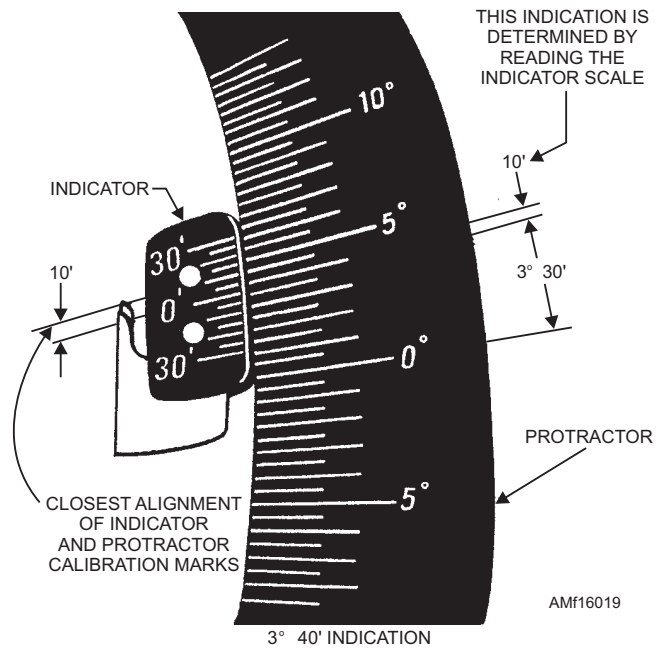

Figure 16-19.—Aileron throw protractor indications.

3. Add 3 degrees 30 minutes and 10 minutes to get the true indication of 3 degrees 40 minutes up travel.

Each mode of operation that was affected by alignment or malfunction and subsequent repair action must be operationally checked, and the success of the checkouts verified by a qualified quality assurance representative. All maintenance, including alignment, adjustment, operational testing, and component replacement, must be in accordance with the instructions provided in the applicable MIM.

- Q16-20. What must be done to a flight control hydraulic component when it is found to be contaminated?*
- Q16-21. When an aircraft has a discrepancy with the flight controls system, when is the aircraft released for further flights?*
- Q16-22. What corrective action often results in a repeat discrepancy or loss of aircraft?*
- Q16-23. Maintenance of the primary flight control power actuator is generally beyond the capability of what maintenance level?*
- Q16-24. What will ensure proper response of a flight control surface?*

CONTROL SYSTEMS MAINTENANCE

LEARNING OBJECTIVE: Recognize the maintenance procedures for cable and push-pull rod (rigid control) systems.

Cable and rigid control systems maintenance includes inspection to discover actual and potential defects, servicing with lubricants, and correction of reported malfunctions and defects. Malfunctions that occur in control systems include frayed and loosened bearings, unnatural tightness (binding), and broken or damaged components.

CABLE CONTROL SYSTEM

Cables have many advantages. They will not sever readily under sudden strains. Cables are stronger than steel rods or tubing of the same size. They flex without setting (permanent deformation) and can be led easily around obstacles by using pulleys. Cables can be installed over long distances (such as in large aircraft) without a great degree of sagging or bending. Vibration will not cause them to harden, crystallize, or break, as may be the case with push-pull control rods. Because of the great number of wires used in cables, cable failure is never abrupt, but is progressive over periods of extended use. When used for the manipulation of a unit in a control system, they are usually worked in pairs—one cable to move the unit in one direction, the other to move it in the opposite direction. Weight is saved in spite of a second cable because the push-pull rod needed to cause a similar movement in a unit would have to be quite thick and heavy (comparatively speaking). Since cables are used in pairs and are stretched taut, very little play is present in system controls, and no lost motion exists between the actuating device and the unit. Consequently, cable-controlled units respond quickly and accurately to cockpit control movement. In some simple cable systems, only one cable is used, and a spring provides the return action.

Cable Maintenance

Cable control systems require more maintenance than rigid linkage systems; therefore, they must be inspected more thoroughly. Cables must be kept clean and inspected periodically for broken wires, corrosion, kinking, and excessive wear.

INSPECTION.—Broken wires are most apt to occur in lengths of cable that pass over pulleys or through fairleads. On certain periodic inspections, cables are checked for broken wires by passing a cloth along the length of the cable. Where the cloth snags the cable is an indication of one or more broken wires.

WARNING

Your bare hands should NEVER be used to check for broken wires. Using your bare hands to check for broken wires could result in personal injury.

Tests have proven that control cables may have broken wires and still be capable of carrying their designated load. However, any 7 x 19 cable that shows more than six broken wires in any 1-inch length, or any 7 x 7 cable that shows more than three broken wires in any 1-inch length, must be replaced. A maximum of three broken wires per inch is allowable in the length of cables passing over pulleys, drums, or through fairleads. Figure 16-20 shows how to determine if a cable is serviceable.

Corrosion, kinking, and excessive wear should be given particular attention during cable inspection. If a cable is found to be kinked or badly worn, it should be replaced, even though the number of broken wires is less than that specified for replacement. If the surface of the cable is corroded, relieve the tension on the cable and carefully untwist it to visually inspect the interior. Any corrosion on the interior strands of the cable constitutes failure, and the cable must be replaced. If no internal corrosion is detected, remove loose, external corrosion with a clean, dry rag or fiber brush and apply the specified preservative compound.

NOTE: Do not use metal wool or solvents to clean installed cable. Metal wool will embed tiny dissimilar metal particles and create further corrosion problems. The use of solvents will remove the internal cable lubricant and allow the cable strands to abrade and further corrode.

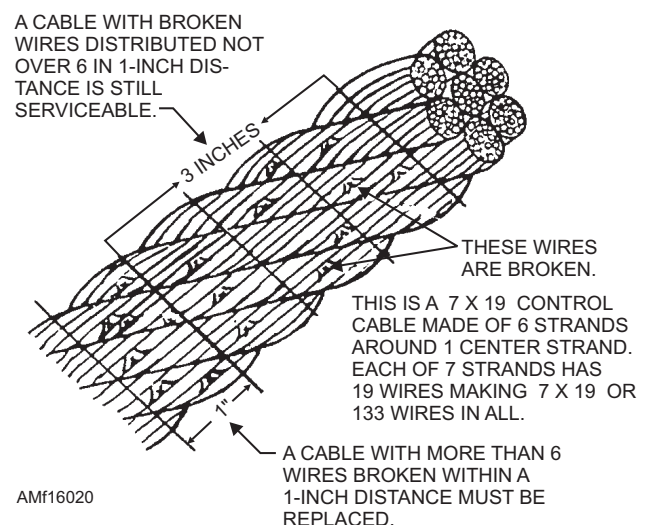

Figure 16-20.—Determining serviceable cable.

When a cable is found to be unserviceable and a spare cable is not available, an exact duplicate of the damaged cable may be prepared. This will involve cutting a length of cable to the proper length, attaching the necessary end fittings, and testing the assembly.

To determine the proper length to which the new cable will be cut, you should first determine the overall length of the finished cable assembly. This may be accomplished by measuring the old cable assembly or by reading the measurements provided in the MIM for the aircraft concerned.

REPLACEMENT.—Replacing cables in the aircraft, especially those routed through inaccessible spaces, can be difficult. One method is to secure a snaking line to the cable to be replaced, remove the pulleys from the brackets, and pull out the old cable while pulling the snaking line into the cable system run at the same time. Attach the new cable assembly to the snaking line, and pull the snaking line out to pull the new assembly into place. Replace the pulleys and attach the new cable in the system.

Quick Disconnects

Quick disconnects are used in cable systems that may require frequent disconnecting. One type of quick disconnect is made with steel balls swaged to the ends of the cable, slipped into a slotted bar, and secured with spring-loaded sleeves on each end of the bar. Figure 16-21 shows the procedures for disconnecting and connecting this type of quick-disconnect fitting.

RIGID CONTROL SYSTEMS

Rigid control systems transfer useful movement through a system of push-pull rods, bell cranks, walking beams, idler arms, and bungees. The simplest rigid control system may consist of push-pull rods and bell cranks only.

Push-pull Rods

Push-pull rods are rigid tubes equipped with eye fittings at each end or with a clevis fitting at one end and an eye fitting at the other. The eyes contain a pressed-in bearing. The rods are generally hollow and neck down to a smaller diameter at each end where the fittings are attached. One or both of the fittings are screwed into the necked portion of the rod, and are held in place by locknuts. When only one stem is adjustable, the stem of the other eye fitting is riveted into the neck at its end of the rod. A hole is drilled into the threaded

neck of a push-pull rod for inspection to ensure that the stem has engaged a safe number of threads. The stem must be visible through the hole. Push-pull rods are generally made in short lengths to prevent bending under compression loads and vibration.

Push-pull rod linkage must be inspected closely for dents, cracks, and bent tubing. Damaged tubes may have to be replaced. End fittings are checked for damage, wear, and security of attachment. Worn or loose fittings must be replaced.

When you are replacing a damaged push-pull tube, the correct length of the new tube may be obtained by loosening the check nut and turning the end fitting in or out, as necessary. When the push-pull tube has been adjusted to its correct length, the check nut must be tightened against the shoulder of the end fitting. Normally, only one end of a push-pull rod is adjustable. The adjustable end has a hole (witness hole) drilled in the rod. The hole is located at the maximum distance the base of the end fitting is allowed to be extended. If the threads of the end fitting can be seen through this hole, the end fitting is within safe limits.

When you are attaching push-pull rods with ball bearing end fittings, the attaching bolt and nut must tightly clamp the inner race of the bearing to the bell crank, idler arm, or other supporting structure. Nuts should be tightened to the torque values listed in the aircraft MIM.

After installing a new push-pull rod in a flight control system, the control surface must be checked for correct travel. Procedures for accomplishing this are described later in this chapter. If the travel is incorrect, the length of the push-pull rod must be readjusted.

Bell Cranks and Walking Beams

Bell cranks and walking beams are levers used in rigid control systems to gain mechanical advantage. They are also used to change the direction of motion in the system when parts of the airframe structure do not permit a straight run. They are often used in push-pull tube systems to decrease the length of the individual tubes, and thus add rigidity to the system.

A bell crank has two arms that form an angle of less than 180 degrees, with a pivot point where the two arms meet. The walking beam is a straight beam with a pivot point in the center. Bell cranks and walking beams are mounted in the structure in much the same way as pulley assemblies. Brackets or the structure itself may be used as the point of attachment for the shaft or bolt

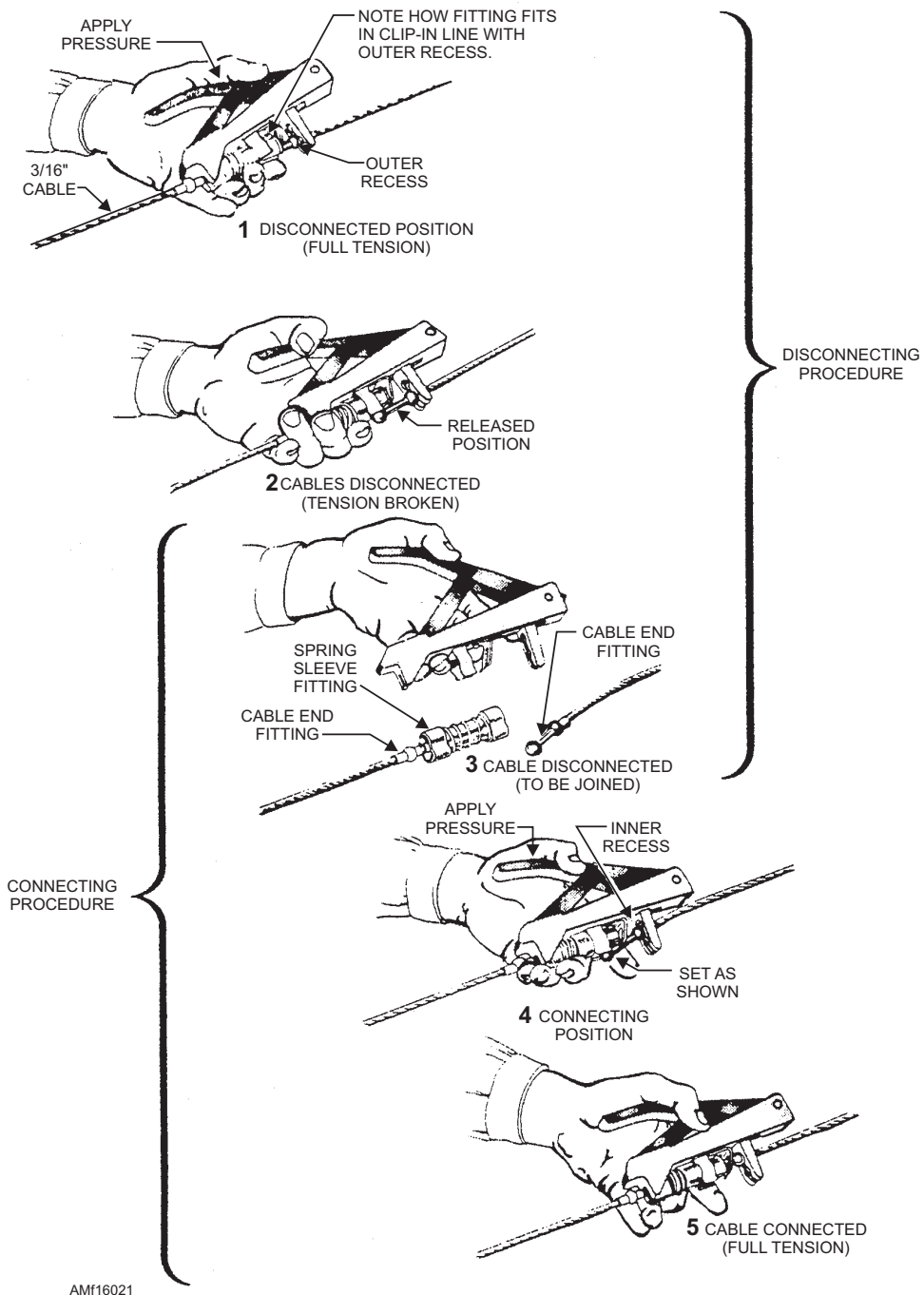

AMF16021

Figure 16-21.—Quick-disconnect procedures.

on which the unit is mounted. Examples of a bell crank and a walking beam are shown in figure 16-22. The two are similar in construction and use. The names bell crank and walking beam are often used interchangeably.

Idler Arms

Idler arms are levers with one end attached to the aircraft structure so it will pivot and the other end attached to push-pull tubes. Idler arms are used to

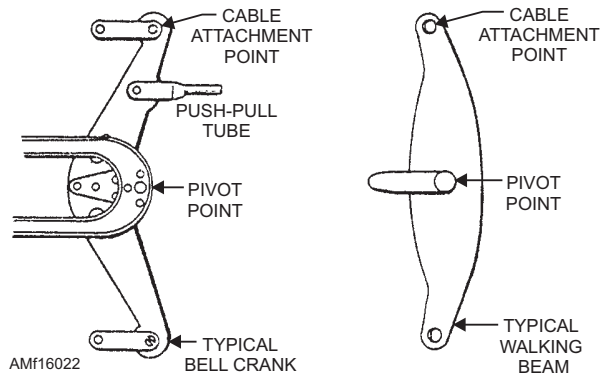

Figure 16-22.—Bell crank and walking beam.

support push-pull tubes and guide them through holes in structural members.

Bungee

Bungees are tension devices used in some rigid systems that are subject to a degree of shock or overloading. They are similar to push-pull rods, and perform essentially the same function except that one of the fittings is spring-loaded in one or both directions. That is, a load may press so hard (compression) against the fittings that the bungee spring will yield and take up the load. This protects the rest of the rigid system against damage. The internal spring may also be mounted to resist tension rather than compression. An internal double-spring arrangement will result in a bungee that protects against both overtension and overcompression.

TROUBLESHOOTING

When the cause and remedy for a reported malfunction in a control system are not immediately obvious to you, it may be necessary to troubleshoot the system. Most aircraft MIMs provide troubleshooting charts that list some of the more common malfunctions in a system. Each discrepancy is accompanied by one or more probable causes, and a remedy is prescribed for each cause. The troubleshooting charts are organized in a definite sequence under each possible trouble, according to the probability of failure and ease of investigation. To obtain maximum value from these charts, they should be used systematically according to the aircraft manufacturer's recommendations.

Since most aircraft use some form of electrical control or hydraulic boost in their flight control systems, maintenance of these systems must include the related electrical circuits and hydraulic systems. Although an AE or AM is generally called upon to locate the correct electrical or hydraulic troubles respectively, you should be able to check circuits for loose connections, perform continuity checks, and perform minor troubleshooting of the hydraulic system.

RIGGING AND ADJUSTING

The purpose of rigging and adjusting a primary flight control system is to ensure neutral alignment of all connecting components and to regulate and limit the surface deflection in both directions.

Special Tools

Each aircraft has a set of special tools for flight control maintenance that may include rigging fixtures, pins, blocks, throwboards and protractors. Other common equipment, such as micrometers, pressure gauges, push-pull gauges, feeler gauges, tensiometers, and calipers may also be required. These are usually maintained in the toolroom and checked out when needed.

TENSIOMETER.—The tensiometer is an instrument used in checking cable tension. Tension is the amount of pulling force applied to the cable. The amount of tension applied in a cable linkage system is controlled by turnbuckles in the system.

A tensiometer is a precision cable tension measuring device, but it has limitations and can be awkward to use. It is inaccurate for cable tension under 30 pounds. When you take tension measurements, the instrument must not be pressed against any part of the aircraft, it can't be pushed or pulled against the cable, and the cable must not be pressed against fairleads or any part of the aircraft. Any one of these actions may lead to inaccurate measurements. A major advantage of cable linkage is its minimal space requirement and the ease in which it can be routed around, through, and behind aircraft structures and components. This can make access difficult and the tensiometer awkward or difficult to use. Adequate clearance for the tensiometer is necessary. All tensiometers must be certified by a calibration laboratory for accuracy at least once a month.

One type of tensiometer is shown in figure 16-23. This instrument works on the principle of measuring the amount of force required to deflect a cable a certain distance at right angles to its axis. The cable to be tested is placed under the two blocks on the instrument, and the lever assembly on the side of the instrument is pulled down. Movement of this lever pushes up on the center block, called a "riser." The riser pushes the cable at right angles to the two clamping points. The force required to do this is indicated by a pointer on the dial. Different risers are used with different size cables. Each riser carries an identifying number, and is easily inserted in the instrument.

Each tensiometer is supplied with a calibration table to convert the dial readings into pounds. One of these calibration tables is shown in figure 16-23. For example, if the pointer on the dial indicates 48 with a No. 2 riser and a 3/16-inch diameter cable, the actual tension on the cable is 100 pounds. With this particular

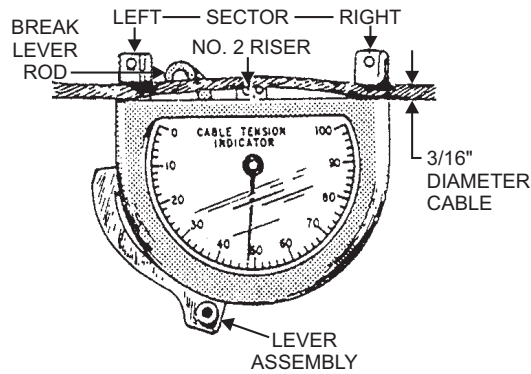

NO. 1			RISER	NO. 2		NO. 3	
DIA	1/16	3/32	TENSION LBS.	5/32	3/16	7/32	1/4
	14	15	30	14	20		
	18	22	40	18	25		
	23	27	50	22	29		
	27	32	60	26	33		
	31	37	70	29	37		
	35	41	80	32	41		
	39	45	90	35	45		
	43	49	100	38	48		
	46	53	110	41	52		
	49	57	120	44	55		
	53	61	130	47	58		
	56	65	140	49	61		
	59	68	150	51	64		
	62	71	160	54	67		
	65	74	170	56	70		
	68	77	180	58	72		
	70	80	190	60	74		
	72	83	200	62	76		
			220	66	81		
			240	70	85		
			260	74	89		
			280	78	93		
			300	80	97		
TYPED FIGURES ARE INSTRUMENT SCALE READING CORRESPONDING TO TENSION							
INSTRUMENT NO. 6659 MODEL 401-1C-2							

AMF16023

Figure 16-23.—Cable tensiometer and chart.

instrument, the No. 1 riser is used with 1/16-, 3/32-, and 1/8-inch diameter cables.

CAUTION

The calibration table applies to the particular instrument only, and cannot be used with any other. For this reason, the calibration table is secured inside the cover of the box in which the instrument is kept. The chart is serialized with the same serial number as the instrument. Using the calibration table from another instrument will result in inaccurate reading.

During the adjustment of turnbuckles, the calibration table must be used to obtain the desired tension in a cable. For example, to obtain a tension of 110 pounds in a 3/16-inch diameter cable, the No. 2 riser is inserted in the instrument and the number opposite 110 pounds is read from the calibration table. In this case, the number is 52. The turnbuckle is then adjusted until the pointer indicates 52 on the dial.

NOTE: Tensiometer readings should not be taken within 6 inches of any turnbuckle, end fitting, or quick disconnect.

In some cases, the position of the tensiometer on the cable may be such that the face of the dial cannot be seen by the operator. In such cases, after the lever has been set and the pointer moved on the dial, the brake-lever rod on the top of the instrument is moved to the closed position. This locks the pointer in place. Then, the lever assembly is released and the instrument removed from the cable with the pointer locked in position. After the reading has been noted, the brake-lever rod is moved to the open position, and the pointer will return to zero.

The tensiometer, like any other measuring instrument, is a delicate piece of equipment and should be handled carefully. Tensiometers should never be stored in a toolbox.

Temperature changes must be considered in cable-type systems since this will affect cable tensions.

When a temperature is encountered that is lower than that at which the aircraft was rigged, the cables become slack because the aircraft structure contracts more than the cables. When temperatures higher than that at which the aircraft was rigged are encountered, the aircraft structure expands more than the cables and tension is increased.

The cables in any cable linkage system are rigged according to a temperature chart that is contained in the applicable maintenance instructions manual. This chart will give the proper tensions for the various temperature changes above and below the temperature at which the system was rigged.

RIG PINS.—Rig pins are used in rigging control systems. Figure 16-24 shows a rigging pin kit used on one of the Navy's aircraft. As you can see, rig pins may come in various sizes and shapes and may be designed for one or many installations. You should refer to the specific maintenance instructions manual for use and selection of rig pins.

THROWBOARDS.—Throwboards are special equipment used on specific aircraft for accurate measurement of control surface travel. See figure 16-25. Each throwboard has a protractor scale that indicates a range of travel in degrees. Zero degrees normally indicates the neutral position of the control surface. When the throwboard is mounted and the control column or stick is in neutral, the trailing edge of the control surface should be aligned to zero. As the

control column or stick is moved to its extreme limits, you can read the corresponding degree indication on the throwboard. If the travel of the control surface is out of limits, you should adjust cables, push-pull rods, and control limit stops to obtain the correct control surface travel. When you are inspecting and rigging control surfaces, the specific maintenance instructions manual should be consulted.

Cable and Rigid Control System Rigging

In the elevator system shown in figure 16-26, rigging begins at the aft sector. The aircraft manufacturer has determined the position of the aft sector when it is in the neutral position. A rig pin hole has been furnished in the sector and a mating hole in the adjoining structure. See the three rig pins in figure 16-26. With the rig pin inserted in the aft sector and in the aircraft structure, the sector is held firmly in the neutral position. With the sector in this position, the push-pull tube connecting the sector with the elevator fitting assembly is adjusted to position the elevators to the neutral position. The neutral position is determined by using the elevator rigging fixture shown in figure 16-27. The curved section of the rigging fixture is graduated in degrees on either side of the neutral (zero degree) position that is about midway on the curved part of the fixture.

The rigging fixture is fastened securely to the aircraft at the indicated points of attachment. When

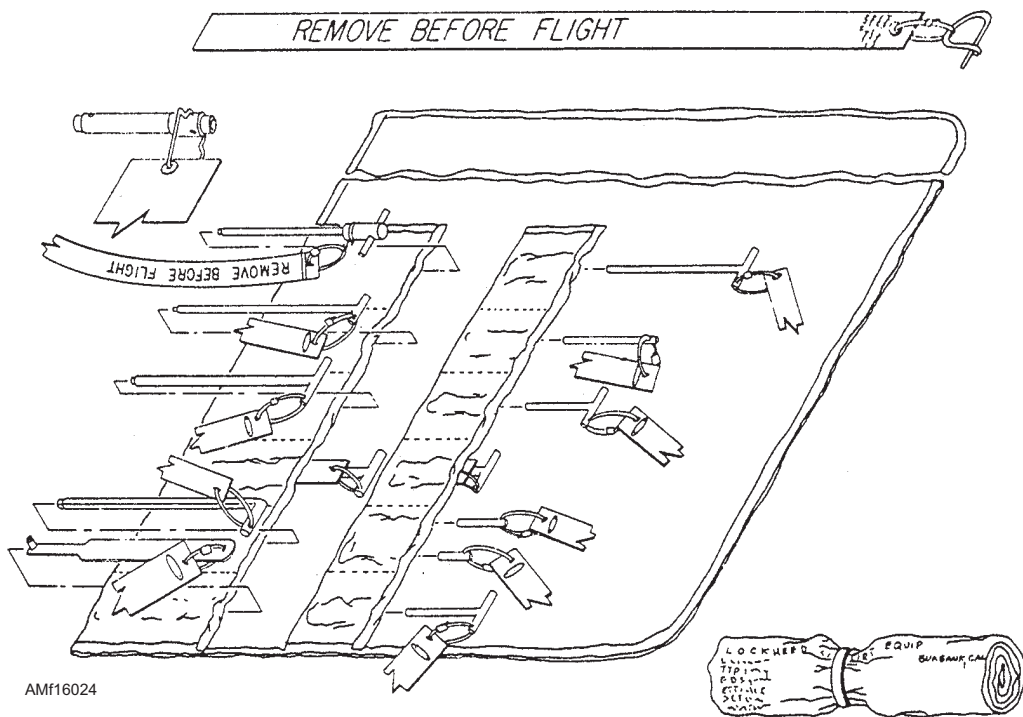
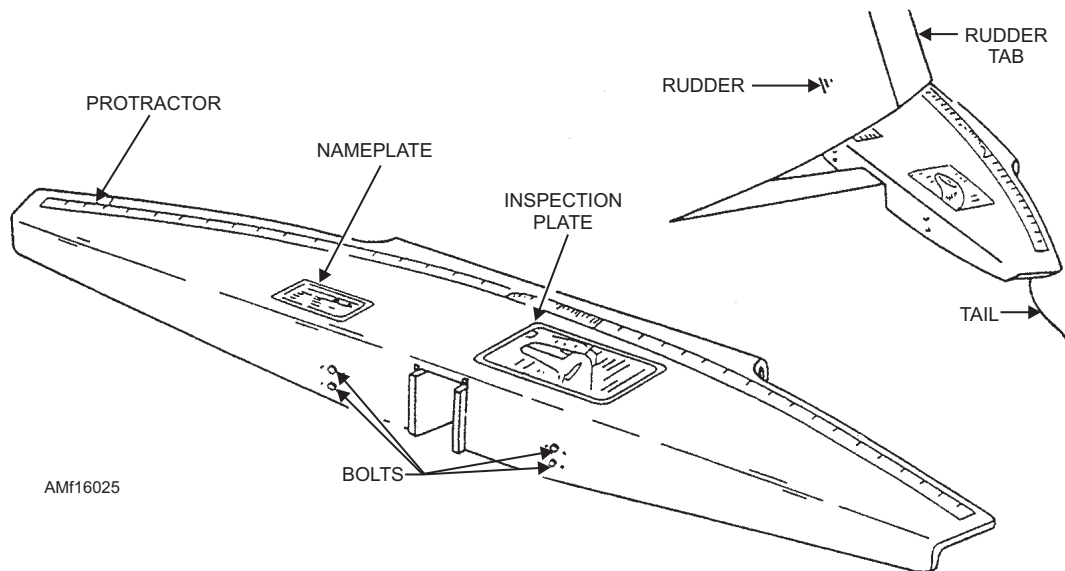
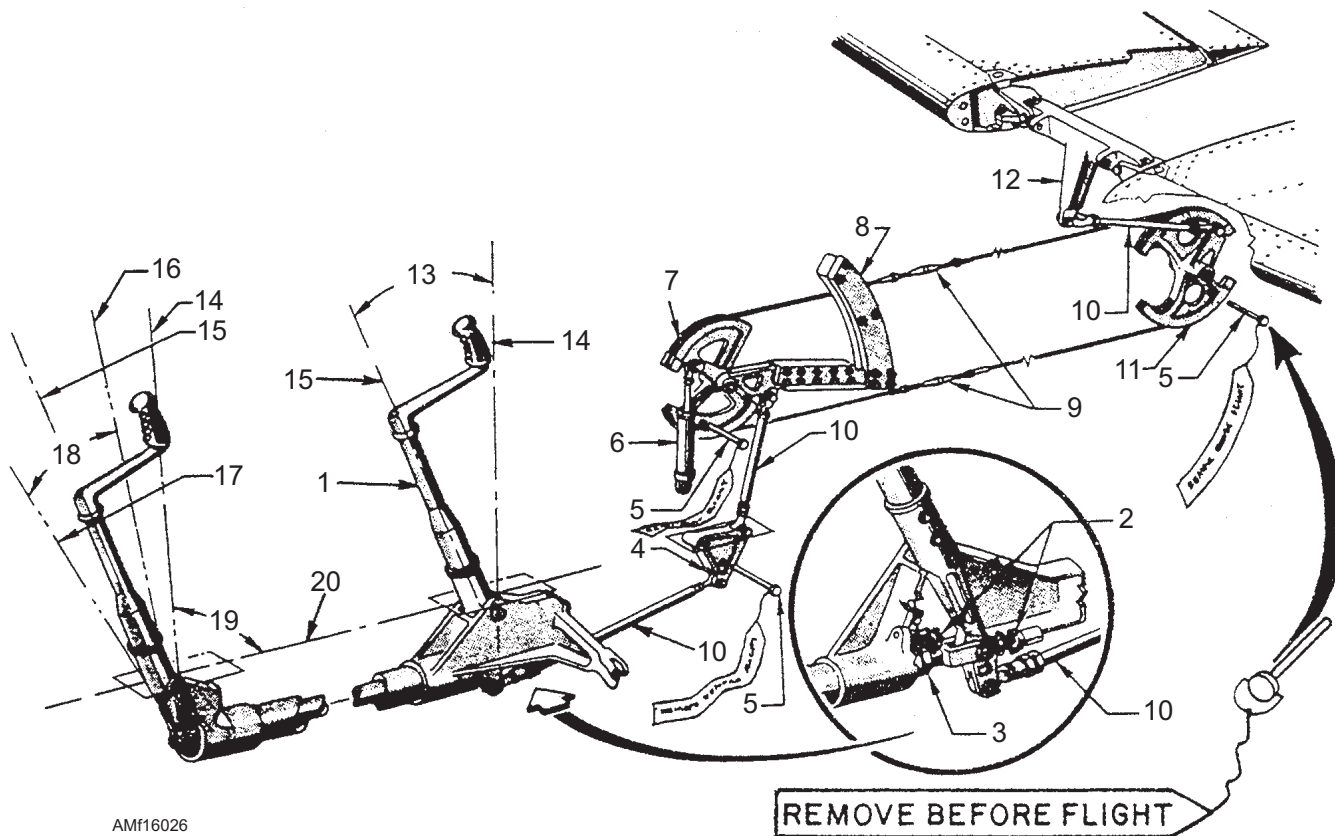

Figure 16-24.—Rigging pin set.



AMf16025

Figure 16-25.—Typical throwboard used for rigging rudder and rudder tab controls.



AMf16026

- | | | |
|------------------------------|-------------------------------|---|
| 1. Aft control stick | 8. Bobweight | 15. Center line-stick neutral |
| 2. Stop bolts | 9. Turnbuckles | 16. Stick throw limit-UP elevator |
| 3. Push-pull tube adjustment | 10. Push-pull tubes | 17. Stick throw limit-DOWN elevator |
| 4. Bell crank | 11. Aft sector | 18. Stick throw range-elevator control |
| 5. Rig pins (3 places) | 12. Elevator fitting assembly | 19. Locating angle-vertical reference line |
| 6. Bungee | 13. Rigging dimension | 20. Longitudinal reference line (cockpit floor) |
| 7. Forward sector | 14. Vertical references line | |

Figure 16-26.—Typical elevator flight control system.

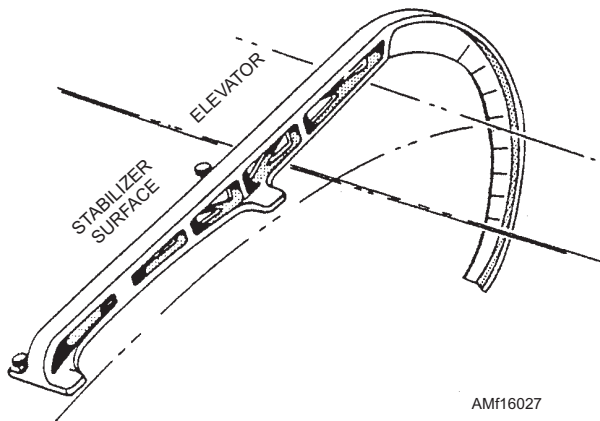

Figure 16-27.—Elevator rigging fixture.

properly mounted, the index marks (graduations) on the curved section align with the elevators and indicate the position, in degrees, of the elevators. If, with the aft sector rig pin in place, the elevators are not in neutral (for example, 5 degrees above the neutral mark), lengthening the push-pull rod end will push the elevator fitting assembly forward, and thereby lower the elevators. If the elevators are too low, then shortening the rod will bring them up as required.

The next step is the adjusting and tightening of the pair of cables in the system. This is accomplished by tightening the turnbuckles on each cable evenly until the required tension is obtained. During cable tightening, the rig pin is retained in the aft sector, leaving the forward sector free to turn. Therefore, when the necessary tension is recorded on one cable, that is also the tension on the other cable. To ensure that the cables were tightened evenly, check the forward sector rig pin hole to see if the rig pin can be inserted through the sector and into the structure. If this is not possible, then the cables must be adjusted by loosening one and tightening the other. This will maintain the correct tension on the cables, and, at the same time, rotate the forward sector to the neutral position. The cable section is properly rigged when it is possible to insert and remove the forward sector rig pin easily with the aft sector pin installed and the cables tightened to the prescribed tension.

The push-pull rod connecting the forward sector and the bell crank is adjusted to the correct length by installing a rig pin in the bell crank. Then, the rod adjustable eye is turned in or out until the rod can be installed between the sector and bell crank without binding. At this point three rig pins are in place, and should remain in place until the control sticks are rigged to neutral.

When you are positioning the control sticks to neutral, the rear stick must be adjusted first.

Remember, we are working forward from the elevator surface. The push-pull rod connecting the bottom of the rear stick with the bell crank must be adjusted until the stick center line is the prescribed number of degrees forward of a vertical reference line. See the vertical reference line (14) and the center line (15) in figure 16-26. The vertical reference line is a position that the center line of the control stick would attain at a 90-degree angle (19) to the cockpit floor (20).

Adjust the length of the push-pull tube between the control sticks to position the front control stick to an angle identical to that of the aft control stick. Then, remove all three rig pins. This completes the rigging and adjusting of the control system to neutral. All that remains is to adjust the stops that limit the fore and aft travel of the control sticks, and rig and adjust the bungee that holds the system in the neutral position.

The stop bolts (2) (fig. 16-26) are located in front and behind the aft control stick. They are installed so that the stick hits the stop bolts at the extreme limits of its travel. The maximum travel of the elevators in each direction is determined by the manufacturer and is controlled by the stop bolts. With the rigging fixture still in place, move the control stick all the way forward, and adjust the stop until the elevator DOWN throw conforms to the MIM. Pull the stick all the way aft, and adjust the aft stop bolt to obtain the correct elevator UP throw. The stop bolts are safety wired in place after this adjustment.

The last item to be adjusted in this control system is the centering bungee. Connect the bungee and adjust its rod end so that with the stick against the stop bolt in the full down elevator position, the bungee is a minimum of 1/32 of an inch from bottoming. After this adjustment, the elevators should be held in neutral (plus or minus the prescribed number of degrees) by bungee action. If the elevators are too high, shorten the bungee rod end. If they are too low, lengthen the bungee. With the bungee properly adjusted, tighten the bungee rod end locknut and safety wire it.

CABLE FABRICATION

Control cables are fabricated mostly of extra flexible, preformed, corrosion-resistant steel. Control cables vary from 1/16 to 3/8 inch in diameter. Cables of 1/8 inch and larger are composed of 7 strands of 19 wires each. Cables 1/16 and 3/32 inch in diameter are composed of 7 strands of 7 wires each.

Cable-Cutting Equipment

Cutting cables may be accomplished by any convenient method except an oxyacetylene cutting torch. The method of cutting usually depends upon the tools and machines available. If a cable tends to unravel, the ends may be sweat soldered or wrapped with a strip of tape prior to cutting.

Small diameter cable may be cut satisfactorily with a pair of heavy-duty diagonal cutters, side cutters, or a pair of wire nippers. Best results are obtained if the cutting jaws are held perpendicular to the cable during the cutting operation. Cables up to $3/32$ of an inch in diameter may be cut in one operation by this method. Larger cables may require two or more cuts. When you cut large diameter cables, use the end of the cutting blade, and cut only a few strands at a time.

The most satisfactory method of cutting cables is with a cable-cutting machine that has special jaws to accommodate various sizes of cable. See figure 16-28. To use this machine, position the cable in the proper diameter groove and hold the cable firmly within 2 inches of the cutting blades. Hold the cable at right angles to the cutting blades and pull the operating handle down sharply.

A cold chisel and a soft metal block may also be used for cutting cables. This method should be used only as a last resort because of the way the cable ends will be frayed.

Swaging Equipment

After the cable is cut, the next step in making up an aircraft cable is attachment of the terminals. Most terminal fittings are SWAGED onto the ends of control system cables. Swaging is essentially a squeezing process in which the cable is inserted into the barrel of the terminal. Then pressure is applied by dies in a swaging machine to compress the barrel of the terminal tightly around the cable. The metal of the inside walls of the barrel is molded and cold flowed by force into the crevices of the cable. Figure 16-29 shows two types of hand-swaging tools. The one in the upper part of the illustration is mechanically operated, while the lower one is pneumatically operated.

When you prepare to swage a terminal, cut the cable to the required length. Be sure to allow for the elongation (increase in length due to stretching) of the fitting that will occur during the swaging process. The amount of elongation will vary with the type and size of fitting used. Therefore, the elongation must be taken into account whenever you make up any cable. The *Structural Hardware Manual*, NAVAIR 01-1A-8, provides elongation data for all types and sizes of fittings.

Make sure that the cable end is cut square and clean and that all strands remain in a compact group, as shown in figure 16-30. Place a drop or two of light lubricating oil on the cable end. Then, insert the end into the terminal to a depth of about 1 inch. Bend the

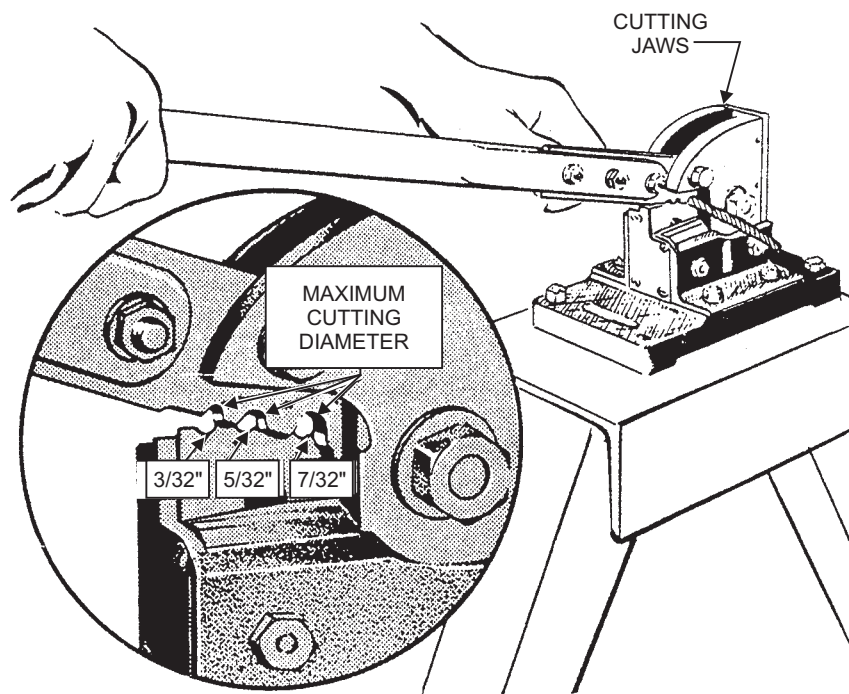

AMf16028

Figure 16-28.—Cable-cutting machine.

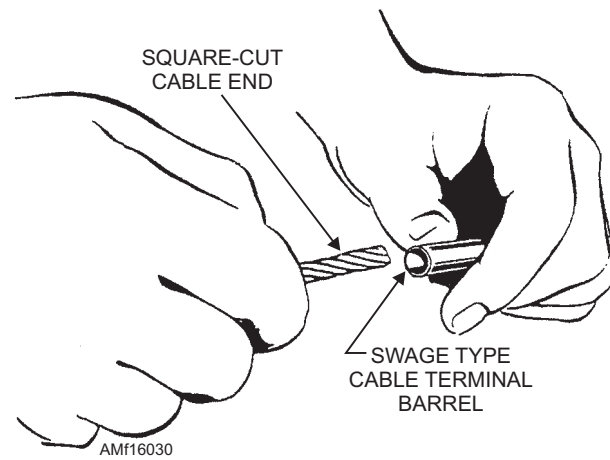
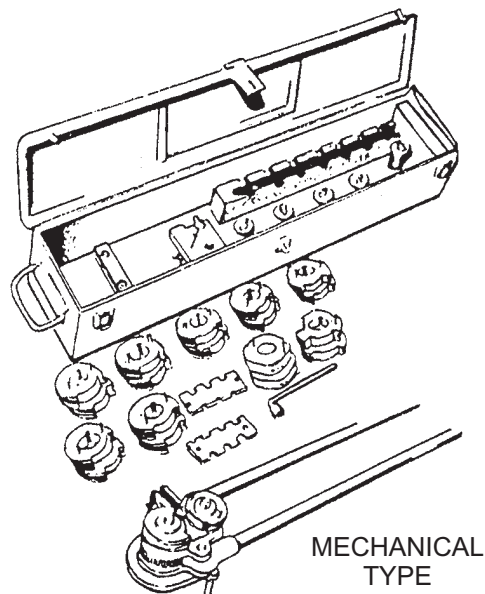

Figure 16-30.—Inserting cable in swage terminal.

Both of the hand-swaging tools shown in figure 16-29 are widely used by naval aircraft maintenance activities. When operating the mechanical swaging tool, you should place the proper size pair of dies on the swaging tool. The terminal is then located in the jaws of the tool, as shown in figure 16-31, and the swaging operation is performed. As the dies rotate, they pull the terminal from right to left. The dies compress the terminal barrel onto the cable, and swaging occurs. Rotation of the dies is accomplished by opening and closing the handles.

After completion of swaging and removal of the fitting from the swaging tool, measure the outside diameter of the shank with a micrometer or with the gauge furnished with the swaging outfit to determine whether or not the terminal has been swaged sufficiently. This may be determined by checking the measurement with the applicable cable terminal table in NAVAIR 01-1A-8.

The pneumatic swaging tool shown in figure 16-29 is a lightweight portable unit designed to precision swage the metal of a terminal into the interstices (crevices) of the cable strands. The swager may be mounted on a baseplate and used on a bench, or it can be taken to the job. When the swaging tool is taken to the location of the job, it may be held in your hand or cradled in your arm.

The pneumatic swaging kit has several different sizes and types of dies used for swaging ball-and-sleeve terminals and for cutting and trimming cable. Like the mechanical swaging tool, the dies come in matched sets and must be used together. The dies are installed by inserting either die through the yoke opening into the die cavity. The keyway should be down and the shank facing the rear of the swager. Slide the first die back in order to clear the opening for the

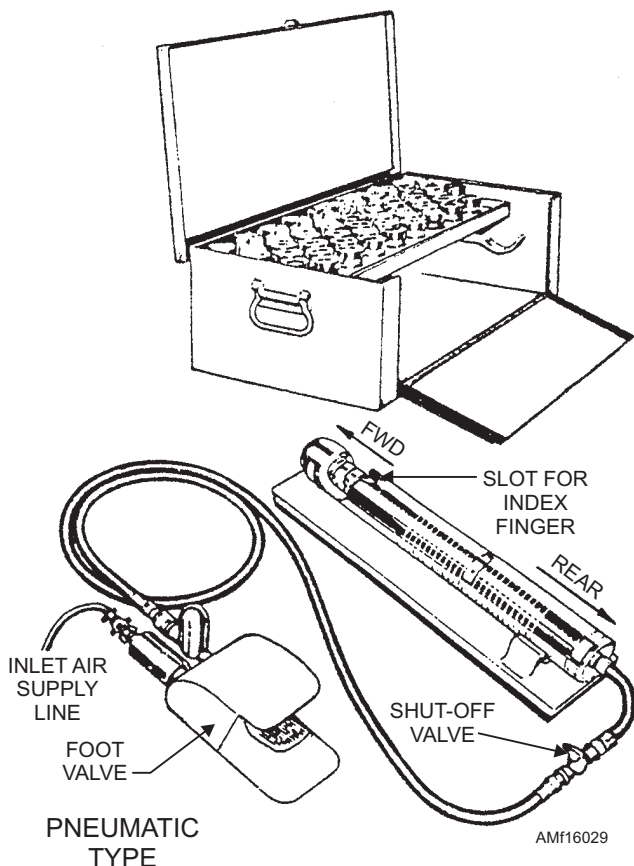
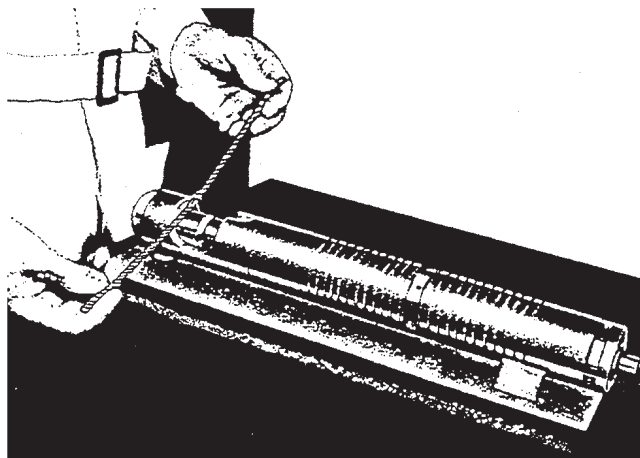
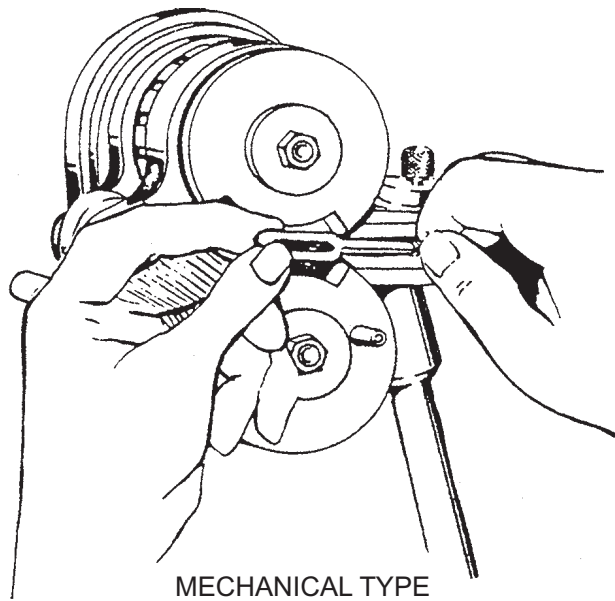

Figure 16-29.—Hand-swaging tools—mechanical and pneumatic.

cable toward the terminal, straighten it back to the normal position, and then push the cable all the way into the terminal barrel. This bending process puts a kink in the cable end to hold the terminal in place until the swaging operation is completed. It also tends to separate and spread the strands inside the terminal barrel and reduces the strain caused by swaging.



AMf16031

PNEUMATIC TYPE

Figure 16-31.—Locating the terminal in the swaging tool.

insertion of the mating die. The second die is inserted with the shank facing forward.

The following step-by-step procedures are recommended for setting up the pneumatic swaging tool:

1. Connect the air supply to the foot valve. For efficient operation, use an inlet air line with at least 3/8-inch inside diameter and a minimum of 90 pounds of line pressure.
2. Connect the swager air line to the foot valve.
3. Clean the dies, remove any steel particles that may have adhered to the die cavity, and apply a light film of oil to the entire die.
4. Insert the dies in the swaging tool as previously described.

WARNING

Do not insert or remove dies until the air supply that is connected to the swager is shut off. Failure to secure the air supply connected to the swager could result in personal injury to the operator.

With the pneumatic tool set up for use, perform the following steps while swaging terminals to cables:

1. Position the terminal on the cable, using the old cable as a pattern, or follow the instructions given in the applicable technical directives. When you are using a ball terminal, a minimum of 1 1/2 inches of cable must extend beyond the ball to allow room for holding and turning the terminal during swaging. The excess is trimmed, if necessary, after the swaging operation. When you use MS 20667 terminals, 1/4 inch of cable must extend through the terminal. On all other terminals, the cable is bottomed (inserted all of the way into the terminal).

2. Each terminal is cleaned with a suitable solvent, and then coated with a light oil.

3. With the terminals positioned in the cavity of the forward die, slide the rear die to its forward position using the slot provided in the yoke for the index finger.

NOTE: To prevent damage to terminal or cable during the swaging cycle, maintain light pressure on the cable towards the front of the swager. This holds the terminal and cable firmly in the forward die cavity.

4. Depress the foot valve firmly and rotate the cable back and forth in 180-degree arcs or complete revolutions. The length of time the foot valve is held depends upon the type and size of fitting being swaged. The proper time can be found by referring to the chart supplied with the pneumatic swaging tool. If the terminal will not rotate, stop swaging immediately; rotate the terminal 90 degrees, and start swaging again.

5. Release the foot pedal to stop swaging, and remove the terminal from the swaging tool for inspection. If the diameter is oversize or the terminal surface is too rough, repeat the operation.

If swaged terminals are to be used on both ends of the cable, recheck the overall length of the cable and trim it, if necessary, prior to installing the second terminal. Make certain that all additional fittings and accessories, such as cable stops and fairleads, are slipped onto the cable in the proper sequence. The other terminal may then be swaged, using the same procedures as used for the first one.

Proof (Load) Testing Cables

All newly fabricated cables should be tested for proper strength before they are installed in aircraft. The test consists of applying a specified tension load on the cable for a specified number of minutes. The proof loads for testing various size cables are given in tables contained in NAVAIR 01-1A-8. Proof loading will result in a certain amount of permanent stretch being imparted to the cable. This stretch must be taken into account when you fabricate cable assemblies. Cables that are made up slightly long may be entirely too long after proof loading.

- Q16-25. How many control cables are there in a simple cable system?*
- Q16-26. Other than periodical inspections, what else must be done to a control cable?*
- Q16-27. What is the maximum number of broken wires allowed in a 1-inch length of a 7 x 19 cable?*
- Q16-28. What is the maximum number of broken wires allowed in a 1-inch length of a 7 x 7 cable?*
- Q16-29. What is the maximum number of broken wires allowed per inch on a control cable passing over pulleys, drums, or through a fairlead?*
- Q16-30. What is the purpose of a quick disconnect in a cable system?*
- Q16-31. A simple rigid control system consists of what components?*
- Q16-32. After installing a new push-pull rod in a flight control system, what must be done to the control surface?*
- Q16-33. What is the purpose of a bell crank and a walking beam?*
- Q16-34. What is the purpose of a double-spring bungee?*
- Q16-35. The purpose of rigging and adjusting a primary flight control system is to regulate and limit surface deflection in both directions. What other purpose does it serve?*
- Q16-36. A tensiometer is inaccurate for measuring cable tension under how many pounds?*

- Q16-37. What is the actual tension on a 3/16-inch diameter cable if a No. 2 riser is used and the dial on the tensiometer reads 48?*
- Q16-38. When the control column is in neutral, the trailing edge of the control surface should be aligned to what degree on the throwboard scale?*
- Q16-39. With the aft sector rig pin in place, the elevators read 5 degrees above zero. What must you do to correct this?*
- Q16-40. A 1/8-inch flight control cable is composed of how many strands and wires?*
- Q16-41. What tools can be used to cut a small diameter cable?*
- Q16-42. What is the most satisfactory method of cutting a cable?*
- Q16-43. To achieve the most efficient operation when swaging a cable end fitting, you must use a 3/8-inch air line with at least how many pounds of pressure?*
- Q16-44. What manual contains information on proof testing various size cables?*

SECONDARY FLIGHT CONTROL SYSTEMS

LEARNING OBJECTIVE: Identify the various functions of secondary flight control systems. Identify maintenance procedures associated with each function.

Secondary flight controls, such as wing flaps and speed brakes, are usually hydraulically operated and either mechanically or electrically controlled. The design of these flight controls slows the aircraft in flight and provides additional lift and stability. These design features greatly increase the versatility and performance of the aircraft.

CONVENTIONAL WING FLAP SYSTEM

A flap is a hinged or pivoted section that forms the rear portion of an airfoil used to vary the effective chamber. Wing flaps in their most commonly used form are hinged sections of the trailing edges of a wing. Flaps extend from the fuselage to the inboard side of the aileron. Wing flaps are connected to the main wing by various kinds of hinges and slides.

The flap system discussed in this section is a representative system. The number of flaps will vary according to the size of the aircraft. The components may have different names, depending on the manufacturer, but the operational theory remains the same. This system consists of a series of six flaps, three on the trailing edge of each wing. They raise and lower in the conventional manner by a hydraulically actuated linkage of bell cranks, pushrods, and idlers. The flap control lever in the cockpit controls the system mechanically. The lever connects by conventional and teleflex cables to the hydraulic actuating mechanism. An emergency system is provided for lowering the flaps by operating a hand pump if the primary system malfunctions. The flap system has a position indicator and several safety devices to prevent lowering of the flaps while the wings are folded, or folding of the wings while the flaps are lowered.

The movement of the flap selector lever in the cockpit sets the flaps in motion. Movement of the selector lever operates a cable quadrant to which a set of conventional control cables attach. These cables connect to another sector just forward of the main wing beam. A teleflex cable, also attached to this aft sector, and a spring-loaded pushrod on the main flap actuating bell crank connect to the two ends of a short floating arm installed on the hydraulic selector valve lever. Figure 16-32 is a drawing of the cylinder, linkage, and selector valve installation. Reference to the index numbers on this drawing is made in the following description of the operation of the flap control system.

When the flap handle in the cockpit moves down, the upper end of the floating arm (9) pulls to the left,

pivoting at its lower end and moving the selector valve lever to the left. This action directs pressure from the hydraulic system to the flap actuating cylinder (1). The cylinder piston rod extends and lowers the flaps by rotating the flap drive bell crank (3) in a clockwise direction. As the bell crank moves, the lower end of the floating arm moves to the right by the spring-loaded pushrod (7). This action pivots the arm at its upper connection to the sector pushrod and returns the selector valve to neutral, stopping the action of the system.

Moving the flap handle upward reverses the foregoing procedure by pushing the selector valve lever to the right, directing hydraulic pressure to the retract side of the cylinder piston and raising the flaps. The follow-up rod then moves the lower end of the floating arm to the left and returns the selector valve to neutral. The valve will not return completely to neutral, maintaining pressure in the flap cylinder and ensuring positive locking of the flaps in the up position.

The spring mechanism in the follow-up rod normally does not function. The spring mechanism is provided only as a safety feature, permitting actuation of the flap drive crank by emergency hydraulic power if the selector valve becomes jammed.

The flap hydraulic system consists primarily of the selector valve and the actuating cylinder. See figure 16-33. The selector valve is a four-way, poppet-type valve. The poppets operate in pairs to direct pressure to one side of the cylinder while opening the other side to reservoir return.

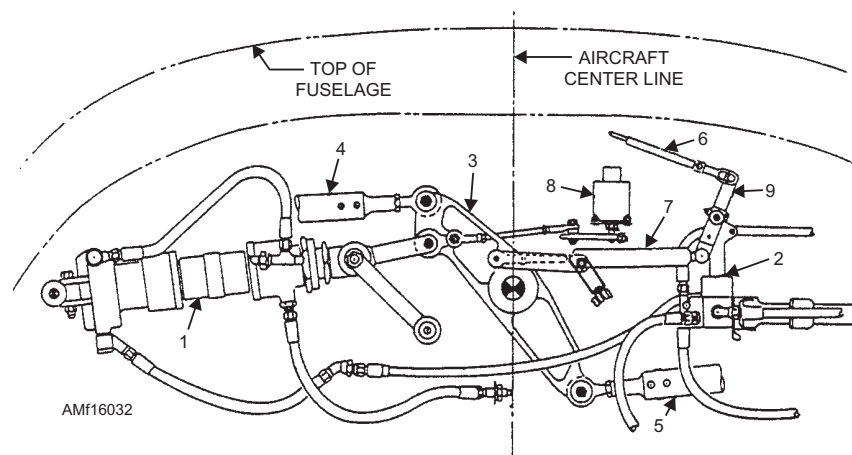

- | | | |
|------------------------------|--|---|
| 1. Wing flap cylinder | 4. Left flap control pushrod | 7. Follow-up pushrod |
| 2. Wing flaps selector valve | 5. Right flap control pushrod | 8. Flap position transmitter |
| 3. Flap actuating bell crank | 6. Flap control push-pull cable assembly | 9. Selector valve floating arm assembly |

Figure 16-32.—Flap cylinder, linkage, and selector valve installation.

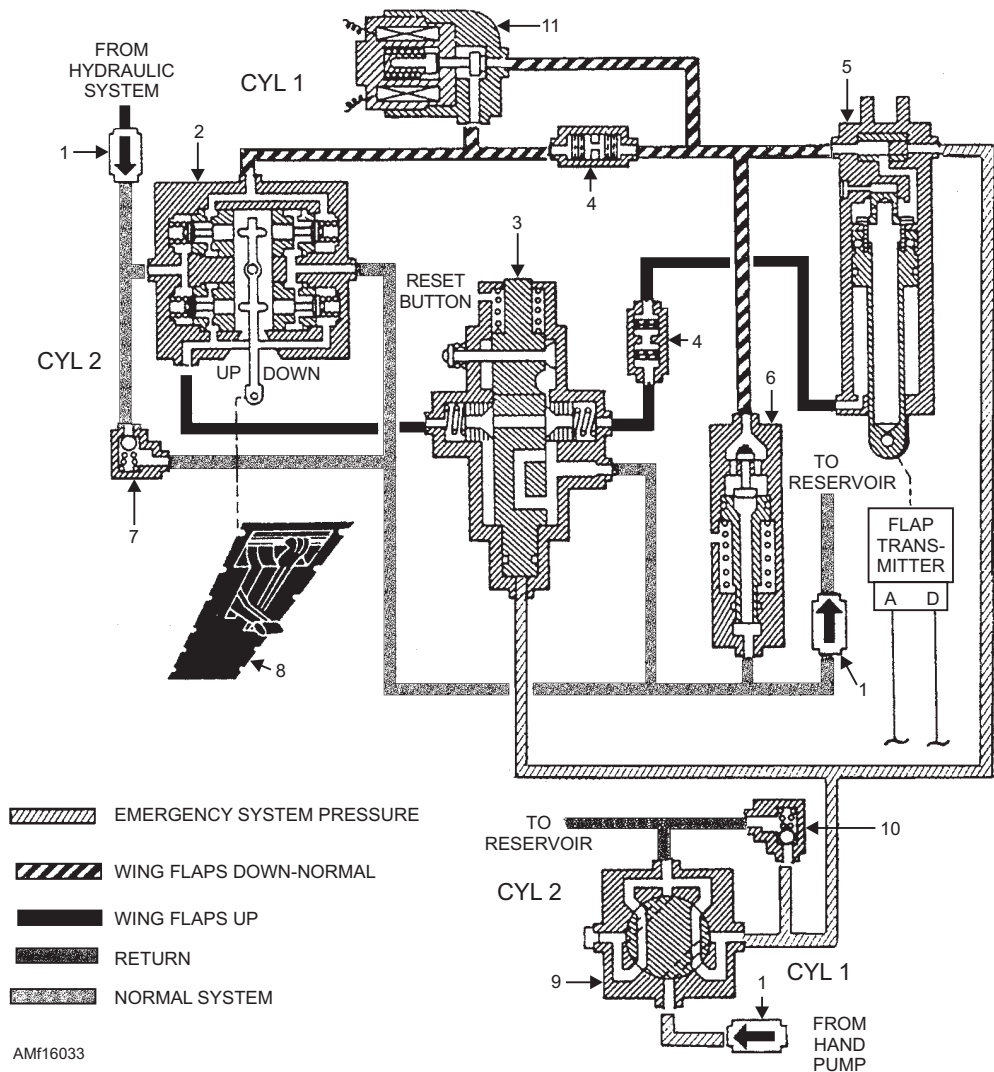

- | | | |
|-----------------------------------|-----------------------------------|---------------------------------------|
| 1. Check valve | 5. Wing flap cylinder | 9. Wing flap emergency selector valve |
| 2. Wing flap selectro valve | 6. Wing flap blowup relief valve | 10. Relief valve |
| 3. Wing flap emergency dump valve | 7. Wing flap thermal relief valve | 11. Wing flap snap shutoff valve |
| 4. Restrictor | 8. Wing flap control | |

Figure 16-33.—Wing flap system.

The cylinder is double acting and internally locked in the retracted (flaps up) position. The cylinder also has an integral shuttle valve (built into the mounting end cap). This provides for the separation between the normal and emergency hydraulic pressure lines. An adjustable terminal on the piston rod provides for length variation.

When the cylinder extends, the internal lock is hydraulically released, allowing the piston to move. When the flaps raise, the hydraulic pressure on the lock is relieved, and a compression spring engages the lock mechanism with the piston when the cylinder becomes fully retracted.

A relief valve installed in the normal flap down line provides a blowup feature that prevents overloading of

the flaps and flap linkage. This valve is adjustable to a narrow range between full flow and reseal, providing a controlled blowup feature. As the flaps blow up, the flap air load decreases, gradually reseating the relief valve and preventing further flap retraction.

In the landing configuration, the flaps are partially or fully down. Safety microswitches prevent folding of the wings until the flaps are in the full up position. To reduce the recovery interval aboard ship, the aircraft wings must be folded and the aircraft taxied forward as quickly as possible. A wing flap retraction shutoff valve installed in the flap down line expedites flap retraction. This normally closed, solenoid-operated, hydraulic shutoff valve energizes only when the weight of the aircraft is on the wheels. When

energized, the valve permits return fluid to bypass the restrictor in the down pressure line, permitting fast retraction of the flaps and quicker wing-fold operation.

A relief valve is located in the pressure line ahead of the flap normal system selector valve. The valve relieves pressure from thermal expansion, which may build up on the inlet side of the selector valve.

An emergency system for flap down operation includes a selector valve and an emergency dump valve. The emergency flap down selector valve is usually in the NORMAL position. In this position, the cylinder emergency line to return is vented. When you move the emergency selector valve handle to the FLAPS DOWN position, you can lower the flaps by operating the hand pump. This action directs hand pump pressure through the integral shuttle valve to the actuating cylinder. At the same time, the emergency dump valve is actuated. The emergency dump valve opens the up side of the cylinder directly to return and closes off its normal return line through the selector valve.

Once actuated, the dump valve must be reset manually to restore the system to normal operation. The emergency selector valve handle must first be returned to the NORMAL position, relieving the pressure in the emergency line. The dump valve is then reset by pushing the button on the dump valve. The button is marked PUSH TO RESET. With pressure in the normal system, the normal selector handle must be placed in the down position to reset the integral shuttle valve. The flaps will then raise using normal control, provided the flap up portion of the system is operative. There are no provisions for emergency retraction of the flaps.

LEADING/TRAILING EDGE WING FLAP SYSTEMS

Several types of naval aircraft are equipped with flap systems that feature both leading edge and trailing edge flap panels. On some aircraft these leading edge panels are referred to as slats.

Figure 16-34 shows a leading edge and trailing edge flap arrangement. The figure shows flap operation with aileron drooping and boundary layer control. These features create even greater lift and stability than with flaps alone.

This flap system consists of three leading edge and one trailing edge flap panels for each wing, with each panel having its own actuator. A three-position flap

control switch in the cockpit is labeled “UP, 1/2, and DN.”

The leading edge flaps operate by a manifold-mounted selector valve and dual actuating cylinders. Trailing edge flaps use this same selector valve plus a wing-mounted selector valve and dual tandem actuating cylinders.

When the flap control switch is placed in the 1/2 position, the manifold-mounted selector valve directs utility system pressure through the shuttle valves. Pressure is sent into the down lines of the leading edge flap actuators. The leading edge flaps are lowered to the full down position. The inboard leading edge flap deflection is 30 +0, -2 degrees. The center flap deflection is 60 +0, -2 degrees. The outboard flap deflection is 55 1/2 degrees ±1/2 degree.

At the same time, hydraulic fluid flows through the fuselage-mounted flow divider and into the extend side of the dual tandem trailing edge flap actuating cylinder. This action moves the trailing edge flaps to the 1/2 position with a deflection of 30, ±2 degrees. The cockpit flap position indicator indicates barber poles while the flaps are in transit and flap position at the completion of selected movement. The limit switches are connected into the control circuit in series to provide an indication of flap position and to continuously energize the electrical circuits to maintain hydraulic pressure when the flaps are down.

Moving the flap control switch to the full down position actuates the wing-mounted selector valve, porting pressure through a second flow divider. Pressure is sent into the down side of the retracted half of the trailing edge flap cylinder, moving the flaps from the 1/2 to the full down position. Full down position is 60 +1, -2 degrees. Both flap position indicators will indicate DN when the cycle is completed.

Placing the flap control switch to the UP position allows hydraulic pressure to be directed to the retract side of all flap actuators. Position indicators indicate UP. The electrical control circuits and solenoids of both selector valves are de-energized.

The leading edge flaps are locked in the UP position by the overcenter locking mechanism. The trailing edge flaps are locked up by internal locks within the trailing edge actuating cylinders.

HYDRAULIC DROOP AILERON SYSTEM

When the flap switch is placed in 1/2 or DN position, with PC 1, PC 2, and utility hydraulic power

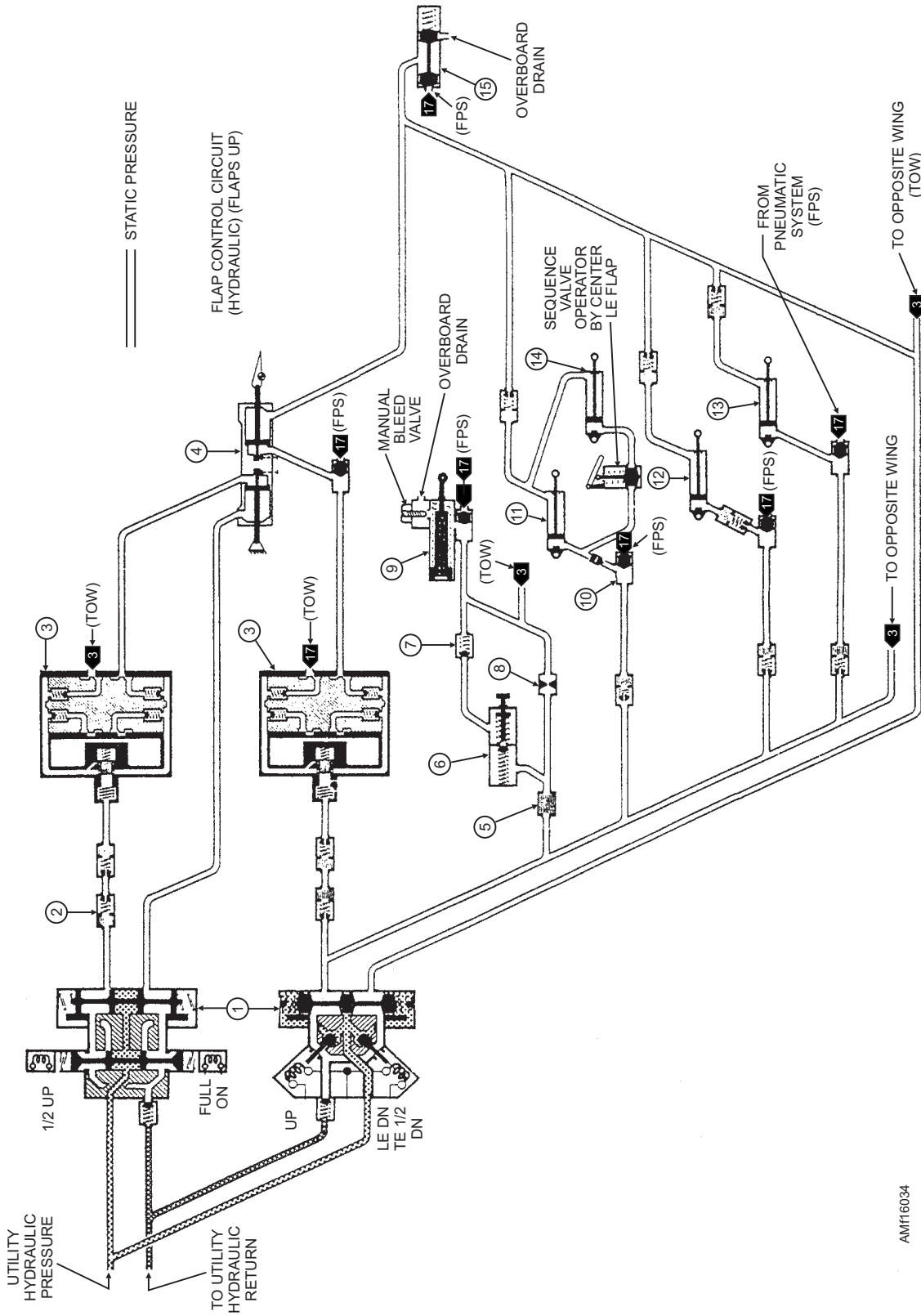

AMF16034

- 1. Solenoid selector valves
- 2. One-way restrictor valve
- 3. Hydraulic flow divider
- 4. Trailing edge flap actuator (2)
- 5. Filter
- 6. Manual hydraulic bypass valve
- 7. Check valve
- 8. Two-way restrictor valve
- 9. Aileron droop actuating cylinder (2)
- 10. Shuttle valve
- 11. Inboard L.E. flap actuator
- 12. Center L.E. flap actuator
- 13. Outboard L.E. flap actuator
- 14. Boundary lay control valve actuator
- 15. Dump valve

Figure 16-34.—Flap control circuit.

applied, the ailerons will extend 16 1/2 degrees down. The control stick will remain centered. The droop aileron actuating cylinder (fig. 16-34), one in each wing, extends by flap down utility hydraulic pressure. The droop aileron is retracted by springs in the cylinder when extend pressure is removed. The droop cylinder connects between the aircraft structure and an idler bell crank in the aileron power package linkage. With flaps up, the droop cylinder acts as a solid link. When the flap control switch is placed in the 1/2 or DN position, the droop aileron extend relay energizes. This relay completes the extend electrical circuit to the droop aileron actuators. As the actuators extend, the aileron power cylinder input levers reposition, and both ailerons droop as before. The actuators are de-energized by the integral extend limit switch. The ailerons are free to operate normally. When the flap control switch is placed to UP, the droop aileron extend relay is de-energized. The droop actuator reposition the aileron power cylinder input levers. Both ailerons move back to their normal position. The droop actuators are de-energized at the completion of the retract cycle by the integral limit switch.

EMERGENCY FLAP SYSTEM

If electrical and hydraulic power fails, the flaps can be lowered by the emergency system. An emergency flap extension bottle with a 300-cubic-inch capacity and charged to 3,000 psi provides a power source. Emergency extension is controlled by the emergency flap control handle, which is mechanically linked to the emergency flap air selector valve. Pulling the handle aft, the piston inside the air selector valve shifts, allowing high-pressure air to flow through a separate set of lines to shuttle valves in the flap system. The shuttle valves reposition, and air pressure extends the flap actuators. Air pressure also repositions the flap system dump valve, dumping return side hydraulic fluid overboard. The leading edge flaps extend to the full down position and trailing edge flaps to the 1/2 down position. The aileron drooping feature does not operate when the flaps are lowered by the emergency flap system.

SEMI-INDEPENDENT FLAP AND SLAT SYSTEM

This system consists of semi-independent flap and slat systems, which raise and lower using hydraulic motors drive units, torque tubes, and screw jack-type actuators.

Flap System

The flaps divide into two panels per wing at the wing-fold joint. Each panel is supported by two sets of tracks and rollers that are driven by two ball screw actuators. Pressure from the combined hydraulic system powers the flap drive motor and gearbox assembly, shown in figure 16-35.

If the combined hydraulic system fails, a hydraulic brake locks the hydraulic motor, and an emergency electric motor provides continued operation. Emergency flap extension and retraction is controlled by placing the EMERG FLAP switch on the throttle quadrant at either UP or DN. Cam-operated switches within the flap drive gearbox provide input signals to show the flap position on the cockpit-integrated position indicator.

Operation of the flap control handle energizes the solenoid-operated flap selector valve, directing hydraulic pressure to the extend or retract lines of the flap drive motor. The wings must be spread and locked to provide a complete electrical circuit through the wing unlock relay to the selector valve.

Placing the flap control handle to the TAKEOFF position completes the electrical circuit through the 30-degree switch and cam-operated flap drive gearbox limit switch to the selector valve. Pressure ports to the down side of the high-speed hydraulic motor, which drives the gearbox. The flap drive gearbox, through a series of torque tubes and offset gearboxes, drives all eight flap actuators.

The flap actuators, shown in figure 16-34, drive the carriage and attaching flaps out and down to the 30-degree position. The limit switch in the flap drive gearbox opens, de-energizing the selector valve circuit, allowing the valve shuttle to return to neutral, blocking flow to the motor, and preventing further flap extension.

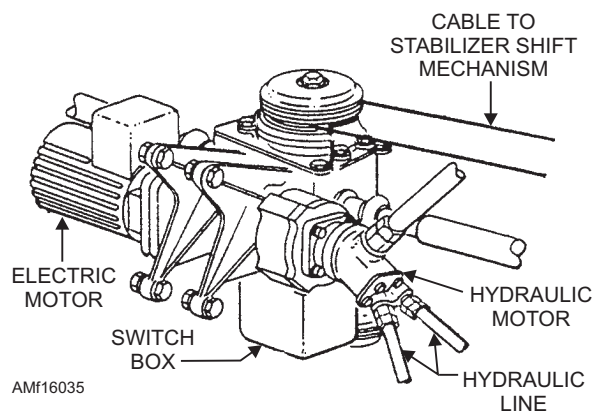

Figure 16-35.—Flap drive gearbox.

Placing the flap control handle to LAND mechanically closes the 40-degree down flap handle switch. The electrical circuit to the selector valve completes, this time through the now closed 40-degree down limit switch in the flap drive gearbox. The flaps will extend to 40 degrees, and the electrical circuit will be broken by the action of the limit switch.

Moving the flap control handle to the TAKEOFF or UP position will energize the opposite solenoid of the flap selector valve and port pressure to the retract side of the flap hydraulic motor. If the TAKEOFF position is selected, a limit switch will again halt flap movement at the 30-degree position. If UP is selected, retraction will be halted when the flaps reach the full up position. Stopping the flaps is a function of the flaps up limit switch. At the same time, linkage from the up limit switch actuates a second switch to complete the electrical circuit to the flap hydraulic motor brake valve. The energized valve blocks combined hydraulic system pressure that is holding the hydraulic brake in the unlocked position. The brake locks the hydraulic motor, which, in turn, locks the flaps in the up position.

If combined hydraulic system pressure fails and the emergency flap switch is used, the flap action is powered by the electric motor. See figure 16-35. The flap hydraulic brake valve is energized, and the pressure holding the spring-loaded hydraulic motor brake unlocked will port to return. The brake is then free to lock the motor and input shaft.

The electric motor now drives the flap gearbox and associated linkage, bypassing the locked hydraulic motor. This action occurs until the flaps reach a 40-degree trailing edge down position. Limit switches shut the electric motor off when the flaps reach the 40-degree down and full up positions.

FLAP ACTUATOR.—The flap actuator shifts rotary motion of the input shaft to linear flap motion, using bevel gears and the ball screw jack mechanism. See figure 16-36. A load-sensing device in each flap actuator operates a clutch assembly to stall out the flap system if it is overloaded. An impact plate at the end of the ball screw (screw jack shaft) and mechanical stops on the actuator body protect the actuator against possible overtravel during flap extension and retraction.

OFFSET GEARBOXES.—The eight offset gearboxes in the flap system transmit power produced by the flap drive gearbox around wing structure obstacles and compensate for wing angularity. They

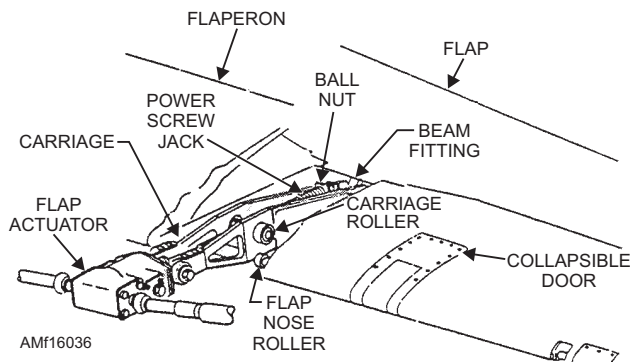

Figure 16-36.—Flap actuator.

also reduce the flap drive gearbox speed of 1,080 rpm to about 550 rpm at the outboard actuators.

FLAP WING-FOLD SHAFT.—A wing-fold shaft consists of two interlocking splined sections and two universal joints connected to quill shafts. It provides a telescoping fold joint in the flap drive system linkage between the inboard and outboard wing panels.

Slat System

The slat system, shown in figure 16-37, provides additional lift and stability to the aircraft at lower speeds in the same manner as the leading edge flap system previously discussed. The flap control handle controls the movement of the slats. Moving the flap control handle to the TAKEOFF or LAND position causes the slats to extend to a 27.5-degree leading edge down position.

The slat panels, one inboard and one outboard, interlock by a pin when the wings are spread. When fully retracted, the slats align with the top and bottom wing contours to form the wing leading edge. Shim spacers between the slats and the slat tracks provide adjustment for proper aerodynamic fairing.

Components of the slat system are similar to those in the flap system. The slats extend and retract by using six series-linked ball screw actuators. The actuators are powered by the hydraulic motor through gearboxes and torque tubes.

If combined hydraulic system pressure fails, the hydraulic motor is locked in the same manner as the flap hydraulic motor, permitting the emergency electric motor to move the slats. Emergency slat operation is accomplished simultaneously with emergency flap operation, using the emergency flap switch. Slat position is also displayed on the cockpit integrated position indicator.

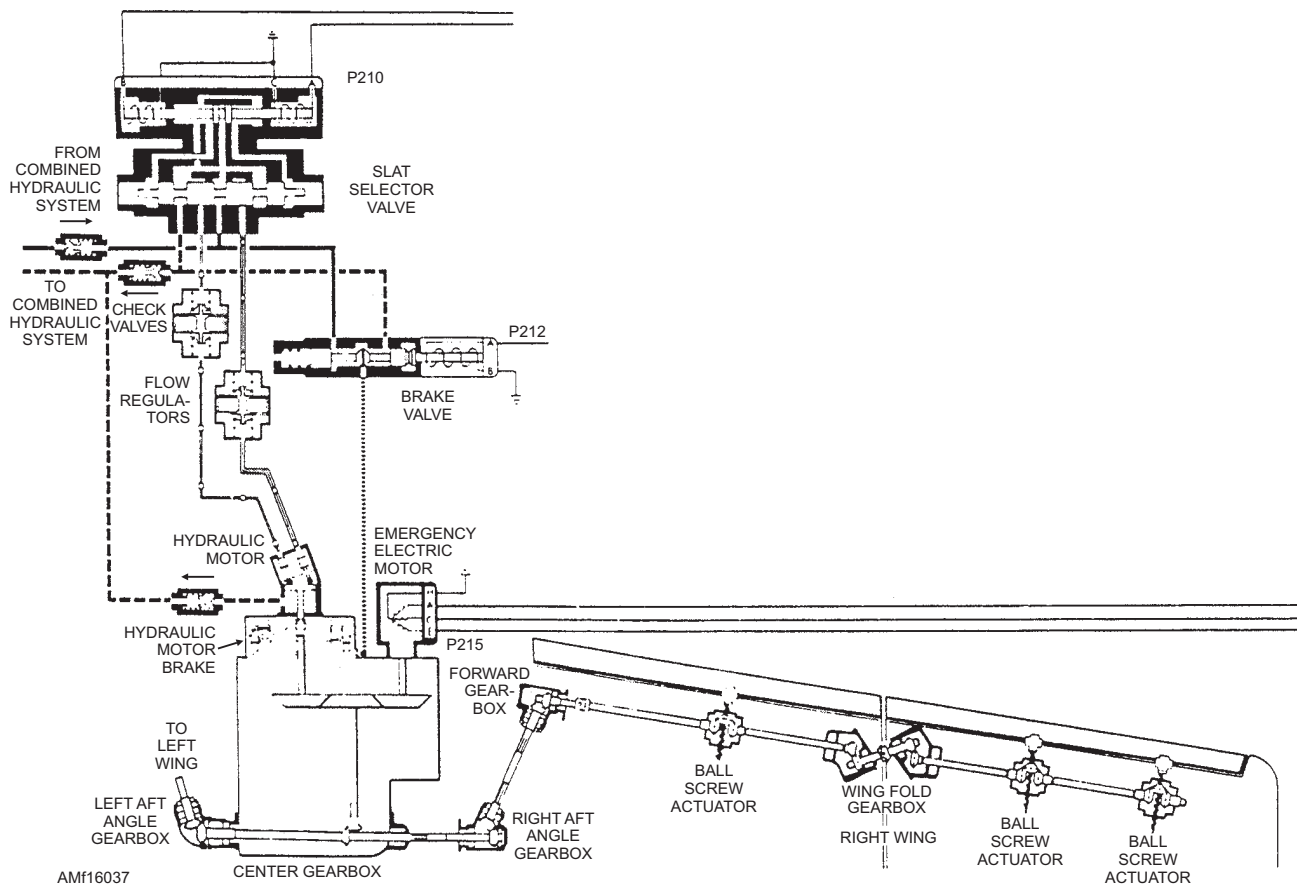

Figure 16-37.—Slat drive system.

Placing of the flap control handle to either the TAKEOFF or LAND position mechanically closes switches to provide electrical current to the slat selector valve. The selector valve ports hydraulic pressure to the extend side of the high-speed hydraulic motor. This action drives the center gearbox and extends the slats.

Two ball screw actuators drive each outboard slat, and one drives each inboard slat of each wing. Each actuator connects to its downstream actuator by torque tubes and gearboxes. The slats move as one unit. Limit switches in the center drive gearbox de-energize the slat selector valve, blocking flow to the drive motor when the slats fully extend (27.5 degrees) or retract. Placing the flap control handle to the UP position energizes the opposite solenoid of the selector valve and reverses slat motor direction, retracting the slats.

SLAT WING FOLD GEARBOX.—A wing fold gearbox disconnects slat drive linkage at the wing fold joint when the wings fold. The gearbox consists of two identical halves interconnected by a spring-loaded disconnect coupling when the wings are spread. As the disconnect coupling halves move away from each other during the wing folding operation, a

spring-operated brake engages, preventing relative motion between the inboard and outboard sections.

SLAT ANGLE GEARBOXES.—Four slat angle gearboxes are provided in the slat system for changing direction of the slat torque tube linkage from the center gearbox to the wing actuators.

DIRECT LIFT CONTROL (DLC)

Direct lift control controls the spoilers and horizontal stabilizers to increase aircraft vertical descent rate during landings. This may be done without changing engine power. Actuating the DLC engage-chaff dispense push-button switch on the control stick grip modifies the pitch and roll computer inputs. This modification causes the eight spoiler actuators to position their spoilers 3 degrees up from the 0-degree position. The pitch computer also generates the DLC servo actuator command drive at the time of DLC engagement. This command drive, which is applied to the DLC servo actuator, drives the stabilizers to the 6-degree trailing edge down position from the 0-degree position. In DLC, the pitch computer and the roll computer permit additional spoiler and stabilizer control through the DLC-maneuver,

flap-glove vane thumb wheel control on the control stick grip.

Rotating the thumb wheel fully forward, through modified spoiler and DLC command drives, extends the spoilers to the 12-degree position. The stabilizer is driven to the 8-degree trailing edge down position. Rotating the thumb wheel control fully aft retracts the spoilers to the -4.5-degree position and drives the stabilizers to 0 degrees. This maintains aircraft attitude while changing the vertical descent rate. Direct lift control can be disengaged by momentarily pressing the DLC engage-chaff dispense push-button switch or by setting either throttle lever to military power.

WING SURFACE CONTROL SYSTEM

The wing surface control system controls the variable geometry wings to increase aircraft performance at all speeds and altitudes. The system also provides high lift and drag forces for takeoff and landing. It provides increased lift for maneuvering, and at supersonic speeds, aerodynamic lift to reduce trim drag.

The wing sweep control initiated at the throttle quadrant provides electronic or mechanical control of a hydromechanical system that sweeps the wings. See figure 16-38. The wings sweep from 20 degrees through 68 degrees in flight. On the ground, a wing sweep position of 75 degrees is available (through mechanical control) for spotting the aircraft or enabling a wing sweep control self-test. See figure 16-39.

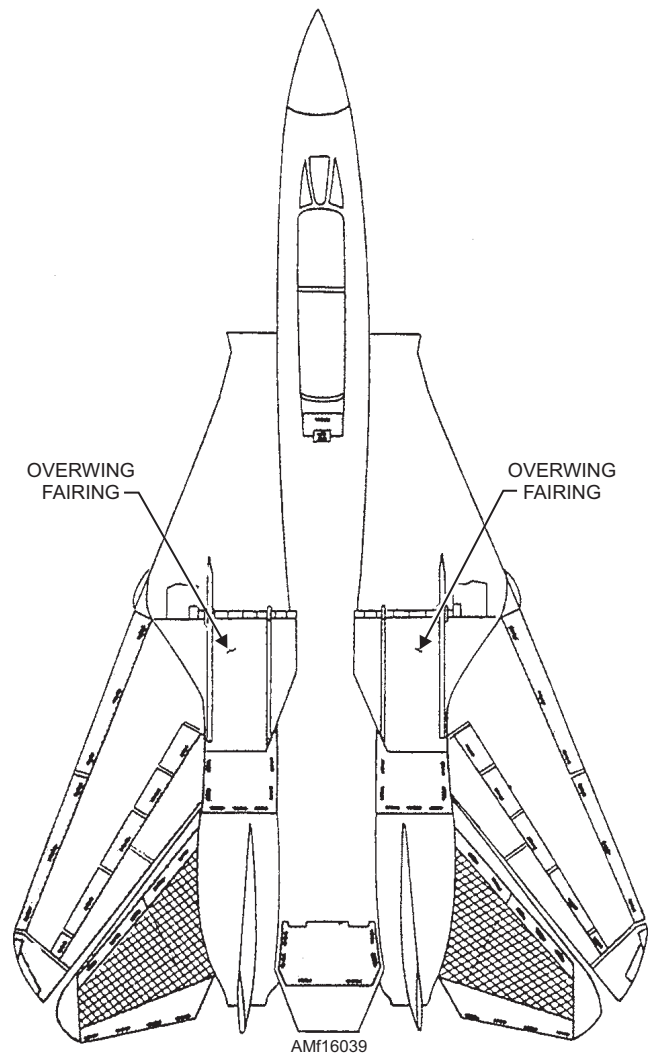

Figure 16-39.—Wing oversweep position—manual control.

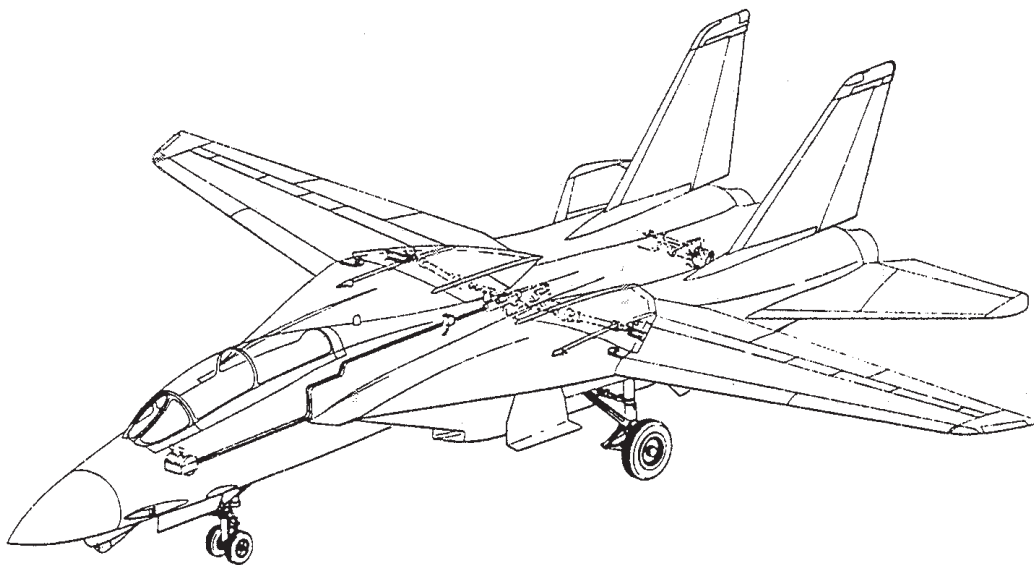

Figure 16-38.—Wing sweep control system.

Electronic Control

A wing sweep under electronic control is initiated at the throttle quadrant. Four modes are available—automatic, aft manual, forward manual, or bomb manual. Selection of these modes causes the air data computer to generate wing sweep commands consistent with the aircraft speed, altitude, and configuration of the flaps and slats. The commands are applied through the wing—flap glove-vane controller to the wing sweep control drive servo. They are converted to mechanical rotary force. This force, transferred to the wing sweep/flap and slat control box, causes the wing sweep hydraulic control valve to operate hydraulic motors that are driven by the flight and combined hydraulic power systems to sweep the wings. The flight hydraulic power system positions the right wing, and the combined hydraulic power system positions the left wing. A synchronizing shaft (fig. 16-38) interconnects the wings to ensure symmetrical operation. If a hydraulic system fails, it provides the driving force for sweeping the wing affected by the failed system.

Wing sweep commands generated by the air data computer are limited by the configuration of the auxiliary flaps, maneuver flaps, and slats. With the auxiliary flaps extended, wing sweep is limited to 21.25 degrees. The maneuver flaps, with or without slats extension, limit wing sweep to 50 degrees. To prevent structural damage to the wings during negative-g conditions, wing sweep is interrupted to prevent wing sweep changes until the negative-g condition no longer exists. In the automatic mode, the wings are positioned at a rate of 7 degrees per second.

Mechanical Control

When wing sweep is under mechanical control, the wing sweep handle positions the wings through the wing sweep/flap and slat control box. Because the minimum wing sweep limiting is not available under mechanical control, the wings can be swept to an adverse position that could cause damage to the wings. Mechanical control is used for emergency wing sweep and wing oversweep.

During emergency wing sweep, the wing sweep handle, mechanically coupled to the wing sweep/flap and slat control box through a cable assembly, positions the wings. The wing sweep can be returned to electronic control by repositioning the wing sweep handle to the stowed position.

Wing oversweep can only be obtained with the aircraft weight on the wheels. Wing oversweep, shown in figure 16-39, reduces the amount of space required for spotting the aircraft. A wing sweep self-test can only be performed while the wings are overswept.

SPEED BRAKE SYSTEM

Speed brakes are hinged, movable secondary control surfaces used for slowing down the speed of the aircraft by increasing the profile drag. These surfaces are also called “dive brakes” or “dive flaps.” On some aircraft, they are hinged to and faired with the sides of the fuselage or they are attached to the wings. On the F/A18 aircraft the speed brake is located on the top, aft end of the fuselage between the vertical stabilizers. Regardless of their location, their purpose is the same.

Fuselage Type

The fuselage speed brake system is normally electrically controlled and hydraulically operated. See figure 16-40. In an emergency, it can be controlled manually.

The brake surfaces are installed on the sides of the aft portion of the fuselage below and forward of the horizontal stabilizer. They hinge at their forward end. When in the closed position, they fit flush with fuselage skin. An elevator speed brake interconnect provides a connection between the left-hand speed brake and the aircraft nose down elevator control cable. When the speed brakes open, the cable pulls and provides a nose down action to counteract the tendency of the aircraft to assume a nose up condition.

The speed brakes may be actuated by the two-position, spring-loaded-to-neutral control switch on the throttle lever or by the manual override control handle. When operating the switch to open the speed brakes, the control circuit energizes to operate the opening solenoid of the control valve. Pressure is sent to the actuating cylinders, extending the speed brakes. To close, the opposite solenoid energizes, repositioning the control valve and directing pressure to the retract side of the actuating cylinders, closing the speed brakes.

When you depress or pull the manual override handle to operate the speed brakes, a plunger manually positions the control valve to direct pressure to the actuating cylinders. The spring bungee connected to the manual control lever returns the manual override handle assembly to the neutral position when the

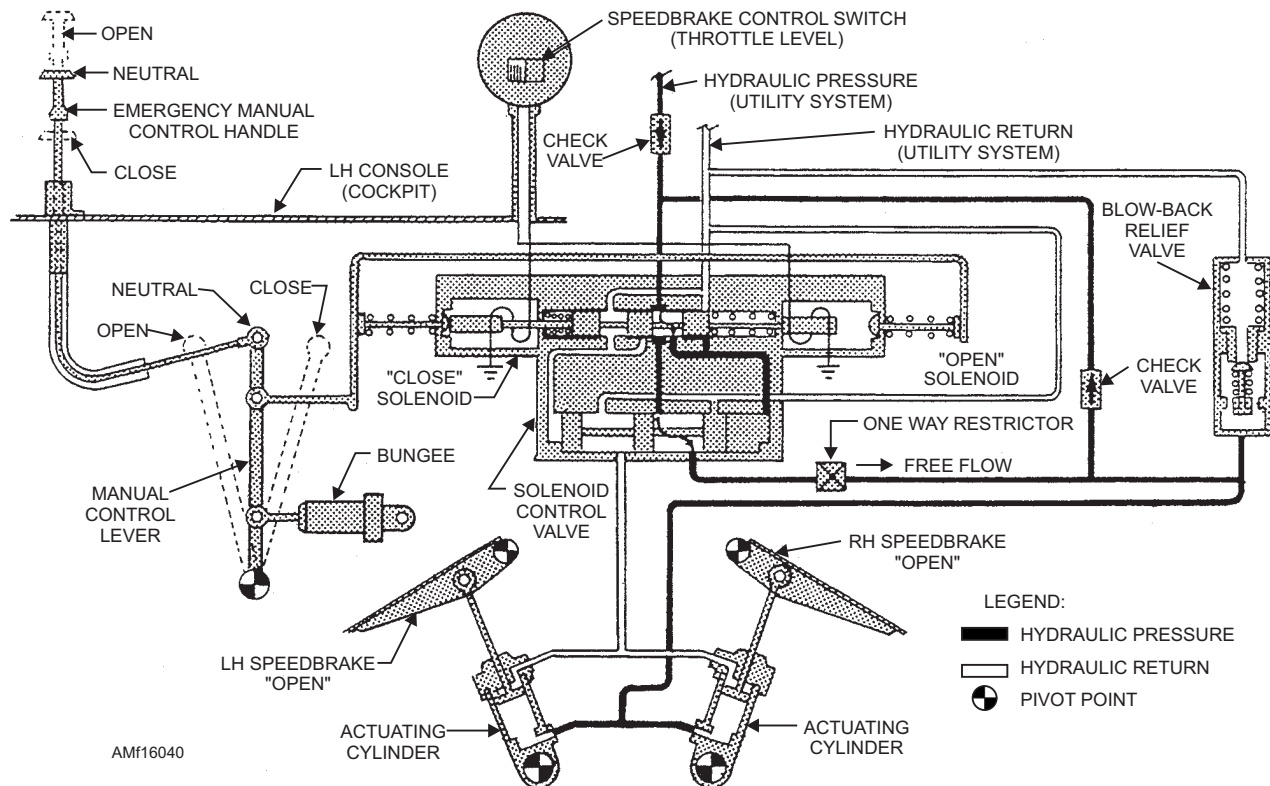

Figure 16-40.—Speed brake control system.

handle is released. If electrical power is applied while the manual override handle is actuated, the system will remain in the position selected by the handle. If the handle is released, the system actuates to the position selected by the control switch on the throttle lever. The speed brakes cannot be stopped at intermediate positions between fully closed and fully open. The restrictor in the open line restricts return fluid flow from the actuating cylinders when the speed brakes are being closed.

If the hydraulic system fails, the check valve in the pressure line traps pressure between the control valve and the actuating cylinders. If the speed brakes are open, this pressure will hold them open. If the speed brakes are actuated to the closed position, the pressure in the system will shift the primary slide in the control valve. This movement will relieve the trapped pressure and allow the speed brakes to close from the air load against them.

A blowback relief valve, installed in the hydraulic return line, allows for automatic retraction of the speed brakes under high air loads. When the speed brakes are open, the force of the airstream against the surfaces tends to force them closed. The force builds up the hydraulic pressure in the speed brake system. When the pressure reaches a maximum of 3,650 psi, it relieves through the blowback relief valve.

Wingtip Type

The wingtip speed brake system is an electrically controlled and hydraulically operated system. It operates either alone or with the fuselage speed brakes. See figure 16-41.

The wingtip brake consists of a set of trailing edge surfaces for each wing. The lower half attaches to the wing structure with two external fixed hinges. The upper half is attached to the wing at the same wing station with two adjustable tension lengths. An interconnecting hinge between the upper and lower halves provides a common connection point for the actuating cylinders. The hinge provides symmetrical deflection of upper and lower panels. Each panel can open up to 60 degrees for a total angle of 120 degrees for each wingtip brake. When retracted, they lie flush with the wing surface. They can extend and hold at any angle between 0 and 60 degrees, depending upon the amount of aerodynamic braking desired.

A mode selector switch permits simultaneous or independent operation of the wingtip and fuselage speed brakes, with the speed brake control switch located on the right throttle quadrant power lever. Moving the SPD BRK switch to the forward position closes the brakes. Moving it to center position holds the brakes at any desired angle. Moving it aft opens the

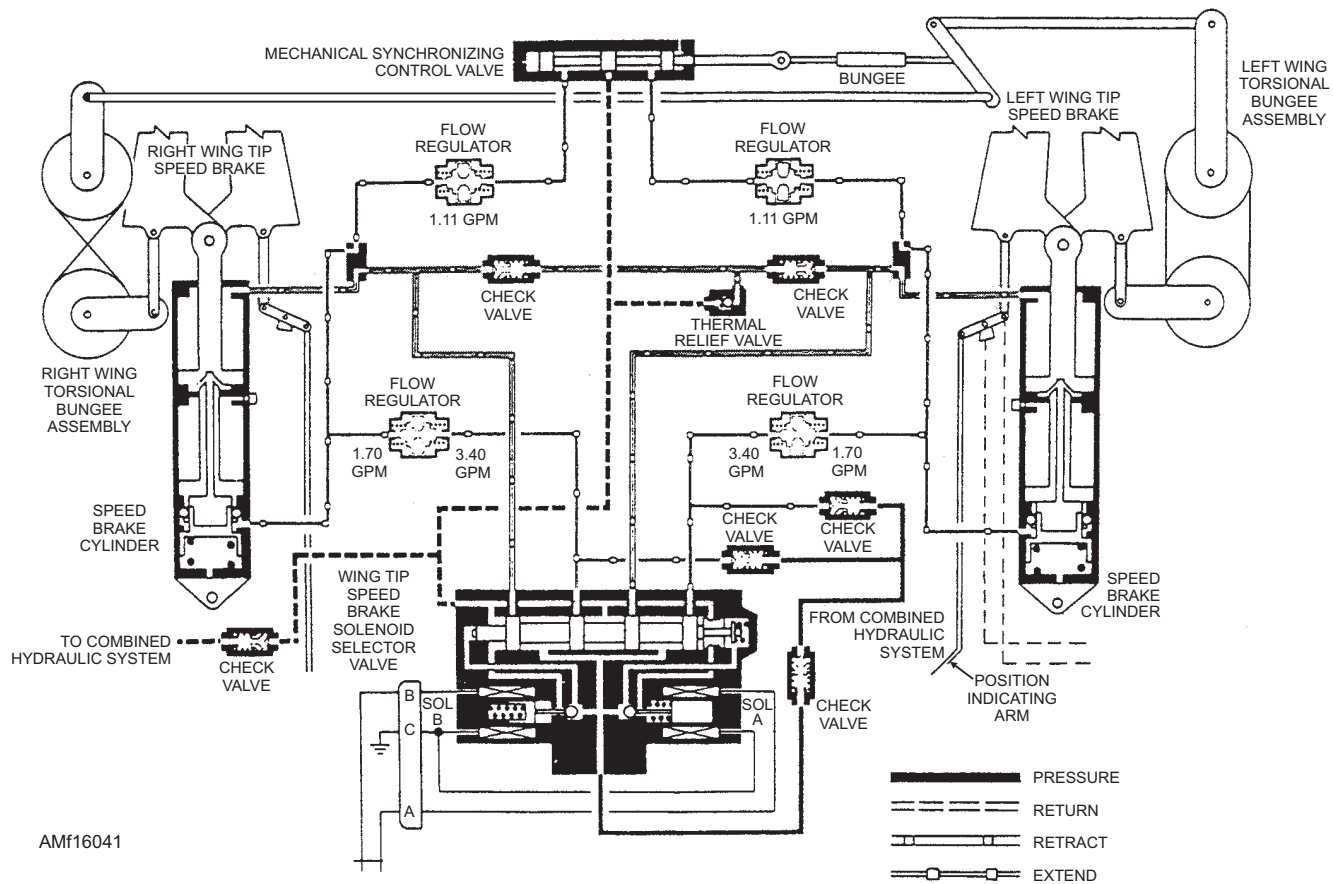

Figure 16-41.—Wingtip speed brake control system.

brakes. The switch is spring-loaded to neutral from the aft position only.

Selecting the open position energizes the selector valve, porting hydraulic pressure from the combined hydraulic system to the extended side of the actuating cylinder. When the switch is positioned to closed, the opposite solenoid energizes. Pressure is ported to the retract side of the actuating cylinders. With the switch in neutral, hydraulic fluid is blocked from both the extend and retract sides of the speed brake cylinders. This action hydraulically locks the speed brakes. If the electrical circuit fails, the selector valve is de-energized as a fail-safe feature and the speed brakes retract.

The wingtip speed brake control system normally depends upon the hydraulic flow regulators to maintain symmetrical extension of the left and right brakes. If a malfunction causes asymmetry of extension, an electrical disparity signal is sensed by the speed brake null detector. When the disparity between the extension of the left and right brake reaches 8 degrees, the null detector de-energizes the selector valves and causes the speed brakes to close.

On some aircraft, the synchronization mechanism (fig. 16-41) consists basically of synchronizing linkage, two torsional bungee assemblies, and a cable run interconnecting the three mechanisms to a mechanical synchronizing control valve. The synchronizing mechanism is a comparative linkage type that senses unequal motion between the two brake surfaces. Movement of either speed brake transmits through the torsional bungee assembly and the cables to the synchronizing mechanism. Any unequal movement upsets the synchronizing mechanism's neutral position, displacing the synchronizing valve shuttle. When the speed brakes are opening or closing, the valve is normally in neutral as long as the travel of both sides is equal. When unequal travel moves the valve shuttle out of neutral, the valve will relieve hydraulic pressure from the speed brake actuating cylinder, producing the largest opening angle. This decelerates the opening of the speed brake or bleeds down the speed brake with the largest angle until the disparity is within limits and the shuttle returns to neutral. On later models this mechanical synchronization system has been deleted.

If the mechanical synchronization system fails to maintain synchronization within 8 degrees, the

electrical fail-safe system operates and de-energizes the selector valve to close the speed brakes. If the synchronizing linkage becomes jammed, the torsional bungee assembly can be forced out of detent, isolating the linkage from the speed brake and preventing damage to the linkage because of overloads.

The bungee in the synchronizing mechanism linkage acts as a rigid length to the synchronizing valve during normal operation of the wingtip speed brake. If the valve becomes jammed, abnormal loads on the bungee will cause it to give and relieve the excessive loads before damage to the valve, linkage, or bungee occurs.

TRIM SYSTEM

A trim system is provided in the flight controls to lessen the need for constant effort on the part of the pilot to maintain the desired heading and altitude. The trim system stabilizes the aircraft during flight.

Lateral Trim

The aileron trim control system is shown in figure 16-42. The illustration represents a trim tab arrangement similar to that found on aircraft equipped with conventional aileron systems.

Operation of the lateral and longitudinal trim systems is usually controlled by a five-position, four-throw, momentary ON contact switch with a center OFF position. The switch is found on the control stick grip. This switch electrically energizes the trim control motor, which operates the trim control actuator to reposition the load-feel bungee and achieve hydraulic-powered actuation of the ailerons. At the

same time, the actuator operates the cable drum mechanism. The cable drum mechanism operates the jack screw mechanism to reposition the follow-up trim tab to aerodynamically maintain the aileron surface in a position corresponding to that achieved by the hydraulic actuation.

The tab movement does not control the lateral trim of the aircraft while normal powered flight is maintained. This is accomplished by the hydraulic-powered displacement of the ailerons. When the manual flight control system is used, the follow-up trim tab position introduced during powered operation becomes effective and maintains the same trim as that provided by the powered operation.

With the power system disconnected, further hydraulic trim control ends, and all future trim inputs are achieved through aerodynamic effect. This function depends upon selective follow-up tab position. Engaging the AFCS controls the trim actuator by electrical inputs.

Aircraft without trim tabs achieve lateral trim by repositioning the lateral control surfaces as necessary to achieve a balanced lateral flight condition. The trim actuator, located in the aileron trim and mixing linkage, normally acts as a series-connected, fixed-length rod in the aileron control system. The trim control switch on the stick grip controls the actuator length. Shortening or retracting the trim actuator (trim button to the right) supplies a left wing up input into the aileron control system linkage. Extending the actuator supplies a left wing down input. The trim actuator changes the neutral position of the aileron mechanism, allowing the control surfaces to deflect and trim the aircraft without moving the control stick.

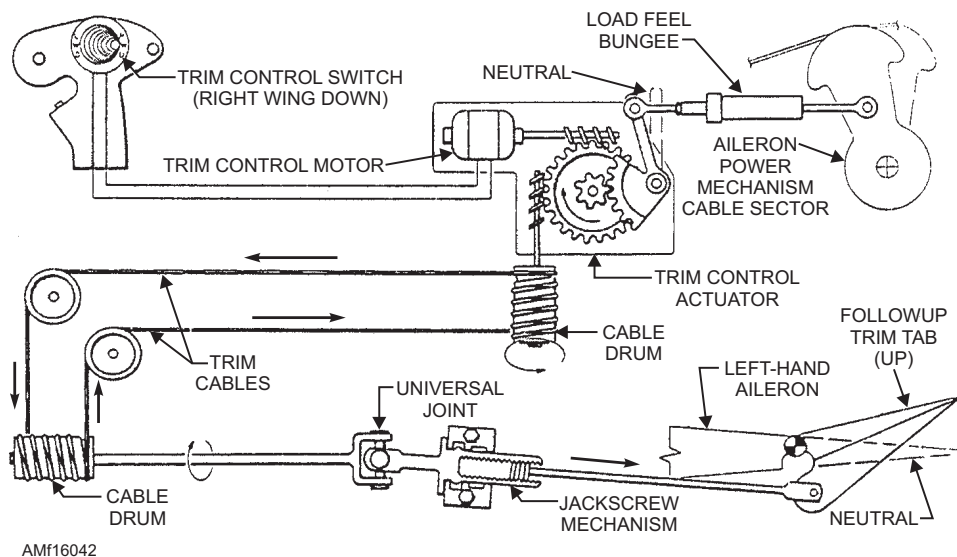

Figure 16-42.—Aileron trim control system.

Longitudinal Trim

Longitudinal or pitch trim can be accomplished in several ways. On aircraft with a nonmoveable horizontal stabilizer, trim could be provided by a trim tab arrangement or deflection of the elevators in much the same manner as described for the lateral trim systems.

Aircraft with a movable horizontal stabilizer and elevators are longitudinally trimmed by changing the angle of incidence of the stabilizer. Moving the four-way trim control switch on the stick grip fore or aft will raise or lower the leading edge of the stabilizer to provide the angle of incidence necessary for balanced flight. An electric trim motor and actuator arrangement provides movement of the stabilizer.

Aircraft that use a movable horizontal stabilizer for longitudinal control trim do so by varying the neutral position of the control linkage, which, in turn, moves the surface. For example, longitudinal trim is provided by varying the position of the artificial-feel bungee, repositioning the linkage, and setting up a new neutral position for the stabilizer linkage. Anytime a new neutral is introduced by the trim actuator, the power valve shuttle is displaced. The stabilizer assumes a new neutral location, changing the attitude of the aircraft. The trim inputs may be provided by the pilot or the automatic flight control system. The actuator has two operating speeds—high speed for manual trim and low speed for AFCS trim.

Directional Trim

Directional trim is necessary to compensate for yaw of the aircraft. Rudder trim is basically similar to the aileron trim. When the momentary throw rudder trim switch moves left or right, the trim actuator energizes to move the load-feel bungee, repositioning the rudder power mechanism input crank. The rudder linkage and the rudder are repositioned accordingly to a new neutral position.

Most aircraft with power-controlled actuators work in a similar manner, using an electric trim actuator to change the neutral position of linkage, deflecting the rudder to maintain the desired directional stability. Like the lateral and longitudinal trim systems, rudder trim action can be accomplished manually or automatically. Trim position indicators provide a cockpit indication of the amount of trim or surface deflection required by each trim system.

SECONDARY CONTROL SYSTEM MAINTENANCE

Organizational maintenance of the secondary flight control system includes checking system operation, rigging, periodic inspection, lubrication, isolation of malfunctions, and replacement of faulty components.

Proper operation of the gearboxes, interconnecting splined shafts, and screw jack actuators are dependent on proper lubrication. Lack of proper lubrication will generally result in binding and excessive loading of torque tube assemblies. Lack of proper lubrication promotes corrosion. Space and time limitations during shipboard operations often detract from the timely access to some of the slat and flap actuators. In many cases a wing spread and extension of the surfaces are necessary. Attention to these corrosion-prone areas will materially contribute to trouble-free operation of the screw jack mechanisms.

Repair of most of the gearboxes and screw jack actuators at the intermediate level of maintenance is limited to replacement of nuts, bolts, washers, gaskets, bearings, and shims. At the intermediate level of maintenance, components of a secondary flight control system may be disassembled for routine maintenance, such as cure date seal and miscellaneous parts replacement.

NOTE: Before disassembly of any component, reference should be made to the “Intermediate Maintenance” section of the applicable MIM or accessories manual to determine repair procedures and test equipment requirements. If the component is beyond the repair capability of a given activity, it should be forwarded through channels to an authorized higher level repair activity.

The repair process for many of the flap hydraulic components will generally include the following considerations:

1. Clean the disassembled part, using a suitable solvent followed by air drying with low-pressure air.
2. Inspect all parts, using a strong light and some means of magnification, or one of the nondestructive methods of metal inspection. Threaded parts are inspected for crossed, stripped, worn, or otherwise damaged threads. Springs are checked for distortion, permanent set, and alignment. Spring alignment may be verified by rolling them on a smooth, flat surface. The free length, compressed length, and reflected load of the

springs should be verified in accordance with the values provided in the applicable MIM.

3. Inspect mated surfaces for excessive wear, separation of plating, and evidence of nicks or scratches. All parts that show signs of excessive scoring, pitting, or other surface irregularities should be replaced. Minor imperfections can sometimes be removed with fine crocus cloth or lapping compound, depending on the design and tolerance specifications of the part.

4. Be sure that all passages and chambers of the part under repair are clean and free from obstructions.

NOTE: During the complete repair process, cleanliness of the work area, as well as the external and internal parts, is a prime consideration. The close tolerance mated surfaces within most hydraulic components are extremely susceptible to damage by contamination regardless of the manner of introduction.

Following reassembly, the component must be bench tested to verify its proper performance. Usually, testing will include proof testing, leakage testing to verify proper internal seal operation, and operational testing.

Quality assurance verification is required throughout the repair process and at the completion of repair. All repairs must be accomplished as specified in the “Intermediate Maintenance” section of the applicable MIM or 03 accessories manuals. Steps that require quality assurance verification are so indicated by appearing in italics, being underlined, or some other obvious manner. Following repair, partially fill the component with preservative hydraulic fluid and cap and/or plug to prevent contamination.

Q16-45. What components connect the wing flaps to the main wing assembly?

Q16-46. What is the purpose of the relief valve located in the pressure line ahead of the flap normal system selector valve?

Q16-47. In a leading/trailing edge flap system, what is the full-down deflection of the trailing edge flap?

Q16-48. What component provides the power source for the emergency flap system?

Q16-49. What component of the wing flap system shifts rotary motion to linear motion?

Q16-50. Moving the flap control handle to the TAKEOFF position will move the slats to what position?

Q16-51. The wing control system provides high lift and drag forces for takeoff and landings. What other advantages does the wing control system provide?

Q16-52. When is the only time a wing sweep self-test can be performed?

Q16-53. What flight control is used to slow down the aircraft speed by increasing the profile drag?

Q16-54. What type of switch is used to control the aileron trim system?

Q16-55. How does an aircraft that does not have trim tabs achieve lateral trim?

Q16-56. How is longitudinal trim achieved on an aircraft that has movable horizontal stabilizers and elevators?

MAJOR ASSEMBLY REMOVAL/INSTALLATION

LEARNING OBJECTIVE: Recognize the procedures for removal and installation of wings, stabilizers, and flight control surfaces.

The primary flight control surfaces and some of the secondary control surfaces are attached to the wings and stabilizers of the aircraft. In many instances, the wings and stabilizers are damaged beyond repair. When this occurs, the wings and stabilizers must be removed and sent to a depot-level maintenance facility for repair, and a replacement installed.

WINGS

Removal and installation of a wing are major operations that require experienced personnel and close supervision by a senior petty officer.

You should read the airframes section of the applicable MIM carefully before attempting to remove a wing. This manual will give step-by-step instructions for wing removal and installation. It is necessary to follow these instructions to prevent possible damage caused by failure to disconnect or connect units in the proper sequence.

Listed below are some general precautions that you should observe when removing and installing a wing or wing section.

1. The aircraft should be placed in a hangar or other area protected from the wind.

2. Make certain all the necessary equipment is available and at hand. A list of the necessary special tools and equipment can be found in the applicable MIM.

3. Ensure that you have sufficient manpower for proper handling.

4. Ensure that all screws, bolts, and other removed fasteners are placed in containers and properly marked to prevent loss.

5. Ensure that all removed fairings are marked and stowed in a safe place.

6. In disconnecting tubing, electrical connectors, control cables, and bonding wires, see that the instructions given in the aircraft MIM are carried out.

7. Make certain that all disconnected tubing is capped.

8. If hoisting equipment is to be used, be sure it is in good condition and a qualified operator is available. Also, ensure the hoist fittings are properly installed. Some wings will not balance at their hoist fittings, which makes it necessary to attach guide ropes to keep the wing steady after it is disconnected from the aircraft.

9. Before attempting to remove any structural bolts, make certain that the wing is properly supported with all loads removed from the fittings. A mallet and brass drift pin may be used in removing these bolts.

10. After the wing is removed from the aircraft, all fittings, connections, and unremoved structural members should be inspected for secondary damage before installing the new wing or wing section. (Secondary damage is damage to adjacent structures, which may have resulted from the transmission of the shock or load that caused the primary damage.)

11. Before installing the new wing, you should take advantage of improved accessibility to inspect and repair corrosion damage, and renew preservative coatings in previously inaccessible areas.

The petty officer in charge should ensure that the following general precautions are taken in installing a wing or wing section.

1. Check the identification tag of the new assembly to make sure it is the correct replacement unit.

2. See that extreme care is taken in removing the wing from the container, preventing any possible damage.

3. Inspect the new wing or wing section for possible damage incurred during shipment or removal from the container. The container should be used for shipping the damaged wing to the depot maintenance facility.

4. With the wing in position for installation and properly supported, ensure that all structural bolts are installed and the nuts properly torqued.

CAUTION

The attaching bolts should never be forced; if they bind, check alignment of the wing. Forcing the attaching bolts will result in damage to the wing structure.

5. Make certain that all tubing, electrical connectors, control cables, and any other disconnected mechanisms are properly connected.

6. Check the operation of all mechanisms that were disconnected during removal. Make the necessary rigging adjustments in accordance with the applicable MIM before installing access doors and fairings.

7. Make a final inspection of the completed job.

STABILIZERS

The removal and installation of stabilizers are similar, in most cases, to that of wings and wing panels. On many aircraft the horizontal stabilizer is a movable airfoil, controllable from the cockpit. On some of these aircraft, it is used in conjunction with the elevators to maintain longitudinal control at sonic speeds where the elevators have a tendency to lose their effectiveness. On other aircraft the movable horizontal stabilizer serves the dual purpose of elevators and stabilizers and, in many instances, is referred to as a stabilator.

Some aircraft have an empennage or tail group that consists of all-movable horizontal stabilizers and a single all-movable vertical stabilizer. These aircraft do not have elevators or a rudder.

The removal and installation of stabilizers, like that of the wing, are major jobs and must be accomplished with care and close supervision. Step-by-step instructions of the removal and installation of stabilizers are also included in the "Airframes" section of the applicable MIM. Many of

the general precautions listed under “Removal and Installation of Wings” also apply to stabilizer removal and installation.

FLIGHT CONTROL SURFACES

It is sometimes necessary to remove control surfaces from aircraft to repair or replace them. The instructions presented in the following paragraphs are general instructions, applicable to several types of aircraft. For specific instructions and precautions, you should always consult the MIM before removing a control surface from any aircraft.

Removal of a control surface should not be attempted until the aircraft is placed in a hangar or an area protected from the wind. Before any control surface is removed from the aircraft, it should be tagged with the bureau number of the aircraft and the location of the control surface on the aircraft.

The first step is to remove the access covers and fairings. To prevent the loss of these parts, they should be left attached to the aircraft by one screw or by a piece of safety wire. The other screws should be put in a container to prevent them from being lost.

Disconnect bonding wires, electrical connectors, and control linkage. Before disconnecting cable linkage, you should relieve the tension at the most convenient turnbuckle. Next, support the entire control surface, either manually or with mechanical supports, in such a manner as to remove all the load from the hinges. Remove the hinge bolts by using a mallet and brass pin. The control surface should be supported and all the hinges kept in alignment until the last hinge bolt has been removed. On long control surfaces, it may be necessary to replace the hinge bolts with drift pins to keep the hinges aligned while removing the remaining hinge bolts.

Control surfaces are sometimes attached with piano wire hinges. Removal of the piano wire can be accomplished by removing the ends, securing one end of the wire in the chuck of a hand drill, and rotating the wire with the drill while withdrawing it. Excessive spinning will have a wearing effect on the hinge material and should be avoided. The reuse of piano hinge wire is not safe; therefore, any wire removed should be discarded.

After all the hinges are disconnected, remove the control surface from the aircraft and support it carefully to prevent damage to the hinge brackets and

adjoining surfaces. Replace the hinge bolts in the hinges to prevent them from being lost or damaged.

Before installing a control surface, check the identification tag to determine its proper location on the aircraft. Place the surface in position carefully. You should ensure that all the hinge holes are properly aligned. Drift pins may be used to align the holes. With the control surface correctly supported, install the hinge bolts. For a surface attached by piano hinge wire, a new wire should be used. After a control surface is installed, connect the control linkage and check the rigging of the system.

Q16-57. Who must supervise the removal and installation of a wing assembly?

Q16-58. What is the first step the person in charge must perform before installing a new wing assembly?

Q16-59. Many of the general precautions listed under the removal and installation of what component apply to the removal and replacement of a stabilizer?

Q16-60. What tool is used for removing the piano wire of a flight control surface?

Q16-61. When installing a flight control surface, what tool is used to ensure that the hinge holes are properly aligned?

AIRFRAME AND CONTROL SURFACE ALIGNMENT

LEARNING OBJECTIVE: Identify the methods used to balance flight control surfaces and airframe/control surface alignment checks.

Alignment of the airframe structure means checking the position relationship of each major component—the wing group, tail group, and fuselage group—to the other. The alignment of the airframe is important since it is directly related to the aerodynamic performance of the aircraft. Misalignment may affect the flight characteristics of the aircraft, and consequently, the efficiency of the pilot-aircraft combination.

For this reason and for purposes of determining if any hidden structural failures exist, an alignment check should be performed when an aircraft has encountered excessive g's in flight, when a hard landing has been experienced, or when the aircraft has been subjected to extensive damage.

The need for an alignment check after extensive damage is rather apparent; however, this is not necessarily so in situations where the aircraft exceeds the g design limit or where a hard landing has been experienced. The alignment check under these conditions may expose damage that might otherwise go unnoticed.

BALANCING CONTROL SURFACES

Some flight control surfaces are balanced at the time of manufacture by adding counterweights to the inside of the leading edge of the control surface. This balance must be maintained (within certain tolerances) throughout the service life of the control surface because flutter or dynamic oscillation of these surfaces in flight is not desirable. Balance tolerances are always specified in the aircraft structural repair manual.

ALIGNMENT LEVELING METHODS

Prior to making an alignment check, it is necessary to level the aircraft both laterally and longitudinally. This may be accomplished by using the transit, spirit level, or plumb bob and datum plate method. You should always use the method of leveling specified by the manufacturer.

When you are leveling an aircraft for an alignment check, the aircraft should be inside a hangar where air currents will not interfere with the accuracy of the alignment readings. Jacks should be used to control the attitude of the aircraft during the check.

Transit

The transit method is the most accurate. Transit leveling is accomplished by sighting specified points on the aircraft. Two longitudinal and two lateral points are used for this method. The reference points are sighted through a surveyor's transit. Figure 16-43 illustrates longitudinal and lateral leveling of an aircraft using the transit method.

Spirit Level

Aircraft that use the spirit level method have leveling lugs either built into the structure or provisions for mounting them on the structure. The leveling lugs are usually in the nosewheel well. Spirit leveling lugs are shown in figure 16-44.

NOTE: The leveling lugs should be inspected for possible damage or misalignment prior to leveling the

aircraft. In the event of damage to the leveling lugs, the repaired lugs must be calibrated by cross-reference with the transit leveling method.

Plumb Bob and Datum Plate

This method uses a datum plate or scale mounted on the deck of a compartment. Provisions for hanging the plumb bob are located directly above the datum plate. The aircraft is level when the plumb bob pointer is at 0 degrees on the datum plate. Figure 16-45 shows the plumb bob and datum plate method of aircraft leveling.

ALIGNMENT CHECK

The alignment or symmetry check is made after the aircraft has been leveled. This check is made by measuring the distance between certain points on the aircraft. These points are selected because they are relatively static and because their location will best reflect any misalignment. Most manufacturers recommend that the measurements be taken directly from one specified point to another. Figures 16-46 show typical alignment dimensions for an F/A-18 aircraft.

On other types of aircraft, drop points are provided at various locations for use in checking the alignment. Plumb bobs are dropped from each of these points to the reference plane (floor) so that the pattern for measurement may be described. When you are using this method, the elevation check dimensions are measured from the drop points to the reference plane; in this case, the floor. The horizontal check dimensions are measured from one point (described by the plumb bob), along the reference plane (floor), to another point.

If the alignment check measurements exceed the tolerances listed in the aircraft structural repair manual, the aircraft must be considered non-airworthy until a special disposition can be made by higher authority.

WING TWIST CHECK

With the aircraft leveled and the wings folded, it is possible to check the wings for twist. One checkpoint is provided on each wing. Clinometer readings taken at these points, when compared to the fuselage longitudinal clinometer readings, will enable you to determine the condition of each wing.

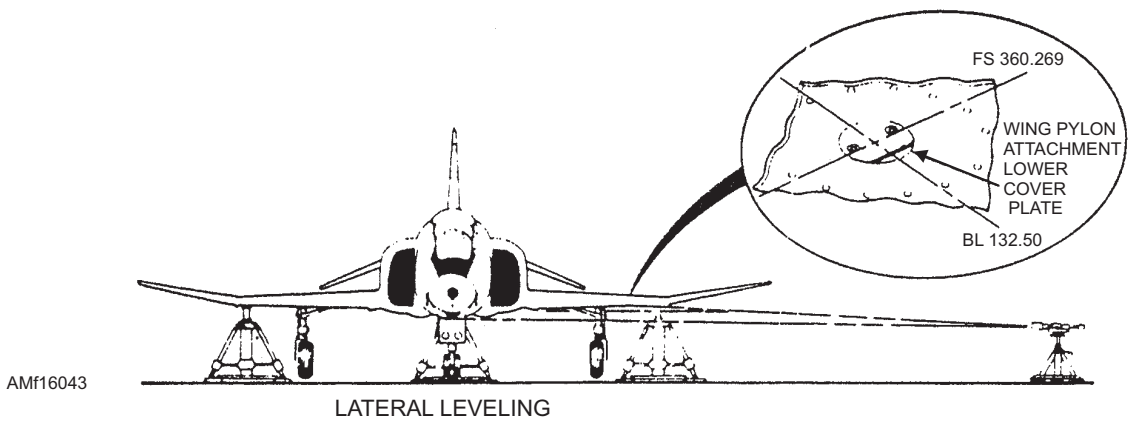
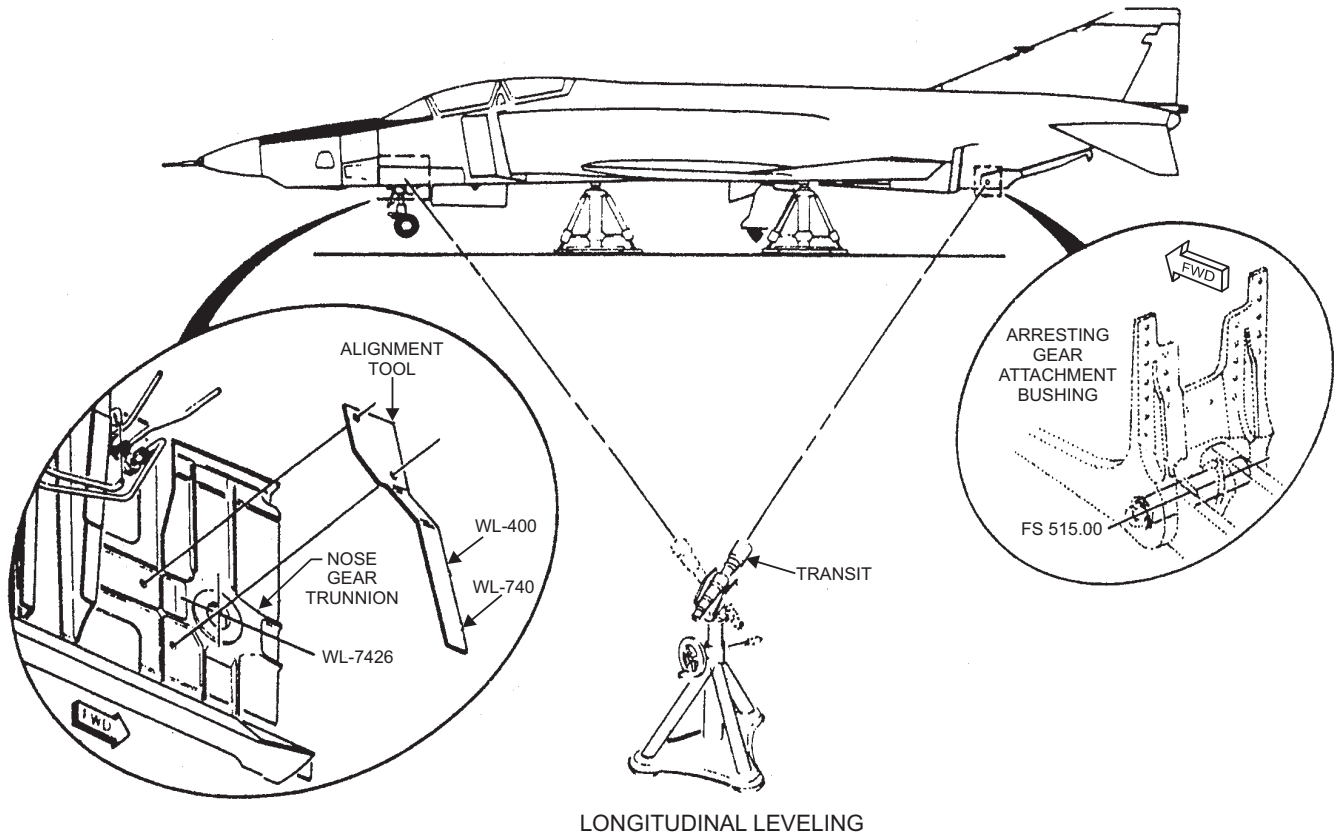

AMf16043

Figure 16-43.—Transit leveling.

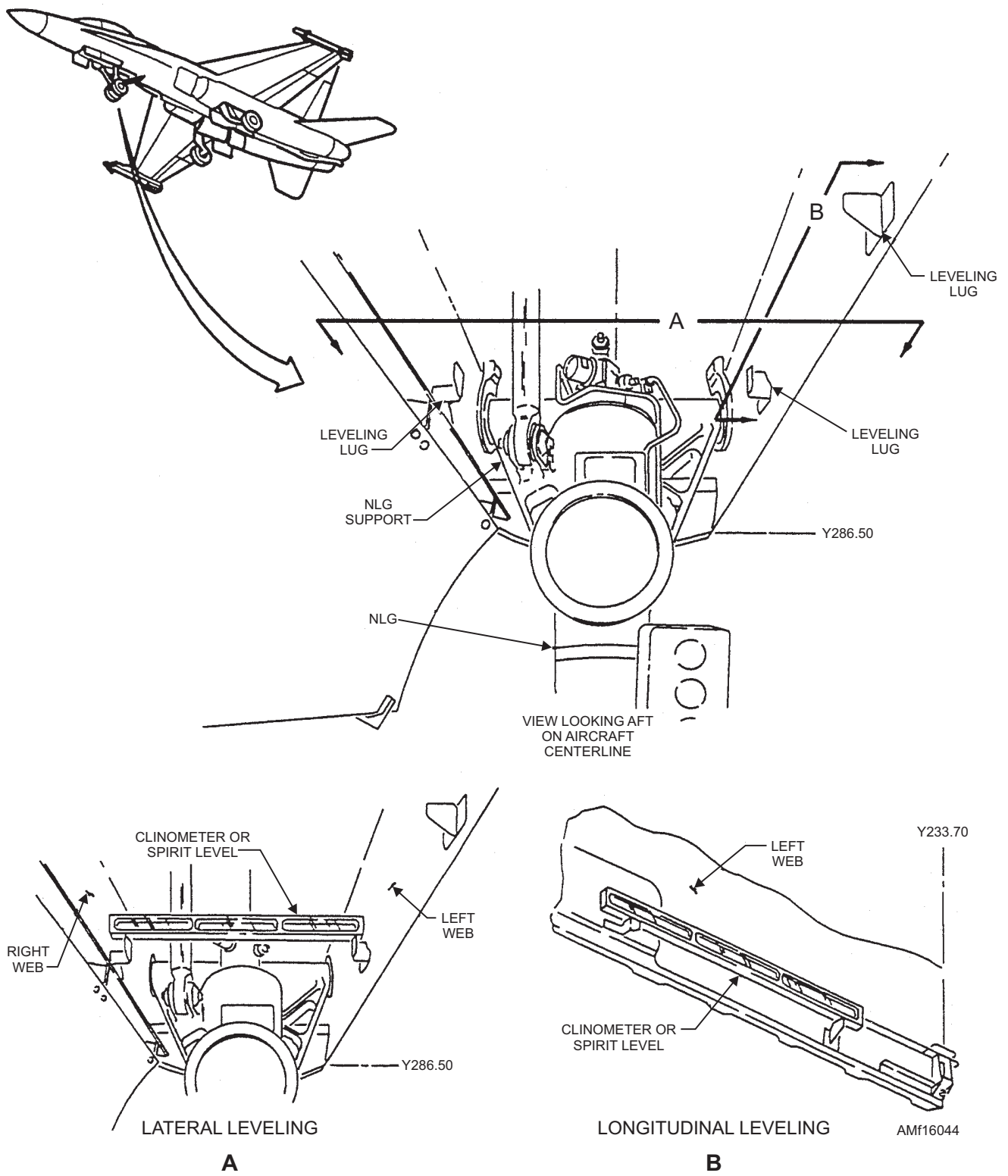

Figure 16-44.—Spirit leveling lugs.

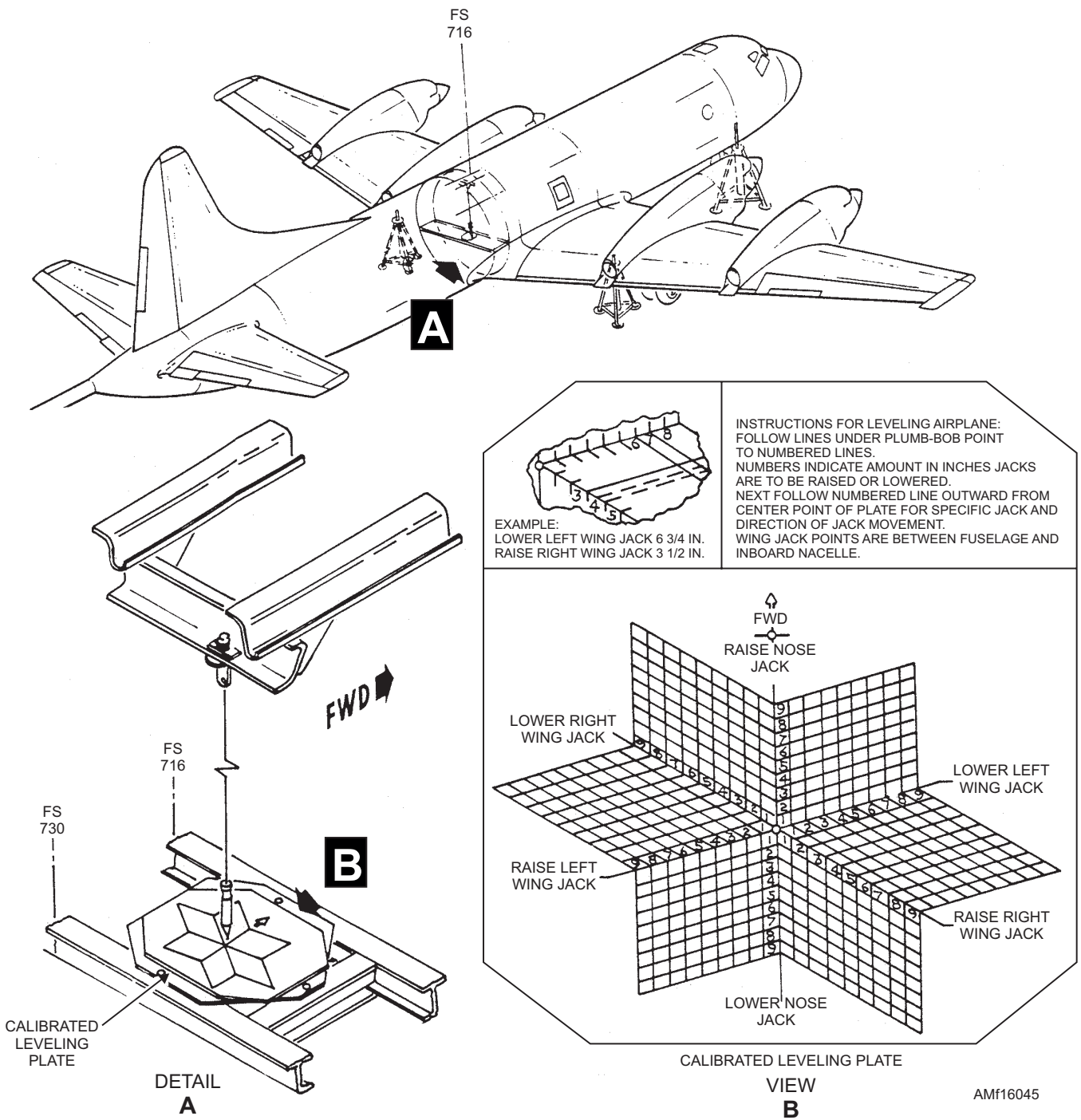

Figure 16-45.—Plumb bob and datum plate leveling.

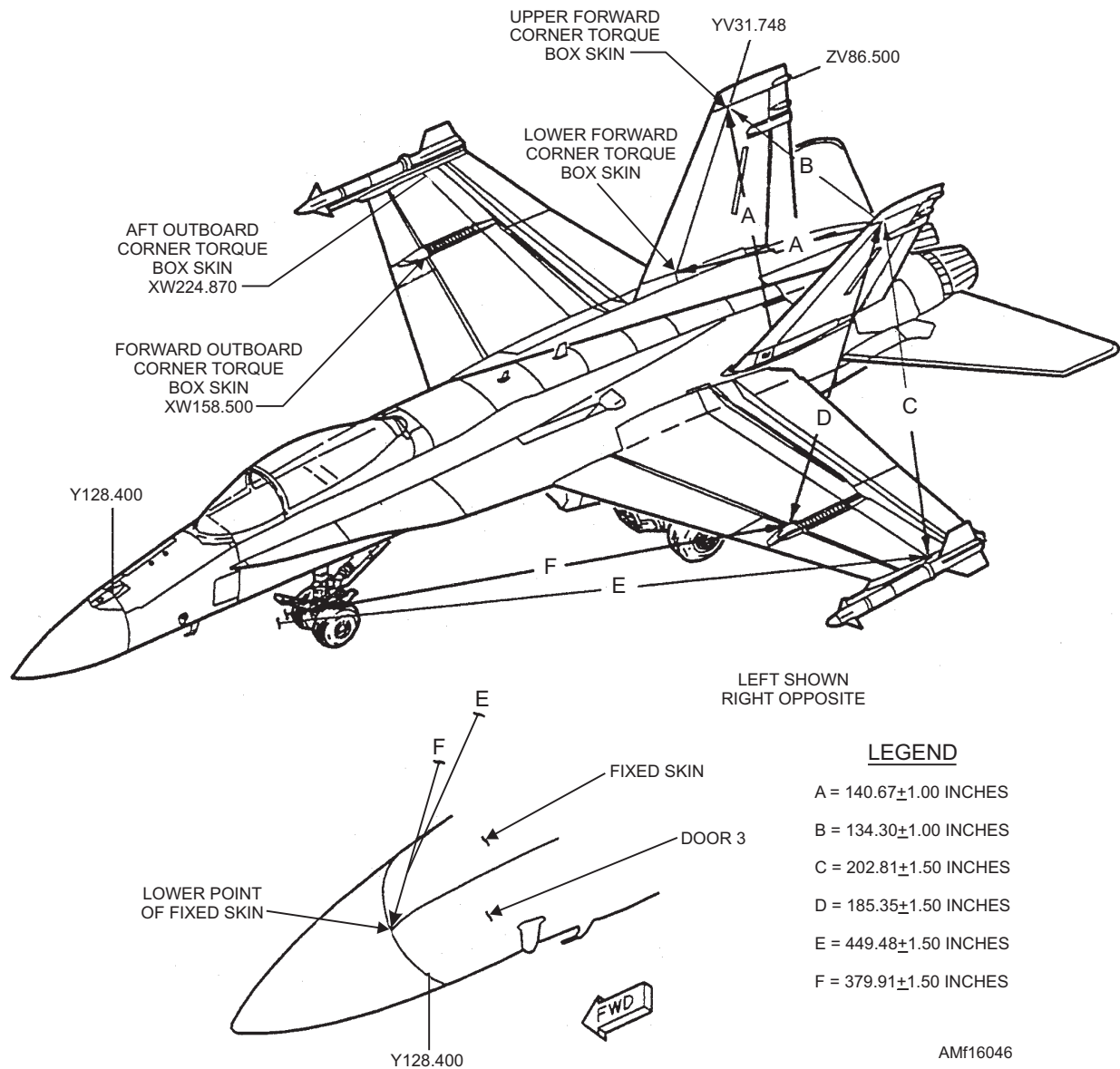

Figure 16-46.—Structure alignment dimensions.

This is possible because there is a definite relationship between the fuselage longitudinal and wing reference lines. You should follow the following steps to perform a wing twist check:

1. Fold the wings and level the aircraft laterally.
2. Install the leveling bar in the forward lockpin holes of the outboard panel fold rib.
3. Turn the rod until the milled flat at the forward end is straight up.
4. Set the clinometer on the flat and record the reading when the dial has stopped rotating.

The right- and left-hand wing readings must be within 0 degrees, 12 minutes of each other for acceptable aerodynamic tolerances with respect to twist. They must also fall within the following upper

and lower limits. The lower limit is established by subtracting 0 degrees, 20 minutes from the longitudinal reading, and the upper limit is established by adding 0 degrees, 40 minutes to the longitudinal reading taken in the auxiliary wheel well. For example, if the longitudinal reading was 1 degree, 35 minutes, the lower limit would be 1 degree, 15 minutes, and the upper limit would be 2 degrees, 15 minutes. Figure 16-47 shows a wing twist check on an aircraft. The wing clinometer readings must fall within this range as well as within 0 degree, 12 minutes of each other (right- to left-hand wing readings). This check, together with the steel tape measurements taken when the wings are spread, is a satisfactory check of wing bending and twisting. If the clinometer readings and tape measurements are not within the tolerances specified, the aircraft must be taken to a depot-level

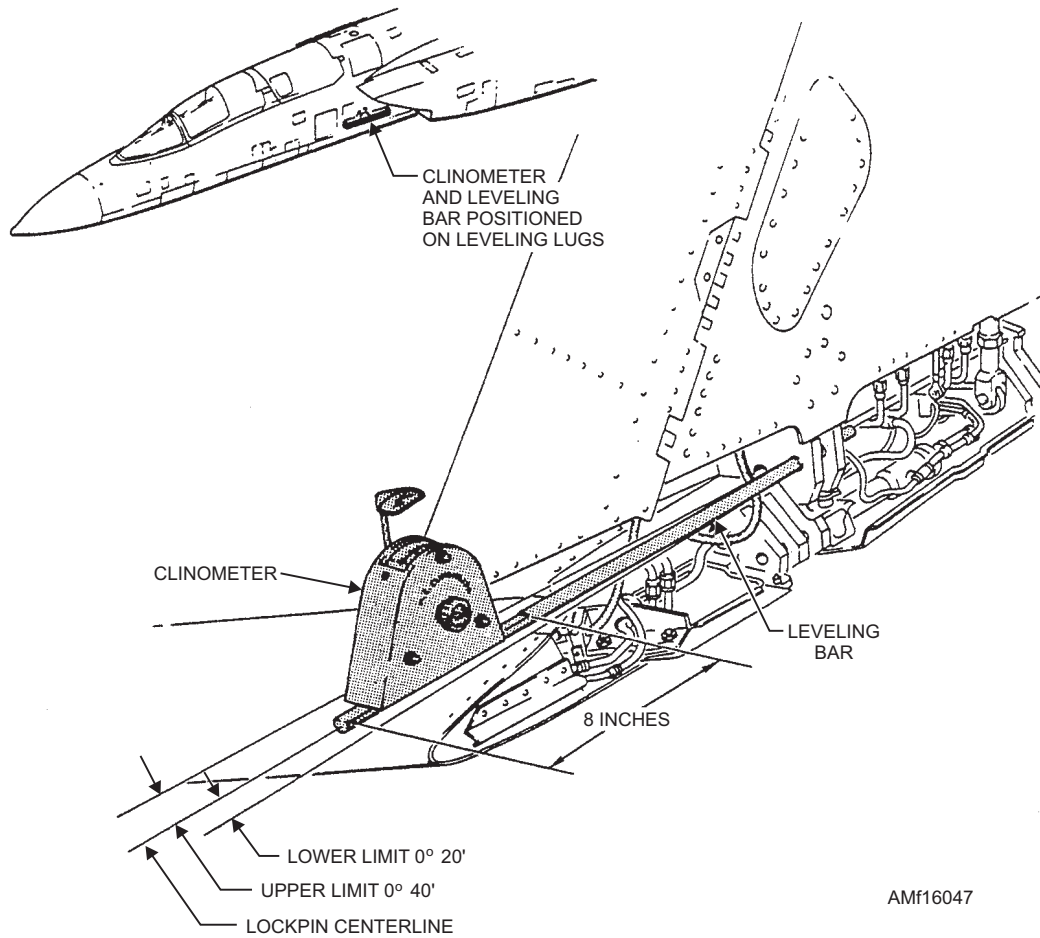

Figure 16-47.—Alignment data—wing twist check.

maintenance facility for a complete inspection and final disposition.

Q16-62. Why is the alignment of an airframe important?

Q16-63. How are flight control surfaces balanced at the time of manufacture?

Q16-64. What must be accomplished prior to performing an alignment check on an aircraft?

Q16-65. What is used to control the attitude of an aircraft during an alignment check?

Q16-66. How many different reference points are used during transit leveling?

Q16-67. When is an aircraft level when using the plumb bob method of leveling?

Q16-68. In what configuration must an aircraft be before a wing twist check can be performed?

ROTARY-WING FLIGHT CONTROL SYSTEMS

INTRODUCTION

The helicopter has become a vital part of naval aviation. The helicopter, known also as a rotary-wing aircraft, has many military applications. It has antisubmarine warfare (ASW) and search and rescue functions, as well as minesweeping and amphibious warfare functions. The advantages of the helicopter over conventional aircraft are that lift and control are relatively independent of forward speed. A helicopter can fly forward, backward, sideways, or remain in stationary flight above the ground (hover). Helicopters do not require runways for takeoffs or landings. The decks of small ships or open fields provide an adequate landing area.

ROTARY-WING THEORY OF FLIGHT

LEARNING OBJECTIVE: Recognize the principles of aerodynamics peculiar to the flight of rotary-wing aircraft.

The same basic aerodynamic principles apply to rotary-wing aircraft as fixed-wing aircraft. The main difference between the two types of aircraft is in the way lift occurs. The fixed-wing aircraft gets its lift from a fixed airfoil surface. The helicopter gets lift from rotating airfoils called rotor blades. The word *helicopter* comes from Greek words meaning *helical wing* or *rotating wing*. A helicopter uses one or more engine-driven rotors, from which it gets lift and propulsion.

The main rotor of a helicopter consists of two or more rotor blades. The airfoils of a helicopter are perfectly symmetrical. This means that the upper and lower surfaces are alike. This fact is one of the major differences between a fixed-wing aircraft's airfoil and the helicopter's airfoil. The airfoil on a fixed-wing aircraft has a greater camber on the upper surface than on the lower surface. The helicopter's airfoil camber is the same on both surfaces. See figure 17-1. Helicopters have symmetrical airfoils because the center of pressure across its surface should not move. On the fixed-wing airfoil, the center of pressure moves fore and aft, along the chord line. The center of pressure changes with changes in the angle of attack. If

this type of airfoil were on a rotary-wing aircraft, it would cause the rotor blades to jump around uncontrollably. With the symmetrical airfoil, this undesirable effect does not exist. The airfoil, when rotated, travels smoothly through the air.

Rotor lift can be explained by either of two theories. The first theory uses Newton's law of momentum. Lift results from accelerating a mass of air downward. This action is similar to jet thrust, which develops by accelerating a mass of air out the exhaust. The second theory is the blade element theory. The airflow over an airfoil section (blade element) of the rotor blade acts the same as it does on a fixed-wing aircraft. The simple momentum theory determines only the lift characteristic; while the blade element theory gives both lift and drag characteristics. This theory gives us a more complete picture of all the forces acting on a rotor blade.

Lift changes by increasing the angle of attack or pitch of the rotor blades. This action produces enough lift to raise the helicopter off the ground and keep it in the air. On a helicopter, when the rotor is turning and the blades are at zero angle of attack, no lift is developed. This feature provides the pilot with complete control of the lift developed by the rotor blades.

ROTOR AREA

One assumption made is that the lift depends upon the entire area of the rotor disc. The rotor disc area is

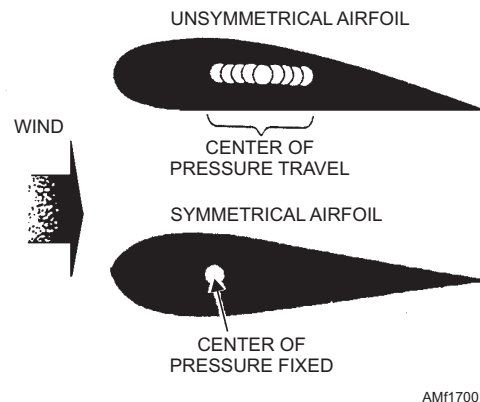

AMF17001

Figure 17-1.—Center of pressure.

the area of the circle, the radius of which is equal to the length of the rotor blade. Engineers determined that the lift of a rotor is in proportion to the square of the length of the rotor blades. The desirability of large rotor disc areas is readily apparent. However, the greater the rotor disc area, the greater the drag, which results in the need for greater power requirements.

PITCH OF ROTOR BLADES

If the rotor is operated at zero pitch (flat pitch), no lift will develop. When the pitch increases, the lifting force increases until the angle of attack reaches the stalling angle. To even out the lift distribution along the length of the rotor blade, it is common practice to twist the blade. With the twist, a smaller angle of attack results at the tip than at the hub.

SMOOTHNESS OF ROTOR BLADES

Tests have shown that the lift of a helicopter increases by polishing the rotor blades to a mirrorlike surface. By making the rotor blades as smooth as possible, the parasite drag reduces. Dirt, grease, or abrasions on the rotor blades cause increased drag, which decreases the lifting power of the helicopter.

DENSITY ALTITUDE

In formulas for lift and drag, the density of the air is an important factor. The mass or density of the air reacting in a downward direction causes the lift that supports the helicopter.

Density is dependent on two factors. One factor is altitude, since density varies from a maximum at sea level to a minimum at high altitude. The other factor is atmospheric changes. Because of the atmospheric changes in temperature, pressure, or humidity, density of the air may be different, even at the same altitude.

TORQUE

Although torque is not unique to helicopters, it does present some special problems. As the rotor turns in one direction, the fuselage rotates in the opposite direction. Newton's third law of motion (every action has an equal and opposite reaction) applies. This tendency for the fuselage to rotate is known as the torque effect. Since the torque effect on the fuselage is a direct result of engine power, any change in power changes the torque. The greater the engine power, the greater the torque. There is no torque when the rotary-wing head is not engaged or when the engine is not operating.

The usual method of counteracting torque in a single main rotor is by a tail (antitorque) rotor. This auxiliary rotor mounts vertically, or near vertical, on the outer portion of the tail boom. The tail rotor and its controls serve as a means to counteract torque, and it provides a means to control directional heading. See figure 17-2.

DISSYMMETRY OF LIFT

Dissymmetry of lift is the difference in lift existing between the advancing blade half of the disc and the retreating blade half. The disc area is the area swept by the rotating blades. Dissymmetry is created by horizontal flight or by the wind when the helicopter is hovering. When hovering in a no-wind condition, the speed of the relative wind in relation to the rotor is the same. However, the speed reduces at points closer to the rotor hub, as shown in figure 17-3. When the helicopter moves into forward flight, the relative wind moving over each blade becomes a combination of the rotor speed and the forward movement. The advancing blade is then the combined speed of the blade speed and helicopter speed. While on the opposite side, the retreating blade speed is the blade speed minus the speed of the helicopter. For example, figure 17-4 shows a helicopter moving forward at 100 mph. The advancing blade has a tip speed of 350 mph plus the helicopter speed of 100 mph, or 450 mph. The

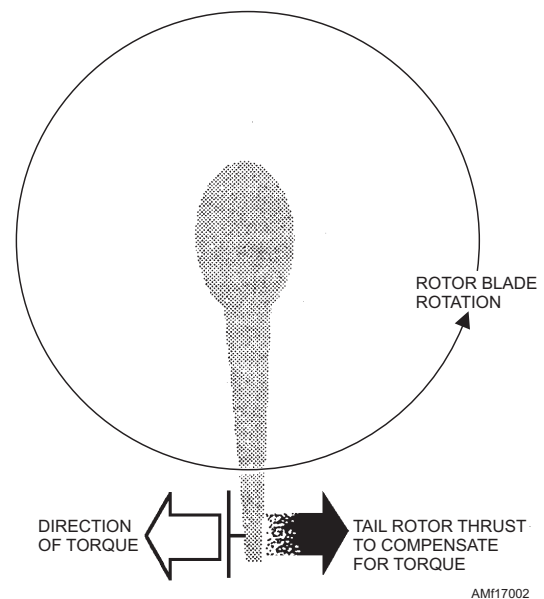

Figure 17-2.—Torque reaction.

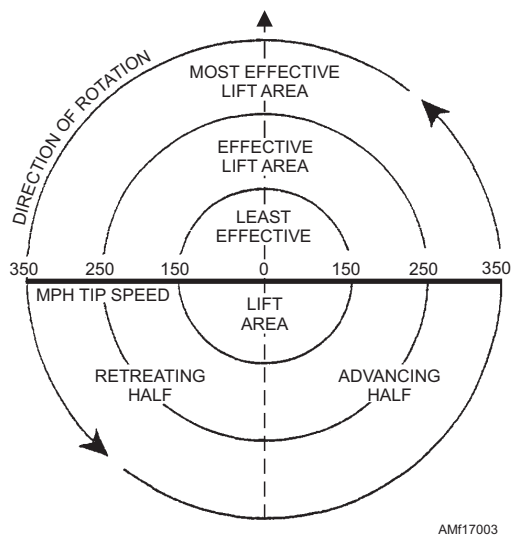

Figure 17-3.—Symmetry of lift.

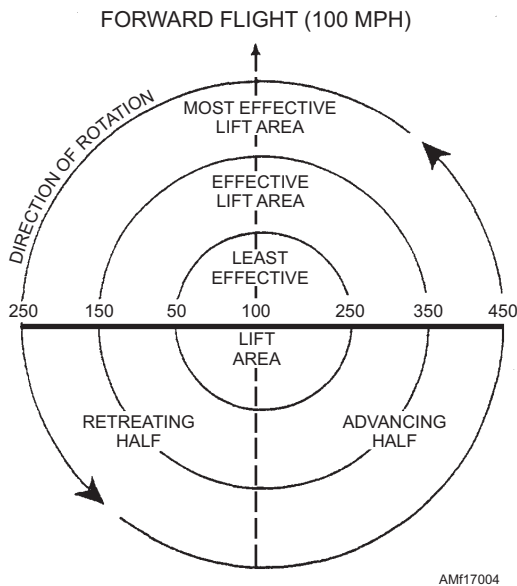

Figure 17-4.—Dissymmetry of lift.

retreating blade has a tip speed of 350 mph minus the helicopter's speed of 100 mph, or 250 mph. Hovering over one spot in a 20-mph headwind is the same as flying forward at a speed of 20 mph.

During forward flight or hovering in a wind, the lift over the advancing blade half of the rotor disc is greater than the retreating half. This greater lift would cause the helicopter to roll unless something equalized the lift. One method of equalizing the lift is through blade flapping.

BLADE FLAPPING

Blades attached to the rotor hub by horizontal hinges permit the blade to move vertically. The blades actually flap up and down as they rotate. The hinge permits an advancing blade to rise, thus reducing its effective lift area. It also allows a retreating blade to settle, which increases its effective lift area. Decreasing lift on the advancing blade and increasing lift on the retreating blade equalizes the lift over the rotor disc halves.

Blade flapping creates an unbalanced condition resulting in vibration. To prevent this vibration, a drag hinge allows the blades to move back and forth in a horizontal plane. A main rotor that permits individual movement of the blades in both a vertical and horizontal plane is known as an "articulated rotor."

CONING

Coning is the upward bending of the blades caused by the combined forces of lift and centrifugal force. Before takeoff, centrifugal force causes the blades to rotate in a plane nearly perpendicular to the rotor hub. During a vertical liftoff, the blades assume a conical path as a result of centrifugal force acting outward and lift acting upward. Coning causes rotor blades to bend up in a semirigid rotor. In an articulated rotor, the blades move to an upward angle through movement about the flapping hinges.

GYROSCOPIC PRECESSION

The spinning main rotor of a helicopter acts like a gyroscope. It has the properties of gyroscopic action, one of which is precession. Gyroscopic precession is the resulting action occurring 90 degrees from the applied force. A downward force to the right of the disc area will cause the rotor to tilt down in front. This action is true for a right-to-left (counterclockwise) turning rotor. The cyclic control applies force to the main rotor through the swashplate.

To simplify directional control, helicopters use a mechanical linkage that places cyclic pitch change 90 degrees ahead of the applied force. Moving the cyclic control forward will cause high pitch on the blades to the pilot's left. At the same time, low pitch occurs on the blades to his/her right. This combination of forces results in the rotor tilting down in front.

If not for this offset linkage, the pilot would have to move the cyclic stick 90 degrees out of phase. In other words, the pilot would have to move the stick to the

right when attempting to tilt the disc forward. He/she would move the cyclic stick forward when attempting to tilt the disc area to the left, and so on.

GROUND EFFECT

Ground effect can be achieved when a helicopter is in a hover or forward flight while in close proximity to the ground or some other hard flat surface. When a helicopter is in a hover or moving slowly, the main rotor is developing thrust that is being vectored, or directed down toward the surface. The surface resists this airflow (thrust) by building up air pressure between the rotor and the surface, thus providing ground cushion. When the helicopter is in forward flight, the cushion is not as great as the thrust that is being vectored down and aft of the helicopter. This ground cushion will provide additional lift without additional power, and will be apparent when the helicopter is hovering or flying at an altitude of approximately one-half the main rotor diameter or below. The closer the helicopter is to the ground, the greater the cushion effect. This will be indicated by the reduced power required to maintain flight or hover. The maximum cushion effect is achieved at zero airspeed.

TRANSLATIONAL LIFT

As a helicopter begins the transition from a hover to forward flight, at approximately 10-15 knots, it will experience a loss of lift and settle slightly and seem to lose power, without an actual reduction in power. This is due to the loss of the ground cushion caused by the changing direction or vector of the rotor's thrust. As the helicopter continues to accelerate, the rotor will be introduced to larger masses of air. The rotor will become more efficient and the thrust vector of the rotor will become more stable. Without increasing power (thrust), the helicopter will begin to climb and continue to accelerate. This changing relationship of power (thrust) available and power required is called "translational lift." The speed that a helicopter passes out of translational lift into forward flight can vary, but generally, it is equal to approximately one-half the rotor diameter in knots, or approximately 25 knots for a 50-foot diameter rotor.

AUTOROTATION

Autorotation occurs when the main rotor rotates by air passing up through the rotor system instead of by the engine. The rotor disengages automatically from the engine during engine failure or shutdown. During

autorotation, the rotor blades turn in the same direction as when engine driven. The air passes up through the rotor system instead of down. This action causes a slightly greater upward flex or coning of the blades.

POWER SETTLING

Stalling, as applied to fixed-wing aircraft, will not occur in helicopters. However, power settling may occur in low-speed flight. Power settling is the uncontrollable loss of altitude. This condition may occur due to combinations of heavy gross weights, poor density conditions, and low forward speed. During low forward speed and high rates of descents, the downwash from the rotor begins to recirculate. The downwash moves up, around, and back down through the effective outer disc area. The velocity of this recirculating air mass may become so high that full collective pitch cannot retard or control the rate of descent.

- Q17-1. What produces the lift required for helicopter flight?*
- Q17-2. When the camber is the same on both surfaces of an airfoil and results in a fixed center of pressure, what term describes the helicopter airfoil?*
- Q17-3. What determines the amount of lift generated by a helicopter's rotor?*
- Q17-4. What is the result of highly polished rotor blades?*
- Q17-5. Where is density altitude at its greatest?*
- Q17-6. On a single main rotor helicopter, the tail rotor is used to counteract what force?*
- Q17-7. Other than horizontal flight, how is rotor blade dissymmetry created?*
- Q17-8. What type of main rotor allows individual rotor blades to move in both a vertical and horizontal plane to reduce vibration caused by blade flapping?*
- Q17-9. The upward bending of rotor blades is known by what term?*
- Q17-10. When a helicopter is close to the ground, will it require more or less power to maintain a hover?*
- Q17-11. What term refers to main rotor rotation caused by air passing through the main rotor blades instead of being powered by the engine?*

Q17-12. What term describes the effect that occurs when a helicopter experiences an uncontrollable loss of altitude because of a combination of heavy gross weight, poor density conditions, and low forward speed?

TYPES OF HELICOPTERS

LEARNING OBJECTIVE: Identify the two basic types of helicopters. Recognize the advantages of each type.

Two basic types of helicopters are the single-rotor and multirotor types. The single main rotor with a vertical or near vertical tail rotor is the most common type of helicopter. The SH-60 and SH-2, shown in figure 17-5, are examples of single-rotor helicopters. Multirotor helicopters fall into different groups according to their rotor configuration. The CH-46, shown in figure 17-5, is a multirotor helicopter of the tandem rotor design.

The single-rotor configuration requires the use of a vertical tail rotor to counteract torque and provide directional control. The advantages of this configuration are simplicity in design and effective directional control. In the tandem rotor design, one rotor is forward of the other. Sometimes the rotor blades are in the same plane. They may or may not intermesh. The design offers good longitudinal stability since lift occurs at two points, fore and aft. The tandem rotor has little torque to overcome because these rotors rotate in opposite directions.

Q17-13. What is the most common type of helicopter?

Q17-14. The CH-46 multirotor helicopter has what type of rotor design?

Q17-15. What feature provides the single rotor configuration with excellent directional control?

Q17-16. In what direction does a tandem rotor operate that results in little torque?

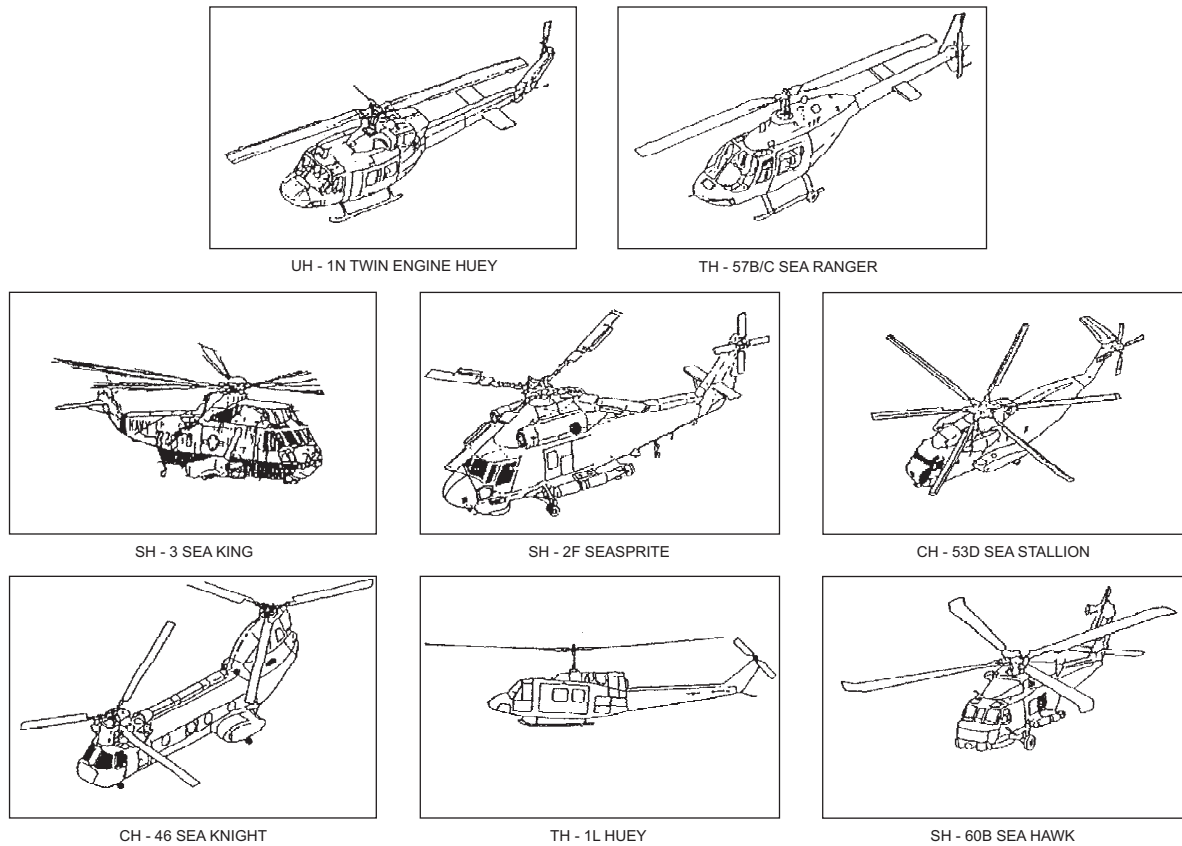

AM17005

Figure 17-5.—Representative types of naval helicopters.

HELICOPTER FLIGHT CONTROLS

LEARNING OBJECTIVE: Identify the three primary flight controls and the basic control systems components.

Helicopter flight controls differ drastically from those found in fixed-wing aircraft. Helicopter flight controls consist of both cyclic and collective pitch control systems and the rotary rudder flight control system.

The hydraulically powered flight control mechanism, shown in figure 17-6, provides you with an example of systems common to most helicopters. These are the systems on which you will most likely be working. Fairly exact values, such as tolerances, pressures, and temperatures, are given to provide instructive coverage. When actually performing the maintenance procedures, consult the current technical publications for the latest information and exact values.

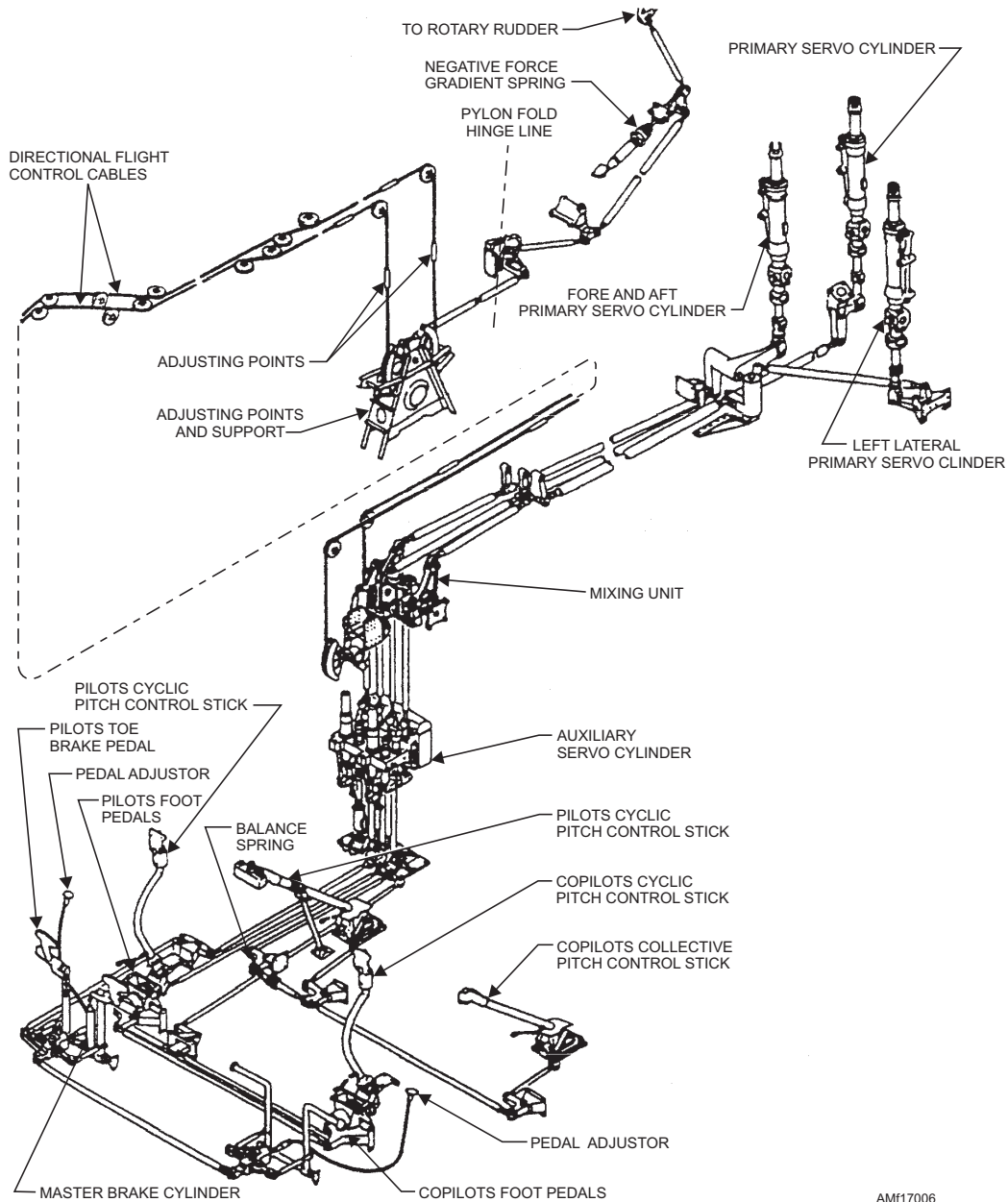

AMF17006

Figure 17-6.—Flight control systems.

CYCLIC PITCH CONTROL SYSTEM

The cyclic pitch control system provides the means of controlling the forward, aft, and lateral movements of the helicopter. Movement of the pilot's or copilot's cyclic stick transmits through control rods and bell cranks. This movement is sent to the auxiliary servo cylinders, the mixing unit, and three primary servo cylinders. These primary servo cylinders control movement of the rotary-wing blades.

The cyclic system has a stick trim system that hydraulically operates the controls for automatic flight. During automatic flight, trim movements are controlled manually by the cyclic stick grip switch. The switch is overridden for major control changes by stick movement.

Moving the cyclic stick forward extends the aft primary servo cylinder and retracts the forward primary servo cylinder. Aft movement of the cyclic stick extends the forward primary servo cylinder and retracts the aft primary servo cylinder. In both cases, the helicopter will advance in the direction of stick movement. Movement of the stick laterally will move the helicopter right or left, corresponding with stick movement. This movement occurs by retracting and extending the left and right lateral primary servo cylinders.

COLLECTIVE PITCH CONTROL SYSTEM

The collective pitch control system provides vertical control of the helicopter. Movement of the collective pitch control stick is sent through control rods and bell cranks to the appropriate auxiliary servo cylinder. Movement is sent from the servo cylinder to the mixing unit. At the mixing unit, all vertical movements of the collective sticks are sent to the primary servo cylinders and the rotary-wing swashplate. At this point, the pitch of all blades increases or decreases equally and simultaneously. A balancing spring attaches to the control rods to help balance the weight of the collective stick. A friction lock on the pilot's collective stick applies the desired amount of friction to the tube of the collective stick. The lock prevents creeping during flight. It also provides feel for the pilot when operating the controls. The friction is applied by rotating the serrated handgrip on the collective stick to its stop.

The grip of each collective stick contains several switches that are labeled for the function they control.

In the automatic stabilization equipment (ASE) mode operation, the collective pitch operation controls through the auxiliary servo cylinder.

ROTARY RUDDER CONTROL SYSTEM

The rotary rudder control system controls the pitch of the rotary rudder blades. The blades control the heading of the helicopter. The pedals control the system through a series of control rods and bell cranks. These units connect to the directional bank of the auxiliary servo cylinder and the mixing unit. See figure 17-6. At the mixing unit, a control rod operates the forward quadrant. This quadrant connects by cable to the aft quadrant. A control rod from the rear quadrant connects to the control rods, bell crank, and pitch control shaft. These parts are found in the rotary rudder tail gearbox. A hydraulic pedal damper is located in the auxiliary servo cylinder bank (directional). Its purpose is to prevent sudden movements of the control pedals. The damper prevents rapid changes in blade pitch, which might cause damage to the helicopter. As on conventional aircraft, the rudder pedals are adjustable for different leg lengths. The rotary rudder system operates by manual input or automatically by input from the ASE.

The negative force gradient spring cancels feedback loads exerted by the rotary rudder during flight. It also cancels feedback loads when the auxiliary hydraulic system is off. When the rotary rudder is stationary, an initial force is required to move either pedal from its extreme position. With the auxiliary hydraulic system on, the effect of the negative force gradient spring is zero.

WARNING

The negative force gradient spring is preloaded to 600 pounds. To prevent injury to personnel or damage to flight controls, carefully follow the maintenance instructions provided in the MIM.

FLIGHT CONTROL SYSTEMS COMPONENTS

The basic components of the helicopter flight control systems are the auxiliary servo cylinder, the mixing unit, the primary servo cylinders, and the swashplate.

Auxiliary Servo Cylinder

This cylinder consists of four separate banks of servomechanisms constructed as a unit. Figure 17-7 shows the fore-and-aft bank of the servo cylinder. The other banks are similar in design and operation.

The hydraulic power pistons of each bank help flight control movements before the movement is sent to the mixing unit. The cylinder operates on mechanical input during manual operation of the flight controls. The cylinder operates on electrical input from the ASE, and on electrical input from the stick trim system.

Each of the four banks operates in a single area of control functioning, providing fore-and-aft, lateral, collective, and directional hydraulic aid. Each bank has a mechanical and electrical input hydraulic servo valve capable of displacing the pilot valve shuttle for ASE operation. Additionally, the fore-and-aft and the lateral banks have a pair of solenoid-operated stick trim valves. These valves control fore, aft, and lateral movements through the stick trim system.

The directional bank uses a pedal damping piston that restricts sudden heading changes. The auxiliary servo cylinder operates at 1,500-psi hydraulic pressure supplied by the auxiliary hydraulic system.

Mixing Unit

The mixing unit consists of a system of bell cranks and linkage. The unit coordinates and transfers independent movements of the lateral, forward, aft, and directional controls. Movement is sent to the primary servo cylinders and the rotary rudder. The mixing unit also integrates collective pitch control movements with those of the lateral, fore-and-aft, and directional systems. It causes the controls to move the three primary servo cylinders simultaneously in the same direction. It changes the pitch on the rotary rudder blades to compensate for the change in pitch of the rotary-wing blades.

Primary Servo Cylinders

These three servo cylinders send flight control movements to the stationary washplate of the rotary-wing head. If the primary hydraulic system is operating, the servo cylinders hydraulically aid flight control movement. If the power fails, they function only as control rods. See figure 17-8. This is accomplished by the spring-loaded bypass valve, which prevents hydraulic lock and a sloppy link pilot valve connection. The pilot valve and the lower clevis of the power piston connect to the flight control linkage by the same bolt. There is a very close tolerance in the pilot valve connection. This tolerance causes the pilot

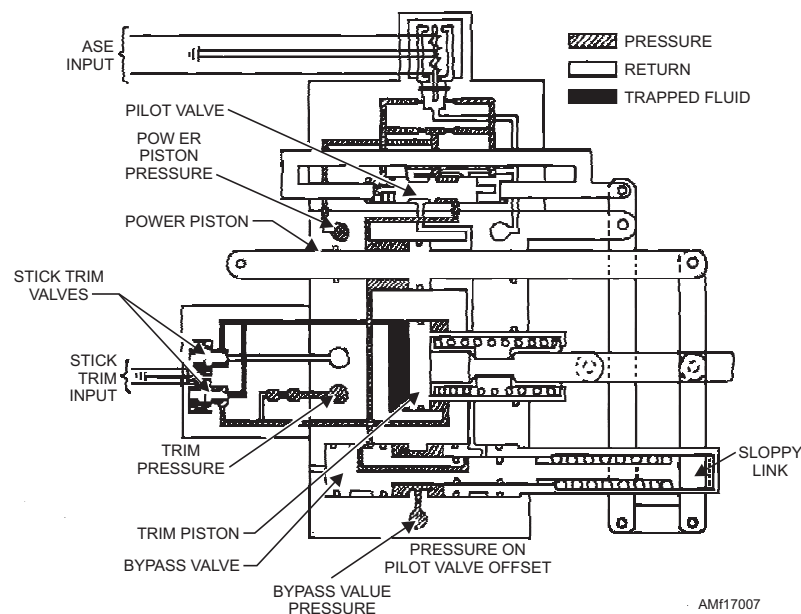
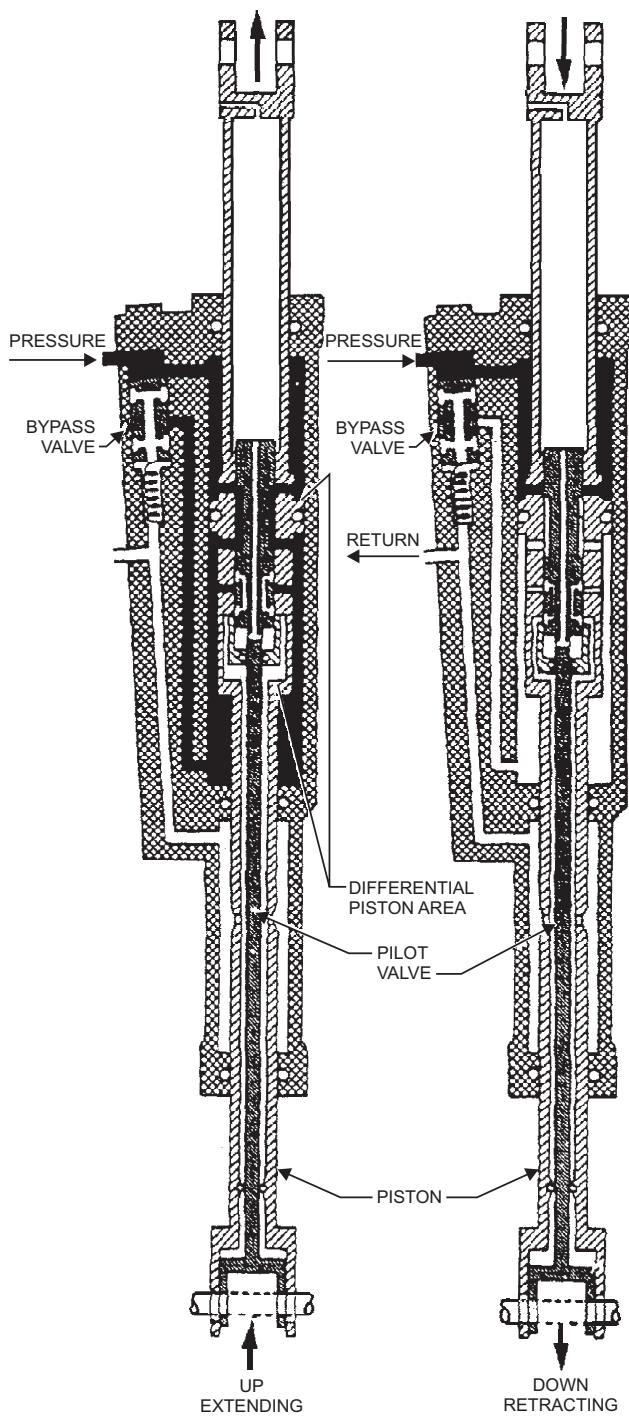

Figure 17-7.—Auxiliary servo cylinder.



AMf17008

Figure 17-8.—Primary servo cylinder.

valve to operate before the power piston clevis. The power piston is then mechanically displaced.

Fluid under pressure entering the servo cylinder upper port closes the bypass valve and enters the upper chamber. With the pilot valve in neutral, fluid cannot escape from the lower chamber, and the piston remains motionless. If the pilot valve moves upward, fluid

flows into the lower chamber. The piston will rise because of a pressure area differential. If the pilot valve moves down, the fluid in the lower chamber flows to return. The piston will be forced downward by upper chamber pressure.

When flight control movements stop, the piston will continue to move until the ports of the pilot valve

close. The pilot valve clevis will be in the center of the sloppy link. When pressure is off, the bypass valve will open, preventing hydraulic lock.

Swashplate Assembly

The swashplate assembly, shown in figure 17-9, sends movement of the flight controls to the rotary-wing blades. A ball ring and socket allows the swashplate to tilt off its horizontal plane and move on its vertical axis.

The assembly consists of a rotating swashplate, connected to the rotary-wing hub by the rotating scissors and adjustable pitch control rods. The assembly also has a stationary swashplate, which connects to the main gearbox by the stationary scissors and the primary servo cylinders. Each swashplate assembly is bolted together in a way that permits the rotating swashplate to rotate within the stationary swashplate. When the primary servo cylinders are actuated by the flight controls, the stationary swashplate moves, with this movement being transmitted to the rotating swashplate. The rotating swashplate sends movement, through the adjustable pitch control rods, to the sleeve spindle of the rotary blades. This action changes the angle of incidence of the blades.

- Q17-17. What pitch control system provides lateral helicopter movement?*
- Q17-18. What pitch control system provides vertical helicopter movement?*
- Q17-19. What does the rotary rudder system control?*
- Q17-20. On the rotary rudder control system, what component is preloaded to 600 pounds and considered hazardous to personnel?*
- Q17-21. How many separate banks of servomechanisms make up the auxiliary servo cylinder?*
- Q17-22. What component controls and transfers independent movements of the lateral, forward, aft, and directional controls?*
- Q17-23. The movement of what valve allows hydraulic fluid flow in the three primary servo cylinders?*
- Q17-24. What unit sends movement, through the adjustable pitch control rods, to the sleeve and spindle assembly of the rotary blades to change the angle of incidence of the blades?*

ROTARY-WING MAINTENANCE

LEARNING OBJECTIVE: Identify general rotary-wing maintenance procedures to include system rigging and rotor blade tracking.

Organizational maintenance of the helicopter flight control system includes periodic inspection, lubrication, rigging, and blade tracking. It also includes the cleaning of the rotary-wing and rudder blades and the removal and replacement of malfunctioning components.

Organizational maintenance of the auxiliary and primary servo cylinders is limited to minor adjustment and replacement of miscellaneous seals. Organizational maintenance includes the removal and installation of the complete component. Major adjustments made on servo cylinders during overhaul are critical. These adjustments are not made at the lower levels of maintenance.

Vibrations and cyclic actions inherent to helicopters can cause component or structural fatigue. Nondestructive testing (NDI) is used on many parts of the airframe and many dynamic components to detect flaws (cracks) that could lead to failure. Additionally, most of the dynamic components, such as rotor heads, blades, servo cylinders, and swashplates, have forced (high-time) removal intervals. These time intervals are listed by component in the Periodic Maintenance Information Cards (PMIC) for the aircraft.

You should clean the rotary wing and rotary rudder as necessary, using only approved cleaners. The concentration of mixture will vary, depending on the surface condition and type of cleaner used.

CAUTION

Both the rotary-wing and rudder blades have areas that connect by bonding adhesives or they are manufactured out of fiber glass or advanced composite materials. Never use solvents or cleaners not specifically authorized in the MIM. Do not use lacquer thinner, naphtha, carbon tetrachloride, or other organic compounds for cleaning in these bonded areas. Use of these solvents or cleaners may result in blade failure.

SYSTEM RIGGING

Rigging checks and adjustments involve the cyclic pitch control stick, collective pitch control stick, and pedal positions. These controls must coordinate with

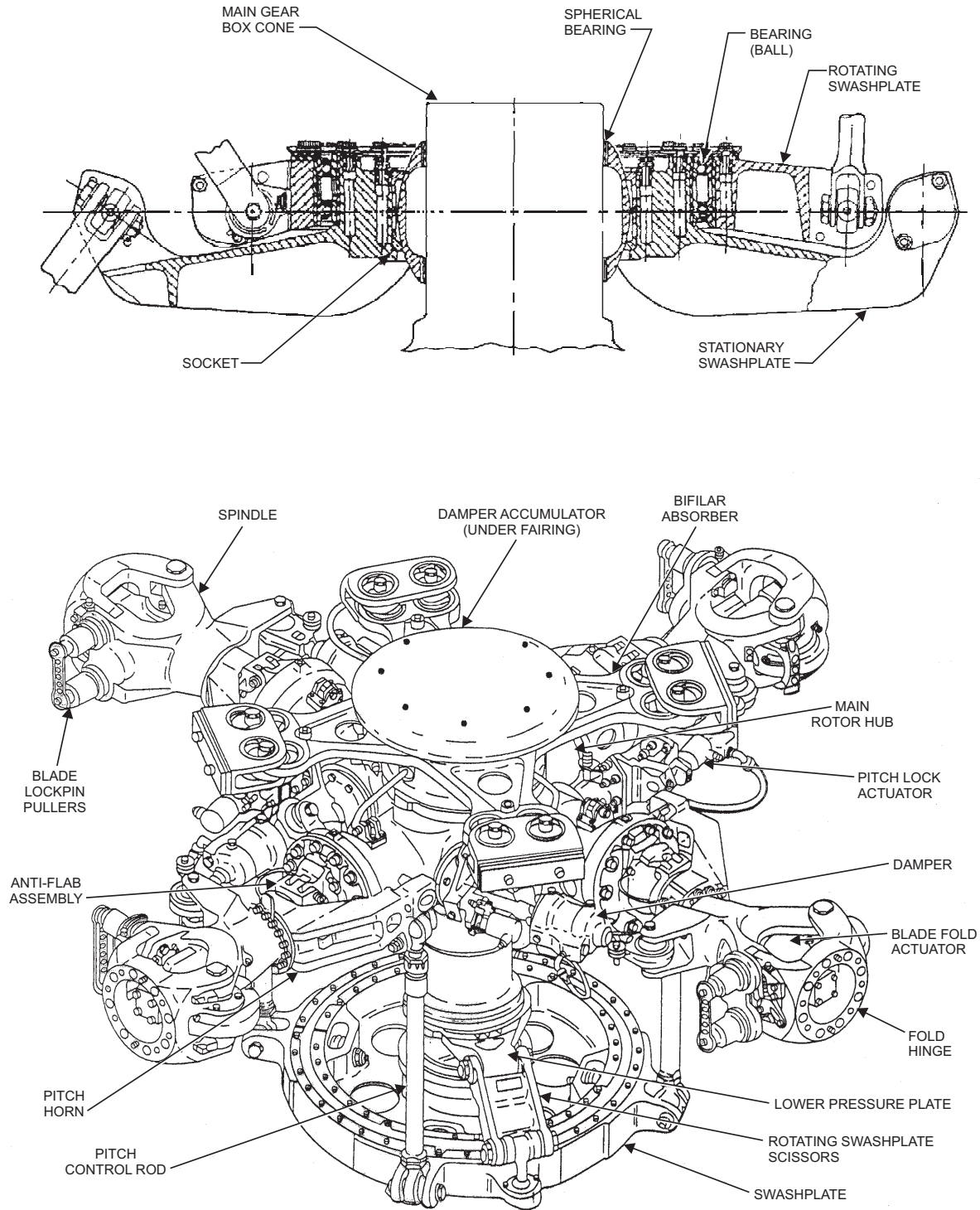

AMf17009

Figure 17-9.—Swashplate—cross-sectional and installed view.

the correct rotary-wing and rotary-rudder blade angles. You must be sure that the flight controls are operating under normal friction loads.

The use of rigging pins and other rigging aids provide proper rigging and proper system operation. Each step outlined in the MIM should be carefully performed.

Several quick rigging, cable adjustment, and operational checks with related maintenance precautions are found in the MIM. No attempt to duplicate this information is provided in this chapter. The MIM should be consulted before any maintenance begins.

At the completion of rigging, a flight test must be performed by a qualified pilot. A flight check chart is provided by the MIM. The MIM lists the conditions of the check, the required performance, and information to aid in the correction of malfunctions.

ROTOR BLADE TRACKING

You must perform blade tracking when rerigging the helicopter. Tracking is necessary when the blades, the main gearbox, or the main rotor head assembly have been replaced. Unless the blades are in proper track, vibrations will occur in the helicopter with every revolution of the main rotor. At high rpm settings, these vibrations could cause serious structural damage.

Tracking the blades is necessary to be sure that the blades rotate in the same horizontal plane (track). This is accomplished by pretrack rigging of the rotary-wing head and by the use of pretracked blades.

Pretrack rigging involves adjusting the pitch control rods until an exact sleeve angle (within 1 minute) is found on all sleeve spindles. A micrometer type of decal is affixed to the adjustable pitch control rods as a permanent reference at the overhaul activity. A pretrack number is stenciled on each blade at the time of manufacture or overhaul. This number is based on the effective angle of the blade. Install pretracked blades on the helicopter by setting the adjustable pitch control rod to the pretrack number stenciled on the blade.

If the pretrack number is MINUS and the pitch control rod decal shows the setting is zero, loosen the locknut. Shorten the rod by rotating the tang clockwise. Keep rotating until it aligns (closest notch) with the appropriate blade pretrack number on the lower scale of the lower decal. Engage the tang by tightening the locknut. If the pretrack number of the

blade is PLUS and the pitch control rod decal shows the setting is zero, loosen the locknut. Lengthen the rod by rotating the tang counterclockwise. Keep rotating the tang until it aligns (closest notch) with the appropriate blade pretrack number on the upper scale of the lower decal. After adjusting the remainder of the pitch control rods, tighten the locknuts to the torque specified in the MIMs. Safety wire the locknuts to the tang.

You should perform a ground operational check. With the rotary-wing head engaged, operate the engines at 100 percent. Check for vibrations in the rotary-wing head. If vibrations occur and the adjustable pitch control rods were properly adjusted, use an alternate method of blade tracking. In this case, use a strobe blade tracker to check the blades under actual operating conditions. You must be sure that all blades are rotating in the same horizontal plane. See figure 17-10. Pitch adjustment of each blade may be made to compensate for blade differences.

The Strobex blade tracker permits tracking from inside the helicopter in flight or on the ground. The system uses a highly concentrated stroboscopic light beam flashing in sequence with rotation of the rotary-wing blades, so that a fixed target at the blade tips will appear to be stopped. A soft iron sweep attached to the rotating swashplate passes close to a magnetic pickup attached to the stationary swashplate, causing a once-per-revolution pulse, which synchronizes the lamp flash rate with the rotation of the blades. Each blade has a retroreflective target number attached to the underside of the blade in a uniform location. Tracking of each blade is then determined by the relative vertical position of the fixed target numbers. See figure 17-10. Consult the applicable aircraft MIMs for the proper operating procedures for the Strobex blade tracker. For maintenance information on the Strobex tracker, refer to NAVAIR 17-15BBA-4.

NOTE: Do not adjust blades by the Strobex method of blade tracking unless problems result from normal tracking procedures.

ROTOR BRAKE SYSTEM

As a part of the blade folding operation, the rotor brake applies manually or automatically. The system is shown in figure 17-11. It consists of a rotor brake assembly, panel package, accumulator, master cylinder, pressure gauge, check valves, and pressure switches.

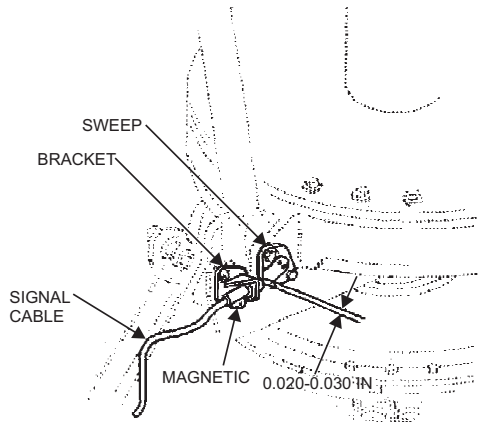
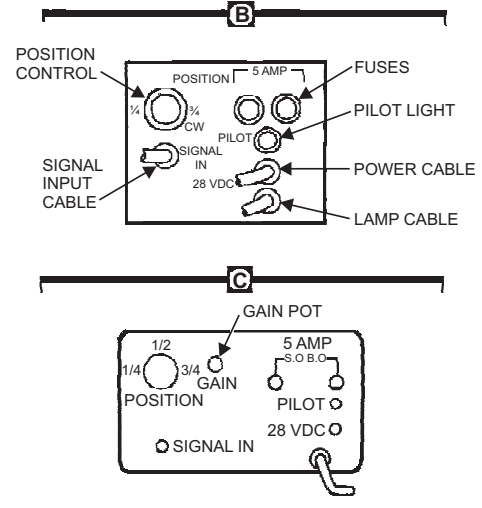
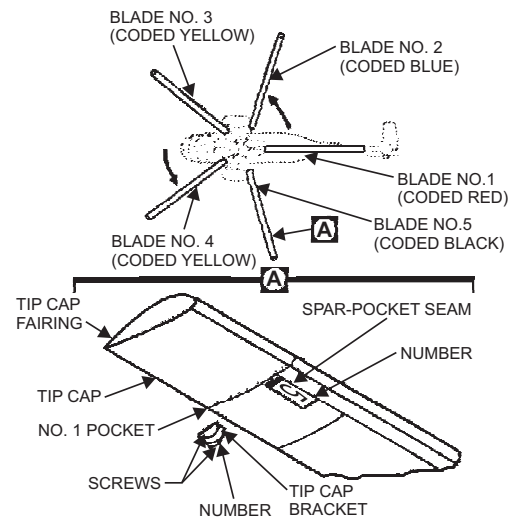
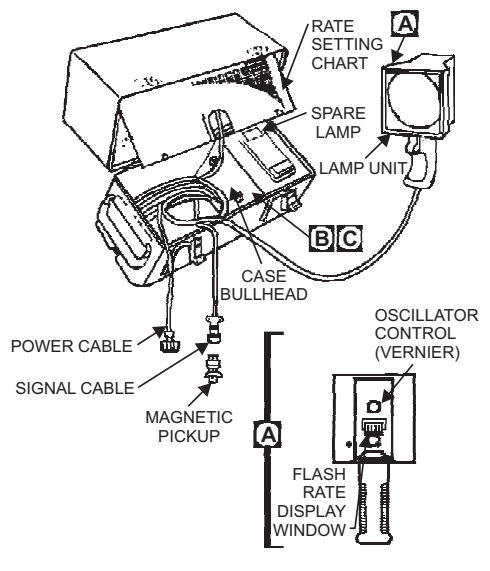
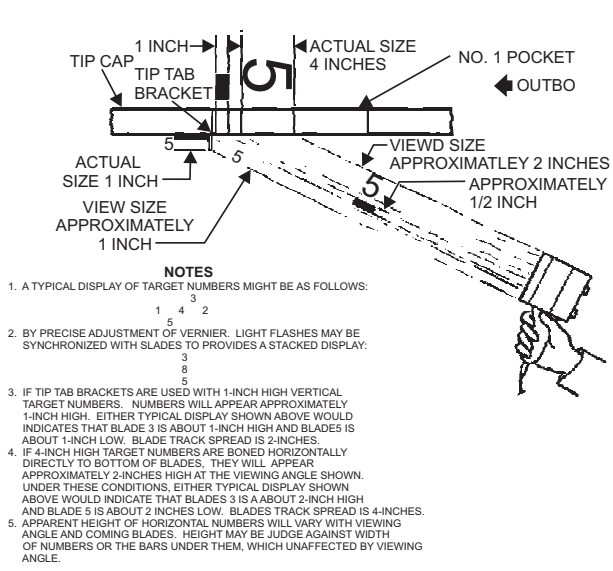

Amf17010

Figure 17-10.—Blade tracking—Strobex.

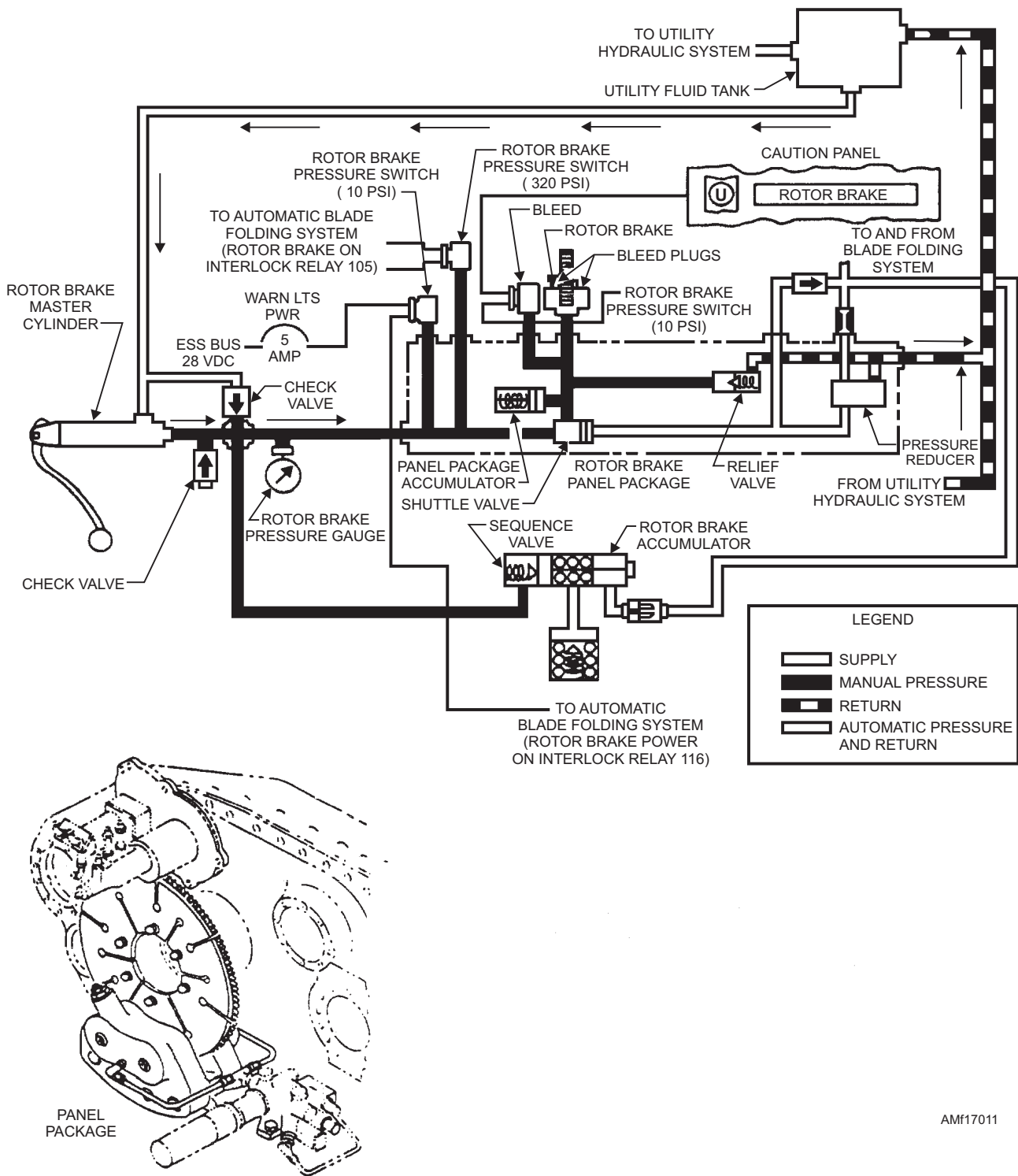

Figure 17-11.—Rotor brake and system schematic.

Rotor Brake Assembly

The rotor brake assembly is comparable to the single disc wheel brake in its design and operation. Hydraulic actuation of the brake may be made manually by using the rotor brake master cylinder located in the cockpit. The brake applies automatically during the blade folding operation by the blade positioner control valve. In manual operation, the brake is capable of stopping the rotary-wing head in 14 seconds from 157 rpm. Replace the brake linings when any of the adjusting pins recede into the adjusting nut 1/8 inch. Replace lock screws and worn parts each time linings are replaced.

Rotor Brake Panel Package

This package consists of an accumulator, relief valve, pressure reducer, and a shuttle valve. The package receives hydraulic pressure from the master brake cylinder during manual operation. It receives pressure from the automatic blade folding system during automatic operation. When the master brake cylinder handle is in the OFF or DETENT position, the master cylinder vents to the utility fluid tank. Movement of the master brake cylinder handle blocks the vent and builds up brake pressure. When the pressure increases beyond 200 psi, the shuttle valve in the panel package shifts. Pressure is sent to the rotor brake and blocks pressure from the automatic blade folding system. The panel package accumulator reduces minor pressure surges during manual and automatic operation. The accumulator maintains a steady pressure to the brake. The relief valve relieves pressure surges in excess of 600 psi.

Rotor Brake Accumulator

The spring-loaded rotor brake accumulator permits manual operation of the master cylinder handle during automatic blade folding operations. Applying the automatic brake unseats the accumulator sequence valve. The open valve permits actuation of the master cylinder handle. The hydraulic fluid flows through the sequence valve and compresses the accumulator spring. Releasing the automatic brake causes pressure to flow from the accumulator to the panel package shuttle valve, and repositions it. Simultaneously, the panel package accumulator maintains hydraulic pressure that was trapped from the automatic application in the rotor brake. The rotor brake accumulator additionally compensates for

thermal expansion and contraction of the fluid, and aids in dampening pressure surges.

Rotor Brake Master Cylinder

The master cylinder is gravity fed by hydraulic fluid from the utility fluid tank. Move the brake handle down and forward to apply pressure to the system. A spring latch on the cylinder linkage automatically locks the handle in the ON or PARK position. To release the brake, pull the latch and place the handle in the DETENT position. The pressure gauge indicates the amount of pressure produced by the master brake cylinder. The check valve provides a means to pressure bleed the system. A minimum pressure of 320 psi is required to effectively operate the rotor brake.

AUTOMATIC BLADE FOLDING SYSTEM

An automatic blade folding system of a representative helicopter is shown in figure 17-12. This system is capable of automatic blade folding of one of the two rotary blades from cockpit controls.

Blade Folding Operations

The No. 1 blade does not fold, but it automatically positions over the tail pylon. The only hydraulic actuation of the No. 1 blade is damper positioning. The hydraulic portion of the system positions the blades and folds the No. 2 blade. The electrical portion of the system provides the sequencing of operation of the various hydraulic components. It acts to prevent accidental operation of the system. Warning and indicating lights show the status of the system at all times. Safe operation is maintained by a series of electrical interlocks.

You should perform blade-folding operations with the pylon locked in the flight position and the engine operating at 104 percent. The rotary-wing head must not be operating. The accessory drive switch is placed in ACCESS DRIVE. The safety valve switch is placed OPEN, and the master switch is placed ON. The blade switch is placed in the FOLD position.

Hydraulic pressure from the utility hydraulic system is 3,000 psi. The pressure flows through the motor-operated safety valve. This pressure flows to the blade positioner control valve, and is sent to the blade positioner drive unit for engagement with the rotor brake disc. This action turns the rotary-wing shaft.

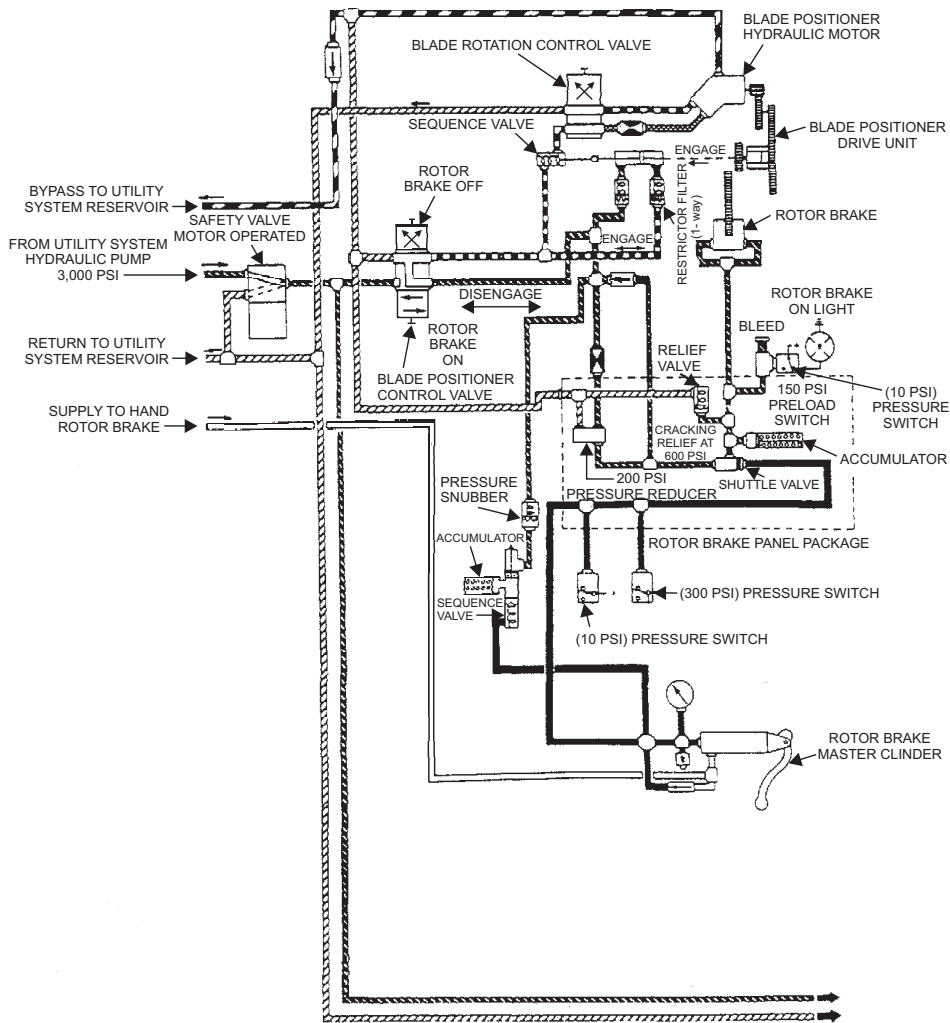

AM17012

Figure 17-12.—Automatic blade folding system schematic.

Pressure is sent through the blade rotation control valve to the blade positioner hydraulic motor. The motor revolves the blade positioner, causing the rotation of the rotary-wing head. When the No. 1 blade is properly positioned aft, the blade positioner control valve is energized in the opposite direction. The action stops positioning and disengaging of the blade positioner drive unit. Fluid is also sent to engage the rotor brake at this time.

On later models, the rotor brake applies manually. The blade fold control valve is energized, sending hydraulic pressure through the rotor coupling to each damper-positioner. The blades move against their autorotative stops. The mechanical action of

positioning the blades operates the damper-positioner sequence valves. These valves cause hydraulic fluid to operate the control lock cylinder, locking the controls. With the rotor head controls locked, pressure is sent to the blade fold lock cylinder. The lockpin is retracted, and fluid is sent to the blade fold cylinder.

The blade fold cylinder is found inside the sleeve spindle of the No. 2 blade. See figure 17-13. It connects to sector gears, which cause the folding actions. When the No. 2 blade reaches a certain angle, a microswitch turns on the blade folded light in the cockpit. The lock valve traps hydraulic fluid in the rotary-wing head to keep the damper-positioners in the

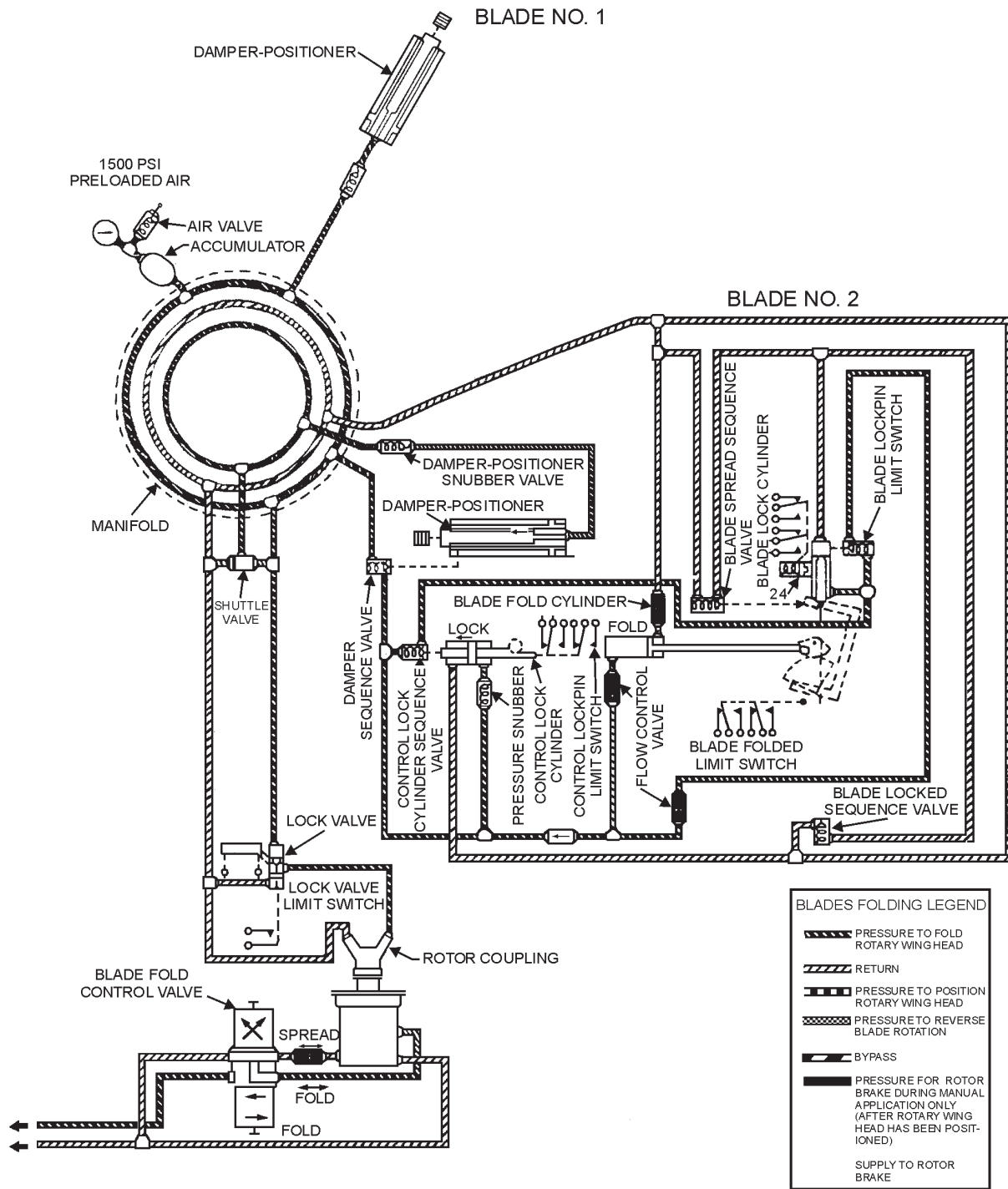

AM17012 (CONT.)

Figure 17-12.—Automatic blade folding system schematic—Continued.

autorotative position. It also keeps the No. 2 blade in the folded position.

With the fold sequence completed, the SAFETY VALVE OPEN, the FOLD PWR ON, the No. 1

BLADE POS, the CONT LOCKPIN ADV, and the BLADES FOLDED warning and indicating lights are lit.

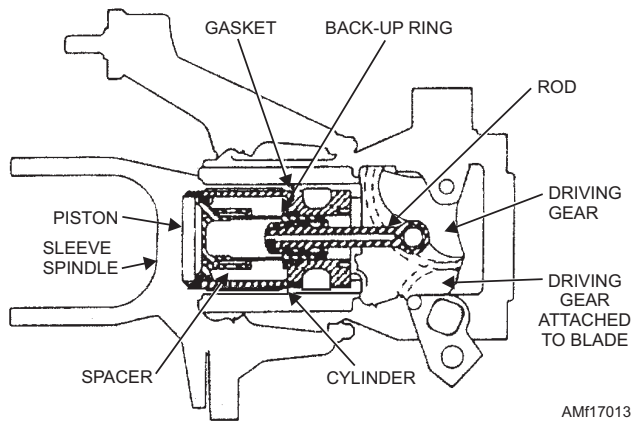

Figure 17-13.—Blade fold cylinder.

NOTE: You may have to move the cyclic control stick around the neutral position to engage the control lockpin. If excessive movement of the cyclic stick is necessary, troubleshoot the system for possible maladjustment.

Blade Spreading Operations

The spreading operation requires the same conditions as the fold operation. The primary exception is that the blade fold switch is in the SPREAD position. Pressure is sent through the motor-operated safety valve and through the positioning unit pressure reducers. Pressure is sent to the blade positioner drive unit for rotor brake disc disengagement and the engagement of the rotor brake.

With the rotor brake on and the blade fold valve energized, 3,000-psi hydraulic fluid is sent through the rotor coupling. From the coupling, pressure is sent to the damper-positioners. The damper-positioners drive the blades against their autorotative stops. Pressure is then sent to the blade fold cylinder. The blade fold cylinder operates the gear sector and spreads the blade. As the blade starts to spread, the lock valve solenoid is de-energized, releasing fluid in the rotary-wing head.

When the blade is completely spread, hydraulic fluid is sent to the blade lock cylinder, engaging the blade lockpin. Engagement and locking of the blade lockpin causes the internal sequencing mechanisms to direct pressure to the control lock cylinder. The control lock cylinder, in turn, locks the controls. The spread sequence is completed. The FOLD PWR, BLADE SPREAD, and SAFETY VALVE OPEN warning and indicating lights should be lit.

Blade Folding System Components

Hydraulic components of the blade folding system are conventional type, solenoid-operated selector valves, check valves, pressure reducers and snubber, sequence valves, and actuating cylinders. Of special interest are the safety valve, the blade positioner drive unit, the rotor coupling, the control lock cylinder, and the blade fold accumulator.

SAFETY VALVE.—The safety valve is a two-position, motor-operated selector valve. The purpose of the unit is to prevent hydraulic pressure from entering the blade fold system during flight. The motor provides a camming action to move the poppet valve within the selector valve. With the rotor stopped, electrical interlocks allow the safety valve to send fluid to the blade folding system. This action occurs when the safety valve switch is placed in the OPEN position. In the CLOSED position, pressure is blocked at the pressure port. The system vents through the lock valve. The venting eliminates the possibility of damage to the system by thermal expansion of the hydraulic fluid. The safety valve will not close if the blade spread interlock relay malfunctions. The safety valve will not close if the blades are folded. The safety valve motor opens a limit switch. The switch cuts electrical power to the motor when the safety valve reaches the fully open position.

BLADE POSITIONER DRIVE UNIT.—The drive unit is found on the upper surface of the main gearbox input cover. It consists of a gear train, a sequence valve, a filler plug, a sight gauge, and a hydraulic motor. The gear train rotates because of the hydraulic motor. The gear train turns the rotary-wing head by running the rotor brake disc. The hydraulic disc motor operates only after the gear train engages the teeth of the rotor brake disc. Pressure is cut off to the blade rotation control valve and the motor by the sequence valve. This action occurs when the gear train has been operated to disengage the rotor brake disc.

ROTOR COUPLING.—The rotor coupling is found at the bottom of the rotary-wing shaft. It serves to transfer hydraulic fluid to the rotary-wing head for blade folding. Figure 17-14 shows a cross-sectional view of the coupling. The coupling consists of a spindle that revolves with the rotary-wing shaft. A stationary housing connects to hydraulic lines of blade folding components. Hydraulic fluid is sent through the rotor coupling, and then through the lock valve. Pressure is then sent to the manifold, to the

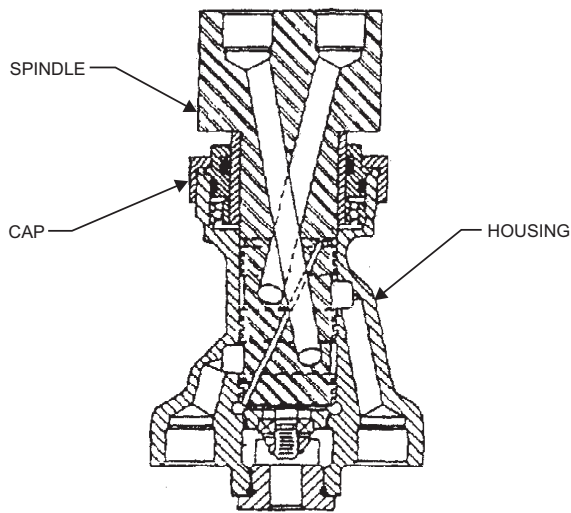

Figure 17-14.—Rotor coupling.

damper-positioner shuttle valve, and to the damper-positioner sequence valves.

CONTROL LOCK CYLINDER.—The control lock cylinder is on the No. 2 blade horn assembly rotary-wing head. During the fold cycle, the control lock cylinder locks the flight controls. This occurs only after the blade has been positioned. During the spread cycle, it unlocks the controls. A microswitch within the housing of the cylinder causes the CONT LOCKPIN ADV advisory light in the cockpit to light. In event of hydraulic malfunction, the control lockpin may be operated manually. This is done by turning a sector gear bolt on the aft end of the cylinder. The sector bolt rotates gear teeth on the end of the actuating piston shaft.

BLADE FOLD ACCUMULATOR.—A blade fold accumulator is found inside of the rotary-wing sleeve of the No. 1 blade. It has a preload of 1,500-psi nitrogen pressure to maintain hydraulic pressure in the rotary-wing head. The pressure is necessary to keep the damper-positioners extended and the blade locked in the folded position. It serves to compensate for expansion and contraction of the hydraulic fluid because of temperature changes. It also dampens out pressure surges during fold and spread cycles.

AUTOMATIC BLADE FOLDING SYSTEM MAINTENANCE

Maintenance of the blade fold system consists of periodic inspection, lubrication, operational testing, and troubleshooting. Allowable maintenance at the organizational level includes alignment, adjustment, and the removal and installation of components. Parts replacement and cure date kits are available for

intermediate-level repair of defective parts. Before removal of any component, secure the blades to prevent damage. Whenever any part of the system is repaired or replaced, the electrical portion of the system should be tested, as required by the MIM. Operationally check the entire hydraulic portion of the system to ensure proper sequence of operation. The hydraulic testing procedures discussed in the following paragraphs are used as an example. Always consult your MIM for correct procedures.

Charge the air accumulator with 1,500 psi of nitrogen, with the blades in the spread position. Connect a source of external hydraulic power to the utility, primary, and auxiliary hydraulic systems. Set pressure to 3,000 psi at approximately 3 gallons per minutes for the utility system. Set pressure to 1,500 psi for the primary and auxiliary servo hydraulic systems. Position the ACCESSORY DRIVE switch to ACCESS DR. The accessory drive light will light. At the start of the testing, make sure that PRI SERVO PRESS, AUX SERVO PRESS, ACCESSORY DRIVE, ROTOR BRAKE ON, and CHECK BLADE FOLD lights will light. The ACCESSORY DRIVE, FLIGHT POS, BLADE SPREAD, EXT PWR ON, PRI SERVO PRESS, and AUX SERVO PRESS lights should be lit. Visually check to see that the lockpins are disengaged. Manually rotate the rotary head until the leading edge of the No. 1 blade is in the aft position. Engage the rotor brake. The rotor brake pressure gauge should read a minimum of 320 psi. Check that the rotor brake light comes on. Place the collective pitch stick in the full low position and the cyclic pitch stick in neutral. Visually examine the control lock cylinder to make sure that the pin is aligned with its hole. When the controls are positioned, trip the FOLD manual override on the blade fold control valve and hold it in this position. No action should result. Release the override. Position the SAFETY VALVE switch to OPEN. Check that the SAFETY VALVE OPEN light comes on. Trip the manual override again. The dampers will position, the control lockpin will engage,

WARNING

Ensure that the path of the blade is clear before tripping the manual override. Failure to do so could result in personal injury or damage to the aircraft. The cyclic control stick may have to be moved slightly around neutral to engage the control lockpin.

and the blade lockpin will disengage. The blade will fold, and the PRI SERVO PRESS light will go off.

Check the lights on the blade fold panel. CONT LOCKPIN ADV, BLADE FOLDED, CHECK BLADE FOLD, SAFETY VALVE OPEN, AND ACCESS DR ON lights should be lighted. The BLADE SPREAD light should be off. Trip the manual override button to SPREAD. The blade will spread and the lockpin will engage. The control lockpin will disengage. The BLADE SPREAD and CHECK BLADE FOLD lights will come on. Position the SAFETY VALVE switch to CLOSED. Check to see that the SAFETY VALVE OPEN and CHECK BLADE FOLD lights go off within 1 1/2 seconds and that the FLIGHT POS light comes on. Release the rotor brake to make sure that the ROTOR BRAKE ON light goes off. Manually reposition the No. 1 blade to the right of the helicopter centerline. Position the safety valve switch to OPEN and the master switch to ON. Make sure that SAFETY VALVE OPEN and FOLD PWR ON lights come on. Check to see that the ACCESSORY DR ON light is on. The rotor brake should disengage automatically. Hydraulic pressure should disengage the blade positioner drive unit from the rotor brake disc.

The final movements of blade positioning may result in a position hunting motion or chatter. If this chatter is sustained for more than 3 seconds, investigate the cause. Position the blade fold switch to FOLD. The No. 1 BLADE POSITION light will come on. Apply the rotor brake manually. Damper-positioners will position, the control lockpin will engage, and the CONT LOCKPIN ADV light will illuminate. The blade lockpin will retract, and the BLADE SPREAD light will go off. The BLADE FOLDED and CHECK BLADE FOLD lights will come on.

NOTE: Automatic fold cycle time is approximately 30 seconds for the rotary-wing

positioning. The normal time for damper positioning is 5 seconds, and normal time for blade folding is 27 to 41 seconds.

Make sure that the accumulator gauge on the No. 1 blade sleeve spindle maintains 3,000 psi. The damper-positioners should remain in full extended or autorotative position. The blades should remain folded. Position the blade fold switch to SPREAD, and check the reversing of operation. When the BLADE SPREAD light comes on, position the safety valve switch to CLOSED (SAFETY VALVE OPEN and FOLD PWR ON lights should then go out). Position MASTER and BLADE FOLD switches to OFF. CHECK BLADE FOLD light will go off, and FLIGHT POS light will come on. Visually check control lockpin for disengagement. Move the No. 1 blade to the left of the helicopter centerline. Repeat the automatic folding sequence. Following the hydraulic testing, inspect all components for external leakage.

Q17-25. What test is required after a helicopter has been rigged?

Q17-26. Proper blade tracking prevents what condition?

Q17-27. What blade-tracking device can be used in flight or on the ground?

Q17-28. What assembly is comparable to a single disc wheel brake in its design and operation?

Q17-29. What component prevents hydraulic pressure from entering the blade fold system during flight?

Q17-30. What is the blade fold accumulator nitrogen preload pressure that maintains hydraulic pressure in the rotary-wing head?

Q17-31. Before you charge the blade fold accumulator with nitrogen, the blades should be in what position?

APPENDIX I

GLOSSARY

- ABRADE**—To scrape or rub off.
- ACCUMULATOR**—An apparatus that collects and stores energy.
- ACRYLIC**—Designation of an acrylic resin product.
- ACRYLIC RESIN**—Group of transparent, thermoplastic, polymeric resins used in making molded plastics, paints, textile fibers, etc.
- ACTUATOR**—A mechanism for moving or controlling something indirectly.
- ADDITIVES**—Substances added, in relatively small amounts, to improve another substances physical properties or performance.
- ADHESION**—An action that causes one substance to adhere to another.
- AFCS**—Automatic Flight Control System.
- AIMD**—Aircraft intermediate maintenance department.
- AIRFOIL**—A structure or body, such as an aircraft wing or propeller blade, designed to provide lift/thrust when in motion relative to the surrounding air.
- ALCLAD**—Trade name of an aluminum laminate originated by the Aluminum Company of America.
- ALIPHATIC**—Major group of organic compounds, structured in open chains, including paraffins, olefins, and acetylenes.
- ALLOY**—A mixture with metallic properties composed of two or more elements, of which at least one is a metal.
- AMBIENT**—Surrounding; adjacent to, next to. For example, ambient conditions are physical conditions of the immediate area, such as ambient temperature, ambient humidity, ambient pressure, etc.
- ANHYDROUS**—Without water.
- ANNEAL**—To heat and then cool.
- ANNULAR**—Relating to or forming a ring.
- ANNUNCIATOR**—Electrically controlled signal board or indicator.
- ANODIZE**—To subject a metal to electrolytic action, as the anode of a cell, in order to coat it with a protective film.
- ANTIOXIDANTS**—A substance that opposes oxidation or inhibits reactions promoted by oxygen or peroxides.
- APEX**—The uppermost point.
- ASW**—Antisubmarine warfare.
- ASYMMETRY**—Lack of symmetry.
- AUTOROTATION**—The turning of the rotor of a helicopter, with the resulting lift caused solely by the aerodynamic forces induced by the motion of the rotor along its flight path.
- AXIAL**—Situated around, in the direction of, on or along an axis.
- BALLISTIC**—Relating to ballistics or to a body in motion according to the laws of ballistics.
- CANNIBALIZATION**—To take salvageable parts from one machine for the use in repairing or building another machine.
- CARBONACEOUS**—Consisting of or containing carbon.
- CATALYSTS**—A substance that initiates a chemical reaction and enables it to proceed under different conditions than otherwise possible.
- CAVITATE**—To form cavities or bubbles.
- CFA**—Cognizant field activity.
- CHLORIDES**—A compound of chlorine with another element or group.
- CHROMATE**—A salt or ester of chromic acid.
- CIRCUMFERENTIAL**—Perimeter of a circle.
- CNO**—Chief of Naval Operations
- COGNIZANT**—Official observation of or authority over something.

- COMPENSATOR**—Any of various devices or circuits used to correct or offset some disturbing action, such as speed deviations in a moving system or excessive current in a circuit.
- CONCAVE**—Hollowed or rounded inward like the inside of a bowl.
- CONTAMINANTS**—Substances that contaminate other substances.
- CONVEX**—Curving outward like the surface of a sphere.
- COUNTERSINK**—To set the head of a screw at or below the surface.
- CRES**—Corrosion-resistant steel.
- CRYSTALLINE**—Composed of crystals.
- CYLINDRICAL**—Relating to or having the form or properties of a cylinder.
- DEAERATE**—To remove air or gas from.
- DECONTAMINATE**—To rid of contamination.
- DESICCANT**—A drying agent.
- DETERIORATION**—The act or process of becoming impaired in quality, functioning, or conditioning.
- DYNAMIC SEA**—Seal between two parts with relative motion.
- ELECTROHYDRAULIC**—A combination of electric and hydraulic mechanisms.
- ELONGATED**—Stretched out.
- EMULSION**—A suspension of small globules of one liquid in a second liquid with which the first will not mix, such as milk fats in milk.
- EPOXY**—A compound in which an oxygen atom is joined to each of two attached atoms, usually carbon. Designation of various thermosetting resins, containing epoxy groups, that are blended with other chemicals to form strong, hard, chemically resistant substances, such as adhesives, paints, etc.
- ERRATIC**—Deviating from the normal, conventional, or customary course.
- EUTECTIC**—Mixture or alloy with a melting point lower than that of any other combination of the same components.
- EXTRUDED**—To push or force out, expel. To force (metal, plastic, etc.) through a die or very small holes to give it a certain shape.
- FERROUS**—Substances containing iron.
- FIBER**—A single strand of material that is rolled or formed in one direction, and used as a principal constituent in composite material because of its high axial strength and modulus.
- FUSIBLE**—Liquified by heat, easily melted.
- GALLING**—Chafing.
- GPM**—Gallons per minute.
- HALOGEN**—Any of the five nonmetallic chemical elements fluorine, chlorine, bromine, astatine, and iodine.
- HELICAL**—Something spiral in shape.
- HONEYCOMB**—A strong, lightweight, cellular structural material.
- HP**—Horsepower.
- HYDRAULICALLY**—Operated by the resistance offered or by the pressure transmitted when a quantity of liquid, such as water or oil, is forced through a small orifice or tube.
- HYDROCARBON**—An organic compound containing only carbon and hydrogen and often occurring in petroleum, natural gas, coal and bitumens.
- HYDROCHLORIC ACID**—A strong, highly corrosive acid that is a water solution of the gas hydrogen chloride, and is widely used in the processing of ore and for cleaning metals.
- HYDROLYZE**—To decompose a compound by splitting it into other compounds by taking up water.
- IMBEDDED**—To make something an integral part of.
- IMPREGNATED**—To furnish one substance with some actuating or modifying substance that is infused or introduced. An example is the nonwoven, non-metallic, abrasive mats that are used for the removal of corrosion products and paint scuffing prior to painting. These abrasive mats are, in effect, nylon webbing, impregnated with aluminum oxide.
- INERT**—Lacking a usual or anticipated chemical or biological action.
- INHIBITOR**—An agent that slows or interferes with a chemical reaction.

INTEGRAL FUEL CELL—A structural configuration in which a component of the aircraft serves as a fuel container.

KEVLAR®—Tough, light, aramid synthetic fiber used in making bulletproof vests, boat hulls, airplane parts, etc.

KNURLED—A series of small ridges or beads placed along the edge of a metal object, such as a thumbscrew, as an aid in gripping.

LAMINA—A single ply of composite material, made up of a reinforcing element and matrix (laminae—plural of lamina).

LAMINATE—A combination of two or more single piles of laminae bonded together to form a structure.

LAMINATE ORIENTATION CODE—A code that sets the standard of identifying laminate orientations within the composite industry.

MATRIX—The essentially homogeneous material in which the fibers of a composite are embedded and supported.

MICROMETER CALIPER—A caliper having a spindle moved by a finely threaded screw for making precise measurements.

MICRON—A millionth of a meter or about 0.000039 inch.

MIM—Maintenance Instruction Manual.

ML—Milliliter.

MM—Millimeter.

MRC—Maintenance requirements card.

NADEP—Naval aviation depot.

NAMP—Naval Aviation Maintenance Program.

NAPI—Naval Aeronautical Publication Index.

NAVAIR—Naval Air Systems Command. Also known as NA and NAVAIRSYSCOM.

NAVOSH—Navy Occupational Safety and Health Program.

NDI—Nondestructive inspection.

NEOPRENE—A synthetic rubber.

NONFERROUS—Metals other than iron.

OPTIMUM—The greatest degree attained or attainable under implied or specified conditions.

OSCILLATION—A flow of electricity changing periodically from a maximum to a minimum. A single swing from one extreme limit to the other.

OXIDATION—The process by which oxygen unites with some other substance, causing rust or corrosion.

P/N—Part number.

PERIMETER—A line or strip protecting or bonding an area.

PMIC—Periodic maintenance inspection card.

PNEUMATIC—Moved or worked by air pressure.

POTENTIOMETER—An instrument for controlling, comparing, or measuring electrical potentials.

PPM—Parts per million.

PSI—Pounds per square inch.

RADIUS—A line segment extending from the center of a circle or sphere to the circumference or bounding surface.

RPM—Revolutions per minute.

SAE—Society of Automotive Engineers.

SATURATION—A state of maximum impregnation.

SERRATION—A formation resembling the toothed edge of a saw.

SILICA—A hard, glassy, mineral found in a variety of forms, as in quartz, sand, opals, etc.

SPHERICAL—Having the form of a sphere or of one of its segments.

SPLINE—A key that is fixed to one of two connected mechanical parts and fits into a keyway in the other.

TEFLON®—A tough, insoluble polymer, used in making nonsticking coatings and used on gaskets, bearing electrical insulators, etc.

THERMOPLASTIC—Capable of softening or fusing when heated and of hardening again when cooled.

TOXIC—Harmful, destructive, poisonous materials.

ULTRASONIC—Having a frequency above the human ear's audibility limit.

VISCOSITY—The internal resistance of a liquid that tends to prevent it from flowing.

WARPAGE—A distortion, such as a twist or bend, in metal or an object made of metal.

APPENDIX II

REFERENCES USED TO DEVELOP THE NONRESIDENT TRAINING COURSE

Although the following references were current when this Course was published, their continued currency cannot be assured. When consulting these references, keep in mind that they may have been revised to reflect new technology or revised methods, practices, or procedures. Therefore, you need to ensure that you are studying the latest references.

Chapter 1

Use and Care of Hand Tools and Measuring Tools, NAVEDTRA 14256, Naval Education and Training Professional Development and Technology Center, Pensacola, Florida, June 1992.

Blueprint Reading and Sketching, NAVEDTRA 14040, Naval Education and Training Professional Development and Technology Center, Pensacola, Florida, May 1994.

Fluid Power, NAVEDTRA 14015, Naval Education and Training Professional Development and Technology Center, Pensacola, Florida, July 1990.

Naval Aviation Maintenance Program, OPNAVINST 4790.2 (series), Office of the Chief of Naval Operations, Washington, D.C., 1 June 2001.

Aviation Hydraulics Manual, NAVAIR 01-1A-17, Commander, Naval Air Systems Command, Washington, D.C., 1 August 1996, RAC-8 15 August 1997.

General Manual for Structural Repair, NAVAIR 01-1A-1, Commander, Naval Air Systems Command, Washington, D.C., 1 May 2001.

Structural Hardware, NAVAIR 01-1A-8, Commander, Naval Air Systems Command, Washington, D.C., 1 October 1999.

Naval Occupational Safety and Health (NAVOSH) Program Manual For Forces Afloat, OPNAVINST 5100.19D, Commander, Naval Air Systems Command, Washington, D.C., 30 August 2001.

Naval Occupational Safety and Health (NAVOSH) Program Manual, OPNAVINST 5100.23E, Commander, Naval Air Systems Command, Washington, D.C., 15 January 1999.

Navy Support Equipment Common Basic Handling and Safety Manual, NAVAIR 00-80T-96, Commander, Naval Air Systems Command, Washington, D.C., 1 April 1996.

Technical Manual Index and Application Tables for Aircraft Jacks, NAVAIR 19-70-46, Commander, Naval Air Systems Command, Washington, D.C., 1 November 1989.

Technical Manual USN Aircraft Weight and Balance Control, NAVAIR 01-1B-50, Commander, Naval Air Systems Command, Washington, D.C., 1 October 1990.

Technical Manual Weight and Balance Data, NAVAIR 01-1B-40, Commander, Naval Air Systems Command, Washington, D.C., 1 October 1990.

Organizational, Intermediate, and Depot Maintenance Inspection and Proofload Testing of Lifting Slings and Restraining Devices for Aircraft and Related Components, NAVAIR 17-1-114, Commander, Naval Air Systems Command, Washington, D.C., 30 September 2000.

Technical Manual Procedural Instructions—Aircraft Securing and Handling, NAVAIR 17-1-537, Commander, Naval Air Systems Command, Washington, D.C., 1 October 1991, RAC-1, 1 July 1993.

Chapter 2

General Advanced Composite Repair Manual, Tech Order 2-2-690, Secretary of the Air Force, Washington, D.C., 1990.

Fabrication, Maintenance, and Repair of Transparent Plastics, NAVAIR 01-1A-12, Naval Air Systems Command, Washington, D.C., 3 June 1957, Change 10, 1 July 1982.

Airspace Metals—General Data and Usage Factors, NAVAIR 01-1A-9, Naval Air Systems Command, Washington, D.C., 26 February 1999, Change 1, 25 June 2001.

Aircraft Radomes and Antenna Covers, NAVAIR 01-1A-22, Naval Air Systems Command, Washington, D.C., 1 June 1988, Change 2, 15 October 1995.

General Manual for Structural Repair, NAVAIR 01-1A-1, Commander, Naval Air Systems Command, Washington, D.C., 1 May 2001.

Airframe and Landing Gear System, NAVAIR A1-H60BB-110-100, Navy Model SH-60B, Commander, Naval Air System Command, Washington, D.C., 1 December 1999.

Rotor Systems, NAVAIR A1-H60CA-150-100, Navy Model SH-60B, SH-60F, HH-60H, Coast Guard Model HH-60J, Commander, Naval Air System Command, Washington, D.C., 31 May 1992, Change 7, 6 February 1995.

Integrated Flight Controls, NAVAIR A1-F18AC-570-100, Navy Model F/A-18A/B/C/D 161353 and Up, Commander, Naval Air Systems Command, Washington, D.C., 15 June 1998, Change 2, 1 July 2001.

Chapter 3

Structural Hardware, NAVAIR 01-1A-8, Commander, Naval Air Systems Command, Washington D.C., 1 October 1999.

Chapter 4

Use and Care of Hand Tools and Measuring Tools, NAVEDTRA 14256, Naval Education and Training Professional Development and Technology Center, Pensacola, Florida, June 1992.

Blueprint Reading and Sketching, NAVEDTRA 14040, Naval Education and Training Professional Development and Technology Center, Pensacola, Florida, July 1994.

Aerospace Metals—General Data and Usage Factors, NAVAIR 01-1A-9, Naval Air Systems Command, Washington, D.C., 26 February 1999, Change 1, 25 June 2001.

General Manual for Structural Repair, NAVAIR 01-1A-1, Commander, Naval Air Systems Command, Washington, D.C., 1 May 2001.

General Manual for Aircraft Battle Damage Repair, NAVAIR 01-1A-39, Commander, Naval Air Systems Command, Washington, D.C., 15 July 1985, Change 2, 15 February 1993.

Structural Hardware, NAVAIR 01-1A-8, Commander, Naval Air Systems Command, Washington, D.C., 1 October 1999.

Organizational, Intermediate, and Depot, Aircraft Fuel Cells, and Tanks, NAVAIR 01-1A-35, Commander, Naval Air Systems Command, Washington, D.C., 15 January 2001.

Chapter 5

Adhesive Bonded Aerospace Structure Repair, MIL-HDBK-337, Department of Defense, Washington D.C., 1982.

Aircraft Radomes and Antenna Covers, NAVAIR 01-1A-22, Naval Air Systems Command, Washington, D.C., 1 June 1988, Change 2, 15 October 1995.

Composite Repair, A1-F18AA-SRM-400, Commander, Naval Air Systems Command, Washington, D.C., 1982.

Fabrication, Maintenance and Repair of Transparent Plastics, NAVAIR 01-1A-12, Naval Air Systems Command, Washington, D.C., 3 June 1957, Change 10, 1 July 1982.

Finishes, Organic, Weapons Systems, MIL-F-18264D(AS), Department of Defense, Washington D.C., 1975.

General Advanced Composite Repair Manual, Tech Order 1-1-690, Secretary of the Air Force, Washington, D.C., 1 August 1990.

General Use of Cements, Sealants, and Coatings, NAVAIR 01-1A-507, Naval Air Systems Command, Washington, D.C., 9 June 1967, Change 10, 3 February 1987.

Marking and Exterior Finish Colors for Airplanes, MIL-M-25047C(ASG), Naval Air Systems Command, Washington, D.C., 1968.

Paint Schemes and Exterior Markings for U.S. Navy and Marine Corps Aircraft, MIL-STD-2161(AS), Department of Defense, Washington, D.C., 1985.

Plastics for Aerospace Vehicles, Parts I and II, MIL-HDBK-17A, Department of Defense, Washington, D.C., June 1977.

Structural Sandwich Composites, MIL-HDBK-23A, Department of Defense, Washington, D.C., June 1974.

Typical Repair, A1-F18AA-SRM-250, Commander, Naval Air Systems Command, Washington, D.C., 1 August 1992.

Chapter 6

Nondestructive Inspection Methods, NAVAIR 01-1A-16, Naval Air Systems Command, Washington, D.C., 1 October 1997, Change 3, 1 March 2000.

Aerospace Metals—General Data and Usage Factors, NAVAIR 01-1A-9, Naval Air Systems Command, Washington, D.C., 26 February 1999, Change 1, 25 June 2001.

Aeronautical and Support Equipment Welding, NAVAIR 01-1A-34, Commander, Naval Air Systems Command, Washington, D.C., 1 April 1998.

Chapter 7

Aircraft Wheels, NAVAIR 04-10-1, Commander, Naval Air Systems Command, Washington, D.C., 2 August 1997.

Aircraft Tires and Tubes, NAVAIR 04-10-506, Commander, Naval Air Systems Command, Washington, D.C., 1 December 1989, Change 7, 1 July 1996.

Structural Hardware, NAVAIR 01-1A-8, Commander, Naval Air Systems Command, Washington, D.C., 1 October 1999.

Aircraft Weapons Systems Cleaning and Corrosion Control, NAVAIR 01-1A-509, Commander, Naval Air Systems Command, Washington, D.C., 1 May 2001.

Tire Inflator Assembly Kit, NAVAIR 17-1-123, Commander, Naval Air Systems Command, Washington, D.C., 1 March 1998.

Chapter 8

Aviation Hydraulics Manual, NAVAIR 01-1A-17, Commander, Naval Air Systems Command, Washington, D.C., 1 August 1996, RAC 8, 15 August 1997.

Naval Aviation Maintenance Program, OPNAVINST 4790.2, Office of the Chief of Naval Operations, Washington, D.C., 1 June 2001.

Navy Support Equipment Common Basic Handling and Safety Manual, NAVAIR 00-80T-96, Commander, Naval Air Systems Command, Washington, D.C., 1 April 1996.

Fluid Power, NAVEDTRA 14015, Naval Education and Training Program Management Support Activity, Pensacola, Florida, July 1990.

Structural Hardware, NAVAIR 01-1A-8, Commander, Naval Air Systems Command, Washington D.C., 1 October 1999.

Aviation Hose and Tube Manual, NAVAIR 01-1A-20, Commander, Naval Air Systems Command, Washington D.C., 1 July 1983, Change 4, 1 July 1997.

Chapter 9

Aviation Hydraulics Manual, NAVAIR 01-1A-17, Commander, Naval Air Systems Command, Washington, D.C., 1 August 1996, RAC 8, 15 August 1997.

Naval Aviation Maintenance Program, OPNAVINST 4790.2 (series), Office of the Chief of Naval Operations, Washington, D.C., 1 June 2001.

Navy Support Equipment Common Basic Handling and Safety Manual, NAVAIR 00-80T-96, Commander, Naval Air Systems Command, Washington, D.C., 1 April 1996.

Fluid Power, NAVEDTRA 14105, Naval Education and Training Professional Development and Technology Center, Pensacola, Florida, July 1990.

Chapter 10

Fluid Power, NAVEDTRA 14105, Naval Education and Training Professional Development and Technology Center, Pensacola, Florida, July 1990.

Naval Aviation Maintenance Program, OPNAVINST 4790.2 (series), Office of the Chief of Naval Operations, Washington, D.C., 1 June 2001.

Aviation Hose and Tube Manual, NAVAIR 01-1A-20, Naval Air Systems Command, Washington, D.C., 1 July 1983, Change 4, 1 July 1997.

Aviation Hydraulics Manual, NAVAIR 01-1A-17, Commander, Naval Air Systems Command, Washington, D.C., 1 August 1996, RAC-8 15 August 1997.

Chapter 11

Aviation Hydraulics Manual, NAVAIR 01-1A-17, Commander, Naval Air Systems Command, Washington, D.C., 1 August 1996, RAC-8 15 August 1997.

Fluid Power, NAVEDTRA 14015, Naval Education and Training Professional Development and Technology Center, Pensacola, Florida, July 1990.

Chapter 12

Aviation Hydraulics Manual, NAVAIR 01-1A-17, Commander, Naval Air Systems Command, Washington, D.C., 1 August 1996, RAC-8 15 August 1997.

Fluid Power, NAVEDTRA 14015, Naval Education and Training Professional Development and Technology Center, Pensacola, Florida, July 1990.

Chapter 13

Aviation Hydraulics Manual, NAVAIR 01-1A-17, Commander, Naval Air Systems Command, Washington, D.C., 1 August 1996, RAC 8, 15 August 1997.

General Manual for Structural Repair, NAVAIR 01-1A-1, Commander, Naval Air Systems Command, Washington, D.C., 1 May 2001.

Organizational Maintenance Testing and Troubleshooting Landing Gear and Related Systems, Navy Model F/A-18A/B/C/D Aircraft A1-F18AC-130-200, Commander, Naval Air Systems Command, Washington, D.C., 1 March 1997, Change 9, 1 October 2001.

Airframe and Landing Gear Systems, NAVAIR A1-H60BB-110-100, Navy Model SH-60B, Commander, Naval Air Systems Command, Washington, D.C., 1 December 1999.

Chapter 14

Aviation Hydraulics Manual, NAVAIR 01-1A-17, Commander, Naval Air Systems Command, Washington, D.C., 1 August 1996, RAC 8, 15 August 1997.

Organizational Maintenance Testing and Troubleshooting Landing Gear and Related Systems, Navy Model F/A-18A/B/C/D Aircraft A1-F18AC-130-200, Commander, Naval Air Systems Command, Washington, D.C., 1 March 1997, Change 9, 1 October 2001.

Technical Manual Index and Application Tables for Aircraft Jacks, NAVAIR 19-70-46, Commander, Naval Air Systems Command, Washington, D.C., 1 November 1989.

Technical Manual of Overhaul Instructions Main Wheel Brake Assembly, NAVAIR 03-25GAC-5, Commander, Naval Air Systems Command, Washington, D.C., 1 April 1966, RAC 1, 20 July 1973.

Technical Manual of Overhaul with Illustrated Parts Breakdown Hydraulic Brake, NAVAIR 03-25GAC-7, Commander, Naval Air Systems Command, Washington, D.C., 19 January 1970.

Chapter 15

Aviation Hydraulics Manual, NAVAIR 01-1A-17, Commander, Naval Air Systems Command, Washington, D.C., 1 August 1996, RAC 8, 15 August 1997.

Landing Gear and Arresting Gear Systems, Navy Model EA-6B Aircraft, NAVAIR 01-85ADC-2-3, Commander, Naval Air Systems Command, Washington, D.C., 1 August 1983, Change 14, 1 August 2001.

Landing Gear and Arresting Gear Systems, Navy Model EA-6A Aircraft, NAVAIR 01-85ADB-4-23, Commander, Naval Air Systems Command, Washington, D.C., 30 June 1983, Change 3, 15 November 1989.

Naval Aviation Maintenance Program, OPNAVINST 4790.2 (series), Office of the Chief of Naval Operations, Washington, D.C., 1 June 2001.

Organizational Maintenance Principles of Operational Landing Systems, Navy Model S-3A Aircraft, NAVAIR 01-S3AAA-2-2.3, Commander, Naval Air Systems Command, Washington, D.C., Change 9, 1 June 1992.

Organizational Maintenance Testing and Troubleshooting Landing Gear and Related Systems, Navy Model F/A-18A/B/C/D Aircraft A1-F18AC-130-200, Commander, Naval Air Systems Command, Washington, D.C., 1 March 1997, Change 9, 1 October 2001.

Testing and Troubleshooting Wing and Fin Fold Systems, Navy Model S-3A Aircraft, NAVAIR 01-S3AAA-2-2.10, Commander, Naval Air Systems Command, Washington, D.C., 15 March 1976, Change 8, 15 April 1989.

Chapter 16

General Manual for Structural Repair, NAVAIR 01-1A-1, Commander, Naval Air Systems Command, Washington, D.C., 1 May 2001.

Chapter 17

Helicopter History and Aerodynamics Manual, NAVAIR 00-80T-88, Commander, Naval Air Systems Command, Washington, D.C., 4 January 1961.

NATOPS Flight manual, Navy Model SH-60B Aircraft, A1-H60BB-NFM00A, Commander, Naval Air Systems Command, Washington, D.C., 15 March 1987, Change 1, February 1990.

Naval Aviation Maintenance Program, OPNAVINST 4790.2 (series), Office of the Chief of Naval Operations, Washington, D.C., 1 June 2001.

Principles of Operation Rotor Systems, Navy Model SH-60B Aircraft, A1-H60BB-150-100, Commander, Naval Air Systems Command, Washington, D.C., 312 March 1987, Change 2, 15 March 1988, RAC 1, 1 July 1988.

APPENDIX III

ANSWERS TO REVIEW QUESTIONS

CHAPTERS 1 THROUGH 17

Chapter 1

- A1-1. Instant inventory concept.*
- A1-2. Material Control officer.*
- A1-3. Quality Assurance.*
- A1-4. Fleet Material Support Office.*
- A1-5. Work center supervisor.*
- A1-6. Maintenance Officer (MO).*
- A1-7. OPNAVINST 5100.19 and OPNAVINST 5100.23.*
- A1-8. Material Safety Data Sheet.*
- A1-9. Work center supervisor.*
- A1-10. Warning.*
- A1-11. Caution.*
- A1-12. Block.*
- A1-13. Schematic.*
- A1-14. Installation.*
- A1-15. Troubleshooting.*
- A1-16. Visual inspection, operational check, classify the trouble, isolate the trouble, locate the trouble, correct the trouble, and conduct final operational check.*
- A1-17. Proper servicing levels.*
- A1-18. Hydraulic, pneumatic, mechanical, or electrical.*
- A1-19. Five (5).*
- A1-20. Hydraulic selector valves and electrical switches.*
- A1-21. Aircraft discrepancy records.*
- A1-22. Multimeter.*
- A1-23. Lubricants.*
- A1-24. Grease gun, squirt can, hand, and brush.*
- A1-25. Flush fittings.*
- A1-26. Maintenance Requirements Cards (MRC).*
- A1-27. Material Safety Data Sheet (MSDS).*
- A1-28. Flight.*

- A1-29. NAVAIR 01-1B-50.*
- A1-30. Mobile Electronic Weighing System (MEWS).*
- A1-31. Every six (6) months.*
- A1-32. Twenty (20) minutes.*
- A1-33. Weigh (or reweigh) and balance the aircraft.*
- A1-34. Wire rope, fabric or webbing, structural steel or aluminum, and chain.*
- A1-35. Wire rope.*
- A1-36. Structural steel.*
- A1-37. NAVAIR 17-1-114.*
- A1-38. Before each use or monthly.*
- A1-39. Axle and tripod.*
- A1-40. Standard authorized aircraft hydraulic fluid.*
- A1-41. Axle.*
- A1-42. AIMD Support Equipment Division.*
- A1-43. Safety locknuts.*
- A1-44. Aircraft MIMs.*
- A1-45. Three (3).*

Chapter 2

- A2-1. Nine.*
- A2-2. Longerons.*
- A2-3. Nacelle.*
- A2-4. Spar.*
- A2-5. To keep the aircraft in straight and level flight.*
- A2-6. Primary controls.*
- A2-7. Aileron.*
- A2-8. Power-operated or Power-boosted.*
- A2-9. Aileron.*
- A2-10. Elevator.*
- A2-11. Emergency wing sweep.*
- A2-12. Secondary flight controls.*
- A2-13. Reducing aircraft speed.*
- A2-14. Air-oil shock strut.*
- A2-15. The shimmy damper.*
- A2-16. Hydraulic power.*
- A2-17. The holdback assembly.*
- A2-18. Lift and control are independent of forward speed.*

- A2-19. *Monocoque.*
- A2-20. *Tension.*
- A2-21. *Compression.*
- A2-22. *Bending.*
- A2-23. *Torsion.*
- A2-24. *Aluminum alloy.*
- A2-25. *Magnesium.*
- A2-26. *225°F.*
- A2-27. *Reinforced plastic.*
- A2-28. *Hardness.*
- A2-29. *Elasticity.*
- A2-30. *1,110°F.*
- A2-31. *Corrosion.*
- A2-32. *Joining.*
- A2-33. *Hot-working, cold-working, and extruding.*
- A2-34. *Ferrous.*
- A2-35. *The Brinell and Rockwell tests.*
- A2-36. *Heat treatable and nonheat treatable.*
- A2-37. *Titanium alloys.*
- A2-38. *The diameter of the impression.*
- A2-39. *Measures the depth of the impression.*
- A2-40. *Rockwell tester.*
- A2-41. *Barcol tester.*
- A2-42. *Thermoplastic.*
- A2-43. *Thermosetting.*
- A2-44. *10°.*
- A2-45. *Graphite, Boron, and Kevlar®.*

Chapter 3

- A3-1. *Size, material, and head shape.*
- A3-2. *Countersunk.*
- A3-3. *1100-F.*
- A3-4. *5056.*
- A3-5. *Protruding head, and flush 100-degree countersunk head.*
- A3-6. *Blind.*
- A3-7. *Lock bolt.*

- A3-8. *4 parts.*
- A3-9. *Cadmium-plated alloy steel.*
- A3-10. *100-degree flush head, Hexagon protruding head, and 100-degree millable head.*
- A3-11. *Two.*
- A3-12. *Allen wrench.*
- A3-13. *It cannot be reused.*
- A3-14. *Castle nut.*
- A3-15. *Wing nut.*
- A3-16. *Klincher locknut.*
- A3-17. *Machine, structural, and self-tapping screws.*
- A3-18. *Structural screw.*
- A3-19. *82- and 100-degree only.*
- A3-20. *A self-tapping screw.*
- A3-21. *When bolts are installed at an angle to the surface.*
- A3-22. *3/4 inch.*
- A3-23. *Maintenance Instruction Manual (MIM).*
- A3-24. *Ball end.*
- A3-25. *By a groove or knurl around the end of the barrel.*
- A3-26. *7 threads.*
- A3-27. *Grommet.*
- A3-28. *Maintenance Instruction Manual (MIM).*
- A3-29. *Solderless crimped-type.*
- A3-30. *Static discharger.*
- A3-31. *Dial or beam-indicating type and the setting type.*
- A3-32. *NAVAIR 01-1A-8.*
- A3-33. *A cotter pin is used to secure bolts, nuts, screws, and pins.*
- A3-34. *Two.*
- A3-35. *Two.*

Chapter 4

- A4-1. *Mallet.*
- A4-2. *Rotary rivet cutter.*
- A4-3. *Bucking bar.*
- A4-4. *Tool steel.*
- A4-5. *Hole finder.*
- A4-6. *Copper.*

- A4-7. *Normally, shears are used to cut heavier gauge metal.*
- A4-8. *One-shot gun, fast-hitting gun, slow-hitting gun, corner gun, and squeeze riveter.*
- A4-9. *One-shot gun.*
- A4-10. *It can cause the drill to side slip and the hole to be elongated.*
- A4-11. *Vane air.*
- A4-12. *Snake drill.*
- A4-13. *Dimple.*
- A4-14. *Aluminum alloys are subject to cracking when formed.*
- A4-15. *Unishears.*
- A4-16. *Bar folder.*
- A4-17. *Box and pan brake.*
- A4-18. *Bluing fluid.*
- A4-19. *To indicate where the metal is to be cut or drilled.*
- A4-20. *Bend allowance.*
- A4-21. *Base measurement.*
- A4-22. *Radius.*
- A4-23. *Power and manual operated.*
- A4-24. *Rubber, plastic, or rawhide.*
- A4-25. *1/4 in.*
- A4-26. *Use a piece of scrap metal.*
- A4-27. *Two.*
- A4-28. *Slip-roll forming machine.*
- A4-29. *Beading rolls.*
- A4-30. *The thickness of the metal being riveted.*
- A4-31. *100°.*
- A4-32. *Huch rivet.*
- A4-33. *No. 31 drill bit.*
- A4-34. *Inspect for secondary damage.*
- A4-35. *Corrosion damage.*
- A4-36. *Foreign object damage.*
- A4-37. *Stress.*
- A4-38. *Elongation.*
- A4-39. *Hardness test.*
- A4-40. *Nondestructive inspection.*
- A4-41. *Negligible damage.*

- A4-42. *Damage requiring replacement.*
- A4-43. *Strength of the original part or structure.*
- A4-44. *Layout.*
- A4-45. *A template.*
- A4-46. *Aerodynamic filler.*
- A4-47. *Stop-drill both ends of the crack.*
- A4-48. *1/32 in.*
- A4-49. *The existing rivet pattern.*
- A4-50. *Spars.*
- A4-51. *Ribs.*
- A4-52. *Longeron.*
- A4-53. *Four.*
- A4-54. *Less total weight.*
- A4-55. *Brush, swab, or spray.*
- A4-56. *Bolts.*
- A4-57. *Seep.*
- A4-58. *Retorque all fasteners 6 inches on either side of the leak.*
- A4-59. *Every 30 seconds.*
- A4-60. *Nitrogen.*

Chapter 5

- A5-1. *Crazing.*
- A5-2. *Aliphatic naphtha.*
- A5-3. *Optical micrometer.*
- A5-4. *No. 240A.*
- A5-5. *Plain tallow.*
- A5-6. *Three (3) times greater.*
- A5-7. *Cellophane.*
- A5-8. *Scarfed method.*
- A5-9. *Rain erosion coating.*
- A5-10. *Puncture damage.*
- A5-11. *Flush patch.*
- A5-12. *A combination of high-strength stiff fibers embedded in a common matrix (binder) material.*
- A5-13. *Nondestructive inspection.*
- A5-14. *Kevlar[®] fibers.*
- A5-15. *Lamina.*

- A5-16. *Environmental damage.*
- A5-17. *Tap test.*
- A5-18. *A thinner area of a part.*
- A5-19. *Negligible damage.*
- A5-20. *Repairable damage.*
- A5-21. *The aircraft's structural repair manual (SRM).*
- A5-22. *Class VII.*
- A5-23. *Repair zones.*
- A5-24. *Leading edges of wings and tails, forward nacelles and inlet areas, and forward fuselages.*
- A5-25. *A hole saw.*
- A5-26. *Graphite.*
- A5-27. *Solvents.*
- A5-28. *Carbon and graphite fibers.*
- A5-29. *To protect exposed surfaces against corrosion and deterioration.*
- A5-30. *A decal or stencil located on the right side of the aircraft's aft fuselage.*
- A5-31. *The mildest means possible.*
- A5-32. *Wrinkled appearance.*
- A5-33. *Chemical conversion.*
- A5-34. *Eight (8) hours.*
- A5-35. *A preplacement and periodic medical evaluation.*
- A5-36. *Fifteen (15) feet.*
- A5-37. *Seven (7) days.*
- A5-38. *It is always one-sixth (1/6) of the height of the letter or numeral.*
- A5-39. *Optical principles.*
- A5-40. *Suction-feed type.*
- A5-41. *The fluid needle is not seating properly.*
- A5-42. *Between six (6) and ten (10) inches.*
- A5-43. *Excessive air pressure.*
- A5-44. *Three (3), pliable, drying, and curing.*
- A5-45. *An extrusion gun and spatula.*

Chapter 6

- A6-1. *Certified personnel only.*
- A6-2. *Eye exam.*
- A6-3. *3 years.*
- A6-4. *3 years.*

- A6-5. *Two times a month.*
- A6-6. *6 months.*
- A6-7. *The individual.*
- A6-8. *Quality Assurance (QA).*
- A6-9. *Naval Air Systems Command (NAVAIR).*
- A6-10. *Naval Air Systems Command (NAVAIR).*
- A6-11. *Aircraft Controlling Custodians (ACC).*
- A6-12. *Intermediate Maintenance Activity (IMA).*
- A6-13. *Quality Assurance (QA).*
- A6-14. *Organizational Maintenance Activity (OMA).*
- A6-15. *Iron.*
- A6-16. *Discontinuity.*
- A6-17. *Circular magnetization.*
- A6-18. *Inside surface.*
- A6-19. *Alternating current (ac).*
- A6-20. *Wet magnetic particle method.*
- A6-21. *High permeability and low retentivity.*
- A6-22. *Very fine discontinuities.*
- A6-23. *Black light.*
- A6-24. *Radiation (X-Ray).*
- A6-25. *They produce radiation.*
- A6-26. *Ultrasonic inspection.*
- A6-27. *Straight-beam.*
- A6-28. *Angle-beam.*
- A6-29. *Surface wave.*
- A6-30. *Eddy currents.*
- A6-31. *Surface coil.*
- A6-32. *Dye penetrant.*
- A6-33. *Naval Aviation Depot (NADEP).*
- A6-34. *3 years.*
- A6-35. *30 days.*
- A6-36. *To properly mix the gasses and direct the flame against the part to be welded.*
- A6-37. *5,700 to 6,300°F.*
- A6-38. *Odorless, colorless, and slightly heavier than air.*
- A6-39. *Breathing oxygen.*
- A6-40. *Working pressure.*

- A6-41. *A distinct odor.*
- A6-42. *29.4 psi.*
- A6-43. *Injector.*
- A6-44. *Red.*
- A6-45. *Right-handed threads.*
- A6-46. *Clear cover glass.*
- A6-47. *Nonferrous.*
- A6-48. *Carburizing flame.*
- A6-49. *Oxidizing flame.*
- A6-50. *Backfire.*
- A6-51. *Flashback is the burning of gases within the torch.*
- A6-52. *The joint to be welded.*
- A6-53. *Forehand method.*
- A6-54. *Fillet welds.*
- A6-55. *Groove welds.*
- A6-56. *Butt joint.*
- A6-57. *Tee joint.*
- A6-58. *Lap joint.*
- A6-59. *Edge joint.*
- A6-60. *Tungsten alloy.*
- A6-61. *At the electrode.*
- A6-62. *Gas cups.*
- A6-63. *Argon.*
- A6-64. *1/8 inch.*
- A6-65. *Gas Metal Arc (GMA).*
- A6-66. *Current level.*
- A6-67. *Helium.*
- A6-68. *To prevent sticking.*
- A6-69. *Counterclockwise.*
- A6-70. *Ensure it is firmly attached to the work piece.*
- A6-71. *Completely disconnect it.*
- A6-72. *Pure metal.*
- A6-73. *Distortion and cracking.*
- A6-74. *Uniformity.*
- A6-75. *Not in a stressed condition.*
- A6-76. *Soaking.*

- A6-77. *Preheating.*
- A6-78. *Quenching.*
- A6-79. *Oil.*
- A6-80. *Annealing.*
- A6-81. *Normalizing.*
- A6-82. *Hardening.*
- A6-83. *Tempering.*
- A6-84. *Case hardening.*
- A6-85. *Carburizing.*
- A6-86. *Nitriding.*
- A6-87. *Ferrite.*
- A6-88. *A soft condition.*
- A6-89. *Upper critical point.*
- A6-90. *Its color.*
- A6-91. *Alclad.*
- A6-92. *They are slightly overaged.*
- A6-93. *10 seconds or less.*
- A6-94. *Cold water.*
- A6-95. *Hot water.*
- A6-96. *Annealing.*
- A6-97. *Maximum softness.*

Chapter 7

- A7-1. *Aluminum or magnesium alloy.*
- A7-2. *Divided and demountable flange.*
- A7-3. *A lockring.*
- A7-4. *The wheel casting.*
- A7-5. *Brake drum or brake drive keys.*
- A7-6. *Corrosion and loss of bearing lubrication.*
- A7-7. *P-D-680, type II.*
- A7-8. *VV-L-800 oil.*
- A7-9. *One castellation (one-sixth turn).*
- A7-10. *Applicable MIM.*
- A7-11. *Intermediate maintenance activity (IMA).*
- A7-12. *NAVAIR 04-10-1.*
- A7-13. *One-sixteenth (1/16) inch.*
- A7-14. *MIL-G-81322 grease.*

- A7-15. *Pressure method.*
- A7-16. *0.020 inch.*
- A7-17. *The cord body.*
- A7-18. *Ribbed pattern.*
- A7-19. *Ply rating.*
- A7-20. *Laser beam optical holographic method.*
- A7-21. *The outside diameter.*
- A7-22. *VIDS/MAF.*
- A7-23. *The number of times the tire has been rebuilt.*
- A7-24. *100 psi.*
- A7-25. *A bright green dot.*
- A7-26. *Ultraviolet (UV) damage.*
- A7-27. *5 percent.*
- A7-28. *Red.*
- A7-29. *After each flight.*
- A7-30. *Lee-IX.*
- A7-31. *5 years.*
- A7-32. *By the word tubeless on the sidewall.*
- A7-33. *600 psi.*
- A7-34. *Every 6 months.*
- A7-35. *10 min.*
- A7-36. *Nonretreadable.*
- A7-37. *Soap and water.*
- A7-38. *Overinflation.*
- A7-39. *Type III.*
- A7-40. *Type III and type VII.*
- A7-41. *Talc.*
- A7-42. *Soapy water check.*
- A7-43. *Serviceable.*
- A7-44. *Repairable.*

Chapter 8

- A8-1. *Preservative hydraulic fluid.*
- A8-2. *-40°F to +275°F.*
- A8-3. *Aircraft logbook.*
- A8-4. *Navy Standard Class 5.*
- A8-5. *Applicable MIM's or MRC's.*

- A8-6. *MIL-H-5606, MIL-H-83282, MIL-H-46170, and MIL-G-81322.*
- A8-7. *Particulate contamination.*
- A8-8. *Microns.*
- A8-9. *Organic solid contamination.*
- A8-10. *Hydraulic pumps.*
- A8-11. *Air causes a spongy response during system operation.*
- A8-12. *Its mechanical features and its location in the system.*
- A8-13. *500 microns.*
- A8-14. *Patch test.*
- A8-15. *Immediately after flight and before shut down.*
- A8-16. *5 minutes.*
- A8-17. *Two.*
- A8-18. *47-mm filter.*
- A8-19. *15 cycles.*
- A8-20. *16 gallons.*
- A8-21. *NADEP (Naval Aviation Depot).*
- A8-22. *Recirculation.*
- A8-23. *Quick-disconnect coupling.*
- A8-24. *A spring in each half closes the valve.*
- A8-25. *A gasket.*
- A8-26. *Backup rings.*
- A8-27. *Moistureproof, pressure-sensitive tape.*
- A8-28. *Soft metal.*
- A8-29. *Teflon® backup rings do not have a shelf life.*
- A8-30. *To clean and lubricate.*

Chapter 9

- A9-1. *Leakage, system maintenance, and malfunction.*
- A9-2. *Portable, fluid dispensing, and stationary.*
- A9-3. *3-micron (absolute).*
- A9-4. *2 gallons.*
- A9-5. *1/4-gallon increments.*
- A9-6. *3-micron (absolute).*
- A9-7. *15-foot service hose.*
- A9-8. *Sight glass, gauge, and piston-style.*
- A9-9. *The applicable MIMs and MRCs.*

- A9-10. *They can be connected to an aircraft hydraulic system to provide power normally obtained from the aircraft hydraulic pumps.*
- A9-11. *Model 3-53 Detroit diesel engine.*
- A9-12. *Used for emergency diesel engine shutdown.*
- A9-13. *0 to 6000 psi.*
- A9-14. *The A/M27T-7 is powered by an electric motor.*
- A9-15. *NA 17-15BF-91.*
- A9-16. *Three-fourth full.*
- A9-17. *Allow the engine to warm up to its normal operating temperature.*
- A9-18. *Recirculation cleaning, deaeration, and fluid sample analysis.*
- A9-19. *Check the aircraft reservoir levels.*
- A9-20. *Pump compensator.*
- A9-21. *Used for shop-testing hydraulic system components.*
- A9-22. *Intermediate and depot.*
- A9-23. *Pneumatic components.*
- A9-24. *Electrical power, water, and compressed air.*
- A9-25. *Three test circuits.*
- A9-26. *Dynamic test circuit.*
- A9-27. *Safety interlock.*
- A9-28. *Upstream of the major fluid discharge port.*
- A9-29. *Clean, adequately secure polyethylene bag.*
- A9-30. *It allows entrapped air to escape from a closed hydraulic system.*
- A9-31. *Prefilling replacement components with new, filtered hydraulic fluid.*
- A9-32. *Self-recirculation cleaning.*
- A9-33. *MIL-PRF-680.*
- A9-34. *One quart.*
- A9-35. *Four.*
- A9-36. *25-micron (absolute) filter.*
- A9-37. *Flushing.*
- A9-38. *Purging.*

Chapter 10

- A10-1. *Synthetic rubber and Teflon®.*
- A10-2. *Braided stainless steel wire.*
- A10-3. *Indicator stripe and markings stenciled along the length of the hose.*
- A10-4. *Nipple, socket, swivel nut or flange, and the sleeve.*
- A10-5. *Blue.*

- A10-6. Identified by a band near one end of the assembly.*
- A10-7. Hose assembly identification tag or label.*
- A10-8. Firesleeve.*
- A10-9. Either a hydraulic or pneumatic pressure test.*
- A10-10. Check for proper torque.*
- A10-11. Eight years (32 quarters) from the cure date.*
- A10-12. Seven years (28 quarters).*
- A10-13. Outside diameter and wall thickness.*
- A10-14. Corrosion-resistant steel (CRES).*
- A10-15. Aluminum alloy tubing.*
- A10-16. Black.*
- A10-17. NA 01-1A-20.*
- A10-18. To produce a square end free from burrs.*
- A10-19. Remove all burrs.*
- A10-20. Obtain a smooth bend without flattening the tube.*
- A10-21. Flared and flareless.*
- A10-22. MIL-H-5606 hydraulic fluid.*
- A10-23. Dry-cleaning solvent MIL-PRF-680.*
- A10-24. Twenty percent.*
- A10-25. Two, permanent and temporary.*

Chapter 11

- A11-1. An actuating unit.*
- A11-2. Linear or reciprocating motion.*
- A11-3. Spring tension.*
- A11-4. A directional control valve.*
- A11-5. Double-acting type.*
- A11-6. Four.*
- A11-7. A ball-lock plunger.*
- A11-8. An inner cylinder.*
- A11-9. Hydraulic pressure and spring tension.*
- A11-10. Hydraulic pressure.*
- A11-11. To equalize the flow of fluid into the actuator piston chambers.*
- A11-12. External leakage.*
- A11-13. A hydraulic motor.*
- A11-14. Radar and wing flaps.*
- A11-15. A thermal relief valve.*

- A11-16. The cams on the camshaft.*
- A11-17. The neutral position.*
- A11-18. A damaged gasket under the sealing plug.*
- A11-19. The slide-type.*
- A11-20. Lands.*
- A11-21. Detents.*
- A11-22. To prevent corrosion.*
- A11-23. Electrically.*
- A11-24. The selector slide.*
- A11-25. 03 series.*
- A11-26. To prevent a leak from going undetected.*
- A11-27. To allow fluid to flow in one direction only.*
- A11-28. It can be manually opened to allow fluid to flow in both directions.*
- A11-29. Mechanically operated or pressure-operated.*
- A11-30. Balanced and unbalanced.*
- A11-31. Improper adjustment.*
- A11-32. The shuttle valve.*
- A11-33. Internal leakage.*
- A11-34. A restrictor.*
- A11-35. A two-way restrictor.*
- A11-36. It is a safety device.*
- A11-37. The control head.*

Chapter 12

- A12-1. Hydropneumatics.*
- A12-2. Two.*
- A12-3. An open-center system.*
- A12-4. The closed-center hydraulic systems selector or directional control valves are arranged in parallel and not in series.*
- A12-5. Continuous pressurization of the system is eliminated.*
- A12-6. Tandem construction.*
- A12-7. Two.*
- A12-8. Mechanically operated.*
- A12-9. The distance the piston rod protrudes from the reservoir end cap.*
- A12-10. Emergency systems.*
- A12-11. Variable displacement pumps.*
- A12-12. Gear-type pump.*

- A12-13. 13 gallons of fluid per minute at 3,800 rpm.*
- A12-14. To relieve excessive pressurized fluid caused from thermal expansion, pressure surges, and the failure of a hydraulic pump's compensator or other regulating devices.*
- A12-15. Turn the adjusting screw clockwise.*
- A12-16. To shut off the flow of hydraulic fluid to the engine in case of an engine fire.*
- A12-17. 400°F.*
- A12-18. Engine fuel.*
- A12-19. A manifold.*
- A12-20. A head assembly, a bowl, and a filter element.*
- A12-21. 5 micron (absolute).*
- A12-22. Manually.*
- A12-23. An automatic shutoff valve.*
- A12-24. Two.*
- A12-25. Pressurize the fluid chamber with compressed air to a predetermined charge.*
- A12-26. Direct reading and synchro (electric) type.*
- A12-27. A gauge and pressure transmitter snubber or snubbers.*
- A12-28. Electric-motor driven, ram-air turbine driven, or hand-operated.*
- A12-29. A spring-loaded turbine actuator.*
- A12-30. Blue.*

Chapter 13

- A13-1. A landing gear system is hydraulically operated and electrically controlled.*
- A13-2. Two main landing gears and one steerable nose landing gear.*
- A13-3. Either forward or rearward into the fuselage.*
- A13-4. When the weight of the aircraft is off the gear.*
- A13-5. Nonretractable gear.*
- A13-6. Retractable nose gear.*
- A13-7. The left main landing gear assembly.*
- A13-8. Cantilever type.*
- A13-9. The downlock cylinder.*
- A13-10. Mechanical linkage.*
- A13-11. Barber poles.*
- A13-12. The transition light in the landing gear handle.*
- A13-13. The same indications as during normal landing gear operation.*
- A13-14. The manually operated nitrogen bottle.*
- A13-15. Latches.*

- A13-16. *Hydraulic latch cylinder, latch hook, spring-loaded linkage, and a sector.*
- A13-17. *Up lock switch.*
- A13-18. *1/8 inch \pm 3/32 inch.*
- A13-19. *Length of the door linkage and adjustment of the doorstops.*
- A13-20. *Compressed air or nitrogen.*
- A13-21. *The lower chamber.*
- A13-22. *On the instruction plate attached to the strut.*
- A13-23. *When the aircraft hits the ground.*
- A13-24. *The compressed air or nitrogen.*
- A13-25. *A trunnion.*
- A13-26. *The applicable maintenance instruction manual (MIM).*
- A13-27. *Place the aircraft on jacks.*
- A13-28. *1800 psi at 4 gallons per minute (gpm).*
- A13-29. *Twenty pounds.*
- A13-30. *Ultrasonic leak detection translator.*
- A13-31. *Replacing the piston O-ring and delta rings.*
- A13-32. *Remove the tire/wheel and brake assembly to reduce the weight of the strut.*
- A13-33. *Type MS 28889.*
- A13-34. *Approximately two turns counterclockwise.*
- A13-35. *100 to 110 inch-pounds.*
- A13-36. *Fully extended.*
- A13-37. *During each preflight and postflight inspection.*
- A13-38. *Deflate the strut and tighten the packing gland nut.*
- A13-39. *Ensure that all pressure has been removed from the strut.*
- A13-40. *One hour.*

Chapter 14

- A14-1. *Independent type.*
- A14-2. *Gravity.*
- A14-3. *Top down method.*
- A14-4. *Used only to assist pedal movement.*
- A14-5. *Power brake control valve system.*
- A14-6. *Tuning fork.*
- A14-7. *It reduces the pressure to the brake and increases the volume of fluid flow.*
- A14-8. *Emergency brake systems.*
- A14-9. *Multiple or trimetallic disc brakes.*

- A14-10. *Pucks.*
- A14-11. *When the aircraft is being taxied.*
- A14-12. *Dual disc brakes.*
- A14-13. *Sixteen (16).*
- A14-14. *Automatic adjuster.*
- A14-15. *Segmented rotor.*
- A14-16. *Power brake system.*
- A14-17. *Sight gauge.*
- A14-18. *External hydraulic and electrical power.*
- A14-19. *Off.*
- A14-20. *Worn to a thickness of less than 1/16th (one-sixteenth) inch.*
- A14-21. *15 (fifteen) minutes.*
- A14-22. *Design.*
- A14-23. *Bleeder bomb.*
- A14-24. *45 (forty five) minutes.*
- A14-25. *2 (two) minutes.*
- A14-26. *Filtered, clean hydraulic fluid.*
- A14-27. *0 to 4,500 psi.*
- A14-28. *Hydraulic fluid.*
- A14-29. *An AM350-4 nut.*
- A14-30. *QA.*
- A14-31. *An adjusting spring.*
- A14-32. *Rivets.*
- A14-33. *Two (2) minutes.*
- A14-34. *Adjusting pins.*
- A14-35. *Fifty (50) percent.*
- A14-36. *AE (Aviation Electrician).*

Chapter 15

- A15-1. *Automatic nose gear shimmy dampening.*
- A15-2. *Two.*
- A15-3. *Automatically, by a switch actuated by the arresting hook.*
- A15-4. *A rotary, vane-type motor.*
- A15-5. *Feedback potentiometer, command potentiometer, and steering amplifier.*
- A15-6. *Balanced.*
- A15-7. *AM and AE personnel.*
- A15-8. *Three.*

- A15-9. Ten.*
- A15-10. Liquid spring.*
- A15-11. Vertical and horizontal damper cylinders.*
- A15-12. 500 pounds.*
- A15-13. Nose landing gear catapult launch system.*
- A15-14. Tension bar and catapult holdback bar.*
- A15-15. Two leaf springs.*
- A15-16. Check valve.*
- A15-17. The hydraulic system must be pressurize to 3000 psi, apply external electrical power, and engage the in-flight refueling system circuit breaker.*
- A15-18. Extension cycle 5 to 7 seconds and retraction cycle 9 to 11 seconds.*
- A15-19. Thermal relief valves.*
- A15-20. An indication of failure of all locks to properly enter the lock fittings.*
- A15-21. The hydraulic motor lockout relay.*
- A15-22. Variable ramp and bellmouth systems.*
- A15-23. Bellmouth ring.*
- A15-24. Three.*
- A15-25. A rack and piston arrangement.*

Chapter 16

- A16-1. Secondary flight control.*
- A16-2. Power-boost flight control system.*
- A16-3. Hydraulic pressure.*
- A16-4. Cables or pushrods.*
- A16-5. Hydraulic actuators.*
- A16-6. Independent hydraulic power source.*
- A16-7. The control valves.*
- A16-8. Nose down attitude.*
- A16-9. -6 degrees down to +1 degree up.*
- A16-10. 10.5 degrees trailing edge down to 24 degrees trailing edge up.*
- A16-11. Inboard flaperon raises 49 1/2 degrees.*
- A16-12. Outboard flaperon raises 53 degrees.*
- A16-13. 41 degrees.*
- A16-14. Aileron and Spoiler deflection system.*
- A16-15. Open with upward movement of the ailerons.*
- A16-16. Directional control system.*
- A16-17. Whenever a partial or complete hydraulic failure occurs.*

- A16-18. *When system pressure is decreased from 700 to 900 psi.*
- A16-19. *When the flight and combined systems fail.*
- A16-20. *It must be removed and replaced.*
- A16-21. *When the discrepancy has been determined and corrected.*
- A16-22. *“Could Not Duplicate” or “Replaced Suspected Component”.*
- A16-23. *Organizational-level maintenance.*
- A16-24. *Correct cable tension.*
- A16-25. *One.*
- A16-26. *It must be kept clean.*
- A16-27. *Six broken wires.*
- A16-28. *Three broken wires.*
- A16-29. *Three broken wires.*
- A16-30. *Used for frequent disconnecting.*
- A16-31. *Push-pull rods and bell cranks.*
- A16-32. *It must be checked for correct travel.*
- A16-33. *Change direction of motion when the airframe does not permit a straight run.*
- A16-34. *To protect against both overtension and overcompression.*
- A16-35. *Ensure neutral alignment of all connecting components.*
- A16-36. *30 pounds.*
- A16-37. *100 pounds.*
- A16-38. *Zero.*
- A16-39. *Lengthen the push-pull rod until the elevator trailing edge reads zero.*
- A16-40. *Seven strands and nineteen wires each.*
- A16-41. *Heavy-duty diagonal cutters, side cutters, or a pair of wire nippers.*
- A16-42. *A cable-cutting machine.*
- A16-43. *Minimum of 90 pounds of pressure.*
- A16-44. *NAVAIR 01-1A-8.*
- A16-45. *Connected by various kinds of hinges and slides.*
- A16-46. *Relieves pressure from thermal expansion.*
- A16-47. *60 +1, -2 degrees.*
- A16-48. *A 300-cubic-inch bottle charged to 3,000 psi.*
- A16-49. *Flap actuator.*
- A16-50. *27.5-degree leading edge down.*
- A16-51. *Increased lift for maneuvering and, at supersonic speeds, aerodynamic lift to reduce trim drag.*
- A16-52. *When the wings are overswept.*

- A16-53. *Speed brakes.*
- A16-54. *A five position, four throw, momentary ON contact switch with a center OFF position.*
- A16-55. *By repositioning the lateral control surfaces as necessary to achieve a balanced lateral flight condition.*
- A16-56. *By changing the incidence of the stabilizer.*
- A16-57. *A senior petty officer.*
- A16-58. *Check the identification tag to make sure it is the correct replacement unit.*
- A16-59. *Wing assembly.*
- A16-60. *A hand drill.*
- A16-61. *Drift pin.*
- A16-62. *It is directly related to the aerodynamic performance of the aircraft.*
- A16-63. *By adding weights to the inside of the leading edge of the control surface.*
- A16-64. *The aircraft must be level both laterally and longitudinally.*
- A16-65. *Jacks.*
- A16-66. *Four, two longitudinal and two lateral.*
- A16-67. *When the plumb bob pointer is at 0 degrees on the datum plate.*
- A16-68. *The wings must be folded and the aircraft leveled laterally.*

Chapter 17

- A17-1. *Rotor blades.*
- A17-2. *It is symmetrical.*
- A17-3. *The lift of a rotor is proportional to the square of the length of the rotor blades.*
- A17-4. *Parasite drag is reduced.*
- A17-5. *At sea level.*
- A17-6. *Torque.*
- A17-7. *By the wind when the helicopter is hovering.*
- A17-8. *Articulated rotor.*
- A17-9. *Coning.*
- A17-10. *Less.*
- A17-11. *Autorotation.*
- A17-12. *Power settling.*
- A17-13. *Single main rotor with vertical or near vertical tail rotor.*
- A17-14. *Tandem rotor system.*
- A17-15. *The vertical tail rotor.*
- A17-16. *Tandem rotors operate in opposite directions.*
- A17-17. *Cyclic pitch control system.*

- A17-18. Collective pitch control system.*
- A17-19. Directional heading.*
- A17-20. The negative force gradient spring.*
- A17-21. Four (4).*
- A17-22. Mixing unit.*
- A17-23. Pilot valve.*
- A17-24. The swashplate assembly.*
- A17-25. A flight test.*
- A17-26. Vibrations.*
- A17-27. The Strobes blade tracker.*
- A17-28. A rotor brake assembly.*
- A17-29. Safety valve.*
- A17-30. 1,500-psi nitrogen pressure.*
- A17-31. Spread position.*

Assignment Questions

Information: The text pages that you are to study are provided at the beginning of the assignment questions.

ASSIGNMENT 1

Textbook Assignment: "General Aircraft Maintenance," chapter 1, pages 1-1 through 1-35. "Aircraft Construction Materials," chapter 2, pages 2-1 through 2-15.

- 1-1. Ensuring that tools are procured and issued in a controlled manner consistent with the approved tool control plan is the responsibility of what officer?
1. The maintenance officer
 2. The material control officer
 3. The quality assurance officer
 4. The assistant maintenance officer
- 1-2. Which of the following reports should be used to report poor quality tools to FLEMATSUPPO?
1. EI
 2. HMR
 3. CAT I QDR
 4. CAT II QDR
- 1-3. Upon task assignment, you must record the tool container number on what copy of the VIDS/MAF?
1. Copy 1
 2. Copy 2
 3. Copy 3
 4. Copy 5
- 1-4. Who is responsible for training work center personnel in the use of Material Safety Data Sheets (MSDS)?
1. The safety officer
 2. The division officer
 3. The work center supervisor
 4. The maintenance control chief
- 1-5. What system/program is used to acquire, store, and disseminate data on hazardous materials procured for use?
1. Material Safety Data Sheets (MSDS)
 2. Navy Occupational Health and Safety (NAVOSH)
 3. Hazardous Material Information program (HMIP)
 4. Hazardous Material Information System (HMIS)
- 1-6. What section of a Material Safety Data Sheet (MSDS) identifies personal protective equipment required?
1. Section II
 2. Section V
 3. Section VII
 4. Section VIII
- 1-7. What safety term is used to indicate an operating procedure, practice, or condition, etc., that is essential to emphasize?
1. NOTE
 2. WARNING
 3. CAUTION
 4. ALERT
- IN ANSWERING QUESTIONS 1-8 AND 1-9, REFER TO FIGURE 1-3 IN THE TEXT.
- 1-8. Thin lines made up of long and short dashes alternately spaced and consistent in length are known by what name?
1. Hidden lines
 2. Center lines
 3. Dimension lines
 4. Extension lines
- 1-9. Thin lines terminated with arrowheads at each end are known by what name?
1. Hidden lines
 2. Leader lines
 3. Extension lines
 4. Dimension lines
- 1-10. What type of drawing is used to show details of parts, components, and other objects?
1. Pictorial
 2. Orthographic
 3. Block
 4. Exploded View

- 1-11. Efficient troubleshooting of an electrically controlled hydraulic system may require you to use a multimeter for which of the following reasons?
1. Check frequency
 2. Check voltage and continuity
 3. Relieve the AE of solving the problems
 4. To read the electrical portion of a schematic
- 1-12. After conducting a visual inspection and an operational check, what troubleshooting step should be next?
1. Locate the trouble
 2. Isolate the trouble
 3. Correct the trouble
 4. Classify the trouble
- 1-13. You are troubleshooting a malfunction and conducting the final operational check. What is the minimum number of times the affected system must be actuated?
1. 5
 2. 7
 3. 3
 4. 10
- 1-14. How many basic categories of malfunctions are there?
1. Five
 2. Two
 3. Four
 4. Three
- 1-15. What position should all electrical switches be in prior to applying electrical or hydraulic power?
1. Off only
 2. Safe only
 3. Normal only
 4. Off, safe, or normal
- 1-16. What total number of common methods are used to apply lubricants?
1. One
 2. Two
 3. Three
 4. Four
- 1-17. Flush lubrication fittings are used for which of the following reasons?
1. To prevent interference with moving parts
 2. To reach areas that are normally easy access
 3. To reach areas that are normally hard to access
 4. To lubricate areas that do not require much lubrication
- 1-18. To determine the type of lubricant and equipment to be used in a given area of an aircraft, you should refer to which of the following publications.
1. MIM only
 2. MRC only
 3. Both 1 and 2 above
 4. OPNAVINST 4790.2 (series)
- 1-19. How many forms of lubricants are there?
1. One
 2. Two
 3. Three
 4. Four
- 1-20. Why are lubricants necessary in aircraft components?
1. To cool parts
 2. To minimize friction
 3. To prevent corrosion
 4. To prevent wear
- 1-21. What document should you consult for safety precautions for a specific lubricant?
1. NAVAIR 01-1A-509
 2. Aircraft MRCs
 3. Aircraft MIMs
 4. Material Safety Data Sheet (MSDS)
- 1-22. What publication outlines the requirements, procedures, and responsibilities for weight and balance control?
1. NA 01-1B-50
 2. NA 01-1B-40
 3. OPNAVINST 4790.2
 4. NA 01-1A-50
- 1-23. Typically, a mobile electronic weighing system can be set up by two men in what minimum number of minutes?
1. 10 min
 2. 15 min
 3. 20 min
 4. 30 min

- 1-24. Heavy-duty portable scales must be calibrated at least how often?
1. Prior to use
 2. Once every 6 months
 3. Twice every 6 months
 4. Once every 12 months
- 1-25. Which of the following components is NOT normally a part of a weighing kit?
1. A plumb bob
 2. A chalk line
 3. A hydrometer
 4. A spirit level
- 1-26. After removing an aircraft from the scales, you must reweigh it if the scales do NOT return to zero within what number of minutes?
1. 5 min
 2. 10 min
 3. 15 min
 4. 20 min
- 1-27. Which of the following is NOT a type of aircraft lifting sling?
1. Wire rope
 2. Snatch cable
 3. Fabric webbing
 4. Structural steel
- 1-28. To find load testing and inspection information on aircraft lifting slings, you should consult what publication?
1. NAVAIR 01-1A-17
 2. NAVAIR 01-1A-20
 3. NAVAIR 17-1-114
 4. NAVAIR 17-15E-52
- 1-29. A group of wires twisted together is known by what name?
1. A wire rope
 2. A strand
 3. A cable
 4. A core
- 1-30. In reference to a cable, what does the term "bird cage" mean?
1. A kink that has been pulled through in order to straighten a cable
 2. A cable that is manufactured to look like a bird cage
 3. A cable that is improperly stored
 4. A neatly coiled cable
- 1-31. You should examine and lubricate all lifting slings at least how often?
1. Once a week
 2. Twice a week
 3. Once a month
 4. Twice a month
- 1-32. Hoisting restrictions for a specific type of aircraft can be found in which of the following publications?
1. NAVAIR 01-1A-8
 2. NAVAIR 01-1A017
 3. NAVAIR 15-02-500B
 4. Applicable MIM
- 1-33. What are the two types of aircraft jacks used by the Navy?
1. T-bar and camel
 2. Hand carried and T-bar
 3. Horseshoe and camel
 4. Axle and airframe (tripod)
- 1-34. Aircraft jacks are serviced with what type of fluid?
1. General-purpose oil
 2. Synthetic oil
 3. Aircraft hydraulic fluid
 4. Support equipment hydraulic fluid
- 1-35. What is another name for the T-bar axle jack?
1. Alligator jack
 2. Crocodile jack
 3. Toothpick jack
 4. Hard tail jack
- 1-36. A tripod jack consists of what total number of basic assemblies?
1. 3
 2. 4
 3. 6
 4. 8
- 1-37. A leg extension kit for a variable height tripod jack will increase its effective height by what total amount of inches?
1. 6 inches
 2. 12 inches
 3. 18 inches
 4. 24 inches

- 1-38. You are using three tripod jacks to jack an aircraft aboard a ship. What is the minimum number of tie-down chains that will be attached to the jacks?
1. 3
 2. 9
 3. 12
 4. 18
- 1-39. During jacking operation, the tie-down chain preload is too high when which of the following conditions exists?
1. The jack safety valve bypasses fluid
 2. The first stage locknut does not turn
 3. The tensioning grip cannot be rotated by hand
 4. The jack baseplate is seated flush with the deck
- 1-40. Special inspections for tripod jacks are required at what intervals?
1. Every 13 weeks
 2. Every 10 weeks
 3. Every 8 weeks
 4. Every 7 weeks
- 1-41. The shear load on a reinforced shell type fuselage is primarily carried by what structural component(s)?
1. The keel
 2. The skin
 3. The formers
 4. The stringers
- 1-42. In a semimonocoque fuselage design, longerons are supplemented by what other longitudinal members?
1. Bulkheads
 2. Stringers
 3. Station webs
 4. Vertical rings
- 1-43. What is the primary unit(s) that houses an aircraft engine?
1. Bulkhead
 2. Mount beam
 3. Nacelle
 4. Stringers, formers, and frames
- 1-44. What are the internal chordwise structural members of a wing assembly?
1. Rings
 2. Spars
 3. Stringers
 4. Rib
- 1-45. The skin of a wing assembly is fastened to which of the following structural components?
1. Ribs only
 2. Spars only
 3. Formers only
 4. Ribs, spars, and formers
- 1-46. The load imposed on the wings during flight acts primarily on what structural member(s)?
1. Beams
 2. Spars
 3. Skin
 4. Ribs
- 1-47. Which of the following is a primary flight control?
1. Rudder
 2. Spoiler
 3. Trim tab
 4. Wing flap
- 1-48. To roll an aircraft clockwise, you must cause which of the following changes in flight control positions?
1. Raise the left aileron and lower the right one
 2. Lower the left aileron and raise the right one
 3. Raise the elevators and move the rudder(s) to the left
 4. Lower the elevators and move the rudder(s) to the right
- 1-49. When the control stick of an aircraft equipped with a flaperon system is moved to the left, the left and right flaperons will be in which of the following positions?
1. Left down, right up
 2. Left up, right flush
 3. Left down, right flush
 4. Left flush, right down

- 1-50. Longitudinal control systems control movement of the aircraft about which of the following axes?
1. Lateral only
 2. Vertical only
 3. Longitudinal only
 4. Lateral, vertical, and longitudinal
- 1-51. Which of the following types of flaps operate on tracks and rollers?
1. Plain
 2. Split
 3. Fowler
 4. Leading edge
- 1-52. What is the primary purpose of a spoiler?
1. Increase lift
 2. Decrease lift
 3. Reduce airspeed
 4. Increase airspeed
- 1-53. A boundary layer control is used with which of the following secondary flight controls?
1. Slats
 2. Trim tabs
 3. Speed brakes
 4. Aileron droop
- 1-54. What part of an air-oil shock strut controls the rate of flow of the fluid between the piston and the cylinder?
1. The torque arm
 2. The metering pin
 3. The orifice plate
 4. The snubber orifice
- 1-55. During strut compression, fluid passes through an orifice into what camber of an air-oil type shock strut?
1. Aft
 2. Upper
 3. Lower
 4. Forward

ASSIGNMENT 2

Textbook Assignment: "Aircraft Construction and Materials," chapter 2, pages 2-16 through 2-43. "Aircraft Hardware," chapter 3, pages 3-1 through 3-12.

- 2-1. The shimmy damper on a nose landing gear assembly prevents the nosewheel from shimmying during takeoff and landing by what means?
1. By actuating a low-rate gear train
 2. By forcing a rotary bar to move against a friction plate
 3. By accentuating sudden torque loads applied to the nose wheel
 4. By metering hydraulic fluid through a small orifice between two cylinders or chambers
- 2-2. What component is used to hold the arresting hook in the down position to prevent it from bouncing when it strikes the carrier deck?
1. A snubber
 2. A drag ling
 3. A cable assembly
 4. A liquid centering spring
- 2-3. When comparing catapult hookup methods on a carrier, the nose gear launch method is superior to the holdback pendant method for all EXCEPT which of the following?
1. It saves time
 2. It cost less to operate
 3. It requires fewer personnel
 4. It is the safest method
- 2-4. Which of the following helicopter components provide(s) lift?
1. The engines
 2. The fuselage
 3. The tail rotor
 4. The rotor blades
- 2-5. What main landing gear component of a helicopter includes the weight-on-wheels sensing switch?
1. Left main landing gear
 2. Right main landing gear
 3. Tail gear
 4. Sponson
- 2-6. The tail landing gear of a helicopter is capable of swiveling how many degrees?
1. 45°
 2. 90°
 3. 180°
 4. 360°
- 2-7. What type of spar is used in the construction of a rotor blade?
1. Aluminum spar
 2. Magnesium spar
 3. Titanium spar
 4. Nickel spar
- 2-8. How many rotor blades are attached to the main rotor head of an H-60 helicopter?
1. Two
 2. Three
 3. Four
 4. Five
- 2-9. Which of the following components is NOT a part of the tail pylon of a helicopter?
1. The intermediate gearbox
 2. The tail gearbox
 3. The horizontal stabilator
 4. The swash plate
- 2-10. What type of stress is defined as "stress exerted when two pieces of fastened material tend to separate"?
1. Tension
 2. Compression
 3. Shear
 4. Bending
- 2-11. What type of stress is produced in an engine crankshaft while the engine is running?
1. Torsion
 2. Bending
 3. Compression
 4. Tension

- 2-12. What structural metal is lightweight, strong, and corrosion resistant?
1. Magnesium
 2. Titanium
 3. Nickel
 4. Aluminum
- 2-13. What is the largest portion of metal present in an alloy?
1. Main metal
 2. Base metal
 3. Foundation metal
 4. Major component metal
- 2-14. What high tensile metal is used to manufacture tubes, rods, and wires?
1. Aluminum
 2. Titanium
 3. Magnesium
 4. Alloy steel
- 2-15. What does the core material of reinforced plastic consist of?
1. Honeycomb structure
 2. Fiber cloth
 3. Bonding material
 4. Liquid resin
- 2-16. The strength of all metals is closely related to what other characteristic?
1. Hardness
 2. Denseness
 3. Brittleness
 4. Conductivity
- 2-17. What property of a metal allows for little bending and deformation without shattering?
1. Hardness
 2. Brittleness
 3. Malleability
 4. Ductility
- 2-18. What metal property allows a metal to be hammered, rolled, or pressed into various shapes without cracking or breaking?
1. Brittleness
 2. Malleability
 3. Ductility
 4. Elasticity
- 2-19. What metal property allows a metal to be permanently drawn, bent, or twisted into various shapes without breaking?
1. Brittleness
 2. Malleability
 3. Ductility
 4. Elasticity
- 2-20. What metal property allows a metal to carry heat or electricity?
1. Ductility
 2. Fusibility
 3. Conductivity
 4. Malleability
- 2-21. When all other metal properties are equal, what method of joining metals structurally has the greatest advantage?
1. Welding
 2. Brazing
 3. Riveting
 4. Soldering
- 2-22. The intermediate shape of steel that has width greater than twice the thickness and from which sheets are rolled is known by what name?
1. Slab
 2. Bloom
 3. Ingot
 4. Billet
- 2-23. What metal working process is used to make wire?
1. Pressing
 2. Extruding
 3. Hammering
 4. Cold drawing
- 2-24. What metal working process involves the forcing of metal through an opening in a die?
1. Extruding
 2. Cold drawing
 3. Cold working
 4. Cold rolling
- 2-25. While holding a piece of metal against a revolving stone, you see red sparks leave the stone and turn to straw color. This is what type of metal?
1. Low-carbon steel
 2. Nickel steel
 3. Wrought iron
 4. Cast iron

- 2-26. What is the prime characteristic of aluminum?
1. Lightweight
 2. Low melting point
 3. Ease of fabrication
 4. Corrosion-resistant properties
- 2-27. Which of the following processes of joining aluminum alloys produces the strongest joints?
1. Brazing
 2. Forging
 3. Riveting
 4. Heat treating
- 2-28. What is the principal alloying element of aluminum alloy 2024?
1. Zinc
 2. Copper
 3. Manganese
 4. Magnesium
- 2-29. What aluminum alloy should be used when the highest strength is required?
1. 1100
 2. 2014
 3. 5052
 4. 7178
- 2-30. An aluminum alloy containing manganese as the major alloying element is identified by what number?
1. 1035
 2. 2014
 3. 3003
 4. 7010
- 2-31. Alclad is an aluminum alloy with a protective coating of what material?
1. Manganese
 2. Pure aluminum
 3. Zinc chromate
 4. Aluminum oxide
- 2-32. What is the greatest disadvantage in the use of titanium?
1. Strength-to-weight ratio
 2. Tendency to crack when cold-worked
 3. Tendency to back away from or resist the cutting edge of tools
 4. Brittleness after long exposure to temperatures above 1000° F?
- 2-33. The use of copper as a structural material is limited because of what factor?
1. Cost
 2. Great weight
 3. High heat conductivity
 4. High electrical conductivity
- 2-34. What is the principal element added to copper to form brass?
1. Tin
 2. Lead
 3. Zinc
 4. Aluminum
- 2-35. What extinguishing agent should be used on a magnesium fire?
1. Graphite powder
 2. Carbon dioxide
 3. Water
 4. Foam
- 2-36. How many different weights does a Rockwell hardness tester have?
1. One
 2. Two
 3. Three
 4. Four
- 2-37. Each Riehle harness tester is supplied with a diamond penetrator and what size ball penetrator?
1. 1/64
 2. 1/32
 3. 1/16
 4. 1/8
- 2-38. You check the condition of the point of a Barcol hardness tester by using the test disc and find the indicator reading is NOT within the specified range. You should correct this condition by first following what procedure?
1. Grind the point
 2. Install a new point
 3. Adjust the lower plunger guide
 4. Adjust the upper plunger guide nut
- 2-39. You can distinguish a plastic enclosure from a glass enclosure by performing which of the following actions?
1. Checking for a nonringing sound while tapping lightly
 2. Checking the ease with which it is drilled
 3. Checking its reaction to acetone
 4. Checking its reaction to hexane

- 2-40. If long and improper storage has caused the adhesive to deteriorate on a sheet of plastic, the masking paper should be moistened with what chemical?
1. Ether
 2. Xylene
 3. Glass cleaner
 4. Aliphatic naphtha
- 2-41. In various aircraft structural components, what materials are replacing and supplementing metallic materials?
1. Rubber material
 2. Plastic material
 3. Sandwich material
 4. Composite material
- 2-42. What position of a rivet identification code identifies the length of the rivet?
1. 1st
 2. 2d
 3. 3d
 4. 4th
- 2-43. A 5056 rivet is used to join magnesium alloy materials because of which of the following factors?
1. Tensile strength
 2. Cold working
 3. Heat resistance
 4. Corrosion resistance
- 2-44. Which of the following is NOT a factor in the classification of solid rivets?
1. Size
 2. Color
 3. Material
 4. Head shape
- 2-45. Which of the following precautions should you take when using a hi-shear (pin) rivet?
1. Never use them on thick sheets
 2. Never use them on aluminum alloys
 3. Never use them with an aluminum collar
 4. Never use them where the grip length is less than the shank diameter
- 2-46. What type of rivet is used for fastening thick gauge sheets of metal together?
1. Solid
 2. Blind
 3. Shear
 4. Structural
- 2-47. When space on one side is too restricted to properly use a bucking bar, what type of rivet should you use?
1. Flat
 2. Solid
 3. Blind
 4. Hi-shear
- 2-48. What type of fastener is used in an application where a high strength, interference-free fastener is required?
1. Jo-bolt
 2. Lock-bolt
 3. Hi-lok
 4. Rivnut
- 2-49. What type of fastener has high strength and is used in applications where access to only one side of the material is available?
1. Jo-bolt
 2. Lock-bolt
 3. Hi-lok
 4. Rivnut
- 2-50. Which of the following is a distinguishing characteristic of a rivnut?
1. It is solid
 2. It is square
 3. It is oblong
 4. It is hollow
- 2-51. What type of rivet must be used on sealed floatation or pressurized compartments?
1. Open-end
 2. Closed-end
 3. Groove shanked
 4. Externally threaded
- 2-52. Which of the following fasteners has a shear and tensile strength at least equal to the requirements of AN or NAS bolts?
1. Lock bolt
 2. Turnlock
 3. Rivnut
 4. Airloc
- 2-53. What metal is used in the construction of the threaded pins of Hi-lok fasteners?
1. Titanium
 2. Stainless
 3. Anodized 2024-T6 aluminum
 4. Cadmium-plated alloy steel

2-54. Which of the following is NOT a head style of a Jo-bolt?

1. 100-degree flush head
2. Diamond recessed head
3. Hexagon protruding head
4. 100-degree flush millable head

2-55. What type of fastener is used on panels that are removed and reinstalled frequently for maintenance repairs?

1. Hi-lok
2. Jo-bolt
3. Turnlock
4. Structural

ASSIGNMENT 3

Textbook Assignment: "Aircraft Hardware," chapter 3, pages 3-13 through 3-28. "Aircraft Metallic Repair," chapter 4, pages 4-1 through 4-9.

- 3-1. What distance will the stud of a Camloc fastener have to be turned to release it without permitting re-engagement?
1. One-half turn clockwise
 2. One-fourth turn clockwise
 3. One-half turn counterclockwise
 4. One-fourth turn counterclockwise
- 3-2. Which of the following parts is used only on heavy-duty Dzus fasteners?
1. A pin
 2. A stud
 3. A spring
 4. A grommet
- 3-3. When you install a hose between two duct sections, what is the maximum allowable gap between the duct ends?
1. 1/4 inch
 2. 3/8 inch
 3. 3/4 inch
 4. 7/8 inch
- 3-4. A V-band coupling requires what minimum number of turns of safety wire?
1. One
 2. Two
 3. Three
 4. Four
- 3-5. A flat-head pin used in a tie-rod terminal should be secured with what device?
1. A cotter pin
 2. A sheet spring nut
 3. A self-locking nut
 4. A piece of safety wire
- 3-6. A replacement bolt is considered the correct length if at least two threads are extending through the nut?
1. True
 2. False
- 3-7. Aircraft nuts are divided into what two general groups?
1. Self-locking and nonself-locking
 2. Metal insert and fiber insert
 3. High temperature and common
 4. Ferrous and nonferrous
- 3-8. Which of the following is an example of an all-metal self-locking nut?
1. A wing nut
 2. A flexloc nut
 3. An elastic stop nut
 4. An internal wrenching nut
- 3-9. Which of the following types of nuts are designed to be used with cotter pins or safety wire?
1. Check nuts
 2. Plate nuts
 3. Castle nuts
 4. Barrel nuts
- 3-10. When an assembly is frequently removed, which of the following types of nuts should be used?
1. Wing nuts
 2. Shear nuts
 3. Klincher locknuts
 4. Sheet spring nuts
- 3-11. What three types of screws are most commonly used in aircraft construction?
1. Machine, structural, and self-tapping screw
 2. Brazier-head, round-head, and common screws
 3. Self-tapping, Phillips, and common screws
 4. Structural, machine, and pan head screws
- 3-12. Which of the following types of screws are as strong as bolts of the same size?
1. Setscrews
 2. Machine screws
 3. Structural screws
 4. Self-tapping screws

- 3-13. Flush-head screws are available in what degree(s) of head angles?
1. 82° only
 2. 82° and 100° only
 3. 82°, 100°, and 125° only
 4. 82°, 100°, 125°, and 145°
- 3-14. When replacing an original screw in a structure, you should NOT use which of the following screws?
1. A setscrew
 2. A machine screw
 3. A structural screw
 4. A self-tapping screw
- 3-15. Aircraft cables have the center core twisted in one direction and the outer core in the opposite direction for what reason?
1. To make the cable rigid
 2. To make the cable stiffer
 3. To minimize the stretch or set
 4. To allow the strands to expand when cut
- 3-16. A piece of 7 x 19 cable has what total number of wires?
1. 133 wires
 2. 26 wires
 3. 19 wires
 4. 7 wires
- 3-17. Terminal fittings are generally attached to the ends of cables by what method?
1. Swaging
 2. Welding
 3. Splicing
 4. Soldering
- 3-18. The size of a cable is determined by which of the following factors?
1. Lay
 2. Tension
 3. Diameter
 4. Strength
- 3-19. The turnbuckle is used to make what type of cable adjustments?
1. Minor adjustments to cable length only
 2. Minor adjustments to cable tension only
 3. Minor adjustments to cable length and tension
 4. To adjust cable threads
- 3-20. Adjustable connector links are used in what type of cable assemblies?
1. Very long cable assemblies
 2. Very short cable assemblies
 3. Thin cable assemblies
 4. Stretch cable assemblies
- 3-21. How many different types of cable guides are used throughout an aircraft?
1. Two
 2. Three
 3. Four
 4. Five
- 3-22. A fairlead may be used to minimize cable whipping and for what other purpose?
1. Minimize sticking
 2. Minimize binding
 3. Minimize slacking
 4. Minimize vibration in long cable runs
- 3-23. A grommet is manufactured from what material?
1. Rubber
 2. Aluminum
 3. Copper
 4. Felt
- 3-24. What device is used on cables or rods that must move through a pressurized bulkhead?
1. O-ring
 2. Grommet
 3. Pressure seal
 4. Back-up ring
- 3-25. What device changes cable direction and allows a cable to move with minimum friction?
1. Pulley
 2. Sector
 3. Quadrant
 4. Bell crank
- 3-26. A connector assembly consists of how many different parts?
1. One
 2. Two
 3. Three
 4. Four

- 3-27. What device provides a means of fastening a wire to a terminal stud?
1. Connector
 2. Bonding wire
 3. Terminal
 4. Static discharger
- 3-28. What type of terminal is generally recommended for use on naval aircraft?
1. Crimped-type
 2. Soldered
 3. Twist on
 4. Fused-type
- 3-29. What type of terminals are usually used in emergencies only?
1. Crimped-type
 2. Soldered
 3. Twist on
 4. Fused-type
- 3-30. What type of connection is used to connect all metal parts of an aircraft to complete an electrical unit?
1. Terminal
 2. Static
 3. Bonding
 4. Fused
- 3-31. What component allows for the continuous satisfactory operation of onboard navigation and radio communication systems?
1. Bonding wires
 2. Connectors
 3. Terminals
 4. Static dischargers
- 3-32. What factor accounts for the majority of all fastener problems?
1. Fatigue failure
 2. Improper material
 3. Cross-threading
 4. Corrosive breakdown
- 3-33. Torque values must be followed unless the MIM or structural repair manual for the specific aircraft requires a specific torque for a given nut.
1. True
 2. False
- 3-34. Cotter pins are used to secure which of the following devices?
1. Bolts only
 2. Nuts only
 3. Screws only
 4. Bolts, nuts, and screws
- 3-35. What type of safety wire is used in high-temperature areas?
1. Bailing wire
 2. Brass wire
 3. Annealed copper wire
 4. Annealed, corrosion-resistant wire
- 3-36. What type of safety wire is used on valves and levers used for emergency operation of aircraft equipment?
1. Copper wire
 2. Brass wire
 3. Bailing wire
 4. Corrosion-resistant wire
- 3-37. How many different methods are used for safetying a turnbuckle?
1. One
 2. Two
 3. Three
 4. Four
- 3-38. The clip-locking method is the preferred method for safetying a turnbuckle?
1. True
 2. False
- 3-39. How many times, if any, can a turnbarrel lock clip be reused?
1. One time
 2. Two times
 3. Three times
 4. It cannot be reused
- 3-40. How many pieces of safety wire are used when securing a turnbuckle using the wire-wrapped method?
1. One
 2. Two
 3. Three
 4. Four

- 3-41. When you use the wire-wrapped method on a turnbuckle, each wire is wrapped how many times around the shank?
1. One
 2. Two
 3. Three
 4. Four
- 3-42. A ball peen hammer is sometimes referred to as what type of hammer?
1. Machinist hammer
 2. Mechanics hammer
 3. Forging hammer
 4. Striking hammer
- 3-43. What is the domed end of the ball peen hammer called?
1. Face
 2. Head
 3. Peen
 4. Round
- 3-44. What weight ball peen hammer will suffice for most work?
1. 2-pound and 5-ounce weight
 2. 12-ounce and 1 1/2-pound weight
 3. 8-ounce and 2-pound weight
 4. 6-ounce and 1-pound weight
- 3-45. Mallet heads are constructed from which of the following materials?
1. Brass only
 2. Plastics only
 3. Rawhide only
 4. Brass, plastics, and rawhide
- 3-46. Special rivet sets, called "draw sets" are used to "draw up" the pieces of metal being riveted in order to eliminate any opening between them before the rivet is bucked.
1. True
 2. False
- 3-47. The size and weight of the bucking bar to be used on a particular riveting job is determined by which of the following factors?
1. The size of the rivets to be driven only
 2. The alloy of the rivets to be driven only
 3. The size and alloy of the rivets to be driven
 4. The location of the rivets to be driven
- 3-48. What size Cleco skin fastener is identified by its brass color code?
1. 1/8 in.
 2. 3/16 in.
 3. 5/32 in.
 4. 1/4 in.
- 3-49. Machine countersinking is used to flush rivet sheets of what minimum thickness?
1. 0.064 in.
 2. 0.060 in.
 3. 0.055 in.
 4. 0.048 in.
- 3-50. Which of the following power tools is used to smooth countersunk rivet heads that protrude?
1. Rotary-rivet cutter
 2. Pneumatic drill with grinding wheel
 3. Dimple countersinking tool
 4. Rivet-head shaver
- 3-51. What component must be used on all pneumatic rivet sets to prevent the set from being discharged from the rivet gun when the trigger is pulled?
1. Retaining setscrews
 2. Cylinder safety clip
 3. Retainer springs
 4. Barrel retention key
- 3-52. Which of the following types of pneumatic riveters is in general use in the Navy?
1. One-shot gun only
 2. Corner riveter only
 3. Fast-hitting gun only
 4. One-shot gun, corner riveter, and fast-hitting gun
- 3-53. Which of the following rivet guns is preferred when driving medium-size, heat-treated rivets that are in accessible places?
1. Fast-hitting gun
 2. Slow-hitting gun
 3. One-shot gun
 4. Squeeze riveter
- 3-54. Which of the following is a common error made by the inexperienced person when using portable drills?
1. Incorrect angle to the work
 2. Excessive pressure on the drill
 3. Both 1 and 2 above
 4. Failure to lubricate prior to use

3-55. When dimple countersinking, what is the combined process that occurs to the metal to form a dimple?

1. Bending and stretching
2. Machining and burring
3. Heating and drilling
4. Shearing and forming

ASSIGNMENT 4

Textbook Assignment: "Aircraft Metallic Repair," chapter 4, pages 4-9 through 4-52.

- 4-1. The dies of hot dimpling machines are maintained at a specific temperature by which of the following devices?
1. Hot air blowers
 2. Steam generator
 3. Electric heaters
 4. Hot oil vats
- 4-2. The hot dimpling squeezer is capable of working all material gauges up to and including which of the following measurements?
1. 0.084 of an inch
 2. 0.091 of an inch
 3. 0.098 of an inch
 4. 0.102 of an inch
- 4-3. What is likely to occur when dimpling a strip of material by using excessive pressure?
1. The strip tends to form a convex shape
 2. The strip tends to form a concave shape
 3. The strip tends to form a channel shape
 4. Excessive pressure is required to keep the strip straight and flat
- 4-4. Squaring shears can be used to perform all EXCEPT which of the following cutting operations?
1. Squaring
 2. Multiple cutting
 3. Cutting to a line
 4. Notch cutting
- 4-5. Which of the following types of shears are portable and power operated?
1. Throatless shears
 2. Unishears
 3. Hand bench shears
 4. Squaring shears
- 4-6. Before you use the bar folder, which of the following adjustments must be made?
1. Width of the fold only
 2. Sharpness of the fold only
 3. Angle of the fold only
 4. Width, sharpness, and angle of the fold
- 4-7. Which of the following sheet metal bending equipment has a series of removable fingers of varying widths?
1. A bar folder
 2. A cornice break
 3. A box and pan break
 4. A bench vise
- 4-8. Which of the following materials should you **NEVER** attempt to bend in a brake?
1. Rods only
 2. Wire only
 3. Spring steel sheets only
 4. Rods, wire, and spring steel sheets
- 4-9. To allow the lines to stand out more clearly when laying out sheet metal patterns, you should use which of the following items?
1. Layout fluid
 2. Felt tip marker
 3. Graphite pencil
 4. Ball-point pen
- 4-10. Lines at a known angle or parallel to the straight edge of the sheet of material can be made by marking points from a combination square held firmly against the straight edge.
1. True
 2. False
- 4-11. When marking or drawing lines on aluminum or magnesium, which of the following should be removed to prevent corrosion?
1. Masking tape
 2. Lead pencil marks
 3. Scriber lines
 4. Finger prints
- 4-12. Which of the following terms is used to describe the amount of material consumed in making a bend?
1. Mold line
 2. Bend tangent line
 3. Bend allowance
 4. Bend line

- 4-13. What term is used to describe the longer part of a formed angle?
1. Flange
 2. Flat
 3. Leg
 4. Arm
- 4-14. The term “setback” is used to describe the distance between which of the following two points?
1. Bend tangent line and the mold line
 2. Base measurement and the bend allowance
 3. Bend radius and material thickness
 4. Bend tangent line and the mold point
- 4-15. What is used to back up metal when hand forming many different curves, angles, and seams?
1. A vise
 2. Stakes
 3. Cornice brake
 4. Stake holder
- 4-16. When hand forming metal in a vise, using a hammer, the concave surfaces are formed by stretching the material over a form block and convex surfaces are formed by shrinking the material in the same manner?
1. True
 2. False
- 4-17. Which of the following machines is used to form sheet metal into cylindrical or conical shapes?
1. A bar folder
 2. A slip-roll forming machine
 3. A lathe turning machine
 4. A rotary forming machine
- 4-18. Which of the following machines forms sheet metal by using beading rolls, turning rolls, wiring rolls, crimping rolls, and burring rolls?
1. A bar folder
 2. A slip-roll forming machine
 3. A rotary machine
 4. A lathe turning machine
- 4-19. Which of the following rotary machine-rolling operations is generally the most difficult to perform?
1. Wiring
 2. Beading
 3. Burring
 4. Crimping
- 4-20. What is the minimum rivet diameter to be used on structural parts, control parts, wing coverings, or similar parts of the aircraft?
1. 1/8 of an inch
 2. 3/16 of an inch
 3. 5/64 of an inch
 4. 3/32 of an inch
- 4-21. The length of the rivet should equal the sum of the thickness of the metal to be riveted plus how many times the diameter of the rivet?
1. 1 times the diameter
 2. 1 1/2 times the diameter
 3. 1 1/4 times the diameter
 4. 2 times the diameter
- 4-22. What is the distance between the rows of rivets called when two or more rows are used?
1. Edge distance
 2. Rivet spacing
 3. Transverse pitch
 4. Rivet diameter
- 4-23. To properly drill a hole for a 1/8-inch rivet, you should use what number drill bit?
1. No. 30
 2. No. 41
 3. No. 21
 4. No. 11
- 4-24. What is the decimal equivalent drill size for drill number “P”?
1. .1590
 2. .3230
 3. .2570
 4. .3860
- 4-25. Flush rivets are made with heads of several different angles. What is the standard rivet head angle for all Navy aircraft?
1. 90°
 2. 95°
 3. 100°
 4. 110°
- 4-26. The upset head or “bucktail” of a driven flush rivet should be 1 1/2 times the original diameter of the rivet shank in width and 1/2 times the original diameter in height.
1. True
 2. False

- 4-27. You are using a CP350 blind rivet pull tool and want to change the rivets from universal heads to countersunk heads without changing the rivet diameter. Which of the following blind rivet pull tool components will you need to change?
1. The outer anvil
 2. The chuck jaws
 3. The inner anvil
 4. The inner anvil thrust bearing
- 4-28. When installing a 5/32 diameter rivet, what is the correct shift valve operating pressure for the CP350 blind rivet pull tool?
1. 30 to 31 psi
 2. 46 to 47 psi
 3. 66 to 67 psi
 4. 35 to 41 psi
- 4-29. The installation, inspection, and removal procedures for cherrylock rivets are basically the same for which of the following types of rivets?
1. Hi-shear
 2. Solid
 3. Huck
 4. Flush
- 4-30. Visual inspection of a self-plugging rivet (mechanical lock) shows the locking collar pin breaking off below the surface of the manufactured head. This is an indication of what discrepancy?
1. Proper rivet grip length
 2. Excessive rivet grip length
 3. Incorrect rivet gun air pressure
 4. Insufficient rivet grip length
- 4-31. Which of the following conditions cause the most damage to an aircraft airframe?
1. Stress and fatigue
 2. Combat damage and collision
 3. Corrosion and heat
 4. All of the above
- 4-32. What type of airframe damage is more noticeable as the operating time of the aircraft accumulates?
1. Corrosion
 2. Fatigue
 3. Stress
 4. Heat
- 4-33. What inspection method would you use for internal structures and inaccessible areas to avoid disassembly of components?
1. Zone inspection
 2. Hardness testing
 3. Borescope inspection
 4. Nondestructive inspection
- 4-34. While performing a repair of the airframe, you discover a conflict of procedures between the aircraft specific structural repair manual and the *General Manual for Structural Repair*. What should you do?
1. Follow the procedures in the aircraft specific manual, because it takes precedence
 2. Ask Quality Assurance Division for assistance in interpreting the procedure
 3. Follow the procedures in the *General Manual for Structural Repair*, because it applies to all aircraft
 4. Stop all maintenance and contact the Type Commander for engineering assistance
- 4-35. What classification of damage repair can be performed by installing a reinforcement or patch to bridge the damaged portion of a part?
1. Negligible damage
 2. Damage requiring replacement
 3. Damage repairable by patching
 4. Damage repairable by insertion
- 4-36. What information is normally included on the repair materials chart of an aircraft structural repair manual?
1. Drawing number and part description
 2. Location of repair diagram
 3. Type of material and gauge
 4. All of the above
- 4-37. When several replacement parts need to be fabricated, which of the following items should you use to speed production time and ensure a high degree of uniformity?
1. Templates
 2. Blueprints
 3. Drawings
 4. Designs

- 4-38. A skin repair to a semicritical area of an aircraft requires what percentage of the damaged area's original strength to be replaced?
1. 50%
 2. 60%
 3. 70%
 4. 80%
- 4-39. The edges of a lap patch are normally chamfered to what degree of angle?
1. 35°
 2. 45°
 3. 55°
 4. 60°
- 4-40. Generally, when fabricating a flush patch, you should have what maximum clearance between the skin and the filler?
1. 1/8 in.
 2. 1/4 in.
 3. 1/32 in.
 4. 1/16 in.
- 4-41. When performing a flush access door installation to attach the cover plate to the doubler, you should use what type of fasteners?
1. Rivnuts
 2. Hi-lok rivets
 3. Machine screws
 4. Flush head jo-bolts
- 4-42. When manufacturing a section of sheet metal for replacement (using the old section as a template), you should drill the rivet holes in the new sheet in what direction?
1. From the center to the outside
 2. From the outside to the center
 3. From the top to the bottom
 4. Diagonally from corner to corner
- 4-43. When an aircraft skin is being replaced without the use of a template, which of the following methods of marking the new skin should NOT be used to duplicate the rivet holes in the old section?
1. A soft pencil
 2. A hole finder
 3. A transfer punch and hammer
 4. A scribe
- 4-44. Which of the following airframe structural members is designed to stiffen the skin and aid in maintaining the contour of the structure?
1. Spars
 2. Stringers
 3. Ribs
 4. Bulkheads
- 4-45. What is the minimum length for a reinforced splice?
1. Four times the width of the leg of the stringer for each side of the damaged area
 2. Two times the length of the filler splice
 3. Four times the length of the leg of the stringer for each side of the damaged area
 4. Two times the width of the filler splice
- 4-46. Which of the following airframe structural members are primarily designed to take bending loads imposed on the wing or other airfoils?
1. Ribs
 2. Stringers
 3. Spars
 4. Longerons
- 4-47. Which of the following airframe components is the principal chordwise structural member in the wing, stabilizers, and other airfoils?
1. Stringers
 2. Bulkheads
 3. Ribs
 4. Spars
- 4-48. Any major vertical structural member of a semimonocoque fuselage, hull, or float may be considered as what structural component?
1. Stringer
 2. Bulkhead
 3. Longeron
 4. Spar
- 4-49. Which of the following airframe components is a fore-and-aft member of the fuselage or nacelle and is usually continuous across a number of points of support, such as frames?
1. Ribs
 2. Bulkheads
 3. Stringers
 4. Longerons

- 4-50. Airframe fuel system maintenance is the responsibility of which of the following aviation rating work centers?
1. AD only
 2. AM only
 3. AO only
 4. AD, AM, and AO
- 4-51. What is the most commonly used type of self-sealing fuel cells?
1. Self-sealing cell (standard construction)
 2. Self-sealing cell (nonstandard construction)
 3. Rubber-type bladder cell
 4. Nylon-type bladder cell
- 4-52. How many primary layers of material are used in the construction of a self-sealing fuel cell?
1. Two
 2. Three
 3. Four
 4. Five
- 4-53. Buna rubber is an artificial substitute for crude or natural rubber. Which of the following types is used as fuel cell inner liner material and is not affected by petroleum fuels?
1. Buna L
 2. Buna N
 3. Buna R
 4. Buna S
- 4-54. What is fitted to some baffles inside fuel cells to control the direction of fuel flow between compartments or interconnecting cells?
1. Flapper valves
 2. One-way check valves
 3. Fuel pumps
 4. Fuel siphon valves
- 4-55. What is the main advantage of a bladder-type fuel cell over a self-sealing fuel cell?
1. Fewer inspections
 2. Thicker wall construction
 3. Slightly smaller than the aircraft cavity
 4. Less total weight
- 4-56. When applying the nylon barrier of a rubber-type bladder fuel cell, you should NOT use which of the following methods of application?
1. Swab
 2. Roller
 3. Spray
 4. Swab
- 4-57. The milled skins of an integral fuel cell are normally fastened to the aircraft by what means?
1. Pins
 2. Rivets
 3. Bolts
 4. Screws
- 4-58. A fuel leak that reappears 30 minutes after it is wiped dry is classified as what category of leakage?
1. Seep
 2. Slow seep
 3. Heavy seep
 4. Running leak
- 4-59. What is the first step you should take to stop a fuel leak?
1. Reinject sealant around the perimeter of the cell
 2. Replace the O-rings under all fasteners in the leak area
 3. Retorque all fasteners 6 inches on either side of the leak area
 4. Replace the Stat-O-Seal washers under all fasteners in the leak area
- 4-60. To allow the gun piston to return before another cycle can begin, the trigger of a sealant injector gun must be released approximately how often?
1. Every 30 seconds
 2. Every 45 seconds
 3. Every 2 minutes
 4. Every 3 minutes
- 4-61. To pressure test a repair made on an integral fuel cell, you should use what type of gas?
1. Helium
 2. Oxygen
 3. Dry air
 4. Nitrogen

ASSIGNMENT 5

Textbook Assignment: "Aircraft Nonmetallic Repair," chapter 5, pages 5-1 through 5-40. "Nondestructive Inspections, Welding, and Heat Treatment," chapter 6, pages 6-1 through 6-28.

- 5-1. For aircraft applications, all EXCEPT which of the following features is an advantage of plastic over glass?
1. Its ease of repair
 2. Its ease of fabrication
 3. Its lightness in weight
 4. Its ability to resist scratches
- 5-2. What term refers to small surface fissures that develop on plastic materials?
1. Hazing
 2. Glazing
 3. crazing
 4. Cracking
- 5-3. Upon finding a section of plastic material that is crazed, what action, if any, should you take to correct the problem?
1. Buff it with polish
 2. Wipe it with naphtha
 3. Rub it with turpentine
 4. None
- 5-4. By sanding or buffing a plastic surface too long or too vigorously in one spot, you can cause which of the following problems?
1. Cracking or crazing
 2. Softening or burning
 3. Bleaching or glazing
 4. Discoloration or hazing
- 5-5. Standard buffing compounds on transparent plastics are usually composed of very fine alumina in combination with which of the following materials?
1. Wax only
 2. Tallow only
 3. Wax or tallow only
 4. Wax, tallow, or grease
- 5-6. When you mount plastic panels, what is the minimum prescribed thickness for the packing material?
1. 1/16 in.
 2. 1/8 in.
 3. 3/16 in.
 4. 1/4 in.
- 5-7. When repairing minor surface damage to reinforced plastics, you should apply which of the following materials to the damaged area?
1. Two coats of catalyzed resin heated to 112°F
 2. One or more coats of room-temperature catalyzed resin
 3. Three coats of paste composed of catalyzed resin and nylon fibers heated to 137°F
 4. One coat of room-temperature paste composed of catalyzed resin and short glass fibers
- 5-8. When using the stepped method to repair ply damage to solid laminates, which of the following procedures should you observe to ensure maximum strength of the repaired area?
1. Cut the replacement glass fabric pieces to an exact fit with the weave running in the same direction as the existing plies
 2. Ensure that the replacement pieces are slightly thicker than the existing plies
 3. Install the replacement pieces with the fabric plies overlapping the existing plies
 4. Replace every other piece of damaged fabric
- 5-9. A reinforced plastic component with a honeycomb core has damage that extends completely through one facing and into the core. What is the preferred method of repair for this component?
1. Plugged
 2. Stepped
 3. Scarfed
 4. Delaminated ply
- 5-10. The scarfed method is normally used to repair small punctures in reinforced plastics up to what maximum dimension?
1. 3 or 4 in.
 2. 5 or 6 in.
 3. 7 or 8 in.
 4. 9 or 10 in.

- 5-11. When repairing a puncture in a piece of reinforced plastic using the stepped method, what material should you use to cover the repair area while it cures?
1. Graphite grease
 2. Petroleum jelly
 3. Cellophane sheeting
 4. Aluminum barrier paper
- 5-12. Rain erosion-resistant coating MIL-C-7439, Class II, has an additional surface treatment included in the kit for what purpose?
1. To absorb radar waves
 2. To minimize radio noise
 3. To reflect ultraviolet light
 4. To lower its internal working temperature
- 5-13. A sandwich construction material is delaminated with facing-to-core voids of less than 2.5 inches in diameter. Which of the following repair methods should you use?
1. Apply a flush patch by using thick cloth soaked in Thermofoam 706
 2. Apply a coat of Thermofoam 706 to the surface and cover it with Kraft paper
 3. Inject a nonexpandable forming resin into the drilled holes over the void area with a syringe
 4. Inject an expandable forming resin into the drilled holes over the void area with a pressure-type caulking gun
- 5-14. The corners of a rectangular cutout must have what minimum radius?
1. 1/8 in.
 2. 1/4 in.
 3. 3/8 in.
 4. 1/2 in.
- 5-15. You are repairing a balsa wood core component. When you use two rows of rivets, the inner patch should overlap the hole in the core by what prescribed amount?
1. 1 in.
 2. 2 in.
 3. 3 in.
 4. 4 in.
- 5-16. Which of the following components of SH-60B aircraft are manufactured from advanced composite materials?
1. The gearboxes
 2. The scarf joints
 3. The upper canopies
 4. The horizontal stabilizers
- 5-17. Which of the following factors is a disadvantage of advanced composite materials over metals?
1. Repair capability
 2. Expense of materials
 3. Corrosion resistance
 4. Weight of the material
- 5-18. In an advanced composite material, what is the homogeneous resin binder known as?
1. Pulp
 2. Paste
 3. Matrix
 4. Laminate
- 5-19. The damage to advanced composite materials may be categorized in which of the following ways?
1. Natural
 2. Organic or physical
 3. Organic or environmental
 4. Physical or environmental
- 5-20. When performing a tap test on advanced composite materials, you should use a hammer that weighs about the weight of a U.S. 50-cent coin.
1. True
 2. False
- 5-21. A section of advanced composite material has water trapped in the honeycomb area. This is what class of repairable damage?
1. Class IV
 2. Class V
 3. Class VI
 4. Class VII
- 5-22. The drill motors used on advanced composite materials should be capable of what maximum speed?
1. 5,000 rpm
 2. 6,000 rpm
 3. 7,000 rpm
 4. 8,000 rpm

- 5-23. When working with advanced composite materials, which of the following personnel hazards should be your principal concern?
1. Contact with the dust on your hands
 2. Contact with the matrix on your clothing
 3. Inhalation of airborne dust and fibrous particles
 4. Inhalation of fumes before the matrix has completely cured
- 5-24. The flashpoints of solvents and resins for composite materials are usually around what minimum temperature?
1. 500°F
 2. 200°F
 3. 300°F
 4. 400°F
- 5-25. On Navy aircraft, the paint system is identified with a stencil or decal at what location?
1. On the right side of the aft fuselage
 2. On the left side of the aft fuselage
 3. On the right side of the upper wing
 4. On the left side of the upper wing
- 5-26. Which of the following statements pertaining to aircraft stripping is NOT correct?
1. The stripper should be spread in a thin coat
 2. The stripper should be applied with fiber brushes
 3. The aircraft should be located outside if possible
 4. The aircraft's joints or seams in the stripping area should be masked
- 5-27. Paint feathering may be accomplished with all EXCEPT which of the following items?
1. 240 grit aluminum oxide cloth
 2. 280 grit aluminum oxide cloth
 3. 320 grit aluminum oxide cloth
 4. Flap brush
- 5-28. After epoxy-polyamide primer is sprayed, it should be allowed to air dry for what minimum amount of time?
1. 15 min
 2. 30 min
 3. 45 min
 4. 60 min
- 5-29. You mixed aliphatic polyurethane paint and did not use it for more than 3 hours. Which of following problems will occur if you try to rethin the paint?
1. Fish eyes
 2. Dry spots only
 3. Orange peel only
 4. Dry spots or orange peel
- 5-30. The epoxy-polyamide topcoat is mixed in what ratio of (a) pigmented component to (b) clear resin?
1. (a) One (b) one
 2. (a) One (b) two
 3. (a) Two (b) one
 4. (a) Two (b) three
- 5-31. To obtain excellent adhesion, elastomeric rain erosion-resistant coating, MIL-C-7439, should be allowed to dry for what minimum number of days?
1. 5 days
 2. 6 days
 3. 7 days
 4. 8 days
- 5-32. When you lay out the blue border that outlines the entire design of the national insignia, the border should be what fractional part of the radius of the blue circle in width?
1. 1/16
 2. 1/8
 3. 3/16
 4. 1/4
- 5-33. A pressure-feed spray gun is designed to operate at (a) what fluid volume and (b) what air pressure?
1. (a) Low (b) low
 2. (a) Low (b) high
 3. (a) High (b) low
 4. (a) High (b) high
- 5-34. Prior to use, what component of a spray gun should be removed and treated with oil?
1. The air valve packing
 2. The fluid needle spring
 3. The fluid needle packing
 4. The trigger bearing screw

- 5-35. When spraying epoxy-polyamide and polyurethane finishes, you should hold the gun at what prescribed distance from the work?
1. 4 to 8 in.
 2. 6 to 10 in.
 3. 8 to 12 in.
 4. 10 to 14 in.
- 5-36. Which of the following spray gun problems causes dusting?
1. Excessive air pressure
 2. Excessive fluid pressure
 3. Insufficient air pressure
 4. Insufficient fluid pressure
- 5-37. Which of the following types of sealants set and cure by evaporation of the solvent?
1. Drying sealants
 2. Curing sealants
 3. Pliable sealants
 4. Flexible sealants
- 5-38. You should apply a sealant to a faying surface by what method?
1. A brush
 2. Spraying
 3. A spatula
 4. Injection
- 5-39. What type of sealing compound, MIL-S-81733, is applied with a spray gun?
1. Type I
 2. Type II
 3. Type III
 4. Type IV
- 5-40. What manual covers the theory and general applications of various methods of NDI?
1. NAVAIR 01-1A-12
 2. NAVAIR 01-1A-16
 3. NAVAIR 01-1A-17
 4. NAVAIR 01-1A-20
- 5-41. Currently active NDI technicians are required to be recertified at least how often?
1. Every 5 years
 2. Every 2 years
 3. Every 3 years
 4. Every 4 years
- 5-42. NDI operators must use the NDI method(s) for which they are certified at least how often?
1. Once a month
 2. Twice a month
 3. Once a quarter
 4. Twice a quarter
- 5-43. What command has cognizance over the NDI program?
1. NADOC
 2. NADEP
 3. NAESU
 4. NAVAIR
- 5-44. Aircraft controlling custodians have all EXCEPT which of the following NDI program responsibilities?
1. Designating NDI specialist as required
 2. Designating an NDI program manager
 3. Providing NDI training for NADEPs as requested
 4. Ensuring that NDI equipment, laboratories, and personnel are audited as required
- 5-45. The detection of flaws or defects in material with a high degree of accuracy and reliability by the use of NDI methods depends primarily on which of the following factors?
1. The availability of a trained and experienced technician
 2. The availability of a large and well-equipped facility
 3. The type of material being inspected
 4. The detection method used
- 5-46. You are performing a process that consists of inducing a magnetic field into a part and applying magnetic particles in a liquid suspension or dry powder. What type of NDI inspection are you conducting?
1. Ultrasonic
 2. Radiographic
 3. Eddy current
 4. Magnetic particle
- 5-47. Which of the following magnetization methods are used in magnetic particle inspections?
1. Linear only
 2. Circular only
 3. Circular and longitudinal only
 4. Linear, circular, and longitudinal

- 5-48. To magnetize both the inside and outside of parts that are hollow or tubelike, you should place them on a copper bar and pass current through them.
1. True
 2. False
- 5-49. The particles used in magnetic particle testing must possess which of the following qualities?
1. High permeability and high retentivity
 2. High permeability and low retentivity
 3. Low permeability and high retentivity
 4. Low permeability and low retentivity
- 5-50. Concerning a radiographic NDI inspection, all EXCEPT which of the following statements are correct?
1. It is one of the most expensive
 2. It can be used on nonmetallic materials
 3. It is the least sensitive method of crack detection
 4. It should only be used on items that are accessible or favorably oriented
- 5-51. If the whole body of a person is exposed to a very large dose of radiation, what would most likely be the result?
1. Death
 2. Cancer
 3. Leukemia
 4. Skin damage
- 5-52. Ultrasonic NDI inspection information is displayed by what means?
1. Video tape
 2. Photographic film
 3. Cassette tape recorder
 4. Cathode-ray tube screen
- 5-53. What ultrasonic NDI inspection method projects a beam of vibrations that travels along or just below the surface of the material?
1. Immersion
 2. Angle beam
 3. Surface wave
 4. Straight beam
- 5-54. What type of eddy current probe or coil is used on plates, sheets, or irregular-shaped parts?
1. Inside probe
 2. Surface probe
 3. Encircling coil
 4. Bobbin-type coil
- 5-55. The developer used in a dye penetrant NDI inspection serves what purpose?
1. It neutralizes the dye
 2. It speeds the drying of the penetrant
 3. It helps draw any trapped penetrant from the discontinuities
 4. It aids the penetrant in filling any discontinuities that are below the surface of the material
- 5-56. Training programs and testing facilities for those personnel desiring to qualify as aircraft welders are available at which of the following activities?
1. NADOC
 2. NADEP
 3. NAESU
 4. NATTC
- 5-57. The groups of metals for which separate and distinct welding certifications are required are specified in what manual?
1. NAVAIR 01-1A-11
 2. NAVAIR 01-1A-12
 3. NAVAIR 01-1A-16
 4. NAVAIR 01-1A-34
- 5-58. In the oxyacetylene gas welding process, the welding torch is used for which of the following purposes?
1. To provide a clamping device for the gas tubes and rods
 2. To direct the flame against the metal only
 3. To mix the gases in proper proportions only
 4. To direct the flame against the metal and mix the gases in proper proportions
- 5-59. Which of the following statements pertaining to oxygen is NOT correct?
1. It is flammable
 2. It is colorless
 3. It is tasteless
 4. It is heavier than air
- 5-60. On a single-stage oxygen regulator, the outlet pressure gauge provides what indication?
1. The working pressure
 2. The mixing ratio of the gases
 3. The amount of oxygen in the cylinder
 4. The amount of acetylene in the cylinder

- 5-61. When burned with oxygen, acetylene produces a flame in what temperature range?
1. 1,200 to 3,300°F
 2. 2,850 to 4,500°F
 3. 5,700 to 6,300°F
 4. 6,150 to 7,500°F
- 5-62. The oxygen pressure is much higher than the acetylene pressure in what type of oxyacetylene welding torch?
1. The jet type
 2. The injector type
 3. The high-pressure type
 4. The equal-pressure type
- 5-63. On oxyacetylene welding equipment, what color and thread type identifies the (a) oxygen hose and (b) acetylene hose?
1. (a) Green with right-handed threads
(b) Red with left-handed threads
 2. (a) Green with left-handed threads
(b) Red with right-handed threads
 3. (a) Black with right-handed threads
(b) Green with left-handed threads
 4. (a) Red with left-handed threads
(b) Black with right-handed threads
- 5-64. What type of flame should you use when welding bronze with an oxyacetylene welding rig?
1. Neutral
 2. Oxidizing
 3. Nitrating
 4. Carburizing
- 5-65. If you light the acetylene only on an oxyacetylene welding torch, the flame will be what color?
1. Red
 2. Blue
 3. Yellow
 4. Orange
- 5-66. A torch flashback can be caused by all EXCEPT which of the following factors?
1. Loose connections
 2. Improper pressures
 3. Overheating of the torch
 4. Touching the tip of the torch against the work
- 5-67. When torch welding, you should hold the white cone of the flame at what prescribed distance from the surface of the metal?
1. 1/8 in.
 2. 1/4 in.
 3. 3/8 in.
 4. 1/2 in.
- 5-68. What welding method should you use when welding material more than 1/8-inch thick?
1. Puddle
 2. Ripple
 3. Backhand
 4. Forehand
- 5-69. Which of the following weld joints is made by joining two members located approximately at right angles to each other?
1. Tee
 2. Edge
 3. Butt
 4. Corner
- 5-70. Which of the following weld joints is made by welding two or more parallel members?
1. Tee
 2. Edge
 3. Butt
 4. Corner
- 5-71. Which of the following weld joints is made by welding two plates whose surfaces are 90° of each other at the joint?
1. Tee
 2. Edge
 3. Butt
 4. Corner
- 5-72. Which of the following weld joints is made by joining two pieces of material edge to edge without any overlapping?
1. Tee
 2. Edge
 3. Butt
 4. Corner
- 5-73. In the GTA welding process, the shielding gas is used for which of the following purposes?
1. To reflect the heat from the electrode
 2. To produce a more concentrated heat to the weld zone
 3. To lay the weld bead faster and lengthen the weld arc
 4. To protect the molten weld metal from atmospheric contamination

5-74. In the GTA welding process, the greatest concentration of heat at the electrode results from what arrangement of (a) current and (b) polarity?

1. (a) dc (b) reverse
2. (a) dc (b) straight
3. (a) ac (b) reverse
4. (a) ac (b) straight

5-75. You should use water-cooled GTA welding torches when welding with current above what prescribed amperage?

1. 50 amp
2. 100 amp
3. 150 amp
4. 200 amp

ASSIGNMENT 6

Textbook Assignment: "Nondestructive Inspections, Welding, and Heat Treatment," chapter 6, pages 6-29 through 6-45. "Aircraft Wheels, Tires, and Tubes," chapter 7, pages 7-1 through 7-24.

- 6-1. What is the most popular gas used in the GTA welding process?
1. Radon
 2. Argon
 3. Hydrogen
 4. Nitrogen
- 6-2. To strike the arc using an ac GTA welding machine, you should angle the end of the torch toward the work so that the electrode is at what prescribed distance above the plate?
1. 1/8 in.
 2. 1/4 in.
 3. 3/8 in.
 4. 1/2 in.
- 6-3. In the GMA welding process, what factor determines the melting rate of the filler wire?
1. The speed rate of the welder
 2. The diameter of the filler wire
 3. The level of the welding current
 4. The size of the area to be welded
- 6-4. When you are GMA welding with a constant-voltage power source, what condition will occur as a result of any changes in the length of the welding arc?
1. The shielding gases will automatically shut off
 2. The welding current will automatically change
 3. The wire driven mechanism will automatically adjust the feed speed
 4. The welding gun will automatically stop delivering the electrode until the problem has been resolved
- 6-5. In the GMA welding process, what type of shielding gas is preferred for welding thick materials?
1. Neon
 2. Argon
 3. Helium
 4. Hydrogen
- 6-6. In the GMA welding process, what basic welding position is preferred for most joints because it improves the molten metal flow, bead contour, and gives better gas protection?
1. Flat
 2. Vertical
 3. Overhead
 4. Horizontal
- 6-7. For safety purposes, when welding cables must reach some distance from the machine, you should run the cables overhead, if possible.
1. True
 2. False
- 6-8. What term refers to metals with iron bases?
1. Nonferrous
 2. Ferrous
 3. Ionic
 4. Alloy
- 6-9. The heat-treatment cycle includes all EXCEPT which of the following events?
1. Soaking
 2. Heating
 3. Cooling
 4. Misting
- 6-10. When steel parts have an uneven cross section, what factor determines the soaking period?
1. Its total weight
 2. Its lightest section
 3. Its heaviest section
 4. Its overall length and width
- 6-11. Which of the following heat-treatment processes is used to relieve the strains induced during hardening?
1. Normalizing
 2. Annealing
 3. Tempering
 4. Case hardening

- 6-12. Which of the following heat-treatment processes is used to reduce residual stresses or induce softness?
1. Normalizing
 2. Annealing
 3. Tempering
 4. Case hardening
- 6-13. Which of the following heat-treatment processes is used for parts that require a wear-resistant surface?
1. Normalizing
 2. Annealing
 3. Tempering
 4. Case hardening
- 6-14. At ordinary temperatures, the carbon in steel exists in the form of iron carbide particles. These particles are known by what name?
1. Cordite
 2. Ferrite
 3. Pearlite
 4. Austenite
- 6-15. In the heat-treatment process of steel, the element that normally has the greatest influence is carbon.
1. True
 2. False
- 6-16. What color is steel at 1,825°F?
1. Lemon
 2. Salmon
 3. Orange
 4. Light lemon
- 6-17. When water is used as a quenching medium for steel, the water bath should be held at what prescribed temperature?
1. 32°F
 2. 48°F
 3. 55°F
 4. 65°F
- 6-18. When steel is heated above its critical temperature and then slowly cooled, what is the final product called?
1. Sorbite
 2. Pearlite
 3. Troostite
 4. Martensite
- 6-19. After welding a ferrous metal, you should use the normalizing process of heat treatment for what reason?
1. To reduce its carbon content
 2. To induce internal stresses
 3. To remove all strains
 4. To make it harder
- 6-20. Which of the following carburizing methods produces only a thin case?
1. Pack
 2. Gaseous
 3. Nitriding
 4. Cyaniding
- 6-21. What prescribed temperature is required for nitriding steel parts?
1. 950°F
 2. 1,150°F
 3. 1,300°F
 4. 1,400°F
- 6-22. Aluminum alloys are heated by which of the following methods?
1. An air furnace
 2. A molten salt bath only
 3. An electric furnace only
 4. A molten salt bath or an electric furnace
- 6-23. When a nonferrous part is quenched, what is the maximum recommended time between the part's removal from the heat and immersion?
1. 10 sec
 2. 15 sec
 3. 20 sec
 4. 25 sec
- 6-24. When annealing an aluminum part in a salt bath, you should use equal parts of which of the following chemicals?
1. Epsom salt and sodium nitrate
 2. Epsom salt and silver nitrate
 3. Potassium nitrate and baking soda
 4. Potassium nitrate and sodium nitrate
- 6-25. Which of the following metals is used to make aircraft wheel assemblies?
1. Steel
 2. Magnesium
 3. Titanium
 4. Manganese

- 6-26. The flange of a demountable flange wheel is held in place by what component?
1. Locknut
 2. Locking pin
 3. Lockring
 4. Locking key
- 6-27. Which of the following components have been installed on the aircraft wheels to allow the attachment of braking components?
1. The drive keys
 2. The bearing cups
 3. The fusible plug
 4. The demountable flange lock
- 6-28. Which of the following conditions is a major cause for rejection or failure of aircraft wheels?
1. Crashes
 2. Blowouts
 3. Normal wear
 4. Loss of lubrication
- 6-29. Aircraft bearings should be cleaned with what type of solvent?
1. Fuel
 2. Freon
 3. P-D-680
 4. Naphtha
- 6-30. What tool is used to remove the valve core and deflate an installed wheel assembly prior to any maintenance being performed?
1. Needle nose pliers
 2. Safe-Core valve tool
 3. Scribe
 4. 3/8 in. socket
- IN ANSWERING QUESTION 6-31, REFER TO FIGURE 7-5 IN THE TEXT.
- 6-31. What is the minimum length of the stem of a deflated tire tag that is inserted into the valve stem of the wheel assembly?
1. 3/4 inch
 2. 1/2 inch
 3. 1/8 inch
 4. 5/8 inch
- 6-32. What size magnifier is used to perform a visual inspection of bearings, bearing retainers, and bearing cups?
1. 12X
 2. 8X
 3. 5X
 4. 10X
- 6-33. Information on cleaning aircraft wheels can be found in which of the following publications?
1. NAVAIR 01-1A-1
 2. NAVAIR 04-10-1
 3. NAVAIR 04-10-506
 4. NAVAIR 04-10-508
- 6-34. What is the maximum depression allowable in the eutectic material at the threaded end of a fuse plug?
1. 1/32 inch
 2. 1/8 inch
 3. 1/4 inch
 4. 1/16 inch
- 6-35. Which of the following publications will give detailed information on wheel bearing maintenance?
1. NAVAIR 01-1A-8
 2. NAVAIR 04-10-1
 3. NAVAIR 01-1A-503
 4. NAVAIR 04-1-506
- 6-36. A defect in a wheel rim is NOT considered significant unless it is deeper than what prescribed depth?
1. 0.010 in.
 2. 0.015 in.
 3. 0.017 in.
 4. 0.020 in.
- 6-37. The layer of rubber on the outer surface of the tire that protects the cord body from abrasions, cuts, bruises, and moisture is known by what term?
1. Sidewall
 2. Tread
 3. Chafer strips
 4. Undertread

- 6-38. An outer layer of rubber adjoining the tread and extending to the bead is know by what term?
1. Cord body
 2. Tread
 3. Sidewall
 4. Plies
- 6-39. Multiple layers of nylon with individual cords arranged parallel to each other is know by what term?
1. Cord body
 2. Plies
 3. Bead
 4. Undertread
- 6-40. Which of the following tread patterns or designs is NOT used on naval aircraft?
1. Plain
 2. Ribbed
 3. Twisted
 4. Nonskid
- 6-41. Each rebuilt tire receives a final nondestructive inspection by the use of what method?
1. Visual
 2. Electromagnetic
 3. Penetrating radiation
 4. Laser beam optical holographic
- IN ANSWERING QUESTIONS 6-42 THROUGH 6-44, REFER TO FIGURE 7-14.
- 6-42. What total number of times has this tire been rebuilt?
1. One
 2. Two
 3. Four
 4. Five
- 6-43. What is the outside diameter of the tire shown?
1. 14.5 in.
 2. 11.5 in.
 3. 30 in.
 4. 26 in.
- 6-44. What is the ply rating of the tire shown?
1. 26
 2. 38
 3. 45
 4. 43
- 6-45. What color dots mark vent holes on tubeless tires?
1. Red
 2. Green
 3. White
 4. Orange
- 6-46. A tire and wheel assembly should be removed from an aircraft and sent to AIMD if it shows a repeated pressure loss exceeding what prescribed percent of the correct operating inflation pressure?
1. 5 %
 2. 10 %
 3. 2 %
 4. 15 %
- 6-47. What is the dimension of the red slippage mark painted on a tube tire that operates with less than 150 psi?
1. 1/2 inch wide and 2 inches long
 2. 1 inch wide and 1 1/2 inches long
 3. 1 inch wide and 2 inches long
 4. 2 inches wide and 2 inches long
- 6-48. The slippage marks on an aircraft tire should be inspected for slippage on the rim at what maximum interval?
1. Once a week
 2. Once a month
 3. After 10 flights
 4. After every flight
- 6-49. What is the maximum allowable tread wear for tires without wear depth indicators?
1. When 3 layers of cord are exposed at any one spot
 2. When there is 1/16 inch of tread left
 3. When the tire is worn completely smooth
 4. When the tread pattern is worn to the bottom of the tread groove at any one spot
- 6-50. Before disassembling a wheel assembly, what is the first thing you should do?
1. Break the tire bead
 2. Remove the wheel flange
 3. Check the tire for cuts
 4. Ensure the tire is completely deflated

- 6-51. Which of the following tire bead-breaking machines is intended for use at shore-based facilities?
1. Lee-I
 2. Lee-II
 3. Lee-IX
 4. Lee-X
- 6-52. The inner tube of a tube-type aircraft tire may be reused if it is in good condition and less than what total number of years old?
1. 5
 2. 6
 3. 7
 4. 8
- 6-53. Before inserting an inner tube into a tire, you should sprinkle it with which of the following substances?
1. Flour
 2. Water
 3. Cornstarch
 4. Talcum powder
- 6-54. What procedure should you use to identify a tubeless tire?
1. Check the inside of the tire for an orange mark
 2. Check to make sure the word "tubeless" is stamped on the sidewall
 3. Check to make sure the manufacture's mold number is preceded with the letter X
 4. Check the tire's serial number with the list of tubeless tire serial numbers
- 6-55. The remote tire inflator assembly should be calibrated upon initial receipt, before being placed into service, and at what other maximum interval?
1. Every month
 2. Every 2 months
 3. Every 3 months
 4. Every 6 months
- 6-56. You have inflated a tube-type tire to its maximum operating pressure. The tire must remain at this pressure for what minimum length of time before you check it for a pressure loss?
1. 10 min
 2. 5 min
 3. 15 min
 4. 20 min
- 6-57. What solution should you use to clean oil or grease from a tire?
1. P-D-680
 2. Jet fuel
 3. Kerosene
 4. Soap and water
- 6-58. During tire inflation, the setting on the pressure regulator should NEVER exceed what pressure?
1. 800 psi
 2. 700 psi
 3. 600 psi
 4. 500 psi
- 6-59. How long is the service hose on the remote inflator assembly?
1. 8 ft
 2. 10 ft
 3. 15 ft
 4. 20 ft
- 6-60. How high above the maximum required pressure should the remote inflator assembly relief valve be set?
1. 10 %
 2. 20 %
 3. 10 psi
 4. 20 psi
- 6-61. How are tire valve cores designed for aircraft uses identified?
1. "H" on the head of the valve core
 2. Slot in the head of the valve core
 3. Valve core is blue in color
 4. "A" on the head of the valve core
- 6-62. Aircraft tires are inflated to what pressure for storage?
1. 50 percent of operating pressure
 2. 100 psi
 3. Operating pressure or 100 psi, whichever is less
 4. 50 percent of operating pressure or 100 psi, whichever is less
- 6-63. What condition code is put on tires that are potentially rebuildable?
1. "H" (BCM-9)
 2. "F" (BCM-9)
 3. "F" (BCM-1)
 4. "H" (BCM-1)

6-64. Rapid and uneven wear at the outer edges of a tire is an indication of what problem?

1. Underinflation
2. Overinflation
3. Misalignment
4. Out-of-balance

6-65. Rapid wear of the center of the tread of a tire is an indication of what problem?

1. Underinflation
2. Overinflation
3. Misalignment
4. Out-of-balance

IN ANSWERING QUESTION 6-66, REFER TO TABLE 7-1 IN THE TEXT.

6-66. On a dual-wheel installation where the tire has an outside diameter of 35 inches, what is the maximum difference allowed in the outside diameter of the tires?

1. 5/16 in.
2. 3/8 in.
3. 7/16 in.
4. 9/16 in.

6-67. What type of aircraft tubes have radial vent ridges molded on the surface?

1. Type III only
2. Type VII only
3. Type III and type VII
4. Type IV and VII

6-68. Aircraft tubes being stored, should be marked with what information?

1. Size and type only
2. Size, type, and stock number only
3. Size, type, cure date, and stock number
4. Size, type, cure date, and aircraft model

6-69. Which of the following discrepancies would NOT classify an inner tube nonrepairable?

1. A replaceable leaking valve core
2. A cut that completely penetrates the tube
3. A valve stem that is pulled out of the fabric base
4. Severe surface cracking

ASSIGNMENT 7

Textbook Assignment: "Basic Hydraulics," chapter 8, pages 8-1 through 8-33. "Fluid Servicing and Support Equipment," chapter 9, pages 9-1 through 9-9.

- 7-1. What is the principal hydraulic fluid used in military aircraft?
1. MIL-H-46170
 2. MIL-H-81019
 3. MIL-H-83282
 4. MIL-H-5606
- 7-2. Which of the following types of hydraulic fluids is used in extremely low temperatures?
1. MIL-H-46170
 2. MIL-H-81019
 3. MIL-H-83282
 4. MIL-H-5606
- 7-3. Which of the following types of hydraulic fluids is used primarily for preservation?
1. MIL-H-46170
 2. MIL-H-81019
 3. MIL-H-83282
 4. MIL-H-5606
- 7-4. What is the maximum acceptable Navy Standard Class hydraulic fluid particulate level for (a) naval aircraft and (b) support equipment?
1. (a) 3 (b) 3
 2. (a) 3 (b) 5
 3. (a) 5 (b) 3
 4. (a) 5 (b) 5
- 7-5. Hydraulic system fluid analysis is NOT required in which of the following situations?
1. When a pump fails
 2. When extensive maintenance has occurred
 3. When the system is subjected to excessive heat
 4. When the aircraft has flown two flights in less than 12 hours
- 7-6. When hydraulic system fluid is lost to the point that the hydraulic pump runs dry or cavitates, you should take what action?
1. Change the defective pump and flush the system
 2. Change the defective pump and filter elements, and purge the system
 3. Change the defective pump, check the filter elements, and decontaminate as required
 4. Change the defective pump, change all filter elements, and decontaminate as required
- 7-7. Which of the following lubricants is NOT approved for O-ring seals?
1. MIL-G-81322
 2. VV-L-800
 3. MIL-H-46170
 4. MIL-H-83282
- 7-8. Organic contamination is produced by all EXCEPT which of the following processes?
1. Glass bead peening
 2. Polymerization
 3. Oxidation
 4. Wear
- 7-9. Most of the metallic solid contamination is caused by which of the following hydraulic components?
1. Hoses
 2. Pumps
 3. Actuators
 4. Reservoirs
- 7-10. The inorganic solid hydraulic system contamination group includes which of the following contaminants?
1. Dust only
 2. Silicates only
 3. Paint particles only
 4. Dust, silicates, and paint particles

- 7-11. A spongy response during hydraulic system operation would normally be caused by what type of contamination?
1. Air
 2. Water
 3. Inorganic
 4. Particulate
- 7-12. Chlorinated solvents will hydrolyze to form hydrochloric acids when allowed to combine with minute amounts of which of the following substances?
1. Oil
 2. Fuel
 3. Water
 4. Oxygen
- 7-13. A hydraulic oil cooler leak would cause which of the following types of contamination?
1. Air
 2. Particulate
 3. Foreign fluid
 4. Nonmetallic solid
- 7-14. Before you sample support equipment hydraulic systems, the fluid must be recirculated at full flow rate a minimum of how many minutes?
1. 5 min
 2. 10 min
 3. 15 min
 4. 20 min
- 7-15. Aircraft filter assemblies are sampled by removing the filter bowl and transferring what fluid contents to a clean sample bottle?
1. Filter bowl only
 2. Filter element only
 3. Filter element or filter bowl
 4. Filter element and filter bowl
- 7-16. When processing a hydraulic fluid sample, you must use what type of filter?
1. Single 20-mm test filter
 2. Single 47-mm test filter
 3. Double 20-mm test filter
 4. double 47-mm test filter
- 7-17. You are processing a fluid sample and you have poured the hydraulic fluid from the graduate into the funnel. What total amount of solvent should you pour into the graduate?
1. 15 ml
 2. 50 ml
 3. 100 ml
 4. 120 ml
- 7-18. If the hydraulic test filter displays a rust color, what color contamination standards should you use for comparison?
1. Tan
 2. Rust
 3. Gray
 4. Silica
- 7-19. An electronic particle count analysis of hydraulic fluid will NOT be affected by particles smaller than what size?
1. 5 microns
 2. 15 microns
 3. 25 microns
 4. 35 microns
- 7-20. The halogen leak detector is powered by what source of energy?
1. Solar
 2. Battery
 3. 110 volts AC
 4. 220 volts AC
- 7-21. You should perform a hydraulic fluid patch test from what system component to determine when system flushing is complete?
1. System reservoir fluid
 2. System return line fluid
 3. System pressure line fluid
 4. Test stand reservoir fluid
- 7-22. Test stands used for hydraulic system flushing must have an internal reservoir that holds what minimum number of gallons of hydraulic fluid?
1. 10 gal.
 2. 14 gal.
 3. 16 gal.
 4. 20 gal.

- 7-23. Which of the following authorities is required to recommend and supervisor and aircraft hydraulic system purging?
1. The commanding officer
 2. The maintenance officer
 3. The functional wing commander
 4. The cognizant engineering activity
- 7-24. When a hydraulic system is purified, the fluid going to the purification tower is first filtered by what size filter?
1. 25 micron
 2. 15 micron
 3. 5 micron
 4. 3 micron
- 7-25. What is the purpose of the contamination control sequence chart?
1. Guide for decontaminating naval aircraft only
 2. Guide for decontaminating naval aircraft and support equipment
 3. Guide for performing hydraulic fluid patch tests
 4. Guide for managing the contamination control program
- 7-26. The purpose of quick-disconnect couplings is to provide a means of quickly disconnecting a line without having to contend with which of the following problems?
1. System pressure surges
 2. Loss of hydraulic fluid only
 3. Entrance of air into the system only
 4. Loss of hydraulic fluid or entrance of air into the system
- 7-27. What half of a series 145 or series 155 (Aeroquip) coupling has mounting flanges used for attaching them to a bulkhead or other structural member of the aircraft?
1. S1
 2. S2
 3. S3
 4. S4
- 7-28. The protruding nose of the series 145 and 155 (Aeroquip) coupling S4 half engages with what component to provide a positive seal?
1. Sleeve
 2. O-ring
 3. Poppet valve
 4. Tubular valve
- 7-29. Which, if any, of the following types of quick-disconnect couplings allows the use of a wrench to assist in tightening the coupler?
1. Series 3200 quick-disconnects
 2. All series 145 and 155 quick-disconnects
 3. Modified series 145 and 155 quick-disconnects only
 4. None of the above
- 7-30. The hydraulic seal used between non-moving fittings and bosses are known by which of the following terms?
1. Gaskets
 2. O-rings
 3. Packings
 4. Backup rings
- 7-31. What O-rings are replacing the AN6227 and AN230 O-rings?
1. AN6290 O-rings
 2. MS28775 O-rings
 3. MS28777 O-rings
 4. MS28778 O-rings
- 7-32. What O-rings are replacing the AN6290 O-ring?
1. MS28775
 2. MS28920
 3. MS28695
 4. MS28778
- 7-33. What should you do with O-rings that have colored markings, such as dots, dashes, and stripes?
1. Do not use them and purge them from the supply system
 2. Continue to use them until supply is exhausted
 3. Use them only in systems operating below 1500 psi
 4. Use them only in an emergency when no other O-ring is available
- 7-34. O-ring age is computed by what means?
1. From the cure date
 2. From the service life
 3. From the replacement schedule
 4. From the operational conditions

- 7-35. Which of the following materials should NOT be used to fabricate tools for use in replacing and installing O-rings and backup rings?
1. Wood
 2. Steel
 3. Brass
 4. Phenolic rod
- 7-36. What method should you use to inspect the inner diameter of an O-ring for cracks?
1. Perform NDI
 2. Use a small mirror
 3. Roll it onto an inspection cone or dowel
 4. Stretch it between two fingers and visually examine it
- 7-37. When an O-ring installation requires spanning or inserting through sharp threaded areas, ridges, slots, and edges, which of the following devices or procedures should you use?
1. O-ring expanders
 2. O-ring entering sleeves
 3. A rolling motion of the O-ring
 4. Light coating of the threads with MIL-S-8802
- 7-38. What are the two types of backup rings used in naval aircraft?
1. Teflon® single and double spiral
 2. Leather and polyvinyl
 3. O-ring and V-ring
 4. Flat and parallel
- 7-39. What is the specific shelf life, if any, of Teflon® backup rings?
1. 1 year
 2. 2 years
 3. 3 years
 4. They have no shelf life
- 7-40. Teflon® backup rings are identified by which of the following means?
1. Color coding
 2. Coded symbols
 3. Package labels
 4. Visual appearance
- 7-41. When you install Teflon® spiral rings in an internal groove, you must use what type of spiral?
1. Right-hand
 2. Left-hand
 3. Double clockwise
 4. Double counterclockwise
- 7-42. A metallic wiper is installed in what position?
1. The lip facing inward
 2. The lip facing outward
 3. The groove facing inward
 4. The groove facing outward
- 7-43. Which of the following protective closures are approved for sealing hydraulic equipment?
1. Rubber caps and plugs
 2. Metal caps and plugs
 3. Plastic caps and plugs
 4. Paper caps and plugs
- 7-44. What is the fluid holding capacity of a Model H-250-1 servicing unit?
1. 1 gallon
 2. 2 gallons
 3. 3 gallons
 4. 5 gallons
- 7-45. What component of the H-250-1 servicing unit minimizes airborne particulates and moisture contamination?
1. 3 micron filter
 2. 5 micron filter
 3. Check valve
 4. Hand pump restrictor
- 7-46. The H-250-1 hydraulic servicing unit is equipped with what size service hose?
1. 5 ft
 2. 6 ft
 3. 7 ft
 4. 8 ft
- 7-47. Other than filtration, what other function does the 3-micron, in-line filter on the service hose of a H-250-1 unit perform?
1. Air bleeding
 2. Prevents reverse flow
 3. Two way check valve
 4. Restrictor valve
- 7-48. What is the maximum fluid holding capacity of the HSU-1 fluid servicing unit?
1. 1 gallon
 2. 2 gallons
 3. 3 gallons
 4. 4 gallons

- 7-49. The integral reservoir on the HSU-1 servicing unit is constructed from what type of material?
1. Cast aluminum
 2. Iron
 3. Stainless steel
 4. Composite graphite
- 7-50. The sight gauge on the HSU-1 servicing unit reads from zero to how many gallons?
1. 1 gallon
 2. 2 gallons
 3. 3 gallons
 4. 5 gallons
- 7-51. A vent hose is connected on the HSU-1 servicing unit from the top of the reservoir and what other location?
1. Bottom of the reservoir
 2. Vent check valve
 3. Base of the unit
 4. Upper can piercer
- 7-52. What type of pump is on the HSU-1 servicing unit?
1. Single-action, piston air pump
 2. Single-action, piston hand pump
 3. Double-action, piston air pump
 4. Double-action, piston hand pump
- 7-53. With every full stroke of the pump, the HSU-1 will deliver what quantity of fluid?
1. 1.5 fluid ounces
 2. 2.0 fluid ounces
 3. 3.0 fluid ounces
 4. 4.0 fluid ounces
- 7-54. What type of filter is incorporated in the HSU-1 servicing unit?
1. 3-micron, cleanable filter
 2. 3-micron (absolute) cleanable filter
 3. 3-micron (absolute) disposable filter
 4. 3-micron, disposable filter
- 7-55. Where is the filter located on the HSU-1 servicing unit?
1. Inside the reservoir
 2. Above the top piercing unit
 3. Below the lower piercing unit
 4. At the pump base
- 7-56. What is the length of the service hose on a HSU-1 servicing unit?
1. 5 ft
 2. 7 ft
 3. 8 ft
 4. 10 ft
- 7-57. What size fluid container does the Model 310 fluid servicing unit incorporate?
1. 3 gallons
 2. 5 gallons
 3. 8 gallons
 4. 10 gallons
- 7-58. The Model 310 fluid servicing unit uses what type of pump?
1. Single-action hand pump
 2. Double-action hand pump
 3. Constant-displacement, motor-driven pump
 4. Variable-displacement, motor-driven pump
- 7-59. What component of the Model 310 fluid servicing unit prevents the unit from being operated unless there is a filter installed?
1. Air vent valve
 2. Check valve
 3. One-way restrictor valve
 4. Two-way restrictor valve
- 7-60. What component of the Model 310 fluid servicing unit removes free air present in the fluid?
1. Air trap
 2. Air relief valve
 3. Lower vent valve
 4. Upper vent valve
- 7-61. All hydraulic fluid servicing units must be equipped with what type of filtration?
1. 5 micron
 2. 5 micron (absolute)
 3. 3 micron
 4. 3 micron (absolute)
- 7-62. You have spilled hydraulic fluid on an aircraft after servicing it. It must be cleaned with approved wiping materials and with what other cleaning material?
1. Soap and water
 2. Air
 3. Dry-cleaning solvent
 4. Mineral spirits

- 7-63. Other than providing external hydraulic power to an aircraft, a portable hydraulic test stand also serves as the primary means of aircraft decontamination.
1. True
 2. False
- 7-64. What company manufactures the portable Hydraulic Test Stand A/M27T-5?
1. Teledyne Sprague Engineering
 2. General Dynamics, Inc.
 3. Janke and Company, Inc.
 4. Dynacorp, Inc.
- 7-65. The A/M27T-5 portable hydraulic test stand is replacing what other test stand?
1. A/M27T-3
 2. A/M27T-7
 3. AHT-63
 4. AHT-64
- 7-66. At what psi does the A/M27T-5 provide a flow rate of 24 gpm?
1. 1,000 psi
 2. 2,000 psi
 3. 3,000 psi
 4. 4,000 psi
- 7-67. The fluid temperature warning light on the A/M27T-5 unit will illuminate at what temperature?
1. 120°F
 2. 160°F
 3. 180°F
 4. 200°F
- 7-68. How many gpm does the pressure outlet flowmeter on the A/M27T-5 unit indicate?
1. 2 to 10 gpm
 2. 2 to 15 gpm
 3. 2 to 30 gpm
 4. 2 to 50 gpm
- 7-69. On the A/M27T-5, the S2 switch will close when the pressure between the high pressure filter inlet and outlet port is different by how much psi?
1. 25 psi
 2. 50 psi
 3. 75 psi
 4. 100 psi
- 7-70. What is the range of the fluid temperature gauge on the A/M27T-5 unit?
1. 10° to 100°
 2. 20° to 150°
 3. 20° to 175°
 4. 20° to 220°
- 7-71. What is the range of the head temperature gauge on the A/M27T-5 unit?
1. 50° to 100°
 2. 100° to 250°
 3. 250° to 350°
 4. 350° to 500°
- 7-72. What publication covers detailed information on the A/M27T-5?
1. NA 17-15BF-89
 2. NA 17-15BF-91
 3. NA 17-15BF-93
 4. NA 17-15BF-95
- 7-73. What is the type equipment code (TEC) for the A/M27T-5 unit?
1. GJCA
 2. GGJZ
 3. GGJV
 4. GCAA
- 7-74. What is the type equipment code (TEC) for the A/M27T-7 unit?
1. GJCA
 2. GGJZ
 3. GGJV
 4. GCAA
- 7-75. If the manifold of a portable test stand is equipped with a shutoff valve, what position must the valve be in prior to starting the unit?
1. Open
 2. Close
 3. Off
 4. Normal

ASSIGNMENT 8

Textbook Assignment: "Fluid Servicing and Support Equipment," chapter 9, pages 9-9 through 9-21. "Hose and Tubing Fabrication and Maintenance," chapter 10, pages 10-1 through 10-49.

- 8-1. Portable hydraulic test stands must be allowed to recirculation clean for how long prior to using the unit?
1. 1 to 2 minutes
 2. 3 to 5 minutes
 3. 5 to 7 minutes
 4. 8 to 10 minutes
- 8-2. What is the normal fluid operating temperature on a portable hydraulic test stand?
1. 75°
 2. 85°
 3. 95°
 4. 100°
- 8-3. What is the recommended minimum inside bend radius for a 1/2-inch test stand hose?
1. 5.90
 2. 5.37
 3. 4.30
 4. 2.30
- 8-4. What is the recommended minimum inside bend radius for a 1-inch test stand hose?
1. 7.31
 2. 5.90
 3. 5.37
 4. 4.30
- 8-5. When operating a portable hydraulic test stand on an aircraft system, you should use the test stand reservoir mode whenever possible for what reason?
1. This mode ensures positive flow to the aircraft pump
 2. This mode eliminates the possibility of aircraft pump cavitation
 3. This mode enables aircraft fluid deaeration during system operation
 4. This mode allows the test stand reservoir supply valve to remain open, allowing greater backpressure in the return system
- 8-6. When using a portable hydraulic test stand on an aircraft in test stand mode, you must adjust the backpressure reducing valve to what pressure?
1. Normal system operating pressure
 2. Normal aircraft reservoir pressure
 3. Half the normal system operating pressure
 4. Half the normal aircraft reservoir pressure
- 8-7. When you are using a portable hydraulic test stand during an aircraft operation, the bypass control should be in what position?
1. Half opened
 2. Fully opened
 3. Fully closed
 4. Adjusted to the operating pressure
- 8-8. Other than a loaded filter, what will cause a pressure differential indicator (PDI) on a filter assembly to pop up?
1. Cold weather starting
 2. Hot weather starting
 3. A new filter
 4. Low fluid level
- 8-9. What action must you take if a pressure differential indicator pops up on a portable hydraulic test stand after you have reset the indicator?
1. Reset the indicator again
 2. Remove and replace the filter
 3. Check the fluid level
 4. Turn in the equipment to the supporting activity
- 8-10. During normal operation of a portable hydraulic test stand, an engine part fails. What procedure should you follow?
1. Reduce the pressure slowly
 2. Reduce the pressure rapidly
 3. Turn off electrical power
 4. Stop the engine

- 8-11. During shutdown, before the throttle of an engine-driven portable hydraulic test stand is pushed completely closed, the engine should run at 100 rpm for approximately how many minutes?
1. 1 min
 2. 5 min
 3. 10 min
 4. 12 min
- 8-12. You can accomplish simultaneous multisystem operational checks on an aircraft by using which of the following methods?
1. By attaching a T-fitting between the aircraft system's main selector valve
 2. By using a separate hydraulic test stand for each aircraft system only
 3. By manifolding two or more aircraft systems to a common test stand only
 4. Both 2 and 3 above
- 8-13. The test chamber of the HCT-10 stationary hydraulic test stand is constructed from what material?
1. 1/4-inch steel plate
 2. 1/2-inch steel plate
 3. 1/2-inch aluminum plate
 4. 7/8-inch aluminum plate
- 8-14. Before connecting a portable hydraulic test stand to an aircraft system, what two tasks must you accomplish?
1. Service the reservoir and set parking brake
 2. Set parking brake and apply electrical power
 3. Service reservoir and take a hydraulic sample
 4. Recirculation clean the unit and take a hydraulic sample
- 8-15. Air in a hydraulic system generates no problem as long as it remains in what state?
1. Free
 2. Filtered
 3. Dissolved
 4. Entrained
- 8-16. When free air enters a fluid at a very high rate, the rapid collapse of bubbles generates extremely high local fluid velocities that are converted into impact pressure. What is this phenomenon known as?
1. Starvation
 2. Cavitation
 3. Modulation
 4. Consumption
- 8-17. To aid in the removal of free air, what components are sometimes provided at high points in the aircraft hydraulic circulatory system?
1. Check valves
 2. Filler valves
 3. Restrictor valves
 4. Air bleed valves
- 8-18. What must be accomplished after you have completed all air bleed operations?
1. Turn in the unit for further maintenance
 2. Disconnect and reconnect the unit to the aircraft
 3. Check the hydraulic fluid levels
 4. Shut down the unit and re-start it
- 8-19. Age-controlled, deteriorative-type hoses used to carry hydraulic fluid in SE units should NOT remain in service for more than what maximum number of years beyond the manufacturer's cure date?
1. 5 years
 2. 6 years
 3. 7 years
 4. 8 years
- 8-20. Prior to hydraulic sampling, SE must be run for what maximum length of time?
1. 5 min
 2. 7 min
 3. 10 min
 4. 15 min
- 8-21. What is the part number for the hydraulic fluid contamination analysis kit?
1. P/N 571114
 2. P/N 571414
 3. P/N 574411
 4. P/N 574141

- 8-22. When SE is found to be unacceptably contaminated with particulate matter, but the fluid is otherwise considered satisfactory, you should use which of the following decontamination methods?
1. Purging
 2. Flushing
 3. Purifying
 4. Recirculation cleaning
- 8-23. When the hydraulic fluid of SE contains a substance not readily removed by the internal filters, what decontamination method should you use?
1. Purging
 2. Flushing
 3. Purifying
 4. Recirculation cleaning
- 8-24. What decontamination method must be performed under the direct supervision of the cognizant engineering activity?
1. Purging
 2. Flushing
 3. Purifying
 4. Recirculation cleaning
- 8-25. How many basic types of hoses are used in military aircraft?
1. One
 2. Two
 3. Three
 4. Four
- 8-26. How is a wire-braid Teflon hose assembly identified?
1. A band at one end
 2. A band at both ends
 3. A band in the middle of the hose
 4. A band at each end and in intervals of every 3 feet
- 8-27. What size is a -8 hose assembly?
1. 1/4 inch
 2. 3/8 inch
 3. 8/16 inch
 4. 1/2 inch
- 8-28. Aircraft hose fittings are manufactured from aluminum, carbon steel, and what other material?
1. Iron
 2. Brass
 3. Titanium alloy
 4. Corrosion-resistant steel
- 8-29. What are the two methods used to secure a hose fitting on a hose?
1. Flared and flareless
 2. Reusable and crimp
 3. Flared and crimp
 4. Flareless and reusable
- 8-30. What style of fittings is authorized as replacement fittings for replacement hose assemblies?
1. Swage style
 2. Crimp style
 3. Flared style
 4. Reusable style
- 8-31. What type of fitting requires the socket to be permanently deformed by an electric or hydraulic-powered machine?
1. Crimp
 2. Reusable
 3. Flared
 4. Flareless
- 8-32. What part of a hose fitting fits the inside diameter of a hose?
1. Socket
 2. Flange
 3. Nipple
 4. Sleeve
- 8-33. What color is a steel flared hose fitting?
1. Blue
 2. Brown
 3. Black
 4. Cadmium
- 8-34. Which of the following identification band codes identifies a hose assembly that was manufactured in June 1980?
1. A2Q80
 2. A3Q80
 3. 2Q1980
 4. 6Q1980
- 8-35. Where should an identification tag be placed on a locally manufactured hose assembly?
1. In the middle of the hose
 2. 1/4 inch from the end
 3. Directly following the end fitting
 4. Not less than 1/2 inch from the end fitting

- 8-36. Fabrication of hoses is the function of what maintenance level?
1. Organizational
 2. Intermediate
 3. Depot
 4. Intermediate and Depot
- 8-37. When failure of a flexible hose assembly with swaged end fittings occurs, what procedure should you follow?
1. Replace the fitting
 2. Splice the damaged section
 3. Retorque the fittings
 4. Remove and replace the entire assembly
- 8-38. What manual contains information on the fabrication of a hose assembly?
1. NA 01-1A-17
 2. NA 01-1A-20
 3. NA 01-1A-22
 4. NA 01-1A-23
- 8-39. Oxygen hose assemblies must be cleaned and tested in accordance with what manual?
1. NA 01-1A-17
 2. NA 01-1A-20
 3. NA 13-1-6-4
 4. NA 13-1-4-4
- 8-40. What other test media can be used to proof pressure test a hydraulic hose assembly other than MIL-H-6083 and MIL-H-46170, Type II?
1. Water
 2. Nitrogen
 3. Clean, dry air
 4. Lubricating oil
- 8-41. The Greer aircraft hydraulic hose test stand is capable of developing static pressure up to what psi?
1. 3,000 psi
 2. 30,000 psi
 3. 40,000 psi
 4. 50,000 psi
- 8-42. What is the first step in proof testing a hose assembly using the Greer test stand?
1. Connect air supply to the stand
 2. Pressure regulator to the low setting
 3. Pressure regulator to the off setting
 4. Make sure the reservoir is full
- 8-43. What is the maximum hydraulic pressure available on the CGS Scientific hose burst test stand?
1. 3,000 psi
 2. 5,000 psi
 3. 10,000 psi
 4. 15,000 psi
- 8-44. What is the maximum pneumatic pressure available on the CGS Scientific hose burst test stand?
1. 1,000 psi
 2. 1,500 psi
 3. 3,000 psi
 4. 5,000 psi
- 8-45. If a leak on a swivel nut of a hose assembly is still present after you have retorqued it, what procedure should you follow?
1. Retorque it once again
 2. Remove fitting, clean, and reinstall
 3. Replace the swivel fitting
 4. Replace the entire hose assembly
- 8-46. What is the first step in the removal of a hydraulic hose assembly from an aircraft?
1. Remove all supporting clamps
 2. Remove any lockwire
 3. Perform contamination control procedures
 4. Turn swivel nuts to remove the hose assembly
- 8-47. What is the maximum torque applied to the end fittings of a -8 hose assembly with aluminum fittings?
1. 230 inch-pounds
 2. 260 inch-pounds
 3. 430 inch-pounds
 4. 470 inch-pounds
- 8-48. What period of time applies to a hose from its cure date to the procuring activity's date of acceptance?
1. Age control
 2. Acceptance life
 3. Shelf life
 4. Service life
- 8-49. What type of hose assembly is replaced on a conditional basis?
1. Teflonâ hose
 2. Synthetic rubber hose
 3. Steel braided hose
 4. Carbon Steel braided hose

- 8-50. What is the outside diameter of a No. 6 tubing assembly?
1. 1/8 inch
 2. 1/4 inch
 3. 3/8 inch
 4. 5/16 inch
- 8-51. The wall thickness of a tube assembly is specified in what measurement?
1. Tenths of an inch
 2. Hundredths of an inch
 3. Thousandths of an inch
 4. Ten thousandth of an inch
- 8-52. Tubing assemblies used in landing gear, wing flap, and brake systems are manufactured from what type of tubing?
1. Corrosion-resistant steel
 2. Aluminum alloy
 3. Titanium alloy
 4. Stainless steel
- 8-53. What type of aluminum alloy tubing can be used to replace any aluminum line?
1. 2024 T3
 2. 2024 T6
 3. 5056 T6
 4. 6061 T6
- 8-54. What color is an aluminum alloy tube fitting?
1. Blue
 2. Black
 3. Brown
 4. Cadmium
- 8-55. How many different types of tube cutters can be used to cut a piece of tubing?
1. One
 2. Two
 3. Three
 4. Four
- 8-56. If a tube cutter is not available, what other method can be used to cut a piece of tubing?
1. Coping saw
 2. Band saw
 3. Jig saw
 4. Fine-tooth hacksaw
- 8-57. The chamfer left on the end of a tube after it has been deburred should not exceed what measurement?
1. 1/4 wall thickness
 2. 1/3 wall thickness
 3. 1/8 wall thickness
 4. 1/2 wall thickness
- 8-58. What is the smallest size of aluminum tubing that you can bend by hand to form a radius?
1. 1/8 inch
 2. 1/16 inch
 3. 1/4 inch
 4. 3/8 inch
- 8-59. The number of degrees marked on a hand tube bender are from 0 to what degree?
1. 45 degrees
 2. 60 degrees
 3. 90 degrees
 4. 180 degrees
- 8-60. How many different types of flared tubing joints are used to manufacture aircraft tubing assemblies?
1. Two
 2. Three
 3. Four
 4. Five
- 8-61. The double-flared joint is used on 5052 aluminum alloy tubing with an outside diameter that is less than what measurement?
1. 1/8 inch
 2. 1/4 inch
 3. 3/8 inch
 4. 1/2 inch
- 8-62. How many times can a steel connector be used as a presetting tool on a piece of aluminum tubing?
1. One time
 2. Two times
 3. Four times
 4. Five times
- 8-63. What is the maximum lengthwise movement a sleeve can have on the fittings of a tube assembly?
1. 1/64 inch
 2. 1/32 inch
 3. 1/16 inch
 4. 1/8 inch

- 8-64. Tube assemblies that will be installed in a system with an operating pressure of less than 50 psi must be proof tested at what minimum pressure?
1. 50 psi
 2. 75 psi
 3. 100 psi
 4. 200 psi
- 8-65. What manual contains information on the type of protective finishes that must be applied to aircraft tubing assemblies?
1. NA 01-1A-1
 2. NA 01-1A-20
 3. NA 01-1A-22
 4. NA 01-1A-509
- 8-66. What method is used to identify a tube assembly where identification tape cannot be installed because of the location of the line?
1. Use a scribe
 2. Use an etcher
 3. Use colored markers
 4. Use paint
- 8-67. How many general classes of hazards are associated with fluids that travel through a tubing assembly?
1. 2
 2. 4
 3. 5
 4. 10
- 8-68. An aluminum alloy tube carrying pressure greater than 100 psi must be replaced if it has a scratch or nick greater than what percentage of the tube wall thickness?
1. 5%
 2. 10%
 3. 15%
 4. 20%
- 8-69. How far beyond the normal torque can a steel flared tube assembly be tightened if it is leaking?
1. 1/16 turn
 2. 1/8 turn
 3. 1/4 turn
 4. 1/2 turn
- 8-70. What tool should NOT be used to tighten a tube connector?
1. Combination wrench
 2. Adjustable wrench
 3. Strap wrench
 4. Pliers
- 8-71. How far apart should you install support clamps on a 3/8-inch aluminum alloy tube assembly?
1. 13-1/2 inches
 2. 16-1/2 inches
 3. 26-1/2 inches
 4. 28-1/2 inches
- 8-72. When does a temporary repair of a tube assembly need to be replaced by a permanent repair?
1. During the next daily inspection
 2. During the next special inspection
 3. During the next phase inspection
 4. During the next rework cycle
- 8-73. Engine related tube assemblies are normally manufactured from what material?
1. Corrosion-resistant steel
 2. Titanium alloy
 3. Stainless steel
 4. Aluminum alloy
- 8-74. How many different types of tube failures can you repair by using Permaswage fittings and techniques?
1. 3
 2. 4
 3. 5
 4. 10
- 8-75. How much psi does the D10004 portable hydraulic power supply generate when used for swaging tube fittings?
1. 1,000 psi
 2. 3,000 psi
 3. 3,500 psi
 4. 5,500 psi

ASSIGNMENT 9

Textbook Assignment: "Basic Actuating Systems," chapter 11, pages 11-1 through 11-20. "Basic Hydraulic/Pneumatic and Emergency Power Systems," chapter 12, pages 12-1 through 12-9.

- 9-1. What unit transforms hydraulic fluid pressure into mechanical force, which performs work by moving some mechanism?
1. An actuating unit
 2. A cylinder unit
 3. A control unit
 4. A power unit
- 9-2. Aircraft actuating cylinders are used when which of the following mechanism movements are required?
1. Bilateral motion
 2. Linear motion only
 3. Reciprocating motion only
 4. Linear or reciprocating motion
- 9-3. If hydraulic pressure is used to move a single-acting actuating cylinder in only one direction, all EXCEPT which of the following forces may be used to move it in the opposite direction?
1. Gravity
 2. Fluid bypass
 3. Spring tension
 4. Nitrogen pressure
- 9-4. The operation of a single-acting, spring-loaded, piston-type actuating cylinder is normally controlled by what component?
1. A directional control valve
 2. A limiting switch
 3. A priority valve
 4. A sequence valve
- 9-5. In reference to a double-acting, piston-type actuating cylinder, which of the following statements is correct?
1. There are two pressure and two return ports
 2. The cylinder contains two pistons and one rod
 3. Fluid pressure can be applied to either side of the piston
 4. The stroke of the piston rod travels in one direction only
- 9-6. An unbalanced, double-acting, piston-type actuating cylinder uses a directional control valve capable of directing fluid in what total number of ways?
1. One
 2. Two
 3. Three
 4. Four
- IN ANSWERING QUESTION 9-7, REFER TO FIGURE 11-3.
- 9-7. When the cylinder is in the down and locked position, the locking ball bearings are held in the locking position by what means?
1. Hydraulic pressure
 2. A ball-lock plunger
 3. Detent springs
 4. A piston shaft
- 9-8. To equalize the displacement of fluid on either side of the piston, a double-action, finger-lock actuator incorporates what component?
1. A piston spring
 2. A balance shaft
 3. An inner cylinder
 4. An integral spring-loaded mechanical lock
- 9-9. During normal extension of a landing gear finger-lock actuator, which of the following forces move(s) the piston over the fingers?
1. The airstream only
 2. Hydraulic pressure only
 3. Hydraulic pressure and spring tension only
 4. Hydraulic pressure, spring tension, and the airstream
- 9-10. In a power-operated flight control system, all the force necessary for deflecting the control surface is supplied by hydraulic pressure.
1. True
 2. False

- 9-11. A tandem-type, control surface actuating cylinder uses a synchronizing rod for what purpose?
1. To direct pressure to each control surface
 2. To isolate fluid pressure during an emergency
 3. To equalize the flow of fluid into the actuator piston chambers
 4. To allow the pilot to operate either flight control surface independently
- 9-12. In the maintenance of actuating cylinders, what is the most common trouble encountered?
1. External leakage
 2. Internal leakage
 3. Mechanical damage
 4. Electrical damage
- 9-13. Hydraulic pressure is converted into rotary mechanical motion by which of the following components?
1. A hydraulic motor
 2. An actuating cylinder
 3. A power control cylinder
 4. A control surface actuator
- 9-14. Hydraulic motors are commonly used to operate which of the following aircraft equipment?
1. Rudders and stabilizers
 2. Radar and wing flaps
 3. Speed brakes and trim tabs
 4. Landing and arresting gear
- 9-15. To relieve pressure created by thermal expansion of the fluid, a system that has a balanced poppet-type selector valve must also incorporate what other type of valve?
1. A one-way check valve
 2. A thermal relief valve
 3. A sequence control valve
 4. A manually operated relief valve
- IN ANSWERING QUESTION 9-16, REFER TO FIGURE 11-8.
- 9-16. The poppets of a poppet-type selector valve are actuated by what means?
1. The solenoid
 2. The poppet spring
 3. The return fluid pressure
 4. The cams on the camshaft
- 9-17. When all four of the poppets of a poppet-type selector valve are held firmly seated by the springs and there is no fluid flow, the valve is in what position?
1. The return position
 2. The working position
 3. The neutral position
 4. The pressure position
- 9-18. External leakage from a poppet-type selector valve could be caused by which of the following conditions?
1. A damaged O-ring packing on the poppet
 2. A damaged gasket under the sealing plug
 3. A damaged center packing on the camshaft
 4. A damaged bottom gasket on the poppet seat
- 9-19. Currently, what type of selector valve is the most durable and trouble-free?
1. The slide-type
 2. The poppet-type
 3. The shuttle-type
 4. The solenoid-type
- 9-20. The slide-type selector valve has raised, machined portions that are known by which of the following terms?
1. Stops
 2. Lands
 3. Lobes
 4. Retainers
- 9-21. A slide-type selector valve has three grooves at the end next to the eye. The grooves are known by which of the following terms?
1. Lines
 2. Lands
 3. Rings
 4. Detents
- 9-22. A slide-type selector valve should have a light film of hydraulic fluid applied to the exposed areas of the slide primarily for what purpose?
1. To prevent corrosion
 2. To lubricate the slide
 3. To prevent external leakage
 4. To prevent the entry of foreign matter
- 9-23. A solenoid-operated selector valve is controlled by what means?
1. Electrically
 2. Mechanically
 3. Hydraulically
 4. Pneumatically

- 9-24. A solenoid-operated selector valve directs the flow of fluid to and from the actuator by the use of what component?
1. The plunger
 2. The pilot slide
 3. The selector slide
 4. The lever assembly
- 9-25. For the proper cleaning, inspection, repair, and testing of selector valves, you should use what series of NAVAIR manuals as a guide?
1. 01 series
 2. 02 series
 3. 03 series
 4. 04 series
- 9-26. When testing a solenoid selector valve, you must bleed all air from the valve before applying pressure for which of the following reasons?
1. To prevent premature operation of the solenoids
 2. To ensure proper lubrication of the parts
 3. To ensure proper seating of the O-rings
 4. To prevent a leak from going undetected
- 9-27. The purpose of a check valve is to allow the fluid to flow in one direction only.
1. True
 2. False
- 9-28. A bypass check valve differs from an automatic check valve in which of the following ways?
1. It can be manually closed to completely stop the flow of fluid in both directions
 2. It can be manually opened to allow fluid to flow in both directions
 3. It is automatically opened to allow fluid to flow in both directions
 4. It is automatically opened to allow restricted flow in both directions
- 9-29. Sequence valves may be operated in which of the following ways?
1. By pressure only
 2. By pressure or mechanically only
 3. By pressure, mechanically, or electrically only
 4. By pressure, mechanically, electrically, or pneumatically
- 9-30. What are the two types of mechanically operated sequence valves?
1. Equal and unequal
 2. Loaded and unloaded
 3. Manual and automatic
 4. Balanced and unbalanced
- 9-31. Trouble associated with a mechanically operated sequence valve is most commonly a result of what problem?
1. Foreign matter
 2. Weak valve springs
 3. Faulty O-ring seals
 4. Improper adjustment
- 9-32. Isolation of the normal system from the emergency hydraulic system is the main function of what valve?
1. The shuttle valve
 2. The control valve
 3. The priority valve
 4. The isolation valve
- 9-33. Excessive heating of a shuttle valve is a good indication of what type of problem?
1. Internal leakage
 2. External leakage
 3. Improper adjustment
 4. Broken mechanical linkage
- 9-34. An actuating units speed of operation is controlled by what component?
1. A capacitor
 2. A restrictor
 3. A priority valve
 4. A sequence valve
- 9-35. To retard the action of a hydraulic cylinder by limiting the flow of fluid in both directions, you should use which of the following devices?
1. A timing valve
 2. A control valve
 3. A one-way restrictor
 4. A two-way restrictor
- 9-36. A system that combines the use of hydraulics and pneumatics is known by what term?
1. Hydroponics
 2. Pneumatolytic
 3. Pneumatophore
 4. Hydropneumatics

- 9-37. Hydraulic flight control system design specifications require what total number of separate systems for operation of the primary flight controls?
1. One
 2. Two
 3. Three
 4. Four
- 9-38. In an open-center hydraulic system, what type of valve prevents pressure from building up until a demand is placed on the system?
1. A check valve
 2. A bypass valve
 3. A selector valve
 4. A pressure-relief valve
- 9-39. In an open-center hydraulic system, the selector valve automatically returns to the neutral position and to open-center flow when the actuating mechanism reaches the end of its cycle and the system relief valve setting is reached. This is known as what type of selector valve?
1. Manually engaged and pressure disengaged
 2. Manually engaged and manually disengaged
 3. Pressure engaged and pressure disengaged
 4. Pressure engaged and manually disengaged
- 9-40. A closed-center hydraulic system with a variable displacement pump has what type of valve installed as a backup safety for over pressurization?
1. A check valve
 2. A bypass valve
 3. A relief valve
 4. A selector valve
- 9-41. What type of hydraulic control valves and actuators operate the primary flight controls?
1. Single acting
 2. Double acting
 3. Hydropneumatic
 4. Tandem construction
- IN ANSWERING QUESTIONS 9-42 AND 9-43, REFER TO FIGURE 12-2 IN THE TEXTBOOK.
- 9-42. The reservoir is pressurized by what force?
1. Ram air
 2. Engine bleed air
 3. Hydraulic pressure
 4. Accumulator preload
- 9-43. What valve shuts off flow to the secondary systems during flight?
1. The air valve
 2. The check valve
 3. The snubber valve
 4. The isolation valve
- 9-44. According to military specifications, all hydraulically operated systems considered essential to flight safety or landing must have provisions for emergency actuation.
1. True
 2. False
- 9-45. What component stores the supply of fluid for a hydraulic system?
1. An actuator
 2. A reservoir
 3. A selector valve
 4. A hydraulic motor
- 9-46. A finger strainer is installed in the filler neck of some nonpressurized reservoirs for what purpose?
1. To trap air that enters the system
 2. To clean the fluid as the reservoir is filled
 3. To clean the fluid as it leaves the reservoir
 4. To serve as a reservoir pressure bypass
- 9-47. The instruction plate of a reservoir contains all EXCEPT which of the following information?
1. The specification number and color of the fluid to be used
 2. The complete instructions for filling the reservoir
 3. The frequency the reservoir should be purged
 4. The fluid capacity of the reservoir
- 9-48. There are a total of how many classes of hydraulic reservoirs?
1. One
 2. Two
 3. Three
 4. Four

9-49. The fluid quantity of a nonpressurized reservoir is indicated by a float and arm liquidometer. The liquidometer is operated by what means?

1. Mechanically
2. Electrically
3. Pneumatically
4. Hydraulically

9-50. What is the purpose of a reservoir pressure and vacuum-relief valve?

1. To vent the reservoir to the cabin
2. To maintain 15 psi in the reservoir
3. To allow fluid to flow between the main system reservoirs
4. To maintain a differential pressure range between the reservoir and the cabin

9-51. In an air-pressurized reservoir, the fluid quantity is indicated by what means?

1. The distance the piston rod protrudes from the reservoir end cap
2. The level of fluid shown in the sight gauge
3. The level of fluid in the filter neck
4. The level of fluid on the dip stick

ASSIGNMENT 10

Textbook Assignment: "Basic Hydraulic/Pneumatic and Emergency Power Systems," chapter 12, pages 12-10 through 12-43.

- 10-1. What is the purpose of a chemical air dryer?
1. To prevent air from entering the system
 2. To seal the reservoir at the filler neck
 3. To prevent moisture from escaping from the reservoir
 4. To absorb moisture that may collect from air entering the system
- 10-2. Normally, an air pressure regulator maintains what amount of pressure in the reservoir?
1. 10 psi
 2. 15 psi
 3. 40 psi
 4. 90 psi
- 10-3. An air-relief valve is usually incorporated in the air portion of a hydraulic power system to relieve excessive air pressure that may enter the system from what malfunctioning component?
1. A check valve
 2. A filler valve
 3. A chemical air dryer
 4. An air pressure regulator
- 10-4. To allow pressurized air from the reservoir to flow through the air bleeder valve to an overboard vent, you should take what action?
1. Depress the push button
 2. Release the push button
 3. Turn the hex nut clockwise
 4. Turn the hex nut counterclockwise
- 10-5. A fluid-pressurized reservoir is divided into two chambers by what device?
1. A pressure probe
 2. A vertical baffle
 3. A floating piston
 4. A horizontal diaphragm
- 10-6. For the operation of actuating units in an emergency, what type of pump is generally installed?
1. A motor-driven pump
 2. A double-action pump
 3. An engine-driven pump
 4. A single-action hand pump
- 10-7. What type of hand pumps is used in naval aircraft hydraulic systems?
1. Single-action
 2. Simple-stroke
 3. Double-action
 4. Compound-stroke
- IN ANSWERING QUESTION 10-8, REFER TO FIGURE 12-13 IN THE TEXTBOOK.
- 10-8. What action takes place when the piston in the pump is moved to the right?
1. Check valve A opens; check valve B closes; fluid enters port C
 2. Check valve A closes; check valve B opens; fluid exits port D
 3. Check valve A opens; check valve B closes; fluid exits port D
 4. Check valve A closes; check valve B closes; fluid exits port D
- 10-9. When air is in the emergency hydraulic system and the handle of the hand pump is moved to the right, what handle reaction, if any, will occur?
1. It will creep slowly to the left only
 2. It will creep slowly to the left and then spring rapidly to the right
 3. It will spring rapidly to the left
 4. None
- 10-10. A pump that delivers 3 gallons of fluid per minute at a speed of 2,800 rpm, and continues to deliver at that rate regardless of the pressure in the system, is known as what type of pump?
1. A variable-displacement pump
 2. A constant-displacement pump
 3. A rotary-action pump
 4. A gear-type pump
- 10-11. The use of a variable displacement pump in a hydraulic system eliminates the need for what component?
1. A reservoir
 2. An accumulator
 3. A hydraulic fuse
 4. A pressure regulator

- 10-12. Gear-type pumps are usually driven by what means?
1. A dc electric motor
 2. An ac electric motor
 3. An aircraft engine
 4. A servo unit
- 10-13. A piston-type (constant displacement) pump sucks fluid into one port and forces it out the other port. This is known as what type of piston motion?
1. Axial
 2. Rotary
 3. Reciprocating
 4. Counterrotating
- 10-14. To change the rotation of a piston-type (constant displacement) pump, you must perform which of the following functions?
1. Reverse the drive gears
 2. Reverse the universal link
 3. Rotate the valve plate 90 degrees
 4. Rotate the valve plate 180 degrees
- 10-15. The internal parts of a Stratopower (variable displacement) pump perform what four major functions?
1. Hydraulic drive, flow control, pressure regulation, and bypass
 2. Pressure control, mechanical drive, bypass, and fluid displacement
 3. Bypass, pressure regulation, fluid displacement, and hydraulic drive
 4. Pressure control, flow control, mechanical drive, and pressure regulation
- 10-16. A Stratopower pump has creep plates installed for what purpose?
1. To increase the angle of the drive cam
 2. To decrease wear on the revolving cam
 3. To provide a support for the stationary bearing
 4. To ensure proper alignment of the nutation plate
- 10-17. During operation of a Stratopower pump in a nonflow condition, lubrication is provided by what means?
1. A bypass system
 2. A bypass piston
 3. A compensator piston
 4. A compensator spring
- 10-18. To provide a positive fluid pressure at the suction port, what type of boost pump is incorporated into the Vickers electric, motor-driven, variable-displacement pump?
1. A centrifugal boost pump
 2. A Stratopower boost pump
 3. A ramp-type boost pump
 4. A turbo boost pump
- 10-19. As system pressure drops, the Vickers electric, motor-driven pump will provide what maximum flow rate?
1. 6 gpm at 2,900 psi
 2. 8 gpm at 2,200 psi
 3. 8 gpm at 3,000 psi
 4. 9 gpm at 3,100 psi
- 10-20. During an inspection you find metal slivers on the gearbox magnetic drain plug of a Vickers electric, motor-driven pump. What action should you take?
1. Replace the gearbox
 2. Replace the magnetic plug
 3. Drain and service the pump
 4. Remove the pump for overhaul
- 10-21. Relief valves are installed in aircraft hydraulic systems for what purpose?
1. To aid in control stick movement
 2. To prevent shock strut overpressurization
 3. To protect the system from excessive fluid pressurization
 4. To direct the flow of fluid from the pump to the actuators
- 10-22. To increase the opening pressure of a thermal relief valve, what action must you take?
1. Turn the adjusting screw clockwise
 2. Turn the adjusting screw counterclockwise
 3. Replace the poppet spring and ball with a larger one
 4. Replace the poppet spring and ball with a smaller one
- 10-23. A shutoff valve is used for all EXCEPT which of the following purposes?
1. To control the flow of fluid
 2. To relieve excessive pressure
 3. To control the speed a component moves
 4. To help isolate trouble by shutting off systems or subsystems

- 10-24. An electric solenoid shutoff valve is also referred to as what type of valve?
1. A priority valve
 2. A sequential valve
 3. A compensator valve
 4. An electrocontrol valve
- 10-25. You can stop the flow of fluid in a needle-type, manual shutoff valve by which of the following means?
1. Pulling the lever
 2. Pushing the lever
 3. Turning the handle in a clockwise direction
 4. Turning the handle in a counterclockwise direction
- 10-26. What is the maximum allowable temperature for any type of military aircraft hydraulic system?
1. 100°F
 2. 200°F
 3. 300°F
 4. 400°F
- 10-27. A radiator-type hydraulic fluid cooler uses what medium for cooling?
1. Engine oil
 2. Engine fuel
 3. Ambient air
 4. Electric blower
- 10-28. What component is used to conserve space and provide a means where common fluid lines may come together?
1. A venturi
 2. A network
 3. A manifold
 4. A control center
- 10-29. What three basic units make up a filter assembly?
1. Filter element, bowl, and poppet
 2. Bowl, head assembly, and filter element
 3. Head assembly, bypass valve, and filter element
 4. Differential pressure indicator, bowl, and filter element
- 10-30. What type of noncleanable filter element is used on most naval aircraft?
1. 5-micron (absolute)
 2. 3-micron (absolute)
 3. 3-micron
 4. 5-micron
- 10-31. The differential pressure indicator on a filter assembly is reset by what means once the button is extended?
1. Pneumatically
 2. Hydraulically
 3. Electrically
 4. Manually
- 10-32. To prevent fluid loss when the bowl has been removed, most filter assemblies incorporate what item in the head?
1. A check valve
 2. A cover plate
 3. A quick-disconnect
 4. An automatic shutoff valve
- 10-33. Prior to the installation of a cleaned filter bowl, the bowl should be filled with new filtered hydraulic fluid from an authorized servicing unit.
1. True
 2. False
- 10-34. What type of accumulator is most commonly used in high-pressure hydraulic systems?
1. The ball type
 2. The diaphragm type
 3. The spherical type
 4. The cylindrical type
- 10-35. Which of the following components is/are NOT a part of a cylindrical type accumulator?
1. Rubber diaphragm
 2. Piston assembly
 3. Cylinder
 4. End caps
- 10-36. You can preload an accumulator by using which of the following procedures?
1. Pressurizing the fluid chamber with compressed air
 2. Filling the fluid chamber with a prescribed amount of fluid
 3. Inflating the air chamber to a predetermined pressure below the system operating pressure
 4. Inflating the air chamber to a predetermined pressure above the system operating pressure

- 10-37. Most naval aircraft are equipped with air pressure gauges to read the preload of an accumulator after relieving hydraulic system pressure.
1. True
 2. False
- 10-38. To indicate the amount of pressure in a hydraulic system, naval aircraft use what two types of pressure gauges?
1. Synchro and electric
 2. Direct-reading and synchro
 3. Direct-reading and Bourdon
 4. Direct-reading and indirect-reading
- 10-39. The Bourdon tube in a direct-reading pressure gauge is operated by what means?
1. Spring action
 2. Fluid pressure
 3. Electrical current
 4. Mechanical linkage
- 10-40. A synchro-type pressure indicator transmits what type of signal from the synchro to the indicator?
1. Pneumatic
 2. Hydraulic
 3. Mechanical
 4. Electrical
- 10-41. To prevent damage to gauges and pressure transmitters, hydraulic systems use which of the following components?
1. Pressure regulators
 2. Restrictor valves
 3. Snubbers
 4. Buffers
- 10-42. An aircraft emergency power system pump can be powered by which of the following methods?
1. A hand pump only
 2. A ram-air turbine only
 3. An electric motor only
 4. A hand pump, a ram-air turbine, or an electric motor
- 10-43. The pressure switch of an electric, motor-driven, emergency power system is actuated by what means?
1. Manually, by the pilot
 2. Mechanically, by the pump motor
 3. Automatically, by hydraulic pressure
 4. Electrically, by the emergency switch
- 10-44. The ram-air turbine assembly of an emergency power system is extended into the slipstream by (a) what means and (b) during what condition?
1. (a) Automatically
(b) when a hydraulic failure occurs
 2. (a) Automatically
(b) when an engine failure occurs
 3. (a) Manually
(b) when released from the cockpit
 4. (a) Electronically
(b) when released from the cockpit
- 10-45. Extension of the ram-air turbine assembly is initiated by what force acting on the turbine actuator?
1. Gravity
 2. Airstream
 3. Spring-loaded
 4. Hydraulic pressure
- 10-46. The air compressor in an aircraft pneumatic system is supplied air from what source?
1. An electric-driven fan
 2. The aircraft engine
 3. A ram-air turbine
 4. The ambient air
- 10-47. The air compressor in an aircraft pneumatic system is operated by what means?
1. A mechanical motor
 2. An electric motor only
 3. A hydraulic motor only
 4. An electric or hydraulic motor
- 10-48. In an aircraft pneumatic system, the moisture separator is always in which of the following locations?
1. Downstream of the compressor
 2. Downstream of the reservoir
 3. Upstream of the compressor
 4. Upstream of the reservoir
- 10-49. A chemical air drier cartridge is NOT contaminated when it is what color?
1. Red
 2. Blue
 3. Pink
 4. White

10-50. Pneumatic storage cylinders are used in aircraft pneumatic systems for which of the following purposes?

1. To store air only
2. To serve as a moisture trap only
3. To store air and serve as a moisture trap
4. To serve as a pneumatic shutoff valve while in flight

10-51. If the instruction plate is missing from an air storage cylinder, you can find servicing information in which of the following publications?

1. IPB
2. MIM
3. MRC
4. NATOPS

ASSIGNMENT 11

Textbook Assignment: "Landing Gear Systems," chapter 13, pages 13-1 through 13-20. "Brake Systems," chapter 14, pages 14-1 through 14-37.

- 11-1. What is the most common type of landing gear used on naval aircraft?
1. Bicycle
 2. Tricycle
 3. Inverted
 4. Indented
- 11-2. The main landing gear struts are attached to what points on an aircraft?
1. Strong members of the wings and fuselage
 2. Strong members of the fuselage
 3. Strong members of the wings
 4. Centerline on the fuselage
- 11-3. What component of a nose land gear prevents oscillation or shimmying of the nose wheel?
1. The nose wheel
 2. The shock strut
 3. The scissor arms
 4. The nose wheel steering mechanism
- 11-4. The H-60 helicopter main landing gear consists of which of the following components?
1. Left and right retractable gear
 2. Left and right nonretractable gear
 3. Left and right retractable gear and weight-on-wheels switch
 4. Left and right nonretractable gear and weight-on-wheels switch
- 11-5. The H-60 helicopter has what type of tail landing gear system?
1. Single-wheel, nonlocking tail wheel
 2. Dual-wheel, nonlocking tail wheel
 3. Single-wheel, locking-tail wheel
 4. Dual-wheel, locking tail wheel
- 11-6. When the landing gear is fully retracted in a typical aircraft landing gear system, the up lock mechanism is actuated by what means?
1. Electrically
 2. Mechanically
 3. Hydraulically
 4. Pneumatically
- 11-7. When a landing gear system is in the up and locked position, what is indicated on the pilot's position indicator windows?
1. Wheels
 2. Barber poles
 3. Up
 4. Blank windows
- 11-8. After the locks are disengaged in the emergency landing gear extension system, what force(s) extend (s) the main gear?
1. Gravity only
 2. Nitrogen only
 3. Hydraulic pressure only
 4. Gravity, nitrogen, and hydraulic pressure
- 11-9. An up-lock switch is installed on each main landing gear door latch to provide (a) what indication and (b) in what location?
1. (a) Main-gear-down
(b) wheel well
 2. (a) Main-gear-up
(b) wheel well
 3. (a) Main-gear-down
(b) cockpit
 4. (a) Main-gear-up
(b) cockpit
- 11-10. When trimming off the excess material of a new landing gear door, the landing gear must be in what configuration?
1. Retracted and door linkage disconnected
 2. Retracted and door linkage connected
 3. Extended and door linkage disconnected
 4. Extended and door linkage connected
- 11-11. What component (s) of a landing gear system is/are used to maintain the specific allowable clearance of a landing gear door?
1. The upper drag brace
 2. The lower drag brace
 3. Actuating cylinder and connecting links
 4. The door hinges and connecting links

- 11-12. The rate of flow from the lower chamber to the upper chamber of the landing gear shock strut is controlled by what component?
1. The air valve
 2. The torque arm
 3. The metering pin
 4. The orifice plate
- 11-13. What is the purpose of the packing gland on a main landing gear shock strut?
1. Clean the upper piston
 2. Clean the lower piston
 3. Seal the joint between the upper and lower telescoping cylinders
 4. Connect the joints between the upper and lower telescoping cylinders
- 11-14. When the nose gear shock strut is fully extended, the wheel axle assembly is aligned in a straight-ahead position by which of the following components?
1. The cylinder
 2. The torque arm
 3. The centering cams
 4. The fork and axle assembly
- 11-15. Where on a landing gear system can you find the instruction plate for servicing the shock strut?
1. On the landing gear door
 2. On the trunnion assembly
 3. On the drag brace assembly
 4. On the strut near the air valve
- 11-16. If a strut is NOT serviced with the proper amounts of fluids and nitrogen, what action will occur during a landing?
1. The strut will bottom out
 2. The strut will lock in the fully extended position
 3. The strut will lock in the fully retracted position
 4. The strut will operate normally
- 11-17. The landing gear drag brace is hinged at the center for which of the following reasons?
1. To facilitate maintenance
 2. To facilitate proper inspections
 3. To permit the brace to jackknife during gear extension
 4. To permit the brace to jackknife during gear retraction
- 11-18. What is the first step in adjusting a main landing gear drag brace?
1. Disconnect the upper drag brace
 2. Disconnect the lower drag brace
 3. Remove the nut and cotter pin from the lock arm shaft
 4. Rotate the eccentric bushing
- 11-19. When performing a drop check with the test stand set at 3,000 psi and 3 gpm, how long should it take the gear to make a complete up and down cycle?
1. 3 to 5 seconds
 2. 5 to 8 seconds
 3. 9 to 11 seconds
 4. 12 to 14 seconds
- 11-20. What is the first step in performing an emergency landing gear system drop check once you have the aircraft on jacks and hydraulic and electrical power hooked up to the aircraft?
1. Place the landing gear handle in the down position
 2. Retract the gear normally
 3. Secure hydraulic pressure
 4. Pull and hold the emergency extension handle
- 11-21. A significant number of unsafe or hung landing gear discrepancies are caused by which of the following maintenance related problems?
1. Improper rigging only
 2. Improper adjustment of linkages only
 3. Improper rigging or improper adjustment of linkages
 4. Improper rigging, improper adjustment of linkages, or factory defective parts
- 11-22. When checking a newly installed main landing gear shock strut for alignment and adjustment, what must you do to the landing gear system?
1. Deflate the shock strut
 2. Landing gear doors must be disconnected
 3. The tire must be removed
 4. The brakes must be removed
- 11-23. When replacing a gland seal on a shock strut at organizational level, what is the first step once the aircraft is on jacks?
1. Remove the wheel and brake assembly
 2. Remove the air valve cap
 3. Remove the nitrogen pressure
 4. Remove all hydraulic lines and wire bundles

- 11-24. You can release the nitrogen pressure from a shock strut by which of the following means?
1. Removing the valve core
 2. Depressing the valve core
 3. Turning the swivel nut clockwise
 4. Turning the swivel nut counterclockwise
- 11-25. When removing a shock strut from an aircraft, what is the first step you should take?
1. Deflate the strut
 2. Jack the aircraft
 3. Remove the tire/wheel
 4. Bleed hydraulic pressure from the system
- 11-26. What is the final step when replacing a shock strut on an aircraft?
1. Service the strut
 2. Bleed the brakes
 3. Install the tire/wheel
 4. Check the landing gear for proper operation
- 11-27. To ensure complete compression when deflating a typical shock strut, you may need to perform which of the following functions?
1. Rock the aircraft
 2. Hoist the aircraft
 3. Lower the arresting gear
 4. Bleed the landing gear accumulator
- 11-28. What is the proper procedure for removing the air valve from a shock strut?
1. Turn the 3/4-inch body nut clockwise
 2. Turn the 3/4-inch body nut counterclockwise
 3. Cut the safety wire and turn the 3/4-inch body nut counterclockwise
 4. Cut the safety wire and turn the 3/4-inch body nut clockwise
- 11-29. After you have serviced a shock strut, the air valve swivel nut should be tightened to what torque?
1. 20 to 30 inch pounds
 2. 50 to 70 inch pounds
 3. 80 to 90 inch pounds
 4. 100 to 110 inch pounds
- 11-30. What must be done to a strut if it continues to leak after you have tightened the packing gland nut?
1. Bleed the strut
 2. Deflate and reservice the strut
 3. Tighten the gland nut another 10 foot-pounds
 4. Disassemble the strut and replace the packings
- 11-31. What must be done to a shock strut at intermediate level before disassembling the inner and outer cylinders?
1. Disconnect the inner cylinder from the outer cylinder
 2. Ensure all pressure is exhausted from the strut
 3. Remove the air valve assembly
 4. Ensure all hydraulic fluid is drained
- 11-32. At intermediate level, once you have removed the air valve from a strut, what is the next step when rebuilding a strut?
1. Drain the hydraulic fluid
 2. Remove the gland nut
 3. Extend the strut
 4. Fill the strut with hydraulic fluid
- 11-33. What is used to clean the parts of a disassembled shock strut?
1. Filtered hydraulic fluid
 2. Water
 3. Freon
 4. Dry-cleaning solvent
- 11-34. After they have been cleaned, parts of the strut that normally come in contact with fluid should be coated with what substance?
1. VV-L-800
 2. General lubricating oil
 3. Hydraulic fluid
 4. Grease
- 11-35. When inspecting the machined surfaces of a disassembled strut, you should look for corrosion, abrasions, gouges, grooves, scores, scratches, and what other discrepancy?
1. Burrs
 2. Nicks
 3. Roughness
 4. Mars

- 11-36. When inspecting a strut assembly at an intermediate maintenance activity, what tool should you use to check the bearings for residual magnetism?
1. A dial indicator
 2. A sensitive compass
 3. A mattock
 4. A magnet
- 11-37. What does the term *Brinelling* mean when you are inspecting the bearings of a shock strut?
1. Shallow indentations in the raceway
 2. Loose rollers
 3. Binding rollers
 4. Warpage of the bearing retainer
- 11-38. Shock strut bearing retainers should be inspected for cracks, warpage, and what other discrepancy?
1. Roughness
 2. Mars
 3. Abrasions
 4. Corrosion
- 11-39. What type of tool is used for replacing O-rings in a disassembled shock strut machined surface?
1. Scribe
 2. Brass tool
 3. Screwdriver
 4. Awl
- 11-40. What should be used to blend out minor scratches, nicks, and burrs from a machined surface of a steel part?
1. Grinding wheel
 2. Flap brush
 3. Crocus cloth
 4. Scribe
- 11-41. What type of damage will condemn the inner cylinder of a shock strut from further service?
1. Partial removal of plating
 2. Corrosion
 3. Nicks
 4. Roughness
- 11-42. If a bushing on a shock strut needs to be replaced, what must be done to the mating bushing?
1. Clean it
 2. Replace it
 3. Lubricated it
 4. File it
- 11-43. When specific torque values for strut assembly threaded parts are NOT specified in the 03 manual or MIM, what publication should you consult?
1. NAVAIR 01-1A-509
 2. NAVAIR 01-1A-16
 3. NAVAIR 01-1A-12
 4. NAVAIR 01-1A-8
- 11-44. What is used to secure the gland nut of a shock strut once it has been tightened?
1. Cotter pins
 2. Clip locks
 3. Two screws and safety wire
 4. Roll pin
- 11-45. What must be done to a strut that fails a bench test at intermediate-level maintenance?
1. Deflate and reservice
 2. Tighten the gland nut
 3. Replace the packings
 4. Forward to next higher level of maintenance
- 11-46. What must be done to a strut that passes the bench test but is not installed on an aircraft immediately before it goes to supply?
1. Deflate the strut
 2. Drain the hydraulic fluid
 3. Flush it with preservative hydraulic fluid
 4. Fill it with compressed air
- 11-47. What type of report must accompany a strut that has been removed for unusual failure or malfunction?
1. Quality Deficiency Report (QDR)
 2. Hazardous Material Report
 3. Engineering investigation
 4. Technical Publication Deficiency Report
- 11-48. Fluid is routed to a Goodyear master cylinder by (a) what method and from (b) what source?
1. (a) Gravity
(b) external reservoir
 2. (a) Gravity
(b) internal reservoir
 3. (a) Hydraulic pump
(b) external reservoir
 4. (a) Hydraulic pump
(b) internal reservoir

- 11-49. An independent-type brake system employing a Goodyear master cylinder must be bled by what method?
1. Top up
 2. Top down
 3. Bottom up
 4. Bottom down
- 11-50. In a power boost brake system, main hydraulic system pressure is used for what purpose?
1. To assist in pedal movement only
 2. To operate the emergency system only
 3. To assist in pedal movement and operate the emergency system
 4. To assist in pedal movement, operate the emergency system, and actuate the brake cylinders
- 11-51. The brake pedal linkage of a power brake control valve (pressure ball check type) system is connected to the control valve by what component?
1. A link
 2. A shackle
 3. A tuning fork
 4. A piston shaft
- 11-52. What is the purpose of a brake deboosters cylinder?
1. To increase the pressure and decrease the volume of fluid flow to the brake
 2. To decrease the pressure and increase the volume of fluid flow to the brake
 3. To decrease both the pressure and the volume of fluid flow to the brake
 4. To increase both the pressure and the volume of fluid flow to the brake
- 11-53. The brake linings of a single disc brake assembly are known by what term?
1. Discs
 2. Pucks
 3. Rotors
 4. Plates
- 11-54. To give correct clearances between the rotating and stationary discs in a multiple/trimetallic brake system, what device traps a predetermined amount of fluid in the brake?
1. The stator
 2. The backup ring
 3. The annular piston
 4. The automatic adjuster
- 11-55. In an independent brake system, the reservoir fluid level is checked by what means?
1. A dip stick
 2. A sight gauge
 3. A cockpit indicator
 4. A lower ring in the filler neck
- 11-56. To perform an operational check on the emergency brake system, what source of external power, if any, is required?
1. Pneumatic
 2. Hydraulic
 3. Electrical
 4. None
- 11-57. What factor(s) generally determine(s) the method you should use for bleeding brake systems?
1. The amount of air in the system
 2. The type and design of the brake system to be bled
 3. The means by which the brake is mounted on the strut
 4. The type of main hydraulic system used in the aircraft
- 11-58. An overheated wheel brake assembly should be allowed to cool in the ambient air for what prescribed amount of time?
1. 45 to 60 min
 2. 35 to 45 min
 3. 30 to 40 min
 4. 15 to 25 min
- 11-59. The independent brake system reservoir leakage test is performed by connecting a source of air to the filler port at what prescribed pressure?
1. 25 psi
 2. 30 psi
 3. 35 psi
 4. 50 psi
- 11-60. To perform an operational test on a power brake valve, you must have a test stand capable of supplying what minimum amount of hydraulic pressure?
1. 1500 psi
 2. 2000 psi
 3. 3000 psi
 4. 4500 psi

- 11-61. When you are performing an operational test on a power/manual brake valve, the hydraulic fluid must be within what prescribed temperature range?
1. 40° to 90°F
 2. 55° to 100°F
 3. 70° to 110°F
 4. 85° to 130°F
- 11-62. Before disassembling a master brake cylinder, what device should you install on the end of the piston rod to prevent personal injury?
1. A nut
 2. A clamp
 3. A rig pin
 4. A spring compressor
- 11-63. During the reassembly of a master brake cylinder, what type of lubricant should you apply to the suspension rod end bearing?
1. Oil
 2. Wax
 3. Grease
 4. Hydraulic fluid
- 11-64. Excessive heating of a shuttle valve is an indication of what problem?
1. External leakage
 2. Internal leakage
 3. Defective emergency accumulator
 4. Excessive cycling of the emergency pump
- 11-65. When performing a thermal crack test on an automatic brake adjuster valve, you should crack the valve at what prescribed pressure range?
1. 12 to 17 psi
 2. 20 to 29 psi
 3. 30 to 37 psi
 4. 41 to 45 psi
- 11-66. After disassembling a brake selector valve, you should clean the parts in which of the following substances?
1. Freon
 2. Hydraulic fluid
 3. Aliphatic naphtha
 4. Dry-cleaning solvent
- 11-67. During a bench test, what is the maximum allowable torque required to rotate the swivel?
1. 30 in.-lb
 2. 40 in.-lb
 3. 50 in.-lb
 4. 60 in.-lb
- 11-68. When the brakes are released, what component prevents the piston from returning to its original position?
1. The spring guide
 2. The adjusting pin
 3. The return spring
 4. The retaining ring
- 11-69. The tapered grip method is used to restrict the movement of the captured torquing-type automatic adjuster?
1. True
 2. False
- IN ANSWERING QUESTION 11-70, REFER TO FIGURE 14-30.
- 11-70. The disc guide lining is attached to the disc guide by which of the following items?
1. Nuts
 2. Pins
 3. Bolts
 4. Rivets
- 11-71. When pressure testing a dual disc brake assembly for leaks, you should hold the test pressure for what total number of minutes?
1. 5 min
 2. 2 min
 3. 3 min
 4. 4 min
- 11-72. During brake application in a trimetallic disc brake assembly, the braking force is directly transmitted to which of the following components?
1. The brake pistons
 2. The rotating disc
 3. The self-adjusting mechanism
 4. The pressure plate subassembly
- 11-73. The rotating disc of a trimetallic disc brake must be replaced if it is worn below what prescribed thickness?
1. 0.1 in.
 2. 0.2 in.
 3. 0.3 in.
 4. 0.4 in.

11-74. You are testing a trimetallic disc brake and have 90 psi applied to the brake assembly. What is the minimum clearance you must have between the pressure plate and the first rotating disc?

1. 0.045 in.
2. 0.055 in.
3. 0.065 in.
4. 0.075 in.

ASSIGNMENT 12

Textbook Assignment: "Utility Hydraulic Systems," chapter 15, pages 15-1 through 15-21. "Fixed-Wing Flight Control Systems," chapter 16, pages 16-1 through 16-7.

- 12-1. Hydraulically actuated nosewheel steering systems are controlled by which of the following methods?
1. Manually
 2. Electrically only
 3. Mechanically only
 4. Electrically or mechanically
- 12-2. In a nosewheel steering system, what component generates an electrical signal proportional to the amount of deflection?
1. The feedback potentiometer
 2. The command potentiometer
 3. The steering transducer
 4. The steering amplifier
- 12-3. What integral type of arresting hook has a Metco-coated hook point?
1. Type I
 2. Type II
 3. Type III
 4. Type IV
- 12-4. An arresting gear detachable hook point should be removed and inspected after what total number of arrestments?
1. 10
 2. 12
 3. 15
 4. 25
- 12-5. What is the maximum operating pressure within a liquid centering spring assembly when it is bottomed out?
1. 1,000 psi
 2. 10,000 psi
 3. 20,000 psi
 4. 50,000 psi
- 12-6. The arresting hook assembly must be lowered to adjust the liquid centering spring.
1. True
 2. False
- 12-7. In a catapult system, the launch bar moves down and encloses the two horns on the nose gear axle beam enabling what action to take place?
1. The launch bar to remain straight
 2. The launch bar to steer the nose gear
 3. The launch bar to be attached to the tension bar
 4. The launch bar to be locked in the extend position
- 12-8. If automatic retraction fails, what components will raise the launch bar to the retracted position?
1. The leaf springs
 2. The coil springs
 3. The locking fingers
 4. The nose axle beam horns
- 12-9. You are performing an operational test of the air refueling probe system. What is the prescribed time range for the complete (a) extension cycle and (b) retraction cycle?
1. (a) 1 to 3 sec
(b) 4 to 7 sec
 2. (a) 2 to 5 sec
(b) 5 to 9 sec
 3. (a) 3 to 5 sec
(b) 6 to 8 sec
 4. (a) 5 to 7 sec
(b) 9 to 11 sec
- 12-10. In a wing fold system, what device prevents the wing fold handle from moving past the first stop when you are folding the wings?
1. A hydraulic lock at the wing lock cylinder
 2. A hydraulic lock at the wing fold cylinder
 3. A spring-loaded mechanical latch at the wing lock cylinder
 4. A spring-loaded mechanical latch at the wing fold cylinder

- 12-11. In a wing fold system, the spring-loaded check ball of the thermal relief valve reseats at what prescribed pressure?
1. 4,150 psi
 2. 3,970 psi
 3. 3,590 psi
 4. 3,360 psi
- 12-12. If the wing lock warning flags in a wing fold system fail to retract, you should consider this an indication of what problem?
1. The lockpins are failing to properly enter the lock fittings
 2. The wing lock timer valve is not functioning
 3. The hydraulic system pressure is insufficient
 4. The wing fold cylinder is defective
- 12-13. In an ac generator drive system (hydraulically operated), when the return fluid exits the motor, it is routed through a heat exchanger and is cooled by what means?
1. By fuel
 2. By ram air
 3. By a compressor
 4. By an electrically driven blower unit
- 12-14. To prevent overtemperature and/reverse airflow in the engine compartment, the variable bypass bellmouth system is supplemented at low airspeeds and during ground operations by which of the following units?
1. The bellmouth ring
 2. The aft variable ramp
 3. The auxiliary air doors
 4. The front variable ramp
- 12-15. When the control valve is in the neutral position in a bomb bay system, the doors are held closed by what means?
1. A check valve
 2. Mechanical locks
 3. Hydraulic pressure
 4. A hydraulic lock valve
- 12-16. When you are adjusting the blades to the parking area in a windshield wiper system, rotating a blade one serration will equal approximately how many degrees rotation?
1. 10°
 2. 2°
 3. 3°
 4. 5°
- 12-17. Pitch, yaw, and roll control of an aircraft are provided by what flight controls?
1. Primary
 2. Backup
 3. Secondary
 4. Auxiliary
- 12-18. What type of flight control system is moved manually through a series of push-pull rods, cables, bell cranks, sectors, and idlers?
1. Mechanical (unboosted)
 2. Mechanical (boosted)
 3. Power-assisted
 4. Power-boosted
- 12-19. Specifications for Navy aircraft require that the primary flight control surfaces be capable of operating from what total number of separate hydraulic systems?
1. One
 2. Two
 3. Three
 4. Four
- 12-20. An aircraft elevator control system has viscous dampers on the bobweight assemblies for what purpose?
1. To decrease control stick load
 2. To reduce push-pull tube vibration
 3. To retard control stick movement to prevent overcontrol
 4. To help the pilot move the stick from the neutral position
- 12-21. To balance the forward and aft bobweights when an aircraft elevator is in a neutral position, what component is installed between the bell crank and the fin structure?
1. A load-feel bungee
 2. A push-pull tube
 3. A truss assembly
 4. A load spring
- 12-22. Horizontal stabilizer movement is controlled only by input signals from the AFCS system when it is functioning in what mode?
1. Manual
 2. Series
 3. Parallel
 4. Independent

- 12-23. To provide longitudinal trim to the aircraft, an electric trim actuator is linked to the artificial-feel bungee in what manner?
1. Electrically
 2. Mechanically
 3. Hydraulically
 4. Pneumatically
- 12-24. The approach power compensator system (APC) aids the pilot in what manner?
1. It regulates the position of the flap's power mechanism during the approach for landing
 2. It maintains a fixed angle of attack during landing to compensate for varying gross weight
 3. It maintains a varying spoiler deflector position during landing to compensate for varying approach speeds
 4. It regulates the throttle position to maintain the desired angle of attack during approaches and landings
- 12-25. An aircraft lateral control system incorporates a load-feel bungee in the aileron system for which of the following purposes?
1. To provide artificial feel only
 2. To provide a centering device only
 3. To provide artificial feel and a centering device only
 4. To provide artificial feel, a centering device, and effortless control stick movement
- IN ANSWERING QUESTION 12-26, REFER TO FIGURE 16-10 IN THE TEXTBOOK.
- 12-26. The aircraft flaperon control system has a total of how many actuators?
1. Five
 2. Two
 3. Three
 4. Seven
- 12-27. Flaperon autopilot actuators are capable of operating in which of the following modes?
1. Manual only
 2. Manual or series only
 3. Manual, series, or parallel
 4. Manual, series, parallel, or independent
- 12-28. When the flaperon autopilot actuator is operating in the series mode, the AFCS can be overridden by the pilot applying what minimum amount of force to the control stick?
1. 25 lb
 2. 20 lb
 3. 15 lb
 4. 10 lb
- 12-29. The combination aileron and spoiler/deflector system is used to enhance what in-flight capability of the aircraft?
1. Increased pitch control in rapid descents
 2. Increased climb rate about the lateral axis
 3. Increased yaw control during high-speed turns
 4. Increased roll rate about the longitudinal axis
- 12-30. On a combination aileron and spoiler/deflector system, what is the maximum degree of deflection of (a) the spoiler and (b) the deflector?
1. (a) 30° (b) 15°
 2. (a) 40° (b) 20°
 3. (a) 50° (b) 25°
 4. (a) 60° (b) 30°
- 12-31. In a spoiler control system, spoiler action is provided by all EXCEPT which of the following components?
1. The pitch computer
 2. The spoiler actuators
 3. The mechanical interlock
 4. The roll command transducer
- 12-32. In a rudder control system, the pedal position transmitter and the rudder surface transmitter function only under which of the following conditions?
1. When the automatic flight control system is disengaged
 2. When the automatic flight control system is engaged
 3. When the nosewheel steering system is disengaged
 4. When the nosewheel steering system is engaged

- 12-33. The servo cylinders used in an electronic flight control system are controlled by what means?
1. Mechanical linkage
 2. Electrically controlled cables
 3. Electrical impulses from computers
 4. Hydraulic impulses from electronic data centers
- 12-34. The backup flight control system reservoir has what total capacity?
1. 0.84 quart
 2. 0.97 quart
 3. 1.31 quarts
 4. 1.75 quarts
- 12-35. The three-position backup system hydraulic test switch located in the cockpit is spring-loaded to what position?
1. ON
 2. OFF
 3. FLIGHT
 4. COMBINED
- 12-36. If a jammed flight control system malfunction can NOT be duplicated or the cause determined, you should take which of the following actions?
1. Request a P&E inspection
 2. Make an aircraft logbook entry
 3. Make at least three penalty flights
 4. Request a NADEP evaluation of the aircraft
- 12-37. When analyzing trouble in flight control systems, a quality assurance inspection is a must during which of the following stages of repair?
1. The testing stage only
 2. The completion stage only
 3. The repair progression stage only
 4. The testing, completion, and repair progression stages
- 12-38. Readjustment of primary flight control power actuators should be accomplished at which of the following maintenance activities?
1. Depot level only
 2. Intermediate level only
 3. Depot or intermediate level only
 4. Depot, intermediate, or organizational level
- 12-39. Flutter, free play, and sluggishness of control surfaces are usually the result of which of the following problems?
1. Broken cables
 2. Low cable tension
 3. High cable tension
 4. Freely rotating pushrods and bell cranks
- 12-40. Control surface throws may be measured in which of the following units?
1. Inches only
 2. Inches and degrees only
 3. Inches, fractions, or degrees only
 4. Inches and fractions or degrees and minutes
- 12-41. In reference to a cable control system, which of the following statements is NOT correct?
1. Cables are rigid
 2. Cables can be run over long distances
 3. Cables are easily led around obstacles
 4. Cables are stronger than steel rods or tubing
- 12-42. Cable control systems require more maintenance and must be inspected more thoroughly than rigid linkage systems.
1. True
 2. False
- 12-43. If you find a cable that is kinked, what action should you take?
1. The kink should be noted in the aircraft logbook and the cable removed during the next periodic inspection
 2. The cable should be thoroughly cleaned and the kink removed
 3. The kink should be straightened and the cable lubricated
 4. The cable should be replaced immediately
- 12-44. To replace cables in an aircraft when they are routed through inaccessible areas, you should use which of the following items?
1. A tensiometer
 2. A snaking line
 3. A swaging device
 4. A fairlead guide

- 12-45. To ensure that the end fitting of a push-pull rod is NOT extended too far out of the rod, you should follow which of the following procedures?
1. Retighten the checknut
 2. Measure the end fitting length
 3. Count the number of end fitting turns
 4. Look for the stem through the drilled hole in the rod

IN ANSWERING QUESTIONS 12-46 THROUGH 12-48, SELECT FROM COLUMN B THE COMPONENT THAT BEST MATCHES THE FUNCTION LISTED IN COLUMN A. NOT ALL ITEMS LISTED IN COLUMN B WILL BE USED.

<u>A. FUNCTION</u>	<u>B. COMPONENT</u>
12-46. Changes the direction of motion	1. Bungee 2. Idler arm
12-47. Supports and guides push-pull tubes assembly	3. Bell crank 4. Fitting
12-48. Protects the rigid system against damage	
12-49. Basically, what total number of distinct steps are there to follow in aircraft troubleshooting?	
	1. Ten 2. Nine 3. Three 4. Seven
12-50. A tensiometer is used to measure and check which of the following items?	
	1. The length of a cable 2. The breaking strength of a cable 3. The amount a cable will stretch 4. The amount of pulling force applied to a cable

IN ANSWERING QUESTION 12-51, REFER TO FIGURE 16-23 IN THE TEXTBOOK.

- 12-51. You are checking a 1/8-inch cable using a No. 1 riser, and the dial pointer indicates 33. What is the cable tension?
1. 50 lb
 2. 60 lb
 3. 70 lb
 4. 80 lb
- 12-52. Cable tensiometer readings should NOT be taken within what prescribed number of inches of turnbuckles, end fittings, or quick disconnects?
1. 5 in.
 2. 2 in.
 3. 6 in.
 4. 4 in.

IN ANSWERING QUESTIONS 12-53 THROUGH 12-55, REFER TO FIGURE 16-26 IN THE TEXTBOOK.

- 12-53. You should begin rigging the system at what component?
1. The bobweight
 2. The aft sector
 3. The bell crank
 4. The aft control stick
- 12-54. While rigging the elevator control system, you have the aft sector rig pin in place and you find that the elevators are 5 degrees too low. What action should you take to correct the problem?
1. Loosen the turnbuckles on the cables
 2. Tighten the turnbuckles on the cables
 3. Shorten the push-pull rod from the aft sector
 4. Lengthen the push-pull rod from the forward sector
- 12-55. The maximum up and down travel of the aircraft elevators is controlled by the adjustment of which of the following components?
1. The stop bolts on the aft control stick
 2. The stop bolts on the forward control stick
 3. The forward push-pull tube at the aft control stick
 4. The vertical reference line at the forward control stick

ASSIGNMENT 13

Textbook Assignment: "Fixed-Wing Flight Control Systems," chapter 16, pages 16-8 through 16-57.
"Rotary-Wing Flight Control Systems," chapter 17, pages 17-1 through 17-20.

- 13-1. Aircraft control cables should NOT be cut by which of the following tools?
1. A cold chisel
 2. A pair of side cutters
 3. An oxyacetylene cutting torch
 4. A pair of heavy-duty diagonal pliers
- 13-2. Swaging is the attachment of a terminal to the end of a cable by what means?
1. By soldering
 2. By pressure
 3. By welding
 4. By heat
- 13-3. After a cable terminal has been swaged and measured, what manual should you consult to determine if it has been swaged sufficiently?
1. NAVAIR O1-1A-8
 2. NAVAIR O1-1A-12
 3. NAVAIR O1-1A-16
 4. NAVAIR O1-1A-20
- 13-4. What amount of cable should extend through an MS 20667 terminal when you swag it with a pneumatic swagger?
1. 1/8 in.
 2. 1/4 in.
 3. 1/2 in.
 4. 3/4 in.
- 13-5. Usually, wing flaps are hydraulically operated and controlled by which of the following methods?
1. Pneumatically
 2. Electrically only
 3. Mechanically only
 4. Electrically or mechanically
- 13-6. In a conventional wing flap system, what condition ensures that the wing flaps will be locked in the full up position?
1. The spring pressure exerted by the follow-up pushrod
 2. The flap control handle in its detent position
 3. The selector valve slightly displaced from neutral
 4. The selector valve in neutral
- 13-7. In a conventional wing flap system, a wing flap retraction shutoff valve is energized during which of the following conditions?
1. When the aircraft's weight is on its wheels
 2. When the aircraft is in flight with the flaps up
 3. When the aircraft is in flight with the landing gear up
 4. When the aircraft is experiencing an in-flight split flap condition
- 13-8. Once actuated, the emergency dump valve of a conventional wing flap system must be reset by what method to restore the system to normal operation?
1. Manually
 2. Electrically
 3. Pneumatically
 4. Hydraulically
- 13-9. On some aircraft, leading edge flap panels are known as slats.
1. True
 2. False
- 13-10. In a leading/trailing edge wing flap system, what indication will appear in the windows of the flap position indicator when the flaps are in transit?
1. UP
 2. DN
 3. NEU
 4. Barber poles

- 13-11. When the emergency flap system has been actuated, in what position are (a) the leading edge flaps and (b) the trailing edge flaps?
1. (a) Up (b) 1/2 down
 2. (a) Up (b) full down
 3. (a) 1/2 down (b) full down
 4. (a) Full down (b) 1/2 down
- 13-12. If the combined hydraulic system fails in a semi-independent flap and slat system, what component provides for continued operation of the system?
1. An accumulator
 2. A shuttle valve
 3. An emergency pneumatic pump
 4. An emergency electric motor
- 13-13. In a semi-independent flap and slat system, if the flap control handle is moved to the takeoff position, a limit switch will halt flap movement at what position?
1. 10°
 2. 20°
 3. 30°
 4. 40°
- 13-14. The slat system provides which of the following aerodynamic features?
1. Higher takeoff speeds
 2. Increased turning radius
 3. Additional lift and stability at lower speeds
 4. Additional lift and stability at higher speeds
- 13-15. Direct lift control (DLC) is incorporated into some aircraft to perform what function?
1. To decrease the vertical descent rate of the aircraft during landings
 2. To increase the vertical descent rate of the aircraft during landings
 3. To decrease the ascent rate of the aircraft during takeoffs
 4. To increase the ascent rate of the aircraft during takeoffs
- 13-16. What component in a wing surface control system ensures symmetrical operation of the wings?
1. A flow divider
 2. A sweep control box
 3. An air data computer
 4. A synchronizing shaft
- 13-17. Minimum wing sweep limiting is NOT available under what method of control?
1. Automatic
 2. Mechanical
 3. Electronic
 4. Bomb manual
- 13-18. Aircraft that incorporate fuselage type speed brakes have an interconnect between the left-hand speed brake and the elevator nose-down control cable for what purpose?
1. To stabilize aircraft yaw when the speed brakes are actuated
 2. To prevent the aircraft from assuming a nose up attitude when the speed brakes are extended
 3. To prevent the aircraft from assuming a nose down attitude when the speed brakes are extended
 4. To assist the pilot in bringing the nose of the aircraft up when the speed brakes are applied
- 13-19. To allow for automatic retraction under high air loads, what type of valve is installed in a fuselage speed brake system?
1. A check valve
 2. A restrictor valve
 3. A blow-back relief valve
 4. A solenoid control valve
- 13-20. During a malfunction, the null detector of the wingtip speed brake system causes the speed brakes to close when they reach what maximum amount of disparity?
1. 8°
 2. 12°
 3. 15°
 4. 21°
- 13-21. A trim system is provided for the pilot to lessen the need for a constant effort to maintain the desired heading and altitude.
1. True
 2. False
- 13-22. When the AFCS is engaged, what type of input controls the trim actuator in the aileron trim control system?
1. Hydraulic
 2. Pneumatic
 3. Electrical
 4. Mechanical

- 13-23. A longitudinal trim actuator has what total number of operating speeds?
1. One
 2. Two
 3. Four
 4. Five
- 13-24. The proper operation of gearboxes, inter-connecting splined shafts, and screw jack actuators is essentially dependent upon which of the following maintenance functions?
1. Correct alignment
 2. Correct adjustment
 3. Proper lubrication
 4. Proper installation
- 13-25. During the repair process for flap hydraulic components, you should verify spring alignment by performing which of the following procedures?
1. Testing them with a load tester
 2. Rolling them on a smooth, flat surface
 3. Rolling them on a smooth, curved surface
 4. Testing them with a spring alignment tester
- 13-26. When a wing or stabilizer has been removed from an aircraft, it should be sent to what type of repair facility?
1. Organizational-level
 2. Intermediate-level
 3. Manufacturer
 4. Depot-level
- 13-27. Which of the following tools are recommended for the removal of wing structural bolts?
1. A mallet and brass drift pin
 2. A ball-peen hammer and chisel
 3. A setting hammer and prick punch
 4. A sledge hammer and sheet metal punch
- 13-28. Before disconnecting cable linkage from flight control surfaces, you should perform what function first?
1. Jack the aircraft
 2. Relieve the tension
 3. Collapse the struts
 4. Apply hydraulic power
- 13-29. An alignment check of the airframe should be made if an aircraft has experienced which of the following conditions?
1. Excessive g acceleration only
 2. Extensive damage only
 3. A hard landing only
 4. Excessive g acceleration, extensive damage, or a hard landing
- 13-30. Tolerances for balanced flight control surfaces are specified in what publication?
1. The NATOPS
 2. The NAMP
 3. The IPB
 4. The SRM
- 13-31. What method(s) of aircraft leveling is/are the most accurate?
1. Spirit
 2. Transit
 3. Suspension
 4. Plumb bob and datum plate
- 13-32. For acceptable aerodynamic tolerances, the left- and right-hand wing twist must be within what maximum readings?
1. 1°, 12 min
 2. 2°, 12 min
 3. 3°, 12 min
 4. 0°, 12 min
- 13-33. The word "helicopter" means helical wing, which comes from what language?
1. Greek
 2. French
 3. Hebrew
 4. Italian
- 13-34. Helicopter lift is provided by what means?
1. The engines
 2. The fixed wings
 3. The rotor blades
 4. The fuselage design
- 13-35. Rotor blades that are highly polished will reduce which of the following forces?
1. Lift
 2. Drag
 3. Speed
 4. Velocity
- 13-36. Rotor blade dissymmetry is created by what means?
1. By horizontal flight only
 2. By hovering in a wind condition only
 3. By horizontal flight or hovering in a wind condition
 4. By hovering in a no-wind condition

- 13-37. What method corrects dissymmetry by equalizing lift?
1. Coning
 2. Fluttering
 3. Autorotating
 4. Blade flapping
- 13-38. What type of main rotor allows each of its blades to move vertically and horizontally?
1. A hinged rotor
 2. A horizontal rotor
 3. An adjustable rotor
 4. An articulated rotor
- 13-39. The maximum ground cushion effect is achieved during what condition?
1. 0 knots
 2. 7 knots
 3. 12 knots
 4. 15 knots
- 13-40. What is the most common type of helicopter?
1. Dual main rotor
 2. Single main rotor
 3. Tandem main rotor
 4. Coaxial main rotor
- 13-41. The lateral movement of a helicopter is controlled by which of the following systems?
1. Cyclic only
 2. Collective only
 3. Cyclic and collective only
 4. Cyclic, collective, and rotary rudder
- 13-42. The friction lock on a helicopter's collective stick is used for which of the following purposes?
1. To provide feel when operating the controls only
 2. To prevent the stick from creeping during flight only
 3. To provide feel when operating the controls and to prevent the stick from creeping during flight
 4. To provide a means of locking the main rotor assembly when parking the helicopter in high winds
- 13-43. The negative force gradient spring on a rotary rudder control system is preloaded to what maximum amount of force?
1. 500 lb
 2. 600 lb
 3. 700 lb
 4. 800 lb
- 13-44. What component integrates collective pitch control movements with fore and aft, lateral, and directional movements?
1. The auxiliary servo cylinder
 2. The primary servo cylinder
 3. The rotor servo
 4. The mixing unit
- 13-45. During a power failure, what, if anything, happens to the primary servo cylinders?
1. They are bypassed
 2. They function as control rods
 3. They operate at a reduced rate of speed
 4. Nothing
- 13-46. What component(s) allow(s) the swashplate to tilt off of its horizontal plane and move on its vertical axis?
1. The nutating plate
 2. The universal joint
 3. The ball ring and socket
 4. The constant velocity joint
- 13-47. Which, if any, of the following solvents is authorized for cleaning rotary-wing and rudder blades?
1. Naphtha
 2. Lacquer thinner
 3. Carbon tetrachloride
 4. None of the above
- 13-48. Proper blade tracking prevents which of the following problems?
1. Flexing
 2. Vibration
 3. Overlapping
 4. Dissymmetry of lift
- 13-49. Which of the following types of blade tracking devices can be used in flight or on the ground?
1. Static
 2. Dynamic
 3. Strobex
 4. Hydrostatic
- 13-50. A rotor brake assembly is comparable to which of the following wheel brake assemblies?
1. Single disc
 2. Multiple disc
 3. Segmented rotor
 4. Expandable tube

13-51. What is the minimum pressure required to effectively operate the rotor brake?

1. 320 psi
2. 370 psi
3. 410 psi
4. 450 psi

13-52. When blade folding is performed, what is the condition of (a) the engine and (b) the rotary-wing head?

1. (a) Stopped (b) stopped
2. (a) Stopped (b) operating
3. (a) Operating (b) stopped
4. (a) Operating (b) operating

13-53. What flight control device(s) may have to be moved around the neutral position to engage the control lockpin?

1. The pilot's foot pedals
2. The cyclic control stick
3. The copilot's foot pedals
4. The collective control stick

IN ANSWERING QUESTIONS 13-54 THROUGH 13-57, SELECT FROM COLUMN B THE BLADE FOLDING SYSTEM COMPONENT THAT MATCHES THE FUNCTION LISTED IN COLUMN A.

A. FUNCTION B. COMPONENT

13-54. Prevents pressure from entering the blade fold system during flight

1. Blade fold accumulator

13-55. Transfers fluid to the rotary-wing head for folding

2. Control lock cylinder

13-56. Dampens out pressure surges during the fold and spread cycles

3. Rotor coupling

13-57. Locks the flight controls during the fold cycle

4. Safety valve

13-58. What is the normal time for blade folding?

1. 12 to 15 sec
2. 15 to 21 sec
3. 22 to 37 sec
4. 27 to 41 sec