

*S. Compton, Jr.,*

*Motor.*

*N<sup>o</sup> 331.*

*Patented July 31, 1837.*

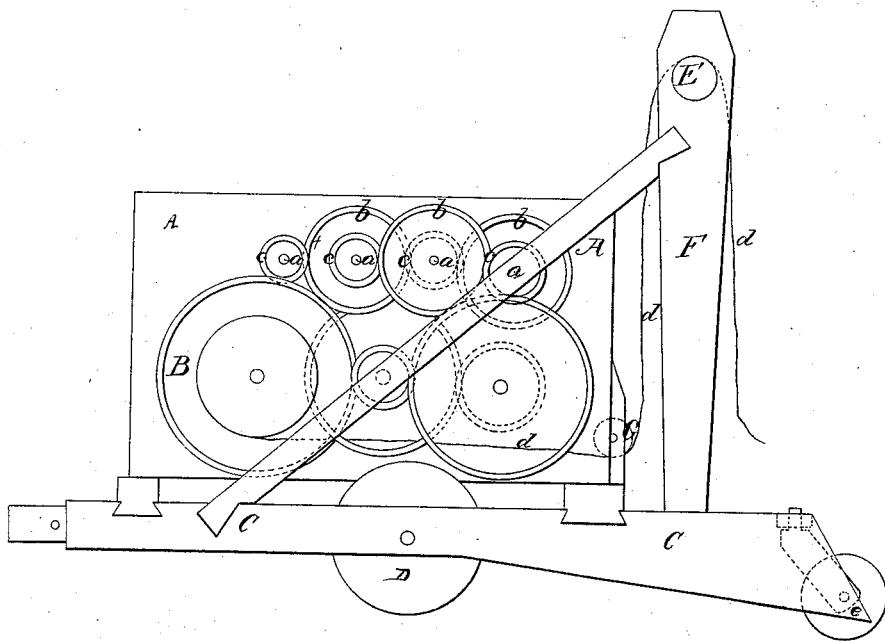
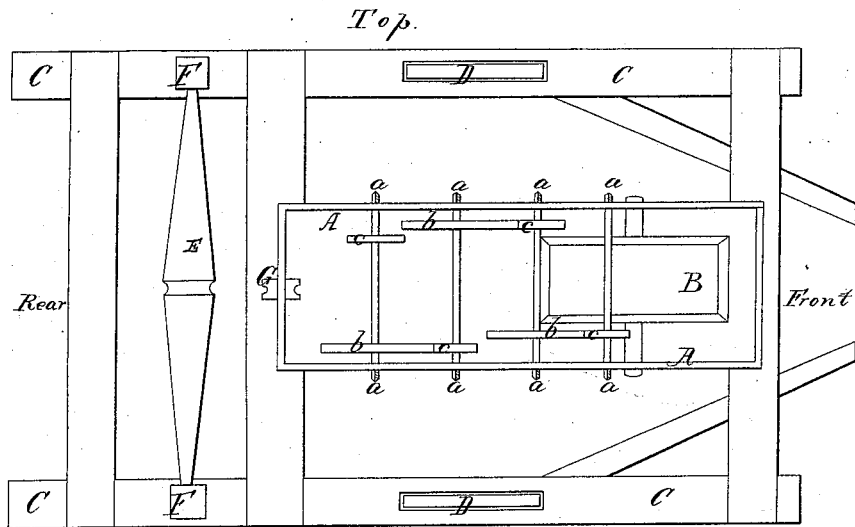

# UNITED STATES PATENT OFFICE.

STEPHEN COMPTON, JR., OF ELMIRA, NEW YORK.

LOCOMOTIVE POWER-MACHINE FOR REMOVING HOUSES, &c.

Specification of Letters Patent No. 331, dated July 31, 1837.

*To all whom it may concern:*

Be it known that I, STEPHEN COMPTON, Jr., of Elmira, in the county of Chemung and State of New York, have invented an Improved Locomotive Power-Machine, which I intend to employ in the removal of houses or other heavy articles and to the overcoming of great resistances, such as to the removal of trees or stumps of trees from the ground; and I do hereby declare that the following is a full and exact description thereof.

In a suitable frame, or box, such as is represented at A, A, in the accompanying drawing, I mount any number of cog-wheels and pinions, which I affix to shafts, the gudgeons of which have their bearings in the frame. The manner of gearing such wheels and pinions, so as to increase the power applied in any desired degree is a thing so well known to machinists as not to require any description.

The ends of the shafts *a, a*, which carry the wheels *b, b*, and pinions *c, c*, project out beyond their bearings, to receive winches, by which the power of men may be applied to any number of them. A drum, B, is used to receive a rope, or chain, which is to be wound upon it by the power applied to the winches. This rope, or chain, is seen passing along from the drum, out from the machine at *d, d*, and is to be attached firmly to the house, or other article, to be removed.

The frame containing the wheel-work is to be mounted upon a strong carriage, placed upon wheels, or trucks, so that the whole may be drawn forward by horses, or other power.

C, C, represents a side of the carriage, and D, one of the wheels. There may be two, or more, wheels, instead of one, on each side, or a third wheel may be placed on the hind rail of the carriage, to aid in its removal when it is to be drawn forward. The rear ends *e, e*, of the side pieces of the carriage are to be armed with iron, and when in use they

are to rest upon the ground, they being so formed, as shown in the drawing, that by the force applied to the drum, they shall be drawn into, and take firm hold thereof, in a degree proportioned to the power.

When the resistance to be overcome requires that it should be acted upon vertically, or in any way which deviates greatly from a horizontal direction, the rope, or chain, may be passed over a roller, E, the gudgeons of which are supported by the uprights F, on the rear end of the carriage, there being a pulley, or roller, G, at the lower part of the frame, to change the direction of the rope, or chain, for the purpose of conducting it over the roller E. A ratchet wheel and pawl are applied on the shaft of the first mover, in the usual way. When this machine is to be used for moving houses, (or for other similar purposes) it is placed at a suitable distance therefrom, the requisite attachments made, and the house drawn as near as may be to it; the power engine is then again removed to a suitable distance, and the operation repeated until the intended purpose is accomplished.

I do not claim to be the inventor of a combination of wheels and pinions for the purpose of increasing and applying power through the intervention of a drum and rope, or chain, this being a well known mode of procedure. But

What I do claim, is

The mounting of such a machine upon a carriage, constructed in the way herein described, so that it may be readily removed from place to place, and that it shall anchor itself, or take firm hold in the ground, by the action of the power applied substantially in the manner herein shown; which machine is to be applied to the removal of houses, or the overcoming of other resistances.

STEPHEN COMPTON, JR.

Witnesses:

THOS. P. JONES,  
CLEMENT T. FOOTE.