

B. H. Brown,
Brick Mold,
N^o 436, Patented Oct. 23, 1837.

Fig: 1.

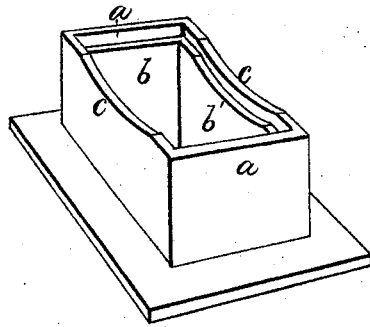
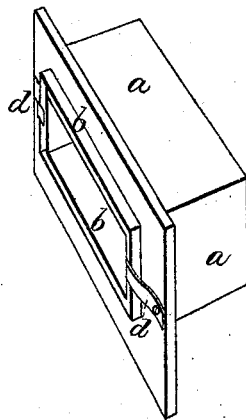

Fig: 2.



UNITED STATES PATENT OFFICE.

BENJAMIN H. BROWN, OF ALEXANDRIA, DISTRICT OF COLUMBIA.

BRICK MOLD USED IN BRICK-PRESSING MACHINES.

Specification of Letters Patent No. 436, dated October 23, 1837.

To all whom it may concern:

Be it known that I, BENJAMIN H. BROWN, of the city of Alexandria, in the District of Columbia, have invented an improvement in the mode of constructing the molds used for pressing brick, which improved mold is intended to be applied in the machine for pressing brick from dry clay for which a patent was granted to Nathan Sawyer on the eighth day of April, 1835, but which may also be employed in other machines for the same purpose; and I do hereby declare that the following is a full and exact description thereof.

The upper edge of the mold is made concave on two sides, as in said Sawyer's machine, for the purpose expressed in his specification thereof; but I make the said mold in two thicknesses, consisting of two boxes, or frames, one fitting within the other, as shown in the accompanying drawing, in which Figure 1 represents the upper, and Fig. 2, the lower side of my compound mold.

a, a is the outer box, or mold, and *b, b*, the inner which latter fits within the former, and slides freely in it. In both figures it is

represented as depressed below the edge of the outer mold, but when not in use the edges coincide, the two boxes being of the same depth. The upper edges *c, c*, it will be seen, are hollowed, as above mentioned. *d, d*, are two springs which bear the inner mold up, and tend to keep it flush with the outer, but which allow it to descend when pressed upon.

In the mold as formerly used, it was extremely difficult to condense the clay as perfectly at the bottom as at the top, the friction against the sides tending to prevent this but by allowing the inner mold to slide, it may to a certain extent, descend within the piston, and thus allow the clay to be condensed on the lower side of the brick.

What I claim as constituting my improvement is—

The above described double mold, consisting of one sliding within the other in the manner, and for the purpose, above set forth.

B. H. BROWN.

Witnesses:

W. THOMPSON,
G. THORN.