

I. Wheeler.

Mower.

N<sup>o</sup> 754

Patented May 30, 1838

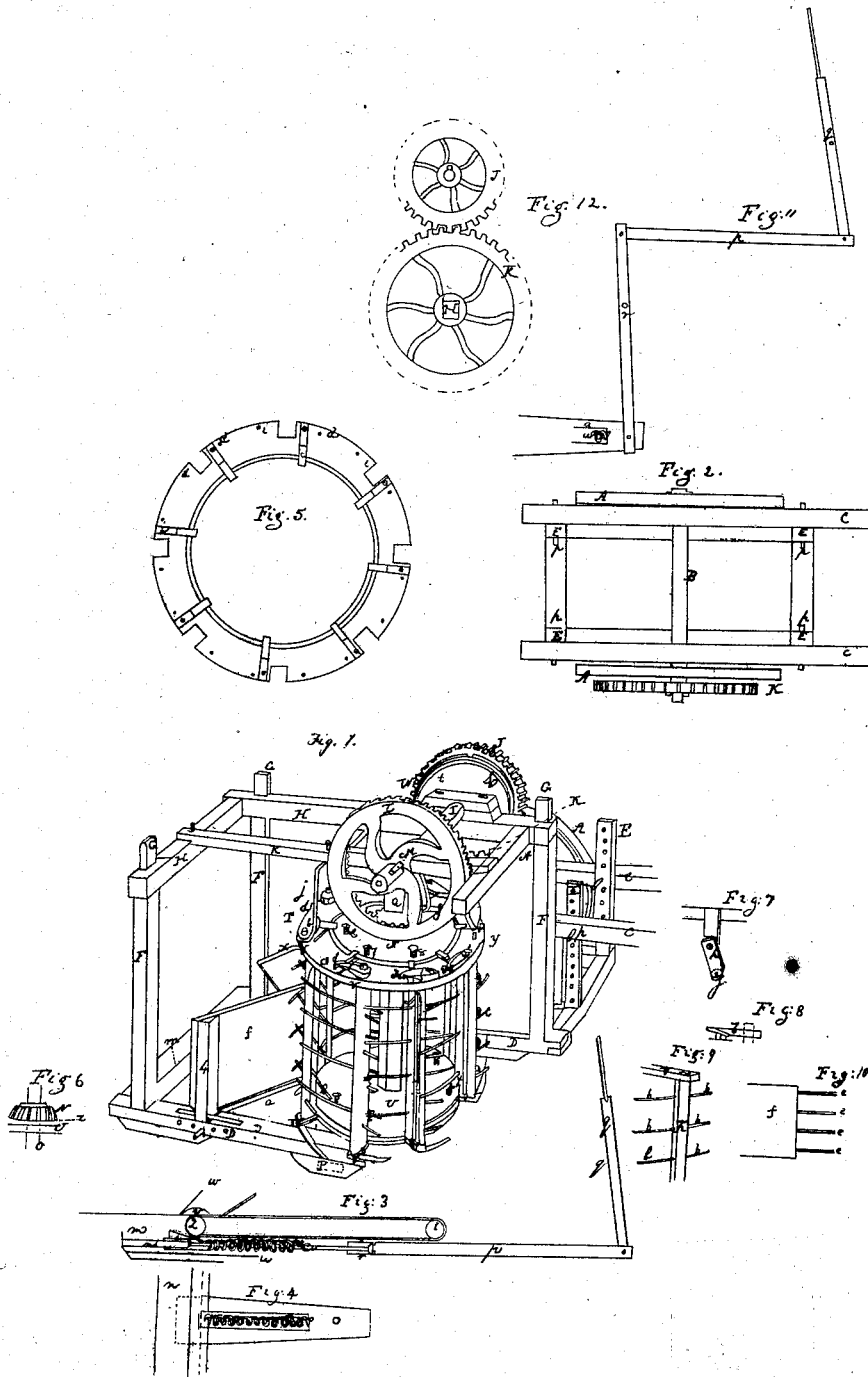

I. Wheeler.

Mower.

N<sup>o</sup> 754

Patented May 30, 1838.

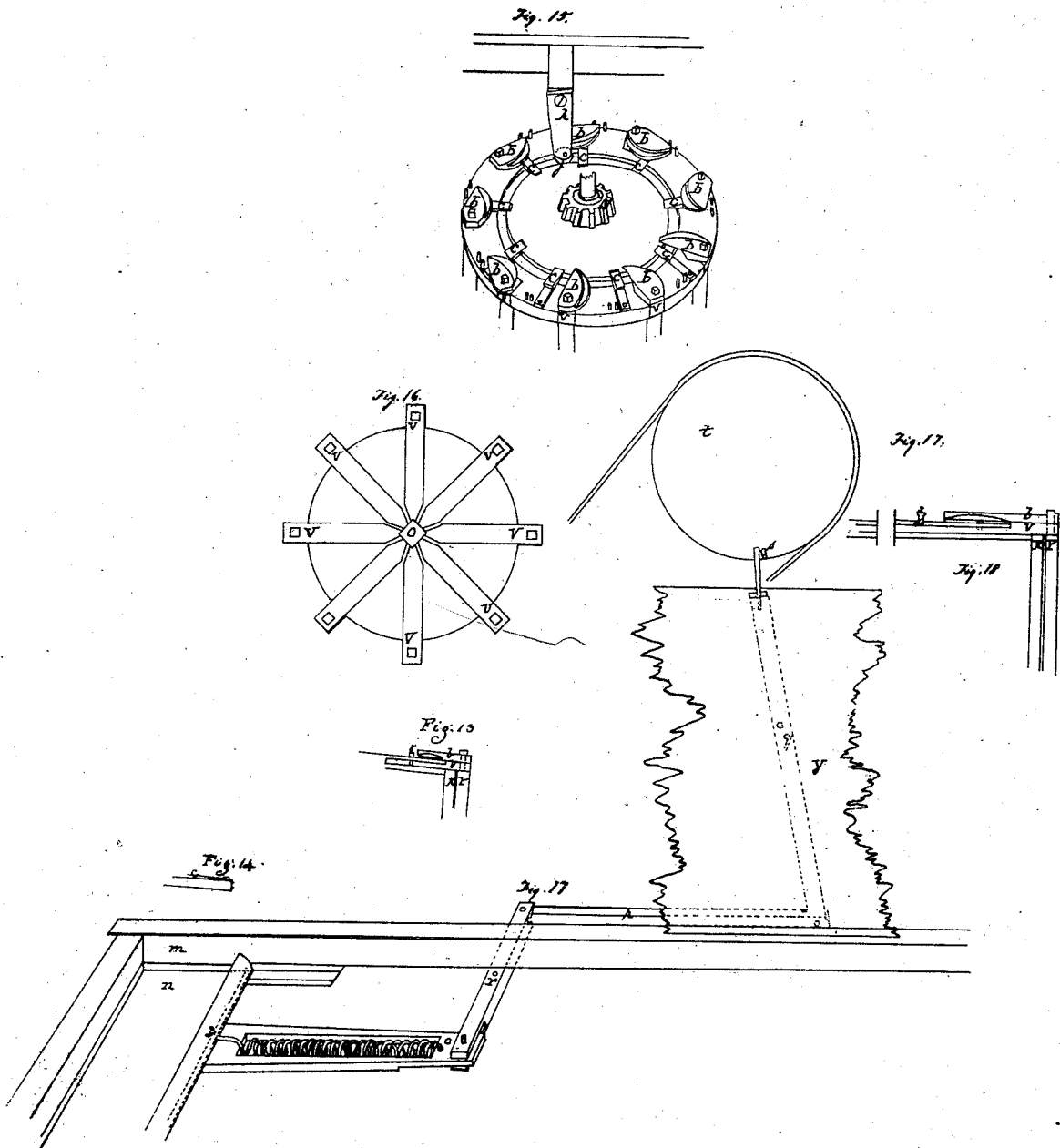

# UNITED STATES PATENT OFFICE.

IRA WHEELER, OF SALEM, NEW HAMPSHIRE.

## IMPROVEMENT IN MACHINES FOR MOWING GRASS, GRAIN, &c.

Specification forming part of Letters Patent No. 754, dated May 30, 1838.

### *To all whom it may concern:*

Be it known that I, IRA WHEELER, of Salem, in the county of Rockingham and State of New Hampshire, have invented a new and useful Machine for Cutting Hay, Grain, &c., called "Wheeler's Mowing and Cradling Machine," which is described as follows, reference being had to the annexed drawings of the same, making part of this specification.

The main feature of this machine consists of a cart (without the body) drawn forward by animal-power, to which, on one side, is suspended a frame containing a horizontally-revolving wheel fixed on a vertical axle armed at the bottom with a number of horizontal scythes for cutting the hay, &c., which, as fast as it is cut, is carried round by fingers and deposited upon a revolving endless apron in the rear of the same, which conveys it off at the end of the frame and lays it in windrows; or, if grain, it is deposited by said apron into a box with a sliding bottom, by which it is dropped in gavels, said frame being raised or lowered, so as to be adapted for the kind of cutting required, by pins inserted through posts of the frame into the shafts.

A, Figures 1, 2, represents the two cart-wheels, fixed permanently on the axle B, Fig. 2, and turning upon the ground, on which axle is fixed the main cog-wheel K, Figs. 2 and 12, for turning the wheel of cutters or scythes. If the cart-wheels should be made to turn on the axle, then the said cog-wheel may be fastened to the face of one of the cart-wheels.

C C are the shafts of the cart, between which the horse is placed for drawing the machine.

D is a rectangular frame for supporting the wheel-gearing, &c., into which are mortised and tenoned four short posts, E, Figs. 1 and 2, by which the frame D is attached to the shafts C by means of a number of holes made in said posts, with corresponding holes in the shafts, into which are inserted pins *pp* for raising or lowering the frame to any point desired and holding it fast. Two of said posts are on one side of the cart and two on the other, the shafts C being on the outside of them. F F F, three long posts, mortised and tenoned at their lower ends into the frame D, having long tenons G on their upper ends, over which moves another frame, H, supporting the horizontal axle I of the gearing, &c., the long tenons moving loosely in mortises in said upper frame, so

that the lower frame and posts, with the moving wheel, may be raised or lowered without disturbing the upper frame and gearing from a horizontal position. Across the top frame lies the horizontal axle I, on which is fixed a small cog-wheel, J, working into the main cog-wheel K, Fig. 12. A vertical bevel-wheel, L, is also put on this shaft, movable longitudinally on said axle, but prevented from turning on it by a tongue, M, on the shaft fitting into a groove in the bevel-wheel. This vertical bevel-wheel L works into a horizontal bevel-wheel, N, Figs. 1 and 6, on the vertical shaft O of the mowing-wheel, Fig. 1, which is stepped into a box on a cross-piece, P, of the frame, the upper end of said shaft turning in a round aperture in a block, Q, hung from the under side of a cross-bar, R, which may be moved to the right or left, as required, in case the diameter of the mowing-wheel is to be increased or diminished, said cross-bar being secured at the place desired by screws or bolts S. The last-mentioned bevel-wheel, N, may be raised or lowered on the vertical shaft O by washers or pins *z*, Fig. 6, when it is required to raise or lower the mowing-wheel and at the same time keep the bevel-wheels in gear, said horizontal bevel-wheel being prevented from turning on the axle in the same manner as before described with the horizontal axle—that is, by a tongue and groove.

On the vertical shaft is constructed the mowing-wheel T. This consists of two circular heads, U U, fixed permanently on said shaft, one near the top and the other near the bottom. In these heads are made grooves radiating from the center, in which are placed arms V, Figs. 1, 15, 16, drawn out or pushed in and secured at any point desired, according to the diameter of the circle required for the sweep of the scythes, by screws or pins 6 7 8, Figs. 1 and 13. To the outer ends of the lower arms are fastened the scythes or cutters, and at a proper pitch, according to the kind of grass or grain to be cut. Between these arms, and near the outer ends thereof, are placed vertical rollers Y, turning on pivots, into which are inserted fingers for gathering the grass or grain and laying it upon the revolving apron *a*. The upper gudgeons of said rollers pass through the upper arms far enough to receive curved levers *b*, Figs. 1, 8, 13, and 18, beveled on the under side in order to allow them to pass over

spring-catches *c'*, fastened to the upper head of the wheel, or to the upper arms. These spring-catches are for the purpose of holding the fingers in the rollers in the direction of the scythes by means of the curved levers *b*, resting against stops *d*, while conveying the hay round to the revolving apron *a*, and when they arrive with the hay at the revolving apron the hay is met by a set of fingers, *e*, projecting from the end of an inclined board, *f*, Figs. 1 and 10, and received by them from the fingers of the rollers, which are at that moment thrown back by the impediment caused by the hay lodging against said fingers *e*, the spring-catches *c* being pressed down at the same time by coming in contact with a wheel, *g*, Figs. 1 and 7, in the end of an arm, *h*, projecting down from the top frame, which allows the levers to slide over said catches and turn around against stops *i* in the head, which arrests them until they arrive at another arm, *j*, projecting down from the top frame, against which they come in contact and are turned back to their first-described position against the stops in the head. Behind each roller is a vertical bar, *k*, mortised and tenoned into the arms, from which extend fingers *l* on either side to prevent the grass or grain passing into the center of the mowing-wheel. (See also Fig. 9.)

The first roller, No. 1, Fig. 3, conveying the revolving apron *a*, is placed under the edge of the mowing-wheel, and the second, No. 2, revolves parallel to it, in the rear thereof, at a convenient distance therefrom. The gudgeons of these rollers turn in the side pieces of the frame. The endless apron *a* is passed around the rollers in the manner of all such aprons. Under the last-mentioned roller is constructed a box, *m*, with a sliding bottom, *n*, Figs. 1 and 3, for receiving the grain from the endless apron. This sliding bottom is drawn from under the box by a combination of levers, *o p q r*, Fig. 11, operated by a pin, *s*, Fig. 1, in the face of a pulley, *t*, on the horizontal shaft, and is drawn back by a spiral spring, *u*, Figs. 3, 4, and 11, attached to the sliding bottom and the lower side of the box, the fulcrum being at *q* and *r*. (See also Fig. 17.)

The endless apron *a* is turned by means of a pulley, *d*, Fig. 3, on one of its ends, and a band, *w*, passing around it and leading to the pulley just mentioned on the horizontal axle. (See Figs. 1, 3, and 17.)

The grass or grain is directed onto the revolving apron from the mowing-wheel by means of the before-mentioned inclined board or guide, *f*, and fingers in the end thereof, said board being fastened at one end to a post, 4, mortised and tenoned into the frame *D*, which post is movable, in order to set the board as desired. Parallel with said inclined board is another inclined board, *x*, secured to the boarding or sheathing *y*, between the cart-wheels and mowing-wheel.

Fig. 5 represents a circular rim, to be placed upon the upper head when the diameter of the mowing-wheel is to be increased.

Operation: The horse moves forward and draws the machine after him, and the cart-wheels being fixed upon the axle, the latter is caused to turn with them, which also turns the main cog-wheel fixed on it, and this cog-wheel turns the cog-wheel fixed on the end of the horizontal axle which turns the vertical bevel-wheel thereon, and this turns the horizontal bevel-wheel on the mowing-wheel axle, which turns said mowing-wheel horizontally. This cuts the grass or grain by means of the scythes at the ends of the lower radiating arms. The fingers in the rollers receive the grass or grain, and carry it round somewhat in the manner of a cradle and deliver it against the fingers in the end of the inclined guiding-board. The fingers in the rollers at the same time turn back by the impediment created by the hay, thus lodging against said fingers of the inclined board, the spring-catches being pressed down by the roller as the mowing-wheel revolves, so as to disengage them from the curved levers on the ends of the rollers. Then as the mowing-wheel continues to revolve, said levers come in contact with the other arm, and are thrown back to their proper positions for again receiving another cut of grass or grain, which is delivered, as before, against the fingers of the inclined board, from whence it falls upon the revolving apron, which delivers it into the box with the sliding bottom, which at every revolution of the pulley is drawn from under said box, and drops the grain or grass in windrows or gavels by means of the pin in said pulley moving the combination of levers attached to said sliding bottom, the spring drawing it instantly back to its former position under the box as the pin leaves the levers, the revolving apron being turned by a band passing around said pulley and another pulley on the end of one of the rollers. When it is required to lower the mowing-wheel, so as to cause it to cut nearer to the ground, the pins are drawn from the holes in the short post of the frame and shafts of the cart and inserted into other holes in said posts, and into the same holes of the shafts, which drops the lower frame and mowing-wheel, the upper frame and gearing remaining in the original position, the tenons on the long posts dropping in the mortises in the upper frame, while the horizontal bevel-wheel is slipped up on the vertical shaft and retained in gear with the vertical bevel-wheel by means of washers or pins. The upper end of the vertical shaft also drops down, but its end does not leave the block in which it turns. When it is required to increase the diameter of the circle in which the cutters are to move, the radiating arms may be drawn or extended from the center and secured by screws or pins 6 7 8, and another circular rim with spring-catches, *c*, such as that represented at Fig. 5, put on the top of the upper arms; or the spring-catches may be secured to the upper radiating arms and be drawn out with them, the position of the bevel-wheels being also changed, if

necessary, by slipping on their respective shafts; and when the position of the vertical shaft of the mowing-wheel is required to be changed, the position of the block Q, in which its upper gudgeon turns, must also be changed by shifting the position of the bar to which said block is fastened, and securing said bar by screws in any position desired, as herein set forth.

The invention claimed and desired to be secured by Letters Patent consists in—

The before-described construction of the wheel for cutting grass, grain, and other arti-

cles, and depositing the same upon a revolving apron which lays it in windrows or gavels, in combination with the inclined boards and fingers, box with sliding bottom and levers, and spring for drawing it out and in, as herein set forth, and it is to be understood that the parts separately are not claimed, but only their combination, and in the wheel the heads and vertical axle are not claimed at all.

IRA WHEELER.

Witnesses:

WM. P. ELLIOT,  
W. BISHOP.