

T. G. OWEN.
Car Coupling.

No. 1,666.

Patented July 1, 1840.

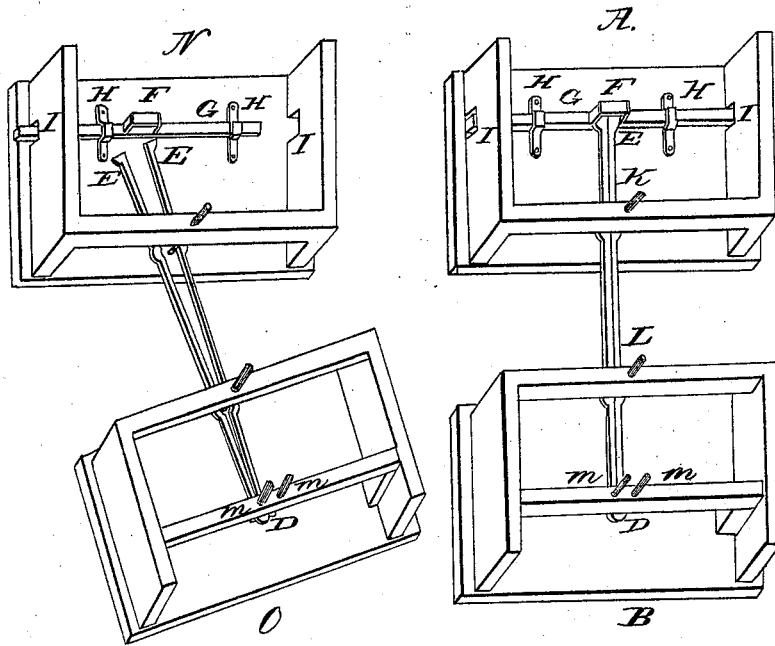

UNITED STATES PATENT OFFICE.

THOMAS G. OWEN, OF BALTIMORE, MARYLAND.

COUPLING-IRON FOR RAILROAD AND OTHER CARRIAGES.

Specification of Letters Patent No. 1,666, dated July 1, 1840.

To all whom it may concern:

Be it known that I, THOMAS G. OWEN, of Baltimore city and State of Maryland, have invented a new and Improved Mode of Preventing Railroad-Cars from Running off the Track or Road; and I do hereby declare that the following is a full and exact description.

The nature of my invention consists of a coupling iron by which the motive power is connected with the car which is so formed that should the engine or preceding car run off the track the following one cannot, because the coupling iron immediately detaches itself from the car in the rear.

To enable others skilled in such matters to make and use my invention I will proceed to describe its construction, operation and application.

This I accompany with a plate or drawing to which I refer.

The letter A represents the platform at the end of the car, the letter B the platform at the end of the engine or tender.

The piece C represents the self detaching coupling iron formed of two pieces joined together at one end by a hinge. When the two pieces are folded together by means of that joint they appear like one piece by which the two cars A and B are coupled together by means of their bolts in the usual way as K and L in the drawings of the respective cars and which bolts going through the bottom of the car are inserted in the coupling iron through holes which are punched or drilled in said iron in such a manner as to present the appearance and answer the purpose of a coupling iron composed of one piece only. So long as the ends of the coupling iron are held together in the staple F and not suffered to escape therefrom by an undue inclination of the preceding car from a right line except so far as may be required to suit the curves of the road, to all of which it is adapted, and adapted too in such proportion as to continue the draft without interruption so long as the preceding car does not leave the track. On each side of the coupling iron at K and L there is a protuberance of such dimensions as to secure an equal degree of strength in that part of the coupling iron which is perforated as at K and L for the reception of the coupling bolts as to the space between them or any other part of the coupling iron when in use, so that the weight necessarily

required to drag forward the hinder car or cars cannot alternate one part of the iron more than the other the longitudinal bearing of the coupling iron has a tendency to cause the two sides of the coupling iron to embrace and cleave closer to the coupling bolts than otherwise.

To recite further the coupling iron C is formed after the manner of a carpenter's rule consisting as before stated of two pieces connected at one end by a joint or hinge as at D in the drawing. The other end of the coupling iron is formed on the outside of each line at the open end a semicircle to leave it at liberty to play with ease in the staple, as at E in the drawing. The two loose ends of the coupling iron are then inserted into a staple F in the drawing, made fast in the center of a sliding bar and made fast to said bar and forming part of the same which moves at right angles as represented in the drawing by the letter G, and which traverses the bottom of the platform of the car from side to side through the two loops H, H, in the drawing, and by which loops or staples the sliding bar is made fast to the car by bolts or otherwise, the loops to be of such dimensions as to keep the bar properly in its place and at the same time be at liberty to slide freely in the loops when the car is in motion when operated upon by any pressure from the coupling iron upon the sides of the staple F, which as before said is attached to and is part of the sliding bar.

The sides of the car as at I, I, in the drawing are perforated to permit the sliding bar to protrude on each side of the car as the action or pressure at F may occasion. Thus when by the coupling iron the cars are attached by means of the bolts K and L and the ends of the coupling iron inserted in the staple at F, so long as the staple F preserves a center or near it, it holds the ends of the coupling iron firmly together and the draft is as accurate and strong as it can be by any mode heretofore in use, but as soon as the leading car inclines to the right or left a corresponding action is produced upon the staple F and of course upon the sliding bar G and as the coupling iron revolves when this inclination takes place upon the bolt at L it slides the bar endwise which causes the coupling iron to describe a segment of a circle until the ends of the coupling iron have moved the staple F from

the center toward one of the sides so far as to allow the end of the coupling iron to escape from the staple F and of course opens. It will then with the least possible
5 action draw the coupling iron off from the bolt K, which it had previously inclosed when held together at the end and the advance car goes its own road taking with it the coupling iron entirely detached from
10 the succeeding one. There are also two steady bolts M M in the drawing which are inserted in the platform of the engine or tender one on each side of the joint end of the coupling iron when in use on the road to
15 cause the action to be more quick in its detaching in case the preceding car, engine or tender should leave the track as there is only one center to move on when one end of the iron is made fast by means of the
20 steady bolts, but when they are out of their place the cars will turn a more acute curve as there is then a center in each coupling bolt K and L on which to turn as a radius. By this means the engineer is enabled to

judge when he should take out the steady 25 bolts or keep them in their place. To conclude the drawing A and B represents two cars attached together by the coupling iron and being drawn in or near a straight line when they cannot be detached. The draw- 30 ing N, O represents two cars that have been detached, the car O running off the track has caused the operation before described, the coupling iron has detached itself, opened and escaped from the bolt and 35 car.

What I claim as my invention and desire to secure by Letters Patent is—

The method of coupling railroad cars or carriages, etc., by means of the double cou- 40 pling irons in combination with the sliding bar for the purpose and in the manner substantially as herein described.

THOMAS G. OWEN.

Witnesses:

JAMES BLAIR,
BENJ. GAITHER.