

C. Carter,
Mortising Machine,

No. 6,458,

Patented May 22, 1849.

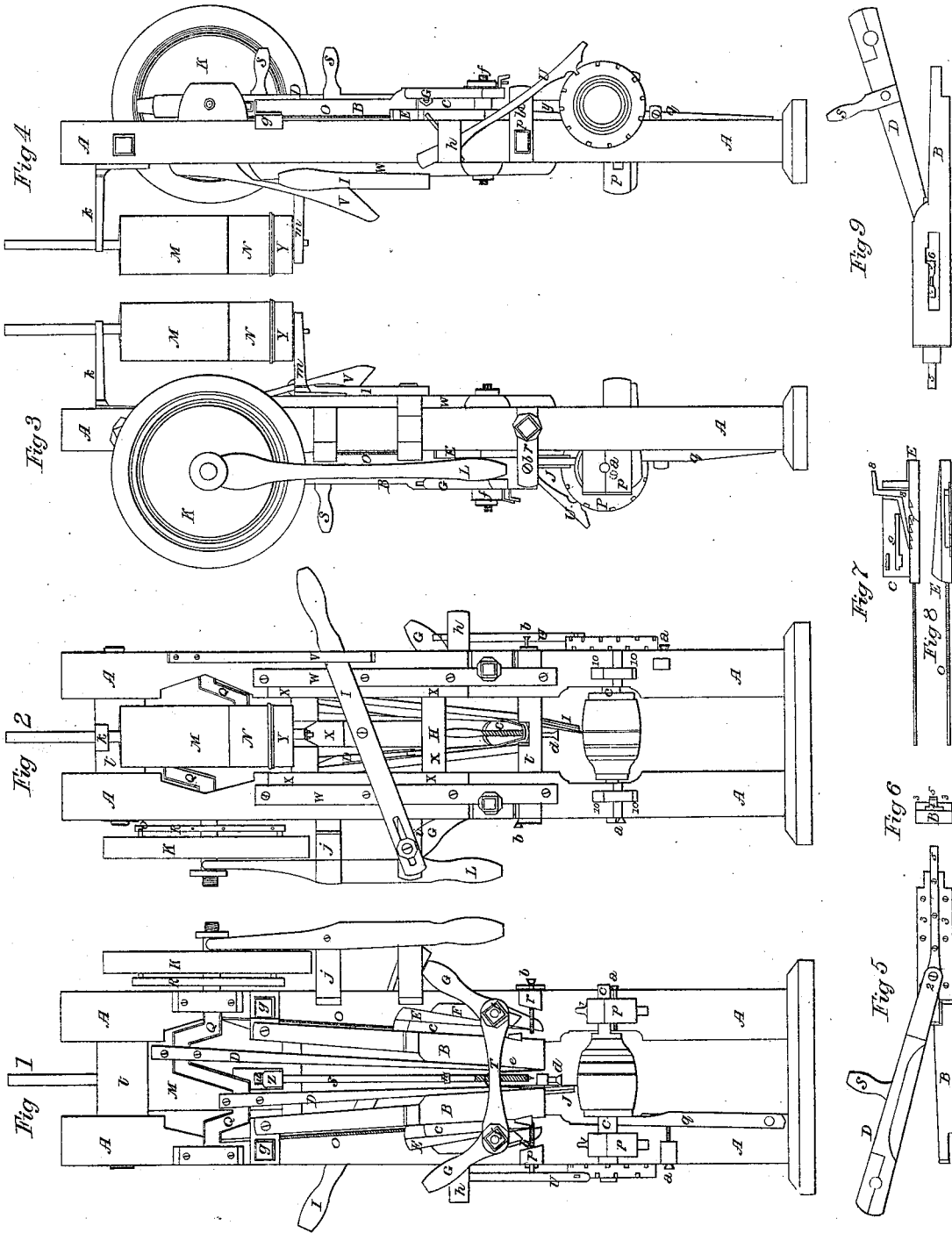

UNITED STATES PATENT OFFICE.

CHANDLER CARTER, OF MANCHESTER, MICHIGAN.

BORING AND MORTISING MACHINE.

Specification of Letters Patent No. 6,458, dated May 22, 1849.

To all whom it may concern:

Be it known that I, CHANDLER CARTER, of Manchester, in the county of Washtenaw and State of Michigan, have invented a new and useful machine for boring and mortising hubs for wagons and all kinds of wheel-carriages, the principle being applicable, with slight variations of construction, to various kinds of mortising; and I do hereby declare that the following is a full, clear, and exact description of the construction and operation of the same, reference being had to the annexed drawings, making a part of this specification, in which—

Figure 1 is a front view of the machine, Fig. 2 a rear view, Figs. 3 and 4 side views, and Figs. 5, 6, 7, 8, and 9 are views of detached portions and sections of the machine.

The several parts of the machine are lettered and numbered as follows, in the drawing—the like parts in all the figures, so far as shown, being designated by the same characters.

A, main posts; B, fenders; C, slides; D, pitmen; E, wedges; F, stoppers; G, levers; H, lower crosspiece to auger gate; I, lever to auger gate; J, chisel stock; K, driving pulley to chisels; L, lever to pulley; M, solid or fast pulley; N, idle pulley; O, rods and springs; P, index; Q, crank or shaft; R, cross-arm on shaft; S, auger shaft; T, cross bar; U, spring to index; V, spring to lever; W, cleats to auger gate; X, auger gate; Y, driving pulley to auger; Z, pulley on auger shaft; *a*, hand screws to regulate hub; *b*, hand screws to regulate fenders; *c*, mandrel; *d*, hand screw; *e*, auger; *f*, bolts to confine crossbar, &c.; *g*, blocks and bolts; *h*, *i*, *j*, *k*, *m*, *n*, stands; *p*, bearers to support mandrel; *q*, lever; *r*, stands; *s*, handles to pitmen; *t*, girths; 1, hand screws to caps; 2, joint to pitmen; 3, cleats on fenders; 4, chisel stock; 5, chisel; 6, groove in fenders; 7, ragiron; 8, spring with catch; 9, long groove in slides; 10, keys to bearers.

The ground work upon which the machine is built consists of two upright parts marked A in the drawings which are 8½ feet high and seven inches wide by 4 in. thick. These are connected by a sill at the foot and by two girths, one of which is about 3 feet from the foot and in size 3 by 4 in.—the other is near the head of the machine and is 5 by 4 in. in size. The girths are marked *t* Figs. 1 and 2—they are ten inches long,—making

the frame two feet wide. The frame is strongly bound together by bolts which pass through the posts and girths and confined by nuts.

The two fenders B, B, Fig. 1 are three feet four inches long,—3 in. thick and 4 in. wide at the lower end for about 20 in.—the remaining distance may be reduced to 2 in.—as seen in Fig. 5. These fenders at their upper end are halved on to, and suspended from blocks which are let into the posts cross wise in grooves ½ in. deep—the blocks being confined to the posts by bolts with nuts as seen at *g*, *g*, Fig. 1. The mortise through the blocks *g*, *g*, through which the bolts pass, is oblong, which permits the blocks to be moved a short distance in or out, in order to give any desired angle to the mortise to be made by the adjustment of the fenders.

On the inside of the lower or broad part of the fenders, are fixed cleats, which are rabbeted on their under side to form guides for the chisel stocks. The chisel stocks are 16 in. long, 1½ in. thick by 1¾ in. wide. They are rabbeted on the edges so as to fit the guide formed by the cleats on the fenders.

Fig. 6 shows an end view of a section of the fender B, the cleats 3, 3, and chisel stock 4 with the chisel on its edge at 5. The chisels are about 18 in. long—made of ¾ in. square iron with steel bits and are fastened with screws to the chisel stocks—the chisel must project about 6 in. below the stock. The chisels are operated by pitmen D, D, which are connected to the chisels by a rule joint. The joint may be formed by riveting plates of iron to both sides of the pitmen, between the ends of the plates the chisel may pass and be made fast by a bolt. Fig. 5 shows an inside view of fender B, pitman D, chisel 5, and cleats 3, 3, with the joint connecting the chisel to the pitman at 2. If preferred the chisel stock may be made of cast iron and connected by a joint to the pitmen, in which case a dove tail groove may be formed in the lower end of the stock and a chisel bit of the proper dimensions fitted to it and fastened by a key or pin.

The pitmen are attached to the crank or shaft Q by caps and bolts. The crank is supported by bearings bolted to the front of the posts—it is a double angular crank with the bearings for the pitmen 4½ in. from the center of motion, giving a sweep to the pitmen of 9 in. The pitmen are attached to

bearings on the opposite angles of the crank by which an alternate motion is produced in the chisels.

The stoppers F F are oblong pieces 20 inches in length $2\frac{1}{2}$ inches wide and $1\frac{1}{4}$ inches thick, lying against the posts and confined by, and move on the bolts *f* which support the cross bar T. Next to the stoppers and also lying against the posts are the wedges E E which are 18 inches long, $1\frac{1}{4}$ inches thick, 1 inch wide at the lower end and 3 inches at the upper end. They are rabbeted on their front inside edge $\frac{1}{4}$ inch deep to admit and partly sustain in place the slides C. To the upper end of the wedges are fastened the rods and springs O O. The rods pass up and move freely through the blocks from which the fenders are suspended. The springs are steel wire coiled around the rods. They serve to keep the wedges down to their places; also they keep the wedges from being forced too high by the action of the chisels, as shown hereafter. On the inner edge of the wedges rag-irons are fixed with the teeth pointing to the front.

Fig. 8 shows a front view of the wedge E, rod and spring O and rag-iron *r* on the edge of the wedge. The slides C C are 18 inches long, 1 inch thick and 3 inches wide. They are placed edgewise on the rabbeting of the wedges, as seen in Fig. 7, which shows an inside view of wedge E, slide C and rod O. To the inside of the slide C, Fig. 7, is fixed a spring 8 with a catch which takes into the rag iron on the wedge. The spring 8 passes to the front in a groove in the slide and has a thumb piece by which the catch on the spring is raised from the rag iron when necessary. The slides C C are confined to the fenders B B, Fig. 1, by hand screws which pass through the slides in an oblong mortise so as to allow the slides to move about three-quarters of an inch up and down. They have a long groove on their inside (9, Fig. 7) in which a cog plays to give them motion. This cog is fastened to and moves with the chisel stock and is sufficiently long to pass through the fenders into the groove in the slide. The long groove in fender, also the end of the long cog is seen at 6, Fig. 9.

The lower end of the fenders B B lie against the slides C C and the edge of the wedges E E, and are kept in place by the middle girth *t*, Fig. 2, at the back and by the cross bar T, Fig. 1, in front. The fenders are kept firmly against the wedges laterally by two steel springs which are fixed to and between the fenders at their lower ends, one spring on each side of the chisel. The spring in front of the chisel is seen in Fig. 1 just back of the cross bar T with its curved end up; the other spring from its position cannot be shown in the drawing; it is placed horizontally above the middle girth. The

levers G G are of any convenient length, 1 inch thick and move upon the bolt *f* as a fulcrum. A band or washer is placed upon the bolts *f f* between the stoppers F F and the levers G G so as to bring the levers in front next to the cross bar T and keep both levers and stoppers in their places. The object of the levers is to throw the chisels together by acting against the fenders. On the back of the posts A A is placed the auger gate X, Fig. 2, which is made of stuff 1 inch thick and two feet long. It is framed together with two cross pieces and one center perpendicular piece to which the stands are fixed. The auger gate moves in grooves formed by cleats W W, Fig. 2, fixed to the back of the posts A. The auger shaft S, Fig. 1, is supported by, and moves in bearings in stands which are fixed to the center piece of the auger gate.

The front ends of these stands are seen at *n n*, Fig. 1, the stands being of such length as to bring the auger shaft in front in line with the chisels. The lower end of the auger shaft terminates in a screw, the auger *e*, Figs. 1 and 2, has a corresponding socket and is screwed on to the shaft. Near the upper end of the auger shaft is the pulley Z, Fig. 1, around which a belt passes to drive the auger. The auger gate is raised and lowered by means of the lever I which is fast to the stand *i*, Figs. 1 and 2, and is connected to the auger gate at its center. The lever is moved by hand. When raised, the spring V keeps it in place. To the back of the auger gate is fixed the stand in Figs. 3 and 4 which supports the pulleys Y N M. The upper part of the pulley shaft is prolonged above the stand *k* which is fixed to the upper girth of the machine. The pulley Y is directly back of the pulley Z on the auger shaft and the two are connected by a belt.

The pulley N is idle. Around this a belt passes backward between friction guides to the power used in driving the machine. The pulley M is fast, and when by the action of the lever I the auger gate is lowered, this pulley M is brought into the position before occupied by the pulley N, when the belt from the power takes effect and puts it in motion together with the auger, by the connection of the pulleys Z¹ and Y. The auger gate is prevented from descending too low by the hand screw *d*, Fig. 1, which passes up through the middle girth and against which the lower stand of the auger shaft strikes, on the descent of the auger gate. The pulley Z cannot be above 3 inches in diameter without interfering with the fenders. The pulley Y should be of such comparative size as to give proper velocity to the auger.

On the crank Q which projects to the right for that purpose is keyed the cross arm R. On the outside of the cross arm

70

75

80

85

90

95

100

105

110

115

120

125

130

and moving freely on the same axle is the driving pulley K which has two pins or cogs on the face next the cross arm. These cogs on the revolution of the pulley catch on the cross arm and communicate motion to the crank and pitmen. The pulley K is thrown off so as to relieve the cogs from the cross arm R by means of the lever L. The pulley K receives its motion by connection with the power.

The hub to be mortised is first bored, reamed, and turned and placed upon the mandrel *c* Fig. 1—the mandrel is placed upon the bearers *p* and secured by the caps and hand screws *l* Fig. 1. The bearers *p*, *p*, Fig. 1 are pieces which pass through the posts A, A, and are secured by keys at the back of the posts—they are also keyed above and below (see 10, 10, Fig. 2) so that by regulating these keys the mandrel may be brought to the exact stroke of the chisels. On the left of the mandrel *c* is the index P which has as many sockets at equal distances on its circumference as there are mortises required in the hub. The spring cog U which fits into the sockets of the index P serves to keep the mandrel in position for the several mortises. The hub is kept in place endwise by the hand screws *a* *a* one of which acts directly against the hub—the other acts upon the lever of which presses the hub. The position of the mandrel and the descent of the auger and chisels must be so calculated that the auger and chisels will cut through the upper part of the hub to the mandrel without cutting the mandrel. The width of the mortise is regulated by the width of the chisels—the length, by the extension of the chisels laterally. The lateral extension of the chisels is regulated by the hand screws *b*, *b*, Fig. 1 against which the fenders strike. The stands *h*, *i*, *j*, are framed or otherwise fastened to the posts A, A. The stands *r*, *r*, are let into the posts and confined by the bolts which binds the frame together.

To put the machine in operation, it must be firmly fixed in the position it is intended to occupy and the pulleys K and N connected by belts or otherwise with the power that is to drive the machine. A hub is then placed upon the mandrel *c*—the mandrel placed in the bearers *p* and the caps secured by the hand screws *l*. The fenders must be extended against the hand screws *b*, *b*, in order to give room for the auger. The hub is then adjusted by the hand screws *a*, *a*, so that the auger will act in the center of the mortise to be made. The lever I is then depressed which brings down the auger gate—by which the auger is brought in contact with the hub at the same time that the fast pulley M is brought into the position before occupied by N, when the belt

from the power takes effect and puts the auger in motion. When the hole is bored the lever I is raised which removes the auger out of the way of the chisels and at the same time the driving belt passes on to the idle pulley N and the motion of the auger ceases. The spring V retains the lever I in its place. The fenders B, B, are then thrown together by the levers G, G, so that the chisels will strike into the hole made by the auger,—at the same time the spring-catches on the slide (see 8 Fig. 7) are raised by means of their thumb pieces, when the spiral springs O, O, force the wedges down behind the fenders and keep them in place. The pulley K is then thrown against the cross arm R by means of the lever L, the cogs on the face of the pulley catch on the cross arm and set crank Q pitmen D, D, and chisels in motion.

On the rise of each chisel the long cog on the chisel stock strikes the slide C, at the upper end of the groove (9 Fig. 7), and raises it about $\frac{3}{4}$ of an inch (the slide C being confined to the fender by a hand screw on a mortise with $\frac{3}{4}$ of an inch play, it can be raised no higher), the slide by means of the catch 8 Fig. 7 acting upon the rag-iron 7 Fig. 7 raises the wedge the same distance. By thus raising the wedges the fenders are relieved and the springs between the fenders force the fenders apart so that on the next descent of the chisels they strike back the distance desired for the thickness of a chip. On the descent of the chisels the long cog strikes the slide at the lower end of the groove 9 Fig. 7 and forces it down a short distance by which the spring catch 8 Fig. 7 catches into another tooth of the rag iron, when, on the next ascent of the chisel the wedge is again raised and the fenders allowed to be forced apart by the springs between them. This is continued until the fenders are stopped by the hand screws *b*, *b*, and the mortise is finished. The motion of the chisels is then stopped by throwing the pulley K from the cross arm R by the use of the lever L'. If one of the chisels should remain in the mortise it may be raised by means of the handles *s* *s* Figs. 3 and 4 to the pitmen. The spring cog U is then raised and the index P turned forward one notch when the hub is in position for another mortise. The same process with the auger and chisels is then repeated until the hub is finished. The thickness of the chip cut at each stroke of the chisels will depend upon the obliquity of the wedges and the distance between the teeth of the rag iron 7 Fig. 7; with a wedge increasing 2 in. in twenty, raised $\frac{3}{4}$ in. at each stroke as in this machine the chip will be about $\frac{1}{16}$ in. in thickness. The mandrel should fit the hub exactly and all parts of

the machine should be nicely fitted to their places, otherwise too much jarring would occur.

By the use of this machine a set of four wagon hubs may be mortised in twenty minutes and in a most perfect manner. The several parts of the machine may be made of either wood or iron and it may be enlarged or reduced in size to suit the kind of work to be done or to meet the views of the constructor.

What I claim as my invention and desire to secure by Letters Patent, is—

The combination of an auger and two chisels with the several parts which regulate their operation for the purpose of boring and mortising hubs, as the method

by which the auger is brought to use through the auger gate X Fig. 2, the stands n , n , m , and k with the arrangement of the pulleys Z, Y, N, and M,—the operation and government of two chisels through the use of fenders B, B,—long cog on chisel stock (see 6 Fig. 9), slides C, C, and spring-catch 8, Fig. 7, wedges E, E, and rag-iron 7 Fig. 7, rods and springs O, O, stoppers F, F, and springs which throw the fenders apart laterally, the combination being more particularly described in the foregoing specifications.

CHANDLER CARTER.

Witnesses:

ALANSON CASE,
JOHN KEYES.