

E. H. Ashcroft,
Oil Pump.

No. 45,573,

Patented Dec. 27, 1864.

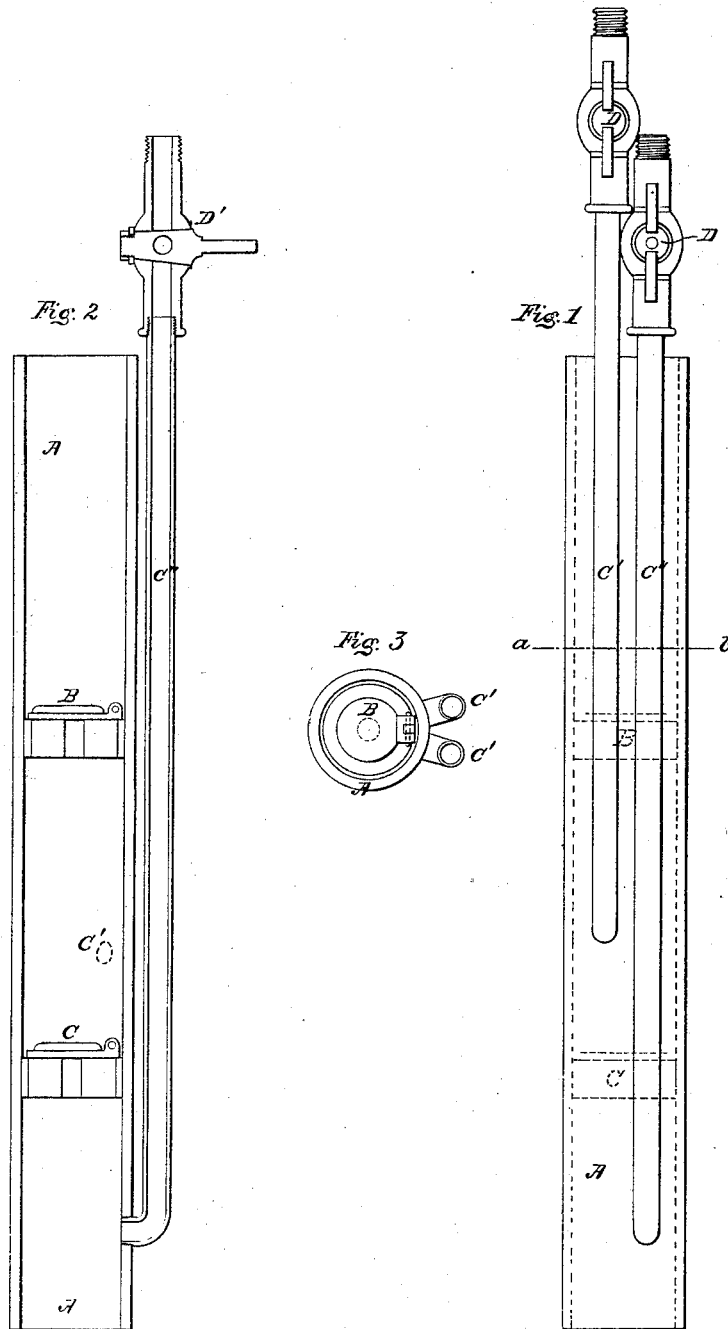

Witnesses
John S. Hollingshead
John D. Bloor

Inventor
E. H. Ashcroft

UNITED STATES PATENT OFFICE.

EDWARD H. ASHCROFT, OF LYNN, MASSACHUSETTS.

IMPROVEMENT IN OIL-WELL PUMPS.

Specification forming part of Letters Patent No. 45,573, dated December 27, 1864.

To all whom it may concern:

Be it known that I, EDWARD H. ASHCROFT, of Lynn, in the county of Essex and State of Massachusetts, have invented a new and Improved Method of Relieving Oil-Well Pump-Valves; and I do hereby declare that the following is a full and exact description thereof, reference being had to the accompanying drawings, and to the letters of reference marked thereon.

In many instances it has been found that oil could not be pumped from wells which were known to be flowing or yielding, and upon investigation it was ascertained that the pressure of the gases at the bottom of the well had forced open the lower valve—keeping it open—its own specific gravity or weight not being sufficient to overcome the same, and consequently the pump would not work nor bring up the oil.

The object of my invention is to remedy this evil by providing a means of escape for the gases below the lower box and between it and the upper box, and this I do by providing smaller tubes or pipes, which pass outside of the lining or main tube and which open into it at proper points, having stop-cocks above the surface of the ground.

In the drawings, Figure 1 represents a side elevation of my invention; Fig. 2, a vertical

section of the tubes; Fig. 3, a horizontal section of the same in line *a b*.

A represents the lining-tube; B and C, the upper and lower valve-boxes; C' and C'', the escape gas-tubes; D and D', the stop-cocks. It will be seen the valves or boxes are located as usual, and the pipes C' and C'' pass outside of the main or lining tube, one entering it between the boxes, the other below the lower one. To the upper end of each one of these a stop-cock is attached. Under ordinary circumstances these are kept closed, but at any time they can be opened to permit the gas to escape from below and between the boxes, relieving the same from injurious pressure. When the flow of gas ceases, the cocks are closed and pumping resumed.

What I claim as new, and desire to secure by Letters Patent, is—

The tubes C' and C'', for the escape of gas from the bottom of oil-wells, thereby relieving the lower valve-box from injurious pressure or opening, which prevents the operation of the pump, the same located and operated substantially as described.

E. H. ASHCROFT.

Witnesses:

JOHN S. HOLLINGSHEAD,
JOHN D. BLOOR.