

J. L. Weaver,
Bonnet.

2 Sheets - Sheet 1

No. 46,163.

Patented Jan. 31, 1865.

Fig. 1



Fig. 2



Witnesses.

Friedrich Austin
A. J. Hale Jr

E E J. L. Weaver
by his attorney
J. E. White

J. L. Weaver,
Bonnet.

2 Sheets, Sheet 2.

No. 46163.

Patented Jan. 31, 1865.

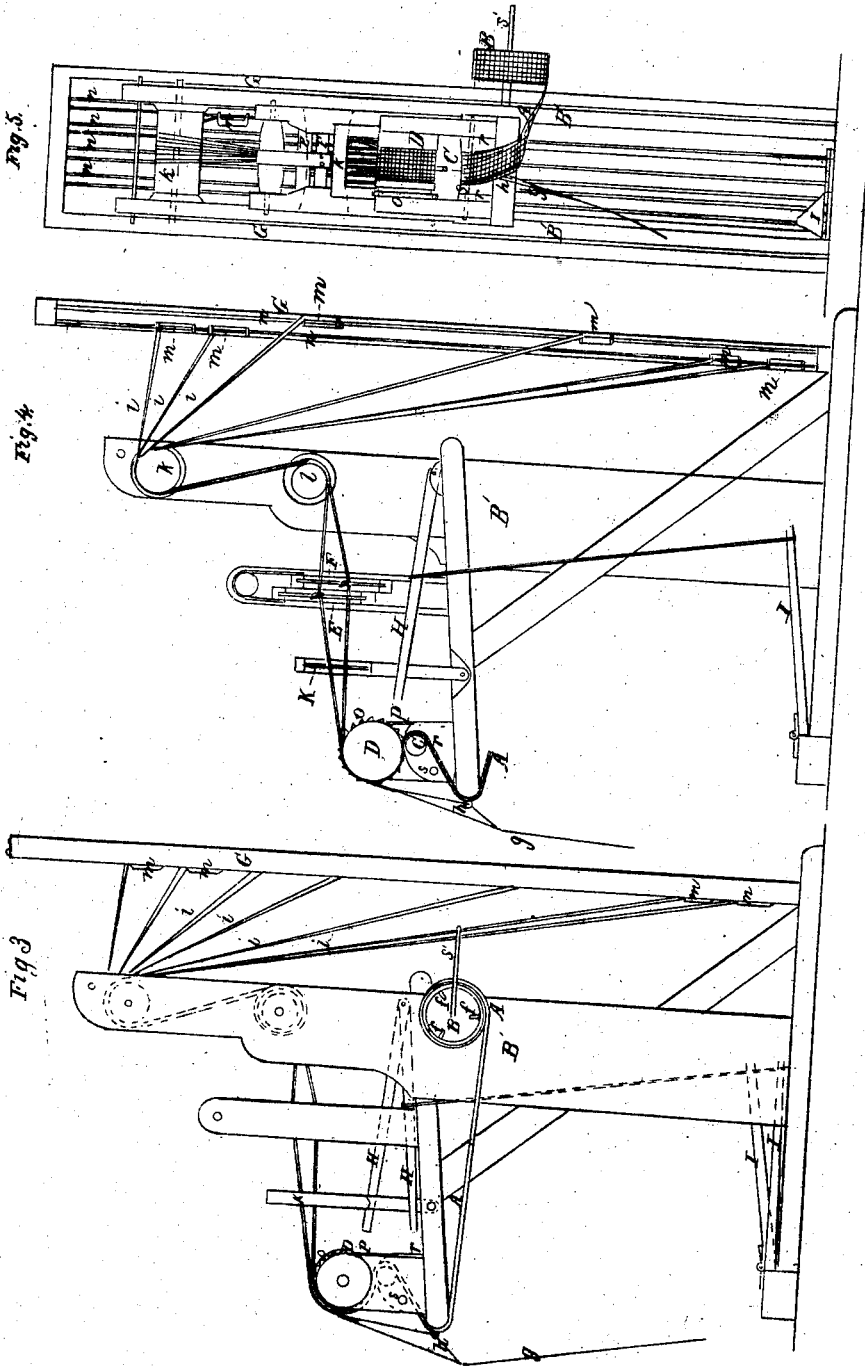

Witnesses
O. P. Hale
W. O. Fisher

J. L. Weaver
By his Attorney
R. H. Wiley

UNITED STATES PATENT OFFICE.

JEFFORD L. WEAVER, OF ORANGE, MASSACHUSETTS.

IMPROVEMENT IN MAKING BONNET-BINDING.

Specification forming part of Letters Patent No. 46,163, dated January 31, 1865.

To all whom it may concern:

Be it known that I, JEFFORD L. WEAVER, of Orange, in the county of Franklin and State of Massachusetts, have invented an Improved Manufacture of Palm-Leaf Bonnet-Binding; and I do hereby declare the same to be fully described in the following specification, and represented in the accompanying drawings, of which—

Figure 1 denotes the mode of laying the strands of the warps for weaving the said binding. Fig. 2 is a representation of a portion of the binding. Fig. 3 is a side elevation of the loom for weaving the braid or band. Fig. 4 is a vertical and longitudinal section of such loom. Fig. 5 is a rear elevation of it.

In the said Figs. 3, 4, and 5 the band or braid is represented at A as extending from a winding-roller, B, arranged on the side of the loom-frame B and on a stationary spindle projecting therefrom. The circumference of this roller has three deep creases or notches, *fff*, made transversely across it, the same being for the purpose of enabling tying-strings to be passed through these notches while the braid is wound on the roller. These tying-strings, after having been carried through the notches, are brought around the layers of braid, and each string has its two ends tied together, after which the braid or band may be separated near the roller. On drawing the roller off its spindle there will be a roll of the braid on such roller, which, in a state fit for the market, may be removed from the roller. On applying the braid or band to the roller, the end of the former is to be inserted in one of the notches.

The braid extending from the roller B goes forward underneath another or elastic roller, C; thence upward and between the said roller and another roller, D, placed directly over the roller C; thence the braid passes about the roller C, the warp-threads being carried through two harnesses, E E. Each warp-thread at its rear end is fastened to a string, *g*, which, if desirable, may have a weight suspended from it, or such string may be held in the hand of the weaver, or be attached to or run through a staple, *h*. The other end of the warp has a string, *i*, fastened to it, which, after being led around guide-pulleys *k l*, is attached to one of a series of weights, *m m m*,

which slide respectively on wires *n n n*, arranged at suitable distances apart and within a vertical frame, G. The frame and its wires serve to keep the weights in their proper positions and the strings from becoming tangled or twisted together. The harnesses have two levers, H H, and foot-treadles I I, for enabling them to be operated by the weaver, and furthermore, the loom is provided with a lay, K, to be worked by the weaver. The roller D is provided with a ratchet, *o*, which is fixed on one end of it, and engages with a spring-catch, *p*, projecting from the loom-frame. Furthermore, each of the journals of the elastic roller C is supported in the upper arm of a lever, *r*, whose fulcrum is a rod, *s*, which, with the lever, is arranged as shown in Fig. 4. The arrangement of the roller C causes the draft of the weights on the braid or band to draw such roller backward, so as to cause it to clamp the braid or band against the roller D, whereby the braid or band will be held firmly by the two rollers against the draft of the weights. The action of winding up the braid or band on the roller B, which is provided with a crank, *s'*, causes the roller C to move forward and unclamp the braid. The roller C operates like the clamp-tongue of a buckle.

In the common way of weaving bonnet-braid of palm-leaf it has been customary to make it in short pieces of about the length of a palm-leaf. A number of strips of a leaf being arranged together as warps in a weaving-machine had a filling or weft of palm-leaf woven into them, the whole, when completed, constituting a ribbon of palm-leaf of about two feet and six inches in length.

My improved braid or manufacture may be made of any length, and so as to be rolled or coiled up in rolls for use or for sale in the market.

In the fabrication of my said manufacture the several filaments or strands of palm-leaf are to lap by one another, or to be arranged as shown at *a b c d e* in Fig. 1—that is, edge to edge, and with one strand either projecting beyond or falling back of that next adjacent to it. As fast as each strand may be nearly woven into the web another strand is to be added in continuation of it and so as to lap flatwise on it, the lapping end of the added strand being held in place by means of a

string attached to it, and passing rearward and having a weight suspended to it. The opposite end of the strand is also to be held in place in the collection by another string extending from it. In this way, as each strand may be worked up, it is to have another laid in continuation of it and woven into the web with the others. As the strands lap by one another the web will keep them in place in the web, and in this way a continuous ribbon or strip of any desirable length may be made.

The advantages of my invention over the common palm-leaf binding is that in its manufacture and use there is a great saving of material. It is easier made. It has greater

uniformity in several respects, and, besides, can be cut of any desirable length.

I claim as my invention—

The above-described continuous bonnet-binding, the same being produced by arranging the warps or strands alongside of and so as to lap by and on one another, as explained, holding each strand in place by means of strings and weights until woven into place, and finally connecting the warps by a filling or weft woven into them, substantially as specified.

JEFFORD L. WEAVER

Witnesses:

R. H. EDDY,

F. P. HALL, Jr.