

H. T. Carter,
Oscillating Steam Engine.
N^o 48,904. Patented July 25, 1865.

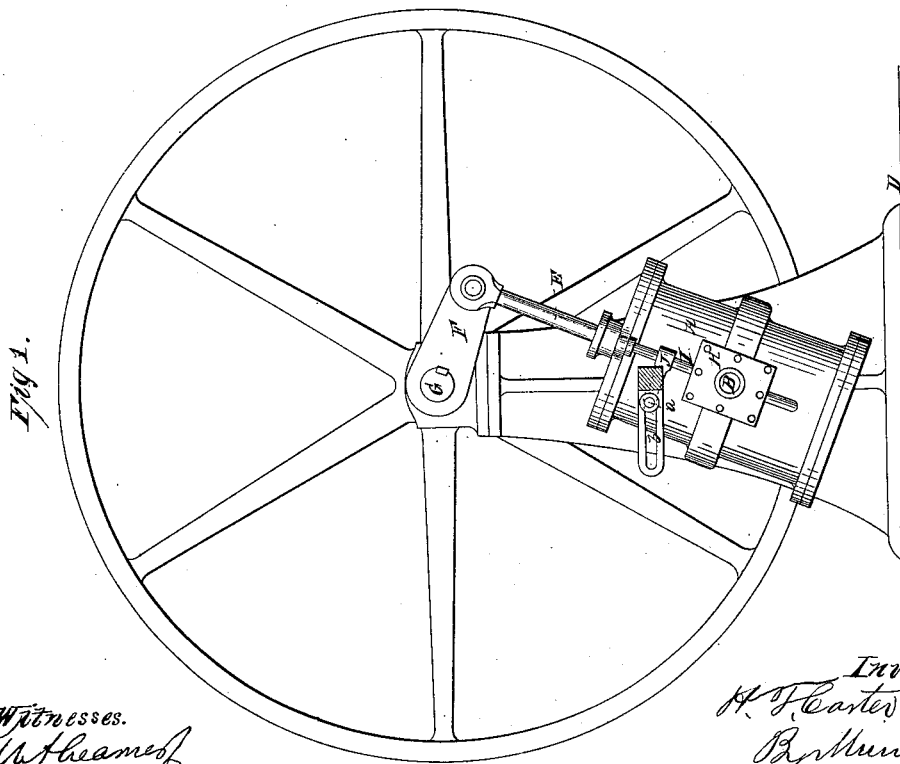
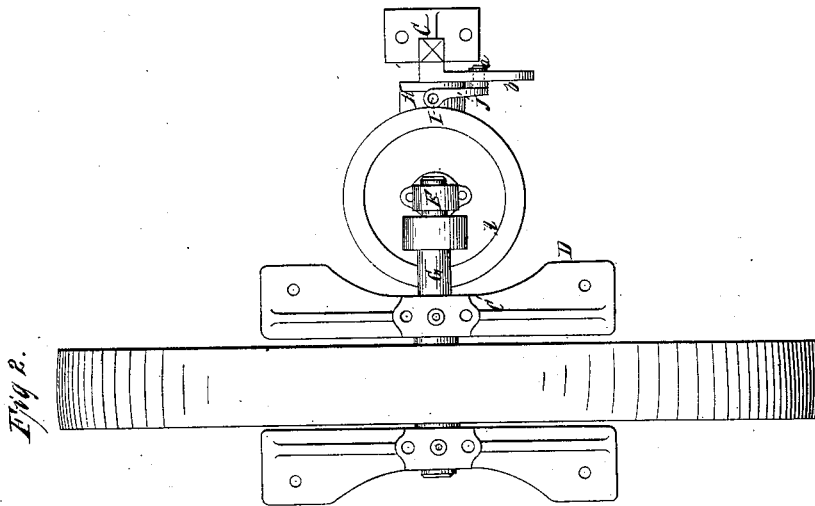

Witnesses.
W. H. Adams
J. M. Condit

Inventor.
H. T. Carter,
*By *Wm. H. ...**
...

UNITED STATES PATENT OFFICE.

HENRY T. CARTER, OF PORTLAND, MAINE.

IMPROVEMENT IN VALVE-GEARS FOR OSCILLATING ENGINES.

Specification forming part of Letters Patent No. 48,904, dated July 25, 1865.

To all whom it may concern:

Be it known that I, HENRY T. CARTER, of Portland, Cumberland county, State of Maine, have invented a new and Improved Valve-Gear for Oscillating Steam-Engines; and I do hereby declare that the following is a full, clear, and exact description thereof, which will enable others skilled in the art to make and use the same, reference being had to the accompanying drawings, forming part of this specification, in which—

Figure 1 is a sectional side elevation of this invention; Fig. 2, a plan or top view of the same.

Similar letters of reference indicate like parts.

This invention consists in the arrangement of a stationary link, in combination with an arm extending from the valve-stem of an oscillating steam-engine, in such a manner that by the combined effect of this stationary link and the oscillating motion of the cylinder the requisite reciprocating motion is imparted to the valve-stem and the valve is changed at the proper intervals.

A represents an ordinary steam-cylinder, which is hung on trunnions B, that have their bearings in suitable standards, C C', rising from the bed-plate D, or which are otherwise arranged in such a manner that the cylinder is free to oscillate in either direction. The piston-rod E connects directly to the wrist-pin of the crank F, which is mounted on the end of the fly-wheel shaft G in the usual manner, and the reciprocating motion of the piston is converted into a continuous rotary motion of the fly-wheel.

Secured to the side of the cylinder next to one of the standards, C, is the valve-chest H, and the stem I of the valve extends up through

a lip projecting from the flange at the end of the cylinder, as clearly shown in the drawings. By this arrangement the valve-stem is guided in its up-and-down movement and prevented from being bent or from binding when the engine is in motion. From said valve-stem extends an arm, J, provided with a stud, a, which extends into a slotted link, b, as shown particularly in Fig. 1. This link is rigidly attached to the standard C, and the slot in the same may be rectilinear or curved; but it must be eccentric in relation to the trunnions on which the cylinder oscillates. As the cylinder oscillates on its trunnions the stud a is carried in and out in the slotted link, and by the eccentric shape of said slot in relation to the center of motion of the cylinder the valve is caused to assume a reciprocating motion. It will be easily understood by practical engineers how the slotted link has to be placed in order to cause the requisite change in the position of the valve at either end of the stroke of the piston.

The simplicity of this valve-gear is unsurpassed. It can be readily applied to oscillating engines of any desired description, whether the cylinder oscillates on a horizontal or on a vertical axis, and if the link is once properly adjusted the valve-gear will require no further adjustment.

I claim as new and desire to secure by Letters Patent—

The arrangement of the stationary slotted link b, projecting laterally from the standard c, arm J, valve-stem I, and oscillating cylinder A, all as and for the purposes specified.

HENRY T. CARTER.

Witnesses:

GEO. E. B. JACKSON,
WM. C. TEN BROECK.