

G. L. Hutchinson

Wheel Cultivator

N^o 52,049.

Patented Jan. 16, 1866.

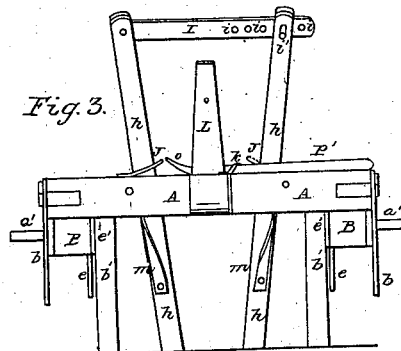
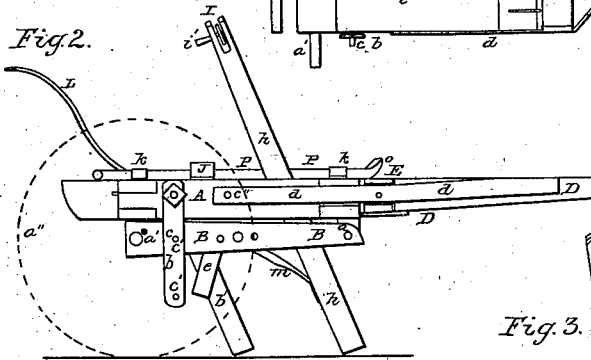
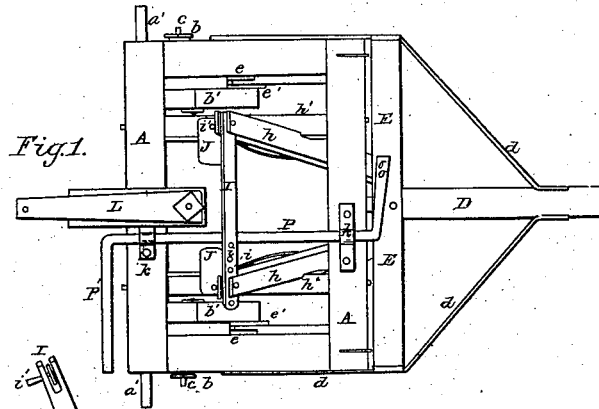

Witnesses:
W. H. Burdick
A. W. McDelland.

Inventor:
G. L. Hutchinson.

UNITED STATES PATENT OFFICE.

G. L. HUTCHINSON, OF WHITE ROCK, ILLINOIS.

IMPROVEMENT IN CULTIVATORS.

Specification forming part of Letters Patent No. 52,049, dated January 16, 1866.

To all whom it may concern:

Be it known that I, G. L. HUTCHINSON, of White Rock, in the county of Ogle and State of Illinois, have invented certain new and useful Improvements in Cultivators; and I do hereby declare that the following is a full and complete description of the construction and operation of the same, reference being had to the accompanying drawings, making a part of this specification, in which—

Figure 1 is a plan view of the cultivator. Fig. 2 is a side view. Fig. 3 is a view of the rear end.

Like letters of reference refer to like parts in the several views.

My improvement relates to cultivators, as hereinafter described.

A represents the frame of the cultivator, that is of a rectangular form, to the sides of which, underneath it, are connected axle-trees B, hinged or jointed at *a* to the front of the frame, that extend back and are supported at the rear end by metallic braces *b*. The braces are secured to the axle-trees by pins *c* being put through holes in the braces into the axle-trees. There are adjustable braces or stays *e* also extending down inside from the frame through a space cut out in the axle-tree, over which there is a plate, *e'*, forming a slot, so that the braces inside can be adjusted to the position of the axle-trees, for the rear ends of the axle-trees can be raised up or down and secured by means of holes *c'* and pins. At the rear ends of the axle-trees project axles or journals, *a'*, on which the wheels of the cultivators are placed, as indicated at *a''* in Fig. 3.

To the sides of the frame is pivoted, at *c''*, braces *d*, that are attached to the ends of a cross-piece, E, in front of the frame, from which they incline toward the tongue, and are secured to it.

b' b' are standards extending down in an inclined position from the frame, to which cultivator-blades are designed to be attached.

h h are vibrating arms secured to rock-shafts *h'*, that have their bearings in the frame. Between the arms *h*, at the top, that extend above the frame, is a connecting rod or bar, I, pivoted at the ends by slots in the arms, there

being an adjustable pin, *i*, in one end, that, by means of holes *i* in the bar, the upper ends of the arms can be secured nearer or farther from each other, by which the distance between the blades at the lower end is regulated.

J J are foot-pieces attached to the top of the rock-shafts, by which they can be vibrated with the feet of the driver sitting on a seat secured to the standard L.

m m are braces attached to the rock-shafts and arms *h*.

P is a bent lever extending across the top of the frame through journal-boxes *k*, whereby the frame can be moved up or down, elevating or lowering the blades, or the tongue is adjustable in its connection with the frame. By raising the end P' of the lever the other end, *o*, presses against the cross-piece E, and by means of the braces *d* being pivoted to the sides of the frame the frame can be raised more or less, as may be desired; and the frame can be set up higher from the ground by securing the axle-trees to the lower end of the braces *b* by means of the adjustable pin *c* and holes *c'*, as before stated.

There are slots in the upper ends of the standards *b'*, where they are secured to the frame by a bolt and nut passing through the slot, so that the standards can be adjusted up or down in relation to the frame.

By means of the vibrating arms *h* the inner blades can be moved so as to agitate or loosen up the ground in the desired manner by the driver taking hold of the cross-bar I, or by the foot-pieces, as before stated.

What I claim as my improvement, and desire to secure by Letters Patent, is—

1. The rock-shafts *h'*, arms *h*, and standards *b'*, in combination with the axle-trees B and adjustable braces *b e*, when arranged as and for the purpose set forth.

2. The arrangement of the lever P and adjustable tongue D, in combination with the frame A and axle-trees B, when hinged together as and for the purpose described.

G. L. HUTCHINSON.

Witnesses:

C. W. NORTON,

G. SERIL ELBERT.