

S. Crowell,

Iron Fence.

No. 108,112.

Patented Oct. 11. 1870.

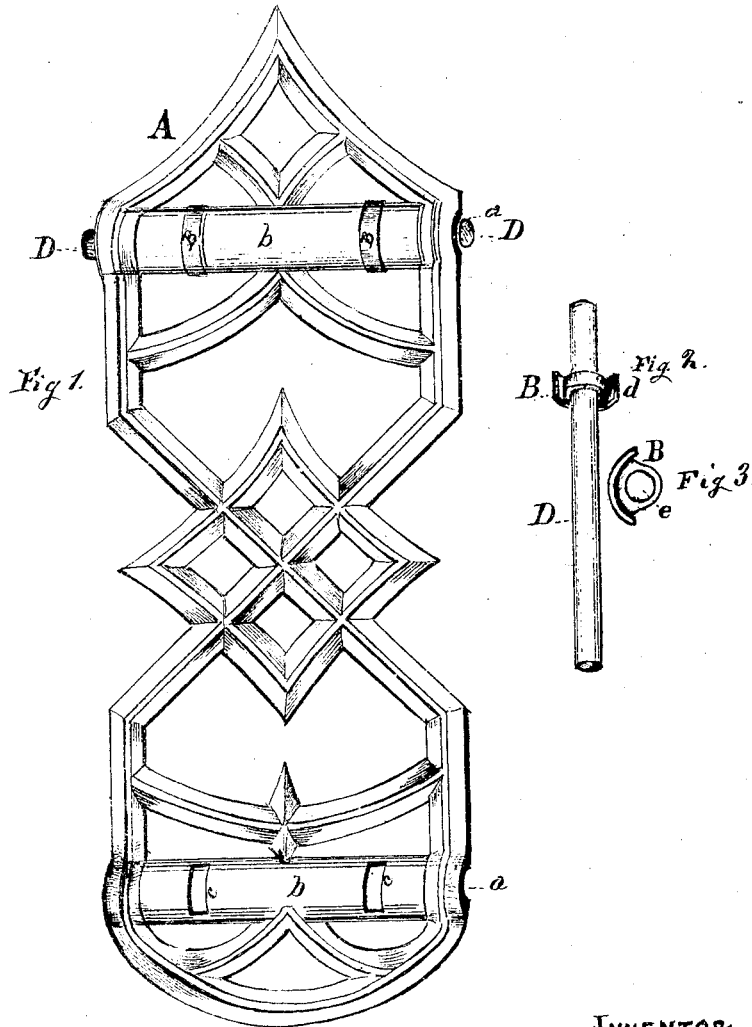

WITNESSES:

Samuel Swain Jr
Walter L. Crowell

INVENTOR:

Sommers Crowell

United States Patent Office.

SOMMERS CROWELL, OF PHILADELPHIA, PENNSYLVANIA.

Letters Patent No. 108,112, dated October 11, 1870.

IMPROVEMENT IN IRON FENCES.

The Schedule referred to in these Letters Patent and making part of the same

I, SOMMERS CROWELL, of the city of Philadelphia, and State of Pennsylvania, have invented certain Improvements in Cast-iron Railings, of which the following is a specification.

The nature of my invention consists in a novel mode of connecting the pales of a cast-iron fence with the longitudinal rails or rods of the same, whereby bolts or rivets are dispensed with, the pales and rails being held together by means of cross-grooves in the rear side of the former, which receive the latter, and clasps connected with the same, which hold the rails in place, as hereinafter described.

To enable others to apply my invention to practice, I will now give a full description thereof.

In the accompanying drawings which make a part of this specification—

Figure 1 is a front elevation of one of the pales A, clasps B B at its upper end, and a portion of rail D in connection.

Figure 2 is a perspective view of a piece of one of the rails D and clasp B.

Figure 3 is a side view of one of the clasps B.

Like letters in all the figures indicate the same parts.

A represents one of the pales of the fence, which has semicircular grooves *a* in the rear side of the projections *b*, for the reception of the rails or rods D.

One or more clasps B, are passed through slots *c*, seen in the lower projection *b*. These clasps are provided with flanges *d*, which are brought against the front side of the projections *b*, and when in position, the eyes *e*, are in range with the semicircular grooves *a*, so that, when the rails or rods D are pushed through the eyes *e* into position, as represented in fig. 2, they

are held securely in the grooves *a*, the outer portions of the eyes opposite the grooves binding on the rear side of the rails or rods sufficiently tight to hold them securely in the grooves. One of the clasps B is represented in detail in fig. 3.

It will readily be seen that the pales and clasps may be cast sufficiently accurate to admit of the fence being put together as they come from the foundry without any finishing; and that, there being no screws or rivets necessary in confining all the parts of a panel together, the fence may be cheaply made, and at the same time have a neat finish. The rails or rods, being covered in front by the projections *b*, are not seen in front of the fence. If desired, the clasps B may be so constructed as to have an even finish with the face of the pales, by dispensing with the flanges *d* and countersinking the heads. The heads of the clasps B may have a carved or other finish, with the projections *b*, to look like a part of the same.

The drawings represent round rails; yet the improvement, it will be seen, is adapted to any form of rails by having the grooves *a* of the pales, and the eyes *e* of the clasps, of corresponding form.

What I claim as my invention, and desire to secure by Letters Patent, is—

The clasps B, formed as described, with ring portion *e*, in combination with the pales A, having the slots *c* and horizontal groove or depression *a* adapted to the form of the rail or rod D which passes through the ring *e*, all constructed substantially as described.

SOMMERS CROWELL.

Witnesses:

P. HAFFA,
H. F. JONES.