

F. C. MORSE.

Ore Mill.

No. 108,617.

Patented Oct. 25, 1870.

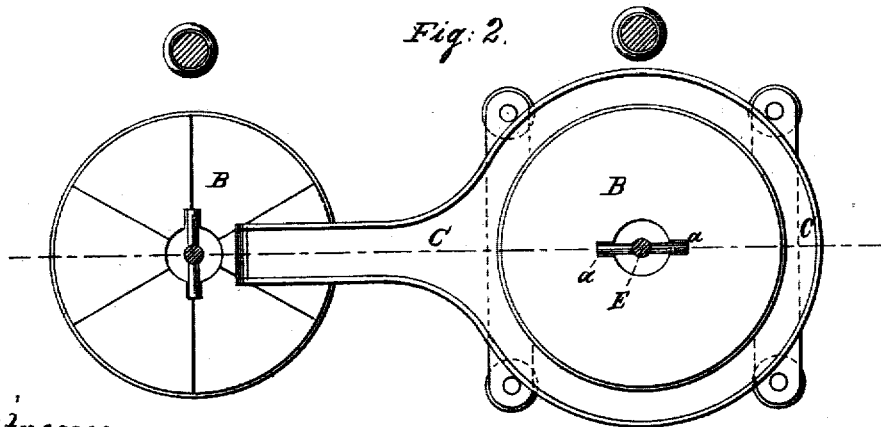
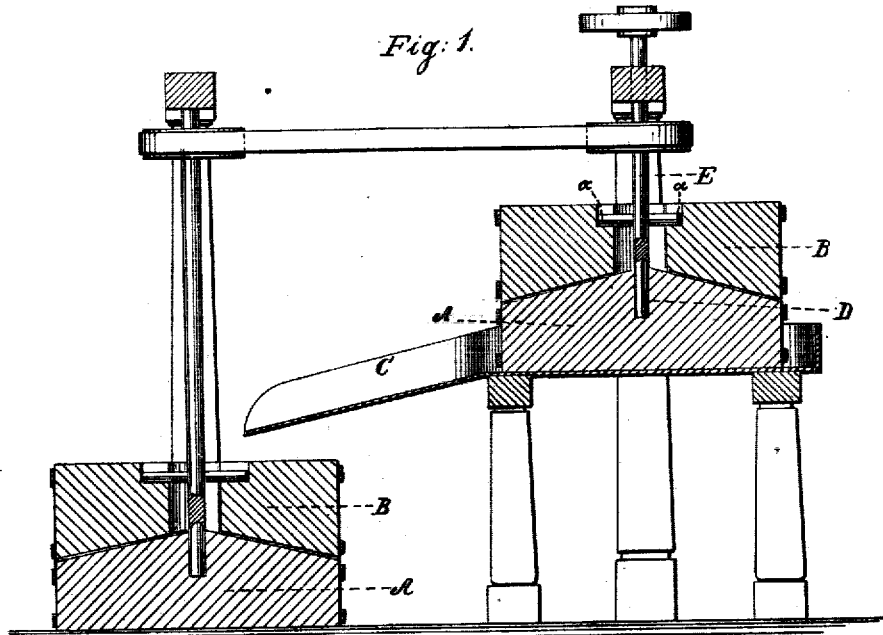

Witnesses.

Gustave Dietrich
S. S. Mabee

Inventor.

F. C. Morse
per *Wmms*
attys

United States Patent Office.

FREDERICK C. MORSE, OF BUCKSKIN, COLORADO TERRITORY.

Letters Patent No. 108,617, dated October 25, 1870.

IMPROVEMENT IN ORE-PULVERIZERS.

The Schedule referred to in these Letters Patent and making part of the same.

To all whom it may concern:

Be it known that I, FREDERICK C. MORSE, of Buckskin, in the county of Park and Territory of Colorado, have invented a new and improved Ore-Pulverizer; and I do hereby declare that the following is a full, clear, and exact description thereof, which will enable others skilled in the art to make and use the same, reference being had to the accompanying drawing forming part of this specification.

Figure 1 represents a vertical longitudinal section of my improved ore-pulverizer.

Figure 2 is a plan or top view of the same.

Similar letters of reference indicate corresponding parts.

This invention relates to an improved arrangement of the grinding-stones in an ore-pulverizer, or a new method of hanging them, and consists in providing the convex bedstone with a step, on the end of which the driver of the upper or rotary concave stone is placed.

A and B in the drawing are the two grinders, which constitute my pulverizer. They are made of stone or other suitable material, and their grinding surfaces may be burred in the usual manner or otherwise prepared at will.

The lower fixed grinder A is made with a conical grinding surface so as to be higher in the middle than at the edges, as shown.

The upper rotary grinder B, which may be made of one or more pieces, as desired, has its grinding surface concave to correspond with the shape of the lower grinder.

The ore to be pulverized is inserted between the grinders through a central opening of the upper grinder.

D is a step inserted in the stone A at its center. On this the driver E is set, its lower end being recessed for the purpose. At the upper end it is arranged in suitable supports, and its horizontal arms

a a project into recesses or notches in the stone B; thus motion being imparted to the driver by means of a band and pulley, or other means, the stone B will be rotated.

This arrangement is simple, inexpensive, and adapted to facilitate removal of the upper stone to receive a new dressing, or for other purposes.

The apparatus is intended more particularly for gold ores, and will give an opportunity of removing the small particles of gold from the pulp as soon as they become separated, preventing their being ground any finer than natural size.

On the ordinary flat grinders the ore is exposed for too long a time to the action of the grinders, and its metallic contents are therefore ground or crushed.

I propose to arrange two or more sets of grinders on one apparatus, each set being somewhat higher than the other, as indicated in fig. 1.

The ore is first ground by the highest pair of stones, and is then carried to the next lower pair in a trough, C.

The separated metal is retained by the amalgamating plates immediately after leaving the grinders.

In this manner complete separation without unnecessary labor is produced.

Another advantage of my invention is the scouring and burnishing of the metal and the consequent cleaning of the same.

Having thus described my invention, I claim as new, and desire to secure by Letters Patent—

The arrangement with the stationary convex bedstone A and rotary concave stone B, of the step D and driver E, provided with arms *a a*, all as shown and described.

FREDERICK C. MORSE.

Witnesses:

ASSYRIA HALL,
J. R. FOSTER.