

W. H. Thorne,

2. Sheets, Sheet 1.

Mechanical Movement.

No. 113113.

Patented Mar. 28, 1871.

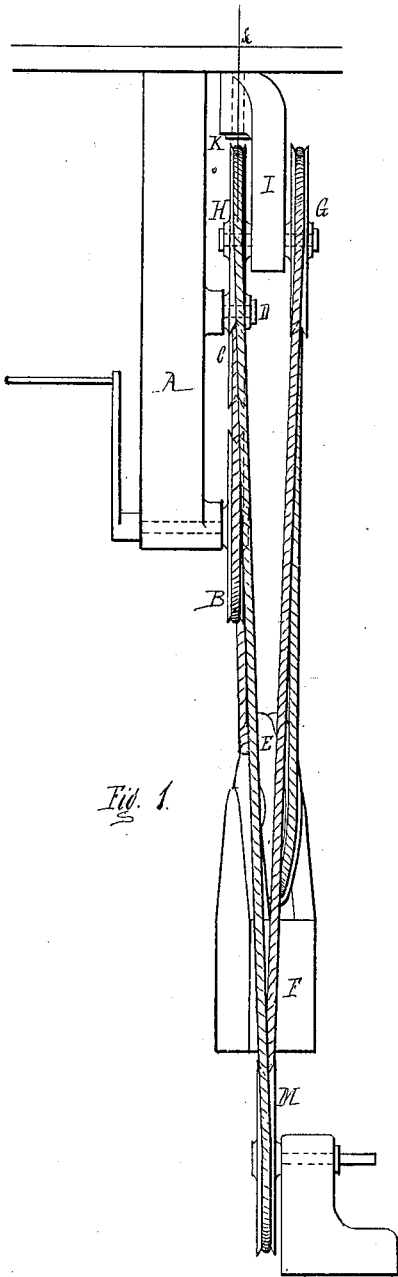

Fig. 1.

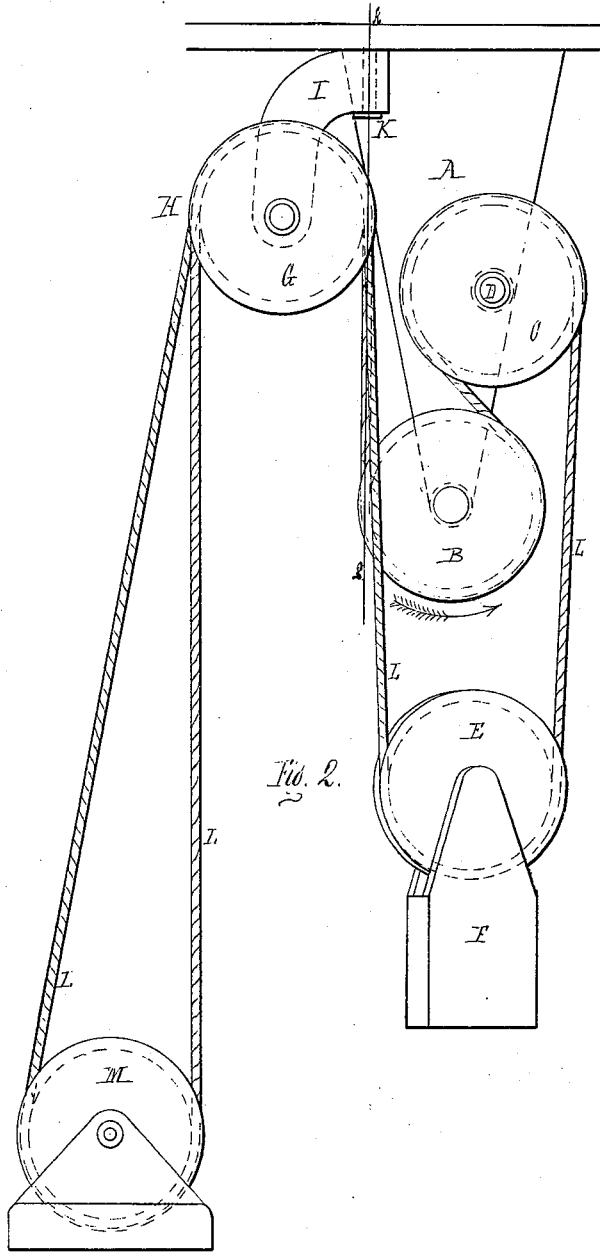

Fig. 2.

Lyman Cutler
Oppm S. Kelley. Witnesses.

Wm. H. Thorne Inventor.

W. H. Thorne,

Mechanical Movement.

No. 113,113.

Patented Mar. 28, 1891.

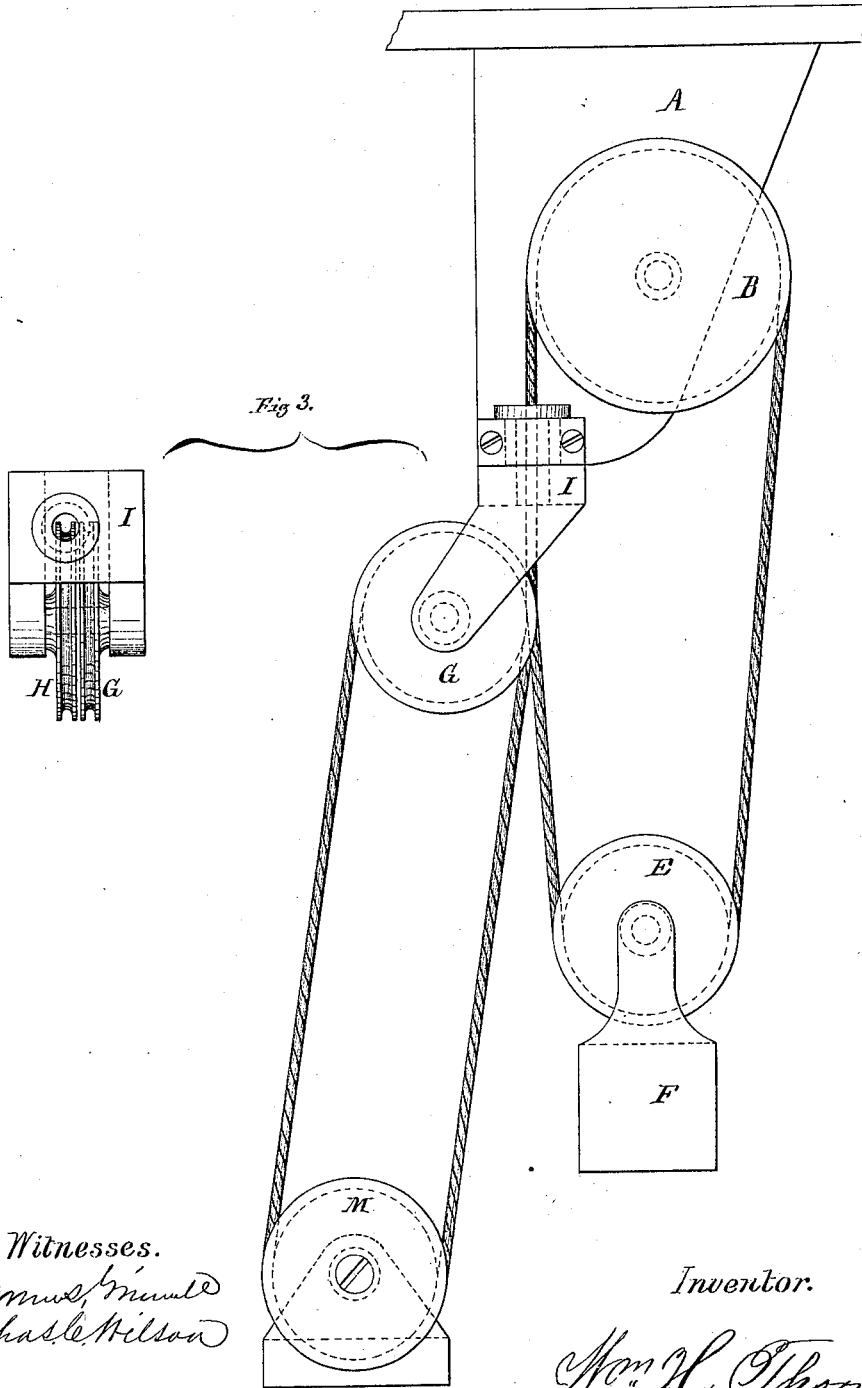

Witnesses.
 James Munnell
 Charles Wilson

Inventor.
 Wm H. Thorne

UNITED STATES PATENT OFFICE.

WILLIAM H. THORNE, OF PHILADELPHIA, PENNSYLVANIA.

IMPROVEMENT IN APPARATUS FOR TRANSMITTING POWER TO MACHINERY.

Specification forming part of Letters Patent No. **113,113**, dated March 28, 1871.

I, WILLIAM H. THORNE, of the city and county of Philadelphia, and State of Pennsylvania, have invented a certain Device for Transmitting Power to a Portable Machine, of which the following is a specification:

Nature and Objects of the Invention.

My invention relates to the combination, with a driving-pulley the shaft of which revolves in a fixed bearing, of one or more idler-pulleys revolving on fixed journals, and one idler-pulley revolving on a journal held in a movable weighted frame, and two idler-pulleys revolving on journals held in a frame or frames, which frame or frames can be rotated in a plane at an angle of ninety degrees with the plane of rotation of the driving-pulley, in such manner that a continuous cord or belt, being properly passed around this series of pulleys, can be used to transmit power to any distance or in any direction, or to a changeable distance and direction, limited, of course, by the length of the cord or belt; the object of the invention being to permit portable drilling and other machines to be driven by a cord or belt at any distance or in any direction from the power.

Description of the Accompanying Drawing.

Figure 1 is front elevation of the device. Fig. 2 is a side elevation of the device. Fig. 3 is a side elevation of a modification.

General Description.

A is a hanger, which supports the bearings for the shaft of the driving-pulley B.

C is an idler-pulley, revolving on a fixed journal, D.

E is an idler-pulley, revolving on a journal held by the weighted frame F, which is suspended by means of the cord or belt L under the idler-pulley E.

G and H are idler-pulleys, revolving on journals held in the frame I, which rotates on the stud K, the axis of which is a vertical line, *k*, coinciding with a line drawn through the center of the cord or belt from where it

leaves the pulley H to where it touches the pulley B.

M is a pulley, for applying the power to the work.

Power is applied to the shaft of the driving-pulley B, which is made to revolve in the direction of the arrow. The cord or belt passes under the pulley B, then over the idler-pulley, H, which is hung on the rotating frame I, so that its delivering side is always in a vertical line with the receiving side of the pulley B. The cord or belt then passes over the pulley M, by which it is applied to the work, and back over the pulley G, also hung in the rotating frame I. It then passes under the pulley E in the weighted frame F, and then up over the idler-pulley C, back to the driving-pulley B.

As the frame I is capable of being rotated on the stud K, and as the frame F is movable and weighted so as to keep a constant tension on the cord or belt, power can be transmitted to the pulley M through the cord or belt L in any direction or at any distance.

Description of Fig. 3.

A is the hanger. B is the driving-pulley. I is a frame, carrying two idler-pulleys, L and H. This frame is suspended so that it can be rotated on an axis corresponding with the axis of that part of the cord or belt leading from the driving-pulley B to the idler-pulley H, and is hollow, permitting the cord or belt to pass through it.

E is an idler-pulley, revolving in a weighted frame, F.

M is a pulley, to which it is desired to transmit motion.

The cord or belt passes over the driving-pulley B, then under the idler-pulley H, then to the pulley M, then back over the idler-pulley G, then under the weighted pulley E, and then back to the driving-pulley B.

The swiveling of the frame I on its point of suspension permits the pulley M to be driven by the cord or belt at any point of a circle having the point of suspension of the frame I

for its center, and the weighted frame F and pulley E permit the radius of this circle to be increased or diminished at will.

Claims.

I claim as my invention—

1. The frame I, carrying the idler-pulley H and rotating on the stud K, in such a manner that the delivering edge of the idler-pulley H will always be in line with the receiving edge

of the driving-pulley B, for the purposes specified.

2. The weighted frame F, carrying the idler-pulley E, used in combination with the swinging frame I, in the manner described, and for the purposes specified.

WM. H. THORNE.

Witnesses:

LYMAN ORTON,
WM. S. KELLEY.