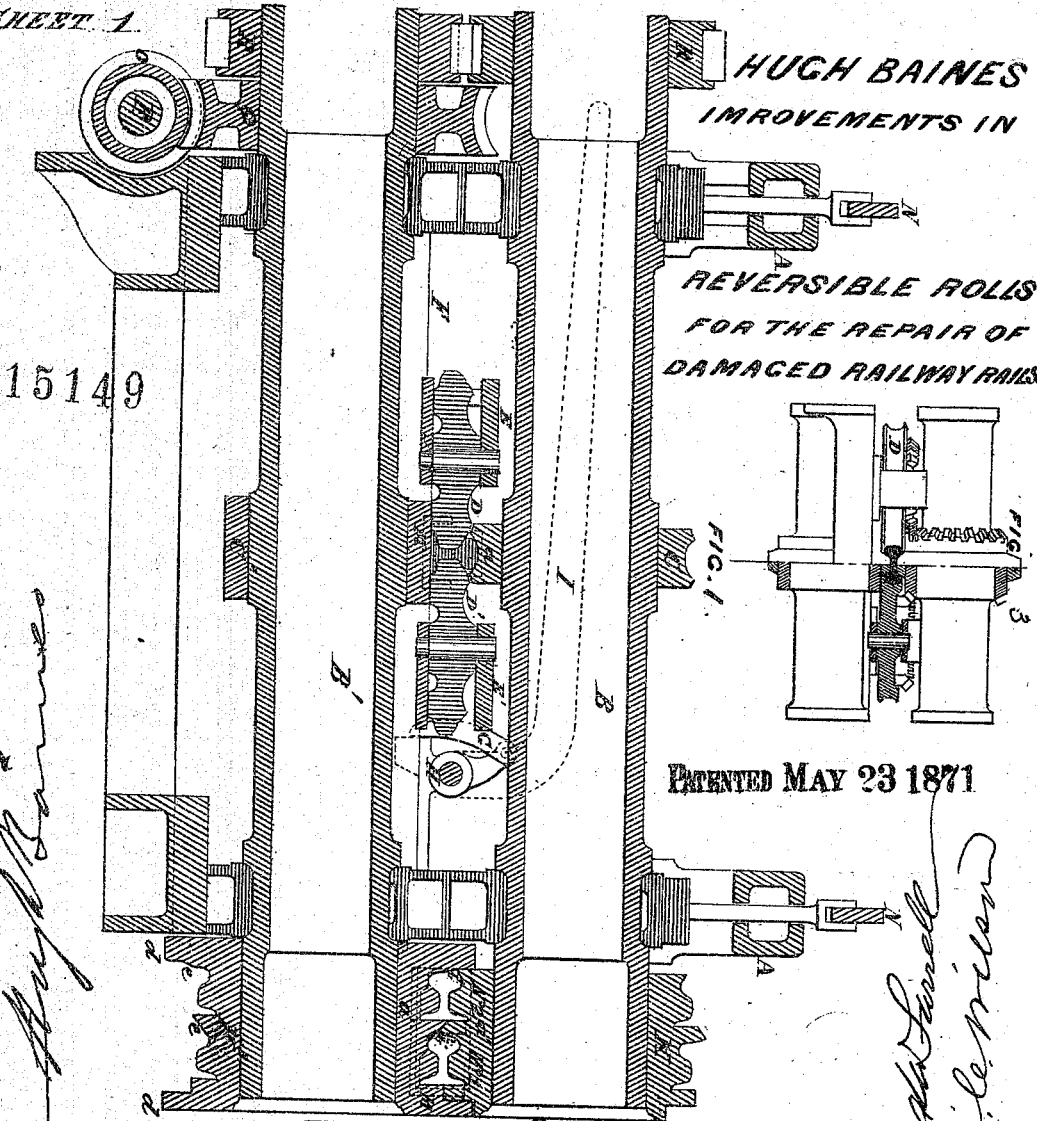


SHEET 1

115149

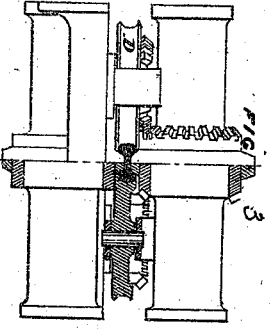
*Inventor*  
*Hugh Baines*

**HUGH BAINES'**  
**IMPROVEMENTS IN**  
**REVERSIBLE ROLLS**  
**FOR THE REPAIR OF**  
**DAMAGED RAILWAY RAILS**

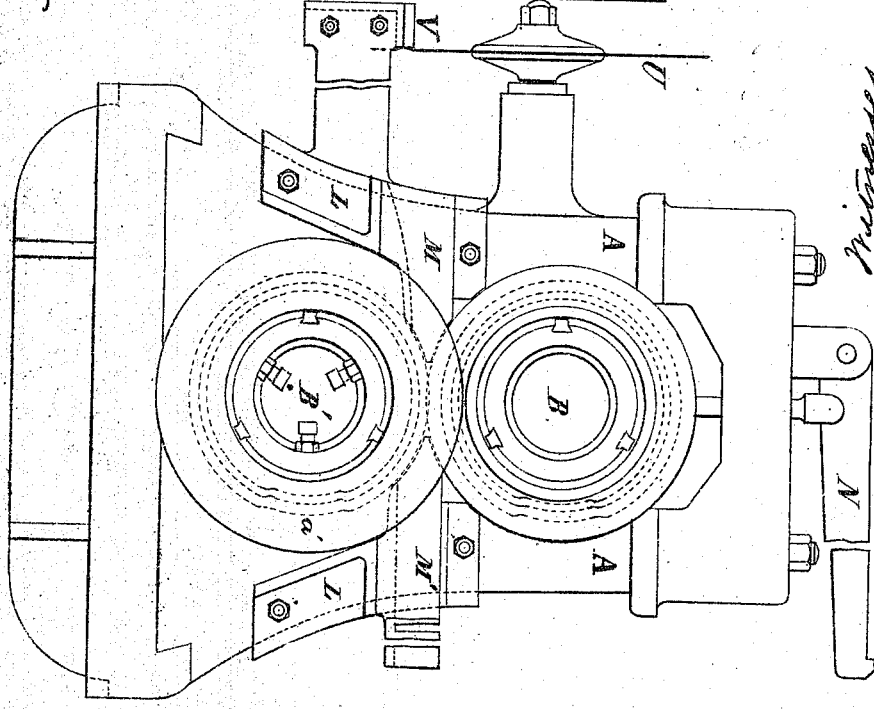


**PATENTED MAY 23 1871**

**FIG. 1.**

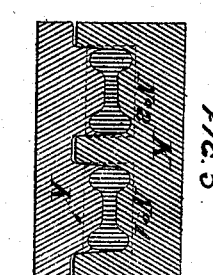
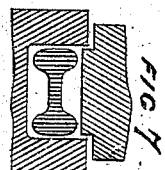
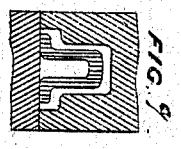
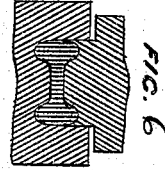
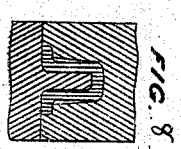
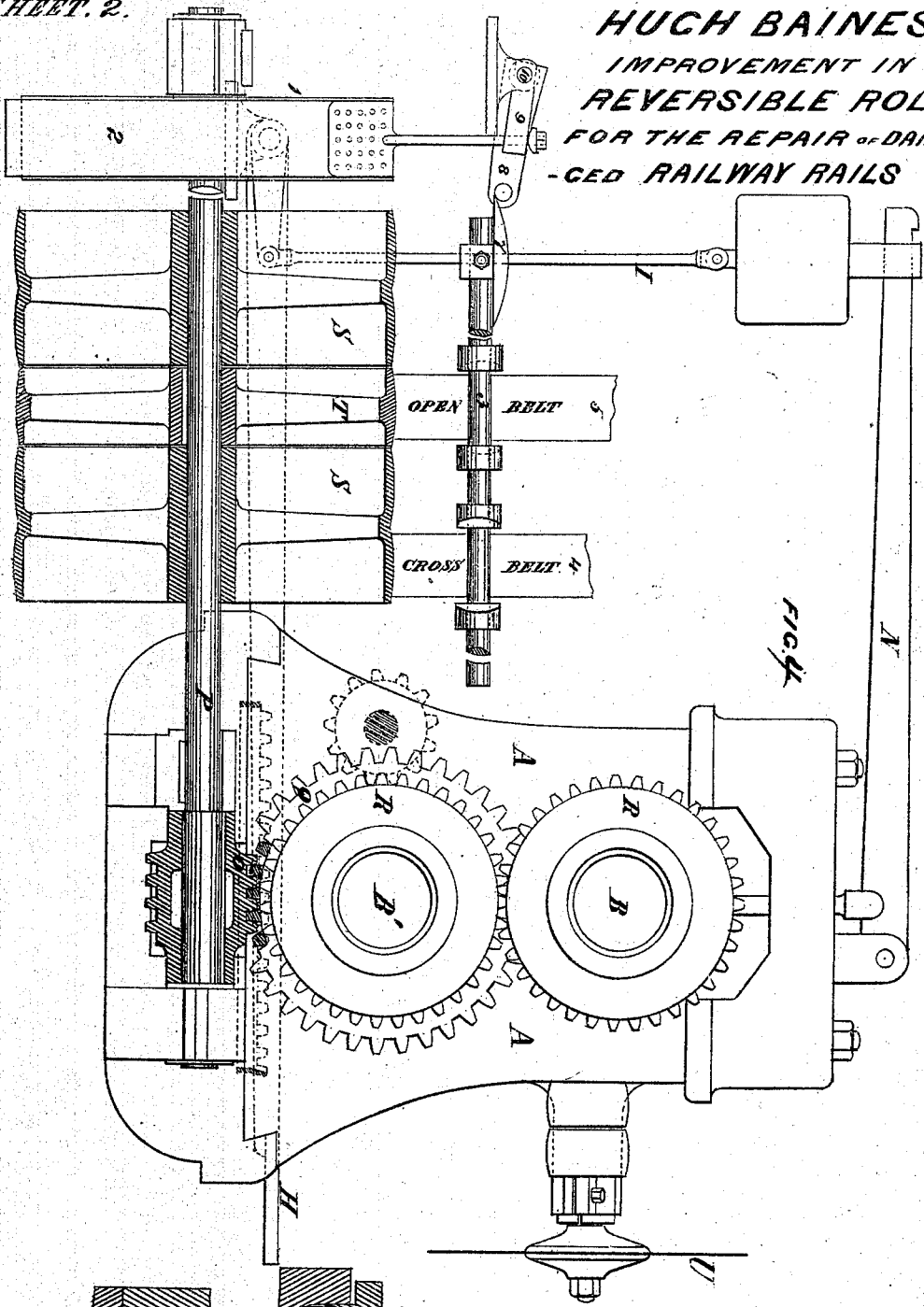


**FIG. 2.**



*Witnesses*  
*Edward S. Lowell*  
*Charles C. Wilson*

**HUGH BAINES'**  
IMPROVEMENT IN  
REVERSIBLE ROLLS  
FOR THE REPAIR OF DAMA-  
GED RAILWAY RAILS



# UNITED STATES PATENT OFFICE.

HUGH BAINES, OF TORONTO, CANADA.

## IMPROVEMENT IN ROLLS FOR PATCHING RAILWAY RAILS.

Specification forming part of Letters Patent No. 115,149, dated May 23, 1871.

I, HUGH BAINES, of the city of Toronto, in the county of York, Province of Ontario and Dominion of Canada, engineer, have invented certain improvements in the passes or grooves and collars of reversible rolls, and in the mode of driving by gear the horizontal rolls for the repair of railway rails with great efficiency and facility.

### *Nature and Objects of the Invention.*

My invention relates to the confining one of a pair of finishing-rolls within the other by means of square collars, in order to keep the rolls in exact position with each other, and the forming of a taper between the finishing-grooves and the square parts of such collars, parts of which taper are cut away, as also parts of the peripheries of the grooves or molded portions of the passes, for the purpose of giving ample freedom in passing cold rails through the rolls, as hereinafter described; and the arrangement of brake and reversing gear, whereby the rolls can be stopped and started at any required position.

### *Description of the Accompanying Drawing.*

Figure 1, Sheet 1, represents a front sectional view of reversible rolls. Fig. 2, Sheet 1, is an end view of Fig. 1. Fig. 3, Sheet 1, is a sectional and front elevation, drawn to a reduced scale, of a pair of horizontal rolls geared together as I propose to use them. Fig. 4, Sheet 2, is a sectional end view taken at the driving or geared end of Fig. 1, Sheet 1. Figs. 5, 6, 7, 8, and 9 represent sectional portions of finishing-rolls for repairing double-headed and U-rails, which may be used interchangeably with rolls B B'.

### *General Description.*

In these figures, A A are the housings. B is the top roll, and B' the bottom roll, shown in section. C is a ring for rolling the top of the flat-footed rail, which is keyed onto the top roll B; this ring is shaped to conform to the shape of the head of the rail, and has a portion cut away, as shown by the dotted lines at *a*, to admit of the cold part of the rail being pushed freely in between the top ring C and the bottom C' keyed on the bottom roll B'. The surface of the bottom ring is plain, in order to roll the flat foot of the rail when patching.

The sides of the rail are rolled by the friction-rollers D D', shaped to correspond thereto; these rollers are contained in carriages E E' resting upon two bearers or frames, the surface of one of which is shown at F. The carriage E is fixed, but the carriage E' is capable of sliding along the bearers F under the action of two wedges, G, (one only of which is seen in Fig. 1,) on the rocking shaft H, to which a long hand-lever, I, shown in dotted lines, is keyed.

On inserting the cold part of the rail the friction-roller D', with its carriage E', moves back to allow it to enter, and when the rolling of the damaged part and patch is to be effected a nip is put on it by the action of the wedges G. On pressing down the hand-lever I the rail is presented to these rolls by a suitable rail-carriage running on its track. When repairing double-headed rails by means of the friction-rollers these rollers must of course be so shaped as to fit the rail. Besides driving the side rolls D D' by friction only, as shown in Fig. 1, Sheet 1, I, when reducing the section of any shaped rail or changing the shape of such when friction is not found to be sufficient, drive such rolls by miter-gearing, as shown in Fig. 1, Sheet 1, which arrangement secures a sure traverse to the rail, of whatever section it may be. After passing through the friction or horizontally-g geared rolls, the rail, whether flat-footed or double-headed, is to be taken on the carriage before mentioned to the double-pass finishing-rings K K', Fig. 1, Sheet 1, hereinafter described, and there completed. The use of the friction-rollers is, however, not absolutely necessary for repairing rails, as they may be repaired by means of double-pass finishing-rolls. The peculiarity of these rings K K', here shown in Fig. 1, Sheet 1, as adapted for the repair of flat-footed rails, is the different shape of the passes that are made therein. The point of junction *b* between the rolls or the open groove in No. 1 pass is left on the lower side, and in No. 2 pass it is left on the upper side, as shown at *b'*, so that the ridge left by one pass is entirely removed by passing the same rail through the other pass, where the rail is finished without having to turn the rail over, as will be readily understood on referring to Fig. 1.

*d d* are square collars for the purpose of con-

fining the roll K within the roll K'. Flats are left on the finishing-rings K K', Figs. 1 and 2, as they are also on the welding-ring C, Fig. 1, as shown by the dotted lines *a a'*. These flats, in conjunction with corresponding flats cut in the tapered shape of the collars of the finishing-rings K K' at *b b'*, Fig. 1, are for the purpose of passing in the cold metal (when repairing centers of rails) up to the damaged part; or the same purpose may be effected by raising the top roll B, or by lowering the bottom roll B', Fig. 1, by cams and levers, weights or screws, or by any other convenient mode; but I prefer using the flats before described, as by that means the rolls remain undisturbed. At this point, the damaged part being at a welding-heat, the rolls are set in motion and the rail repaired. However, when repairing the ends of rails and reducing the sections of old rails, these flats or other means of freeing the rails are not required. L L, Fig. 2, are brackets carrying guide-troughs M M', which are properly divided so as to direct the rail to each particular pass, as required. The hind trough M', shown partly broken away in Fig. 2, Sheet 1, is longer than the entering-trough M, in order to support the rail effectually when repairing the central portion thereof. The top roll B, Figs. 1, 2, and 3, carrying the top ring, is pressed down during the rolling action by weighted levers N N, which press upon the top bearings in the housings, as shown in Fig. 1, the lever over the finishing ends of the rolls being coupled to a foot-lever, H, and rod I, so as to form a powerful compound lever where great pressure is required. The bottom roll B' is driven by means of any suitable gearing; but I prefer to drive it, as shown at Figs. 1 and 4, by means of a worm, O, on a reversing-shaft, P, gearing into a worm-wheel, Q, keyed on the end of the bottom roll; or by pinions, shown in dotted lines on Fig. 4, Sheet 2; or by rack, also shown in dotted lines on the same figure, and worked by hydraulic pressure. The motion of the bottom roll is transferred to the top roll by means of the spur-gearing R R. The shaft P may be reversed by the well-known reversing-clutch; but I prefer to use an open and a crossed strap, in conjunction with two loose pulleys, S S, and a center fast pulley, T. (See Fig. 4.) 1 is a brake-wheel; 2, the brake; 3, a sliding rod, shifting cross-belt 4 and open-belt 5, at the same time put-

ting backward or forward projection 7, which raises or lowers 8 and 9, supported on bearings 10, and so putting on and taking off the brake at the time of reversing the belt, before described, or of stopping and starting the rolls at any required position.

When the rail, whether a flat, double-headed, or bridge rail, has been rolled it is conveyed, while still upon its carriage, to the circular saw U, Figs. 2 and 4, to be cut to the proper length, the rail end resting upon the saw-bracket V; and as it passes across the saw its opposite end passes just in front of a gauge, which, by its action, regulates the length of the rail.

It is to be observed that the various rolls attached to the large rolls B B', Fig. 1, Sheet 1, and the rolls seen in Fig. 3, Sheet 1, and Figs. 5, 6, 7, 8, and 9, Sheet 2, are interchangeable—that is to say, the rolls seen in Fig. 1, Sheet 1, may be substituted for the rolls D D' C C' seen in Fig. 1 on the same sheet, and the rolls shown in Figs. 5, 6, 7, 8, and 9, Sheet 2, may be substituted for the finishing-rings of two passes, K K', seen in Fig. 15, Sheet 1.

Having now described my invention in reversible rolls, I would observe, in conclusion, that I do not in this application claim the invention in rolling-machine invented by me and secured to me by grant of Letters Patent of the United States bearing date the 11th day of December, 1866; nor do I claim the improvements on such machine granted to me by Letters Patent of the United States bearing date the 17th day of December, 1867; but

What I do claim as my present invention is—

1. The particular construction of the roll-sections K K', seen in Sheet 1, Fig. 15, herein described, in virtue of which the rolls are prevented from end play and the metal welded to the head of the rail, and the whole reduced to proper finished shape in two passes, in the manner set forth.

2. The combination of the mechanism for starting, stopping, and reversing, and the rolls, substantially as described.

The above specification of my invention signed by me this 2d day of March, 1871.

HUGH BAINES.

Witnesses:

EDWARD D. FARRELL,  
CHAS. C. WILSON.