

H. M. McINTIRE.

Car-Heater.

No. 214,575.

Patented April 22, 1879.

Fig. 1.

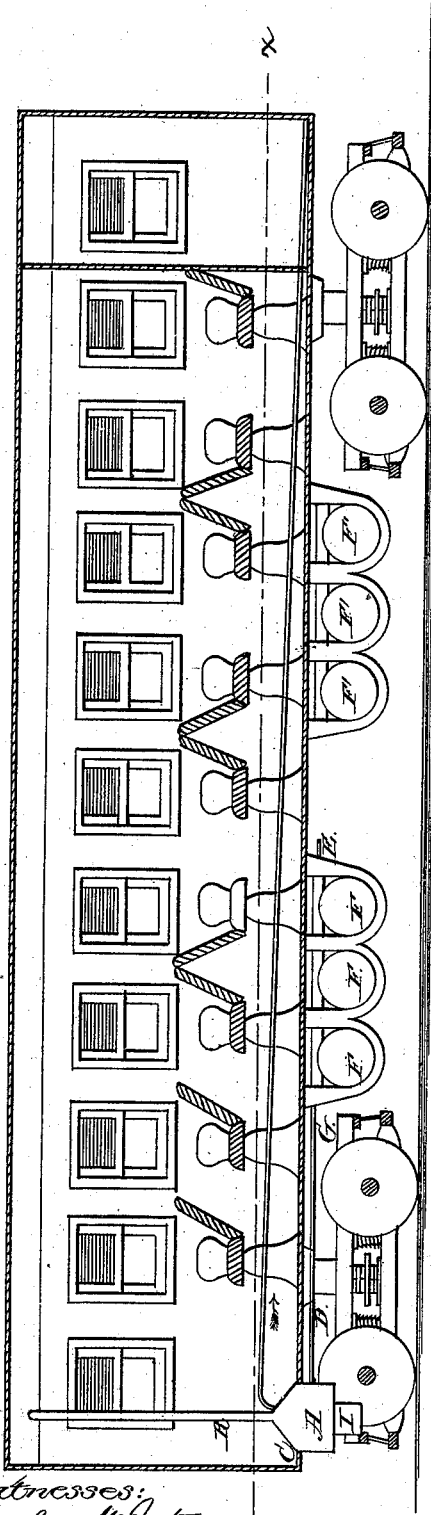

Witnesses:
 Charles McIntire
 Charles McIntire Jr.

Fig. 2.

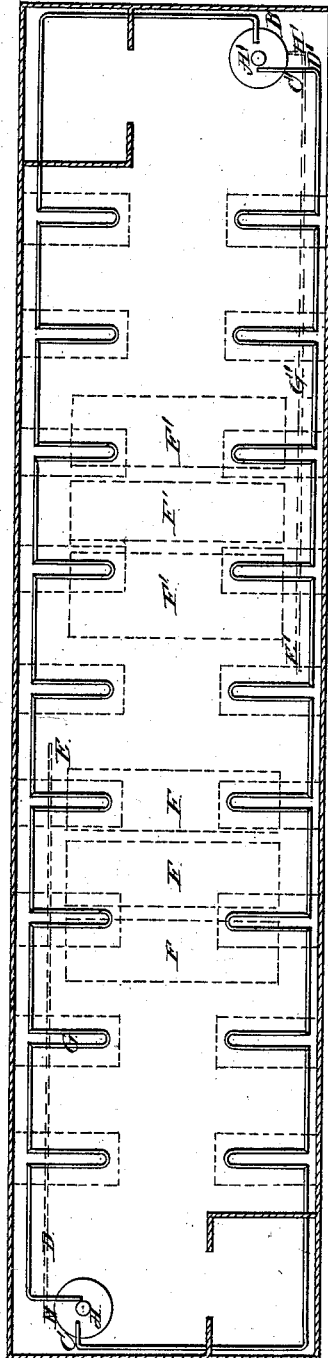

Inventor:
 Henry M. McIntire

H. M. McINTIRE.

Car-Heater.

No. 214,575.

Patented April 22, 1879.

Fig. 4.

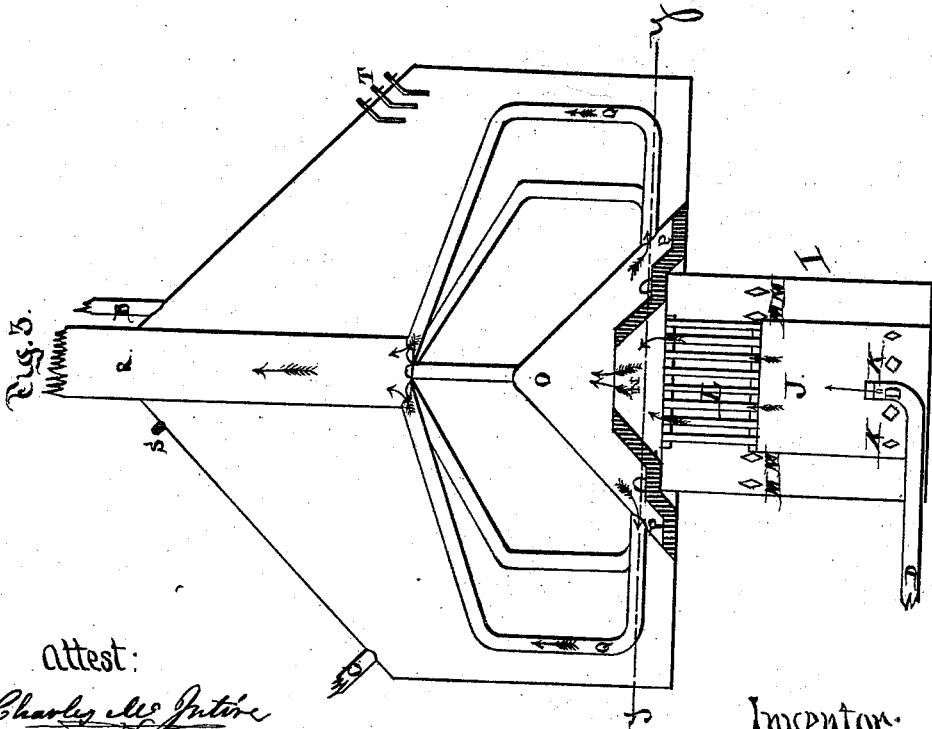
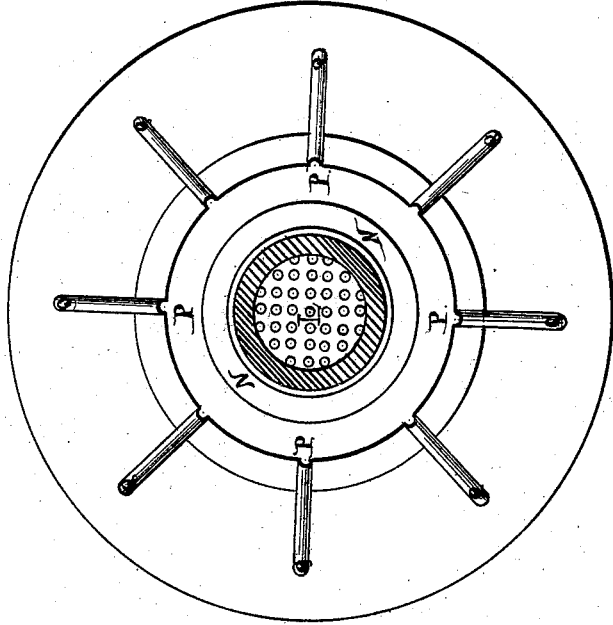

Attest:
Charles M. McIntire
Charles M. McIntire, Jr.

Inventor:
Henry M. McIntire

H. M. McINTIRE,
Car-Heater.

No. 214,575.

Patented April 22, 1879.

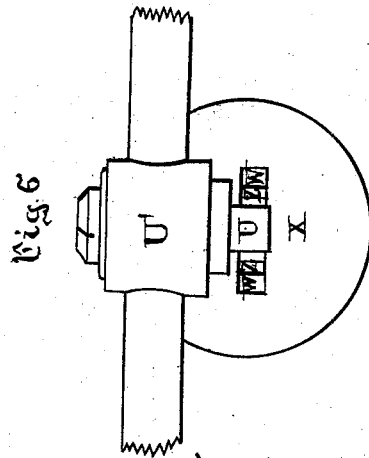
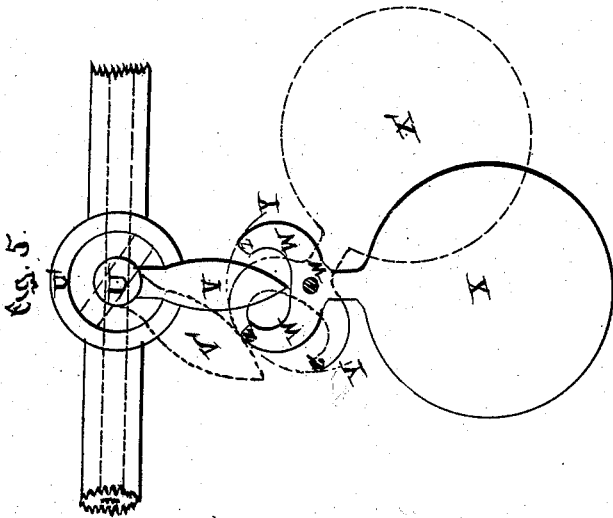
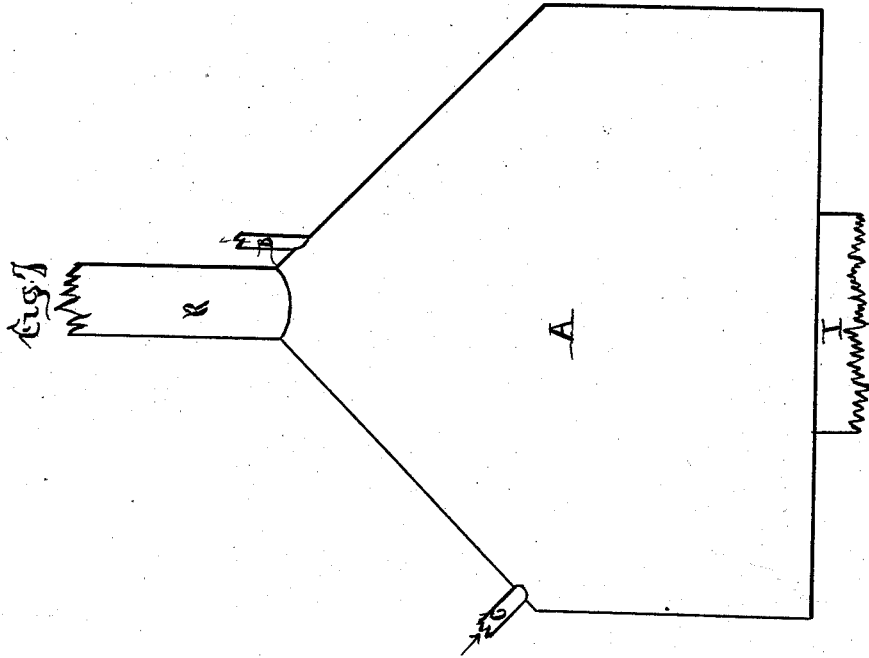

Attest;
Charles McIntire
 Charles McIntire Jr.

Inventor:
Henry M. McIntire

UNITED STATES PATENT OFFICE.

HENRY M. MCINTIRE, OF EASTON, PENNSYLVANIA.

IMPROVEMENT IN CAR-HEATERS.

Specification forming part of Letters Patent No. 214,575, dated April 22, 1879; application filed July 20, 1877.

To all whom it may concern:

Be it known that I, HENRY MAHN MCINTIRE, M. E., of Easton, in the county of Northampton and State of Pennsylvania, have invented in car-heaters a new means for automatically cutting off the supply of fluid fuel to the burner or furnace in case of accident to the car, which is fully set forth in the following specification and accompanying drawings, the explanation of which and reference-letters are as follows:

EXPLANATION OF PLATES.

Figure 1, Plate I, sectional elevation of car, showing boiler, &c., cylinders, and system of pipes; Fig. 2, sectional plan through *xx*, showing boiler, &c., cylinders, and system of pipes; Fig. 3, Plate II, elevation, in section, of boiler and furnace; Fig. 4, plan, in section, through *yy*, of boiler and furnace; Fig. 5, Plate III, vertical, and Fig. 6 horizontal, projections of the gravity-cock; Fig. 7, vertical projection of hot-water heater or boiler.

The references are as follows: A A', Figs. 1, 2, 7, boiler; B B', Figs. 1, 2, 3, 7, steam or hot-water pipe; C C', Figs. 1, 2, 3, 7, steam or hot-water pipe; D E D' E', Figs. 1, 2, 3, gas-pipe; F F', Figs. 1, 2, gas-cylinders; G G', Figs. 1, 2, gas-regulator; H H', Figs. 1, 2, gravity-cock; I, Figs. 1, 3, 7, outside casing of furnace; J, Fig. 3, chamber for mixing gas with air; K, Fig. 3, holes for admitting air to be mixed with gas; L, Figs. 3, 4, tubes for conducting gas and air to be burned; M, Fig. 3, holes for admitting air to supply combustion; N, Figs. 3, 4, fire-bridge; O, Fig. 3, flame; P, Figs. 3, 4, chamber; Q, Figs. 3, 4, tubes or flues; R, Figs. 1, 3, 7, stack; S and T, Fig. 3, safety-valve and gage-cocks; U and U', Figs. 5, 6, valve and valve-seat; V, Fig. 5, handle of valve; W X Y Z, weighted lever.

The object of my invention is to furnish an apparatus for heating cars, so arranged that in case of an accident like the rolling of the car down an embankment the fires will be extinguished.

The fuel is gas, and the vehicle or agent for distributing the heat throughout the body of the car is either hot water or steam, employed in the usual method of using water or steam for heating purposes, being employed to a

great extent at present for heating cars. The gas is stored under pressure in metallic flasks or cylinders placed under the car, while the apparatus is rendered safe by having in the pipe connecting the storage flasks or cylinders with the furnace, (for heating the water or generating steam,) somewhere before reaching the furnace, what might be called a "gravity-cock"—that is, a cock so connected with a suspended weight that when the car is tilted beyond a certain angle, (as in rolling down an embankment,) the weight, tending to be kept by gravity in a perpendicular position, closes the cock, the gas is extinguished wherever it is burning, and any possibility of the flames being communicated by the burning gas to surrounding parts rendered impossible.

My invention may then, for convenience of description, be divided into three parts, as follows: first, the furnace, boiler, and heating-pipes; second, the gravity-cock; third, the reservoirs of fuel.

I. *The furnace, boiler, and heating-pipes.*—As the heating may either be by steam or hot water, there must be two modifications of the boiler—the one for steam, the other for hot water. The one for steam is shown at A and A' upon Figs. 1 and 2, Plate I, and in detail upon Figs. 3 and 4, Plate II. The furnace is seen at I, Fig. 1, in the lower part of Fig. 3, and in the center of Fig. 4. D, in Figs. 1, 2, and 3, is the gas-pipe, leading from the flasks or cylinders F, Figs. 1 and 2. It opens into the chamber J, Fig. 3, where the gas mixes with air, entering through the holes K K K K, Fig. 3; thence it passes up through the tubes marked L, Figs. 3 and 4, and burns above them, air being supplied for the combustion through the holes M M M M, Fig. 3. The part section lined and marked N, Figs. 3 and 4, is of fire-brick, and serves to collect the flame, causing it to pass up into O, Fig. 3, thence turn down to P, Figs. 3 and 4, and pass through the flues Q, Figs. 3 and 4, and up the stack R, Figs. 1 and 3. The steam is generated and passes out the pipe B, Figs. 1, 2, and 3; then passes through the car according to the common method now in use, as shown upon Plate I. Being condensed, it enters the boiler A' at B', Fig. 2, while the steam from A', returning through C', Fig. 2, enters A at C, Figs. 1, 2,

and 3. The boiler is fitted with a safety-valve at S, Fig. 3, gage-cocks at T, Fig. 3, and an injector. (Not shown.)

In the case of the boiler for hot-water heating shown on Fig. 7, Plate III, it is the same as the one just described, except that it has no safety-valve, gage-cocks, or injector. Its position in the car would be the same as that shown at A, Fig. 2; but upon Fig. 1 the whole boiler would be within the car, and not half in and half out, as that shown there, and the arrangement of the pipes would be the same.

The gas-furnace above described is one often used where gas is used as a fuel.

II. *The gravity-cock.*—Before the gas-pipe D, Figs. 1, 2, and 3, passes to the furnace, it connects with the safety gravity-cock. (Shown at H and H', Fig. 2, and in detail upon Figs. 5 and 6, Plate III.) It is nothing more nor less than a common hand-cock, such as is used universally in gas and water fitting. (Indicated by U and U', Figs. 5 and 6, and the handle by V, Fig. 5.) Below this, and encircling it part way, is a horn-shaped piece, W W, swinging upon the axles W', the whole being kept in a perpendicular position by the weight X. Now, if the car should roll over or upon its side, the weight X would, of course, under the action of gravity, tend to keep at the lowest point possible, and so would assume such a position as that indicated by the small broken line, and marked X'. In attaining this position it would push the handle V to the position V', which, as shown by the broken lines and dotted lines at U, would close the cock, while if the weight should endeavor to assume the first position, X, it could do so without altering the cock, as may be seen from the dotted and broken line Y Y', which indicates the path of the most exterior points Z of the part W.

By reference to the drawings it will be seen that there is left a little space or play between the parts W W and the handle V. This is to allow for any oscillation that may occur of the weight X by the motion of the car. The weight X must be heavy and suspended at a short distance from the axis W', in preference to a light weight and a greater distance from the point of suspension. The movement might be the same in each case; but with a heavy

weight and short arm the swinging caused by the motion of the car would be a great deal less than with a lighter weight and longer arm.

III. *The reservoirs of fuel.*—As before mentioned, the gas is stored in large cylinders underneath the car, F F F F' F' F', Figs. 1 and 2. These are the same as those commonly used for storing gas at present. They connect with the gas-pipes D E D' E', Figs. 1 and 2. In these pipes, at some point, as G G', Figs. 1 and 2, must be placed regulators to keep the flow of the gas constant under the decreasing pressure. As the open space under a car is very great, a large number of these cylinders may, if necessary, be placed; and as the degree of compression of a gas is, for all practical purposes, limited only by the strength of the cylinders, the amount of gas that can then be stored up is almost unlimited, so that gas can be pumped into the cylinders, while the car is in the car-house, enough to last for a trip, after which, if needed, it may be replenished.

This, then, is the new and improved car-heating apparatus, and means for automatically cutting off the supply of fluid fuel to the burner, so that it extinguishes the fires in case of an accident like the rolling of a car down an embankment. The method for steam and that for water are almost identical. The boilers are almost the same; could be so, in fact, except for convenience.

A pipe taken from the gas-pipe after it has passed the gravity-cock, and connecting with burners, would serve to make the illumination safe also.

The actual methods of construction are according to the simple and every-day-used methods of any steam and gas fitter.

Having thus described my invention, what I claim as new, and desire to secure by Letters Patent, is—

The gravity-cock shown and described, for automatically cutting off the supply of gaseous fuel to the burner, as set forth.

HENRY M. McINTIRE.

Witnesses:

CHARLES McINTIRE,
CHARLES McINTIRE, Jr.