

A. BURGESS.  
Magazine Fire-Arm.

No. 216,080.

Patented June 3, 1879.

*Fig. 1*

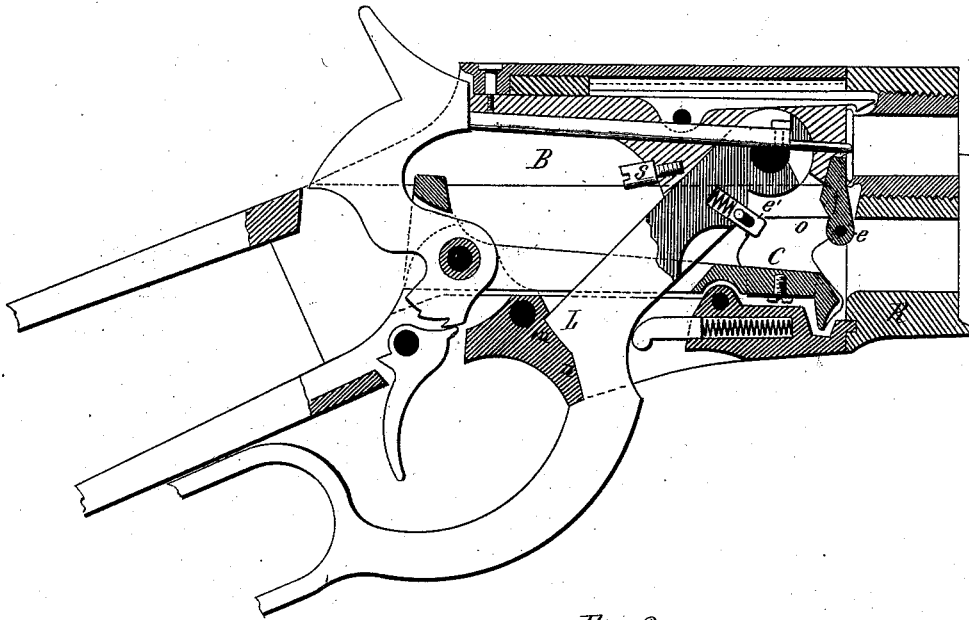

*Fig. 2*

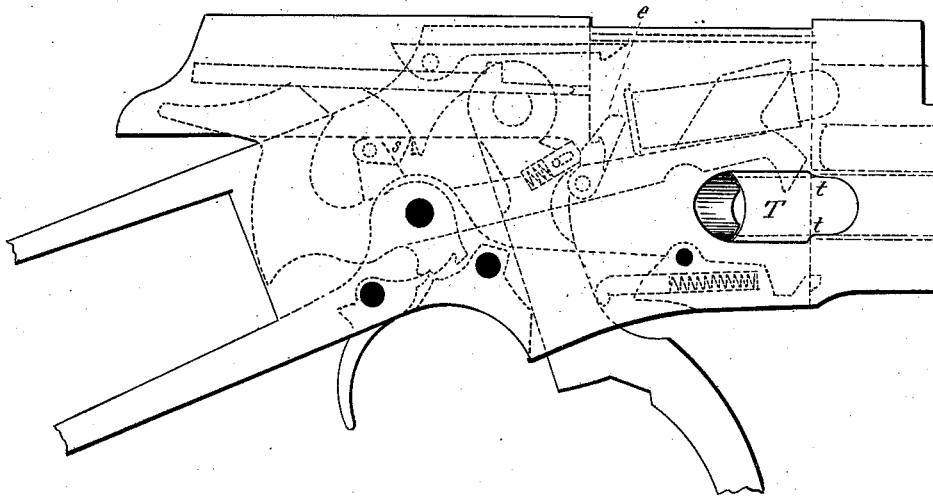

*Witnesses.*  
*Vinton Coombs*  
*A. J. Coombs*

*Inventor.*  
*Andrew Burgess*

# UNITED STATES PATENT OFFICE.

ANDREW BURGESS, OF OWEGO, NEW YORK.

## IMPROVEMENT IN MAGAZINE FIRE-ARMS.

Specification forming part of Letters Patent No. 216,080, dated June 3, 1879; application filed May 7, 1879.

### *To all whom it may concern:*

Be it known that I, ANDREW BURGESS, of Owego, in the county of Tioga and State of New York, have invented an Improvement in Magazine Fire-Arms, of which the following, in connection with the accompanying drawings, is a specification.

My invention is an improvement on my arm patented April 1, 1879, and numbered 213,866, but may be applied to other magazine fire-arms.

Figure 1 is a sectional elevation of this arm. Fig. 2 is an outside view with the breech open, parts being shown in dotted lines.

Similar letters of reference indicate corresponding parts.

The breech-bolt B is moved and locked by the lever L. Said bolt may have ribs or feathers to run in corresponding grooves in the frame, or the top of the bolt, whether round or squared, will be resisted in its upward tendency by the approaching sides of the top of the frame, and the spring sides *o* of the carrier will be prevented from spreading too far open by the same part of the frame when the carrier rises to its highest position.

I show an improved construction of the side-loading aperture through the frame in Fig. 2.

T is the trap or slide; and *t t* are projections to reduce the width of the front part of the opening, and which also support the slide T, thereby dispensing with the groove farther back which has before been made for said slide to run in, it being so narrow between the approaches or projections *t t* as to obstruct the head of a cartridge, so as to guard against the mistake of loading it into the magazine head first, but will admit the body of the cartridge when thrust in point first, and the head will drop down through the wider part of the opening rearward of said projections.

I also pivot the ejector *e* in a projection be-

low the face of the bolt, as in my Patent No. 210,181, or arrange it to slide as in my application filed November 24, 1877, and now pending. I retain the stud *e'* fixed to the lever—alone or with its spring—to trip said ejector, in lieu of passing through the face of the bolt.

As it is often desirable to arrange magazine-guns to use shorter cartridges, I fix a removable stud, *s*, in the bolt, Fig. 1, or to the arm of the carrier, as shown in Fig. 2, to effect engagement of the bolt and carrier, and thereby raise the carrier before the bolt shall be fully withdrawn. This stud or dog also serves to stop the bolt by the carrier when it shall be raised, and so prevent the full opening of the breech.

It is obvious that the stud *s* may be attached to the bolt, or be fixed or supported in the frame as a slide, without materially affecting its operation.

It will be seen that when the stud or slide *s* and the ejecting-bar *e* are removed the bolt may be drawn back as much farther as the length of the stud *s* before engaging the carrier, and the ejection will be effected by the stud *e'*, as described in my former patent.

Having thus described my invention, what I claim as new, and desire to secure by Letters Patent, is—

1. The combination of the ejector *e*, the bolt, the lever, and a stud or projection on the lever to eject the cartridges, substantially as specified.

2. The removable stop *s*, in combination with the bolt and carrier, as and for the purpose described.

ANDREW BURGESS.

Witnesses:

VINTON COOMBS,  
J. J. COOMBS.