

J. H. CRANSTON.
 Bunter Mechanism for Printing-Machines.
 No. 217,069. Patented July 1, 1879.

Fig. 1.

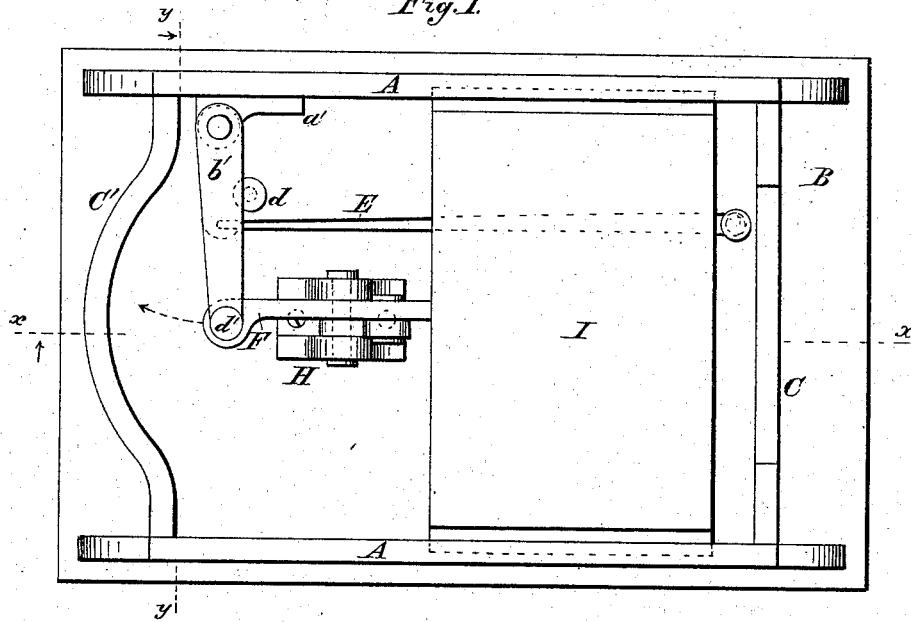

Fig. 2.

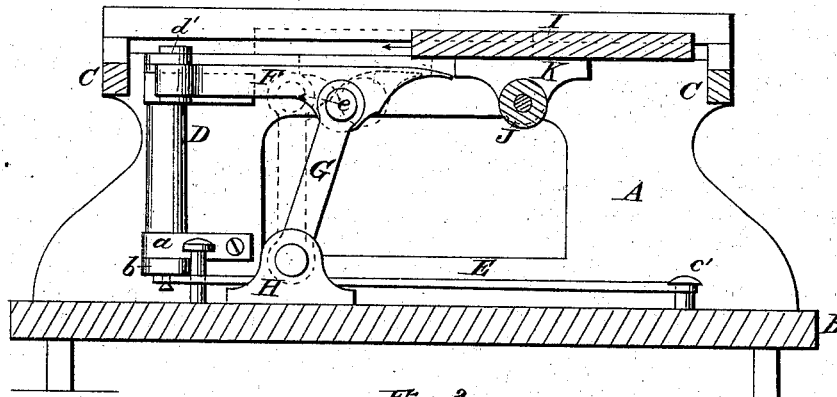
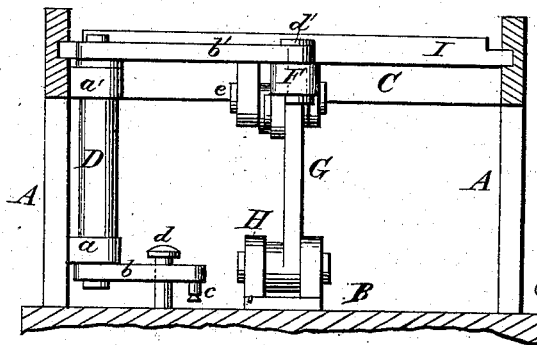

Fig. 3.



Attest:
J. H. Schott.
D. P. Cowe

Inventor:
John H. Cranston
per
J. B. Paskevitch
attys

UNITED STATES PATENT OFFICE.

JOHN H. CRANSTON, OF NORWICH, CONNECTICUT.

IMPROVEMENT IN BUNTER MECHANISMS FOR PRINTING-MACHINES.

Specification forming part of Letters Patent No. **217,069**, dated July 1, 1879; application filed April 3, 1879.

To all whom it may concern:

Be it known that I, JOHN H. CRANSTON, of Norwich, in the county of New London and State of Connecticut, have invented certain new and useful Improvements in Bunter Mechanisms for Printing-Machines; and I do hereby declare the following to be a full, clear, and exact description of the invention, such as will enable others skilled in the art to which it appertains to make and use the same, reference being had to the accompanying drawings and the letters of reference marked thereon, which form a part of this specification.

This invention relates to that part of cylinder printing-machines usually called the "bunter mechanism," which consists of the devices employed for insuring an easy and smooth movement of the reciprocating type-bed or form as the direction of its motion changes at the end of each reciprocation, thus avoiding the concussions and jarring so common in presses of the ordinary construction, which render them difficult to work and liable to get out of repair; and the invention consists in the employment of a vertical rock-shaft provided with two horizontal arms, the lower one of the two being attached to a suitable spring, and the upper one to the devices through which a connection is made at the proper time with the reciprocating type-bed, all as hereinafter fully described.

In the drawings, Figure is a plan of a portion of the press-frame, with the type-bed in such a position as to leave uncovered and show a part of the bunter apparatus. Fig. 2 is a vertical section on the line xx of Fig. 1. Fig. 3 is a transverse section on the line yy of Fig. 1.

The frame of the machine to receive this improved bunter motion is constructed in the ordinary manner, with two cast-metal sides, A, secured to a base, B, the sides being connected and the frame stiffened by suitable girts C and C', placed at the ends of the machine, and the latter having an outward curvature, which gives free play to the upper arm of the rock-shaft D. This rock-shaft occupies a vertical position, and is journaled in the journal-boxes a and a' , which are attached to one of the side frames, A. The bearings of the shaft extend both above and below the

journal-boxes a and a' , carrying upon their ends, and securely attached thereto, the horizontal arms b and b' .

To the outer extremity of the arm b is attached, by means of the pin c or other suitable fastening, a spring, E, the opposite end of which spring is secured to the pin c' or other permanent holding device. This spring E is formed of any suitable material having a proper degree of elasticity, usually of coiled wire. Rubber or even pliable elliptic springs formed of steel plates may be used, if provided with proper connections.

In order to prevent the arm b from being drawn too far inward by the spring, a stop, d , is secured to the base B in such a position as to prevent the arm from passing much farther toward the middle of the press than a right angle to its longitudinal axis.

Attached to the arm b' of the rock-shaft D by the pivot-stud d' is the reciprocating hook F, the free end of which forms a slightly-curved wedge, and is supported by the link G, the lower end of which is pivoted in the link-stand H, secured at the bottom of the frame to the base B. In order that the hook F may have a rectilinear motion the orifice in the end of the arm b' , through which the stud d' passes, is elongated, so that the stud may move outward as the arm swings toward the end of the press, thus allowing the hook to move in a line parallel with that of the type-bed I. This type-bed moves in suitably-constructed ways or tracks, forming a part of or attached to the frame of the press, its reciprocation being produced by the ordinary means employed for that purpose, the novelty in its construction being in the bunter-roll J, which is attached to its under side by means of the brackets K and bearing-pin e .

It will be seen that when the type-bed approaches the end of its movement the roll J will catch the hook F, carrying it toward the end of the press. This movement of the hook will carry back the arm b' and partially rotate the rock-shaft D, which, in turn, acts upon the spring E through the arm b , thus causing a restraining power to act upon the type-bed, and which reaches its maximum at the instant the type-bed reaches the end of its movement in either direction, as, although but

one bunter apparatus has been shown and described, they are needed and are applied at both ends of the press, where they not only relieve the shock caused by bringing the type-bed to a stand-still, but assist in starting it in the opposite direction.

I am aware that devices intended for accomplishing the result aimed at by me in the apparatus hereinbefore described have been constructed; but from a want of proper proportions and a practical arrangement of the parts composing them they have hitherto failed in efficiently accomplishing the object sought.

Having thus described my invention, I claim as new, and desire to secure by Letters Patent, the following:

1. The vertical rock-shaft provided with the horizontal arms, in combination with the hook

F, spring E, and pivoted link G, as and for the purpose specified.

2. The rock-shaft, its arms *b b'*, spring E, and stud *d*, in combination with the hook F, pivoted link G, bunter-roll J, and type-bed, as and for the purpose described.

3. The hook F, provided with the slightly-curved wedge-shaped extremity, supported by and in combination with the pivoted link G and rock-shaft arm *b'*, as set forth.

In testimony that I claim the foregoing I have hereunto set my hand this 25th day of March, 1879.

JOHN H. CRANSTON.

Witnesses:

LUCIUS BROWN,
CHARLES E. DYER.