

H. A. KIMBALL. Button-Carving Machine.

No. 217,949.

Patented July 29, 1879.

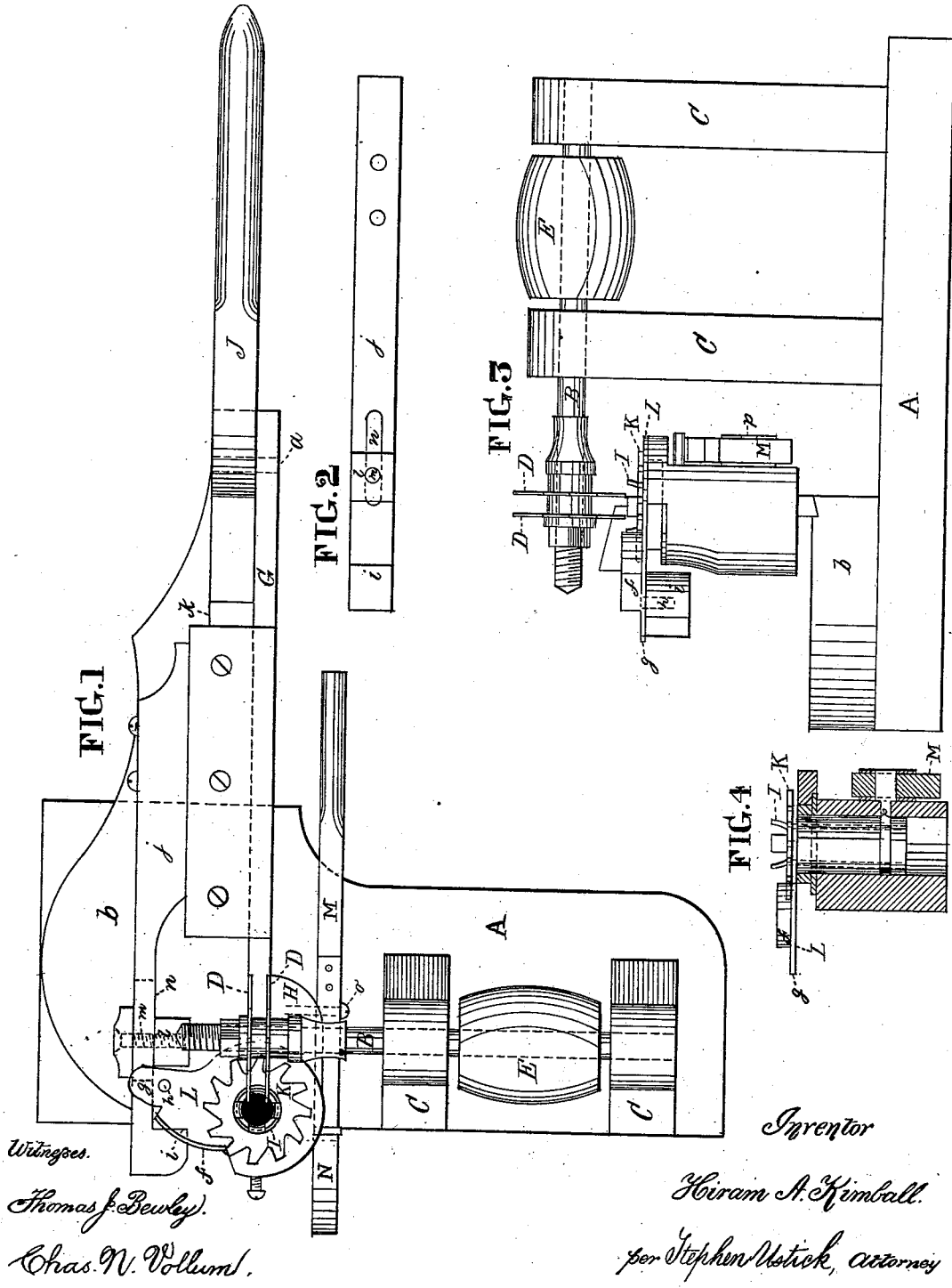

Witnesses.
Thomas J. Dewley.
Chas. W. Vollum.

Inventor
Hiram A. Kimball.
per Stephen H. Stick, attorney

H. A. KIMBALL.
Button-Carving Machine.

No. 217,949.

Patented July 29, 1879.

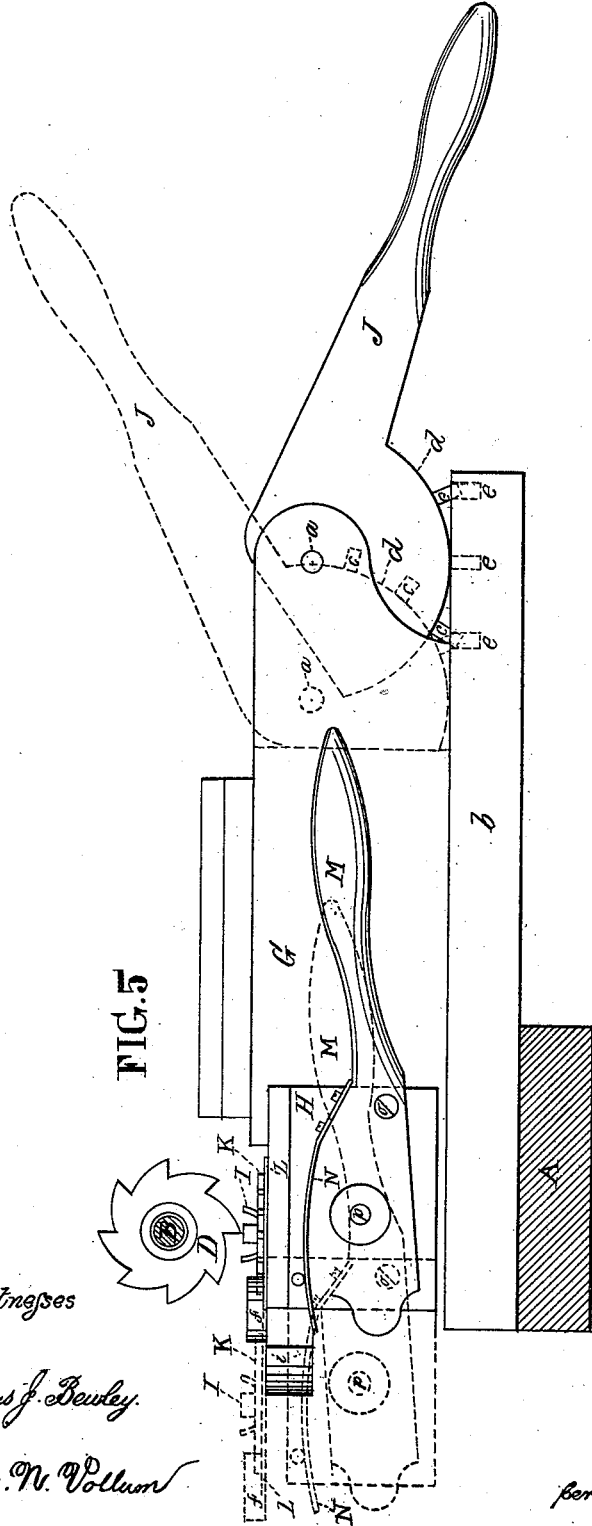

FIG. 5

Witnesses

Thomas J. Bewley

Chas. W. Pollard

Inventor.

Hiram A. Kimball.

per Stephen A. Ustick attorney

UNITED STATES PATENT OFFICE.

HIRAM A. KIMBALL, OF PHILADELPHIA, PENNSYLVANIA, ASSIGNOR TO
GAY, KIMBALL & GAY, OF GAYSVILLE, VERMONT.

IMPROVEMENT IN BUTTON-CARVING MACHINES.

Specification forming part of Letters Patent No. **217,949**, dated July 29, 1879; application filed
May 22, 1879.

To all whom it may concern:

Be it known that I, HIRAM A. KIMBALL, of the city and county of Philadelphia, in the State of Pennsylvania, have invented a new and useful Improvement in Automatic Button-Carving Machines, of which the following is a specification.

My invention consists in the combination of a button-holding chuck, designing-ratchet, and devices for operating them to give an intermittent rotary movement, and also a rectilinear movement, to the chuck, for the purposes and in the manner hereinafter fully described.

In the accompanying drawings, which make a part of this specification, Figure 1 is a plan view of my machine. Fig. 2 is a side view of the strip *j*, for regulating the intermittent rotary movement of the ratchet-wheel for operating the chuck I. Fig. 3 is an end elevation of the machine. Fig. 4 is a vertical section of the chuck-holder H at the broken line *xx* of Fig. 1. Fig. 5 is a side elevation of the machine, partly in section, at the broken line *yy* of Fig. 1.

Like letters of reference in all the figures indicate the same parts.

A represents the bed-plate of the machine. B is a revolving shaft, which is supported by means of the standards C C. It is provided with circular cutters D D, for carving the buttons, and with a driving-pulley, E. G is a slide, to the front end of which is secured the holder H of the chuck I, and to its rear end is pivoted the lever J, for operating it to give a reciprocating movement to the chuck and parts attached thereto, for bringing them beneath the shaping-cutter D D when the work is to be operated upon, and removing them therefrom for changing the position of the chuck.

The lever J is hung on the fulcrum-pin *a*, which projects from the side of the slide G, and has a geared connection with the plate *b* (which forms the lower way for the slide) by means of the pins *c*, which project radially from the concentric curve *d* of the lever, and the depressions *e* in the rear end of the plate *b*, so that by the elevations and depressions of the handle of the lever a reciprocating movement is given to the slide to carry the work under the carving-wheels, to be operated upon and then removed therefrom.

Permanently connected with the upper end of the chuck I is the designing ratchet-wheel K, and beneath the wheel the plate L, which has a free movement on the chuck. This plate is provided with the spring-pawl *f*, which engages with the teeth of the wheel.

Projecting downward from the arm *g* of the plate is the pin *h*, which alternately engages with the permanent shoulder *i* of the horizontal strip *j* (that is confined to the vertical plate *k*) and the lug *l*, that is adjustable by means of the set-screw *m* and slot *n*. (More clearly seen in Fig. 2.)

By this connection the chuck and ratchet-wheel have variable movements given to them, as may be desired, to give variety in the carving of the buttons.

A like effect may be produced by having different ratchets with different numbers of teeth, and any variety of carving may be produced to show different designs by having carving-wheels of different patterns.

In Fig. 1 the chuck I and ratchet-wheel K are represented a short distance in front of the carving-wheels by full lines, and in Fig. 5 at their farthest removed position by dotted lines; and in full lines they are shown beneath the carving-cutters—the position they assume when the cutters are in operation.

M is a lever, hung on the fulcrum-pin *o*, which projects from the side of the chuck-holder H. It has a pivotal connection by means of the pin *p* with the chuck I, so that by the pressing down of the handle of the lever the chuck is elevated to bring the work up to the cutters.

When the chuck is to be lowered to remove the work from the cutters, the hand is removed from the lever, and the spring N forces its lower end downward into the position shown in Fig. 5.

I claim as my invention—

The combination of the plate L, having a pawl, *f*, and pin *h*, with the chuck I, ratchet-wheel K, and stops *i* and *l*, or their equivalents, substantially as and for the purpose set forth.

HIRAM A. KIMBALL.

Witnesses:

E. B. KIMBALL,
NELSON GAY.