

(No Model.)

S. WOODHEAD.

MACHINE FOR SEAMING SHEET METAL ROOFS.

No. 259,786.

Patented June 20, 1882.

Fig. 1.

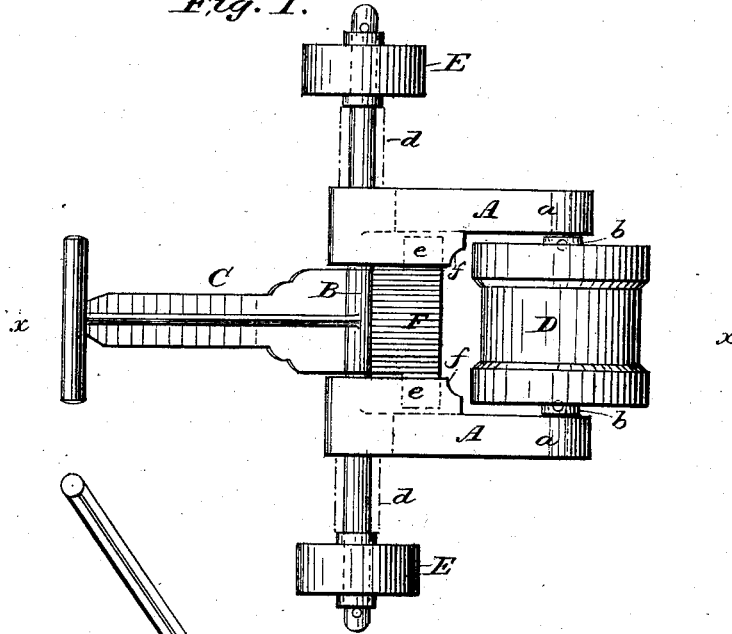

Fig. 2.

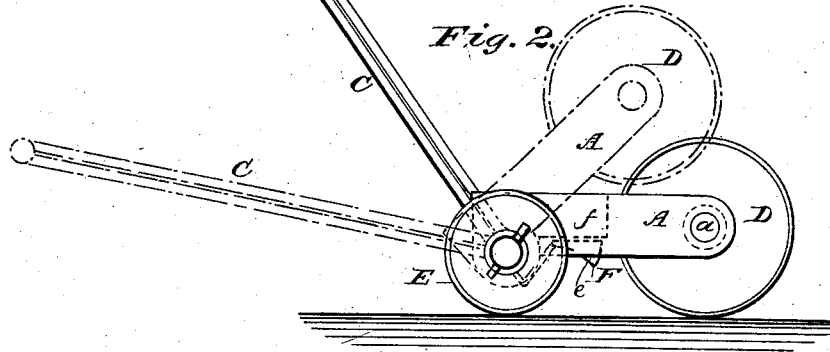
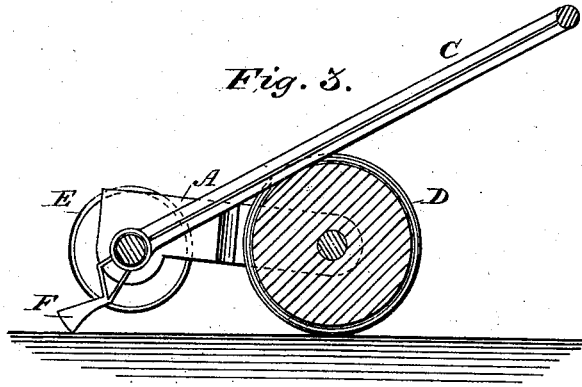

Fig. 3.



WITNESSES
J. C. Brecht
S. F. Deleher.

INVENTOR
Samuel Woodhead,
By Spencer W. Tuttle
Attorney

UNITED STATES PATENT OFFICE.

SAMUEL WOODHEAD, OF WEST TROY, NEW YORK.

MACHINE FOR SEAMING SHEET-METAL ROOFS.

SPECIFICATION forming part of Letters Patent No. 259,786, dated June 20, 1882,

Application filed May 15, 1882. (No model.)

To all whom it may concern:

Be it known that I, SAMUEL WOODHEAD, a citizen of the United States, residing at West Troy, Albany county, State of New York, have invented new and useful Improvements in Machines for Seaming Metal Roofs, of which the following is a specification.

My invention relates to certain new and useful improvements in machines for closing seams in sheet-metal roofs preparatory to soldering down the same, and more particularly to the machine shown and described in Letters Patent No. 233,828, granted to me October 6, 1880, to which I refer for a full understanding of the same.

The object of my present invention is to simplify and perfect the construction of the patented machine; and with these ends in view my invention consists in the peculiar construction and arrangement of parts hereinafter fully described and specifically claimed.

In the construction shown in the patent above referred to, the seam-closing wheels are journaled directly to the weight which constitutes the body of the machine, which weight is necessarily to be supported by the axle and handle when the machine is being transported as well as when in actual use, and the removal of the wheels for adjustment is only accomplished after turning the machine on its back, as will be understood by reference to said patent. In my present machine these difficulties are all overcome and many advantages not existing in the patented machine are acquired.

To enable those skilled to fully understand my invention, I will proceed to describe the same in detail, referring by letters to the accompanying drawings, in which—

Figure 1 is a top or plan view of a machine embodying my invention. Fig. 2 is a side elevation of the same, the dotted lines showing the position of the machine when in use; and Fig. 3 is a longitudinal vertical section taken at the line *x x* of Fig. 1, and with the handle thrown back into the position necessary to lift the "seaming-wheels" for the purpose of removal or adjustment.

Similar letters indicate like parts in the several figures.

A A represent the side frames or body of the machine, to which the axle B is secured in any suitable manner. These frames are sepa-

rated, as shown, so as to receive between them the handle C and weight-roller D. The handle is pivotally connected to the axle, as clearly seen at Fig. 3, and the weighted roller is provided with short trunnions *a a* (seen in the dotted lines, Fig. 1) and collars *b*. The trunnions have their bearings in the rear ends of their frames A A and rotate freely therein.

E E are the seaming-rolls, arranged upon the axle B, the dotted lines seen at *d d* representing adjusting-collars, which are placed between the rolls and the frame of the machine, as illustrated, or between the wheels and the linchpins when the wheels are placed against the body of the machine, to decrease the distance between them. The object of such adjustment is fully described in my Letters Patent hereinbefore referred to.

The handle C is provided with a rear extension, F, of a length slightly greater than the height of the axle B from the ground, so that when the handle is thrown rearward, as shown at Fig. 3, the axle B serving as a fulcrum, the rolls E E will be lifted and readily removed or adjusted. The handle, when in this position, is supported, as clearly seen, by contact with the weighted roll D. The extension F of the handle is formed with lateral wings or projections, (seen in dotted lines *e e*, Fig. 1,) which are adapted to come in contact with and bear against shoulders *f f* on the inside of frames A A, (see Figs. 1 and 2,) so that when the forward end of the handle C is depressed, the weighted roller D and frames A A will be lifted, the axle B serving as a fulcrum, and in this way the strength of the operator and the weight of the roller D combine to produce the necessary pressure of the seaming-rolls E E upon the seam to be closed.

The handle C may be so applied to the axle as to be readily removable therefrom, and the roller D, instead of being framed with the trunnions and collars, as shown, may be secured in place by a removable axle passing through the same and the frames A A, and thus be adapted for removal from the machine.

It will be observed that the roller D serves as a combined support, with the rolls E E, for the frame of the machine when the same is being transported from point to point on the roof, and is not a dead-weight, as is the case in

the machine forming the subject of my patent referred to.

What I claim as new, and desire to secure by Letters Patent, is—

- 5 1. In combination with theseaming-rollers E and axle B, the side frames, A, and weighted roller D, adapted to be lifted or vibrated upon the axle B, substantially as and for the purpose set forth.
- 10 2. In combination with the rolls E, frames A, and weighted roller D, the handle C, pivoted to the axle and formed with the extension F, adapted to support the rolls E in an elevated position, as and for the purpose set forth.

3. The side frames, A, formed with the 15 shoulders *ff*, in combination with the handle C, pivoted to the axle B and provided with lateral wings *ee*, substantially as and for the purpose set forth.

In testimony whereof I have hereunto set 20 my hand and seal in the presence of two subscribing witnesses.

SAML. WOODHEAD. [L. S.]

Witnesses:

A. T. PHELPS,
E. S. HOLLANDS.