

G. O. S. CONWAY.

CAR BRAKE.

No. 302,651.

Patented July 29, 1884.

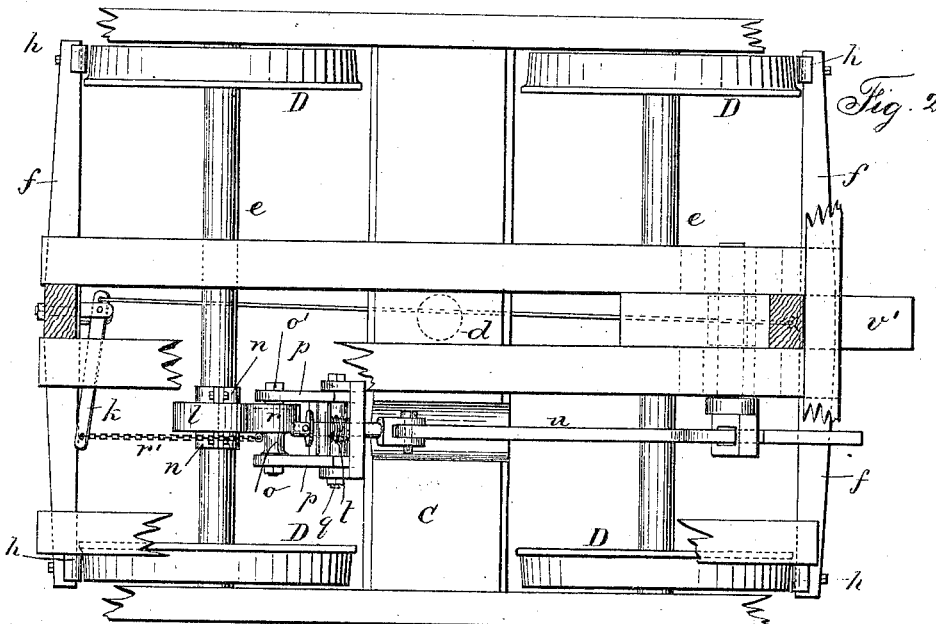
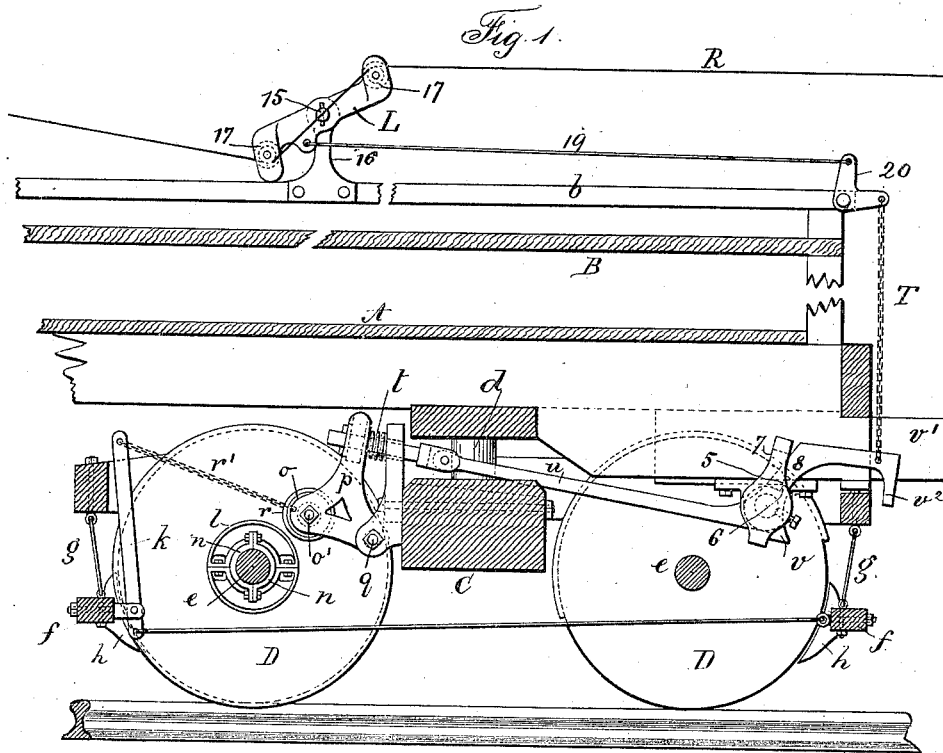

Witnesses  
 I Staib  
 Chas. H. Smith

Inventor:  
 George O. S. Conway  
 per Linnell W. Ferrell atty

(No Model.)

2 Sheets—Sheet 2.

G. O. S. CONWAY.  
CAR BRAKE.

No. 302,651.

Patented July 29, 1884.

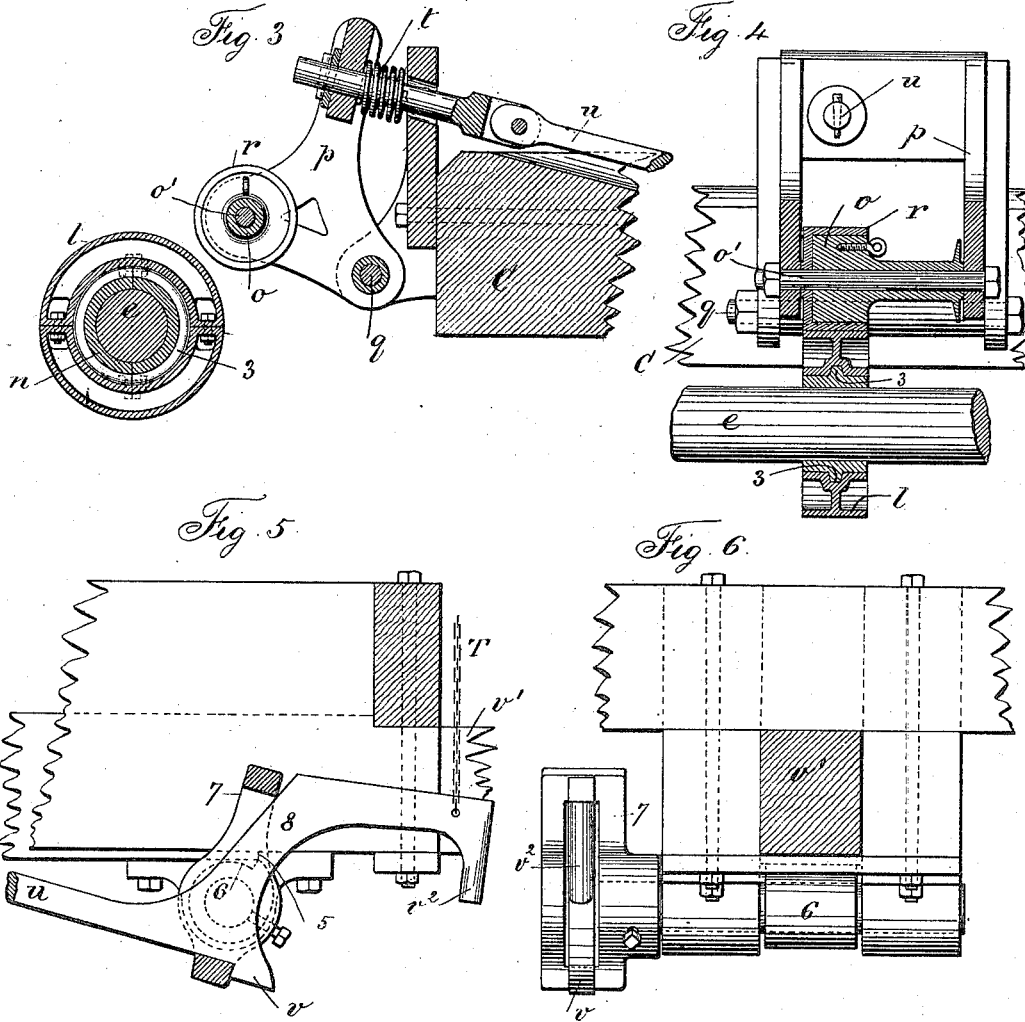

Witnesses:  
J. Staib  
Chas. H. Smith

Inventor  
George O. S. Conway  
per Lemuel W. Serrell atty

# UNITED STATES PATENT OFFICE.

GEORGE O. S. CONWAY, OF STONEFIELD, QUEBEC, ASSIGNOR TO HIMSELF,  
AND FREDERICK FAIRMAN AND JAMES COOPER, BOTH OF MONTREAL,  
CANADA.

## CAR-BRAKE.

SPECIFICATION forming part of Letters Patent No. 302,651, dated July 29, 1884.

Application filed March 5, 1884. (No model.)

*To all whom it may concern:*

Be it known that I, GEORGE O. S. CONWAY, of Stonefield, in the Province of Quebec, Dominion of Canada, have invented an Improvement in Railway-Car Brakes, of which the following is a specification.

This invention is specially intended for freight-cars, and it is partially automatic. When the brake-rope is pulled, the brake mechanism is applied, and the revolution of the wheels is made to wind up the brake-chain and apply the brakes, the intervening wheels and devices being operated by friction, so that there is no rigid connections, and the parts will slide, one on the other, after the proper pressure is given to the brakes. I also make use of a latching device that is operated by the draft head or bar, and acts to disconnect the brake when the train is drawn ahead. By this arrangement the control of a freight-train is in the hands of the engineer almost as effectually as the air-brakes made use of in passenger-trains.

It is to be understood that my invention is not limited to freight-trains.

In the drawings, Figure 1 is a side view of the apparatus, the truck being partially in section. Fig. 2 is a plan view with parts of the truck removed or broken open. Figs. 3 and 4 show sections of the winding-barrel and friction-wheel. Fig. 5 is a side view, partially in section, of the latching device; and Fig. 6 is an end view of the same and the draw-bar and roller.

The body of the car is of any desired character, a portion only being shown, A being a part of the platform, and B a part of the top of the car upon which the usual walk or board, b, is applied. The truck-frame is composed of the cross-bearer c, with a king-bolt, d. The side frames and hangers are of any desired character. The wheels D are connected by the axles e, and the brake-bars f are hung by the links g, and provided with shoes h, and the lever k pivoted upon one of the bars f, and connected by a rod or chain with the other box. These parts may be of any desired character. Upon one of the axles e there is a fric-

tion-wheel, l. This, for convenience, will usually be made in two parts bolted together, as shown, so that they may be applied to the axle without removing the wheels D. Around the axle there are also rings or sleeves n n, which preferably are made in halves and bolted together. They clamp the axle tightly, so as to prevent motion to the wheel l endwise of the axle. This wheel l is free to turn either upon the axle itself or upon a sleeve surrounding the axle and passing into the wheel l. I prefer to make the sleeve n in the form shown sectionally in Figs. 3 and 4, wherein the sleeve is made with a central ring, 3, and the wheel l is recessed around the inner surface, so as to set over this ring 3. The winding-drum o is upon an axle, o', sustained by the triangular or lever frames p. These frames are pivoted at q on a support bolted to the central bearer of the truck-frame. Upon one end of the drum there is a loose pulley or wheel, r. The wire rope or chain r' from the brake-lever k is fastened to an eye upon this drum o.

The size and shape of the parts are such that in the normal position the drum o and frame p are swung up, so that the wheels l and r do not touch each other; hence the wheel l revolves with the axle e without loss of power; but when the frames p are swung upon the pivots q the wheel r is brought (either from below or from above) into contact with the wheel l, and there will be a sufficiently forceful action to create a friction of the loose wheels upon the sleeves or axles and of the wheels with each other at the points of contact, so that the drum or winch o will be revolved with the necessary force, and this revolving-power, being derived from frictional contact, is not a positive rotary motion, but, on the contrary, one that will yield, and hence there will be no risk of breakage. I remark that the wheels l and r might have teeth in their surfaces, as they will only act by friction to revolve the drum o; but I prefer that frictional contact of the surfaces only be employed.

The power which acts to swing the frame p and force the wheels l and r into contact is a spring. I prefer the expansive spring t, placed

between the upper end of the lever-frame *p* and support on the bearer of the truck. I employ a link, *u*, connected at one end to the lever-frame *p*, and at the other end said link is provided with the latch-piece *v*. The draft head and bar *v'* is free to move endwise a limited distance, as usual. Upon its under side is a downward projection, 5, and beneath the draw-bar is a roller, 6, with a notch or toe upon its upper surface. When the train is drawn ahead the roller is partially rotated by the projection 5 coming into contact with the toe on the upper surface of the roller, and there is an arm, 7, projecting from the roller and acting against the arm 8 at the end of the link *u*, to draw back such link *u*, and compress the spring *t*, and separate the wheels *l* and *r*, and liberate the brake. This done, the latch *v* drops and holds the parts so that the brake will not be applied by the ordinary movements of the train, either in going ahead, backing, or stopping. This latch *v* may be raised by hand, there being a handle, *v*<sup>2</sup>, upon the lever end of the link *u*, by which the parts may be lifted, so as to disengage the latch *v* and allow the brake mechanism to assume a position which causes the brakes to be applied if the car is moved in either direction.

In order to place the control of the brakes in the charge of the engineer or conductor, I make use of a brake-rope, *R*, passing from end to end of the train, preferably over the cars, and the same is made to operate the chain or bar *T*, and lift the latch *v*, and allow the brakes to operate. Any suitable device may intervene between this brake-rope *R* and the chain *T*. I prefer to use a lever, *L*, pivoted at 15 to a standard, 16, at the side of the board walk *b*, and near the ends of this lever there are rollers or sheaves 17 and guide-eyes. The rope *R* passes over and under these respective sheaves, and is held in place by the guide-eyes. The normal position of this lever *L* is vertical, or nearly so, and it is caused to assume that position by a weight or spring. There is a chain,

or preferably a bar, 19, from the lever *L* to a bent lever, 20, to which the upper end of the chain *T* is attached. When the brake-rope is drawn upon with sufficient force, it tends to assume a straight line; and in so doing it swings the levers *J* of the respective cars into inclined positions, and, drawing upon the rods and chains, unlatches the connecting-rods *u* of each brake apparatus and allows the springs to act in applying the brakes, as aforesaid.

I claim as my invention—

1. The wheels and axles *e* and the brakes, levers, and rods, in combination with the wheel *l* upon the axle *e*, the lever *p*, pivoted to the truck-frame, the friction-wheel *r* and winding-drum supported upon such frame, the chain *r'* to the winding-drum, the latch-rod *u*, spring *t*, and lever *v*<sup>2</sup>, substantially as set forth.

2. The drum *o* and loose pulley or wheel *r* around the end thereof, and the triangular pivoted frame, in combination with the wheel *l* and axle *e*, upon which such wheel *l* is free to turn, the brake, levers, and rods, and the connection to the drum, substantially as specified.

3. The combination, with the latch and link, and the lever, winch-barrel, and brake mechanism, of the draw-bar, a turning roller acted upon by the draw-bar, and an arm to move the link, and a latch to relieve the brake mechanism when the train is drawn ahead, substantially as set forth.

4. The combination, with the brake-rope, of a lever pivoted to a standard, and provided with sheaves and guides at the ends for the brake-rope, a connection, *r*, the latch-rod *u*, spring *t*, lever *p*, winding-drum *o*, friction-wheels *l* *r*, brake-blocks, levers, and connections, substantially as specified.

Signed by me this 23d day of February, A. D. 1884.

G. O. S. CONWAY.

Witnesses:

GEO. T. PINCKNEY,  
WILLIAM G. MOTT.