

(No Model.)

3 Sheets—Sheet 1.

W. BODGE.

CYLINDER PRINTING MACHINE.

No. 303,697.

Patented Aug. 19, 1884.

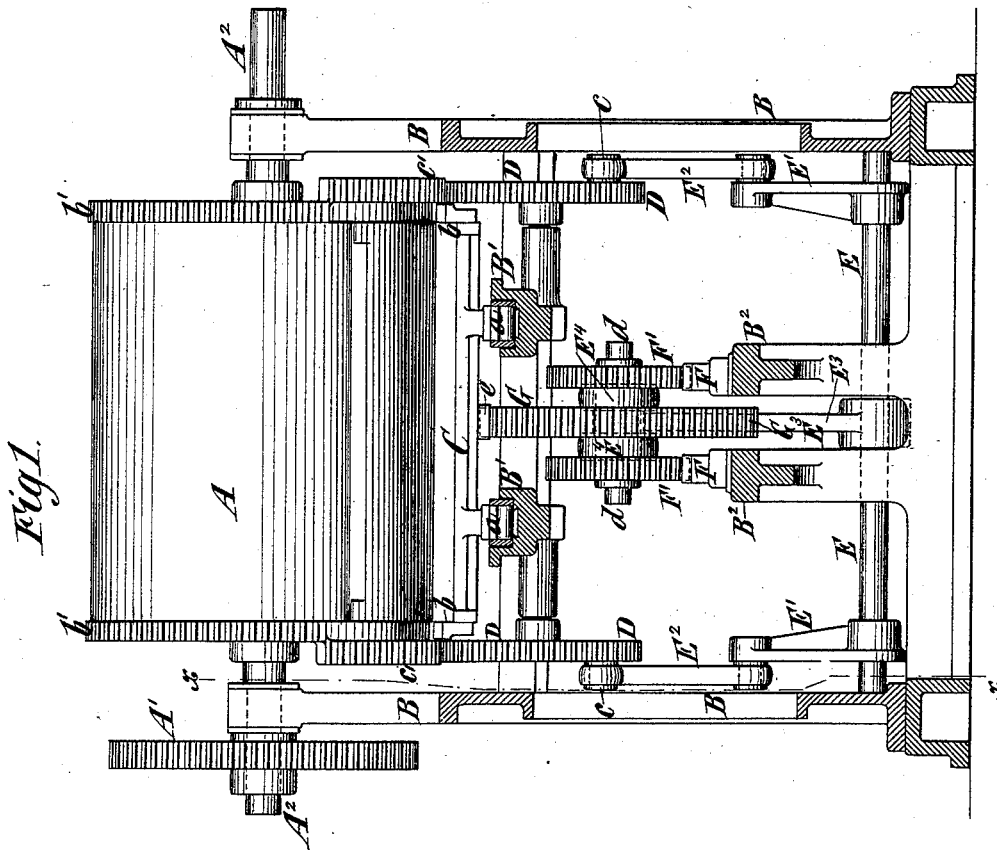

Fig. 1.

Witnesses:  
Ed. L. Morin  
Mat. Pollock

Inventor:  
William Bodge  
by his Attorneys  
Brown & Hall

W. BODGE.

CYLINDER PRINTING MACHINE.

No. 303,697.

Patented Aug. 19, 1884.

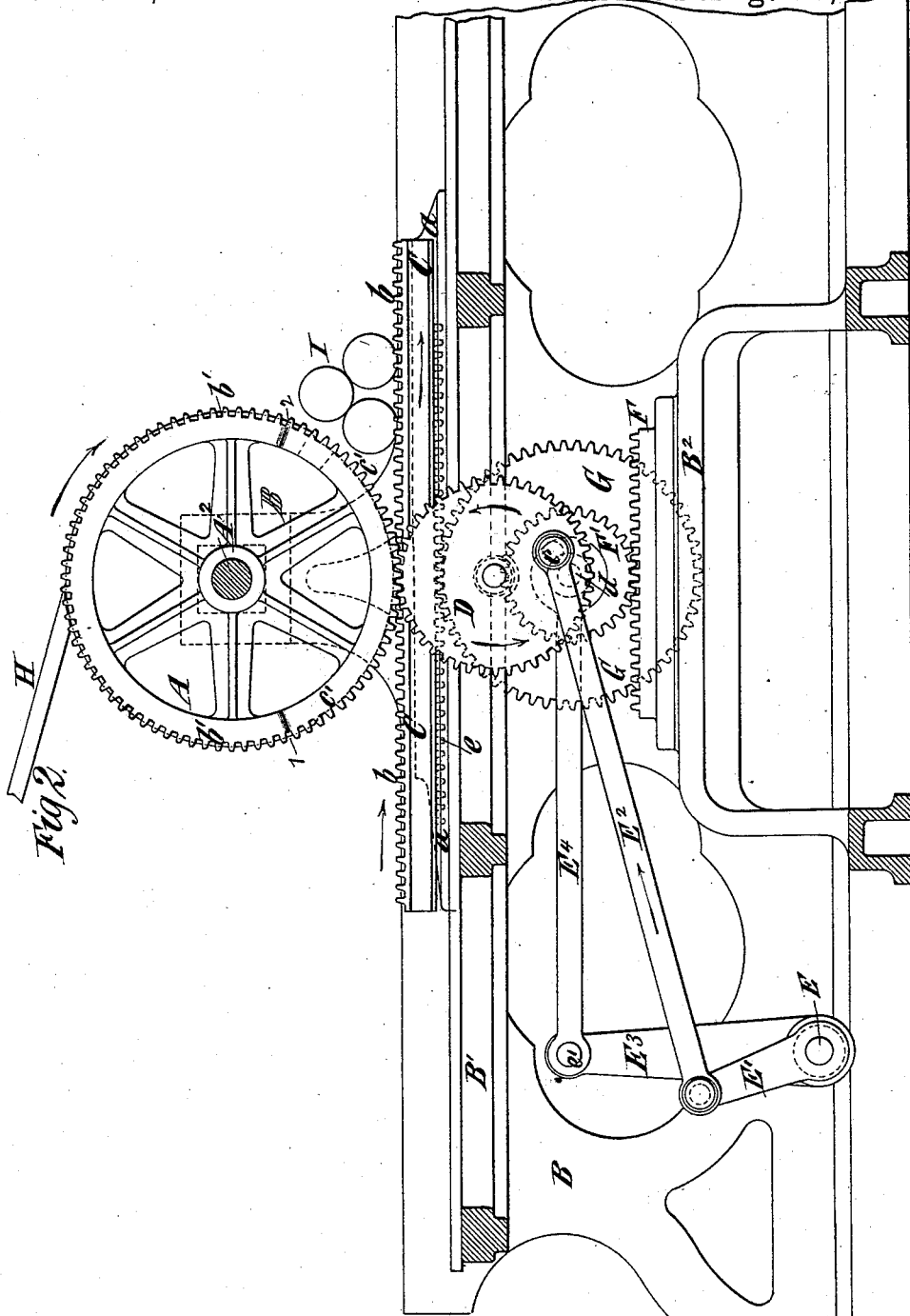

Witnesses:

Ed. L. Moran  
Mat Pollock

Inventor:

William Bodge  
by his Attorneys  
Brown & Hall

W. BODGE.

CYLINDER PRINTING MACHINE.

No. 303,697.

Patented Aug. 19, 1884.

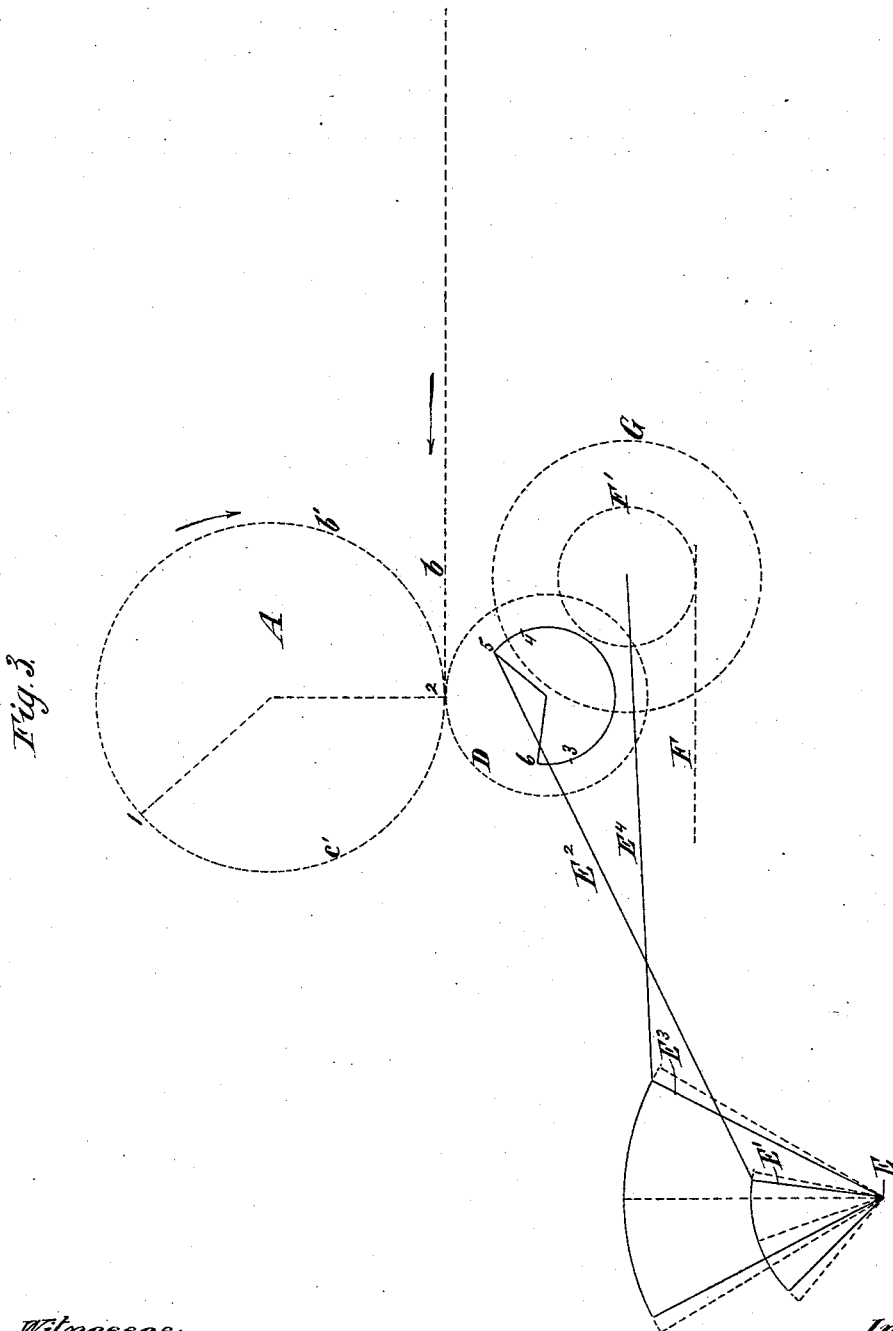

Fig. 3.

Witnesses:  
 Ed. L. Moran  
 Mat Pollock

Inventor:  
 William Bodge  
 by his Attorneys  
 Brown & Hall

# UNITED STATES PATENT OFFICE.

WILLIAM BODGE, OF BROOKLYN, NEW YORK, ASSIGNOR TO CALVERT  
B. COTTRELL, OF STONINGTON, CONNECTICUT.

## CYLINDER PRINTING-MACHINE.

SPECIFICATION forming part of Letters Patent No. 303,697, dated August 19, 1884.

Application filed January 7, 1884. (No model.)

To all whom it may concern:

Be it known that I, WILLIAM BODGE, of the city of Brooklyn, in the county of Kings and State of New York, have invented a new and useful Improvement in Cylinder Printing-Machines, of which the following is a specification.

My invention is applicable to printing-presses in which a continuously-rotating impression-cylinder makes one complete revolution at each back and forward movement or double stroke of the bed. In such a press the bed is operated directly from the cylinder during printing by means of segment-gears on the cylinder engaging with racks on the bed, and the return movement of the bed at an accelerated speed is accomplished by means of a crank operated by the cylinder and gearing and other devices connecting said crank with the bed.

My invention consists in the combination, with a continuously-rotating impression-cylinder and a bed, of gearing through which the bed is moved directly by the cylinder during printing, a crank operated by the cylinder, and mechanism, substantially such as hereinafter particularly described, through which the bed is actuated at the commencement and completion of its forward movement for printing, and through which the bed is driven at an accelerated speed during its entire return movement.

In the accompanying drawings, Figure 1 is a transverse vertical section of a press embodying my invention. Fig. 2 is a longitudinal section on the plane of the dotted line  $xx$ , Fig. 1, and Fig. 3 is a diagram illustrating the relative position of parts; and hereinafter described.

A designates the cylinder of the press, to which a continuous rotary movement is imparted through the gear-wheel  $A'$ , fixed on its shaft  $A^2$  from any suitable mechanism. The cylinder-bearings are mounted in the side frames, B, of the press, and the arrow, Fig. 2, indicates the direction of rotation of the cylinder.

C designates the bed, which is reciprocated upon the usual guideways or bearers,  $B'$ , which extend from end to end of the press, shoes or roller-bearings  $a$  being interposed between the

bed and said guideways or bearers, as shown in Fig. 1.

The bed C is provided at opposite sides with longitudinal racks  $bb$ , and at opposite ends the cylinder is provided with arcs of spur-gearing  $b' b'$ , which range vertically with the racks  $b b$  on the bed C, but which are not continuous around the circumference of the cylinder.

D D designate spur-gear wheels, which are adapted to rotate on studs projecting from the guideways or bearers  $B'$ , as best shown in Fig. 1, and in which are fixed crank or wrist pins  $c$ .

At the ends of the cylinder A and beyond or outside of the arcs of gearing  $b'$  are other arcs of gearing  $c'$ , which range vertically with the crank-wheels D, and are adapted to engage therewith during a portion of the rotation of the cylinder. The arcs of gearing  $c'$  are not continuous around the cylinder, but each arc  $c'$  in connection with one of the arcs  $b'$  encircles the cylinder, as shown in Fig. 2. The pitch-line of the two arcs  $c' b'$  is the same, and is coincident with the circumference of the cylinder A. By the continuous rotation of the cylinder the arcs  $b'$  are brought into gear with the racks  $b$  on the bed, and during their engagement they impart motion to the bed by direct gearing. As the arcs  $b'$  leave the racks  $b$  the arcs  $c'$  come into gear with the crank-wheels D, and through suitable mechanism, now to be described, impart the return or backward movement to the bed C.

E designates a rock-shaft, having at opposite ends arms  $E'$ , which are connected by rods  $E^2$  with the crank pins or wrists  $c$ , as shown in Figs. 1 and 2.

Below the bed C are two stationary racks, F F, extending parallel with each other and lengthwise of the press; and  $F' F'$  are two spur-wheels, which gear into and travel along said racks, and which support a short shaft or axle,  $d$ .

On the shaft or axle  $d'$ , between the wheels  $F'$ , is a larger spur-wheel, G, which engages with a rack,  $e$ , on the under side of the bed C, as best shown in Fig. 1, and depends or drops down between the bearers  $B^2$ , on which the parallel racks F are supported.

Upon the rock-shaft E, about midway of its length, is an arm,  $E^3$ , which is longer than the

arms E', and from which a connecting-rod, E<sup>4</sup>, extends to the short shaft *d*, and imparts a reciprocating movement thereto. This connecting-rod may consist of two flat parallel links or bars, which at one end have eyes that loosely embrace the shaft *d* on opposite sides of the wheel G, as shown in Fig. 1, and at the other end receive the arm E<sup>3</sup> between them, and are secured to the arm by a pin, *e*.

10 The wheels F' and G must all be rigidly fixed on the shaft *d*, and as the shaft is moved back and forth by the rod E<sup>4</sup> the wheels F' E' G are moved bodily, and at the same time are rotated by their engagement with the racks F.

15 The combined bodily and rotary movement of the wheels F' would produce an accelerated movement of the bed, even if they themselves engaged with racks on the bed; but inasmuch as the wheel G, which engages with the rack *e* on the bed, is very much larger than the wheels F', the movement of the bed is still further accelerated. For example, if the wheel G be twice the diameter of the wheels F', the movement imparted to the bed by the combination above described will be one and one-half as great as would be the case if the wheels F' geared into racks on the under side of the bed, as well as into the racks F. The cylinder does not produce the whole movement of the bed in the direction for printing, but part is given by the cranks D and the multiplying gearing through which they transmit their motion to the bed. Half a revolution of the cranks is sufficient to produce the full return movement of the bed; but the cranks are operative through about two-thirds of their movement, and the short arcs *e*' on the cylinder should be long enough to produce such movement of the cranks.

40 H designates the feed-board, and 1 2 in Fig. 2 designate the points in the cylinder where the shorter arcs of gearing *e*' begin and end. As represented in Fig. 2, the arcs of gearing *e*' are in engagement with the crank-wheels D, and the cylinder is moving in the direction indicated by the arrow, thereby rotating the crank-wheels in the direction indicated by the arrow thereon. As there shown, the crank-wheels are at the center of the movement and the bed is at mid-stroke, moving in the direction of the arrow thereon. The crank-wheels D, acting through the rods E<sup>2</sup>, arms E' E<sup>3</sup>, rock-shaft E, and rod E<sup>4</sup>, move the gear-wheels F' E' along the racks F, and so produce a very rapid movement of the bed. The movement of the cranks D from the point 3 to 4, Fig. 3, or just a half-revolution, effects the full return-stroke of the bed, and by the movement of the cranks beyond the point 4 to the point 5 the movement of the bed to print is commenced. In the diagram Fig. 3, the long arcs of gearing

*b*' are represented as just engaging with the racks *b* on the bed, and when the cranks reach the point 5 the short arcs of gearing *e*' leave the crank-wheels, and the movement of the bed to print is continued by direct gearing from the cylinder.

Although the speed of movement of the bed produced by the crank-wheels D when the latter are at about the middle of their stroke is greatly in excess of that produced by the direct gearing from the cylinder, it will be understood that at the time the long arcs *b*' take into the racks on the bed the short arcs *e*' have just carried the cranks D over the center, and consequently the bed is moving slowly, and its speed at this time should be equal to that of the cylinder. The crank-wheels D now remain inoperative, and are rotated idly from the point 5 to the point 6 by the bed acting through the wheels G F' and rod E<sup>4</sup> upon the rock-shaft E, and through the arms E' and rods E<sup>2</sup> upon the cranks; but when the cranks D reach the point 6 the short arcs *e*' again engage with them, and by the movement of the cranks from 6 to 3 complete the movement of the bed to print, and by the further movement from 3 to 5 effect the complete return movement of the bed and again start it forward. The crank-wheels D should be vertically adjustable correspondingly to the vertical adjustment of the cylinder. This may be effected in any well-known manner.

In Fig. 2 I have shown an arbitrary illustration of inking-rollers I. These may be of any ordinary or suitable construction and arrangement, and I make no claim to them.

What I claim as my invention, and desire to secure by Letters Patent, is—

1. The combination of the cylinder A, having the long and short arcs of gearing *b*' *e*', the bed C, having racks *b*, the crank-wheels D, the rock-shaft E, and arms E' E<sup>3</sup>, and rods E<sup>2</sup>, connecting said crank-wheels with said arms E', the rod E<sup>4</sup>, receiving motion from the arm E<sup>3</sup>, and gearing operated by said rod E<sup>4</sup>, for transmitting an accelerated return movement to the bed C, substantially as herein specified.

2. The combination of the cylinder A, having arcs of gearing *b*' *e*', the bed C, having racks *b* *e*, the crank-wheels D, the rock-shaft E, and arms E' E<sup>3</sup>, the rods E<sup>2</sup> E<sup>4</sup>, the stationary racks F, the wheels F', engaging with the racks F, the wheel G, engaging with said rack *e*, and the shaft *d*, on which the wheels F' G are fixed, and to which the rod E<sup>4</sup> is connected, all substantially as herein described.

WM. BODGE.

Witnesses:

FREDK. HAYNES,  
ED. L. MORAN.