

O. M. MORSE.
MIDLINGS PURIFIER.

No. 304,225.

Patented Aug. 26, 1884.

Fig. 2

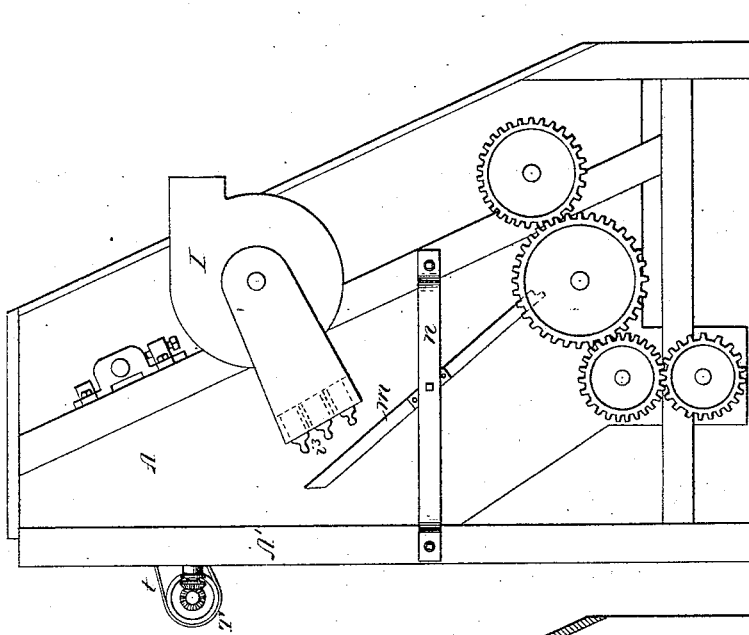
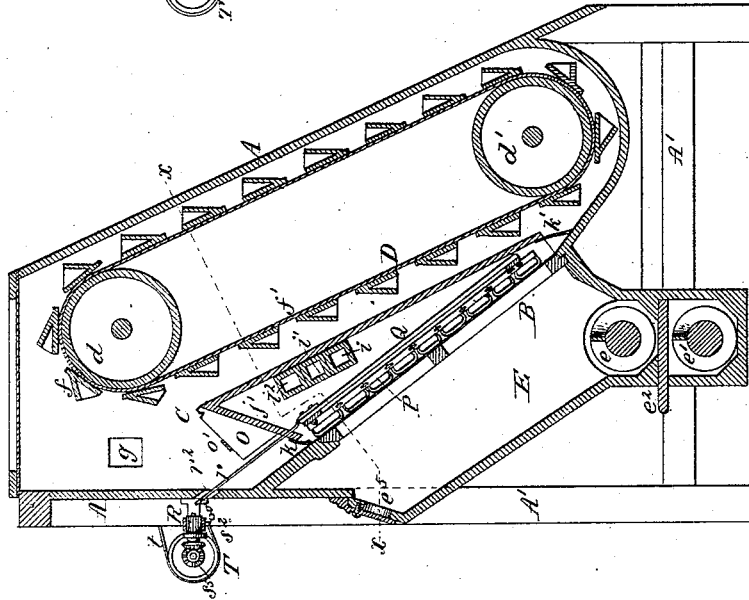

Fig. 1.



Chas. Buchheit
 Theo. L. Popp } Witnesses.

Orville M. Morse Inventor
 By Wilhelm Rimmer
 Attorneys.

O. M. MORSE.
MIDLINGS PURIFIER.

No. 304,225.

Patented Aug. 26, 1884.

Fig. 3.

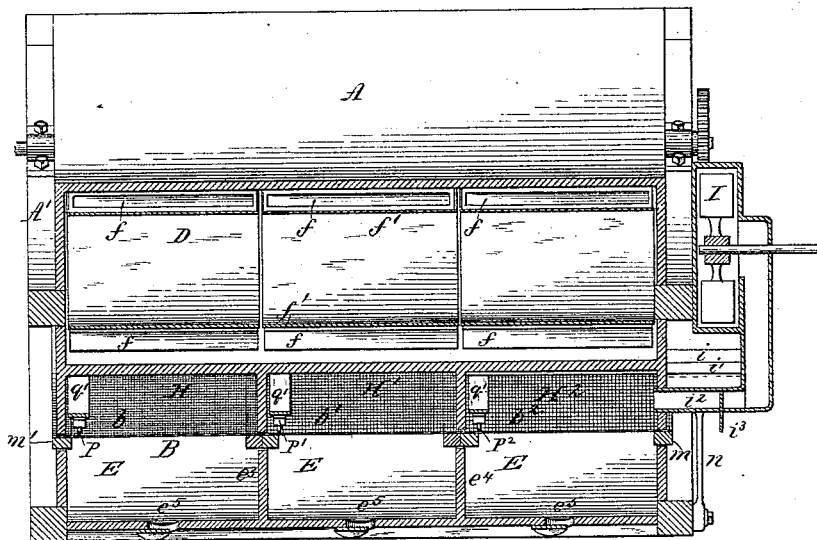
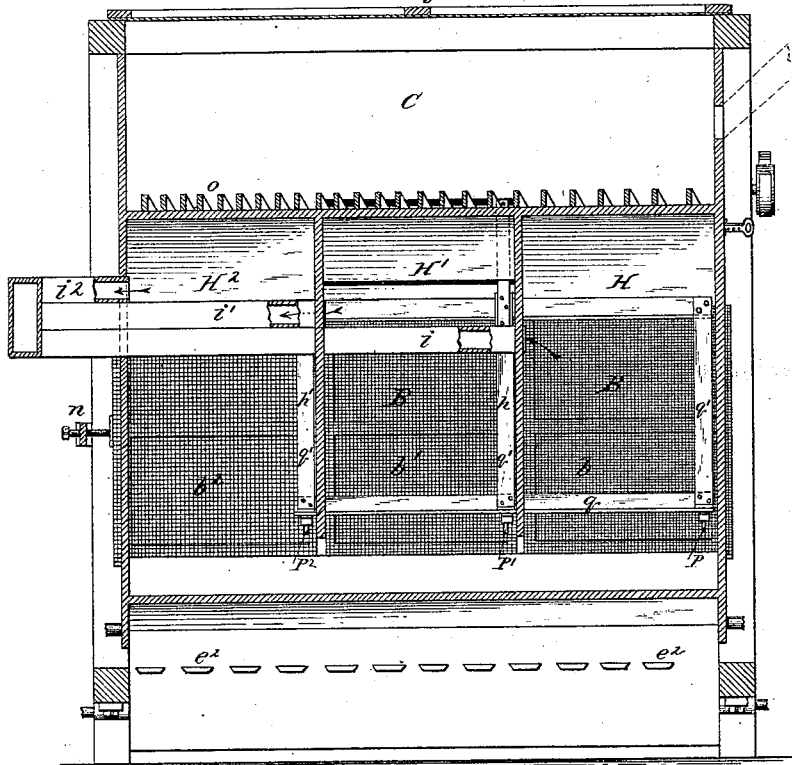

Fig. 4.



Chas. Buchheit
Theo. L. Popp } Witnesses.

Orville M. Morse Inventor.
By Wilhelm Rönner
 Attorneys.

O. M. MORSE.

MIDLINGS PURIFIER.

No. 304,225.

Patented Aug. 26, 1884.

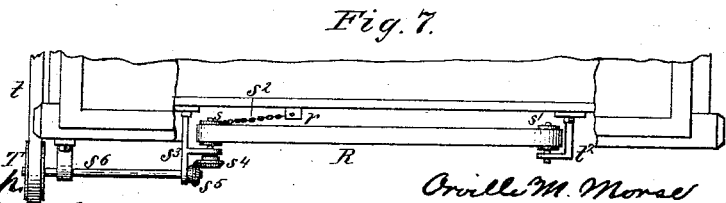
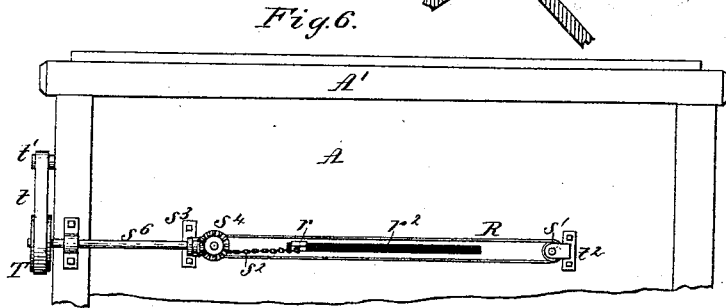
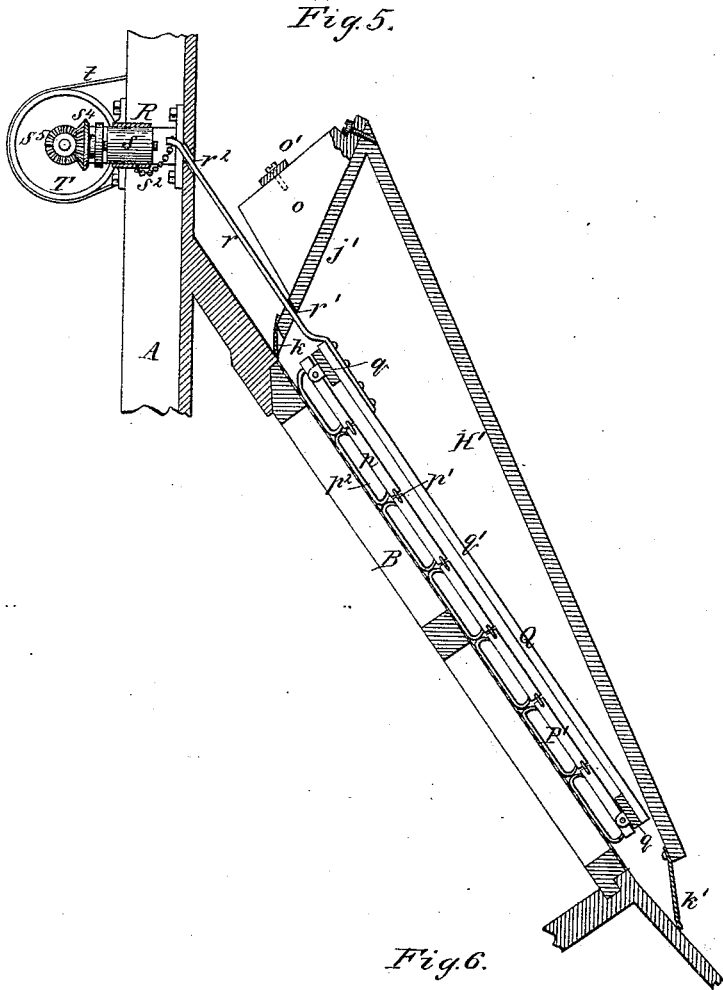

Theo. L. Sopp
Chas. Buchheit
 Witnesses.

Oville M. Morse Inventor.
 By *Wilhelm & Bonni* Attorneys.

UNITED STATES PATENT OFFICE.

ORVILLE M. MORSE, OF JACKSON, MICHIGAN, ASSIGNOR TO THE KNICKERBOCKER COMPANY, OF SAME PLACE.

MIDLINGS-PURIFIER.

SPECIFICATION forming part of Letters Patent No. 304,225, dated August 26, 1884.

Application filed December 12, 1883. (No model.)

To all whom it may concern:

Be it known that I, ORVILLE M. MORSE, of Jackson, in the county of Jackson and State of Michigan, have invented new and useful
5 Improvements in Middlings-Purifiers, of which the following is a specification.

This invention relates to an improvement in that class of bolting or separating machines which are composed of an inclined sieve and
10 an elevating mechanism, whereby the material which has passed over the sieve and escapes from the lower end thereof is elevated and delivered upon the upper end of the sieve, and in which the material is at the same time caused
15 to move gradually across the sieve, so that the material is repeatedly elevated and caused to flow over the inclined sieve in passing through the machine. Apparatus of this character is described and shown in Letters Patent of the
20 United States No. 225,536, dated March 16, 1880, and No. 255,002, dated March 14, 1882, to which reference is here made for a more complete description of the same.

The object of the present invention is to
25 adapt the machine to the purification of middlings by organizing the machine in such manner that currents of varying strength can be directed upwardly through the different sections of the screen, in order to adapt the force
30 and volume of the air-currents to the character of the material passing over the different screen-sections.

My invention consists, to this end, of the improvements in the construction of the machine
35 which will be hereinafter fully set forth, and pointed out in the claims.

In the accompanying drawings, consisting of three sheets, Figure 1 is a vertical cross-section of a machine provided with my improvements. Fig. 2 is an elevation of the tail end
40 of the machine. Fig. 3 is a longitudinal section on line $x x$, Fig. 1. Fig. 4 is a longitudinal sectional elevation of the machine. Fig. 5 is a cross-section on an enlarged scale of the screen and wipers. Fig. 6 is a front elevation
45 of the upper part of the machine. Fig. 7 is a top plan view of the same.

Like letters of reference denote like parts in the several figures.

50 A is the inclosing-case of the machine, se-

cured to a frame, A' , and constructed in any suitable or well-known manner.

B represents the separating or bolting screen, arranged in an inclined position within the case A, and composed of a suitable number of sections, $b b'$, arranged side by side. The several sections are clothed with bolting-cloth of the proper mesh, in accordance with the particular kind of work for which the machine is designed. Ordinarily the sections are clothed
60 with cloth of increasing coarseness from the head toward the tail of the machine, the section b being covered with the finest and the section b' with the coarsest cloth. The screen is preferably so inclined that the material will
65 flow over the same by gravity.

C represents the meal-chamber above the screen B, in which the elevating mechanism D is arranged, and which receives the material to be separated or bolted.
70

E represents the flour-chamber underneath the screen, which receives the fine material which has been bolted through the inclined screen, and which is provided with suitable conveyers, $e e'$, and slides e'' , for drawing off
75 the various grades of the bolted material, as may be desired. The elevating mechanism consists, preferably, of pulleys or drums $d d'$ and buckets $f f$, secured to one or more endless belts or chains, f' , running around the
80 pulleys $d d'$; but any other suitable elevator—for instance, a bucket-reel—may be employed, if preferred.

g represents the feed-opening through which the material to be separated or bolted is delivered into the meal-chamber C.
85

H H' H² represent air-chambers arranged above the several sections of the screen, separated by partitions $h h'$, which extend to or nearly to the surface of the screen.
90

$e^2 e^3$ are partitions formed in the flour-chamber E underneath the screen, and located underneath the partitions $h h'$ of the air-chamber, and dividing the flour-chamber into compartments corresponding with the air-chambers H H' H².
95

$e^4 e^5 e^6$ are air-openings, through which air is admitted to the compartments of the flour-chamber E.

I represents a suction-fan, the eye of which
100

is connected with the air-chambers $H H' H^2$ by spouts $i i' i^2$, each opening into one of the air-chambers, and provided with a slide or damper, e^3 , by which the force and volume of the air-currents drawn through the several air-chambers can be regulated. The increasing coarseness of the texture of the bolting-cloth with which the different sections of the screen are covered, in connection with the increasing coarseness and decreasing bulk of the material flowing over successive sections, tends to grade the strength of the air-currents which are drawn through successive screen-sections, so that light air-currents are drawn through the fine sections, and stronger or heavier currents through the coarser sections, in the absence of any other means for regulating the air-currents. The chambers $H H' H^2$ are arranged side by side between the lower side of the elevating mechanism and the upper side of the screen.

$k k'$ are flexible strips or curtains secured, respectively, to the upper and lower edges of the air-chambers, and resting on the screen or casing, to prevent, as far as possible, the admission of air to the air-chambers, except through the meshes of the screen. The ends of the screen-frame project through openings $m m'$, formed in the end walls of the case A. One end of the screen-frame rests against a spring, n , and the other end of the screen-frame is struck by a knocker, whereby the screen is jarred and the meshes are kept open.

o represents adjustable deflecting-boards pivoted to the upper side of the top plate, j' , of the air-chamber, and connected by a shifting-bar, o' , whereby the position of the deflecting-boards o can be regulated. These deflecting-boards can be adjusted so as to turn or deflect the material as it is discharged from the elevator toward or from the head of the machine, thereby accelerating or retarding the tendency of the material to work toward the tail end of the machine, which tendency is given to the material by a slight inclination or pitch of the machine from its head toward its tail end. By inclining the deflecting-boards more or less toward the head of the machine the progress of the material toward the tail end is more or less retarded. The deflecting-boards are preferably arranged more closely together as they approach the tail end of the machine, as represented in Fig. 4, thereby retarding the material more and more in the same measure as its quantity grows less by the removal of the fine material which is bolted out. If preferred, the machine may be arranged horizontally, and the movement of the material from the head to the tail of the machine may be effected solely by the deflecting-boards o .

$P P' P^2$ represent wipers or cleaners arranged in the several air-chambers $H H' H^2$, so as to bear upon the upper sides of the several screen-sections. The wipers $P P' P^2$ are attached to a frame, Q , which travels back and forth above the upper surface of the screen. The wipers P

$P' P^2$ are arranged in vertical planes, and extend from the upper to the lower edges of the screen-sections, their reciprocating movement taking place in planes at right angles to the inclination of the screen. The wiper-frame Q consists of horizontal bars q , which are guided in openings formed in the partitions $h h'$, and inclined connecting-bars q' , which are rigidly secured to the bars q . The wipers $P P' P^2$ consist each of a series of bars or stocks, p , which are connected at their ends by links p' , and provided on their under sides with wires p^2 , or strips of rubber, felt, or other flexible material, or brushes which bear upon the upper side of the screen. As each wiper consists of a series of members flexibly connected together, it is free to adapt itself to the surface of the cloth, if the latter should bag or sag between the frame or ribs of the screen. The frame Q is actuated by a bar, r , which is secured with its lower end to the frame Q , and projects through an elongated opening or slot, r' , formed in the top plate of the central air-chamber, H' . This slot is protected by strips of rubber or other elastic material, which substantially prevent the air from passing through said slot. The upper end of the bar r projects through a horizontal slot, r^2 , formed in the front wall of the casing A. The bar r is actuated by a horizontal endless belt, R , arranged at the front side of the machine, near the slot r^2 . The belt R runs over two pulleys, $s s'$, and is connected with the bar r by a cord or chain, s^2 , whereby the arm r and the frame Q , attached thereto, are drawn back and forth. The pulley s is secured to a short shaft which turns in a bracket, s^3 , and which carries at its outer end a bevel-wheel, s^4 . The latter is driven by a bevel-pinion, s^5 , which is secured to the inner end of a horizontal shaft, s^6 , its outer end being provided with a pulley, T , to which motion is communicated by an endless belt, t , from a pulley, t' , mounted on the upper shaft of the elevating mechanism. The pulley s' turns loosely on an arbor or stud which is secured to a bracket, t^2 . Both pulleys are unobstructed at their inner sides, so that the chain or cord s^2 can pass freely around the pulley with the belt. The lateral movement of the frame Q and of each wiper is limited to the length of one compartment or chamber, H . The requisite reduction of the movement imparted to the end of the chain s^2 by the endless belt to that required by the frame Q is readily effected by the slack of the chain s^2 . The reciprocating movement of the wipers is comparatively slow, so as not to interfere with the normal movement of the material across the sieve from the feed end toward the tail of the machine.

The middlings to be purified are fed into the meal-chamber C through the spout g , or in any other suitable manner. The middlings are elevated from the bottom of the casing and caused to flow repeatedly over the inclined screen. In passing over the fine screen-section b at the head of the machine the material

is subjected to a light air-current, adapted to the separation and removal of the light impurities. This light air-current is caused partly by the close texture of the bolting-cloth, the density of the mass of material flowing over the screen, and the adjustment of the air-current by the slide in the spout *i*. In flowing over the next coarser section, *b'*, the material encounters a heavier air-current, by reason of the coarser texture of the cloth, the decreased bulk of the material, and the adjustment of the slide in the trunk *i'*. A still stronger air-current operates upon the material passing over the next coarser section, *b''*, and for the same reasons. The purified middlings which pass through the screen are collected in the meal-chamber and discharged separated into different grades, or together, as may be desired. The light impurities are removed by the air-currents, and the bran and heavy residuary material are tailed off through an opening formed near the bottom of the casing at the tail end of the machine.

It is obvious that the air-currents may be directed through the screen by a blast fan or fans, instead of a suction-fan, if preferred.

I do not claim in this application anything claimed in my application No. 114,262, filed December 12, 1883.

I claim as my invention—

1. In a middlings-purifier, the combination, with an inclined screen composed of sections having different degrees of fineness arranged side by side, of an elevator, whereby the material escaping from the lower end of the screen is returned to its upper end, means whereby the material is caused to move laterally across the screen from the fine to the coarse sections, and an air-trunk and fan, whereby an air-current is directed upwardly through the screen, substantially as set forth.

2. In a middlings-purifier, the combination, with an inclined screen, of an air-trunk and fan, whereby an air-current is directed upwardly through the screen, an elevator, whereby the material escaping from the lower end of the screen is returned to its upper end, means whereby a lateral motion across the screen is imparted to the material, and a cleaner operating to keep the screen open, substantially as set forth.

3. In a middlings-purifier, the combination, with an inclined screen composed of sections of different degrees of fineness, arranged side by side, of an elevator, whereby the material escaping from the lower end of the screen is returned to its upper end, an air-trunk and fan, whereby air-currents are directed upwardly through the screen, and means whereby the force of the air-currents which pass through the different sections of the screen can be regulated, substantially as set forth.

4. In a middlings-purifier, the combination, with an inclined screen composed of sections of different degrees of fineness, arranged side by side, of an elevator, whereby the material escaping from the lower end of the screen is returned to its upper end, a fan, whereby air-currents are caused to pass upwardly through the screen, and a divided air-trunk having adjusting devices for regulating the force of the air-currents through the different sections of the screen, substantially as set forth.

Witness my hand this 19th day of November, 1883.

ORVILLE M. MORSE.

Witnesses:

JNO. G. MUNDY,
CHAS. F. GEYER.