

(No Model.)

2 Sheets—Sheet 1.

F. H. RICHARDS.

COTTON GIN.

No. 305,230.

Patented Sept. 16, 1884.

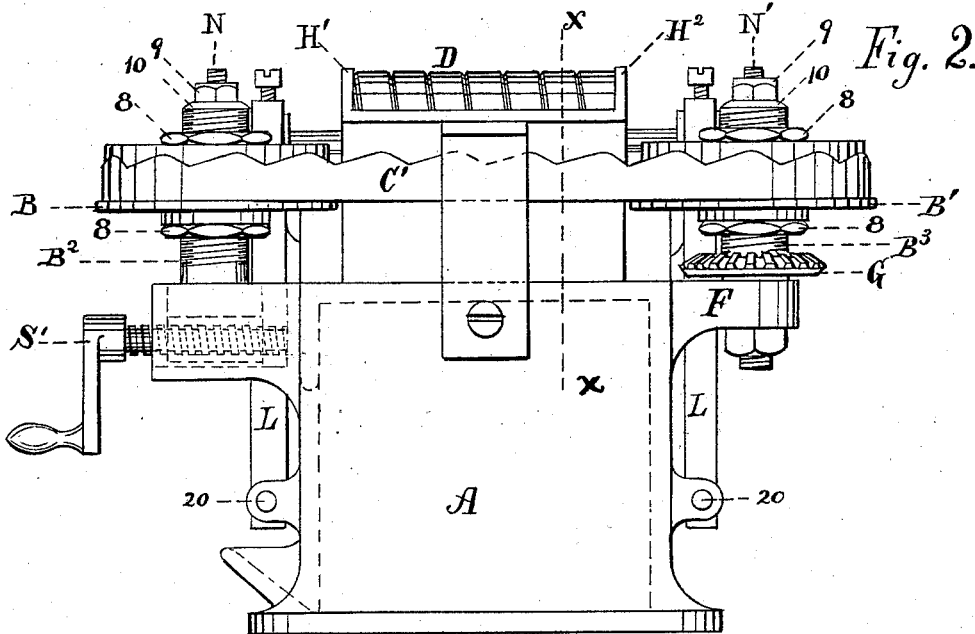
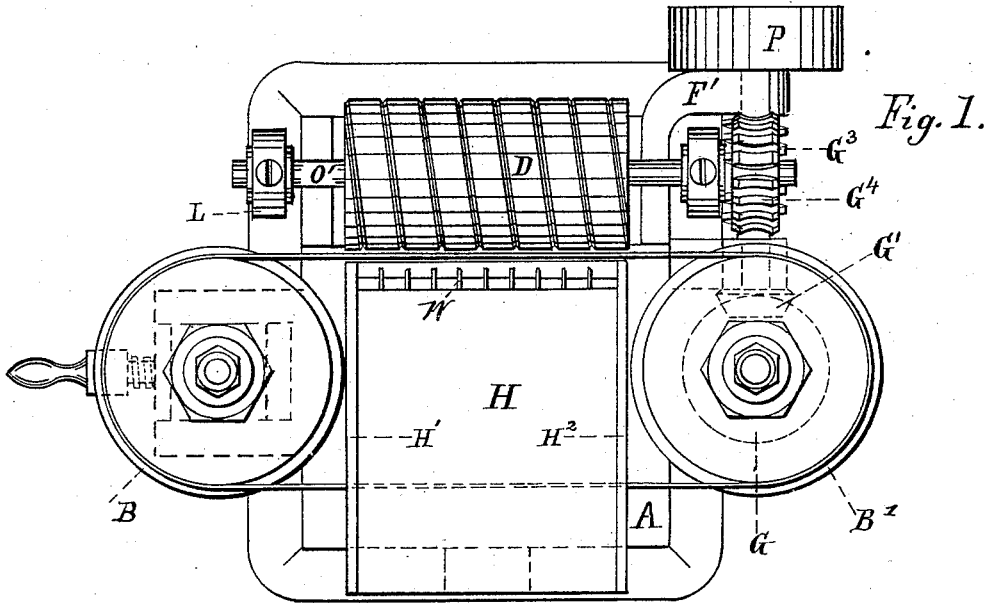

Witnesses;
H. W. Faulkner
C. O. Palmer.

Inventor;
Francis H. Richards.

(No Model.)

2 Sheets—Sheet 2.

F. H. RICHARDS.

COTTON GIN.

No. 305,230.

Patented Sept. 16, 1884.

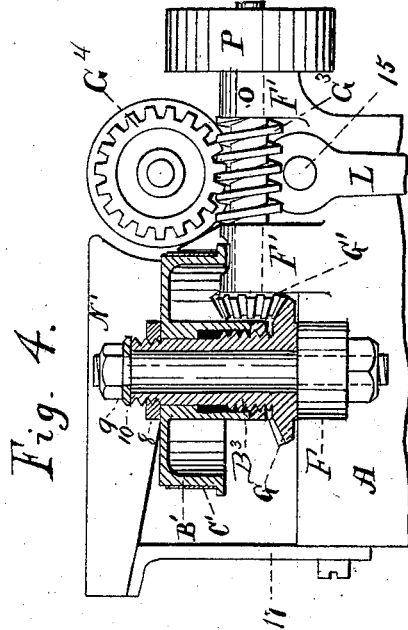

Fig. 4.

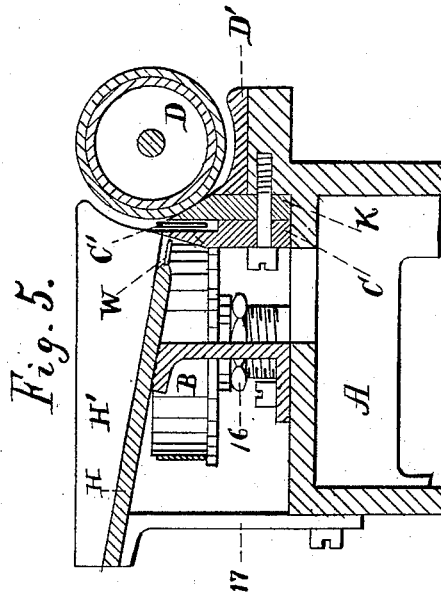

Fig. 5.

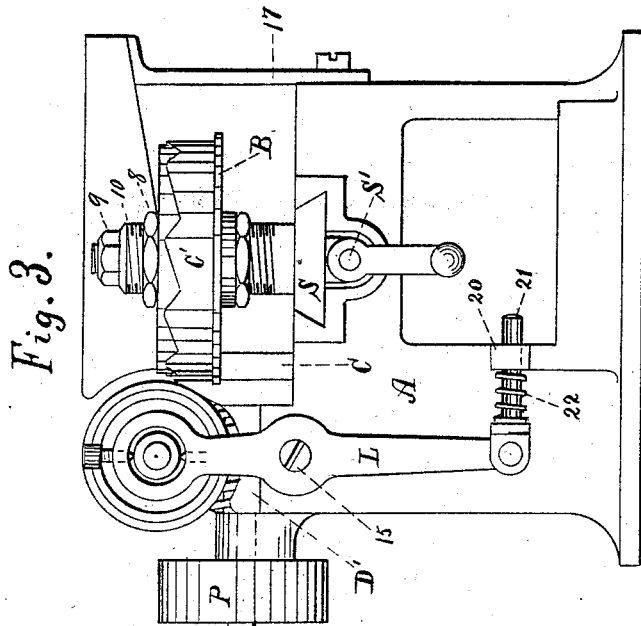

Fig. 3.

Witnesses;
H. N. Faulkner
C. O. Palmer.

Inventor
Francis H. Richards.

UNITED STATES PATENT OFFICE.

FRANCIS H. RICHARDS, OF SPRINGFIELD, MASSACHUSETTS, ASSIGNOR TO
THE PRATT & WHITNEY COMPANY, OF HARTFORD, CONNECTICUT.

COTTON-GIN.

SPECIFICATION forming part of Letters Patent No. 305,230, dated September 16, 1884.

Application filed December 31, 1883. (No model.)

To all whom it may concern:

Be it known that I, FRANCIS H. RICHARDS, a citizen of the United States, residing at Springfield, in the county of Hampden and State of Massachusetts, have invented certain new and useful Improvements in Cotton-Gins, of which the following is a specification, reference being had to the accompanying drawings.

My invention relates to that class of cotton-gins known as "roller-gins," and to that kind thereof having a seed-clearer of the form of an endless band, substantially as shown in Letters Patent of the United States No. 185,452, granted to E. Osgood, December 19, 1876, to which reference may be had; and it consists in certain combinations of mechanism hereinafter described and claimed.

Figure 1 is a plan view of a machine embodying my invention. Fig. 2 is a front elevation of the same. Fig. 3 is an end elevation of the left-hand end of Fig. 1. Fig. 4 is a partial end view of the right-hand end in Fig. 1; Fig. 5, a vertical transverse section in line *x x* of Fig. 2.

Similar letters refer to similar parts throughout the several views.

The frame of the machine, which I prefer shall be of a box form, substantially as shown, has secured thereto the usual doctor-knife, K, guard-plate C, and guide-plate D', two lugs, F', formed or secured thereon, in which are formed the bearings for driving-shaft O, a lug, F, in which is secured the stud N, lugs for rods 21, bearing-surfaces for feed-board supports, and a recess properly formed to receive the slide S. Two levers, L, are pivoted to the frame by means of screws 15, and are adapted to carry at their upper ends the friction-roll D, which has the usual covering of leather or similar material. The shaft of this roll carries at one end a worm-gear, G⁴, whereby it is rotated. A sufficient pressure of the roll D upon the doctor-knife may be secured by means of rods 21, springs 22, and lugs 20, or by a weighted lever. The slide S carries a stud, N, which carries the wheel B. Said slide is traversed by means of a screw, S', which passes through a tapped hole in said slide and acts against the frame, and is operated by a crank, as shown,

or otherwise, for the purpose of adjusting the tension of the endless clearer C'. The studs N and N' have fitted over them a thimble, B² and B³, respectively, secured by nuts and washers 9 10, and to these thimbles are fitted the band-wheels B B'.

Upon the band-wheels B and B' is placed the endless clearer C'. The upper edge of said clearer is undulated, as plainly shown in Figs. 2 and 3. Suitable nuts, 8, above and below the band-wheels, are provided for adjusting them to and securing them in any required position upon the thimbles. These band-wheels have flanges at their lower edges, to prevent the clearer C' from being forced downward by the pressure of the cotton upon its upper edge.

Upon thimble B³ is formed or secured a gear, G, which receives its motion from a pinion, G', on driving-shaft O, the latter being driven by pulley P. The driving-shaft also carries a worm-pinion, G³, gearing into the worm-wheel G⁴, which is fixed to the shaft of the friction-roll whereby the latter is driven. These gears are constructed of such proportions relative to each other, the size of friction-roll D and band-wheel B' being duly considered, that the velocity of the endless clearer shall be preferably about eight or ten times as great as the velocity of the surface of said friction-roll.

Upon the front of the doctor-knife is secured a suitable guard-plate, C, and in the space between these the endless clearer C' is adapted to run. Beneath the friction-roll a guide-plate, D', may be placed for the purpose of passing the mass of ginned cotton out of the machine in good shape.

A feed-board, H, having sides H' H², is supported in any convenient manner, as upon posts 16 and 17, and has the usual grating, W, for the escape of the ginned seeds, allowing them to fall into the seed-box, this being the chamber within the frame A, as shown, from which they may be removed at convenient intervals.

The operation of my improved roller cotton-gin is as follows: Power is applied to the machine by means of a band upon pulley P, which, by means of gearing described, causes the

rapid rotation of the band-wheel B', and thereby the endless clearer; and a slower rotary motion of the friction-roll D is imparted by means of the worm-gearing described. Seed-cotton is now applied to the feed-board and pushed by the operator against the friction-roll, which draws a portion of the lint of the same downward between the said roll and the doctor-knife. The motion of the clearer, by means of the elevations on its upper edge, the same being properly adjusted therefor, gives to the seeds of the cotton-lint so held a succession of rapid blows, severing the cotton fibers therefrom and allowing them to fall through the grating into the seed-box. When the seeds are thus separated, the lint from the same is carried under the roll D and issues from the machine at the back side. As the lint of one lot of seeds is removed therefrom the motion of the friction-roller brings other lint into its place, and thus the operation is continuous so long as the feed-board is properly supplied.

By means of the described construction of the band-wheels, their supporting-thimbles, and the studs N N', the draft or tension of the clearer tends to keep the bearing of the said thimbles upon said studs equal throughout

their whole length, thereby causing the clearer to run true, and not run upward and off from the wheels. By the arrangement of gearing shown and described, the entire driving mechanism is brought into a compact form and made to operate advantageously.

Having thus described my invention, I claim—

1. In a cotton-gin, in combination, a doctor-knife and a friction-roll, an endless seed-clearer, flanged band-wheels B and B', thimbles B² and B³, studs N and N', means for adjusting and securing said band-wheels upon said thimbles, and means for adjusting stud N relative to stud N', whereby said clearer may be tightened upon said wheels, substantially as described.

2. In a cotton-gin, in combination, a doctor-knife and a friction-roll, an endless seed-clearer, flanged band-wheels B and B', thimbles B² and B³, studs N and N', and means for adjusting and securing said band-wheels upon said thimbles, substantially as described.

FRANCIS H. RICHARDS.

Witnesses:

C. O. PALMER,

GEO. A. REYNOLDS.