

F. H. RICHARDS.  
GEAR CUTTING MACHINE.

No. 305,231.

Patented Sept. 16, 1884.

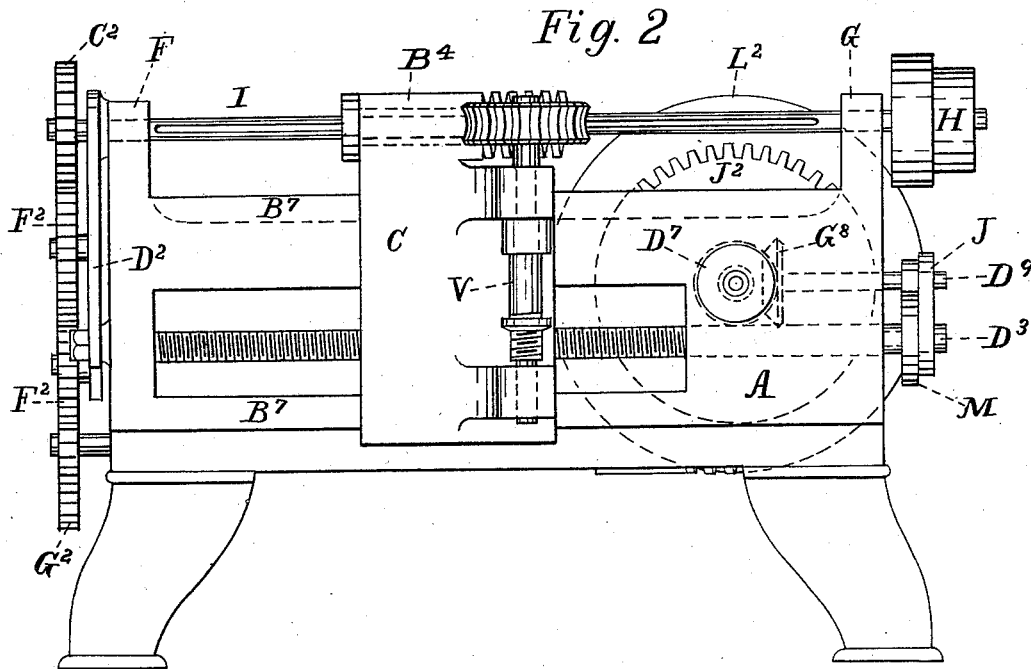
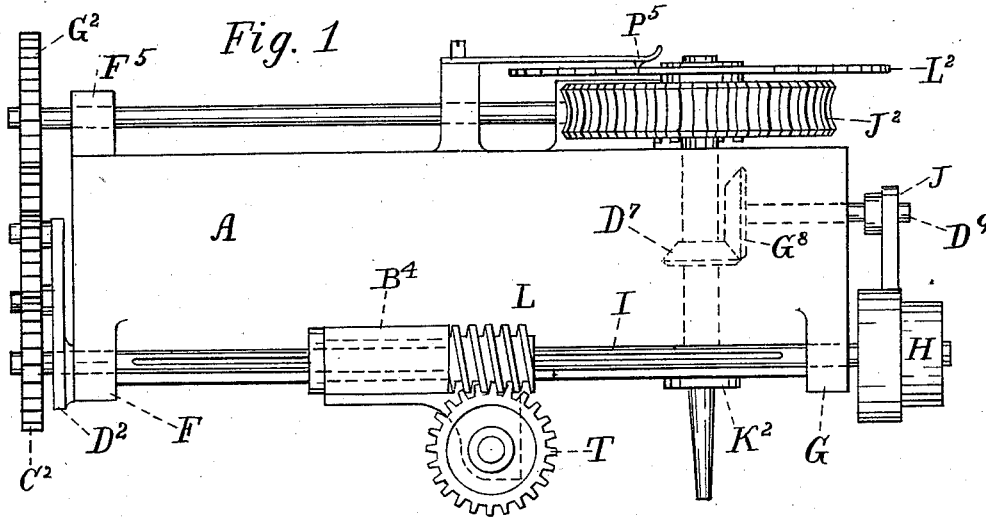

Witnesses;

*H. W. Faulkner*  
*Chas. Q. Palmer.*

Inventor;

*Francis H. Richards*

F. H. RICHARDS.  
GEAR CUTTING MACHINE.

No. 305,231.

Patented Sept. 16, 1884.

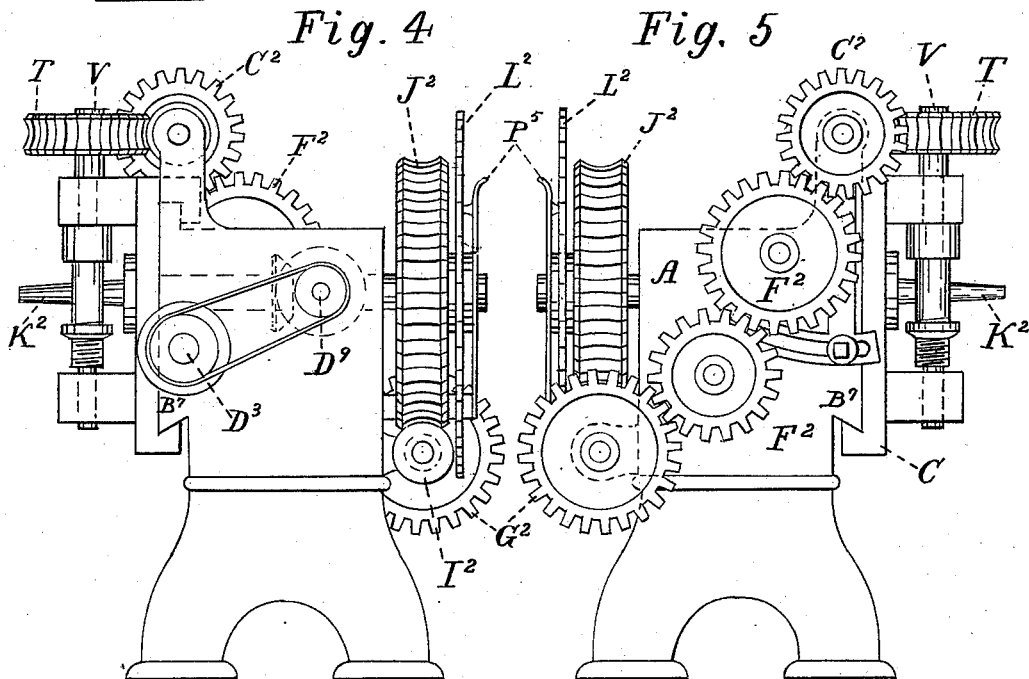
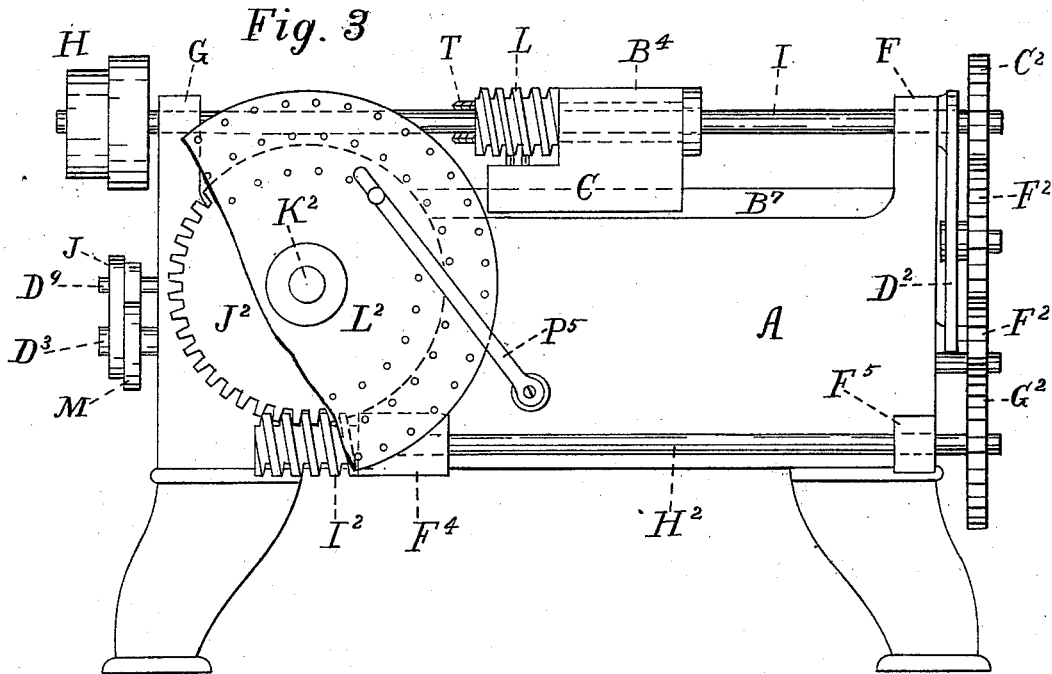

Witnesses;  
*H. W. Faulkner.*  
*Chas. O. Palmer.*

Inventor;  
*Francis H. Richards.*

# UNITED STATES PATENT OFFICE.

FRANCIS H. RICHARDS, OF SPRINGFIELD, MASSACHUSETTS, ASSIGNOR TO  
THE PRATT & WHITNEY COMPANY, OF HARTFORD, CONNECTICUT.

## GEAR-CUTTING MACHINE.

SPECIFICATION forming part of Letters Patent No. 305,231, dated September 16, 1884.

Application filed December 31, 1883. (No model.)

### *To all whom it may concern:*

Be it known that I, FRANCIS H. RICHARDS, a citizen of the United States, residing at Springfield, in the county of Hampden and State of Massachusetts, have invented certain new and useful Improvements in Gear-Cutting Machines, of which the following is a specification, reference being had to the accompanying drawings.

My invention relates to that class of gear-cutting machines adapted for cutting worm-wheels by means of a hob, in which the blank-arbor and cutter-arbor are revolved harmoniously by means of gearing intermediate to them.

The object of my invention is to provide a machine for that purpose, of simple and rigid construction, adapted to perform the cutting of worm-wheels at two operations—first, removing a portion of the metal required to be removed by means of a circular cutter; second, completing the form of the teeth of said wheel by means of a hob or helical cutter.

For the attainment of these objects my invention consists in a rigid frame-work, a blank-carrying mechanism having a master-wheel for revolving the blank continuously, and an index for spacing the same, a cutter-carrying mechanism adapted to slide on the frame toward and from the blank-arbor, an independent source of power or driving-shaft supported in fixed bearings on said frame-work, gearing from that source of power to the cutter-carrying and to the blank-carrying mechanisms and feed mechanism.

Referring to the drawings, Figure 1 is a plan view of a machine embodying my invention. Fig. 2 is a front elevation. Fig. 3 is a rear elevation. Fig. 4 is an elevation of the left-hand end of Fig. 3, and Fig. 5 is an elevation of the right-hand end of Fig. 3.

Similar reference-characters refer to similar parts throughout the several views.

The frame A of the machine, which I prefer to locate in a horizontal position and to make hollow, rests upon a foundation or suitable supports, and has a fixed bearing for a blank-arbor, K<sup>2</sup>, bearings G F for the driving-shaft I, and F<sup>4</sup> F<sup>5</sup> for shaft H<sup>2</sup>, ways B' for carriage C, and bearings for shaft D<sup>9</sup>, and traversing-screw D<sup>3</sup>. These bearings may all be

of any suitable style and construction, formed on or attached to the frame A. The blank-arbor K<sup>2</sup>, which is or may be of the usual description used in such machines, carries a master-wheel, as J<sup>2</sup>, whereby the blank operated upon is continuously revolved, and an index, as L<sup>2</sup>, whereby the said blank may be spaced. That arbor also carries a pinion, D<sup>1</sup>, meshing with a gear, as G<sup>3</sup>, on shaft D<sup>9</sup>, on which shaft is a pulley, J, from which a belt transmits motion to a pulley, M, on screw D<sup>3</sup>, for the purpose of traversing carriage C on its ways B'. An index-pin, P<sup>5</sup>, of the usual description, is provided to operate in conjunction with the index. The shaft H<sup>2</sup>, which is supported in the fixed bearings F<sup>4</sup> and F<sup>5</sup>, carries a pinion, I<sup>2</sup>, for operating master-wheel J<sup>2</sup>, and a removably-fixed gear, G<sup>2</sup>, whereby that shaft itself is driven. The driving-shaft I, which is supported in fixed bearings G F, carries a pulley, H, by which it is driven, a gear, C<sup>2</sup>, for driving-shaft H<sup>2</sup>, by means of suitable intermediate gears, as F<sup>2</sup> and G<sup>2</sup>, and a pinion, L, splined thereto for driving the gear T. The adjustably-fixed yoke D<sup>3</sup> serves to support the one or more intermediate gears F<sup>2</sup>. The carriage C is adapted to travel on the ways B', and has a nut (not shown) to receive the screw B<sup>3</sup>. A bearing, B<sup>4</sup>, of suitable construction to receive a tubular extension of pinion L, is fixed to or formed on carriage C, whereby that pinion is kept in a fixed position relative to said carriage and made to slide on splined shaft I as that carriage slides on its ways. The carriage C also has suitable bearings for a cutter-arbor, as V, which carries and is driven by the gear T, hereinbefore referred to. The pinion I<sup>2</sup> is preferably, but not necessarily, a worm-pinion, and it may be placed above instead of below master-wheel J<sup>2</sup>. The gearing L T may be bevel-gearing, if the parts operating in conjunction therewith are suitably constructed and arranged therefor. When the machine is not to be used for cutting worm-wheels by means of a hob, gearing between shaft I and arbor V may be dispensed with, and other forms of power-transmitting appliance substituted therefor. The index L<sup>2</sup> may have holes, or notches, which are equivalent thereto, in the periphery instead of, as here shown, in the face thereof.

The bearings on carriage C for arbor V need not be rigidly fixed to that carriage, but may be adjustably fixed or traversably secured thereon. In the two latter cases the gearing between shaft I and arbor V must, of course, be adapted to those arrangements.

The operation of cutting worm-wheels in this machine is substantially the same as that operation in other machines of the same class, and will be obvious from the drawings to those familiar with that class of machines, so that no particular description thereof will be necessary. A suitable blank is fixed on arbor K<sup>2</sup>, and a suitable circular cutter—by which description I refer to such cutters as usually used for cutting spur-wheels—is suitably fixed on arbor V. One of the gears C<sup>2</sup>, F<sup>2</sup>, or G<sup>2</sup> is removed or thrown out of gear, the belt on pulleys J M is removed therefrom, or, by means not shown, the pulley M is unclutched from screw D<sup>2</sup>, the index and index-pin properly set, and the machine started by a belt on pulley, H. By means of a lever or other device (not shown) on screw D<sup>2</sup>, the carriage C is now moved toward arbor K<sup>2</sup> until the cutter has made a proper cut in the blank, when it is withdrawn therefrom. This operation is repeated until the blank is completely spaced, when the circular cutter is removed from arbor V, and a hob substituted therefor. A train of gearing of suitable proportions is now placed in working position between shafts I and H<sup>2</sup>, the index-pin removed from the index, and the partially-formed teeth completed in the usual manner.

I do not claim, broadly, in a machine of this class the blank-arbor K<sup>2</sup>, cutter-arbor V, and gearing, in combination therewith intermediate thereto for the purpose of rotating them harmoniously for the purpose described, as I am aware such combinations have been used; but I am not aware that such have ever been used having that gearing substantially as herein described and shown.

I claim as my invention—

1. In a gear-cutting machine of the class described, a frame, as A, having a fixed bearing for the blank-arbor K<sup>2</sup>, ways, as B<sup>1</sup>, thereon for a carriage, C, bearings, as G F, for a shaft, I, that is parallel to said ways, and bearings, as F<sup>4</sup> F<sup>5</sup>, for a shaft, H<sup>2</sup>, in combination with arbor K<sup>2</sup>, shaft H<sup>2</sup>, gearing between said arbor K<sup>2</sup> and said shaft H<sup>2</sup>, shaft I, gearing between said shaft I and said shaft H<sup>2</sup>, a car-

riage, as C, adapted to slide on ways B<sup>1</sup>, and having bearings for a cutter-arbor, as V, a cutter-arbor, as V, on said carriage, and gearing between said shaft I and said cutter-arbor, substantially as and for the purpose described.

2. In a gear-cutting machine of the class described, a frame, as A, having a fixed bearing for the blank-arbor K<sup>2</sup>, ways, as B<sup>1</sup>, thereon for a carriage, C, bearings, as G F, for a shaft, I, that is parallel to said ways, and bearings, as F<sup>4</sup> and F<sup>5</sup>, for a shaft, H<sup>2</sup>, in combination with arbor K<sup>2</sup>, shaft H<sup>2</sup>, gearing between said arbor K<sup>2</sup> and said shaft H<sup>2</sup>, shaft I gearing between said shaft I and said shaft H<sup>2</sup>, a carriage, as C, adapted to slide on ways B<sup>1</sup>, and having bearings for a cutter-arbor, as V, a cutter-arbor, as V, on said carriage, and gearing between said shaft I and said cutter-arbor, substantially as and for the purpose described.

3. In a gear-cutting machine of the class described, a frame, as A, having a fixed bearing for the blank-arbor K<sup>2</sup>, ways, as B<sup>1</sup>, thereon for a carriage, C, bearings, as G F, for a shaft, I, that is parallel to said ways, and bearings, as F<sup>4</sup> and F<sup>5</sup>, for a shaft, H<sup>2</sup>, in combination with arbor K<sup>2</sup>, shaft H<sup>2</sup>, worm-gearing between said arbor K<sup>2</sup> and said shaft H<sup>2</sup>, shaft I, gearing between said shaft I and said shaft H<sup>2</sup>, a carriage, as C, adapted to slide on ways B<sup>1</sup>, and having bearings for a cutter-arbor, as V, a cutter-arbor, as V, on said carriage, and gearing between said shaft I and said cutter-arbor, substantially as and for the purpose described.

4. In a gear-cutting machine of the class described, a frame, as A, having a fixed bearing for the blank-arbor K<sup>2</sup>, ways, as B<sup>1</sup>, thereon for a carriage, as C, bearings, as G F, for a shaft I, that is parallel to said ways and bearings, as F<sup>4</sup> and F<sup>5</sup>, for a shaft, H<sup>2</sup>, in combination with arbor K<sup>2</sup>, shaft H<sup>2</sup>, gearing between said arbor K<sup>2</sup>, and said shaft H<sup>2</sup>, shaft I, gearing between said shaft I and said shaft H<sup>2</sup>, a carriage, as C, adapted to slide on ways B<sup>1</sup>, and having bearings for a cutter-arbor, as V, a cutter-arbor, as V, on said carriage, and worm-gearing between said shaft I and said cutter-arbor, substantially as and for the purpose described.

FRANCIS H. RICHARDS.

Witnesses:

CHAS. O. PALMER,  
F. A. PRATT.