

(No Model.)

H. HOLLAND.

DEVICE FOR HITCHING HORSES.

No. 343,993.

Patented June 22, 1886.

Fig.1.

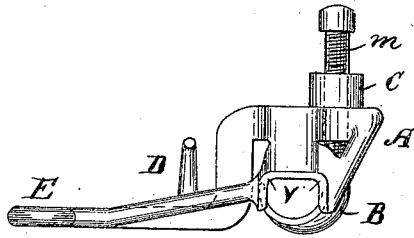

Fig.2.

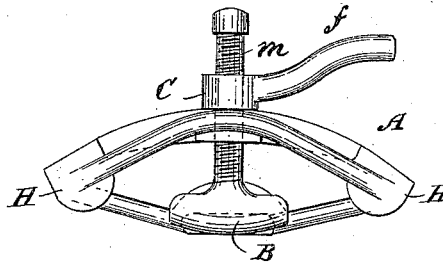

Fig.3.

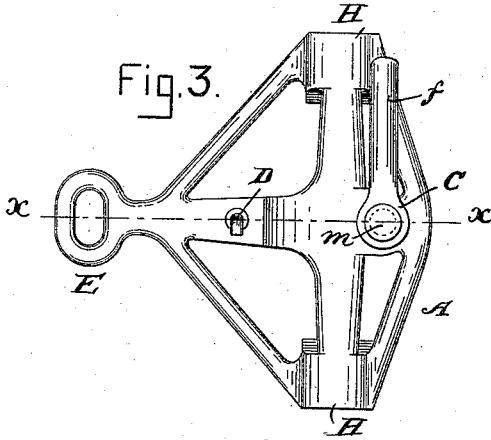

Fig.4.

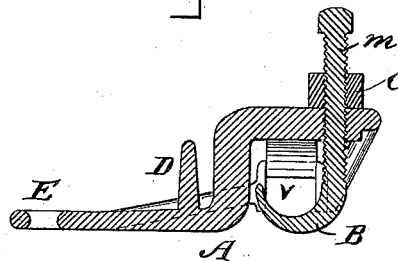

Fig.5.

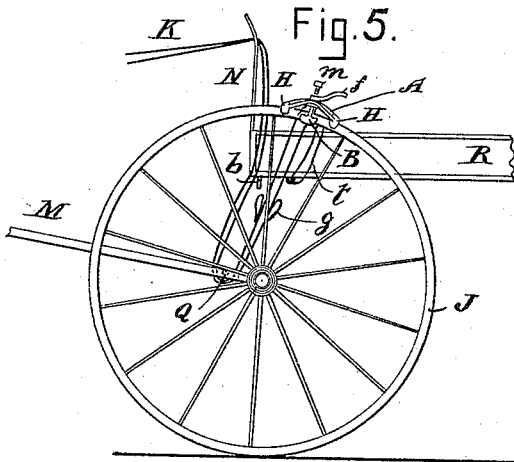
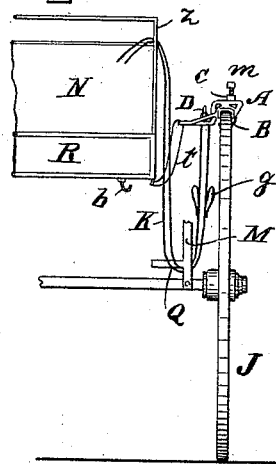

Fig.6.



Witnesses.

W. Blanta.
L. J. White.

Inventor.

Harold Holland,
Per C. Shaw,
Attorney.

UNITED STATES PATENT OFFICE.

HAROLD HOLLAND, OF LYNN, MASSACHUSETTS.

DEVICE FOR HITCHING HORSES.

SPECIFICATION forming part of Letters Patent No. 343,993, dated June 22, 1886.

Application filed January 25, 1886. Serial No. 189,606. (No model.)

To all whom it may concern:

Be it known that I, HAROLD HOLLAND, of Lynn, in the county of Essex, State of Massachusetts, have invented a certain new and useful Improvement in Devices for Hitching Horses, of which the following is a description, sufficiently full, clear, and exact to enable any person skilled in the art or science to which said invention appertains to make and use the same, reference being had to the accompanying drawings, forming part of this specification, in which—

Figure 1 is an end elevation of the clamp detached from the wheel; Fig. 2, a side elevation of the same; Fig. 3, a top plan view; Fig. 4, a vertical section taken on line *x x* in Fig. 3; Fig. 5, a side elevation showing the clamp attached to the wheel of a carriage, and Fig. 6 a front elevation of the same.

Like letters of reference indicate corresponding parts in the different figures of the drawings.

My invention relates to that class of devices for hitching horses in which the forward movements of the carriage to which the horse is harnessed operate to check or stop the horse and prevent him from running away when left unattended; and it consists in a novel construction, arrangement, and combination of parts, as hereinafter more fully set forth and claimed, the object being to produce a simpler, cheaper, and more effective device of this character than is now in ordinary use.

The nature and operation of the improvement will be readily understood by all conversant with such matters from the following explanation.

In the drawings, A represents the body of the clamp, and B the hook. The body of the clamp is provided with an upwardly-projecting stud or hook, D, for the reins, and a loop, E, for the attaching-strap by which the clamp is secured to the carriage. The shank *m* of the hook B is arranged vertically, and passes loosely through a hole in the body A, being screw-threaded exteriorly, and provided above said body with a nut, C, having a handle, *f*. The ends H of the body A are cut out or have notches *v* formed on their undersides, to adapt them to receive the rim of the wheel J of the carriage.

In the use of my improvement the body A

of the clamp is placed on the top of the wheel J, the rim of the wheel being inserted in the notches *v*, as shown in Figs. 5 and 6, after which the clamp is secured to the wheel by the hook B and nut C, said hook being adjusted in such a manner as to rise under and engage the felly of the wheel when the nut is fully turned down. The driving-reins K, which are of course connected with the bit of the horse, (not shown,) are then passed around or partially around some fixed portion of the carriage, preferably the cross-bar of the shafts, near the forward end of its body R, and hooked onto the stud D of the clamp.

In Figs. 5 and 6 the reins are represented as passing over the fender or dash-board N of the carriage, being kept in position by the iron *z*, thence under the cross-bar Q of the shafts M, and thence to the hook or stud D; but, instead of carrying the reins over the board N, they may be carried under the cross-bar Q only, if preferred; or they may be carried over the fender, and not under the cross-bar, if desired. The body, shafts, axle, or rocker of the carriage may also be specially provided with a stud, clip, or other suitable device around or partially around which the reins may be carried on their way to the clamp, instead of being passed around the cross-bar. The clamp being firmly secured to the rim or felly of the wheel by the hook B and nut C, and the reins passed around or partially around some fixed portion of the carriage and attached to the stud D, as described, when the horse starts and the wheel J is turned it will wind up the driving-reins K, and thereby produce a strain on the bit and stop the horse in a manner which will be readily obvious without a more explicit description.

An anti-friction roller or wheel may be employed where the reins pass the cross-bar Q or other fixed portion of the carriage, if desired. A strap or chain, *t*, is passed through the loop or eye E of the clamp, said strap being connected to the body of the carriage, as seen in Fig. 6. There is also a hook, *b*, provided beneath the body of the carriage, on which the clamp is suspended when not in use. The reins K are provided with loops *g*, and, when too long, the loops are passed over the stud D of the clamp, instead of the end of the reins. The loops are made adjustable on the reins, to

enable them to be placed in the right position for this purpose.

The hook *b* may be attached to the shaft M or to the cross-bar Q, and the strap *t* may be
5 attached to the shafts, instead of the body of the carriage, if desired.

Having thus explained my invention, what I claim is—

1. In a hitching device of the character described, a clamp having the body A, provided
10 with the notches *v*, hook B, nut C, and stud D, substantially as set forth.

2. In a hitching device of the character described, a clamp having the body A, provided
with the notches *v*, hook B, nut C, and stud D, 15
in combination with the wheel J, reins K, and cross-bar Q, or a fixed portion of the carriage, around or partially around which said reins pass on their way to the clamp, substantially as described.

HAROLD HOLLAND.

Witnesses:

C. A. SHAW,
L. J. WHITE.