

J. E. McINTOSH.

ADJUSTABLE VALVE SEAT.

No. 344,190.

Patented June 22, 1886.

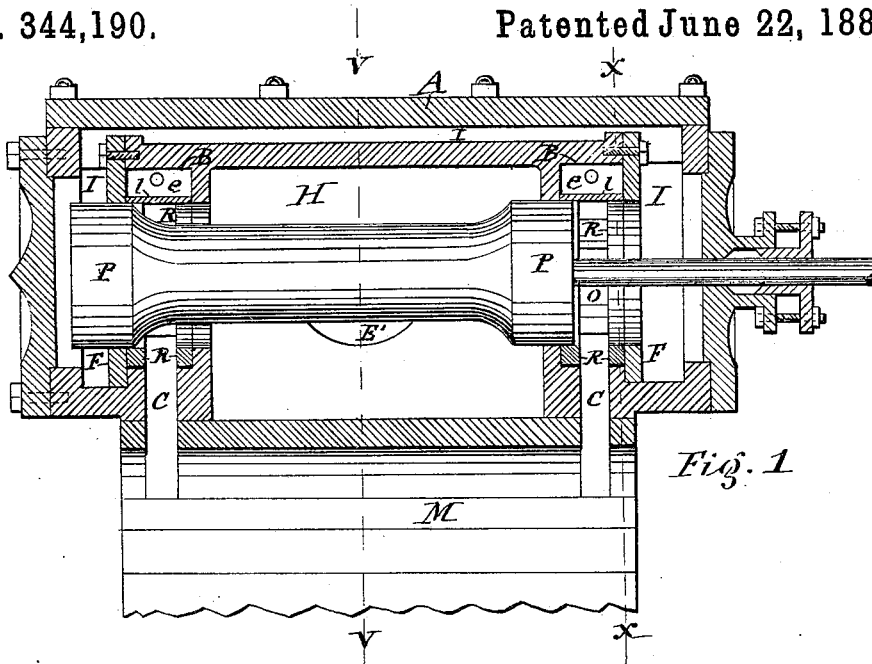

Fig. 1

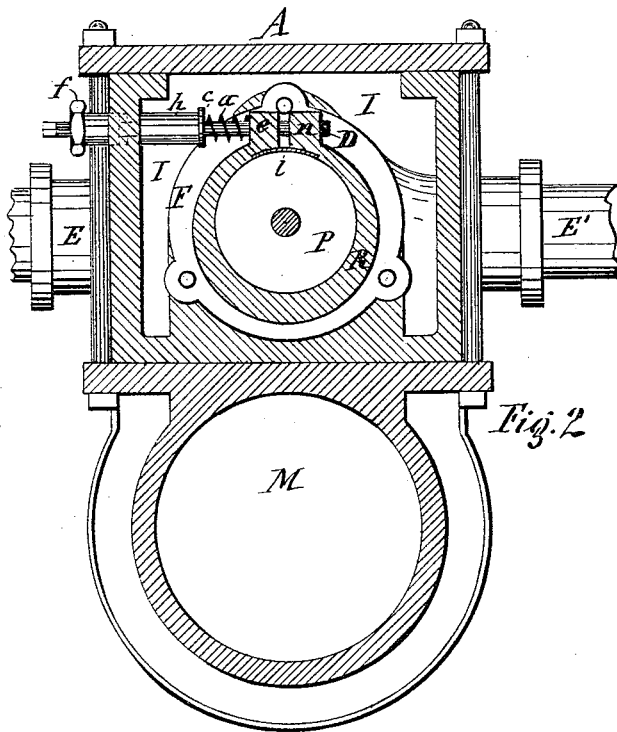

Fig. 2

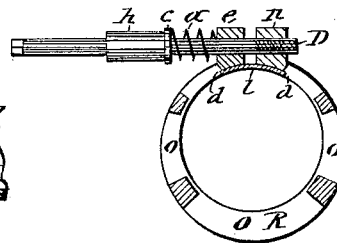

Fig. 4

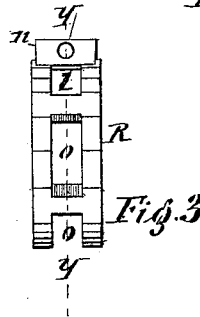

Fig. 3

INVENTOR:

*John E. McIntosh*  
 per *Wm. Lassit*  
*Atty*

WITNESSES:

*A. F. Mahy*  
*C. Bendison*

J. E. McINTOSH.  
ADJUSTABLE VALVE SEAT.

No. 344,190.

Patented June 22, 1886.

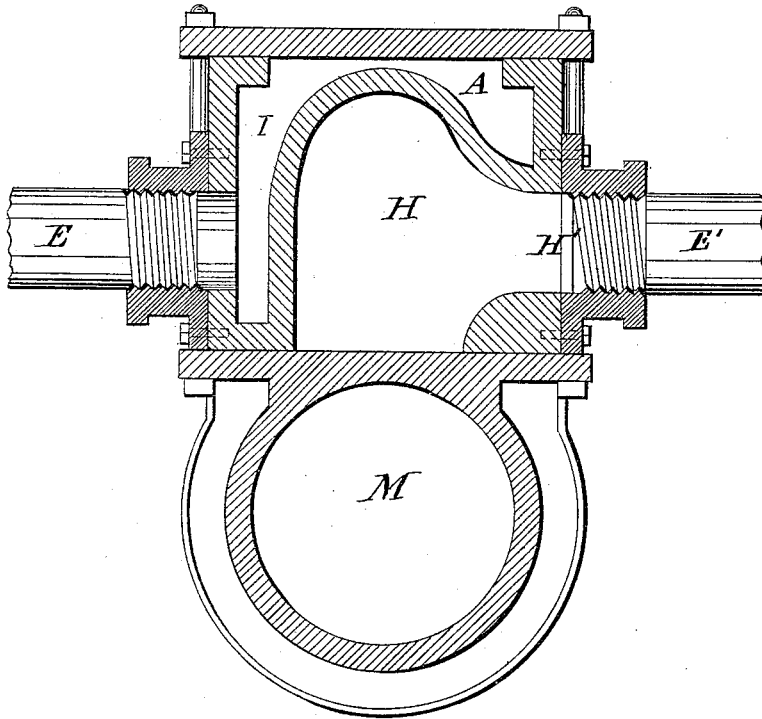

Fig. 5

WITNESSES:

W. F. Walz,  
W. Blandison.

INVENTOR:

John E. McIntosh  
per Knell, Lusk & Co.  
his Atty.

# UNITED STATES PATENT OFFICE.

JOHN E. McINTOSH, OF CAYUGA, NEW YORK.

## ADJUSTABLE VALVE-SEAT.

SPECIFICATION forming part of Letters Patent No. 344,190, dated June 22, 1886.

Application filed April 30, 1886. Serial No. 200,610. (No model.)

*To all whom it may concern:*

Be it known that I, JOHN E. McINTOSH, of Cayuga, in the county of Cayuga, in the State of New York, have invented new and useful  
5 Improvements in Adjustable Valve-Seats for Steam-Cylinders, of which the following, taken in connection with the accompanying drawings, is a full, clear, and exact description.

10 This invention relates to steam-chests and valve-seats especially designed for piston-valves.

The object of the invention is to provide simple, convenient, and efficient means for  
15 compensating for the wear of the bearings between the piston-valve and its seat in the steam-chest, so as to maintain said bearings properly fitted and steam-tight; and to that end the invention consists in the improved  
20 construction and combination of parts as hereinafter fully described, and specifically set forth in the claims.

In the annexed drawings, Figure 1 is a vertical longitudinal section of a steam-chest embodying my improvements. Fig. 2 is a vertical transverse section on line *x x* Fig. 1. Fig. 3 is a detached edge view of the adjustable valve-seat. Fig. 4 is a section taken on line  
25 *y y*, Fig. 3; and Fig. 5 is a transverse section on line *v v*, Fig. 1.

30 Similar letters of reference indicate corresponding parts.

A represents the steam-chest, the interior of which I form with an exhaust-chamber, H,  
35 extending part way the length and width of the steam-chest, so as to form spaces I I for live steam at the sides, ends, and top of the aforesaid exhaust-chamber.

E denotes the steam-pipe, which conducts  
40 the live steam to the steam-spaces I I of the steam-chest, and E' is the exhaust-pipe, which communicates with a duct, H', extended from the exhaust-chamber H through the side of the steam-chest. The exhaust-chamber H  
45 is formed at each end with an annular recess, B, and from said recess to the end of the interior of the steam-cylinder M is extended the steam-port C.

In the recess B is seated my improved adjustable valve-seat R, consisting, essentially,  
50 of a contractible ring which encompasses the

piston-valve P. Said ring I form of metal and sever it transversely with sufficient space between the adjacent ends of the ring to render it contractible circumferentially. One  
55 end of the ring is formed with a smooth eye, *e*, and the other end thereof is formed with a screw-threaded eye or nut, *n*. A screw, D, passes loosely through the eye *e* and works in the nut *n*, and has back of the eye *e* a smooth  
60 stem extending through the side of the steam-chest so as to be convenient of access for manipulation at the exterior of the steam-chest.

A stuffing-box, *f*, applied to the exterior of the steam-chest and embracing the aforesaid  
65 screw-stem, serves to prevent leakage of steam thereat.

On the stem of the screw D, between the eye *e* and adjacent wall of the steam-chest, is a rigid collar, *c*, and between this collar and the  
70 aforesaid wall, and abutting against the same, is a sleeve, *h*, on the aforesaid screw-stem, said sleeve serving to confine the screw-stem longitudinally.

Between the collar *c* and eye *e* is interposed  
75 a spring, *a*, which presses the eye *e* toward the nut *n*, and by turning the screw D in the right direction the aforesaid nut is drawn toward the eye, and thus the ring R can be contracted circumferentially to take up the wear  
80 between it and the valve P.

The ring R is provided with radial ports O, O, which communicate with the steam-port C, and it is secured in the recess B by an annular  
85 plate, F, detachably connected to the end of the extension of the exhaust-chamber, said plate lapping onto the ring R, and thus confining the same in the recess B.

In operating the piston-valve P it is reciprocated rectilinearly, and in its movement  
90 toward one end of the steam-chest it closes the communication between the steam-space I and ports O of the ring R at that end of the steam-chest and opens the communication from the steam-cylinder through the port C,  
95 ports O of the ring R, and thence through the exhaust-chamber H to the exhaust-pipe E', while at the opposite end of the steam-chest the valve P has moved into a position to permit the steam to pass from the steam-  
100 space I through the central opening of the plate F, thence through the ports O of the

ring R, and thence through the port C into the steam-cylinder M.

In order to prevent the steam from leaking through the joint made in the ring R by severing the same between the eye *e* and nut *n*, I provide the inner circumferential faces of the end portions of said ring with countersinks *d* *d*, and place therein a liner, *l*, which spans the aforesaid joint, as illustrated in Fig. 2 of the drawings.

Having described my invention, what I claim as new, and desire to secure by Letters Patent, is—

1. The combination, with a steam-chest and piston-valve, of an adjustable valve-seat consisting of a contractible ring encompassing the valve, and an adjustable tightener for contracting said ring to compensate for the wear of the bearings between the ring and valve, as set forth.

2. The combination, with a steam-chest and piston-valve, of a contractible ring encompassing the valve, and an adjusting screw and spring for compressing said ring circumferentially, substantially as and for the purpose set forth.

3. The combination, with a steam-chest and piston-valve, of the severed contractible ring R, encompassing the valve and secured in the steam-chest, and provided with the eye *e* and nut *n*, the screw D, confined longitudinally in the steam-chest, and passing through the eye *e* and working in the aforesaid nut, and the spring *a*, arranged to press the eye *e* toward the nut, substantially as described and shown.

4. The combination, with the steam-chest and piston-valve, of the contractible ring R,

secured in the steam-chest and provided with the eye *e* and nut *n*, the screw D, passing through said eye and working in the nut and extended through the side of the steam-chest, the collar *c*, rigidly attached to said screw, the sleeve *h*, interposed between said collar and side of the steam-chest, and the spring *a*, interposed between the collar and eye *e*, substantially as described and shown.

5. In combination with the steam-chest and piston-valve, the contractible ring R, secured in the steam-chest, and provided with the ports O O, substantially as described and shown.

6. The piston P, in combination with the steam-chest A, formed with the exhaust-chamber H, steam-spaces I I, recesses B B, and ports C C in said recesses, the rings R R, seated in the recesses and provided with ports O O, and the plates F F, confining the said rings in the recesses, substantially as described and shown.

7. In combination with the steam-chest and piston-valve, the contractible ring R, severed transversely, and provided with the countersinks *d*, and the liner *l*, seated in said countersinks, substantially as described and shown.

In testimony whereof I have hereunto signed my name and affixed my seal, in the presence of two attesting witnesses, at Syracuse, in the county of Onondaga, in the State of New York, this 10th day of April, 1886.

JOHN E. McINTOSH. [L. s.]

Witnesses:

FREDERICK H. GIBBS,  
E. C. CANNON.