

(No Model.)

C. B. ISBESTER.

DEVICE FOR FORMING BEADS IN SAND MOLDS.

No. 344,657.

Patented June 29, 1886.

Fig. 1.

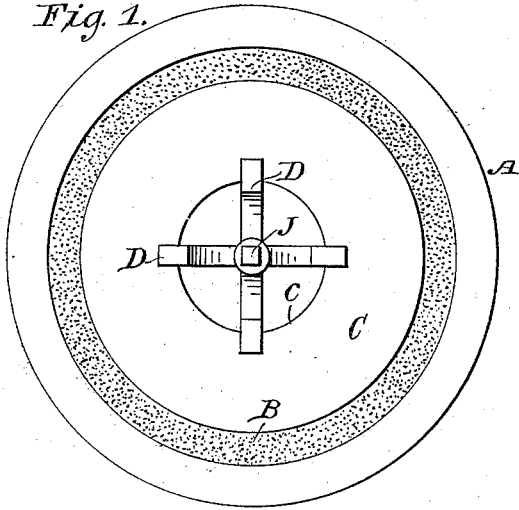

Fig. 3.

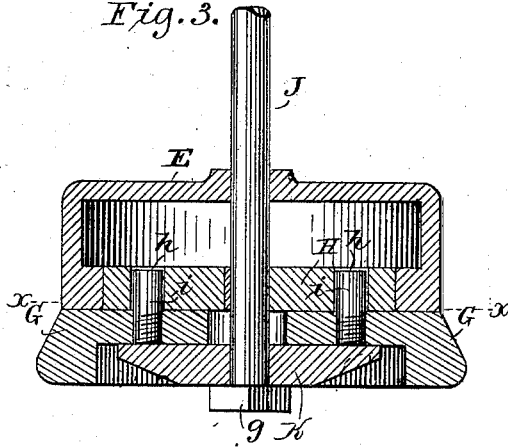

Fig. 4.

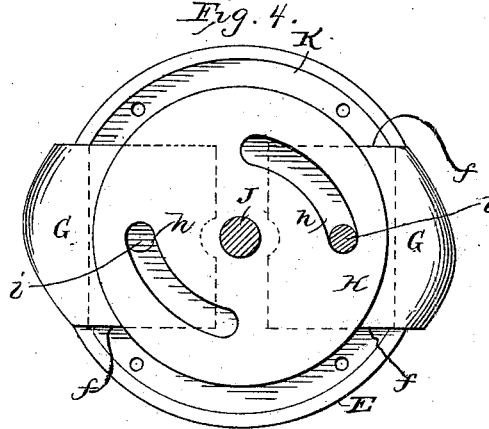

Fig. 2.

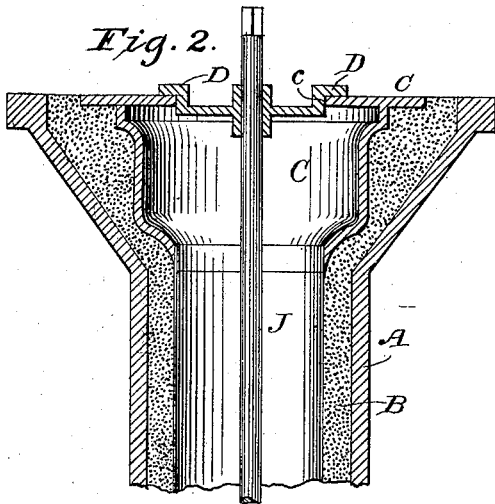
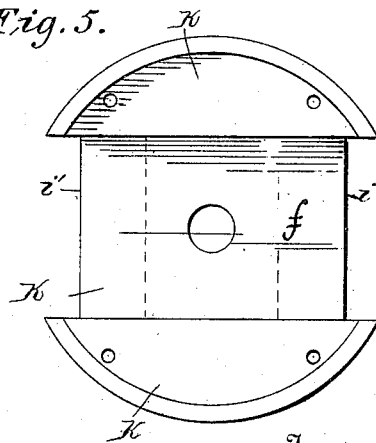

Fig. 5.



Witnesses
Jos. S. Latham
Edna Sheehy

Inventor
C. B. Isbester
 By his Attorney *Frank Sheehy*

UNITED STATES PATENT OFFICE.

CALEB B. ISBESTER, OF CHATTANOOGA, TENNESSEE.

DEVICE FOR FORMING BEADS IN SAND-MOLDS.

SPECIFICATION forming part of Letters Patent No. 344,657, dated June 29, 1886.

Application filed March 30, 1886. Serial No. 197,155. (No model.)

To all whom it may concern:

Be it known that I, CALEB B. ISBESTER, a citizen of the United States, residing at Chattanooga, in the county of Hamilton and State of Tennessee, have invented certain new and useful Improvements in Devices for Forming Female Beads in Sand-Molds; and I do declare the following to be a full, clear, and exact description of the invention, such as will enable others skilled in the art to which it appertains to make and use the same, reference being had to the accompanying drawings, and to the letters and figures of reference marked thereon, which form a part of this specification.

Figure 1 is a top view of a flask rammed up, with bell-mouth pattern for its head, and the bead-forming device and centering spider in position for operation. Fig. 2 is a vertical central section through Fig. 1 in the plane indicated by dotted line $x x$ thereon, part of the figure being broken away. Fig. 3 is an enlarged diametrical section through the bead-forming device and lower part of its shaft. Fig. 4 is a section, on line $x x$ of Fig. 3, of the bead-forming device without its casing. Fig. 5 is a top view of the grooved bottom of the said device.

My invention relates to improvements in devices for forming female beads in the ends of sand-molds adapted for casting pipes having male beads on their ends, which improvements will be fully understood from the following description when taken in connection with the annexed drawings.

Referring to the drawings by letters, A designates a cast-metal flask, which is preferably made of two longitudinal parts hinged together on one side, and provided with suitable fastenings on the opposite side in the usual well-known manner. This flask is formed of a barrel having a flanged flaring head or bell-mouth on one end and a flange, a , on the other end, by which latter and bolts or other fastenings the flanged chill-plate A' is secured to the bottom of the flask. This chill-plate is constructed with a central conical frustum, b , the vertical axis of which should coincide with the vertical axis of the flask and its flaring head, as shown in Fig. 1, which frustum forms a centering device for the pattern, and also for the core, which are used in the well-known manner, and not shown in the drawings.

B designates the sand-mold, which is first rammed in the flask, between it and the pattern; and C designates the bell-mouth pattern constructed, as shown in Figs. 1 and 2, with a hole, c , centrally through its ring or top plate, in which is adjusted a removable centering-spider, D, having shouldered arms radiating from a central boss. After the sand has been properly rammed in the flask, the chill-plate A' being at the time rigidly secured to the flanged bottom of the flask and the pattern removed, I employ the following device for producing the annular female bead d in the lower end of the sand-mold B, which bead is designed to form a male bead on the smaller end of the finished pipe.

E designates a cylindrical casing of any desired length, and of a diameter corresponding exactly to the internal diameter of the sand-mold B. The casing should be of such length or height that it will serve as a guide and prevent forcing of the sand. To the open bottom of this casing I bolt a circular plate, K, diametrically grooved at f , in which groove are two radially-sliding blocks, G G, having their outer ends beveled and rounded to make the exact impression desired in the sand-mold B.

On top of the plate K and sliding blocks G is a disk, H, which is keyed on a vertical shaft, J, that passes freely through the top of the casing E, freely through the bottom plate, K, and has a nut, g , tapped on its lower end. This bottom plate, K, is a support for the slides G, to hold them in place. The disk H is provided with eccentric slots $h h$, through which pins $i i$ pass, that are fixed into the sliding blocks G G.

It will be observed by reference to Figs. 3 and 5 that the bottom plate, K, is cut away at $i' i'$, the termini of its groove f , for the purpose of allowing the extreme outer ends of the sliding blocks G G to be retracted flush with the periphery of the casing E, and also to prevent accumulation of sand. It will also be observed that these blocks can be protruded beyond the periphery of said casing, or retracted, as above stated, by simply turning the shaft J, a hand-crank being applied on the upper end of this shaft for the purpose.

When the device has been lowered into the sand-mold in the flask, and rested upon the chill-plate A', the spider D is adjusted in its

place upon the core-print for exactly centering the said shaft in the flask. The molder then turns the shaft in the proper direction, which operation first protrudes the ends of the sliding blocks beyond the periphery of the casing E. The blocks and casing are then rotated together, and the annular female bead formed in the sand. The shaft J is then turned in an opposite direction to that above named, which will cause the sliding blocks to be retracted, and allow the device to be withdrawn from the mold, carrying with it the spider or upper shaft bearing, D. The core print or pattern for the head is now withdrawn, the core introduced, and the metal which forms the pipe poured.

Among the advantages of my bead forming device are that the impression for the bead, when the pipe is cast head up, is easily and quickly made, and after its formation does not require the removal of the flask to another bottom piece or chill-plate before pouring the metal, the pipe being cast directly upon the plate upon which the sand is rammed, and that it insures the core being truly central in the mold for the pipe; hence the axis of the core will exactly coincide with that of the mold. I do not limit myself to two reciprocating

blocks, G G, as a greater number may be used, especially for pipes of very large diameter.

Having described my invention, I claim—

1. A device for the purpose described, consisting of a grooved bottom plate, K, reciprocating female-bead formers applied in the groove of this plate, an eccentrically-slotted disk keyed on a shaft, J, pins fixed to said formers and entering the eccentric slots in said disk, and a guiding-casing, substantially as described.

2. The combination, in a bead-molding device, of the grooved bottom plate, K, having recesses *f f* at the termini of the groove, the bead-formers guided by and adapted to slide radially in the groove in said plate, and provided with pins *i*, the disk H, slotted eccentrically and receiving in these slots said pins, the shaft J, keyed to the disk, and provided with a nut, *g*, and the cylindrical cap or casing E, all constructed and adapted to operate substantially as and for the purposes described.

In testimony whereof I affix my signature in presence of two witnesses.

CALEB B. ISBESTER.

Witnesses:

HARRY W. DURAND,
J. B. ALLIN.