

(No Model.)

J. D. FISKE.  
VALVE FOR STEAM ENGINES.

No. 383,287.

Patented May 22, 1888.

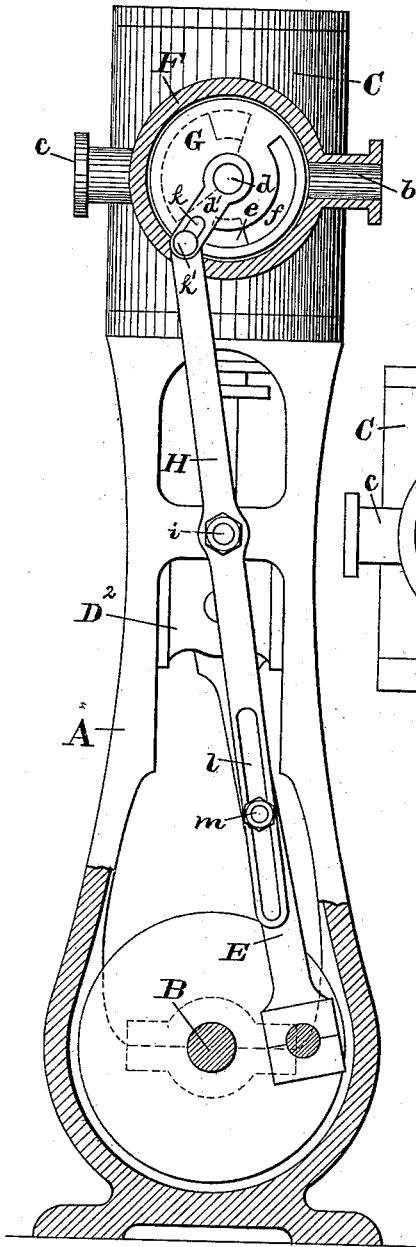

Fig. 1.

WITNESSES:

*R. L. Clemmitt*  
*John E. Morris*

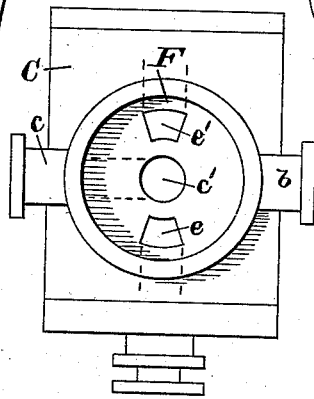

Fig. 4.

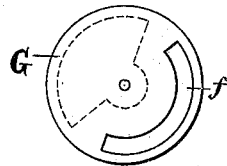

Fig. 5.

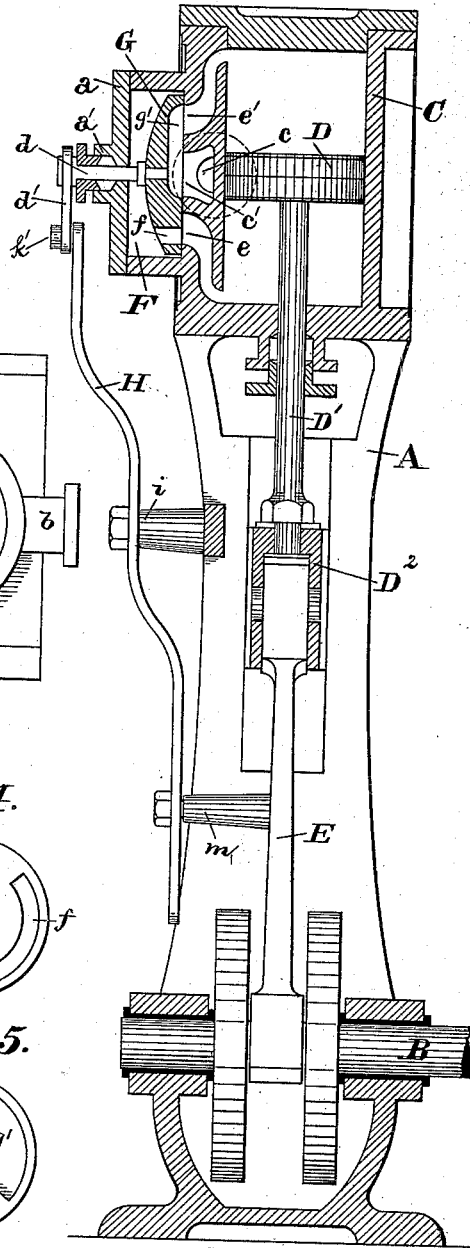
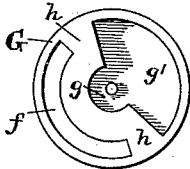

Fig. 2.

INVENTOR:

*J. D. Fiske*

BY *Chas B. Mann*

ATTORNEY.

# UNITED STATES PATENT OFFICE.

JOHN D. FISKE, OF BALTIMORE, MARYLAND.

## VALVE FOR STEAM-ENGINES.

SPECIFICATION forming part of Letters Patent No. 383,287, dated May 22, 1888.

Application filed December 19, 1887. Serial No. 258,414. (No model.)

*To all whom it may concern:*

Be it known that I, JOHN D. FISKE, a citizen of the United States, residing at Baltimore, in the State of Maryland, have invented certain new and useful Improvements in Valves for Steam-Engines, of which the following is a specification.

My invention relates to a cut-off valve for steam-engines, and is illustrated in the accompanying drawings, in which—

Figure 1 is an elevation of an engine, parts of which are in section, with the improved valve, which is here shown to oscillate. Fig. 2 is a sectional elevation of the engine and valve on the central vertical line 2 of Fig. 1. Fig. 3 is a side view of the cylinder and steam-chest with the cover thereof and valve removed. Fig. 4 shows the outer side of the valve. Fig. 5 shows the inner or exhaust-port face of the valve.

The letter A designates the engine-stand; B, the crank-shaft; C, the cylinder mounted on the stand A; D, the piston; D', the piston-rod; D<sup>2</sup>, the cross head, and E the rod connecting the piston-rod with the crank shaft.

The steam-chest F attached to the cylinder has a cover, *a*, provided with a stuffing-box, *a'*, and a steam-supply port, *b*, at one side. The disk-valve G is circular in shape and is centrally mounted on a shaft, *d*, which passes through the said stuffing box *a'* on the cover. The outer end of the shaft *d* has a crank-arm, *d'*, which may have a slot, *k*, or a wrist, *k'*. Two ports, *e e'*, lead from the steam-chest to the interior of the cylinder, one at each end. An exhaust-opening, *e'*, is central between the said two ports *e e'*, and an exhaust-port, *c*, leads therefrom to the side opposite the steam-supply port.

The valve G has an inlet-port, *f*, which opens from the outer side entirely through it. In the present instance this port is shown as a curved or segment-shaped slot, and is in a position, when the valve is properly turned, to coincide with one or the other of the ports *e*, leading to the cylinder. The area of the port *f* being less than the inlet-port of the cylinder, it controls the amount of steam entering said cylinder. The cylinder-ports being larger than the steam-ports permits a free exhaust when the valve is in proper position. On the inner face the valve has an exhaust-recess which commences at the center *g* and therefrom extends in a direction away from

the inlet-port *f* and spreads in a flaring or fan shape, *g'*, as shown. The central part, *g*, of the exhaust-recess on the valve is always coincident with the central opening, *e'*, in the cylinder, and the fan-shaped part *g'* of the exhaust-recess is in position to coincide with first one and then the other port, *e e'*. The flat surface *h* on the inner face of the valve between each end of the fan-shaped part *g'* and the inlet-port *f* serves as a cut-off. It will be seen that when the inlet-port *f* of the valve is in coincidence with one port, *e*, leading to the cylinder, steam may pass from the chest F into the cylinder at one side of the piston D, while at the same time steam exhausts from the other side through the other port, *e'*, to the recess *g g'* in the valve, and thence out at the central opening, *e'*, and exhaust-port *c*.

From the foregoing description of the valve it will be understood that it may be oscillated or rotated, and plans for both movements are shown in the drawings.

To effect the oscillation of the valve, I provide a lever, H, and attach it to a pivot, *i*, at a point somewhere near its center. The upper end of said lever has a lateral pin, *k*, which takes into the slot *k* in the crank-arm *d'*. The lower end of the said lever has a longitudinal slot, *l*, and the connecting-rod E of the engine has a stud, *m*, the end of which fits loosely in the said slot in the lever. By this construction and combination of parts the motion of the connecting-rod E will impart a vibrating movement to the lever H, which, acting on the crank-arm *d'*, will cause the valve G to oscillate.

From this description the operation of the invention will be understood.

Having described my invention, I claim and desire to secure by Letters Patent of the United States—

In an oscillating valve for steam-engines, the cylinder G, provided with ports *e e'*, in combination with the recess *g'* and the port *f*, the area of said port *f* being less than the inlet-port of the cylinder, substantially as and for the purpose set forth.

In testimony whereof I affix my signature in the presence of two witnesses.

JOHN D. FISKE.

Witnesses:

JNO. T. MADDUX,  
JOHN E. MORRIS.